

THE EFFECT OF KOLB'S EXPERIENTIAL LEARNING
MODEL ON SUCCESSFUL SECONDARY STUDENT
INTELLIGENCE AND STUDENT MOTIVATION

By

MARSHALL A. BAKER

Bachelor of Science in Agricultural Education and
Communication
University of Florida
Gainesville, FL
2004

Master of Science in Agricultural Education and
Communication
University of Florida
Gainesville, FL
2006

Submitted to the Faculty of the
Graduate College of the
Oklahoma State University
in partial fulfillment of
the requirements for
the Degree of
DOCTOR OF PHILOSOPHY
December, 2012.

THE EFFECT OF KOLB'S EXPERIENTIAL
LEARNING MODEL ON SUCCESSFUL SECONDARY
STUDENT INTELLIGENCE AND STUDENT
MOTIVATION

Dissertation Approved:

Dr. J. Shane Robinson

Dissertation Adviser

Dr. Kathleen D. Kelsey

Dr. Robert Terry, Jr.

Dr. Diane Montgomery

Dr. Dale R. Fuqua

Outside Committee Member

TABLE OF CONTENTS

Chapter	Page
I. INTRODUCTION.....	1
Background of the Study	2
Historical Context	2
Pressure Through Accountability	4
The Problem.....	5
Need for the Study	7
Statement of the Problem.....	8
Purpose of the Study	9
Statement of the Research Questions.....	9
Hypotheses.....	10
Definition of Terms.....	11
Limitations of the Study.....	14
Assumptions of the Study	15
Chapter Summary	16
II. REVIEW OF LITERATURE.....	17
Broad Perspectives of Experiential Learning	18
Philosophical Voices of Experiential Learning	18
Theoretical Framework.....	26
ELT Model.....	28
Development	31
Experiential Learning in Agricultural Education.....	33
Independent Variables of Interest	36
Experiential Based Instruction	37
Learning Styles	42
Direct Instruction	48
Outcome Variables.....	50
Sternberg’s Theory of Successful Intelligence	54
Successful Intelligence: Theory to Praxis.....	55
Teaching Analytically.....	58
Teaching Practically.....	59
Teaching Creatively	60
Student Motivation.....	61
Empirical Support for the Theory of Successful Intelligence.....	65

Effects of an Experiential Approach to Learning	67
Chapter Summary	72
III. METHODOLOGY	73
Research Design.....	74
Population	78
Description of Participants.....	79
Procedures.....	81
Approach to Analyzing the Effect of Learning Styles.....	81
Sampling Procedure	83
Development of the Treatment and Comparison Instruction.....	83
Professional Development and Assignment of Instructors.....	84
Delivery of Treatment and Comparison Instruction	85
Deferred Analytical Post-Test.....	88
Instrumentation and Data Collection	88
Kolb’s Learning Style Inventory 3.1	89
Analytical Wind Energy Assessment.....	90
Practical Assessment.....	92
Creative Assessment	92
Instructional Materials Motivation Survey	94
Fidelity of Treatment	95
Analysis of Data.....	95
Methods for Determining Effect Size.....	98
Controlling Threats to Valid Inference Making.....	98
Statistical Conclusion Validity	99
Threats to Internal, External, and Construct Validity.....	100
Summary	101

Chapter	Page
IV. FINDINGS.....	103
Findings.....	105
Correlation of Variables.....	105
Significant Differences in Analytical Skills Prior to Treatment.....	106
Means and Standard Deviations for Treatment and Control Groups.....	107
Findings Associated with Research Question One.....	114
Findings Associated with Research Question Two.....	115
Findings Associated with Research Question Three.....	118
Summary.....	121
V. SUMMARY, CONCLUSIONS, RECOMMENDATIONS, IMPLICATIONS, AND DISCUSSION.....	122
Methods.....	124
Summary of Findings.....	126
Research Question One.....	126
Research Question Two.....	127
Research Questions Three.....	128
Conclusions.....	129
Discussion and Implications.....	130
Conclusion 1.....	131
Conclusion 2.....	133
Conclusion 3.....	135
Conclusion 4.....	137
Conclusion 5.....	139
Conclusion 6.....	140
Recommendations for Praxis.....	142
Recommendations for Research.....	144
Concluding Remarks.....	146
REFERENCES.....	147
APPENDICES.....	173
APPENDIX A: Institutional Review Board Approval Form.....	174
APPENDIX B: Stillwater Public Schools IRB Approval Form.....	176
APPENDIX C: School District Research Information Sheet.....	180
APPENDIX D: Teacher Recruitment Script.....	183
APPENDIX E: Parent/Guardian Permission Form.....	185

Chapter	Page
APPENDIX F: Student Assent Form.....	186
APPENDIX G: Teaching Assistant Recruitment Flyer	190
APPENDIX H: Analytical Pretest Instrument.....	192
APPENDIX I: Analytical Posttest Instrument.....	202
APPENDIX J: Analytical Deferred Posttest.....	212
APPENDIX K: Kolb’s Learning Style Inventory (KLSI)	222
APPENDIX L: Instructional Materials Motivation Survey (IMMS)	224
APPENDIX M: Wind Turbine Design Plan	227
APPENDIX N: Creativity Scoring Guide.....	229
APPENDIX O: Educational Objectives for Wind Energy Unit	232
APPENDIX P: Experiential Learning Instructional Materials	235
APPENDIX Q: Direct Instruction Instructional Materials	257

LIST OF TABLES

Table	Page
1. KLSI 3.1 Description of the Four Phases of the Experiential Learning Process	44
2. Gender by Treatment Group	79
3. School Grade by Treatment Group	79
4. School Race by Treatment Group.....	80
5. Years in Agricultural Education Grade by Treatment Group	80
6. Brief Overview of Instructional Plan for Two Conditions of Instruction.....	87
7. Example of Creativity Tabulation and Scoring for Blade Number	94
8. Summary of p-values for Leven’s Test of Each ANOVA Analysis	97
9. Correlations between Creative, Practical, Analytical, Motivation, and Retention Measures.....	106
10. Comparison of Pre-Test Analytical Scores: An ANOVA Summary Table.....	107
11. Creative Score Means and Standard Deviations	108
12. Practical Score Means and Standard Deviations	109
13. Analytical Pre-Test Means and Standard Deviations	110
14. Analytical Post-Test Score Means and Standard Deviations.....	111
15. Analytical Deferred Post-Test Score Means and Standard Deviations	112
16. Motivation Score Means and Standard Deviations.....	113

Table	Page
17. Two MANOVA Analyses Testing for Both Simple Main and Main Effects of the Treatment Conditions by Learning Style (df = 73).....	114
18. Univariate Analysis of Variance and Discriminant Analysis, Including Creative, Practical, Analytical, and Motivation Measures	116
19. MANOVA Analyses Testing for Both Simple Main and Main Effects of the Deferred Analytical Repeated Measures (df = 60)	118
20. Comparative Analysis of Student Analytical Knowledge by Treatment Group: A Split-Plot Factorial 2.3 Repeated Measures ANOVA Summary Table (n = 63).....	119
21. Repeated Measure Analytical Repeated Design Within-Subjects Contrasts...	120
22. Means and Standard Deviations for Each Experimental Condition	127

LIST OF FIGURES

Figure	Page
1. Dewey’s Model of Experiential Learning as Conceptualized by Kolb (1984)....	20
2. The Five-Stage Experiential Learning Model (Joplin, 1981)	22
3. Dale’s (1946) The Cone of Experience	24
4. Robert’s (2006) Model of Experiential Learning Contexts	25
5. Kolb’s (1984) Model of Experiential Learning Process	29
6. Kolb’s (1984) Experiential Learning Theory of Growth and Development.....	32
7. Baker et al. (2012) Experiential Agricultural Education Model.....	34
8. Baker et al. (2012) Agricultural Education Growth and Development Model....	36
9. Fink’s (1984) Taxonomy of Significant Learning	41
10. KLSI 3.1 Model of Experiential Learning Process.....	45
11. The Nine Regions of the Experiential Learning Theory Learning Space.....	47
12. Robert’s and Ball’s (2009) Conceptual Model for Agricultural Subject Matter as a Content and Context for Teaching.....	52
13. Keller’s (1987) Motivational Categories of the ARCS Model	64
14. Random Assignment of Participants Into Two CRF-22 Designs	77
15. Visual Representation of Learning Style Interpretation and Sample Sizes for Each Distinction Achieved in the Study	82
16. Graph of Repeated Measure Analytical Scores	120

CHAPTER I

INTRODUCTION

The American education system is struggling to meet the demands of both college and career expectations (Cavanagh, 2004). Though efforts to increase science, technology, engineering and mathematics (STEM) competencies through high-stakes accountability have been noble, they seem to have been ineffective (National Center for Educational Statistics, 2011). Van Driel, Beijaard, and Verloop (2001) suggested that the rigid presentation of facts presented in a way lacking relevance could be to blame. In agricultural education, the National Research Council (1988) called the profession to join the efforts in increasing STEM education through a hands-on approach – a method familiar to agricultural educators (Roberts, 2006). This experiential approach to learning, that encompasses all elements of the agricultural education program (Baker, Robinson, & Kolb, 2012), stands as secondary agricultural educators’ answer to the call for STEM accountability. Unfortunately, however, there is little evidence to support the claim that this pedagogical approach is a sound one. In fact, some would say it absolutely is not (Kirschner, Sweller, & Clark, 2006).

Background of the Study

“Modern educators have come to realize that the only avenue of approach to the child’s mind is through the light of his experience” (Burton, 1915, p. 7). This sentiment, shared almost one century ago by Burton, in a text titled *Shop Projects Based on Community Problems*, is indicative of vocational and agricultural education both past and present. As such, experiential learning has remained a constant phrase, philosophy, and theory subscribed to by secondary agricultural educators (Baker et al., 2012; Cheek, Arrington, Carter, & Randall, 1994; Hughes & Barrick, 1993; Knobloch, 2003; McLean & Camp, 2000; Roberts, 2006). There is a rich history and tradition associated with experiential learning when viewed through the lens of agricultural education.

Historical Context

Though some would argue that vocational education over the past 100 years was predominantly behavioral (Doolittle & Camp, 1999), both Snedden and Dewey spoke strongly of the power of experiences in the actual context of various vocations, the power of expertise in a skill or trade, and the importance for repeated practice and experimentation. Snedden praised Stimson’s experiential approach to learning and shared that, “this [home project] idea is at the present time one of the features of the national program for vocational education as sponsored by the Federal Board” (Heald, 1929, p. 14). Snedden viewed experiential learning as a pedagogy that supported the ideals of social efficiency, as evident in his suggestion that, “If you want to train a youth to be an efficient plumber, you must select the actual experiences that he should have and see he gets these in a real, instead of a pseudo way” (Wirth, 1980, p. 164). In contrast, Dewey (1938) believed that instead of

asking what schools can do for industry, it should be asked what industry should do with the school (Wirth, 1971). Dewey (1938) made his belief in experiential learning clear in sharing that “amid all uncertainties, there is one permanent frame of reference: namely the organic connection between education and personal experience” (p. 25). Though these individuals held very different beliefs in the product and purpose of experiential learning, they both recognized the benefits of learning that is rooted in relevant experience. This commonality, though never stated explicitly, was a key element in the consistent presence of experiential learning in vocational and/or agricultural education. Ironically, this same philosophical divide exists today, as agricultural education seeks to identify exactly what it means to be experiential (Roberts, 2006).

Experiential learning, and especially how it is operationalized in agricultural education, has experienced great variation over the past 100 years. This change came as a result of the Vocational Education Amendments of 1963 and 1968, which broadened the scope of agricultural education but retained the experiential component (Barrick & Estep, 2011). The purpose of agricultural education continued to change, as agriculture and education experienced a great deal of change. Agricultural education was no longer in the sole business of training farmers (Camp, Clarke, & Fallon, 2000). In response to these changes, the National Research Council (1988) published a report titled, *Understanding Agriculture: New Directions for Education*, which called for hands-on experiences that focused on deepening students’ understanding of science. This concentration on achievement was furthered by the passage of the Elementary and Secondary Education Act of 2001 (most often called the No Child Left Behind Act). Young (2006) asserted that, “In a climate of increasing pressure to achieve, coupled with competition for scarce resources, it is

imperative that every content area be seen as contributing to the common goal of producing students who are ready to succeed in the 21st century” (p. 14). Following the reauthorization of Perkins legislation in 1998, strong accountability measures were implemented forcing agricultural education to contribute to the overall academic success of the students served, thus complicating the role of experiential learning in agricultural education. Leaders were forced to ask if the motto, “doing to learn, learning to do, earning to live, and living to serve” (National FFA Organization, 2008), remained sufficient in a changing climate.

Pressure Through Accountability

Education in America has found itself under a great deal of pressure to perform academically. This comes from a barrage of accusations that students are simply not prepared for college and/or careers. In an executive report prepared by the President’s Council of Advisors on Science and Technology (2010), the author shared that in the 21st century the need has never been greater for a world-class STEM workforce, but noted that the United States now lags behind other nations in STEM education at the elementary and secondary levels. Van Driel et al. (2001) asserted that delivering academic content as a rigid body of facts, theories, and rules to be memorized and practiced could be a major reason for the lack of science achievement. In addition, this type of exposure to academic content leads to a poor understanding of science concepts, and does not prepare future citizens to understand science in a rapidly evolving society. This concern is not isolated to this one document, as a multitude of sources have warned that students are ill prepared for both college and careers (e.g. Ferguson, 2004; National Center for Educational Statistics, 2011). Cynthia Schmeiser (as cited in Cavanagh, 2004), Vice President for Development of ACT, shared that, “The fact is, American high school students are not ready for college, and they’re

not ready for work. This message is not getting out” (p. 5). A consistent call for the transformation of teaching methodologies has been made in an effort to reestablish the American education system (Secretary’s Commission on Achieving Necessary Skills, 2001; National Association of Secondary School Principals, 1996, 2004; Van Driel et al., 2001). This transformation is about reinventing and redesigning America’s P-20 education system to be more responsive and broader in meeting the challenges of the nation (Futrell, 2010).

The Problem

The *what* is clear – make a change in American education to prepare students for careers and college better. The *how*, remains a constant point of debate. Very similar to the liberal versus practical debate between Dewey and Snedden in the early 1900’s, two general instructional approaches to education arise as solutions to educational reform – direct instruction and experiential learning. Direct Instruction (DI) is known as the most longstanding and comprehensive instructional program in schools today (Begeny & Martens, 2006). DI is a skill-based instructional technique in which teachers promote sequential development of student competencies by following a scripted instructional routine and providing praise at appropriate times (Becker, 1992; Gersten, Carnine, & White, 1984; Joyce & Weil, 2000; Moore, 2007; Pearson & Gallagher, 1983; Rosenshine & Meister, 1992; Vygotsky, 1978). A breadth of research (Adams & Englemann, 1996; Bock, Stebbins, & Proper, 1977; Watkins, 1997) has provided a strong empirical foundation by which proponents of DI ground their preference.

In 1916, John Dewey provided the foundational opposition to DI and similar methods by stating, “Formal instruction, on the contrary, easily becomes remote and dead – abstract

and bookish, to use ordinary words of depreciation” (p. 8). Wurdinger (2005) shared the modern sentiment to Dewey by stating,

It is time for traditional education to change the way it views knowledge. Traditional education, which consists of compartmentalized subject matter and short class periods, relies heavily on lecture and memorization. Knowledge should not be defined as one’s ability to retain larger amounts of information or receive high scores on tests. (p. 3)

This educational goal seems to match the call made earlier by colleges and industry to produce college and career ready students. If the goal is to develop critically thinking, self-motivated, problem-solving individuals who participate actively in their communities, education must mirror the context in which students will be placed ultimately (Itin, 1999; Resnick, 1987). This more holistic approach aligns more closely to a constructivist epistemology (Beard & Wilson, 2006; Dewey, 1938; Kolb, 1984), and includes methods such as inquiry-based learning, project based learning, discovery learning, case-study approach, place-based education, and the method of interest in this study – experiential learning.

Eyler (2009) shared that experiential learning, defined often by Kolb’s (1984) Experiential Learning Theory (ELT), represents the more holistic educational structured warranted by a number of educational stakeholders. ELT is a synthesis of work from key theorists (Dewey, 1934, 1938, 1958; Freire, 1974; James, 1890; Jung, 1960, 1977; Lewin, 1951; Rogers, 1961) that is built on the foundational definition of learning as the “process by whereby knowledge is created through the transformation of experience” (Kolb, 1984, p. 38). Experiential instruction is characterized by: (a) a continuous learning process grounded in

experience, (b) a process requiring the resolution of conflicts between dialectically opposed modes of adapting to the world, (c) a holistic process of adapting to the world, (d) learning that involves transactions between the person and the environment, and (e) a process of creating knowledge (Kolb, 1984). Learning, when viewed experientially, is more focused on the process than the products, highlighting the development of meta-cognitive skills critical to lifelong learning (Baker et al., 2012). This approach to learning has shown to increase student satisfaction in the course, improve retention of information as measured on examinations, develop a deeper, more complex understanding of concepts, improve practical use of information, and develop meta-cognitive skills useful in all domains (Abdulwahed & Nagy, 2009; Eyler & Giles, 1999; Eyler & Halteman, 1981; Markus, Howard, & King, 1993; Specht & Sandlin, 1991; Steinke & Buresh, 2002).

Need for the Study

Agricultural education has also felt the pressure to prepare students for college and careers, simultaneously. Roberts and Ball (2009) made this clear in proposing a dual model of agricultural education where the agricultural industry and the school work through the three components of agricultural education to produce students who can perform academically and are prepared to enter the agricultural workforce. Agricultural education, at least in name, has adopted an experiential approach to learning to meet the goals of the program since its inception in the early 1900's (Baker et al., 2012; Knoblock, 2003; Phipps, Osborne, Dyer, & Ball, 2008; Roberts, 2006). Though a small collection of literature in agricultural education supports the use of experiential learning (Anyadoh & Barrick, 1990; Cheek, Arrington, Carter, & Randell, 1994; Cheek & McGee, 1985; Kotrilik, Parton, & Leile, 1986), it provides inadequate evidence for basing such a strong commitment to

experiential learning. Secondary agricultural education must ask, “In this age of accountability, is experiential learning an effective pedagogical method?”

Kirschner et al. (2006) would argue it is not. They support strongly the practice of DI as a guided form of instruction far superior to “minimally guided” methods of which experiential learning is subsumed (p. 75). In response to the debate of DI versus experiential learning, Kirschner et al. (2006) shared that “arguments and theorizing would be important if there was a clear body of research using controlled experiments indicating that unguided or minimally guided instruction was more effective than guided instruction” (p. 79). Steinke and Buresh (2002), supporters and researchers of experiential learning, admitted that research supporting experiential learning is inconsistent and lacks breadth and depth. Moore (1999) shared that,

When it works, experiential education is a fabulous, exciting pedagogy with the power to transform individuals and institutions. But I think we need to take the risk of saying out loud that it does not always work. Our posture of true belief looks like Dorothy’s faith and the Wizard of Oz could supply the Scarecrow’s brain, the Tin Man’s heart, and the Lion’s courage; it obscures our problems and distracts us from doing something about them. (p. 23)

It is in this spirit that a renewed call exists for experiential learning research in secondary agricultural education (Baker et al., 2012; Roberts, 2006).

Statement of the Problem

The commitment to an experiential approach to learning has been a long-standing creed for agricultural education (Roberts, 2006). Experiential learning is not exclusive to

secondary agricultural education programs as it extends into teacher education programs, graduate programs in agricultural education, and the broader career and technical education sectors (Roberts, 2006). Though the role of experiential learning in agricultural education has been made clear (Baker et al., 2012), a paucity of research utilizing controlled experiments exists (Kirschner et al., 2006) to inform practitioners, at multiple levels, as they make important educational decisions regarding the effectiveness of instructional approaches for preparing students for the 21st century..

Purpose of the Study

The purpose of this study was to examine the effects of an experiential learning approach to instruction on secondary agricultural education students' successful intelligence and motivation for the course and knowledge retention. This examination compared the commonly used DI approach to experiential learning, and investigated the interaction between students' learning style and instructional approach.

The purpose of this study is congruent with that of the National Research Agenda of the American Association of Agricultural Education (Doerfert, 2011). Results of this study are valuable in addressing research priority areas four and five, as it specifically addresses: (a) a deepening of understanding of effective teaching and learning processes, (b) student motivation, (c) assessment of various learning interventions, (d) assess learning outcomes resulting from techniques inherent to agricultural education, (e) demonstrate effective STEM integration, and (f) document the outcomes of an experiential approach to learning.

Statement of the Research Questions

The study was framed by three research questions:

1. What interactions exist between students' preferred learning styles, successful intelligence, and the instructional approach chosen?
2. What statistically significant differences exist in students' successful intelligence and motivation for the course between experiential learning and direct instruction approaches?
3. Do the analytical effects achieved by experiential and direct instructional approaches persist over time?

Hypotheses

As is the convention for statistical analysis, a null hypothesis was created for each of the three research questions. Two, Completely Randomized Factorial (CRF – 22) MANOVA's were utilized to answer research questions one and two, and one Split Plot Factorial (SPF 2.3) was utilized to answer research question three. An alpha level of .05 was determined *a priori*.

Research Question One:

H₀ 1: There is no interaction between learning style, as defined by two modes of transforming information, students' successful intelligence measures, and students' motivation for the course.

H₀ 2: There is no interaction between learning style, as defined by two modes of grasping information, students' successful intelligence measures, and students' motivation for the course.

Research Question Two:

H₀ 3: There is no difference in students' successful intelligence measures and motivation for the course between the experiential learning and direct instruction approaches to learning.

Research Question Three:

H₀ 4: There is no difference in the pre-test, post-test, and deferred post-test scores for students taught with the experiential approach.

H₀ 5: There is no difference in the pre-test, post-test, and deferred post-test scores for students taught with the direct instruction approach.

Definition of Terms

Agricultural Education: “a systematic program of instruction available to students desiring to learn about the science, business, and technology of plant and animal production and/or about the environmental and natural resource systems” (Team Ag Ed, 2004, ¶ 1)

Career and Technical Education (CTE): “a planned program of courses and learning experiences that begins with exploration of career options, supports basic academic and life skills, and enables achievement of high academic standards, leadership, preparation for industry-defined work, and advanced and continuing education” (Washington Office of Superintendent of Public Instruction, Career and Technical Education section, ¶ 1, 2004).

Comparison Group: students taught using the direct instruction approach to learning.

Creativity: operationalized as original and/or divergent (Torrance, 1974).

Direct Instruction Approach to Learning: This approach, as characterized by Watkins and Slocum (2003), includes: “(a) program design that identifies concepts, rules, strategies, and ‘big ideas’ to be taught and clear communication through carefully constructed instructional programs to teach these; (b) organization of instruction, including scheduling, grouping, and ongoing progress monitoring to assure that each student receives appropriate and sufficient instruction; and (c) student-teacher interaction techniques that assure that each student is actively engaged with instruction and masters the objectives of each lesson” (pp. 75 – 76).

Ethnicity: a student characteristic categorized as African American, Asian American, American Indian, Hispanic/Latino, White, and other.

Experiential Approach to Learning: This approach is based on Kolb’s (1984) Experiential Learning Theory, which defines learning as the process whereby knowledge is created through the transformation of experience. This occurs through a cyclical process that begins with a concrete experience, includes guided student reflection, theory development resulting from that reflection called abstract conceptualization, and finally an opportunity for academic play, referred to as active experimentation. The teacher is required to play four main roles during instruction: facilitator, expert, evaluator, and coach. Six characteristics define learning and are planned purposefully for in the experiential approach to learning. The characteristics of experiential learning are: (a) learning is conceived best as a process, not in terms of outcomes; (b) learning is a continual process grounded in experience; (c) the process of learning

requires the resolution of conflicts between dialectically opposed modes of adaption to the world; (d) learning is a holistic process of adaptation to the world; (e) learning involves transactions between the person and the environment; (f) learning is the process of creating knowledge. (Kolb, 1984)

Sex: a student characteristic operationalized as male or female.

Grade Level: a student characteristic operationalized as the self-reported grade level in high school including 9th, 10th, 11th, and 12th grades.

Learning Style: a dynamic learning preference held by all learners as measured by the Kolb Learning Style Inventory (KLSI; Kolb, 1999). Styles include diverging, assimilating, converging, and accommodating, and are related directly to individual preferences in each of the four modes of thinking, as presented by Kolb's (1984) ELT.

Motivation: a product of successful intelligence (Sternberg & Grigorenko, 2004) defined as "that which accounts for the arousal, direction, and sustenance of behavior" (Keller, 1979, p. 27). Motivation, as defined by Keller (1979), includes four requirements that must be met in order for people to be motivated – attention, relevance, confidence, and satisfaction (ARCS; Keller, 1984).

Retention: student performance on a criterion – referenced examination six weeks after delivery of the curriculum.

Successful Intelligence: a broader perspective of intelligence, as purported in Sternberg's (1999a) Theory of Successful Intelligence, which is based upon four elements: (a) "intelligence is defined in terms of the ability to achieve success in life in terms of

one's own personal standards, within one's sociocultural context" (p. 296); (b) "one's ability to achieve success depends on one's capitalizing on one's strengths and correcting or compensating for one's weaknesses" (p. 297); (c) "success is attained through a balance of analytical, creative, and practical abilities" (p. 297); (d) "balancing of abilities is achieved to adapt to, shape, and select environments" (p. 298).

Treatment Group: students taught using the experiential learning approach.

Limitations of the Study

Due to the nature of behavioral research, and in compliance with ethical expectations of the Internal Review Board (IRB), a number of limitations impact the generalizability of the study. First, because this completely randomized factorial experimental design was unable to employ random sampling, results of the study are generalizable only to those students enrolled in the participating agricultural education department. Further, the fact that only a portion of the students participated in the study as a result of a lack of parental consent restrict the full range of those involved, which could insert variance not related solely to the treatments.

Second, though the clinical nature of the experiment reduced nuisance variables, it also was performed in a setting not exactly matched to the standard classroom experienced daily by the population of interest. Both DI and experiential learning were instructional strategies grounded in the environment in which they were taught, and as such, there could be issues with generalizability to the standard classroom.

Third, the utilization of two instructors to deliver both treatments could have introduced a nuisance variable related to teacher effect. As explained by Weiss (2010), it is difficult to strip the inherent differences inserted by multiple instructors and “it is necessary to consider the implications, value, and limitations of the claims that can be made” (p. 400). Every effort was made to reduce exposure to multiple teachers, but the possibility does exist that systematic differences could be attributable to teacher effect.

Fourth, the duration of the study stands as a limitation. In the spirit of controlled experimental design, the study employed a one-day treatment that included a full unit of instruction on wind turbine blade design in a short period of time. Though this technique reduces potential nuisance interactions, it also could have reduced the potency of the treatments.

Finally, it is important to note that the deferred post-test was administered six weeks after the initial experiment. This was not conducted within the clinical setting of the experiment, but was completed in a standard classroom during the regular school day. This was done to disrupt the normal educational process as little as possible. It is recognized that a number of nuisance variables could have played a role in this measure.

Assumptions of the Study

The following assumptions were made in the planning, conducting, and analysis of the study.

1. Participants in the study approached the treatments and instruments with sincerity, and performed to the best of their ability in this setting.

2. Substantial instruction in wind energy was not delivered between the delivery of the treatment and the deferred post-test.
3. Students' creative, practical, and analytical skills, as well as motivation for the content, can be measured through the instrumentation employed in this study.

Chapter Summary

This chapter provided the background for research related to experiential learning in response to a call for education that seeks to prepare secondary students better for college and careers. The need for the study was discussed, which led to three research questions:

1. What interactions exist between students' preferred learning styles, successful intelligence, and instructional approach chosen?
2. What statistically significant differences exist in students' successful intelligence and motivation for the course between experiential learning and direct instruction approaches?
3. Do the analytical effects achieved by experiential and direct instructional approaches persist over time?

Five null hypotheses logically followed for utilization in the statistical analyses. The chapter included definitions of key terms, making specific the operationalization of concepts relevant to the study.

Chapter 2 will expand on the literature presented in this chapter, and will feature the conceptual and theoretical frames of the study. Literature related to experiential learning, direct instruction, successful intelligence, and motivation will be discussed.

CHAPTER II

REVIEW OF LITERATURE

This study used a completely randomized factorial (CRF 2.2), and a split-plot factorial (SPF 2.3) experimental design to determine the effects of utilizing instruction based on Kolb's (1984) Experiential Learning Theory (ELT) on secondary agricultural education students' successful intelligence (Sternberg, 1999a) and motivation for learning course content. The study utilized students enrolled in a secondary agricultural education program in Oklahoma. The treatment group received instruction designed around Kolb's (1984) experiential model of learning, which included purposeful planning of a concrete experience, guided reflection on that experience, abstract conceptualization resulting in theory development, and opportunities for academic play, where students transformed the experience actively. The study compared the experiential learning approach to that of the commonly used method of direct instruction (DI). Chapter I included a brief background of the study, the need for the study, the problem statement, purpose, research questions, definitions, significance of the findings of the study, limitations, and assumptions. Chapter II provides an in-depth review of the literature related to key variables of the study. The chapter is divided into sections including broad perspectives of experiential

learning, theoretical framework, independent variables of interest, outcome variables, effects of an experiential approach to learning, and a chapter summary.

Broad Perspectives of Experiential Learning

Experiential learning is one of the most fundamental and intuitive forms of educational theory (Beard & Wilson, 2006). A “fabulous haze” exists regarding what the term experiential learning means exactly; however, the general nature of experiential learning is understood and agreed upon fairly well (Roberts, 2012, p. 8). Stehno, in 1986, reviewed seven models of experiential learning and concluded that each included four basic processes: (a) action that creates an experience, (b) reflection on the action and experience, (c) abstractions drawn from the reflection, and (d) application of the abstraction to a new experience or action. Some have called experiential learning an ill-conceived, passing, educational fad (Kirschner et al., 2006). However, a review of the historical underpinnings, and subsequent evolution and development, of experiential learning demonstrates the foundation of this philosophy of education. The following sections will review important historical perspectives of experiential learning, present the philosophy of experiential education, and feature models of experiential learning that are discussed in the literature commonly. This section will conclude with the role experiential learning has played in agricultural education. Kolb’s (1984) model is excluded from this section and will be presented in a subsequent theoretical framework section.

Philosophical Voices of Experiential Education

John Dewey (1916; 1938) is known as the father of experiential education. His desire for educational reform was in the context of the great liberal versus practical education debate, where a strong push for social efficiency was present. In *Democracy and Education*, Dewey (1916) posited that the aim was an efficient democracy accomplished through positive use of native individual capacities in occupations having social meaning. Dewey (1938) believed in the education of the whole child, and that it is achieved best in the light of a person's experience. There was a link made between doing and understanding that formed the basis of experiential learning as known today (Itin, 1999). Dewey (1938) stated that the current educational system should not be discarded ignorantly, but reformed. "The trouble is not the absence of experiences, but their defective and wrong character" (Dewey, 1938, p. 27). It was made evident in all of Dewey's (e.g., 1916, 1938) work, which emphasized that education through experience is not "wholly in the air" (1938, p. 28), but that it required careful and purposeful planning, guiding, and evaluation by the instructor.

More specific to the development of models and theories of experiential learning, a visual representation of Dewey's (1938) Model of Experiential Learning (see Figure 1) depicts the key idea that learning is a dialectic process integrating experiences and concepts, observations, and action. It is the impulse of experience that gives ideas their moving force, and the postponement of immediate action allows time for observation and judgment. It is through this dual process of impulse and judgment that sophisticated, well-developed concepts are internalized.

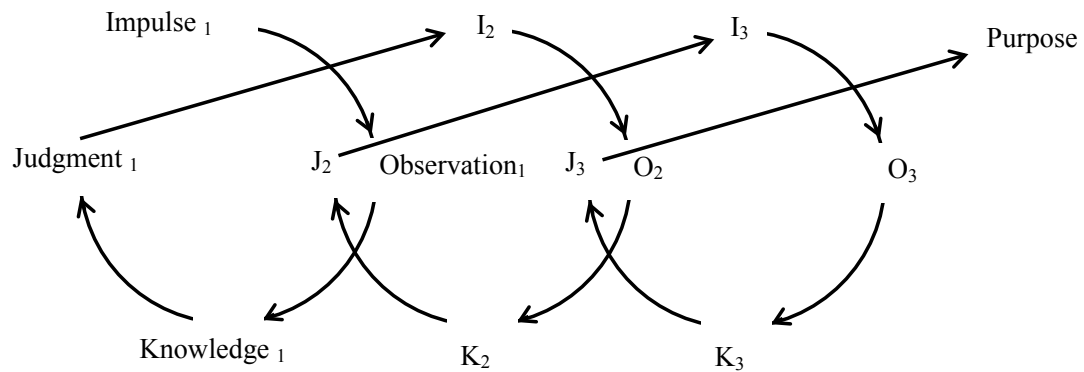

Figure 1. Dewey's Model of Experiential Learning as Conceptualized by Kolb (1984). Reprinted from *Experiential Learning: Experience as the Source of Learning and Development* (p. 42), by David A. Kolb, 1984, Englewood Cliffs, NJ: Prentice-Hall, Inc. Copyright 1984 by Prentice-Hall, Inc. Reprinted with permission.

Similar to Dewey, Kurt Lewin (1951) felt that education was grounded best in an individual's personal experience. Grounded in experience with action research and laboratory training, learning, change, and growth are achieved best through direct experiences, followed by the collection of data and observations about that experience (Kolb, 1984). Information deduced from those data are then utilized in subsequent experiences where *theories* are developed and refined. Lewin (1951) concluded that these experiences serve as the platform by which learners validate and test abstract concepts, and also emphasize the importance of feedback processes. It was Lewin's (1951) belief that much of the ineffectiveness in various settings was due to poor feedback processes.

Piaget (1969; 1971) expanded further on this dualistic nature of learning by adding the ideas of accommodation and assimilation of experiences. Piaget (1971) explained that the key to learning lies in the mutual interaction of the process of

accommodation of concepts, or schemas, to experiences in an individual's environment and the process of assimilation of events and experiences into existing concepts and schemas. Piaget (1971) also described the process of cognitive development, whereby from birth to age 14 to 16, an individual moves through sensory-motor, representational, concrete, and formal operations stages. In respective order and coordinating with the stages, a learner is involved in enactive, ikonic, inductive, and hypothetico-deductive learning.

Experiential learning is conceived best as a process and not merely a product (Kolb, 1984). Jerome Bruner (1966) and Paulo Freire (1974) shared in this belief and explained that learning is not merely the banking of facts. The purpose of education is to stimulate inquiry and skill in the process of learning – not to memorize inert pieces of information only. Freire (1974) opposed the idea of education becoming “an act of depositing, in which the students are the depositories and the teacher is the depositor” (p. 58), and felt that “apart from inquiry, apart from the praxis, men cannot be truly human” (p. 58). The meta-cognitive process of learning is more valuable than the information itself, for that is where learners are empowered to transform their own experiences (Dewey, 1938; Kolb, 1984).

Though these philosophical pillars are critical in understanding experiential learning, Joplin (1981) saw the need to “move from a vague notion of experiential education to a more structured one,” and she proposed “a five stage model with nine defining characteristics to further clarify what is meant by experiential education” (p. 17). Inherent in the model (see Figure 2) is the concept that all learning is experiential and can occur from varying *maxi* and *mini* scopes as.

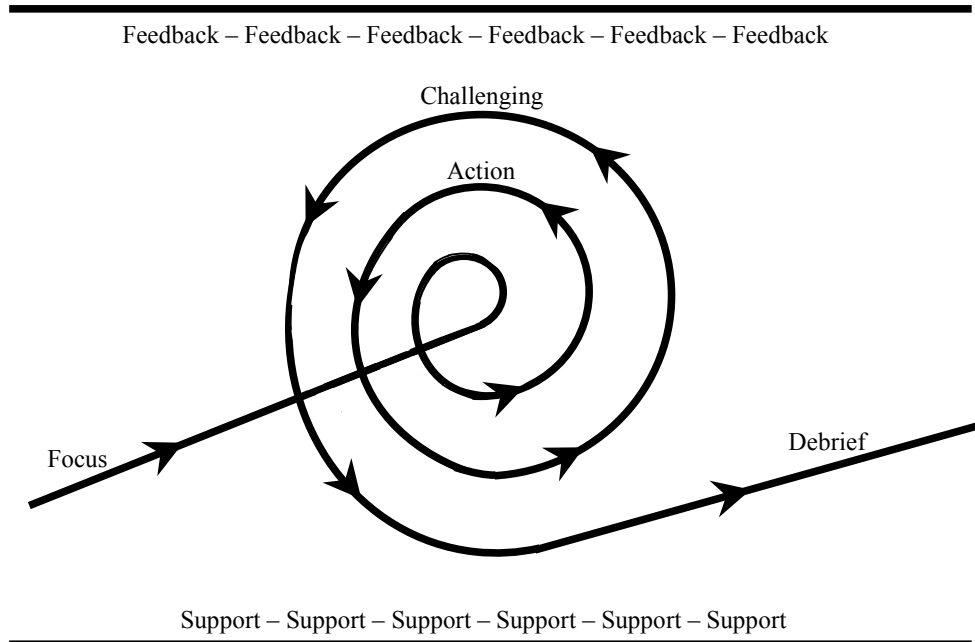

Maxi	whole school design one course design a project in the course one day of the course a conversation
Mini	a flash of insight

Figure 2. The Five-Stage Experiential Learning Model (Joplin, 1981). Adapted from “On Defining Experiential Education,” by Laura Joplin, 1981, *The Journal of Experiential Education*, 4(1), p. 17.

Thus, all learning, regardless of the scope, involves the five stages noted in the model: (a) focus, (b) action, (c) support, (d) feedback, and (e) debrief. Focus includes presenting the task and isolating the learner’s attention for concentration. Action is represented by the

“hurricane” (Joplin, 1981, p. 18) and places the learner in an unfamiliar situation requiring the use of new knowledge or skills. Support and Feedback occur throughout the process ensuring that the student will remain motivated to complete the task and receive important information related to the task. Finally, debriefing allows for learning to be recognized, articulated, and evaluated (Joplin, 1981). According to Joplin (1981), experiential learning is: (a) student based rather than teacher based, (b) personal not impersonal in nature, (c) process and product oriented, (d) evaluated for both internal and external reasons, (e) holistic in nature, (f) organized around experience, (g) perception based rather than theory based, and (h) individual based rather than group based.

Dale (1946) furthered Joplin’s desire to move experiential learning from theory to praxis by constructing ten levels of experiences ranging from concrete to abstract (see Figure 3). The base of the cone is indicative of more concrete experiences, such as purposeful experiences, contrived experiences, and dramatic participation. The top of the cone represents the most abstract experiences, including verbal and visual symbols. Each level of the cone represents general movement along the abstract/concrete continuum. A key difference for the learner in these experiences is the actual exposure to the experience. At the base, students are in direct contact with the experience; in the middle students interact through observation; at the top, students must rely completely on abstract conceptualizations of the experience (Dale, 1946). This distinction verified the idea that all learning can occur through experiences located throughout the cone.

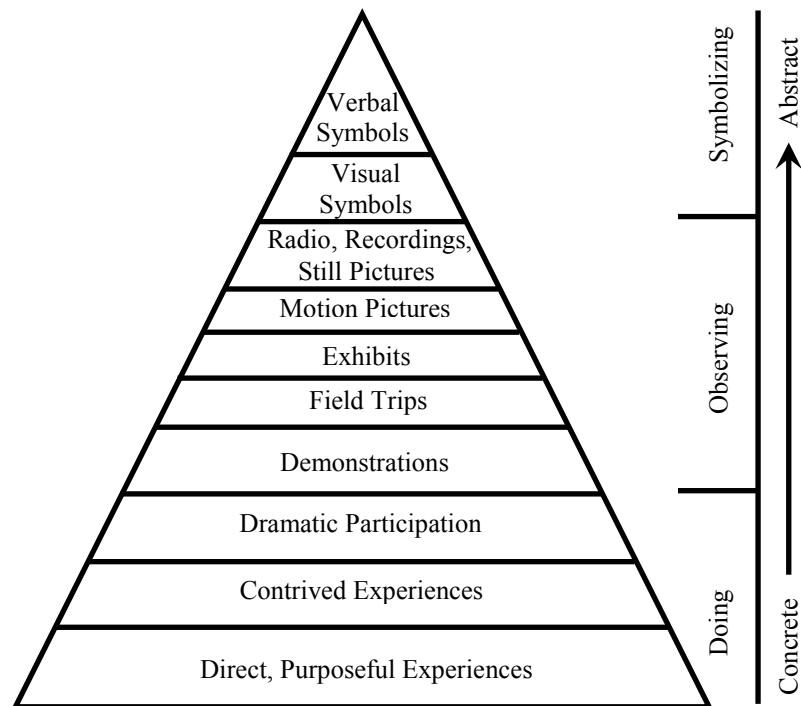

Figure 3. Dale's (1946) The Cone of Experience. Adapted from *Audio-visual methods in teaching* (p. 42), by E. Dale, 1946, New York, NY: The Dryden Press.

The idea that all learning is experiential (Kolb, 1984) has at times caused ambiguity and confusion over what is, and is not, experiential learning (Roberts, 2006). Building on Dale's (1946) Cone of Experience, Roberts (2006) clarified this point and developed a Model of Experiential Learning Contexts (see Figure 4). Roberts (2006) shared the importance of being more specific in naming the context of various learning experiences to reduce ambiguity in the study and discussion of experiential learning. Four dimensions can define experiences: the level, duration, intended outcome, and setting. This model is a synthesis of four works. The level is rooted in Dale's (1946) Cone of Experience, the duration from Joplin's (1981) concept of *maxi* to *mini* duration,

the intended outcome from Steinkaker's and Bell's (1979) taxonomy of learning, and the setting from Etling's (1993) formal to non-formal educational settings distinction.

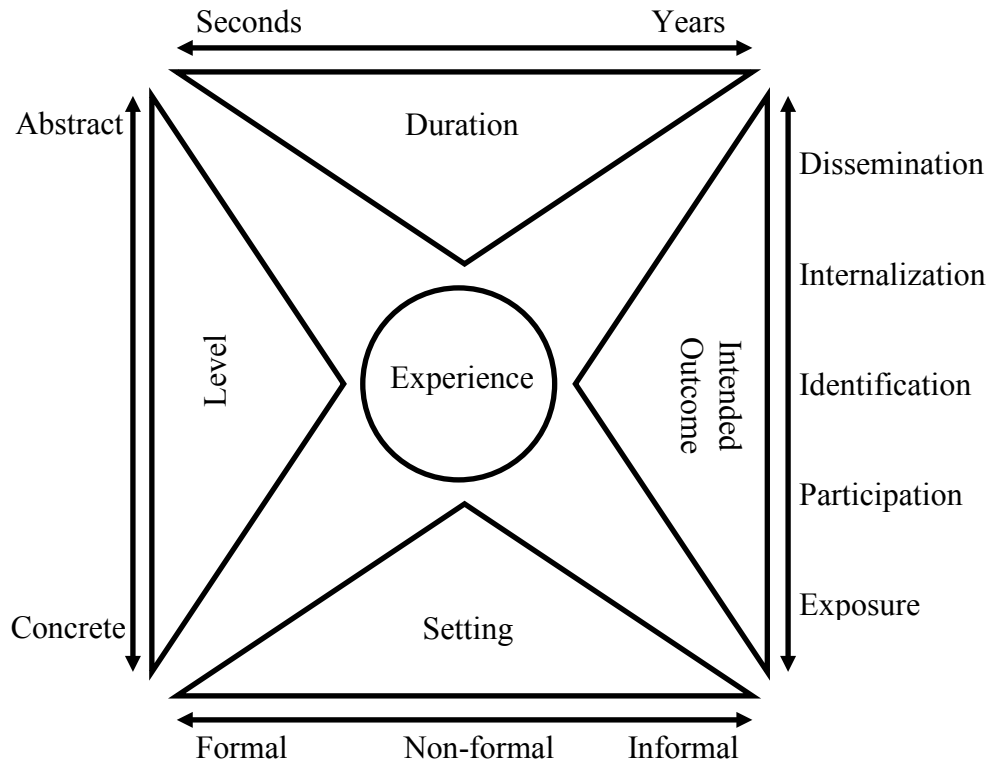

Figure 4. Robert's (2006) Model of Experiential Learning Contexts. Reprinted from "A Philosophical Examination of Experiential Learning Theory for Agricultural Educators," by T. Grady Roberts, 2006, *The Journal of Agricultural Education*, 47(1), p. 26.

Itin (1999) supported a broad philosophy of experiential education built on the foundational work of key theorists (Bruner, 1966; Dewey, 1938; Freire, 1973; Lewin, 1951; Piaget, 1969) in experiential learning:

Experiential education is a holistic philosophy, where carefully chosen experiences supported by reflection, critical analysis, and synthesis, are structured

to require the learner to take initiative, make decisions, and be accountable for the results, through actively posing questions, investigating, experimenting, being curious, solving problems, assuming responsibility, being creative, constructing meaning, and integrating previously adopted knowledge. Learners are engaged intellectually, emotionally, socially, politically, spiritually, and physically in an uncertain environment where the learner may experience success, failure, adventure, and risk taking. The learning usually involves interaction between learners, learner and educator, and learner and environment. It challenges the learner to explore issues of values, relationship, diversity, inclusion, and community. The educator's primary roles include selecting suitable experiences, posing problems, setting boundaries, supporting learners, insuring physical and emotional safety, facilitating the learning process, guiding reflection, and providing the necessary information. The results of the learning form the basis of future experience and learning. (p. 93)

The most prominent theory conveying this philosophy is Kolb's (1984) Experiential Learning Theory, which will serve as the theoretical framework for this study.

Theoretical Framework

This study is based on Kolb's (1984) Experiential Learning Theory (ELT). The theory represents a holistic approach to learning built on the work of prominent scholars of the 20th century, including John Dewey (1934, 1938, 1958), Kurt Lewin (1951), Jean Piaget (1969, 1971), William James (1890, 1907), Carl Jung (1960, 1977), Paulo Freire (1973, 1974), and Carl Rogers (1961). Experiential learning, as described by Kolb's

(1984) ELT theory, offers a view of learning that is fundamentally different than that of behavioral theories of learning mainly due to the role of consciousness and subjective experience being placed at the center of learning. However, Kolb (1984) noted that:

It should be emphasized that the aim of this work is not to pose experiential learning theory as a third alternative to behavioral and cognitive learning theories, but rather to suggest through experiential learning theory a holistic integrative perspective on learning that combines experience, perception, cognition, and behavior (p. 21).

Kolb and Kolb (2005b) explained that the theory is built on six propositions derived from the work of the scholars associated with experiential learning:

- Learning is defined best as a process and not by learning outcomes. “Education must be conceived as a continuing reconstruction of experience – the process and goal of education are one and the same thing” (Dewey, 1897, p. 79).
- All learning is relearning, as described by Piaget’s (1969) two mechanisms of how an individual adopts new ideas – integration and substitution (Elkind, 1970). Ideas that are integrated become more stable elements of an individual’s conception of the world, while those that are substituted are more prone to validation.
- Learning involves the resolution of conflicts between dialectically opposed modes of adaptation to the world. Conflict gives ideas their moving force (Dewey, 1938), as a person is required to move between reflection and action and thinking and feeling, as described in the Lewinian model (Lewin, 1951).

- Learning is a holistic process of adaptation to a person's world that extends beyond simple cognition. It involves the integrated functioning of the whole person including thoughts, feelings, perceptions, and behaviors (Jung, 1923).
- Learning results from synergetic transactions between the person and his or her environment. Learning occurs best when students are asked to call on previous knowledge and experiences as they accommodate and assimilate information (Piaget, 1969, 1971).
- Learning is the process of creating knowledge. ELT is a constructivist theory of knowledge (Kolb, 1984) that stands in contrast to the transmission model that is the dominant method in today's educational setting (Kolb, 2005b). Piaget (1978), in reference to the supporting epistemology of experiential learning, shared that, "objects are known only through the subject, while the subject can know himself or herself only by acting on objects materially and mentally" (p. 651)

Kolb (1984) defined learning through ELT as "the process whereby knowledge is created through the transformation of experience. Knowledge results from the combination of grasping and transforming experience" (p. 41).

ELT Model

Kolb's (1984) ELT model (see Figure 5) depicts the learning process as including four adaptive learning modes: concrete experience (CE), reflective observation (RO), abstract conceptualization (AC), and active experimentation (AE). At the crux of the theory lies the principle that knowledge is the product of how a learner grasps and transforms experiences.

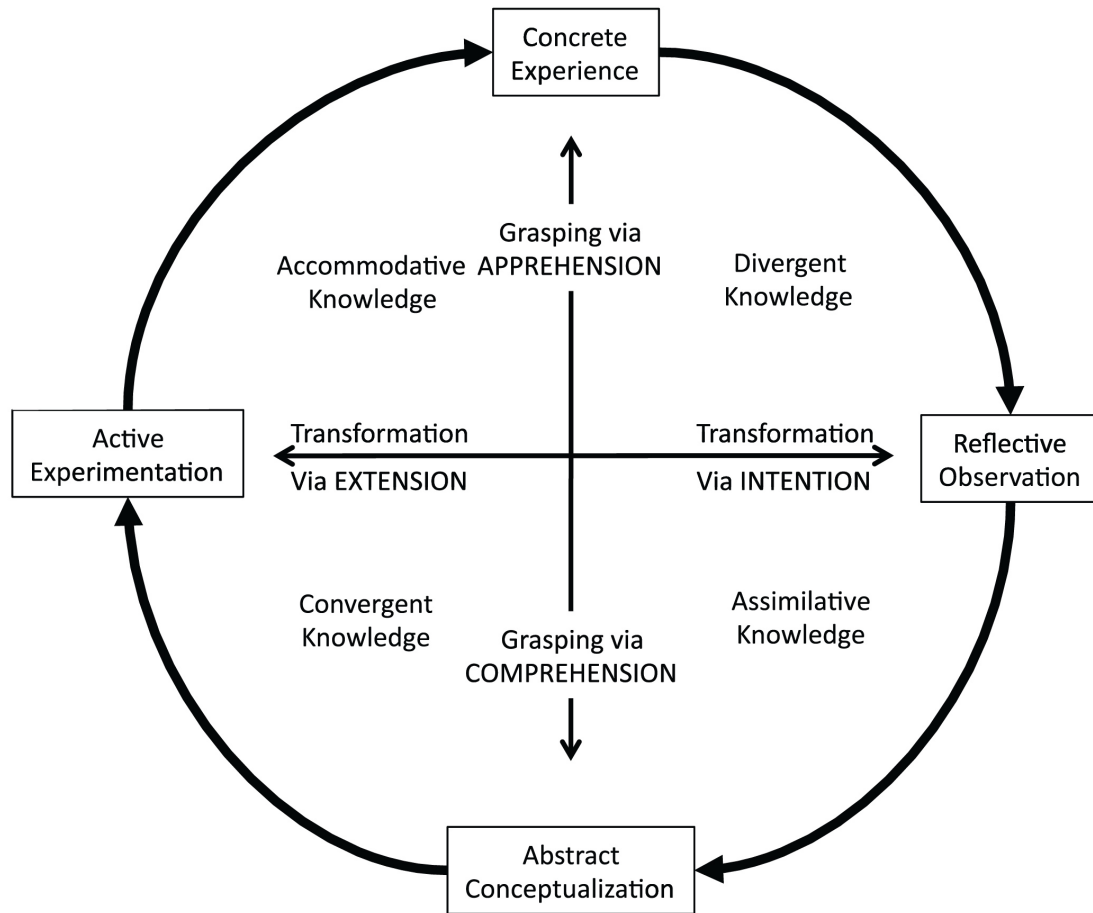

Figure 5. Kolb's (1984) Model of Experiential Learning Process. Reprinted from *Experiential Learning: Experience as the Source of Learning and Development* (p. 42), by David A. Kolb, 1984, Englewood Cliffs, NJ: Prentice-Hall, Inc. Copyright 1984 by Prentice-Hall, Inc. Reprinted with permission.

The abstract versus concrete dialectic is described as the prehension dimension and is depicted as the vertical axis in the model. There, experiences are either grasped through reliance on conceptual interpretations and symbolic representations called *comprehension* or through reliance on the tangible, sensory qualities of an immediate experience called *apprehension*. The horizontal axis is composed of the active versus reflective dialectic.

Experiences are transformed either through internal reflection called *intention* or through active external manipulation called *extension*. This process is cyclical in nature where, ideally, learners are exposed to each of the learning modes – experiencing, reflecting, thinking, and acting – in a recursive process that is dependent on the unique experiences and elements to be learned. Concrete experiences are the basis for the learners’ reflections. The reflections are assimilated into abstract concepts to be utilized in future contexts. These abstract concepts are then tested actively and serve to inform the learner when he or she is exposed to new experiences. Of critical importance is the concept that learning requires *both* a grasp of a figurative representation of experience and some transformation of that representation. The existence of a concrete experience only does not constitute experiential learning. “We start with supposition that there is only one primal stuff or material in the world, a stuff of which everything is composed we call that stuff ‘pure experience’” (James, 1912, p. 4). All elements of the ELT model are considered experiential, as any immediate experience is neither the subject nor object until acted on in context of the situation at hand.

Kolb (1984) purported four different basic forms of knowledge created from the two dialectically opposed ways of grasping and transforming an experience. Experiences that are grasped via apprehension and then transformed via intention result in *divergent* knowledge. Experiences grasped via comprehension and then transformed via intention result in *assimilative* knowledge. Experiences grasped via comprehension and then transformed via extension create *convergent* knowledge, and finally experiences grasped through extension and then transformed via apprehension result in *accommodative*

knowledge. The complexity of these four types of knowledge relates to the theory of development within experiential learning discussed later.

Development

Another important element of Kolb's (1984) ELT is the concept of human development. Learning shapes the course of human development through integrative complexity of the four modes of learning. As depicted in Figure 6, Kolb's (1984) ELT Model lies at the base of the cone of human development. Arising from each of the four learning modes is increasing behavioral complexity, symbolic complexity, affective complexity, and perceptual complexity leading to a fully integrated approach of experiences through development. Drawing from the work of Piaget (1971), the human development process is divided into three broad developmental stages: acquisition, specialization, and integration included in the model. Stage one, acquisition, extends from birth to adolescence and includes the sensorimotor, iconic, and concrete operations (Kolb, 1984). It is in this stage that learners move from the focus on immediate experience to symbolic development and the transformation of that stimulus. Stage two, specialization, marks the time beyond adolescence where specialization and the refinement of meta-cognitive skills is the dominant learning practice. During this time, the personality dynamics and external social factors serve as the impetus for stability and life path decisions. In this stage, a learner establishes a sense of individuality through the

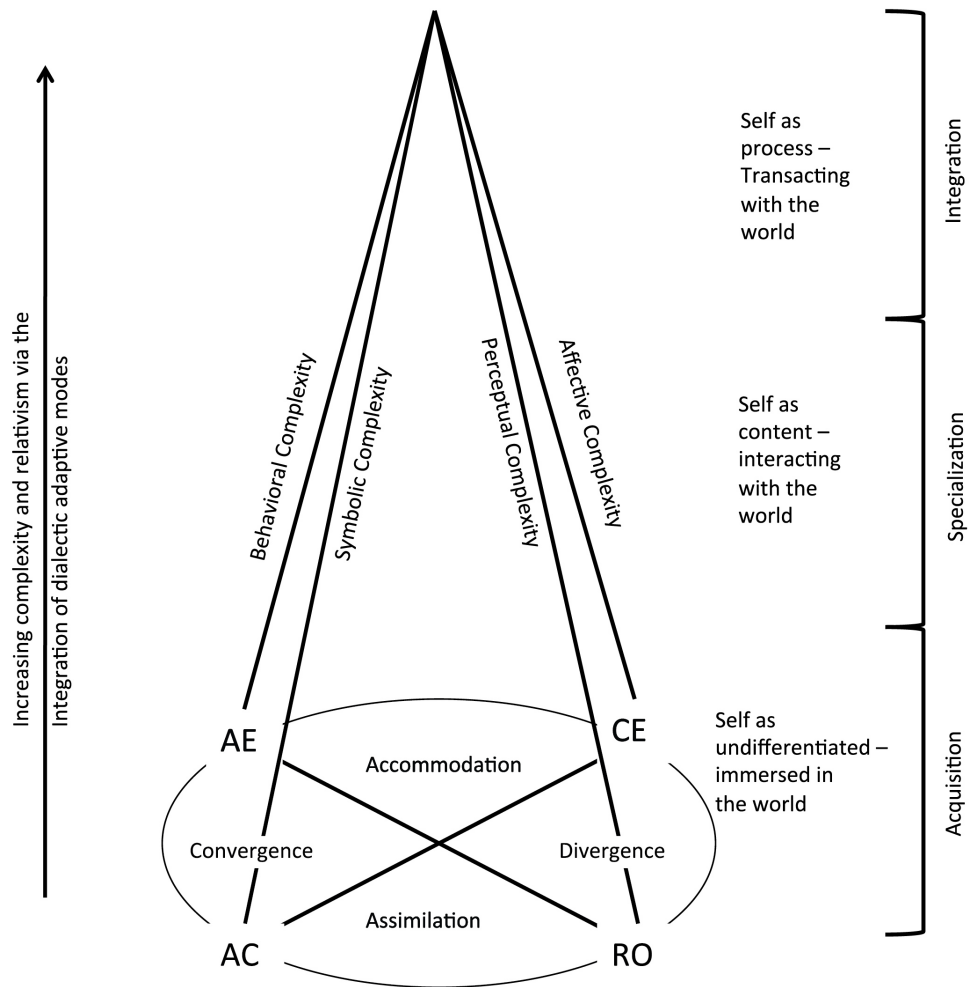

Figure 6. Kolb's (1984) Experiential Learning Theory of Growth and Development.

Reprinted from *Experiential Learning: Experience as the Source of Learning and Development* (p. 141), by David A. Kolb, 1984, Englewood Cliffs, NJ: Prentice-Hall, Inc.

Copyright 1984 by Prentice-Hall Inc. Reprinted with permission.

acquisition of an identity both as a person and a learner (Kolb, 1984). Finally, some learners reach stage three – integration. It is at this point that the stability of stage two arises from the battle of social specialization. Kolb (1984) referred to this as the stage of *awakening*, as an individual's eyes are opened beyond the preferred and specialized modes of thinking and into a more integrated approach. Kolb (1984) pointed toward

Jung's (1923) description that, "this antagonism of human qualities is the great instrument of culture" (p. 94) and represents the pinnacle of human development – seeing beyond one's self.

Experiential Learning in Agricultural Education

Experiential learning, as defined by Kolb (1984), has been a longstanding foundation of secondary agricultural education (Cheek et al., 1994; Hughes & Barrick, 1993; Knoblock, 2003; McLean & Camp, 2000; Roberts, 2006; Stewart & Birckenholz, 1991). Baker et al. (2012) shared that agricultural education is at an advantage because its curriculum lends itself so easily to using experiential learning approaches throughout all aspects of the program. Though, traditionally, educators have identified SAE programs as the primary experiential learning component of agricultural education (Benson, 1981; Warren & Flowers, 1992), Baker et al. (2012) purported that all components of agricultural education are experiential, and thus introduced the Experiential Agricultural Education Model (EAEM) (see Figure 7), which is designed around Kolb's (1984) ELT. In this model, the experiential learning process is embedded in each of the three components of agricultural education: (a) instruction, (b) SAE, and (c) National FFA Organization.

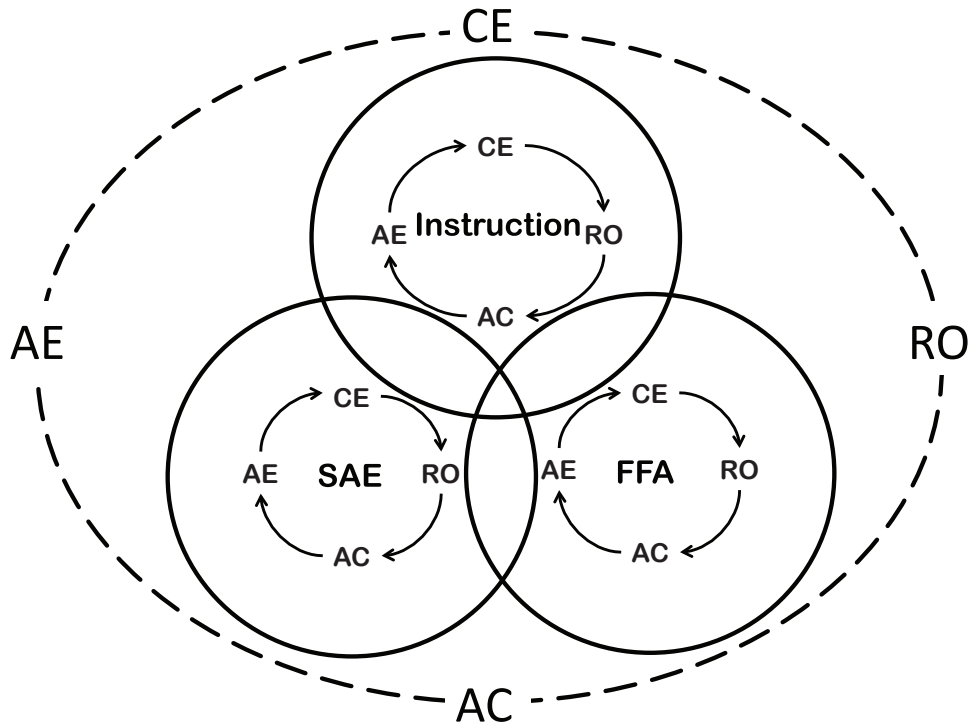

Figure 7. Baker et al. (2012) Experiential Agricultural Education Model. Reprinted from “Aligning Kolb’s Experiential Learning Theory with a Comprehensive Agricultural Education Model,” by M. A. Baker, J. S. Robinson, and D. A. Kolb, 2012, *The Journal of Agricultural Education*, 53(4), p. 9.

Each of the three components has varying contexts, as defined by Roberts (2006), but each contains the characteristics of experiential learning. For example, typically, classroom and laboratory experiences occur in a more formal educational setting and could include guest speakers, research projects, science experiments, greenhouse activities, or group projects as the impetus for the experiential learning process. SAE would be a more informal, long-term project where students drive the experience through an independent project. Examples include a student livestock project, community service efforts, or an agriscience research project. FFA activities, such as attending the National

FFA Convention, state speech contest, or running for a chapter office are also more informal, over the period of a semester or school year, and are related to specific learning goals. Each of the components includes concrete experiences (CE), the opportunity for reflective observation (RO), which leads to abstract conceptualization (AC), and finally the chance to actively experiment (AE) (see Figure 7).

Learning space is inherent in the EAEM and is depicted by the solid circles surrounding each component and the dotted line surrounding the entire model. Grounded in Brofenbrenner's (1977, 1979) work on human development, these learning spaces include a student's microsystem, which includes the daily *here and now* experiences, as well as the larger macrosystem that is constantly moving as students develop over multiple years in the agricultural education program. Following Kolb's (1984) theory of development, Baker et al. (2012) explained further that the goal of any agricultural education program is to develop the cognitive complexity of each of the learning modes through long-term participation in the full program. The Experiential Taxonomy, as developed by Steinaker and Bell (1979) and reasserted by Roberts (2006), demonstrated that the goal for each student is to move from exposure as a first-year member of agricultural education to dissemination at the completion of the program. The Agricultural Education Growth and Development Model (AEGDM) mirrors the development model of Kolb (1984) with the agricultural education program model at the base of the cone (Baker et al., 2012) (see Figure 8).

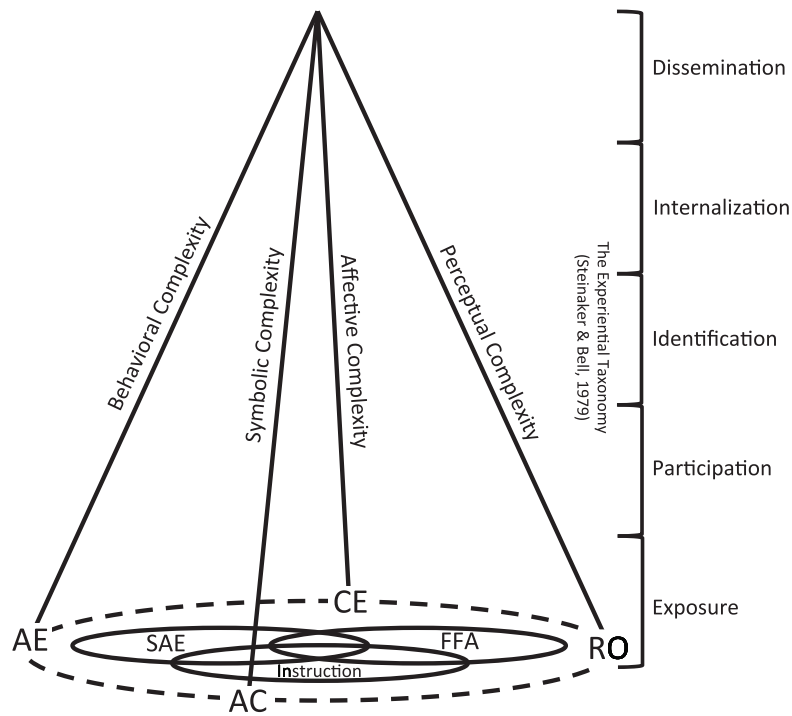

Figure 8. Baker et al. (2012) Agricultural Education Growth and Development Model. Reprinted from “Aligning Kolb’s Experiential Learning Theory with a Comprehensive Agricultural Education Model,” by M. A. Baker, J. S. Robinson, and D. A. Kolb, 2012, *The Journal of Agricultural Education*, 53(4), p. 11.

Independent Variables of Interest

Independent variables of interest in this study included the two instructional strategies: experiential based instruction and direct instruction. Another variable included in the study was students’ preferred learning style, as defined by Kolb’s (1984) ELT. The following sections of Chapter 2 will focus on literature describing these variables.

Experiential Based Instruction

There is a fabulous haze that surrounds the term experiential learning (Savage, 2010). As discussed earlier, the answer to the question, “Is experiential learning a philosophy, a method, a field, or all three?” is a somewhat complicated response of “Yes.” Roberts (2012, p. 9) put it best when he asked, “How do we hang on to the distinctive ways experiential education frames the educational process while at the same time ensur[e] that it does not become quaint and overly isolated?” It is important to make the distinction between the philosophy of experiential education and the teaching and learning method of experiential learning (Itin, 1999). Experiential learning has been utilized as a method in a number of domains like engineering (Abdulwahed & Nagy, 2009), nursing (Birch et al., 2007), wildlife (Millenbah & Millspaugh, 2003), and agricultural education (Baker et al., 2012; Roberts, 2006). “Unless experience is so conceived that the result in a plan for deciding upon subject-matter, upon methods of instruction and discipline, and upon material equipment and social organization of the school, it is wholly in the air” (Dewey, 1938, p. 28). Though an experiential approach to learning is not a scripted and outlined method of teaching, Dewey was clear in his explanation that experiential learning *has* to be a method.

So what is an experiential learning method? First, all learning involves a previous or current experience (Kolb, 1984). This method has received attention as a reaction against the highly structured, overly didactic, teacher controlled transmission of knowledge approach that occurs in numerous public schools every day (Begeny & Martens, 2006). It supports a more participative, learner-centric approach with an emphasis on direct engagement, learning experiences, and the construction of knowledge

by the learner (Andreson, Boud, & Cohen, 2000). Six characteristics define learning and are planned purposefully for in the experiential approach to learning (Kolb, 1984). These characteristics of experiential learning are: (a) learning is best conceived as a process, not in terms of outcomes; (b) learning is a continual process grounded in experience; (c) the process of learning requires the resolution of conflicts between dialectically opposed modes of adaptation to the world; (d) learning is a holistic process of adaptation to the world; (e) learning involves transactions between the person and the environment; (f) learning is the process of creating knowledge (Kolb, 1984).

Andreson et al. (2000) synthesized a number of key experiential learning theories and defined six characteristics that distinguish experiential learning from other methods:

1. Experiential learning demands that three factors are present – intellect, feelings, and senses. Learning occurs in this holistic context.
2. Personal experience is the root of the learning process. Those experiences must be recognized and acted on so that learning is integrated into the learner's values and understanding.
3. Purposeful, guided reflection must be present so students can add to, and transform, ideas and concepts into deeper understanding. Learning is the process whereby knowledge is created through the transformation of experience (Kolb, 1984).
4. The design of experiences must be intentional. Deliberately designed learning events are referred often to as structured activities and include simulations,

games, role-play, visualizations, focus group discussions, and hypothetical scenarios.

5. Learning must be facilitated. Teachers, coaches, parents, leaders and/or others must be present and play important roles as a facilitator, expert, evaluator, and coach (Kolb, 2009).
6. Learning outcomes are identified and assessed. Experiential learning is more concerned with the process than the product, and assessments should be congruent with that theme. Assessments include group projects, critical essays, reading logs, learning journals, negotiated learning contracts, peer assessment, and authentic assessments.

These six characteristics represent the means by which learning occurs experientially. The end involves learners' own appropriation of what is personally significant and meaningful (Andreson et al., 2000).

In opposition to experiential learning as a method of instruction, Kirschner et al. (2006) stated that, "the result of [experiential learning] is a series of recommendations that most educators find almost impossible to implement" (p. 76). Steinaker and Bell (1979) worked to make the connection between theory and teaching in a number of environments, including formal settings.

When [experiential learning] is keyed in a curriculum to a series of taxonomically sequenced teaching strategies and learning experiences, it can augment learner achievement. Using the experiential taxonomy, one can plan an experience with specific objectives, with a series of taxonomically ordered activities keyed to

identified teaching strategies, and with correlated elements of creativity, critical thinking, and problem solving. (Steinaker & Bell, 1979, p. xi).

The taxonomy of experiential learning, discussed by Steinaker and Bell (1979), includes five taxonomic levels: (a) exposure, (b) participation, (c) identification, (d) internalization, and (e) dissemination. Exposure is defined as the consciousness of the experience. This includes the role of the teacher in gaining attention, maintaining student confidence, and keeping the anxiety level of the associated stimuli within bounds. Participation is when the learner decides to become involved in the experience actively. The teacher must provide specific and purposeful guidance throughout this level providing the necessary structure and focus on learning goals. Identification is the point when the experience is moving toward the grasping of abstract concepts of interest to the lesson. Teachers must act as a moderator and/or prompt to facilitate the learning process. Internalization occurs when students begin to accommodate new knowledge into previous schemas so that change occurs within the individual. Teachers begin to remove their scaffolding as students begin to extend the knowledge on their own. Finally, dissemination represents the point where the information has become the learners' and they extend that in ways they choose. Teachers must provide a variety of venues by which students can express the experience (Steinaker & Bell, 1979).

Fink (2003) provided a modern day approach to experiential learning very similar to that of Steinaker and Bell (1979). In *Creating Significant Learning Experiences*, Fink (2003) conceded that learning built around the cognitive structure discussed by Bloom (1956) is important but inadequate when seeking to produce career ready graduates. New kinds of learning are required that extend beyond cognitive learning alone (Fink, 2003).

Experiential learning results in *significant learning* built on six types of instruction (see Figure 9) and indicative of the focus of instruction that exhibit principles of experiential learning. Fink's (2003) structure visually demonstrates the more holistic nature of education, as explained by both Kolb (1984) and Sternberg (1999a), and as such, includes important constructs to the study such as creativity, analytical abilities, aspect of motivation, and practical thinking.

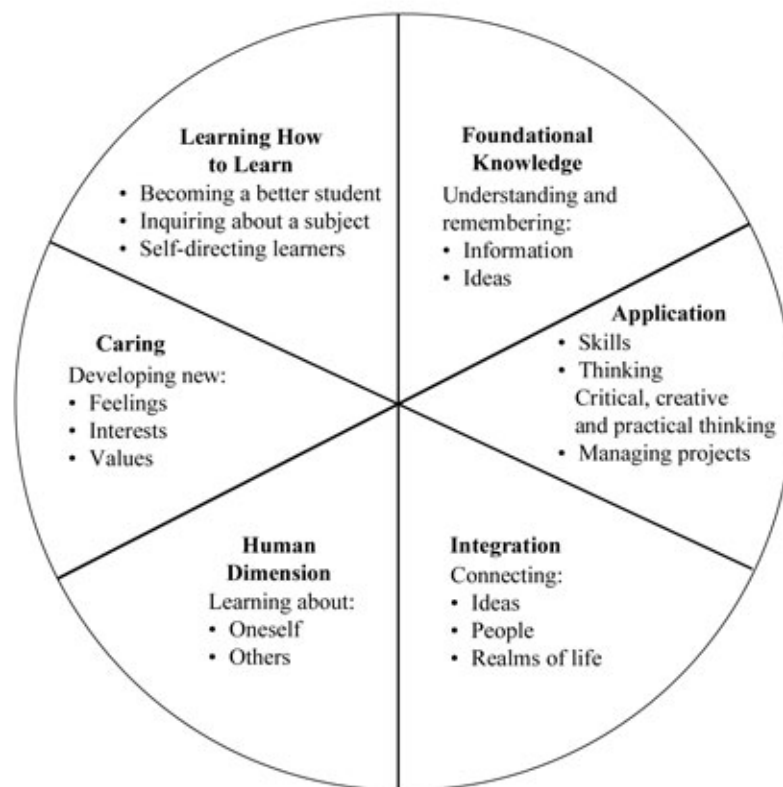

Figure 9. Fink's (1984) Taxonomy of Significant Learning. Reprinted from *Creating Significant Learning Experiences* (p. 30), by L. D. Fink, 2003, San Francisco, CA: Jossey-Bass, Copyright 1984 by John Wiley & Sons, Inc. Reprinted with permission.

Learning Styles

The learning structure purported by ELT is grounded in four learning modes – CE, RO, AC, and AE. Any one mode, or combination of modes, can govern learning at any given moment (Kolb, 1984). This complex learning process is not identical for everyone. As an individual seeks to resolve the conflicts associated with various experiences, there are preferences in the tools or learning modes that are used. “The dilemma for the scientific study of individual differences is how to conceive of general laws or categories for describing human individuality that do justice to the full array of human uniqueness” (Kolb, 1984, p. 63). Kolb (1984) warned of the formist epistemology of learning *types* that are viewed as *reality*. In practice and research, there is a marked tendency to view these learning styles as fixed traits (Garner, 2000). An alternative epistemological approach, of which Kolb (1984) subscribes, is contextualism, where the person is examined in the context of the event by which both the person and the event are shaped.

Drawing from Tyler’s (1978) possibility processing structures, Kolb (1984) explained that,

The implication of the contextualist worldview for the study of human individuality is that psychological types or styles are not fixed traits but stable states. The stability and the endurance of these states in individuals comes not solely from fixed genetic qualities or characteristics of human beings; nor, for that matter, does it come solely from the stable, fixed demands of environmental circumstances. Rather, stable and enduring patterns of human individuality arise

from consistent patterns of transaction between the individual and his or her environment. The way we process the possibilities of each new emerging event determines the range of choices and decisions we see. The choices and decisions we make, to some extent, determine the events we live through, and these events influence our future choices. (pp. 63-64)

Individual learners create *programs* for how they choose to process experiences. This program includes apprehension and/or comprehension preferences, as well as intention and/or extension preferences.

These preferences for grasping and transforming experiences have been captured psychometrically since 1971 through the Kolb Learning Style Inventory (KLSI) (Kolb, 1985, 1996; 1999, 2007). A four learning style model, as well as a nine learning style model, has been utilized. In this study, the emphasis is placed on the four learning style approach of the KLSI 3.1 (Kolb, 1999). The nine-style approach will also be introduced briefly, as it is simply a model including greater diversity in classification. The four learning styles are based on the four learning modes of ELT (Kolb, 1984). The most recent manual for the KLSI 3.1(1999) explained these four modes in a more practical way (see Table 1).

Table 1

KLSI 3.1 Description of the Four Phases of the Experiential Learning Process

Learning Mode	Description
Experiencing	Learning from specific experiences, being sensitive to feelings and people.
Observation	Observing before making judgments, viewing issues from different perspectives, looking for the meaning of things.
Thinking	Analyzing ideas logically, planning systematically, acting on an intellectual basis.
Action	Learning through hands-on activities, dealing with people and events through action.

The KLSI 3.1 (1999) results in one of four learning styles: diverging, assimilating, converging, and accommodating. An individual with the *diverging* style prefers to learn through feeling (CE) and reflecting (RO) primarily. In reference to Figure 10, this style is known as the creator. A person with this preference is best at viewing concrete situations from a myriad of perspectives. Divergent learners prefer to observe rather than take action, and enjoy situations that call for a wide range of feelings and ideas. In formal learning situations, a divergent learner would prefer to work in groups and needs to receive personalized feedback and attention (Kolb & Kolb, 2009).

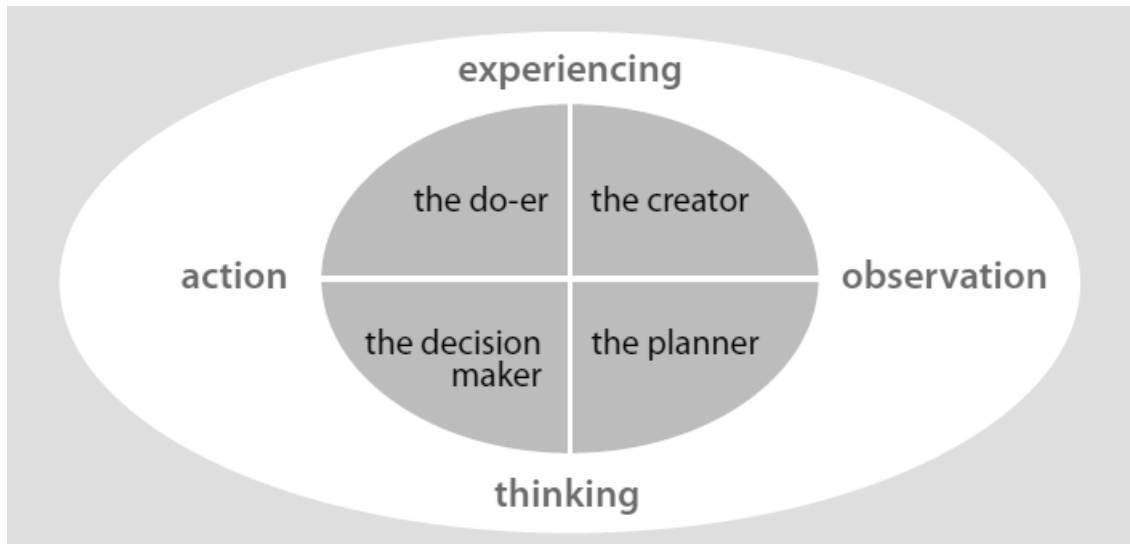

Figure 10. KLSI 3.1 Model of Experiential Learning Process. Reprinted from The Kolb learning style inventory – Version 3.1: LSI workbook. (p. 3), by David A. Kolb, 2007, Boston , MA: Hay Learning Transformations. Copyright 2007 by Haygroup. Reprinted with permission.

Learners with an *assimilative* style prefer to learn through thinking (AC) and acting (AE), and are referred to in Figure 10 as the planner. They like to make decisions based on logical reasoning, and deal with technical tasks rather than social and interpersonal issues. These individuals favor a theory is elegant and logical rather than being practical. Assimilators may desire to work alone, and do not make quick decisions but spend adequate time thinking through a problem before taking action. In formal settings, these learners prefer lectures, readings, exploring analytical models, and being given adequate time to think things through (Kolb & Kolb, 2009).

Learners with a *converging* style emphasize thinking (AC) and acting (AE), and are referred to in Figure 10 as the decision maker. Those who learn in this way find practical uses for ideas and theories. Like assimilators, they prefer to solve problems and

make decisions based on finding logical solutions. Interpersonal and/or ambiguous situations are not an area of strength, as feelings and reflection are not a modes of learning indicative of this style. In formal learning settings, a converging learner prefers to experiment with ideas. This includes simulations, laboratory based learning, and practical applications (Kolb & Kolb, 2009).

Finally, learners with an *accommodating* style learn through acting (AE) and feeling (CE) primarily, and are referred to in Figure 10 as the *doer*. This learning preference seeks hands-on experiences and is comfortable in ambiguous learning situations. Setting goals and meeting challenges is indicative of this style. These learners tend to go with their gut feelings and other people over a logical analysis of issues. They can be disorganized and can act before thinking because of their lack of fondness for reflecting and thinking. In formal learning settings, accommodators select to work in groups and find ways to accomplish the group goals. Fieldwork is preferred to theoretical discussions (Kolb & Kolb, 2009).

The work of David Hunt (1987) and associates (Abby, Hunt, & Weiser, 1985) demonstrated that the four learning styles could be expanded to nine, including a *northerner*, *easterner*, *southerner*, *westerner*, and a *balancing* learning style. This expanded definition of learning style is depicted in Figure 11, and increases the “resolution of the learning style type grid from four to nine pixels” which could “help deal with a common misconception of ELT learning styles: that is, the tendency to treat the four learning styles as four categorical entities rather than continuous positions on the dimensions of AC-CE and AE-RO” (Kolb & Kolb, 2005b, p. 198). As such, the learning styles have evolved from *diverger* to *diverging* to reflect this important distinction.

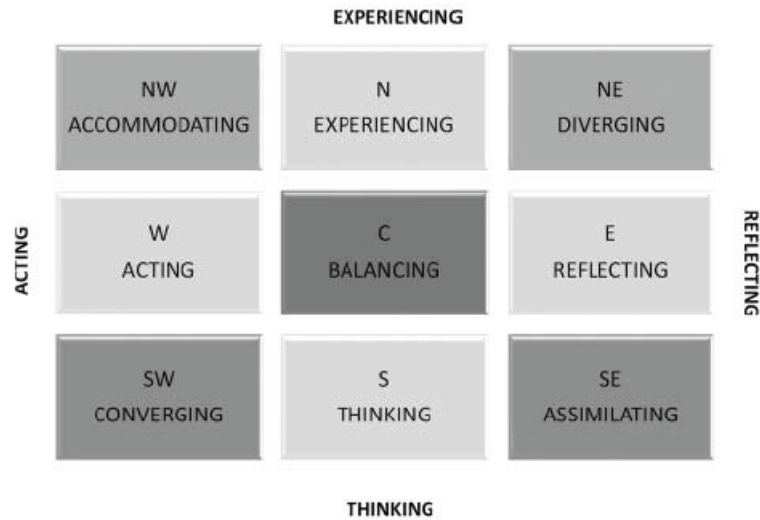

Figure 11. The Nine Regions of the Experiential Learning Theory Learning Space. Reprinted from *The Learning Way: Meta-cognitive Aspects of Experiential Learning*, by Alice Y. Kolb and David A. Kolb, 2009, *Simulation and Gaming*, 40, p. 322. Copyright 2009 Sage Publications.

The nine-style grid becomes the foundation for *learning spaces*, an important distinction within ELT (Kolb & Kolb, 2009). For learning to occur, space must be created for all four modes of learning. The concept of learning space, drawn from Lewin’s (1951) field theory, is expressed in secondary educational classrooms by the choices the instructor makes in terms of the content taught and method of delivery (Kolb & Kolb, 2009). Learning spaces are nested in the social system in such a way that the environment has an impact on the context of the space by which learning occurs. Bronfenbrenner (1977, 1979) described the ecology of learning as nested structures of learning. The *microsystem* refers to the here and now setting such as a course or classroom, while the *mesosystem* refers to the broader perspective including other classes, home life, and the family. The *exosystem* includes the formal and informal social

structures present in the immediate learning environment such as the rules, policies, and culture of the high school. Finally, the *macrosystem* speaks to the broader guidelines and the wider culture of education, the community, and the school which all influence a student's microsystem and mesosystem. It is important to maintain the concept of learning spaces as an instructor designs instruction to customize the space and compensate for both the instructor's and students' preferred styles of learning (Kolb & Kolb, 2009).

Direct Instruction

Direct instruction (DI) is known as the most longstanding and comprehensive instructional program in schools today (Begeny & Martens, 2006). DI is a skill-based instructional technique in which teachers promote sequential development of student competencies by following a scripted instructional routine and providing praise at appropriate times (Becker, 1992; Gersten, Carnine, & White, 1984). The prevalence of this method is a result of increased behavior problems, diverse student populations, and achievement pressures resulting from current legislation like the No Child Left Behind Act (2001). National curriculum companies, such as SRA/McGraw-Hill (N.D.), purported that

Direct Instruction programs use common instructional planning and consistent classroom routines to boost student skill mastery in reading, spelling, language arts, and mathematics. The programs provide concrete, clear curricula that have been highly successful in a wide variety of instructional settings nationwide. (p. 1)

The adoption of DI techniques followed a thorough base of research confirming the positive effects of the method.

DI has received national attention following the U.S. Department of Education's funded education evaluation called *Follow Through* (Bock, Stebbins, & Proper, 1977; Watkins, 1997). This longitudinal study, including 120 communities with annual participation of 75,000 students, measured the effect of a range of teaching methods, from constructivist to behavioral realms, on student achievement. Student achievement was operationalized as scores on the Metropolitan Achievement Test, Coopersmith Self-Esteem Inventory, and the Intellectual Achievement Responsibility Scale. The findings revealed that DI was superior to other methods in fostering basic reading, mathematics, and higher order conceptual skills (Adams & Englemann, 1996; Becker & Carnine, 1980). Thus, this method was thrust into public education and has had a dominant presence ever since.

The purpose of DI is to “teach subject matter efficiently so that all the students learn all the material in the minimum amount of time” (Watkins & Slocum, 2003, p. 75). The idealistic model of DI consists of five phases that allow teachers to scaffold instruction, gradually shifting the responsibility to the learner through directed practice and feedback (Joyce & Weil, 2000; Moore, 2007; Pearson & Gallagher, 1983; Rosenshine & Meister, 1992; Vygotsky, 1978). The five phases are as follows:

1. Orientation: Teachers are tasked with accessing students' prior knowledge of the content to be learned as well as outlining the general overview of the lesson and the goals of the lesson.

2. Presentation: This explicit phase of the method includes the identification of a specific strategy by the teacher, which is then taught to the students. Variability is important in presenting new information as well as consistently checking for understanding.
3. Structured Practice: Teachers begin to move the responsibility to the students by providing practice. Using new material, teachers scaffold instruction in a way that students cannot fail, but experience mastery in the objective.
4. Guided Practice: Students begin to move toward independence. Teachers use structured response techniques to ensure that every student participates and checks for the accuracy of their responses.
5. Independent Practice: In this final phase of instruction, students practice independently by working with a strategy or concept in new contexts and situations. Teachers monitor while students are asked to complete tasks on their own to demonstrate independent mastery.

Instruction is organized in such a way that it is fast paced and moves from the more concrete and simple concepts to the more abstract and difficult. Students work in groups, as designed by the instructor, to insure they are in a situation that matches their skill level and competence in the course. Another key characteristic of DI is the use of scripted presentations. “When we attempt to create performances of great complexity and we want consistently successful outcomes, we generally plan very carefully” (Watkins & Slocum, 2003, p. 87). As such, DI lesson plans employ detailed scripts with carefully developed explanations, examples, and wordings. The curriculum, found most commonly in schools today includes a *teacher guide*, specific questions, timed and

sequenced activities, and extension opportunities to relieve the teacher of the responsibility associated with field testing and planning the instruction (Watkins & Slocum, 2003). DI served as the comparison group in this study, as it is a dominant teaching strategy in schools today (Begeny & Martens, 2006).

Outcome Variables

In 1919, Stimson discussed that when considering a “square deal in vocational education” (p. 29), “general schooling [is] not enough”, “books and bulletins [are] not enough”, and “the farm [is] not enough” (pp. 29-30). Vocational and agricultural education has a long history of educating the whole child.

Vocational agriculture is not a narrowly conceived part of the curriculum, but its purpose likely has been abused. It is an attempt to give the individual those necessary experiences to enable him to keep an open mind in all problems and to change his procedures as he finds this necessary in a constantly changing social and economic world. (Fitzgerald, 1936, p. 70)

Over 70 years after Fitzgerald’s survey of vocational education was conducted, agricultural education found itself asking the same question once again, *What is the intended product of agricultural education?* Roberts and Ball (2009) extended the modern version of this debate in creating a conceptual model (see Figure 12) for agricultural subject matter as a *content* and *context* for teaching. This holistic approach, repeatedly noted in the agricultural education literature, illuminates an important question – *How is successful instruction defined in agricultural education?* The answer to this question holds implications for which outcome variables are of interest. Just as there is

no one way of teaching and learning, there is no one way of assessing students' achievement (Sternberg & Grigorenko, 2004).

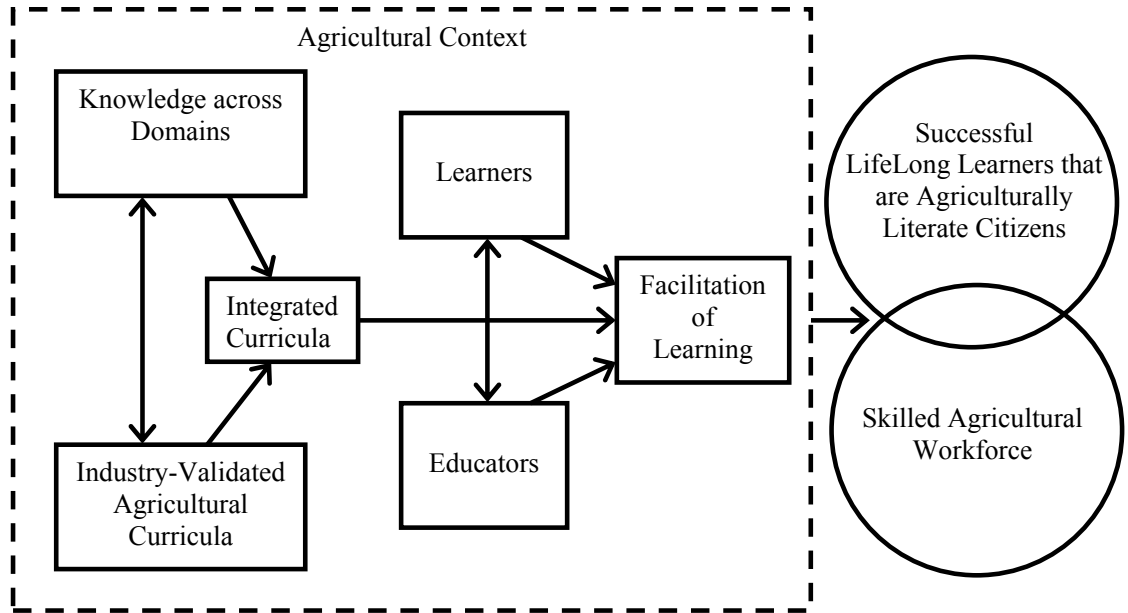

Figure 12. Roberts' and Ball's (2009) Conceptual Model for Agricultural Subject Matter as a Content and Context for Teaching. Reprinted from "Secondary Agricultural Science as Content and Context for Teaching" by T. Grady Roberts and Anna L. Ball, 2009, *Journal of Agricultural Education*, 50(1), p. 86.

Agricultural education is asked to wear many hats. The program has a responsibility to teach agricultural content and core academic concepts using agriculture as the context (Roberts & Ball, 2009). As made evident by the National Research Council in 1988, agriculture is faced with the challenge of not only producing career ready graduates in agriculture, but also students who can perform well in the climate of critical assessments. A number of secondary agricultural education models have been proposed (Hughes & Barrick, 1993; Phipps et al., 2008; Retallick, 2003), and a consistent theme of a broader perspective of learning has emerged that includes progression toward

successful contributions both academically and as a productive agriculturally minded citizen and/or employee. Sternberg (1999a) suggested that, “the time has come to move beyond conventional theories of intelligence” (p. 311), and as a result he developed a theoretical framework to clarify as to what *successful intelligence* is comprised. Winch (2010) extended Sternberg’s (1999a) sentiment to vocational education specifically.

One of the key features of any professional or vocational education worthy of the name is, not merely to enable individuals to attain a threshold level of competence that would allow us to say that they know how to do [a specific action], but also to introduce students of a craft, occupation, or profession to the standards of excellence [of that craft]. Vocational and professional curricula, and the teaching and learning of practical knowledge, require the use of such a conceptual framework if they are to be anything other than programmes for the acquisition of threshold competence. Bound up with the acquisition of expertise is something more than the mastery of technique (important though it is), the development of judgment and discretion in the application of technique and, in some circumstances, in the devising of techniques. (p. 566)

In essence, Winch (2010) described the analytical, creative, and practical nature of vocational education.

Sternberg’s (1999a) Theory of Successful Intelligence framed the outcome variables for this study. Thus, in the sections to follow, Sternberg’s (1999a) theory, and other outcome variables, will be discussed. Sternberg (1999a) listed four factors of learning that should be considered. The four factors are as follows:

- Analytical Intelligence: skills used to analyze, evaluate, judge, or compare and contrast.
- Practical Intelligence: skills used to implement, apply, or put into practice ideas in real-world contexts.
- Creative Intelligence: skills used to create, invent, discover, imagine, suppose, or hypothesize.
- Student Motivation: a result of teaching that reaches more students' patterns of abilities (Sternberg, 2006).

Sternberg's Theory of Successful Intelligence

Sternberg (1999a) purported that a construct of successful intelligence “better captures the fundamental nature of human abilities” (p. 292). This concept of intelligence stands in contrast to the conventional *g*, or general ability, views of intelligence that Sternberg (1999a) described as narrowly based and incomplete. The theory of successful intelligence is built on four elements: (a) Intelligence is defined in terms of the ability to achieve what an individual identifies as success within their sociocultural context. The use of societal criteria of success does not take into consideration the operationalization of success to an individual or culture. This has led to the mostly academic focus of intelligence, as led by Binet and Simon (1916); (b) A person's ability to achieve success is based on his or her ability to capitalize on personal strengths and to correct or compensate for weaknesses. Typically, theories of intelligence (Gardner, 1983; Spearman, 1904; Thurstone, 1938) specify factors that can be tested, but people achieve success in a myriad of ways; (c) Success is achieved through a balance of analytical, creative, and practical abilities. Analytical abilities are measured and

associated with traditional tests of abilities most often. However, success in life requires an individual to not only analyze his or her ideas, but also generate new ideas and convince others of the value of those ideas; and (d) Balancing of abilities is achieved to adapt to, shape, and select environments. Conventional notions of intelligence focus on an individual's ability to adapt to environments, but successful intelligence recognizes the need to modify the environment at times or choose to change the setting completely. Due to the three components of intelligence, it has been referred to as the *triarchic* theory of intelligence (Sternberg, 1999a).

Successful Intelligence: Theory to Praxis

Often, a large gap exists between a theory like successful intelligence and actual practice (Constas & Sternberg, 2006). As a solution to this threat, Sternberg (1998) designed forth 12 principles for translating theoretical ideas of successful intelligence to educational practice. The principles demonstrate the congruency between Kolb's (1984) and Sternberg's (1999a) pedagogical approaches. These 12 principles, juxtaposed with Kolb's ELT, are:

1. "The goal of instruction is the creation of expertise through a well and flexibly organized, easily retrievable, knowledge base" (Sternberg, 1998, p. 66). Kolb (1984) explained that "everyone enters every learning situation with more or less articulate ideas about the topic at hand" (p. 28), and that expertise occurs through the cyclical nature of experiential learning.
2. "Instruction should involve teaching for analytical, creative, and practical thinking, as well as for memory learning" (Sternberg, 1998, p. 66). Kolb (1984)

mirrors this idea in his competency circle that operationalizes each of the learning modes further.

3. “Assessment should also involve analytical, creative, and practical as well as memory components” (Sternberg, 1998, p. 66). Kolb’s (2009) Educator Role Profile outlines the important role of educators to assess each of the learning modes, which as mentioned in principle two, includes all three components of successful intelligence.
4. “Instruction and assessment should enable students to identify and capitalize on their strengths” (Sternberg, 1998, p. 67). Kolb (1984) discussed the idea of individuality in learning, and shared that students learn to transform and grasp information in ways consistent with their strengths.
5. Instruction and assessment should enable students to identify, correct, and, as necessary, compensate for weaknesses” (Sternberg, 1998, p. 67). Kolb (1984) explained that individuality in learning includes working in the four modes that are not preferred to build complexity in the learning processes inherent in the theory.
6. “Instruction and assessment should involve utilization, at various times, of all seven metacomponents of the problem-solving cycle, including (a) problem identification, (b) problem definition, (c) formulation of problem-solving strategies, (d) formulation of mental and external representations and organizations of problems and their associated information, (e) allocation of resources, (f) monitoring of problems solving, and (g) evaluation of problem

solving” (Sternberg, 1998, p. 68). Kolb (1984) made the same connection in noting similarities of conceptions of basic adaptive processes.

7. “Instruction should involve utilization, at various times, of at least six performance components, including (a) encoding of information, (b) inference, (c) mapping, (d) application, (e) comparing of alternatives, and (f) response” (Sternberg, 1998, p. 68). This would be compared to ways of transforming information in Kolb’s (1984) model.
8. “Instruction should involve utilization, at various times, of at least three knowledge-acquisition components, including (a) selective encoding, (b) selective comparisons, and (c) selective combination” (Sternberg, 1998, p. 69). Kolb (1984) explained these as methods of grasping information.
9. “Instruction and assessment should take into account individual differences in preferred mental representations, including verbal, quantitative, and figural, as well as modalities for input and output” (Sternberg, 1998, p. 69). This is similar to the idea of learning style preferences shared by Kolb (1984).
10. “Optimal instruction is in the zones of (a) relative novelty and of (b) automatization for the individual” (Sternberg, 1998, p. 69). Kolb (1984) added to this idea by explaining that the conflict created by new experiences is the driving force for learning, so long as it can be assimilated into some previous structure.
11. “Instruction should help students (a) adapt to, (b) shape, and (c) select environments” (Sternberg, 1998, p. 70). Kolb (1984) noted that comprehension is an objective social process, a tool of culture, based on the individual’s current environment.

12. “Good instruction and assessment integrate rather than separate all of the elements of intelligence” (Sternberg, 1998, p. 70). Kolb (1984) noted that it is essential to move through, develop, and assess at all four learning modes.

These 12 principles, connected to Kolb’s (1984) ELT, demonstrate the connection between experiential learning principles and those of successful intelligence. Sternberg and Grigorenko (2004) “encourage teachers to teach and assess achievement in ways that enable students to analyze, create with, and apply their knowledge. When students think to learn, they learn to think” (p. 275). But, what exactly does it mean to teach analytically, creatively, and practically?

Teaching Analytically

Teaching analytically means to ask students to (a) analyze, (b) critique, (c) judge, (d) compare and contrast, (e) evaluate, and (f) assess. This is most commonly what is associated with standard classroom procedures in the classroom climate of today (Sternberg, 1999b). Oftentimes, teaching analytically is connected to the idea of critical thinking (Sternberg & Grigorenko, 2004), and students are asked to apply concepts to familiar types of problems in which the judgments to be made are fairly abstract (Sternberg, 1999a). Through slight adaptation of the curriculum examples provided by Sternberg and Grigorenko (2004), examples of teaching agricultural education analytically could include the following:

- Analyze the changes that have occurred in agriculture over the past 100 years.
- Critique the design of the experiment (just learned in class or in a reading) showing that certain plants grew better in dim light than in bright sunlight.

- Judge a class of market steers, discussing the strengths weaknesses as a market animal.
- Compare and contrast the respective natures of the first National FFA Convention and the 85th National FFA Convention, pointing out ways they were similar dissimilar.
- Evaluate the validity of the following feed ration, and discuss weaknesses in the solution, if there are any.
- Assess the breeding strategy of a rancher by stating what techniques she used to manage her herd.

When comparing this type of teaching, a connection could be made to the *classroom* and *FFA* components of the three-circle model of agricultural education (Phipps et al., 2008), where students are taught abstract concepts and then are asked to use those concepts in various environments.

Teaching Practically

Teaching practically includes asking students to (a) apply, (b) use, (c) put into practice, (d) implement, (e) employ, and (f) render practical what they know (Sternberg & Grigorenko, 2004). This type of teaching must relate to the real practical needs of the student and not to other individuals. As done earlier, slight adaptations of the curriculum examples listed by Sternberg and Grigorenko (2004) provide examples of teaching agricultural education analytically:

- Apply the formula for computing fertilizer requirements to a problem faced by a given peanut producer.

- Use your knowledge of biotechnology to market a genetically modified food to a customer.
- Put into practice what you have learned about genetics by selecting a sire for use in your swine operation.
- Implement a business plan you have developed in a simulated business environment.
- Employ a financial formula for compound interest to determine the amount of interest to be paid.
- Render practical a proposed design of a windmill blade to convert wind energy to electrical energy most effectively.

Teaching practically aligns most closely to the Supervised Agricultural Experience (SAE) component of the three-circle model of agricultural education (Phipps et al., 2008), which focuses on a project where students are called to employ practically the concepts learned in the classroom to real-world settings.

Teaching Creatively

Teaching creatively includes asking students to (a) create, (b) invent, (c) discover, (d) imagine if..., (e) suppose that..., and (f) predict (Sternberg & Grigorenko, 2004).

Teaching creatively requires teachers to not only support creativity, but also model it and reward it. Once again, examples of teaching creatively in agricultural education, derived from suggestions made by Sternberg and Grigorenko (2004), could include:

- Create an alternative ending to the story of the 33 farm boys that created the FFA organization in 1928.

- Invent a dialogue between a legislator and an agriculturist one century from today.
- Discover the fundamental physical principle that underlies all of the following problems, each of which differs from the others in a surface structure, but not deep structure.
- Imagine if the sex of cattle could be determined through embryo fertilization and transfer.
- Suppose that you could create the corn varieties of the future. What might that variety look like?
- Predict changes that are likely to occur in the verbiage used to write the next farm bill.

Teaching creatively fits best in the SAE and FFA components of the model, as students create solutions for their own practical problems, and as they compete and prepare for National FFA events (Phipps et al., 2008).

Student Motivation

Though not one of the three core skills, student motivation has been discussed as a key product of teaching for successful intelligence. “Because teaching for successful intelligence reaches more students’ patterns of abilities, the students are more likely to be intrinsically motivated to succeed in their own work” (Sternberg & Grigorenko, 2004, p. 277). Most research on effective teaching and learning analyzes the performance of particular cognitive tasks and skills needed to complete those tasks (Dweck, 1986). This one-dimensional perspective, also referred to as a cognitivist view, fails to account for the

notion that “almost all human activity, including thinking, serves not one but a multiplicity of motives at the same time” (Neisser, 1963, p. 195). Motivation is defined generally as, “that which accounts for the arousal, direction, and sustenance of behavior” (Keller, 1979, p. 27).

“Seldom do the arguments about the boundaries of teachers’ responsibilities, or whether teaching is an art or science, become more animated than when discussing the motivation of students” (Keller, 1987, p. 2). However, the idea of motivation in the classroom is complex and educators, in general, struggle to move from theory to practice when seeking to improve motivation. As such, Keller (1987) asked two fundamental questions: (a) Is it possible to synthesize numerous concepts and theories of motivation into a simple, meaningful model or schema that would be useful to the practitioner?, and (b) Is it possible to develop a systematic approach to designing motivating instruction? These questions led to the development of the ARCS Model (Keller, 1984) designed to improve student motivation through better instruction. ARCS represent the four conceptual categories of motivation: (a) attention, (b) relevance, (c) confidence, and (d) satisfaction (see Figure 5). The ARCS model is based on the macro theory of motivation and instructional design developed by Keller (1979, 1984), and is grounded in the expectancy-value theory, as defined by Tolman (1932) and Lewin (1938).

Expectancy-value theory (Eccles et al., 1983) is built on the work of Atkinson (1957), Battle (1966), Crandall (1969), Feather (1992), and Wigfield and Eccles (1989). It has been one of the most important views on the nature of achievement motivation in the classroom (Wigfield, 1994). The theory explains that people are motivated to engage in an activity if it is perceived to be in alignment with one’s personal needs – the *value*

aspect. In addition, students have expectancies for success, which is defined, as the individual's beliefs about how well he or she will perform on an upcoming task – the *expectancy* aspect. In the original ARCS model (Keller, 1979), value and expectancy framed the four conceptual categories. Subdividing the value category into two categories called interest and relevance further distinguished constructs dealing primarily with curiosity and arousal and those focusing on a need for achievement. Expectancy remained, and the final category was named outcomes, referring to the reinforcing value of instruction. Each category was renamed in the modern ARCS model (Keller, 1984) as to strengthen the central feature of each component and to generate a useful acronym.

The ARCS model defines four major conditions that have to be present for people to become and remain motivated. Keller's (1987) operationalization of the four conditions is depicted in Figure 13. Attention is the first of these conditions and is a prerequisite for learning. The motivational goal is to not only get students' attention, but to sustain it over time. Relevance is related to answering the question, "Why do we have to learn this?" This condition can come from the way something is taught, and is not dependent solely on the planned curriculum. Confidence refers to the differences in students' belief that they can achieve. This is connected tightly to Dweck's (1986) research related to entity and incremental beliefs of a person's ability. Confident students believe they can accomplish their goals by means of their actions (Bandura, 1977; Bandura & Schunk, 1981), while students who exhibit low confidence have more of an ego involvement, leading to a desire to impress others and avoid failure (Dweck, 1986).

Categories & Subcategories	Process Questions
Attention	
A.1. Perceptual Arousal	● What can I do to capture their interest?
A.2. Inquiry Arousal	● How can I stimulate an attitude of inquiry?
A.3. Variability	● How can I maintain their attention?
Relevance	
R.1. Goal Orientation	● How can I best meet my learner's needs? (Do I know their needs?)
R.2. Motive Matching	● How and when can I provide my learners with appropriate choices, responsibilities, and influences?
R.3. Familiarity	● How can I tie the instruction to the learner's experiences?
Confidence	
C.1. Learning Requirements	● How can I assist in building a positive expectation for success?
C.2. Success Opportunities	● How will the learning experience support or enhance the students' beliefs in their competence?
C.3. Personal Control	● How will the learners clearly know their success is based on their efforts and abilities?
Satisfaction	
S.1. Natural Consequences	● How can I provide meaningful opportunities for learners to use their newly acquired knowledge/skill?
S.2. Positive Consequences	● What will provide reinforcement to the learner's successes?
S.3. Equity	● How can I assist the students in anchoring a positive feeling about their accomplishments?

Figure 13. Keller's (1987) Motivational Categories of the ARCS Model. Reprinted from "The Systematic Process of Motivational Design" by J. M. Keller, 1987, *Performance and Instruction*, 26(8), p. 86.

Finally, satisfaction incorporates the factors that make students feel good or bad about their accomplishments. Students are more satisfied if the task reward is clear and effective reinforcement is delivered.

Following the development of the ARCS model, Keller (2006) exerted two motivational measurement instruments. The first instrument is called the Course Interest Survey (CIS), and the second is the Instructional Materials Motivation Survey (see Appendix L; IMMS). “Both surveys are situational measures of students’ motivation to learn with reference to a specific learning condition such as an instructor facilitated learning environment, a self-paced print module, or a self-directed e-learning course” (Keller, 2006, p. 1). The goal of these measures is not to capture students’ generalized levels of motivation toward school learning, but rather to find out how motivated students are, were, or expect to be, by a particular course. Keller (2006) expects these measures can be effective in assessing the motivation of secondary education students within the ARCS framework.

Student motivation is the final element that is associated with the broader view of achievement purported by Sternberg (1999a) in his theory of Successful Intelligence. These elements of performance are helpful in casting a broader net when seeking to understand the effects of instructional methods better. But is this view of intelligence internally and/or externally valid?

Empirical Support for the Theory of Successful Intelligence

Sternberg and Grigorenko (2004) provided four reasons to support the use of successful intelligence as a framework for teaching and learning. First, instruction based

on these principles leads to more elaborated encoding of material than a more traditional approach. This improves the chance of recall during an assessment. Second, teaching experientially or for successful intelligence provides a more diverse set of options for encoding material. This diversity leads to more opportunities for activation of previously built networks and thus better retention. Third, students can capitalize on their strengths and mitigate their weaknesses in a way to grasp and transform knowledge best. Finally, this type of instruction is more motivating to teachers and students, leading to more effective teaching and learning.

These assertions have been confirmed empirically. Empirical examinations have confirmed the utility of the theory of successful intelligence, specifically in the context of educational settings. Three studies (Sternberg & Clinkenbeard, 1995; Sternberg, Ferrari, Clinkenbeard, & Grigorenko, 1996) found that all three ability tests – practical, analytical, and creative – significantly predicted course performance. A follow-up study (Sternberg, Torff, & Grigorenko, 1999) included students being assigned randomly to one of three conditions: (a) a course focused on memory, (b) a course focused on analytical thinking, and (c) a course focused on analytical, practical, and creative thinking. Congruent to the theory of successful intelligence, students in the third treatment, including all three types of intelligence, outperformed their peers on performance assessments. Further, it was found that teaching based on these principles was successful regardless of the subject (Sternberg & Grigorenko, 2004).

In addition to the external validity discussed earlier, Sternberg (1999a) spoke to the internal validity of this three-factor approach to intelligence. One study (Sternberg, Grigorenko, Ferrari, & Clinkenbeard, 1999) used the Sternberg Triarchic Abilities Test

(STAT; Sternberg, 1993) to assess the internal validity of the theory. Through confirmatory factor analysis, the triarchic view of human intelligence was supported, as three factors emerged with small correlations between the factors. In two subsequent studies (Grigorenko & Sternberg, 2001; Sternberg, Castejón, & Prieto, 2001), including populations from varying nationalities, this three-factor solution to intelligence remained stronger than that of a one factor *g* view of intelligence.

Effects of an Experiential Approach to Learning

This review of literature has made clear what experiential learning is, how it is operationalized in classrooms, and the importance of measuring the outcomes in a broader way than mere achievement on a test. But, what empirical evidence exists supporting the use of experiential learning? Kirschner et al. (2006) would say little to none. “None of the arguments [against experiential approaches] and theorizing would be important if there was a clear body of research using controlled experiments indicating that unguided or minimally guided instruction was more effective than guided instruction” (Kirschner et al., 2006, p. 79). Unfortunately, a review of literature related to experiential learning approaches to teaching confirms this sentiment. In fact, a substantial amount of evidence against this *unguided instruction* has established a solid research-based case against the method (Kirschner et al., 2006). Even advocates of experiential learning (Gass, 2005) have conceded the need to develop more evidence-based models for experiential learning, noting confounding variables as a major barrier to the empirical validation of the theory of experiential learning (Ewert & Sibthorp, 2009). No studies linking experiential learning directly to Sternberg’s (1999a) concepts of successful intelligence were found.

Despite this paucity of research, a number of studies have provided support for experiential learning. One source of evidence comes from literature in service learning as an experiential component of liberal education. Eyler (2009) purported that experiential learning has value that extends far beyond the building of social skills, work ethic, and practical expertise. Experiential learning leads to a deeper understanding of subject matter, builds the capacity for critical thinking and application of knowledge in complex or ambiguous situations, and supports the ability to engage in lifelong learning (Eyler, 2009). A study by Eyler and Halteman (1981) found that students involved in an experiential section of a course on legislative politics scored the same on a traditional examination, but when asked to transfer that knowledge to other settings showed significant gains in the practical use of the information.

In subsequent studies, Eyler and Giles (1999) found that students involved in an intensive, highly reflective service-learning course showed statistically significant increases in reflective judgment at the end of the course when compared to those in a traditional classroom setting. The study employed problem-solving interviews where students were asked to demonstrate their reasoning abilities. Steinke and Buresh (2002) synthesized experiential learning research in the context of service learning and confirmed the idea of a deeper understanding and more complex working knowledge resulting from more experiential curriculums. In this synthesis, the effect of experiential approaches were broken down into various products, such as course performance, creativity, and critical thinking.

In terms of course performance, research has found that students involved in an experiential curriculum achieved higher outcomes than those in non-experiential courses

(Markus, Howard, & King, 1993). Berson (1997) measured student performance based on course grades, course attendance, and course completion, and found only course grades were statistically better for the experiential group. However, studies by Kendrick (1996) and Miller (1994) failed to replicate these studies and found students in experiential learning treatments performed at, or below, peers in more direct courses. Kendrick (1996) examined two undergraduate courses, of which one required extensive experiential learning components, and found that course grades did not differ between the two groups. Cohen and Kinsey (1994) reported higher self-report of motivation but showed no statistically significant difference in course performance. Osborne, Hammerich, and Hensley (1998), as shared in a synthesis of research by Steinke and Buresh (2002), included discussion of the effects of experiential learning on creativity. A study utilizing a sample of 92 undergraduate students enrolled in a communication course were assigned randomly to traditional lecture or experiential learning sections. Utilizing a Remote Associates Test (RAT), a standard measure of creativity, statistically significant differences were found in favor of the experiential treatment.

Specht and Sandlin (1991) utilized a sample of 46 college students in a college accounting class to determine the effect of experiential learning approaches on retention of knowledge. Twenty-two students were assigned randomly to the section that included an experiential learning activity, while the remaining 24 students were assigned to the second section and received the standard lecture-based instruction. Through the use of unannounced quizzes, students' performance was assessed following the completion of the lesson and six weeks following the delivery of the instruction. The scores were not significantly different directly following instruction, but were significantly different six

weeks following instruction in favor of those who received instruction through experiential learning activities.

Stout (1996) turned from the more cognitive focus of experiential learning to the affective domain. Utilizing a sample of 283 students assigned to an experiential treatment, including case analysis and team accounting simulations, the researchers administered a questionnaire targeting the affective elements of the course twice to determine stable effects. Findings included: (a) experiential students rated the course highly with respect to its perceived impact on the attractiveness of accounting as a profession, (b) the experiential group impacted the learning process positively, (c) the experiential component of the course was determined to be the most satisfactory to students, (d) the course experience had a salutary effect on career specialization intentions, and (e) student perceptions were relatively stable between the two administrations of the questionnaire.

A similar study (Weinberg, Basile, & Albright, 2011) assessed the effect of a summer enrichment program, grounded in experiential learning opportunities, intended to increase student motivation in science and mathematics. A sample of 336 students was asked to complete the Science and Mathematics Student Motivation Assessment (SMSMA) following the experiential treatment. The SMSMA measures interest value, utility value, cost value, attainment value, and expectancy for success. Through the use of paired samples *t*-test, it was found that students became more interested and developed a higher expectancy for success for mathematics, but reported a lower attainment value following the experience, indicating that math did not define them as a person. In science, statistically significant gains were found in student interest, perceptions of

usefulness, importance of science in defining themselves, and expectations for future success in science.

Abdulwahed and Nagy (2009) conducted one of the only studies that tested Kolb's (1984) experiential learning theory, specifically, in relation to student performance. The researchers divided 70 engineering students into two groups. One group received the standard engineering based instruction including performance based lab assessments. The second group received a modified curriculum that was designed to match Kolb's (1984) experiential learning cycle specifically. It was suspected that the issue of performance was based on the lack of activation in the prehension dimension of the cycle. Following eight weeks of instruction treatments, it was concluded "students who had better activation of the prehension dimension prior to the lab session had more in-depth learning during the hands-on lab session" (Abdulwahed & Nagy, 2009, p. 289).

Consistent with other fields, experimental research in agricultural education seeking empirical support for experiential learning is limited. Specific to agricultural education, the majority of evidence related to experiential learning is found in connection with Supervised Agricultural Experience Programs (SAE). Research studies consistently found a relationship between involvements in SAE programs and performance on agricultural competency examinations (Cheek et al., 1994; Cheek & McGee, 1985; Kotrilik, Patton, & Leile, 1986). Further, Anyadoh and Barrick (1990) noted a statistically significant relationship between SAE involvement and academic achievement, as measured by students' GPA. Though a person might question the moderation of other variables in these studies, it does provide an indication that

involvement in the highly experiential component of the agricultural education program could have an effect.

Chapter Summary

Chapter two provided a broad perspective of the literature base pertinent to the examination of experiential learning. The chapter began with the historical context relating to experiential learning in agricultural education. Literature provided evidence that schools in America are seeking transformation and are being asked to be more effective in developing STEM competence. Broad perspectives of experiential learning were presented as a lead-in to the theoretical framework of the study, Kolb's (1984) ELT. Independent variables were explained, which included experiential learning as a teaching method, learning styles as defined by Kolb (1999), and perspectives of DI. Outcome variables were discussed, based on Sternberg's (1999a) theory of successful intelligence. Finally, a review of studies aiming to understand the effect of experiential learning was presented. Chapter III focuses on the methodology of this study as it seeks to answer three research questions:

1. What interactions exist between students' preferred learning styles, successful intelligence, and the instructional approach chosen?
2. What statistically significant differences exist in students' successful intelligence and motivation for the course between experiential learning and direct instruction approaches?
3. Do the analytical effects achieved by experiential and direct instructional approaches persist over time?

CHAPTER III

METHODOLOGY

This study used a completely randomized factorial (CRF-22), and a split-plot factorial (SPF-2•3) experimental design to determine the effects of utilizing instruction based on Kolb's (1984) Experiential Learning Theory on secondary agricultural education students' successful intelligence (Sternberg, 1999a) and motivation for learning course content. Chapter one provided a brief background of experiential learning in educational settings established the need for the study, set forth the three research questions, and defined key terms relevant to the study.

Chapter two reviewed research relevant to experiential learning and the study, such as direct instruction, educational effects of experiential learning, and successful intelligence, and introduced Kolb's (1984) ELT. Variables discussed included students' successful intelligence (Sternberg, 1999a), defined as students' creativity, practical skills, and analytical skills, and motivation.

Chapter three explains the methods employed to answer the following three research questions:

1. What interactions exist between students' preferred learning styles, successful intelligence, and the instructional approach chosen?
2. What statistically significant differences exist in students' successful intelligence and motivation for the course between experiential learning and direct instruction approaches?
3. Do the analytical effects achieved by experiential and direct instructional approaches persist over time?

The population of interest, a description of the participants, instrumentation, data collection, fidelity, and analyses chosen will also be discussed.

Research Design

This study utilized an experimental design. An experimental design “refers to a plan for assigning subjects to experimental conditions and the statistical analysis associated with the plan” (Kirk, 1995, p. 1). Experimental research is identified by a number of interrelated activities:

1. Formulation of statistical hypotheses that are germane to the research questions of interest.
2. Determination of experimental conditions including the independent and dependent variables, while planning for control of nuisance variables.
3. Specification of the number of subjects required and the population from which they will be sampled.

4. Specification of the procedure for randomly assigning subjects to experimental conditions.
5. Determination of the statistical analysis that will be performed (Kirk, 1995).

Stevens (2009) shared two reasons why using more than one dependent variable when comparing two treatments is important: (a) “any treatment ‘worth its salt’ will affect the subjects in more than one way – hence the need for several criterion measures,” and (b) “through the use of several criterion measures we can obtain a more complete and detailed description of the phenomenon under investigation...” (p. 145). The concept of experiential learning as a teaching method has, at times, been a somewhat difficult treatment to understand fully (Roberts, 2012); thus, a multivariate design is essential. There are four statistical reasons supporting this decision. First, a multivariate approach reduces the inflated overall Type I error rate over that of a univariate statistical analysis. Second, a multivariate approach incorporates the correlations into the test statistic where univariate analysis ignores the interaction and views that variance as error. Third, though univariate statistics may at times be insignificant separately, a multivariate approach can differentiate between the set of variables through analysis of joint effects. Finally, the canceling out effect that occurs with various univariate analyses is mitigated with a multivariate approach (Stevens, 2009).

This study employed two experimental designs to answer the three research questions driving the study. To answer the first two questions related to simple main and main effects of the treatment and comparison group, two completely randomized factorial two by two (CRF – 22) multivariate analyses of variance (MANOVA) were employed

(see Figure 14). The factorial design included learning style on one axis and treatment group on the other. The experimental design followed this model:

Treatment	R	X ₁	O ₂

Comparison	R	X ₂	O ₂

Participants were randomly assigned to either the treatment or comparison group and participated in their respective treatments. Following either treatment, O₂ included four assessments including a creative, practical, analytical, and motivation measure.

One of the CRF – 22 MANOVA’s served as the main analysis, and the second served as a procedural check, as suggested by Stevens (2009). Grouping learning style by the mode of transformation and by the mode of grasping, instead of the four conventional learning styles, allowed learning preference to be assessed while maintaining adequate sample size for powerful analyses. The unique specification of learning style is described further in the procedure section of this chapter. This is important to note in interpreting the results in chapter IV, as both MANOVA’s are reported.

CRF-22 MANOVA #1

	Experiential Learning	Direct Instruction
Grasp via Apprehension	Treatment Group A <i>n</i> = 26	Treatment Group B <i>n</i> = 31
Grasp via Comprehension	Treatment Group C <i>n</i> = 12	Treatment Group D <i>n</i> = 11

CRF-22 MANOVA #2 (Procedural Check)

	Experiential Learning	Direct Instruction
Transform via Extension	Treatment Group A <i>n</i> = 24	Treatment Group B <i>n</i> = 29
Transform via Intention	Treatment Group C <i>n</i> = 14	Treatment Group D <i>n</i> = 13

Figure 14. Random assignment of participants into two CRF-22 designs.

Research question two, which was seeking to determine if any analytical effects found in research question one and two were sustained six weeks later, utilized a split-plot factorial two by three (SPF-2•3) MANOVA. The SPF-2•3 provided analysis of the repeated analytical measures over time. “Repeated measures is...the natural design to use when the concern is with performance trends over time” (Stevens, 2009, p. 413). Also by blocking by individual, the error variance attributed to individual differences was removed. The repeated design measure proceeded as follows:

Treatment	R	O ₁	X ₁	O ₂	O ₃

Comparison	R	O ₁	X ₂	O ₂	O ₃

As noted, participants were randomized to either the treatment or comparison groups and completed an analytical pre-test prior to the treatment. An Analytical Wind Energy Assessment (AWEA) post-test followed the treatments immediately, and a deferred analytical post-test was collected six weeks after the treatment occurred.

Population

The population of interest in this study was all students enrolled in the participating secondary agricultural education program ($N = 120$). The agricultural education program is in a rural community with a population of approximately 46,000 people (www.city-data.com/city/Stillwater-Oklahoma.html). The entire program was chosen to attempt to assess a representative sample of a *typical*, holistic, agricultural education program in Oklahoma. This somewhat isolated population, though limiting in generalizability, provided additional control of nuisance variables associated with varying social contexts of communities and schools. From this population, a sample of 80 participants completed IRB consents and assents and participated in the full study. Of the 80 participants, 38 were assigned to the treatment group and 42 to the comparison group. Equal sample sizes were sought, however, assent forms restricted that from happening on the day of the experiment.

Description of Participants

Though not included as a research question, sex, grade in school (and thus relative age), race, and years in agricultural education are reported in Tables 2 – 5, as they are useful in understanding the sample utilized in this study.

Table 2

Gender by Treatment Group

Sex	Treatment		Comparison		Total	
	<i>n</i>	%	<i>n</i>	%	<i>n</i>	%
Male	15	39	23	55	38	48
Female	23	61	19	45	42	52
Total	38	100	42	100	80	100

Table 3

School Grade by Treatment Group

Grade	Treatment		Comparison		Total	
	<i>n</i>	%	<i>n</i>	%	<i>n</i>	%
9	16	42	19	45	35	44
10	6	16	6	14	12	15
11	11	29	9	22	20	25
12	5	13	8	19	13	16
Total	38	100	42	100	80	100

Table 4

School Race by Treatment Group

Race	Treatment		Comparison		Total	
	<i>n</i>	%	<i>n</i>	%	<i>n</i>	%
African American	2	5	1	2	3	4
Hispanic	3	8	1	2	4	5
White	33	87	37	89	70	88
American Indian	0	0	3	7	3	4
Total	38	100	42	100	80	100

Table 5

Years in Agricultural Education Grade by Treatment Group

Years	Treatment		Comparison		Total	
	<i>n</i>	%	<i>n</i>	%	<i>n</i>	%
1	18	47	14	33	32	40
2	9	24	13	30	22	28
3	5	13	6	14	11	13
4	6	16	7	17	13	16
5	0	0	2	5	2	3
Total	38	100	42	100	80	100

Procedures

Stevens (2009) warned, “no analysis, no matter how sophisticated, can compensate for poor data collection and measurement” (p. 38). Careful attention was given to creating an experiment as clinical in nature as possible to control for as many nuisance variables as possible. As is required, the procedure began with the designing of the experiment and the submission of an application to the Internal Review Board (IRB) of both Oklahoma State University and Stillwater Public Schools. Both boards approved the research, and the IRB documents associated with this approval are included in Appendices A through G. Recruitment, as well the consent and assent process, then followed the approved protocol. Eighty students agreed to participate in the study.

Approach to Analyzing the Effect of Learning Styles

One week prior to the experiment, Kolb’s (1999) Learning Style Inventory Version 3.1 (Kolb, 2007) was administered to each of the students who agreed to participate in the study. This instrument was scored, and a data source of subjects with the specified learning style was identified. It was found that certain learning styles had inadequate sample sizes to achieve adequate statistical power (see Figure 15). However, when learning style was viewed as preference for the two dialectically opposed ways of transforming experience, adequate sample size was achieved. A procedure was then employed to view learning style in a two-dimensional way rather than the standard four-dimensional manner outlined by Kolb (2007). This procedure required that participants be classified based on their preferences for grasping information and their preferences for transforming information. Each participant was assigned two learning preferences, and

the statistical analysis included participants' preferences for grasping and transforming information. This analysis not only provided procedural checks (Stevens, 2009), but also allowed the examination of the role of learning style with adequate sample size and thus power.

Conventional Four Learning Style Framework (Kolb, 2007)

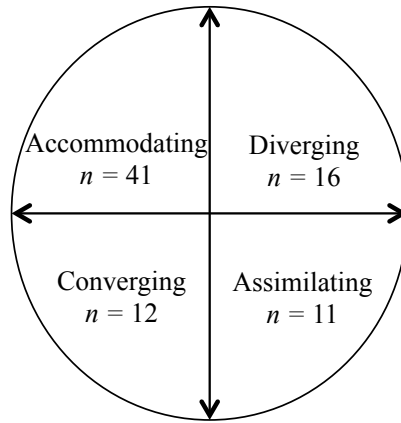

Viewing Learning Style by Transformation

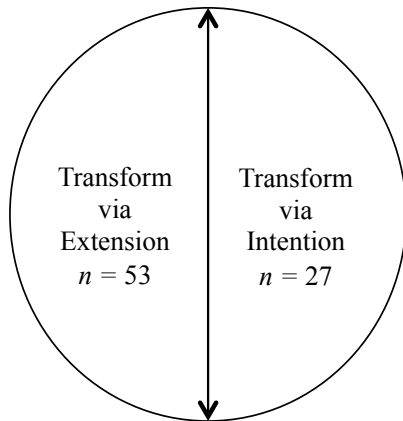

Viewing Learning Style by Grasping

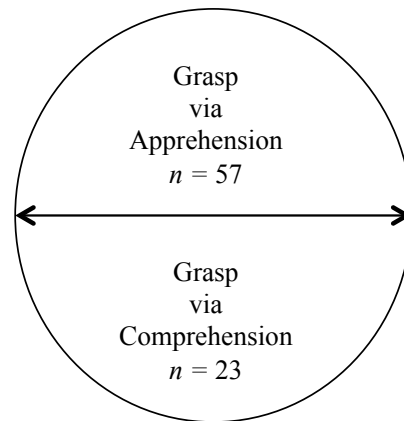

Figure 15. Visual Representation of Learning Style Interpretation and Sample Sizes for Each Distinction Achieved in the Study

Sampling Procedure

To ensure equal proportions of the learning styles in both the treatment and comparison groups, a stratified random sample was utilized (Gay et al., 2009). Stratified random sampling is a way to guarantee desired representation of relevant subgroups, and is effective when the research goal is to compare the behavior of participants between various strata (Gay et al., 2009). To analyze the effect learning style might have with adequate power, learning style was viewed in the two-dimensional fashion explained earlier. A free online resource, www.randomizer.org (Urbaniak & Plous, 2011) was utilized to randomize the subjects. Final analysis sample sizes can be seen in Figure 15. Though approximately equal sample sizes were proposed originally, there were a number of subjects ($n = 9$) who had to be removed because of instrument errors.

Development of the Treatment and Comparison Instruction

Wind turbine blade design was the content of interest for the experiment. This subject was chosen purposefully as it was congruent with course objectives for agricultural education and included adequate science, technology, engineering, and mathematics (STEM) concepts. The goal was to provide a full unit of instruction, which typically, would be taught over the course of one week in an instructional setting, during a four-hour period to maintain the experimental control. Through collaboration with a KidWind® consultant, educational objectives and materials were identified to that end. The curriculum followed closely the pre-existing KidWind® curriculum and involved the ordering of 25 Basic Wind Experiment Kits and related materials, as suggested by KidWind®. These materials can be viewed at www.kidwind.org.

Though the educational objectives and instructional materials were identical for both conditions, the delivery reflected the conventions of both direct instruction and experiential learning. For example, the Basic Wind Energy Kits were used in both treatments but in different ways. In the direct instruction comparison group, the kit was used to demonstrate various blade designs in according to the corresponding learning objective. In the experiential treatment group, the same kits were utilized as designed student experiences, where students interacted with various blade designs and then reflected on their concrete experience. Therefore, the treatments had the same goal, but used different instructional approaches to ensure potency of treatment. The curriculum and support materials for both conditions can be seen in their entirety in Appendix P and Q.

Professional Development and Assignment of Instructors

Weiss (2010) addressed the difficult issue of teacher selection and teacher effect in experimental designed studies of educational interventions. “It may be important to randomize teachers to experimental conditions for reasons that are very similar to the reasons why researchers randomize students to experimental conditions” (Weiss, 2010, p. 384). Based on this suggestion, eight instructors were randomly assigned to the two experimental conditions so that each condition had a lead instructor and three assistant instructors. Because both direct instruction and experiential learning instructional approaches require feedback, guidance, and support, it was determined that four instructors would insure fidelity and potency of the treatment. The lead instructors included two professors from similar backgrounds, trained pedagogically in the same academic department, from the same region, with similar years of teaching experience,

and both involved in the teacher education program at Oklahoma State University. The six assistant instructors were third year pre-service agricultural educators who were recruited to assist in the study (see Appendix G).

Prior to the experiment, each instructor was involved in a four-hour professional development session that included pedagogical training on the treatment corresponding to his or her respective assignment, as well as content knowledge training on blade design. The pedagogical training focused on the detailed lesson plans that were to be followed during the experiment and was conducted separately for each treatment condition. Each lesson plan stated explicitly the unique features of each instructional approach (see Appendix P and Q). The content knowledge was provided to all eight instructors, as a group, to avoid potential differences in training and was delivered by a consultant from the KidWind® Organization. This instruction focused on delivering the content knowledge outlined in the objectives of the instruction for both treatment conditions (see Appendix O), and concluded with a basic assessment of content knowledge using the post-test (see Appendix I) that would later be administered to all participants, regardless of which treatment condition they were assigned. All instructors expressed competence in their knowledge of the content and the pedagogical delivery method of their assigned treatment condition prior to their involvement in the experiment.

Delivery of Treatment and Comparison Instruction

The experiment occurred at a local community building that provided separation of the two experimental groups to reduce threats to validity related to socialization of samples. Two rooms in two different buildings were selected purposefully. Once

students arrived, they received a nametag indicating their respective room, were escorted to that room, and interacted only with the assigned group for the entire duration of the experiment. On arrival to the room, students were asked, individually, to complete the analytical pre-test (see Appendix H). The four instructors moderated this assessment. Once all AWEA pre-tests had been completed in both conditions, instruction began and followed the instructional plan corresponding to the condition. A complete description of the instruction plan is provided in Appendix P and Q, but a brief overview of the instructional approach is provided in Table 6.

Once the planned instruction had been completed, students were provided the AWEA post-test immediately (see Appendix I), and the IMMS (see Appendix L). Once those instruments were completed, students were provided lunch in the room where the instruction occurred. Instructors interacted with students and ensured that they did not interact with the curriculum or discuss the learning experience with one another. After lunch, students began the authentic assessment intended to measure both creative and practical use of the instruction. Each student was required to develop an individual plan outlining the blade design they would build (see Appendix M). This was done to maintain the individual unit of analysis and avoid the inflation of Type I error rates associated with dependency of data, as discussed by Stevens (2009). Once the student plan was presented to the instructors, they were given the supplies noted in the plans and were allowed to begin building their blade design individually.

Table 6

Brief Overview of Instructional Plan for Two Conditions of Instruction

Experiential Learning Instructional Approach	Direct Instruction Instructional Approach
Students interacted with six stations related to key concepts of blade design where instructors served as facilitators.	Students received three instructional sessions targeting specific learning goals.
Students were asked to reflect on each station using two questions: (a) What is happening? (b) What does this teach you as you build your own blade design? Instructors facilitated this reflection and provided expertise of subject content.	Instruction was based on a scripted lesson plan focused on developing mastery of the objectives put forth in the plan. This plan included pre-planned discussion questions and learning activities.
Students utilized abstraction sheets to connect their reflective observations to abstract concepts outlined in the objectives. Instructors served as content experts.	Instructors provide critical information followed by a chance for students to practice use of that knowledge in a large group, smaller group, and then alone.
Students were allowed to actively experiment with their own conclusions by building and testing a number of blade designs using KidWind® materials. Instructors served as evaluators and coaches.	Instructors provide immediate and constant praise based on student performance. KidWind® materials were used to demonstrate key principles.

Once designed, each student brought his or her blade design to a measurement station to be assessed. These stations were standardized to ensure that each turbine in both conditions was measured in a consistent manner. This included the distance in

which the turbines were placed from the fan, the speed of the fan, and the height of the wind turbine. Each blade design was connected to a Basic Wind Turbine KidWind® base that included a small generator connected to the hub. Using a voltage meter, the voltage reading of each blade design was recorded as a practical measurement. In addition, two pictures were taken of each blade design to assess creativity.

Deferred Analytical Post-Test

In the often cited Specht and Sandlin (1991) study, retention of knowledge was defined as six weeks following instruction. As such, a deferred analytical post-test (see Appendix J) was administered to participants of the study six weeks after the treatment so that results could be compared. This assessment was administered in the secondary school setting by the agricultural education instructors.

Instrumentation and Data Collection

The case was made in Chapter I that how individuals define intelligence should be expanded (Sternberg, 1999a). As such, the way in which student success is assessed following instruction should also be expanded (Sternberg & Grigorenko, 2004). Sternberg et al. (1998a, 1998b) modeled how to measure elements of successful intelligence in educational settings in a study where a multiple-choice test and multiple performance-based tasks measured students' creative, practical, and analytical learning. This study replicated that approach, as made evident by the instrumentation and method of data collection. Instruments and data collection procedures for this study included the KLSI 3.1 (Kolb, 1999) to determine students' preferred learning styles, a researcher designed criterion-referenced examination, named the AWEA, measuring analytical

skills, wind turbine voltage as a performance-based practical assessment, the same performance-based assessment to measure creativity, and the IMMS to measure motivation (Keller, 2006).

Kolb's Learning Style Inventory 3.1

Kolb's (1999) KLSI 3.1 (see Appendix K; Note: full instrument is not available because of Copyright laws) is one of the most influential and widely distributed instruments used to measure individual learning preference (Kayes, 2005). The KLSI is based on Kolb's (1984) ELT, where learning consists of four constructs – CE, RO, AC, and AE. This instrument includes twelve sentence stems followed by four possible sentence endings. Subjects rank each of the four endings based on their preference for using the four modes. This procedure results in a 48-response instrument that is self-reported and self-scored. A total score was tabulated for each learning mode, and then combined scores for each of the dialectically opposing modes of grasping and transforming (Kolb, 1984) were calculated.

Research has generally supported the internal reliability of the LSI-2, the previous version of the instrument, with Cronbach's alphas ranging from .80 to .87 (Geiger, Boyle, & Pinto, 1993; Loo, 1999b; Willcoxson & Prosser, 1996). Kayes (2005) analyzed the current version, KLSI 3.1, for internal reliability and found Cronbach's alphas ranging from .77 to .82 for each of the four dimensional constructs and .77 to .84 for the grasping and transforming constructs, respectively. In addition, research (Kayes, 2005; Loo, 1999b; Yahya, 1998) has confirmed the internal construct validity of a two-factor

structure proposed originally by Kolb (1984). Thus, it was determined that the KLSI 3.1 was a reliable and valid measure of learning style in this study.

Analytical Wind Energy Assessment

The AWEA, a criterion-referenced test based on the selected educational objectives in the blade design instructional unit, served as the main analytical assessment for the study. The same AWEA, with reorganized answers and questions, was used for both the pre, post, and deferred posttest. The assessment was created as a collaborative effort by the researcher, KidWind® staff and consultants, experts in the field of wind energy engineering, and pedagogical experts in agricultural education. The purpose of the pretest assessment was to capture students' ability to analyze, critique, judge, compare and contrast, evaluate, and assess concepts related to the objectives of the lesson. The AWEA included 40 total questions, of which 30 were multiple-choice questions and 10 were matching questions. The pre-test assessment was utilized for two purposes: (1) to determine that no statistically significant differences in analytical knowledge of blade design content existed prior to the experiment, and (2) as the first of three repeated measures in the SPF-2•3 ANOVA.

Creswell (2008) explained that, “content validity is the extent to which the questions on the instrument and the scores from these questions are representative of all the possible questions that a researcher could ask about the content or skills” (p. 172). Further, Creswell (2008) suggested that researchers should establish both face and content validity on instruments through the review of the assessment by a panel of experts. Experts from KidWind® assessed the AWEA for content validity, suggested

changes, and approved the final set of 40 questions. Suggestions included the deletion of two ambiguous questions, insertion of four discriminating items, three content-related mistakes, and a few typological errors. Pedagogical experts assessed the AWEA for face validity and found it appropriate for secondary agricultural education students.

In addition to issues of validity, reliability refers to the extent that the scores made by an individual remain nearly the same in repeated measurements (Ary, Jacobs, & Razavieh, 2002). Wiersma and Jurs (1990) suggested eight specific methods to increase the reliability of criterion-referenced examination, including homogenous items, discriminating items, enough items, high quality copying and format, clear directions for the students, a controlled setting, motivating introduction, and clear directions for the scorer. Each of these suggestions were considered and addressed carefully in the development of the AWEA.

The role of reliability indices in criterion-reference examinations has been described adequately in the literature (Kane, 1986; Lang, 1982; Popham & Husek, 1969; Wiersma & Jurs, 1990). Although traditional reliability indices based on internal consistency are not relevant, it is an important indication of reliability in criterion-referenced exams (Kane, 1986). Kane (1986) purported that a reliability coefficient less than .50 would not provide reliable results. The Kuder-Richardson 20 (*KR20*) formula (Cronbach, 1970), a test for internal consistency used commonly with criterion-referenced exams, was used to determine reliability of the AWEA. The three AWEA assessments included the same questions and answers. However, the order of questions and answers were altered. The AWEA produced reliability coefficients (*KR20*) for each AWEA, which were as follows: (a) .82 for the pre-test, (b) .90 for the post-test, and (c)

.88 for the deferred post-test. Based on these coefficients, it was determined that the AWEA was a reliable measure of students' analytical knowledge for this study.

Practical Assessment

Sternberg (2002) explained that practical knowledge requires students to apply, use, put into practice, implement, employ, and render practical what they know. The practical assessment used in this study was an authentic assessment that represented the most logical extension of the lesson – to design, build, and test a wind blade model using materials provided by the instructors. Each student was given a universal hub and was asked to create a hub design intended to produce the most voltage possible using a common bank of materials in one hour. Each blade design was attached to a model tower containing a small generator, which was placed in front of a fan set at a constant speed. The voltage output was measured using a voltage meter with a manufacturer noted reliability of $\pm 0.5\%$ reading or ± 2 digits. All variables, aside from the design of the blade, were held constant, and each voltage output was recorded.

Creative Assessment

Creativity is the ability to produce something that is both novel and useful (Sternberg, 1998). In this study, creativity was operationalized as just that – the ability to produce something novel and useful. Based on Guilford's (1950) proposal that creativity could be measured with a psychometric approach, Torrance (1974) developed the Torrance Tests of Creative Thinking (TTCT). This instrument employed a scoring system for fluency, flexibility, originality, and elaboration. Amabile (1996) explained the complex nature of creativity and explained that in light of the many methods for

measurement of creativity, it is important to “specify which domains and elements of creativity are assessed with any particular test” (p. 26). Thus, in this study, originality was measured as the indicator of creativity. The TTCT (Torrance, 1974) operationalized creativity as statistical infrequency, which can be calculated and scored objectively.

The measurement of creativity followed Torrance’s (1974) originality conventions. First, it was important to identify all the ways students could be divergent in their blade design. Students could alter their designs by changing the blade length, blade pitch, blade shape, number of blades, and materials used to make the blades. An additional category of *elaboration* was included for divergent design elements not comprised within the five categories making a sixth element. Two pictures were taken of each blade design created by the participants, and were assessed on the six divergent elements. The purpose of this assessment was to create a frequency of each design element choice, determine a percentage of designs sharing that choice, and create a divergent score for each blade design. Ultimately, a statistical scoring process was utilized to determine how divergent each design was. For example, Table 7 is the scoring data for the number of blades utilized, the frequency of each choice, and the subsequent creativity score given to each design choice. Each participant’s design was scored on the six elements, and those scores were added to achieve the overall creativity score utilized in the analysis. See Appendix N for a full scoring guide that informed the creativity scoring process.

Table 7

Example of Creativity Tabulation and Scoring for Blade Number

Design Element	Frequency	Percentage	Creativity Score
6 Blades	1	1.3%	3
5 Blades	1	1.3%	3
4 Blades	15	18.8%	1
3 Blades	57	71.3%	0
2 Blades	6	7.5%	2

Instructional Materials Motivation Survey

Keller (2006) developed the IMMS (see Appendix L) as a “situational measure of students’ motivation to learn with reference to a specific learning condition” (p. 1). The instrument was designed in correspondence with the ARCS Model (Keller, 1987), based on current literature on human motivation (Keller, 1979, 1984, 1987). “The goal with these instruments is to find out how motivated students are, were, or expect to be, by a particular course” (Keller, 2006, p. 1). The IMMS can be used with adults, college students, and secondary students. The instrument contains 36 statements related to the four conditions that must be met for people to become and remain motivated: (a) attention, (b) relevance, (c) confidence, and (d) satisfaction. Subjects respond using a summated rating scale indicating that each statement is: (1) not true, (2) slightly true, (3) moderately true, (4) mostly true, or (5) very true. The scoring guide (see Appendix L)

indicates which construct each statement measures and notes those statements that are reverse coded.

The instrument can be scored for each of the subscales or added for a total motivation score. Bivariate correlation analysis indicated high correlations between each subscale and the overall motivation score; so, it was decided to use the total motivation score as the indicator of motivation for statistical analysis. The reliability estimates of the attention, relevance, confidence, satisfaction, and total scores, as measured through Chronbach's alpha, were .89, .81, .90, .92, .96, respectively. The internal reliability was determined to be adequate.

Fidelity of Treatment

To reduce experimenter effects (Gay, Mills, Airasian, 2009), and ensure fidelity of the treatment, the researcher was not involved in any of the procedures associated with the experiment. This allowed for active observation of each condition to ensure the appropriate instructional plans and instruments were being delivered with sincerity. Instructional supplements were also retained and reviewed as evidence that each element of the treatment had been delivered.

Analysis of Data

All data were analyzed using Statistical Package for Social Sciences (SPSS[®]), version 20, for Macintosh computers. SPSS[®] was utilized to score each of the instruments as well as conduct the analyses to reduce human error. Using histograms and P – P plots, as suggested by Field (2009), all dependent variables were normally distributed prior to analysis.

Research questions one and two began with an omnibus MANOVA to identify if simple main and main effects were detected. The decision to analyze all five dependent variables in this omnibus MANOVA was theoretical in nature, as outlined by Sternberg's (1999a) theory of successful intelligence. Stevens (2009) noted three assumptions associated with a multivariate approach to testing hypotheses: (a) independence of the observations, (b) multivariate normality on the dependent variables, and (c) equality of the covariance matrices. In reference to the first assumption, careful attention was given to maintaining the individual as the unit of analysis through the design of the experiment. As mentioned above, each dependent variable was checked for normality, as suggested by Field (2009), and was determined to be normally distributed. Finally, the two MANOVA analyses produced insignificant Box's M test of equality of covariance matrices with p values of .10 and .53, respectively, and thus the final assumption is tenable.

Since no simple main effects were found, analyses focused on the main effects. This secondary analysis consisted of two ANOVA analyses for each of the dependent variables. Once again each of the assumptions were tenable as each observation was collected independently, data were normally distributed, and Levene's test for the equality of error variances yielded insignificant p values (see Table 8).

In addition to the post-omnibus ANOVA, a post-omnibus discriminant analysis was employed to provide further explanation of variance using the standardized discriminant function coefficients and the structure matrix. "Discriminant analysis is used to break down the total between association in MANOVA into *additive* pieces,

through the use of uncorrelated linear combinations of the original variables” (Stevens, 2009, p. 245).

Table 8

Summary of p-values for Leven’s Test of Each ANOVA Analysis

Dependent Variable	Analysis by Grasping	Analysis by Transforming
Practical Learning	.32	.08
Analytical Learning	.10	.25
Creative Learning	.99	.27
Motivation for Course	.16	.43

Stevens (2009) noted that discriminant analysis provides the ability to achieve parsimony of description of the variables and provides clarity of interpretation. Only one discriminant function is possible in this study using Steven’s (2009) p and $(k - 1)$ rule, as only two groups are present in the study.

Research question three was answered using a SPF-2•3 repeated measure MANOVA. Stevens (2009) shared that repeated measures “are the natural design to use when the concern is with performance trends over time” (p. 413). As stated earlier, the assumptions of normality and independence of observations were met. Mauchly’s test of sphericity produced a p value of .30, making the assumption tenable. Since no simple main effects were found, attention turned to the main effects using univariate analysis of variance. Levene’s test produced p values of .13, .07, and .96 for the pre-, post-, and deferred post-tests, respectively.

Methods for Determining Effect Size

Though a statistically significant difference may be found, it is always important to consider the practical effect of a treatment condition (Kirk, 1995). Stevens (2009) explained that the practical effect, sometimes called the effect size, is a measure of practical differences that can be compared to other studies regardless of the sample size. Practical effect is inherent in the multivariate analyses as Wilk's lambda is a statistical representation of the unexplained variance. As such, one minus Wilk's lambda is the variance explained by the treatment of interest, and is thus an effect size. For the univariate analyses, partial eta squared is the reported effect measure in this study. Cohen (1977) characterized $\eta_p^2 = .01$ as small, $\eta_p^2 = .06$ as medium, and $\eta_p^2 = .14$ as a large effect size. These standards will be utilized in the analysis of practical effect for univariate analyses. Though these standards are helpful, Light, Singer, and Willett (1990) reminded those interpreting effect sizes to remember that, "because practical significance depends upon the research context, only you can judge if an effect is large enough to be important" (p. 195).

Controlling Threats to Valid Inference Making

Two goals of research are to draw valid conclusions about the effects of an independent variable and to make valid generalizations to populations and settings of interest (Kirk, 1995). Campbell and Stanley (1966) identified four categories of threats to that aim: (a) statistical conclusion validity, (b) internal validity, (c) construct validity of causes and effects, and (d) external validity. Steps taken to mitigate each of these threats will be addressed.

Statistical Conclusion Validity

Statistical power is defined as “the probability of rejecting the null hypothesis when it is false” (Stevens, 2009, p. 162). The power of any statistical test depends on (a) the alpha level set by the experimenter, (b) sample size, and (c) effect size. Stevens (2009) suggested both *a priori* and post hoc power analyses should be considered seriously when conducting experiments. In the design of the study, G*Power Version 3.1 (Faul, Erdfelder, Lang, & Buchner, 2007) was utilized to determine the estimated sample size needed to achieve at least a power of .80, with an effect size of .30 and an alpha level of .05. The software program estimated a necessary sample size for both groups of 46 for the CRF-22 MANOVA design and 32 for the SPF-2•3 repeated measure ANOVA. Thus, an initial sample of 120 participants was sought. Post hoc analysis of power is provided in the findings section using IBM® SPSS® Statistics power analysis. Stevens (2009) explained that this post hoc estimation of power is important in terms of how an individual interprets the results of completed studies.

In addition to power, each of the assumptions required for the statistical tests were tested for and met to insure that inferences were made correctly. Statistical tests were identified *a priori* that answered the research questions logically. To reduce error, measures utilized to capture the key variables were chosen and analyzed carefully for both validity and reliability to reduce error. This experimental design employed a clinical approach in the overall design to standardize the administration of treatment levels so as not to inflate the estimate of error variance resulting in failures to reject null hypotheses. This clinical administration reduced random irrelevancies in the experimental setting, which also reduced the estimate of error variance. Finally, randomization of subjects to

treatment and comparison groups reduced the chance of idiosyncratic characteristics of the subjects, and thus reduced error variance.

Threats to Internal, External, and Construct Validity

Behavioral research involves the measurement of very complex constructs (Ary et al., 2002). Though “true experimental designs control for nearly all threats to internal and external validity” (Gay, Mill, & Airasian, 2009, p. 255), careful attention was given to validity in design of the experiment. Threats to internal validity included history, maturation, testing, instrumentation, statistical regression, selection, mortality, interactions with selection, ambiguity about the direction of causal influence, diffusion or imitation of treatments, compensatory rivalry by respondents receiving less desirable treatments, and resentful demoralization of respondents receiving less desirable treatments. The clinical nature of the study controlled for all threats but testing effect and mortality. Testing effect was controlled for by creating various versions of the analytical measurement, which was the only instrument used more than once. The only issue related to mortality involved the six-week deferred post-test, where only 90% of the respondents completed the final analytical observation.

Threats to external validity include interaction of testing and treatment, interaction of selection and treatment, interaction of setting and treatment, interaction of history and treatment, reactive arrangements, and multiple-treatment interference (Kirk, 1995). As mentioned above, the clinical nature of the study controlled for each of the threats to external validity. However, a few noted limitations should be discussed in reference to extending these results to other settings. First, the study was restricted to a

sample of students that was willing to participate in the full-day experiment. This may have caused some restriction in those sampled, resulting in limited generalizability. Though the clinical nature of the experiment stood as a “gold standard” (Stevens, 2009, p. 40) of control, “experiments are usually performed in an environment that permits a high degree of control of nuisance variables. Such environments rarely duplicate real-life situations” (Kirk, 1995, p. 6). Finally, students were made aware of the goals and aims of the study, in accordance with IRB requirements, and this could have limited control of reactive arrangements.

Summary

The purpose of this study was to determine the effects of experiential learning on secondary agricultural education students’ successful intelligence. The study was framed by three research questions:

1. What interactions exist between student learning styles, students’ successful intelligence, and chosen instructional approach?
2. What differences exist in students’ successful intelligence and motivation for the course between experiential learning and direct instruction approaches?
3. Do the analytical effects achieved by experiential and direct instructional approaches persist over time?

This chapter presented the research design, described the population and sample, discussed the procedures of the experiment, explained the instrumentation and data analysis process, and concluded with a discussion of the control of threats to valid

inference making. Chapter IV will present the findings associated with each of the research questions and will address each of the research hypotheses.

CHAPTER IV

FINDINGS

Agricultural education has subscribed to an experiential (Kolb, 1984) approach from the early 1900's to the present (Baker et al., 2012; Knoblock, 2003; Roberts, 2006). However, a paucity of research exists that explores the effects of experiential learning, experimentally (Kirschner et al., 2006). As such, the purpose of this study was to address this gap in the literature to plan and support instruction in secondary agricultural education programs more effectively. Sternberg (1999a) suggested a more appropriate measurement framework that assesses successful intelligence. Successful intelligence addresses students' practical, creative, and analytical learning, as well as student motivation. These components of successful intelligence served as the four dependent variables of the study; the approach to learning was the key independent variable. Learning style was also considered in the analysis to provide insight into the role that learning preferences play when choosing an instructional approach. Therefore, the study's treatment was an experiential curriculum compared to the commonly used method of direct instruction – somewhat polar opposite approaches.

The study was framed by three research questions:

1. What interactions exist between students' preferred learning styles, successful intelligence, and the instructional approach chosen?
2. What statistically significant differences exist in students' successful intelligence and motivation for the course between experiential learning and direct instruction approaches?
3. Do the analytical effects achieved by experiential and direct instructional approaches persist over time?

As is the convention for statistical analysis, null hypotheses were developed for each of the three research questions. Two, CRF – 22 MANOVA's were utilized to answer research questions one and two, and one SPF-2•3 was utilized to answer research question three. An alpha level of .05 was determined a priori.

Research Question One:

H₀ 1: There is no interaction between learning style, as defined by two modes of transforming information, students' successful intelligence measures, and students' motivation for the course.

H₀ 2: There is no interaction between learning style, as defined by two modes of grasping information, students' successful intelligence measures, and students' motivation for the course.

Research Question Two:

H₀ 3: There is no difference in students' successful intelligence measures and motivation for the course between the experiential learning and direct instruction approaches to learning.

Research Question Three:

H₀ 4: There is no difference in the pre-test, post-test, and deferred post-test scores for students taught with the experiential approach.

H₀ 5: There is no difference in the pre-test, post-test, and deferred post-test scores for students taught with the direct instruction approach.

Chapter I provided an overview of the study including the need, purpose, research questions, definitions, assumptions, and limitations. Chapter II provided an in-depth review of the literature related to the theoretical framework, Kolb's (1984) experiential learning theory, as well as other key variables of the study. Chapter III addressed the methodology employed in answering each of the research questions, and included a multivariate (Stevens, 2009) experimental (Kirk, 1995) design seeking to be as clinical as possible when conducting quantitative research in behavioral settings.

Findings

The findings will begin with data providing statistical context to the main analyses, and then will address each research question independently.

Correlations of Variables

Prior to conducting the main analysis of the study utilizing inferential statistics, the correlation of the dependent variables were analyzed (Miller, 1998). Statistically

significant correlations ($p < .05$) were found between the creativity and practical measures ($r = .26$), and the practical and motivation measures ($r = .21$). Statistically significant correlations ($p < .01$) were found between analytical and motivation measures ($r = .41$), and the analytical and retention measures ($r = .54$), which were expected as they are repeated measures of the same assessment. See table 9 for the summary of all correlations.

Table 9

Summary of Correlations Between Creative, Practical, Analytical, Motivation, and Retention Measures

	1	2	3	4	5
1. Creativity	---	.26*	-.17	.05	.01
2. Practical		---	.15	.21*	-.03
3. Analytical			---	.41**	.54**
4. Motivation				---	.41**
5. Retention					---

* $p < .05$; ** $p < .01$

Significant Differences in Analytical Skills Prior to Treatment

Prior to the conduction of the study, the pre-test was administered as both one of three repeated measures and a pre-test assessment of pre-existing differences in analytical content knowledge related to blade design. Table 10 presents the findings of a one-way ANOVA that found no statistically significant differences in the analytical knowledge of blade design prior the experiment, $F(1, 78) = 1.28$, $p = .26$. Thus, it was assumed that the groups were similar in analytical blade design knowledge entering the experiment.

Table 10

Comparison of Pre-Test Analytical Scores: An ANOVA Summary Table

Source of Variance	<i>SS</i>	<i>df</i>	<i>MS</i>	<i>F</i>	<i>p</i>
Group	62.11	1	62.11	1.28	.26
Error	3795.10	78	48.66		
Total	3857.2	79			

Means and Standard Deviations for Treatment and Control Groups

The means and standard deviations are relevant to the answering of each of the research questions, and thus, will be presented first. The means and standard deviations (in parentheses) for each of the dependent variables will be presented for both conditions. In addition, note that analysis is by both grasping and transforming learning style distinctions.

The mean creativity scores are presented in Table 11. The creativity scores were based on the TTCT (Torrance, 1974) and ranged from 1 to 15, indicating the originality of the blade design. The experiential learning treatment group means (with standard deviations in parenthesis) were 6.04 (3.01) for a learning preference of grasping via apprehension, 6.67 (3.92) for a learning preference of grasping via comprehension, 6.33 (3.09) for a learning preference of transforming via extension, and 6.07 (3.71) for a learning preference of transforming via intention. The direct instruction comparison group means were 3.68 (2.02) for a learning preference of grasping via apprehension, 3.91 (2.81) for a learning preference of grasping via comprehension, 3.69 (2.27) for a learning preference of transforming via extension, and 3.85 (2.19) for a learning preference of transforming via intention.

Table 11

Creative Score Means and Standard Deviations

		Experiential Learning		Direct Instruction	
		<i>n</i>	<i>M (SD)</i>	<i>n</i>	<i>M (SD)</i>
Grasping via	Apprehension	26	6.04 (3.01)	31	3.68 (2.02)
	Comprehension	12	6.67 (3.92)	11	3.91 (2.81)
Transforming via	Extension	24	6.33 (3.09)	29	3.69 (2.27)
	Intention	14	6.07 (3.71)	13	3.85 (2.19)
Treatment	Total	38	6.24 (3.28)	42	3.74 (2.20)

Practical scores reflected the voltage output, as measured by a voltmeter produced from wind turbines designed by students. Results are shown in Table 12. Voltages ranged from .00, which indicated a blade design that did not rotate at all, to 1.89, which indicated 1.89 volts were produced by the rotation of the blade design. The experiential learning treatment group means were .85 (.43) for a learning preference of grasping via apprehension, .67 (.42) for a learning preference of grasping via comprehension, .83 (.37) for a learning preference of transforming via extension, and .72 (.54) for a learning preference of transforming via intention. The direct instruction comparison group means were .41 (.30) for a learning preference of grasping via apprehension, .39 (.30) for a learning preference of grasping via comprehension, .36 (.27) for a learning preference of transforming via extension, and .51 (.33) for a learning preference of transforming via intention.

Table 12

Practical Score Means and Standard Deviations

		Experiential Learning		Direct Instruction	
		<i>n</i>	<i>M (SD)</i>	<i>n</i>	<i>M (SD)</i>
Grasping via	Apprehension	26	.85 (.43)	31	.41 (.30)
	Comprehension	12	.67 (.42)	11	.39 (.30)
Transforming via	Extension	24	.83 (.37)	29	.36 (.27)
	Intention	14	.72 (.54)	13	.51 (.33)
Treatment	Total	38	.79 (.44)	42	.41 (.29)

All analytical scores, including each of the repeated measures, utilized the AWEA criterion-referenced exam, built around the blade design learning objectives (see Table 13). The test included forty multiple choice and matching questions that added to a total possible score of 40. The scores ranged from 4 to 32 points coordinating with a typical school grade of 10% and 80%, respectively. The experiential learning treatment group means were 15.35 (5.59) for a learning preference of grasping via apprehension, 15.75 (6.94) for a learning preference of grasping via comprehension, 15.67 (5.15) for a learning preference of transforming via extension, 15.14 (7.35) for a learning preference of transforming via intention. The direct instruction comparison group means were 16.55 (7.32) for a learning preference of grasping via apprehension, 19.18 (9.04) for a learning preference of grasping via comprehension, 17.45 (7.94) for a learning preference of transforming via extension, and 16.77 (7.72) for a learning preference of transforming via intention.

Table 13

Analytical Pre-Test Means and Standard Deviations

		Experiential Learning		Direct Instruction	
		<i>n</i>	<i>M (SD)</i>	<i>n</i>	<i>M (SD)</i>
Grasping via	Apprehension	26	15.35 (5.59)	31	16.55 (7.32)
	Comprehension	12	15.75 (6.94)	11	19.18 (9.04)
Transforming via	Extension	24	15.67 (5.15)	29	17.45 (7.94)
	Intention	14	15.14 (7.35)	13	16.77 (7.72)
Treatment	Total	38	15.47 (5.96)	42	17.24 (7.78)

Analytical post-test scores (see Table 14) were assessed using the same AWEA criterion-referenced exam as the pre-test with slight question and response order changes. The test included forty multiple choice and matching questions that added to a total possible score of 40. The scores ranged from 7 to 37 points, coordinating with a typical school grade of 18% and 93% respectively. The experiential learning treatment group means were 24.15 (7.80) for a learning preference of grasping via apprehension, 25.42 (9.89) for a learning preference of grasping via comprehension, 26.75 (8.35) for a learning preference of transforming via extension, and 20.79 (7.29) for a learning preference of transforming via intention. The direct instruction comparison group means were 29.07 (6.30) for a learning preference of grasping via apprehension, 29.18 (8.32) for a learning preference of grasping via comprehension, 28.69 (7.47) for a learning preference of transforming via extension, and 30.00 (7.87) for a learning preference of transforming via intention.

Table 14

Analytical Post-Test Score Means and Standard Deviations

		Experiential Learning		Direct Instruction	
		<i>n</i>	<i>M (SD)</i>	<i>n</i>	<i>M (SD)</i>
Grasping via	Apprehension	26	24.15 (7.80)	31	29.07 (6.30)
	Comprehension	12	25.42 (9.89)	11	29.18 (8.32)
Transforming via	Extension	24	26.75 (8.35)	29	28.69 (7.47)
	Intention	14	20.79 (7.29)	13	30.00 (7.87)
Treatment	Total	38	24.55 (8.40)	42	29.10 (6.76)

Analytical deferred post-test scores (see Table 15) ranged from 6 to 34 points, coordinating with a typical school grade of 15% and 85%, respectively. The experiential learning treatment group means were 17.12 (8.82) for a learning preference of grasping via apprehension, 20.00 (7.07) for a learning preference of grasping via comprehension, 18.00 (8.19) for a learning preference of transforming via extension, and 18.11 (8.89) for a learning preference of transforming via intention. The direct instruction comparison group means were 17.57 (8.53) for a learning preference of grasping via apprehension, 22.20 (7.66) for a learning preference of grasping via comprehension, 18.85 (10.58) for a learning preference of transforming via extension, and 18.64 (7.15) for a learning preference of transforming via intention.

Table 15

Analytical Deferred Post-Test Score Means and Standard Deviations

		Experiential Learning		Direct Instruction	
		<i>n</i>	<i>M (SD)</i>	<i>n</i>	<i>M (SD)</i>
Grasping via	Apprehension	17	17.12 (8.82)	28	17.57 (8.53)
	Comprehension	8	20.00 (7.07)	10	22.20 (7.66)
Transforming via	Extension	16	18.00 (8.19)	27	18.85 (10.58)
	Intention	9	18.11 (8.89)	11	18.64 (7.15)
Treatment	Total	25	18.04 (8.26)	38	18.79 (8.46)

Motivation scores were calculated as the total IMMS score, which is the sum of the ARCS indicators, and are shown in Table 16. Motivation scores ranged from 81.00 to 163.00. The experiential learning treatment group means were 126.65 (16.67) for a learning preference of grasping via apprehension, 127.08 (17.67) for a learning preference of grasping via comprehension, 131.50 (15.41) for a learning preference of transforming via extension, and 118.71 (16.35) for a learning preference of transforming via intention. The direct instruction comparison group means were 124.81 (17.79) for a learning preference of grasping via apprehension, 126.55 (18.67) for a learning preference of grasping via comprehension, 125.62 (15.73) for a learning preference of transforming via extension, and 124.46 (22.49) for a learning preference of transforming via intention.

Table 16

Motivation Score Means and Standard Deviations

		Experiential Learning		Direct Instruction	
		<i>n</i>	<i>M (SD)</i>	<i>n</i>	<i>M (SD)</i>
Grasping via	Apprehension	26	126.65 (16.67)	31	124.81 (17.79)
	Comprehension	12	127.08 (17.67)	11	126.55 (18.67)
Transforming via	Extension	24	131.50 (15.41)	29	125.62 (15.73)
	Intention	14	118.71 (16.35)	13	124.46 (22.49)
Treatment	Total	38	126.79 (16.75)	42	125.26 (17.81)

Findings Associated with Research Question One

Research question one sought to determine what interactions existed between students' learning styles, successful intelligence, and the chosen instructional approach. An omnibus multivariate analysis of variance was utilized to address these two null hypotheses and is presented in Table 17.

Table 17

Summary of Two MANOVA Analyses Testing for Both Simple Main and Main Effects of the Treatment Conditions by Learning Style (df= 73)

Source of Variance	Λ	F	p	Power
Group x Transforming	.93	.96	.44	.41
Group x Grasping	.98	.30	.87	.11
Group				
Transforming	.63	10.95	.00	1.00
Grasping	.66	9.55	.00	.99

Using Wilk's statistics, there were no statistically significant simple main effects between the treatment group and the transformation learning style, $\Lambda = .93$, $F(3,76) = .96$, $p = .44$. Viewing the simple main effects from the grasping learning style distinction, non-significant interactions were also found $\Lambda = .98$, $F(3,76) = .30$, $p = .87$. The power of these tests is included in Table 17. As described in Chapter III, Kolb's (1984) learning style inventory maintains a two-factor ipsative structure (Kayes, 2005), and thus, this analysis of learning style in the two factor structure demonstrated no statistically significant simple main effects, or interaction, between learning styles and

the experimental conditions regarding measures of successful intelligence. Pursuant to these findings, both null hypothesis one and two failed to be rejected, and attention of the analysis moved to the main effects associated with research question two.

Findings Associated with Research Question Two:

Once it was determined there were no simple main effects, attention turned to the testing of main effects. In response to no interactions by learning style, data were collapsed into one analysis. Research question two sought to determine what differences existed in students' successful intelligence and motivation for the course between experiential learning and direct instruction approaches. Once again, the omnibus MANOVA looked at main effects from a grasping and transforming learning style perspective and found statistically significant differences in both (see Table 17).

In the transforming distinction, Wilk's statistic yielded a statistically significant effect between students' successful intelligence measures and motivation for the course involved in the two treatment conditions, $\Lambda = .63$, $F(3,76) = 10.95$, $p = .00$. It is important to note that Wilk's lambda is an index of how variability in the dependent variables is attributable to regression, and thus, is inherently a measure of effect size (Stevens, 2009). In this case, 37% of the variance was accounted for by the dependent variables. Regarding the grasping analysis, the Wilk's statistic yielded statistically significant effects between the two treatment conditions $\Lambda = .66$, $F(3,76) = 9.55$, $p = .00$ explaining 34% of the variance in the dependent variables. When juxtaposed to the transform analysis, this finding provided a procedural check and confirmation of the statistically significant main effects due to the varying approaches to instruction. Based

on these findings, null hypothesis three was rejected, and it was determined that there were statistically significant differences in successful intelligence and motivation measures of students involved in experiential learning and direct instruction treatments.

Once statistically significant differences were found in the omnibus analysis, post hoc procedures were utilized to explore the nature of the differences. Field (2009) recommended following any multivariate analysis of variance with both univariate tests and discriminant analysis to understand fully the nature of the differences. Discriminant analysis further deconstructs the total between associations into additive pieces and produces a structure matrix that purports uncorrelated linear combinations of the dependent variables (Stevens, 2009). Analysis of the standardized discriminant coefficients are also shared but will be ignored, as the correlations were made apparent in Table 9. Table 18 presents a summary of the two post-omnibus procedures including univariate analysis of variance for each dependent variable and the discriminant analysis.

Table 18

Summary of Univariate Analysis of Variance and Discriminant Analysis, Including Creative, Practical, Analytical, and Motivation Measures

Variable	<i>F</i>	<i>p</i>	Standardized Canonical Discriminant Function Coefficients	Structure Matrix
Creativity	16.17	.00	.49	.55
Practical	21.97	.00	.78	.64
Analytical	7.16	.01	-.60	-.37
Motivation	.16	.70	.13	.05

The univariate analysis yielded statistically significant differences between treatment groups for three of the four dependent variables (see Table 18). Experiential learning mean scores (with standard deviations in parenthesis) for creativity, practical, analytical, and motivation measures by treatment (see Tables 11-16) were 6.24 (3.28), .79 (.44), 24.55 (8.40), and 126.79 (16.75), respectively. Direct instruction mean scores (see Tables 11-16) (with standard deviations in parenthesis) for creativity, practical, analytical, and motivation measures by treatment were 3.74 (2.20), .41 (.29), 29.10 (6.76), and 125.26 (17.81), respectively. There was a significant statistical and large practical effect of experiential learning on levels of creativity, $F(1,78) = 16.17, p = .00, \eta_p^2 = .17$, with a power of .98. There was also a significant statistical and large practical effect of experiential learning on practical skills, $F(1,78) = 21.97, p = .00, \eta_p^2 = .22$, with a power of 1.00. In contrast, there was a statistically significant difference with a medium practical effect of direct instruction on analytical skills, $F(1,78) = 7.16, p = .01, \eta_p^2 = .08$, with a power of .75. However, no effect was found for motivation scores, $F(1,78) = .16, p = .70$, with a power of .07.

The discriminant analysis (see Table 18) revealed one statistically significant discriminant function, $\Lambda = .59, \chi^2(4) = 39.65, p = .00, \text{canonical } R^2 = .64$, as expected with two treatment conditions. The discriminant function revealed that creativity ($r = .55$) and practical skills ($r = .64$) loaded positively on the function, while analytical skills ($r = -.60$) loaded negatively on the function. This analysis of the structure matrix further confirms the univariate analysis of variance in identifying that creativity and practical skills discriminated experiential learning from direct instruction, and analytical skills defined the direct instruction approach.

Findings Associated with Research Question Three

Research question three sought to examine if analytical effects achieved by experiential and direct instructional approaches persisted over time. The MANOVA (see Table 19) for the repeated measure design indicated that there were no statistically significant simple main effects, $\Lambda = .98$, $F(2,60) = .56$, $p = .58$. Attention then turned to main effects of which statistically significant differences were found, $\Lambda = .25$, $F(3,76) = 88.13$, $p = .00$. The power of these analyses is noted in Table 19. The next step in the analysis sought to understand better the nature of the detected differences.

Table 19

Summary of MANOVA Analyses Testing for Both Simple Main and Main Effects of the Deferred Analytical Repeated Measures (df = 60)

Source of Variance	Λ	F	p	Power
Time x Group	.98	.56	.58	.02
Time	.25	88.13	.00	.75

Contrasts (see Table 20) revealed that there were statistically significant differences between the three repeated analytical measures, $F(2,122) = 86.01$, $p = .00$, $\eta_p^2 = .59$, with a large practical effect. Table 21 further clarified those differences in identifying statistically significant differences between the pre and post-test, $F(1,61) = 172.84$, $p = .00$, $\eta_p^2 = .74$, as well as a statistically significant difference between the post and deferred-post tests, $F(1,61) = 87.36$, $p = .00$, $\eta_p^2 = .59$. Both of these contrast also produced strong practical effects, as indicated by measure of effect. These finding are presented visually in Figure 16. The graph of repeated measures also depicts the finding

that there were no statistically significant differences between analytical scores for the two treatments over time, $F(1,61) = .68, p = .41$. As such, both null hypothesis four and five were rejected, which indicated there were statistically significant differences between the three repeated measures of both experiential learning and direct instruction approaches.

Table 20

Comparative Analysis of Student Analytical Knowledge by Treatment Group: A Split-Plot Factorial 2.3 Repeated Measures ANOVA Summary Table (n = 63)

Source of Variance	<i>SS</i>	<i>df</i>	<i>MS</i>	<i>F</i>	<i>p</i>	η_p^2
Repeated Measure Effects						
Time	4086.63	2	2043.32	86.01	.00	.59
Error	2898.47	122	23.76			
Between Subjects Effects						
Group	31.33	1	31.33	.68	.41	.01
Error	2826.22	61	46.33			

Table 21

Repeated Measure Analytical Repeated Design Within-Subjects Contrasts

Source of Variance	<i>SS</i>	<i>df</i>	<i>MS</i>	<i>F</i>	<i>p</i>	η_p^2
Time						
Level 1 vs. Level 2	7108.30	1	7108.30	172.84	.00	.74
Level 2 vs. Level 3	4958.56	1	4958.56	87.36	.00	.59
Error						
Level 1 vs. Level 2	2508.68	61	41.13			
Level 2 vs. Level 3	3462.334	61	56.76			

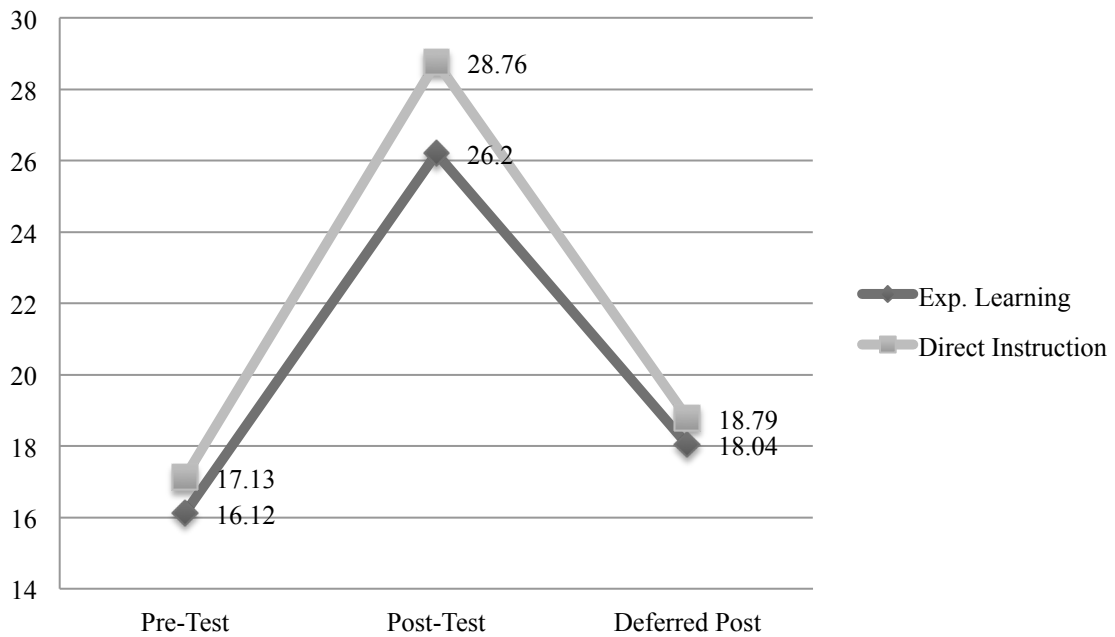

Figure 16. Graph of Repeated Measure Analytical Scores

Summary

Chapter IV has provided an overview of the findings for each research question inherent to this study. The following findings were discussed:

- In response to research question one, no simple main effects were present, indicating that there is no interaction between learning style, students' successful intelligence measures, and treatment condition.
- In response to research question two, it was found that there were statistically significant differences as a result of experiential based instruction. Creative and practical scores were significantly greater in the experiential treatment, while the direct instruction approach led to statistically significant gains in analytical scores. There were no statistically significant differences between the treatment conditions and motivation for the course.
- In response to research question three, it was found that the analytical gains achieved by both treatments did not persist six weeks after instruction.

Chapter V will extrapolate these findings further by drawing conclusions based on the analyses, making recommendations, and discussing implications.

CHAPTER V

SUMMARY, CONCLUSIONS, IMPLICATIONS, RECOMMENDATIONS, AND DISCUSSION

The current methods of secondary education are simply not preparing students for careers and/or college (NASSP, 1996, 2004; SCANS, 2001; Van Driel, Beijaard, & Verloop, 2001). Agricultural education has been called to contribute to the development of core academic skills through STEM integration (NRC, 1988) while also remaining true to the vocational mission (Roberts & Ball, 2006). Experiential learning is discussed as the method chosen by agricultural education to accomplish that challenge, but there is little to no evidence that the pedagogy explained by Kolb (1984) is effective in producing academic, practical, creative, and motivational products (Kirschner et al., 2006). In response to this need, the study purposed to determine the effects of experiential learning, when compared to the traditional direct instruction method, on students' successful intelligence (Sternberg, 1999a) and motivation for learning course content.

The study was framed by three research questions:

1. What interactions exist between students' preferred learning styles, successful intelligence, and the instructional approach chosen?
2. What statistically significant differences exist in students' successful intelligence and motivation for the course between experiential learning and direct instruction approaches?
3. Do the analytical effects achieved by experiential and direct instructional approaches persist over time?

As is the convention for statistical analysis, null hypotheses were developed for each of the three research questions.

Research Question One:

H₀ 1: There is no interaction between learning style, as defined by two modes of transforming information, on students' successful intelligence measures and motivation for the course.

H₀ 2: There is no interaction between learning style, as defined by two modes of grasping information, on students' successful intelligence measures and motivation for the course.

Research Question Two:

H₀ 3: There is no difference in students' successful intelligence measures and motivation for the course between the experiential learning and direct instruction approaches to learning.

Research Question Three:

H₀ 4: There is no difference in the pre-test, post-test, and deferred post-test scores for students taught with the experiential approach.

H₀ 5: There is no difference in the pre-test, post-test, and deferred post-test scores for students taught with the direct instruction approach.

Chapter I provided an overview of the need for the study, research questions, definitions, and the population of interest. Chapter II expanded the description of literature related to experiential learning and the variables of interest in this study. Chapter III outlined the methods employed to answer the research questions. Chapter IV presented the findings of the study. Chapter V provides the final summary of conclusions, recommendations, implications, and discussions of the findings. A brief overview of the design, methods, and findings will also be provided to set the context for the conclusions.

Methods

The design of the study was experimental and utilized CRF-2.2 MANOVA's to answer research questions one and two, and a SPF-2.3 MANOVA repeated measure to answer research question three. The multivariate design, including dependent variables based on Sternberg's (1999a) theory of successful intelligence, was chosen purposefully to examine the complicated and multi-dimensional nature of educational interventions (Stevens, 2009). Independent variables included the instruction approach, experiential learning and direct instruction, and Kolb's (1984) learning style operationalized within

the two-factor framework of dialectically opposed ways of grasping and transforming experiences.

All students enrolled ($N = 120$) in the chosen secondary agricultural education program served as the population of interest for the study. Stratified random sampling (Gay et al., 2009) was utilized to ensure comparisons between the learning style stratas present in the sample that were statistically powerful. A sample of 80 participants were secured and randomly assigned to each of the two treatment conditions. The experiential learning treatment included a four-hour curriculum built around the four modes of learning – CE, RO, AC, and AE. The comparison group followed a four-hour scripted direct instruction lesson plan that included instruction of the content, multiple practice opportunities, and constant reinforcements for mastery of the content. Both curriculums followed KidWind's® objectives for blade design, which included STEM and natural resource content objectives. KidWind® consultants assisted in connecting the pre-existing curriculum to the approaches of the two instructional approaches.

Measurement of the students' analytical knowledge, for both the CRF – 22 and the SPF-2•3 repeated measure design, was a 40 question criterion-referenced exam. This measure included thirty multiple-choice questions and 10 matching options. Each student planned for and built a wind turbine utilizing their chosen blade design. These authentic products were utilized to assess both students' practical and creative skills. Utilizing pictures of the blade designs, creativity was defined as numerical originality, and was measured utilizing a system similar to that of Torrance's (1974) Test of Creative Thinking. Practical skills were measured through the measurement of the actual voltage output produced by each wind turbine – an authentic assessment of the practical

application of the instruction. Motivation was measured using Keller's (2006) IMMS assessment, which provided an overall score depicting students' motivation for the course. Finally, student learning styles were determined using Kolb's (1999) Learning Style Inventory 3.1, which is in line with the theoretical framework of the study.

All data were analyzed using Statistical Package for Social Sciences (SPSS[®]) version 20 for Macintosh computers. SPSS[®] was utilized to score each of the instruments as well as conduct the analyses to reduce human error. A CRF-2.2 MANOVA was utilized in the analysis of research questions one and two, and a SPF-2.3 MANOVA repeated measure provided analysis for research question three. All assumptions of the analyses were tested and held as tenable.

Summary of Findings

Findings were summarized by research question. The means and standard deviations for each treatment condition are summarized in Table 2 to provide statistical context to the summary of findings and conclusions.

Research Question One

Research question one examined what interactions exist between students' learning styles, successful intelligence, and chosen instructional approach. The CRF-22 MANOVA indicated no simple main effects were present for both the transforming and grasping delineation of learning style, $\Lambda = .93$, $F(3,76) = .96$, $p = .44$, and $\Lambda = .98$, $F(3,76) = .30$, $p = .87$. Thus, null hypothesis one and two failed to be rejected, and attention of the analysis moved to the main effects of interest in research question two.

Table 22

Summary of Means and Standard Deviations for Each Experimental Condition

Dependent Variable	Experiential Learning		Direct Instruction	
	<i>n</i>	<i>M (SD)</i>	<i>n</i>	<i>M (SD)</i>
Creativity	38	6.24 (3.28)	42	3.74 (2.22)
Practical Skills	38	.79 (.44)	42	.41 (.29)
Pre-Test Analytical Skills	38	15.47 (5.96)	42	17.24 (7.78)
Post-Test Analytical Skills	38	24.55 (8.40)	42	29.10 (6.76)
Deferred Post Analytical Skills	25	18.04 (8.26)	38	18.79 (8.46)
Motivation	38	126.79 (16.75)	42	125.26 (17.81)

Research Question Two

Research question two examined what differences existed in students' successful intelligence and motivation for the course between experiential learning and direct instruction approaches. The CRF-22 MANOVA did produce statistically significant main effects for both the transforming and grasping learning style analyses, $\Lambda = .63$, $F(3,76) = 10.95$, $p = .00$, and $\Lambda = .66$, $F(3,76) = 9.55$, $p = .00$. The Wilk's lambda indicated that 34% to 37% of the variance in the dependent variables was attributable to the treatment. Analysis by learning style was collapsed because there were no statistically significant interactions, and the variance by treatment was of primary interest.

Post-omnibus contrasts explored the nature of these differences. Students in the experiential learning group scored significantly higher in creativity measures than those in the direct instruction comparison group, $F(1,78) = 16.17, p = .00, \eta_p^2 = .17$. Those in the experiential learning treatment also scored significantly better in practical measures, $F(1,78) = 21.97, p = .00, \eta_p^2 = .22$. The direct instruction group scored significantly better on the analytical measure, $F(1,78) = 7.16, p = .01, \eta_p^2 = .08$, noting only a medium practical effect. Finally, there were no statistically significant differences in the motivation scores for the course when comparing treatment and control groups. A discriminant analysis revealed one statistically significant function, $\Lambda = .59, \chi^2(4) = 39.65, p = .00, \text{canonical } R^2 = .64$. This analysis confirmed the findings of the univariate contrasts in explaining that creativity ($r = .55$) and practical skills ($r = .64$) loaded positively on the function while analytical skills ($r = -.60$) loaded negatively and motivation had a negligible contribution to the function ($r = .13$).

Based on the reported findings, it was determined there were statistically significant differences of measures of successful intelligence and student motivation between those who were taught experientially and those who were taught through direct instruction. Thus, null hypothesis three failed to be accepted.

Research Question Three

Research question three explored if the analytical effects achieved by experiential and direct instructional approaches persisted over time. A SPSS-2.3 MANOVA repeated measure found no statistically significant simple main effects, turning attention to the main effects, $\Lambda = .98, F(2,60) = .56, p = .58$. However, the omnibus analysis did produce

statistically significant main effects, $\Lambda = .25$, $F(3,76) = 88.13$, $p = .00$, indicating there were differences between the repeated measure scores. Between factor contrasts confirmed that the analytical scores did not vary differently by treatment, $F(1,61) = .68$, $p = .41$, but that statistically significant differences were found between the repeated measures, $F(2,122) = 86.01$, $p = .00$, $\eta_p^2 = .59$. More specifically, pre-test and post-test analytical scores differed, $F(1,61) = 172.84$, $p = .00$, $\eta_p^2 = .74$, and post-test and deferred post-test analytical scores differed, $F(1,61) = 87.36$, $p = .00$, $\eta_p^2 = .59$. These statistics indicated that students' analytical knowledge began low, increased significantly, and then declined significantly, over time. Following these analyses, both null hypotheses four and five failed to be accepted.

Conclusions

Based on the findings of the study, and realizing the limitations of the sample and population, six conclusions were made. Each of the conclusions listed are discussed further in the following section.

1. When taught either through experiential learning or direct instruction, students' analytical, creative, and practical performance, as well as motivation for the course, was not affected by student learning style.
2. Students who were taught experientially had higher creativity scores when compared to those who were taught through direct instruction.
3. Students who were taught experientially had higher practical scores when compared to those who were taught through direct instruction.

4. Students who were taught experientially had lower analytical scores when compared to those who were taught through direct instruction.
5. Experiential learning and direct instruction approaches to learning produce similar student motivation outcomes.
6. Students who were taught both experientially and through direct instruction experienced a statistically significant increase in analytical scores, but that increase was followed by a statistically significant decrease in analytical scores six weeks following instruction.

Discussion and Implications

Before presenting the discussion and implications of the noted conclusions, it is important to speak to the nature of experiential learning as operationalized in this study. Brookes (2002) stated an important point when discussing experiential learning when he shared that, “Realism and individualism are convenient; they exempt...educators from having to know much about nature (it can be perceived directly) or culture (since meaning comes from within the individual rather than from collective memory)” (p. 415). It is important for educators to move past “the fuzzy and unproductive world of ideology – which sometimes hides under the various banners of constructivism – to the sharp and productive world of theory-based research on how people learn” (Kirschner et al., 2006, p. 84). The experiential learning approach utilized in this study worked to be a productive and theory-based approach to learning. One major fallacy in the Kirschner et al. (2006) argument against experiential learning was that it was defined as an unguided method of instruction. In interpreting and extending the conclusions of this study, it is important to remember that experiential learning was a *guided* and purposeful process

that included careful planning and execution of a concrete experience, guided reflection, purposefully placed abstract conceptualizations attached to learning objectives, and planned active experimentation. It is incorrect to assume that this study serves as *confirmation* of the fuzzy and unproductive versions of experiential learning.

Conclusion 1: When taught either through experiential learning or direct instruction, students' analytical, creative, and practical performance, as well as motivation for the course, was not affected by student learning style.

Research has demonstrated, through both exploratory and confirmatory factor analysis, that there is an underlying two-factor ipsative structure of how students transform educational experiences congruent with Kolb's (1984) theory of experiential learning (Kayes, 2005). However, research indicating that a student's learning preferences have an effect on learning outcomes has produced conflicting messages. Rutz (2003) and Boyatzis and Mainemelis (2000) purported that a relationship exists between academic achievement and the converging learning style. Others have suggested improved academic performance for both converging and assimilating learning styles (Kolb, 1984; Lynch, Woelfl, Steel, & Hanssen, 1998; Malcom, 2009; Newland & Woelfl, 1992). Alireza, Mahyuddin, Elias, Shafee, and Shabani (2011), in reference to studies of learning styles and performance, explained that it was imperative to utilize measures beyond standard examinations because the differences between learning style products are not detectible without broader assessments. Sternberg and Grigorenko (2004) also shared that when students are taught in ways that meet how they learn, they outperform students who are not. The results of this study refute all of these claims of differences in student outcomes based on learning preferences.

This study explored the role of learning style in two very different instructional approaches, and utilized a number of various performance measures. Though differences were found between the learning approaches, learning style played no significant role in those differences. This finding seems more congruent with literature on a battery of learning style assessments that find they rarely play a significant role in formal learning processes (Cano, Garton, & Raven, 1992; Garton, Spain, Lamberson, & Spiers 1999; Thornton, Haskell, & Libby, 2006; Whittington & Raven, 1995). In formal educational settings, what is important is a blended approach where students each have the opportunity to work within their style (Baker et al., 2012). This holistic approach to learning is vital to the overall meta-cognitive growth of students as they build cognitive complexity, as explained by Kolb's (1984) developmental cone. Learning styles seem to be an effective framework to design instruction to develop the whole child as Dewey (1938) explained, rather than identifying a predictive mechanism to identify who is more likely to be successful at performing a given academic task. Kolb (1984) explained that, "the learning process is not identical for all human beings. Rather, it appears that the physiological structures that govern learning allow for the emergence of unique individual adaptive processes that tend to emphasize some adaptive orientations over others" (p. 62). Students employed different learning approaches, as made evident by their learning style differences, but found their way to the same end – different processes, same product. Educators should ask, "Are we providing experiences in classrooms that aid in the development of all students' unique cognitive processes?"

In agricultural education, the findings of this study indicate that students can benefit from experiential learning approaches regardless of their learning style. Kolb

(1984) explained that students have a preference, but that does not necessarily extend to the ability to perform tasks in various modes. As discussed in later conclusions, it was found that students' motivation, which includes a measure of satisfaction, was not significantly different across various learning styles. This seems to refute even the notion of preference for a mode. Though learning styles, as measured by the KLSI (Kolb, 1999), seem to exist, their effects on learning goals are irrelevant to student outcomes in this population. In agricultural education, focus on learning style should turn toward the framework as a guide to ensure students are exposed to the meta-cognitive process of all four modes of learning.

Conclusion 2: Students who were taught experientially had higher creativity scores when compared to those who were taught through direct instruction.

Kolb (1984) explained, in the theory of experiential learning, that creativity is a product of higher levels of integration, as depicted in the development cone. "Complexity and the integration of dialectic conflicts among the adaptive modes are the hallmark of true creativity and growth" (Kolb, 1984, p. 141). Interestingly, the findings of this study confirm Kolb's assertions that a lack of balance can lead to poor integration. Kolb (1984) cited a study by Altmeyer (1961) where students were administered two batteries of tests; one battery measured analytical reasoning, the other measured creative thinking. As expected, engineering/science students scored higher on analytical tests, while those in an arts program scored higher on creative thinking tests. This gap grew as students progressed in the respective programs. Further, engineering/science students *decreased* in their creative thinking while those in the arts *decreased* in their analytical ability. "Educational processes that accentuated one set of cognitive skills also appeared

to produce a loss of ability in the contrasting set of skills” (Kolb, 1984, p. 166). Too many times, in today’s climate of accountability steeped in the analytical domain, this same lack of balance could be occurring, which could debilitate the creativity of future citizens, employees, and business owners. In this study, students taught through direct instruction increased their analytical scores, while producing lower creativity scores. In the experiential group, analytical scores were lower than those in direct instruction, but significantly better in creative thinking. This finding, coupled with Kolb’s (1984) discussion, begs the question, “Are we aware of the unintended consequences of accountability through high stakes testing?”

Amabile (1996) explained the importance of social and environmental factors affecting creativity, and noted the importance of “openness” in classrooms (p. 206). Openness is defined as “less an approach or method than a set of shared attitudes and convictions about the nature of childhood, learning, and schooling” (Silberman, 1970, p. 208). This open style is viewed often as “a style of teaching involving flexibility of space, student choice of activity, richness of learning materials, integration of curriculum areas, and more individual or small-group than large-group instruction” (Horwitz, 1979, pp. 72-73). Horwitz (1979) reviewed 33 studies examining this open philosophy and practice and found that all noted statistically significant gains in student creativity. Perhaps this open style is connected to Kolb’s (1984) concept of high integration, growth, and creativity. The description of an open style seems congruent with the practice of secondary agricultural classrooms in Oklahoma and across the nation. The experiential treatment in this study fits this description of openness, while the direct instruction treatment was very scripted and orderly. This study would make the 34th in Horwitz’s

(1979) review of literature confirming the positive relationship of openness and creativity.

Could it be that the *unstructured* nature of agricultural education classrooms that is criticized most often by administrators and state leaders is actually the most beneficial element of the program? So often, educators, researchers, and stakeholders share that there is a *something* that is developed within agricultural education students that cannot be measured. Possibly, it cannot be measured because the measurements used are too narrowly focused on academic performance. This study confirmed that one of the *somethings* produced from experiential approaches to learning is the ability to operate creatively at high levels of integration. Though agricultural education is under direct pressure to become more academic (NRC, 1988), careful attention should be given to the development of a holistic and balanced approach to learning to avoid the potential unintended consequences of decreased creativity. This study provided evidence that a direct instruction approach produced higher analytical scores, but lower creativity scores. That analytical gain was ultimately gone after six weeks. So, is that investment worth the cost?

Conclusion 3: Students who were taught experientially had higher practical scores when compared to those who were taught through direct instruction.

Dewey (1938) spoke to the importance of practical applications of concepts learned in school.

We often see persons who have had little schooling and in whose case the absence of schooling proves to be an asset. They have at least retained their native

common sense and power of judgment. What avail is it to win prescribed amounts of information about geography and history, to win ability to read and write, if in the process the individual loses his own soul: loses his appreciation of things worth while, of the values to which these things are relative; if he loses his desire to apply what he has learned. (pp. 48 – 49)

This sentiment sits at the heart of the call for educational transformation producing graduates more prepared to handle the real-life problems faced in the workplace (NASSP, 1996, 2004; SCANS, 2001; Van Driel, Beijaard, & Verloop, 2001). The findings of this study provide evidence that an experiential approach to learning, as compared to that of direct instruction, yields greater practical use of knowledge taught. Eyler and Halteman (1981), Rhodes (1981), and Randi, Arrington, and Cheek (1993) demonstrated similar conclusions in both liberal education and agricultural education.

The increased practical skill development associated with an experiential learning technique seems to support the balanced holistic integration argument made in the discussion of conclusion three related to increased creativity. Practical extension of knowledge represents the more advanced complexity of development. Once again, by balancing the approach of instruction to include various modes of learning, additional student outcomes, like practical use of knowledge, are detected. Once again, it is important to ask, “What are the unintended consequences of a highly analytical-focused approach?” In this case, the direct instruction approach led to reduced practical use of the knowledge when compared to experiential learning.

In agricultural education, this conclusion holds important implications for the dual-purpose role of the program (Roberts & Ball, 2009). Though no longer called vocational, agricultural education has an important role in developing practical career skills as a part of the career and technical education arm of public education. Roberts and Ball (2009) explained that the curriculum should be driven partly by the needs of the agricultural industry – practical needs. Is it possible that agricultural education has become conditioned to brush off any notion of vocational education, and inadvertently *thrown out the baby with the bathwater*? Should the purpose of education be to prepare students for successful vocational pursuits – agricultural or otherwise? One theme continues to arise – a balanced approach to instruction provides the well-rounded education of students described by Kolb (1984) and called for by industry and universities.

Conclusion two and three, when viewed together, support the notion that experiential learning has more effect on the task-oriented performance outcomes. In contrast, direct instruction was more effective in delivering the more analytical elements of instruction, as discussed in conclusion four.

Conclusion 4: Students who were taught experientially had lower analytical scores when compared to those who were taught through direct instruction.

Conclusion four presented a somewhat divergent view to that of the often cited study by Specht and Sandlin (1991), which found that students in an experiential learning course scored no differently, statistically, to those who participated in a lecture-based format directly following the course. Literature in agricultural education (Cheek et al.,

1994) found a statistically significant and positive correlation between student involvement in SAE projects, often noted as the experiential component, and achievement on the agricultural class content examination. These conflicting findings beg the question, “Why the conflicting results?” In examining the nature of the study by Specht and Sandlin (1991), the experiential treatment involved a relatively classroom based format where lecture-based instruction was replaced with a case study approach. Additionally, curriculum was developed following Walter’s and Mark’s (1981) model of the experiential learning process, in contrast to Kolb’s (1984) experiential learning model utilized in this study. Finally, the study did not maintain experimental control and a number of nuisance variables, such as hours of independent study, dependency of student scores related to students working in groups, and variables associated with the diffusion of the treatments, could have had an impact on the analysis. Cheek et al. (1994) did not test the effect of experiential learning, but simply utilized correlations between course grades and a measure of experiential involvement. No attention was given to the methods of the experiential instruction; rather, the focus was to determine the level of involvement of students in a supervised agricultural experience program.

All learning is experiential (Kolb, 1984). As such, Roberts (2006) explained the importance of naming the context of a learning experience to understand better the effects and procedures employed. This difference in educational context could be the cause of the conflicting results. The Specht and Sandlin (1991) study was conducted over one full semester, where internalization was sought, the setting was more formal, and the level of knowledge was more abstract in nature. This study was conducted as a one-day clinical experiment that focused on both concrete and abstract levels of knowledge, was more

student-led, and sought internalization as an outcome. Under Kolb's (1984) premise that all learning is experiential, it may be too broad to only investigate *if* experiential learning is effective in developing successful intelligence. Research may be required to extend further into how different *types* of experiences affect students' successful intelligence.

Throughout the study, the preferred learning approach has been treated as a *this or that* proposal. In reality, the best approach for student learning might be a *both* approach. Sternberg (2002), in an article called *Raising the Achievement of All Students: Teaching for Successful Intelligence* included an additional element of teaching for memory learning and explained that, "teaching for memory is the foundation for all other teaching because students cannot think critically about what they know if they do not know anything" (Sternberg, 2002, p. 386). This study seems to conclude that a blended approach of direct instruction and experiential learning would be best to produce successful intelligence. Knowledge and analytical elements are taught best using direct instruction, while creative and practical elements are taught best using an experiential learning approach. Agricultural education is uniquely positioned such that it has the capacity to provide both direct instruction and experiential approaches to learning, which, as indicated by this study, would produce successful student intelligence.

Conclusion 5: Experiential learning and direct instruction approaches to learning produce similar student motivation outcomes.

Conclusion five was not consistent with what motivational effects were expected based on previous research findings. Stout (1996), much like Specht and Sandlin (1991), utilized an accounting college class and sought to determine the motivational effects of

experiential learning, as defined by a case study approach in comparison with a traditional college lecture approach. The study found that students involved in the experiential treatment were more motivated by the course, had a more positive outlook on accounting careers, were more interested in course content, and had a salutary impact on career specialization. Weinberg et al. (2011) yielded similar results with middle school students enrolled in a mathematics summer experiential program.

From the perspective of Kolb's (1984) experiential learning theory, this conclusion indicated that students, despite their preferred learning style, found work in various modes equally motivational. But what might happen if the instructional approaches were maintained over time restricting students from working in the various modes? Keller (1987) purported that, "relevance can come from the way something is taught; it does not have to come from the content itself" (p. 7). The findings of this study cannot confirm that claim. Any short-term effects on the four conditions for motivation based on the approach to instruction were not detected amongst the groups. Gay et al. (2009) offered another explanation related to the novelty effect, defined as, "increased interest, motivation, or engagement participants develop simply because they are doing something different" (p. 250). As noted in the limitations section of Chapter I, this study was conducted outside of the traditional school setting, which could have caused this unexpected equalization of motivational effect.

Conclusion 6: Students who were taught both experientially and through direct instruction experienced a statistically significant increase in analytical scores, but that increase was followed by a statistically significant decrease in analytical scores six weeks following instruction.

Specht and Sandlin (1991) noted that, “the results of this study suggest the key difference in the two learning methods may be in the area of students’ retention of the concepts rather than in their initial perceptions of those concepts” (p. 207). Though the methodology of this study mimicked the six week deferred post assessment, it failed to confirm this Specht and Sandlin’s (1991) assertion. Not only did students perform significantly lower on the analytical assessment directly after instruction than those who were taught using direct instruction, but they also did not retain the information six weeks later. It is important to note, however, that the analytical scores of students in both direct instruction and experiential approaches experienced a steep decline to near pre-test levels six weeks after instruction. Thus, analytical knowledge was not retained. Bransford, Brown, and Cocking (2000) would identify this problem as an inability to conditionalize the knowledge; learners did not see the relevance and failed to access what they knew when confronted with an opportunity for transfer.

This finding highlights a critical question for educational leaders to consider in educational reform. As states adopt the common core standards nationwide, and thus implement the PARCCS assessment, a greater pressure to conditionalize information will be required. Mere recall will no longer be sufficient. American education, of which agricultural education is subsumed, must carefully establish what the true aims of education should be. As policy directs, so schools should deliver. It is alarming to consider that the American public education system is spending a vast majority of the effort and resources on the banking of analytical knowledge, which this study indicated, is an investment with a rather short half-life.

Recommendations for Praxis

Based on the findings of this study, the following recommendations were made for practitioners in secondary agricultural education:

1. Although the study found that experiential learning improves students' creative and practical skills effectively, and while direct instruction delivered analytical knowledge more effectively, a blended approach is recommended. As shared by Kolb (1984), the goal is a balanced development of all four learning modes.
2. Agricultural educators should utilize Kolb's (1984) ELT as a framework for designing instruction so that experiential learning is not a mere notion, but a learning approach that requires careful planning and execution.
3. Secondary school systems should embrace both highly directive and experiential components of the school curriculum, as this combination produces successful student intelligence most effectively. An attempt to homogenize course and program offerings reduces the opportunities for students to develop cognitive complexity in all four modes.
4. Methods of assessment should be expanded. Traditional knowledge-based examinations measure only a portion of the elements key to successful intelligence. The products of teaching methods, like experiential learning, will not be captured with this traditional testing technique. Therefore, teachers should consider authentic assessments like the one employed in this study, plan opportunities for domain specific creativity assessments, and continue to assess knowledge through conceptual examinations.

5. Agricultural educators should plan more purposefully for the four learning modes when teaching experientially. For example, when students choose to participate in a livestock exhibition, teachers should create guided reflection purposefully, ensure students take the time to capture their abstract conclusions deduced through the experience, and prepare students to use those conclusions in subsequent similar experiences. As Dewey (1938) indicated, experience alone does not constitute learning. Experiences must be planned purposefully by the instructor, be of high quality, and lead to learning to be considered experiential *learning*. In agricultural education, *doing* does not necessarily constitute *learning*.
6. The aims and purposes of supervised agricultural experiences should be revisited. The SAE has the potential to be a powerful contributing element to development of successful student intelligence. However, it must be planned carefully and supported fully to include the balanced four-mode delivery, just as classroom instruction must.
7. Experiential learning is an effective method in addressing the needs of all types of learners. Students, regardless of their preferred learning style, can benefit and grow from all four modes of learning.

Further, based on the findings of this study, the following recommendations were presented for consideration by post-secondary teacher educators in agricultural education:

1. Operationalize experiential learning into a teaching method. Experiential learning is often well defined, but knowing how to deliver instruction in this manner pedagogically, is not addressed adequately. Aspiring agricultural educators must

understand how to guide students through each of the four modes of learning when facilitating student experiences to achieve the results noted in this study.

This training should include the development of educators' ability to serve in the facilitator, expert, evaluator, and coaching roles.

2. Continue to utilize the domain specific measurements, as demonstrated in this study, to measure creativity in various contexts. Many creativity instruments utilized in research measure general creativity as an inherent trait. Domain specific measurements related to the content can provide a better practical understanding of creativity.
3. Model the use of experiential curriculum, like that of the KidWind® kits utilized in this study, with pre-service agricultural educators, to create an awareness of the experiential learning process and how it is applied in various educational contexts.
4. Provide professional development to the current agricultural education teaching force to strengthen their ability to facilitate learning through experience, and move beyond the mere doing to enforce productivity versus activity.
5. Modify the way curriculum is designed in agricultural education to fit the experiential nature of the program. The vast majority of curriculum resources available to teachers today utilize a direct instruction approach to teaching, which is shown in this study to be inadequate as a stand-alone method. Provide instructional support and materials for the myriad of experiences available to secondary agricultural education students to ensure all four modes of learning are addressed.

Recommendations for Research

Though this study provided conclusions related to the stated research questions, a number of additional research questions arose as a product of this study. These research questions include:

1. What effects would similar treatments produce in other academic settings?
2. What is the effect of experiential learning, as operationalized in this study, if utilized by secondary teachers over a longer period of time in the traditional classroom setting?
3. The wind turbine task utilized in this study was a somewhat concrete task. How would the practical, analytical, and creative scores change with a more abstract task?
4. What happens to the creative and practical skills gained over a six-week period?
5. What is the effect of a blended approach to learning that included both direct instruction and experiential learning techniques?
6. Sternberg has recently added a wisdom measure to the theory of successful intelligence. How could that variable be measured in this setting and how would the instructional approaches impact that construct?
7. How do agricultural educators facilitate experiential learning opportunities currently? Are all four modes of learning addressed, and do teachers purposefully play the roles of facilitator, expert, evaluator, and coach?
8. How do students' learning styles affect their decisions to participate in various educational experiences?

9. What is the unique contribution of each of the learning modes to student performance? Do certain modes have more utility than others?
10. Is there a difference in effect associated with the order by which the four learning modes are followed?

Concluding Remarks

Experiential learning in agricultural education, when purposefully planned and executed, augments secondary curriculums by developing students practical and creative use of information. As shared by Baker et al. (2012), agricultural education is uniquely positioned to reap the benefits of an experiential approach to learning that is embedded in secondary school settings, like that of the school of interest in this study. As agricultural education continues to grow and develop the use of experiential learning approaches, it is important to heed the advice of Dewey (1938), “the only ground I can see for even a temporary reaction against [experiential education] is the failure of educators who professedly adopt them, to be faithful to them in practice” (p. 90). Agricultural educators must commit to experiential learning not only in name, but also in practice. Though this research provided empirical support for experiential learning, could it be that we are really talking about *good teaching* under a myriad of names. Dewey (1938) concluded *Experience and Education* with an important reminder:

What we want and need is education pure and simple, and we shall make surer and faster progress when we devote ourselves to finding out just what education is and what conditions have to be satisfied in order that education may be a reality

and not a name or a slogan. It is for this reason alone that I have emphasized the need for a sound philosophy of experience. (p. 91)

REFERENCES

- Abbey, D. S., Hunt, D. E., & Weiser, J. C. (1985). Variations on a theme by Kolb: A new perspective for understanding counseling and supervision. *The Counseling Psychologist, 13*(3), 477-501. (ERIC Document Reproduction Services No. EJ325003).
- Abdulwahed, M., & Nagy, Z. K. (2009). Applying Kolb's experiential learning cycle for laboratory education, *Journal of Engineering Education, 98*(3), 283-294.
Retrieved from <http://search.proquest.com/docview/217954663?accountid=4117>.
- Adams, G. L., & Engelmann, S. (1996). *Research on direct instruction: 25 years beyond DISTAR*. Seattle, WA: Educational Achievement Systems.
- Alireza, J. D., Mahyuddin, R., Elias, H., Shafee, M. D., & Shabani, J. (2011). Academic achievement of students with different learning styles. *International Journal of Psychological Studies, 3*(2), 186-192. Retrieved from <http://search.proquest.com/docview/1017694828?accountid=4117>.

- Altmeyer, R. (1961). *Education in the arts and sciences: Divergent paths* (Doctoral dissertation). Retrieved from ERIC.
- Amabile, T. M. (1996). *Creativity in context*. Boulder, CO: Westview.
- Anyadoh, E. B., & Barrick, R. K. (1990). *Relationship between selected teacher program and student characteristics and student scores on their supervised occupational experience program in Ohio*. (Report No. CE 055 845). Columbus, OH: The Ohio State University, Department of Agricultural Education (ERIC Document Reproduction Service No. ED 324 411).
- Andreson, L., Boud, D., & Cohen, R. (2000). Experience-based learning. In G. Foley (Eds.), *Understanding adult education training* (2nd ed., pp. 225-239). Sydney: Allen & Unwin.
- Ary, D., Jacobs, L. C., & Razavieh, A. (2002). *Introduction to research in education* (6th ed.). Belmont, CA: Wadsworth/Thomson Learning.
- Atkinson, J. W. (1957). Motivational determinants of risk-taking behavior. *Psychological Review*, 64(6, Pt.1), 359-372. doi:10.1037/h0043445
- Baker, M. A., Robinson, J. S., & Kolb, D. H. (2012). Aligning Kolb's experiential learning theory with a comprehensive agricultural education model. *Journal of Agricultural Education*, 53(4), 1-16. doi: 10.5032/jae.2012.04001
- Bandura, A. (1977). Self-efficacy: Toward a unifying theory of behavioral change. *Psychological Review*, 84(2), 191-215. doi:10.1037/0033-295X.84.2.191

- Bandura, A., & Schunk, D. H. (1981). Cultivating competence, self-efficacy, and intrinsic interest through proximal self-motivation. *Journal of Personality and Social Psychology*, *41*(3), 586-598. doi:10.1037/0022-3514.41.3.586
- Barrick, R. K., & Estepp, C. M. (2011). Experience programs in agriscience education: From projects to SAEP's and beyond. *The Agricultural Education Magazine*, *83*(4), 26.
- Battle, E. S. (1966). Motivational determinants of academic competence. *Journal of Personality and Social Psychology*, *4*(6), 634-642. doi:10.1037/h0024028
- Beard, C., & Wilson, J. P. (2006). *Experiential learning: A best practice handbook for educators and trainers*. Philadelphia, PA: Kogan Page Limited.
- Becker, W. C. (1992). Direct Instruction: A twenty year review. In R. P. West & L. A. Hamerlynck (Eds.), *Designs for excellence in education: The legacy of B. F. Skinner* (pp. 71-112). Longmont, CO: Sopris West.
- Becker, W. C., & Carnine, D. W. (1980). Direct instruction: An effective approach to educational intervention with disadvantaged and low performers. In B. B. Lahey & A. E. Kazdin (Eds.), *Advances in clinical child psychology* (Vol. 3, pp. 429-473). New York, NY: Plenum.
- Begeny, J. C., & Martens, B. K., (2006). Assessing pre-service teachers' training in empirically-validated behavioral instruction practices. *School Psychology Quarterly*, *21*(3), 262-285. doi: 10.1521/scpq.2006.21.3.262

- Benson, P. W. (1981). *Comparison of affective work competencies and selected background experiences of students, graduates, and supervisors in agricultural mechanization*. Dissertation Abstracts International, 42, 59A.
- Binet, A., & Simon, T. (1916). *The development of intelligence in children*. Baltimore, MD: Williams & Wilkins.
- Birch, L., Jones, N., Doyle, P. M., Green, A., McLaughlin, C., Champney, C.,... Taylor, K. (2007). Obstetric skills drill: Evaluation of teaching methods. *Nurse Education Today*, 27, 915–922. doi: 10.1016/j.nedt.2007.01.006
- Bloom, B. S. (1956). *Taxonomy of educational objectives. The classification of educational goals. Handbook 1: Cognitive domain*. New York, NY: McKay.
- Bock, G., Stebbins, L., & Proper, E. (1977). *Education as experimentation: A planned variation model (Volume IV-A & B). Effects of follow through models*. Washington, DC: Abt Associates.
- Boyatzis, R. E., & Mainemelis, C. (2000). *An empirical study of pluralism of learning and adaptive styles in a MBA Program*. Department of Organizational Behavior. Case Western Reserve University, Cleveland, OH.
- Bransford, J. D., Brown, A., & Cocking, R. R. (2000). *How people learn: Brain, mind, experience, and school*. Washington, DC: National Academies Press.
- Bronfenbrenner, U. (1977). Toward an experimental ecology of human development. *American Psychologist*, 32(7), 513–532. doi: 10.1037/0003-066X.32.7.513

- Bronfenbrenner, U. (1979). *The ecology of human development*. Cambridge, MA: Harvard University Press.
- Brookes, A. (2002). Lost in the Australian bush: Outdoor education as curriculum. *Journal of Curriculum Studies*, 34(4), 405-425. doi: 10.1080/00220270110101805
- Bruner, J. S. (1966). *On knowing: Essays for the left hand*. New York, NY: Atheneum.
- Burton, M. G. (1915). *Shop projects based on community problems*. University of California Libraries.
- Camp, W. G., Clarke, A., & Fallon, M. (2000). Revisiting supervised agricultural experience. *Journal of Agricultural Education*, 41(3), 13-22. doi: 10.5032/jae.2000.03013
- Campbell, D. T., & Stanley, J. C. (1966). *Experimental and quasi-experimental designs for research*. Chicago, IL: Rand McNally.
- Cano, J., Garton, B. L., & Raven, M. R. (1992). The relationship between learning and teaching styles and student performance in methods of teaching agriculture course. *Journal of Agricultural Education*, 33(3), 16-22. doi:10.5032/jae.1992.03016
- Cavanagh, S. (2004). Students ill-prepared for college, ACT warns. *Education Week*, 24(8), 5.
- Cheek, J. G., Arrington, L. R., Carter, S., & Randall, R. S. (1994). Relationship of supervised agricultural experience program participation and student achievement

in agriculture. *Journal of Agricultural Education*, 35(2), 1–5. doi:
10.5032/jae.1994.02001

Cheek, J. G. & McGhee, M. (1985). Assessment of competencies possessed by students enrolled in applied principles of agribusiness and natural resource education. *The Journal of the American Association of Teacher Educators in Agriculture*, 24(4), 55-65.

Cohen, J. (1977). *Statistical power analysis for the behavioral sciences*. New York, NY: Academic Press.

Cohen, J., & Kinsey, D. (1994). ‘Doing good’ and scholar-ship: A service-learning study. *Journalism Educator*, 48(4), 4-14.

Constas, M. A., & Sternberg, R. J. (Eds.). (2006). Translating theory and research into educational practice: *Developments in content domains, large scale reform, and intellectual capacity*. Lawrence Erlbaum.

Crandall, V. C. (1969). Sex difference in expectancy of intellectual and academic reinforcement. In Smith, C. P. (Ed.), *Achievement-Related Motives in Children*, New York, NY: Russell Sage Foundation.

Creswell, J. W. (2008). *Educational research: Planning, conducting, and evaluating quantitative and qualitative research*. Upper Saddle River, NJ: Pearson Education, Inc.

Cronbach, L. J. (1970). *Essentials of psychological testing* (3rd ed.). New York, NY: Harper & Row.

- Dale, E. (1946). *Audio-visual methods in teaching*. New York, NY: The Dryden Press.
- Dewey, J. (1897). My pedagogic creed. *The School Journal*. *LIV*(3), 77–80.
- Dewey, J. (1916). *Democracy and education*.
- Dewey, J. (1934). *Art as experience*. New York, NY: Capricorn Books.
- Dewey, J. (1938). *Education and experience*. New York, NY: Simon and Schuster.
- Dewey, J. (1958). *Experience and nature*. New York, NY: Dover Publications, Inc.
- Dewey, J. (1997). *How we think*. Mineola, NY: Dover Publications, Inc.
- Doerfert, D. L. (Ed.) (2011). *National research agenda: American Association for Agricultural Education's research priority areas for 2011-2015*. Lubbock, TX: Texas Tech University, Department of Agricultural Education and Communications.
- Doolittle, P. E., & Camp, W. G. (1999). Constructivism: The career and technical education perspective. *Journal of Vocational and Technical Education*, *16*(1). Retrieved from: <http://scholar.lib.vt.edu/ejournals/JVTE/v16n1/doolittle.html>
- Dweck, C. S. (1986). Motivational processes affecting learning. *American Psychologist*, *41*(10), 1040-1048. doi:10.1037/0003-066X.41.10.1040
- Eccles, J. S., Adler, T. F., Futterman, R., Goff, S. B., Kaczala, C. M., Meece, J., and Midgley, C. (1983). Expectancies, values and academic behaviors. In Spence, J. T. (Ed.), *Achievement and Achievement Motives*. San Francisco, CA: W. H. Freeman.

- Elkind, D. (1970). *Children and adolescence: Interpretative essays on Jean Piaget*. New York, NY: Oxford University Press.
- Etling, A. (1993). What is non-formal education? *Journal of Agricultural Education*, 34(4), 72-76. doi: 10.5032/jae.1993.04072
- Ewert, A., & Sibthorp, J. (2009). Creating outcomes through experiential education: The challenge of confounding variables. *The Journal of Experiential Education*, 31(3), 376-389. Retrieved from <http://search.proquest.com/docview/274969892?accountid=4117>
- Eyler, J. (2009). The power of experiential education. *Liberal Education*, 95(4), 24-31. Retrieved from <http://search.proquest.com/docview/209817016?accountid=4117>
- Eyler, J., & Giles Jr., D. E. (1999). *Where's the learning in service learning?* San Francisco, CA: Jossey-Bass.
- Eyler, J., & Halteman, B. (1981). Socialization for political participation: The impact of legislative internship on students' political skillfulness and sophistication. *Teaching Political Science*, 9(1), 27-35.
- Faul, F., Erdfelder, E., Lang, A.-G., & Buchner, A. (2007). G*Power 3: A flexible statistical power analysis program for the social, behavioral, and biomedical sciences. *Behavior Research Methods*, 39, 175-191.
- Feather, N. T. (1992). Expectancy-value theory and unemployment effects. *Journal Of Occupational & Organizational Psychology*, 65(4), 315-330. doi: 10.1111/j.2044-8325.1992.tb00508.x

- Ferguson, R. (2004). Crisis at the core: Preparing all students for College and Work.
Prepared for ACT, information for life's transitions. Retrieved January, 18, 2011.
Retrieved from ERIC # ED493181
- Field, A. (2009). *Discovering statistics using SPSS (3rd ed.)*. Thousand Oaks, CA: Sage Publications, Inc.
- Fink, L. D. (1984). *The first year of college teaching. New directions for teaching and learning, no. 17*. San Francisco, CA: Jossey-Bass.
- Fink, L. D. (2003). *Creating significant learning experiences: An integrated approach to designing college courses*. San Francisco, CA: Jossey-Bass.
- Fitzgerald, N. E. (1936). A philosophy for vocational education in agriculture.
Agricultural Education, 71, 77.
- Freire, P. (1973). Education for critical consciousness. New York, NY: Continuum.
- Freire, P. (1974). Pedagogy of the oppressed. New York, NY: Continuum.
- Futrell, M. H. (2010). Transforming teacher education to reform America's P – 20 education system. *Journal of Teacher Education, 61(5)*, 432-440. doi: 10.1177/0022487110375803
- Gardner, H. (1983). *Frames of mind: The theory of multiple intelligences*. New York, NY: Basic Books.

- Garner, I. (2000). Problems and inconsistencies with Kolb's learning styles. *Educational Psychology, 20*(3), 341-348. Retrieved from <http://search.proquest.com/docview/208810739?accountid=4117>
- Garton, B. L., Spain, J. N., Lamberson, W. R., & Spiers, D. E. (1999). Learning styles, teaching performance, and student achievement: A relational study. *Journal of Agricultural Education, 40*(3), 11-20. doi:10.5032/jae.1999.03011
- Gass, M. (2005). Comprehending the value structures influencing significance and power behind experiential education research. *Journal of Experiential Education, 27*(3), 286-296.
- Gay, L. R., Mills, G. E., & Airasian, P. (2009). *Educational research: Competencies for analysis and applications*. Upper Saddle River, NJ: Pearson.
- Geiger, M. A., Boyle, E. J., & Pinto, J. (1993). A factor analysis of Kolb's revised learning style inventory. *Educational and Psychological Measurement, 52*, 753-759.
- Gersten, R., Carnine, D., & White, W. A. T. (1984). The pursuit of clarity: Direct instruction and applied behavior analysis. In W. L. Heward, T. E. Heron, D. S. Hill, & J. Trap-Porter, *Focus on behavior analysis in education* (pp. 38-57). Columbus, OH: Merrill.
- Grigorenko, E. L., & Sternberg, R. J. (2001) Analytical, creative, and practical intelligence as predictors of self-reported adaptive functioning: a case study in Russia. *Intelligence, 26*(1), 57-73. doi: 10.1016/S0160-2896(00)00043-X

- Guilford, J. P. (1950). Creativity. *American Psychologist*, 5, 444-454.
- Heald, F. E. (1929). Our leadership in agricultural education: Rufus W. Stimson, pioneer. *The Agricultural Education Magazine*, 1(3), 3-4, 14-15.
- Horwitz, R. A. (1979). Psychological effects of the open classroom. *Review of Educational Research*, 49, 71-85. Retrieved from <http://www.jstor.org/stable/1169927>
- Hughes, M., & Barrick, R. K. (1993). A model for agricultural education in public schools. *Journal of Agricultural Education*, 34(3), 59-67. doi: 10.5032/jae.1993.03059
- Hunt, D. E. (1987). *Beginning with ourselves*. Cambridge, MA: Brookline.
- Itin, C. M. (1999). Reasserting the philosophy of agricultural education as a vehicle for change in the 21st century. *Journal of Experiential Education*, 22(2), 91-98. Retrieved from <http://search.proquest.com/docview/275022811?accountid=4117>
- James, W. (1890). *The principles of psychology: Volumes I and II*. New York, NY: Holt, Rinehart, and Winston.
- James, W. (1907). *Pragmatism: A new name for some old ways of thinking*. New York, NY: Longmans, Green and Company.
- James, W. (1912). *Essays in radical empiricism*. New York, NY: Longmans, Green and Company.

- Joplin, L. (1981). On defining experiential education. *Journal of Experiential Education*, 4(1), 17-20.
- Joyce, B., & Weil, M. (2000). *Models of teaching* (6th ed.). Boston, MA: Allyn and Bacon.
- Jung, C. (1923). *Psychological types*. New York, NY: Harcourt Brace.
- Jung, C. (1960). *The structure and dynamics of the psyche*. New York, NY: Bollingen Foundation.
- Jung, C. (1977). *Psychological Types*. R.F.C. Hull, trans., Collected Works of C.G. Jung, Vol. 6. Bollingen Series XX, Princeton University Press, pp. 12-13, 28, 68.
- Kane, M. T. (1986). The role of reliability in criterion-referenced tests. *Journal of Educational Measurement*, 23(3), 221-224.
- Kayes, D. C. (2005). Internal validity and reliability of Kolb's learning style inventory version 3 (1999). *Journal of Business and Psychology*, 20(2), 249-257. doi: 10.1007/s10869-005-8262-4
- Keller, J. M. (1979). Motivation and instructional design: A theoretical perspective. *Journal of Instructional Development*, 2(4), 26-34. doi: 10.1007/BF02904345
- Keller, J. M. (1984). The use of the ARCS model of motivation in teacher training. In K. E. Shaw (Ed.), *Aspects of educational technology volume XVII: Staff development and career updating*. London; Kogan Page.

- Keller, J. M. (1987). Development and use of the ARCS model of instructional design. *Journal of Instructional Development*, 10(3), 2-10. Retrieved from <http://www.jstor.org/stable/30221294>
- Keller, J. M. (2006). *Development of two measures of learner motivation*. (Unpublished draft in progress). Florida State University, Tallahassee, FL.
- Kendrick, J. (1996). Outcomes of service-learning in an introduction to sociology course. *Michigan Journal of Community Service Learning*, 3, 72-81.
- Kirk, R. E. (1995). *Experimental design: Procedures for the behavioral sciences* (3rd ed.). Pacific Grove, CA: Brooks/Cole Publishing Company.
- Kirschner, P. A., Sweller, J., & Clark, R. E. (2006). Why minimal guidance during instruction does not work: An analysis of the failure of constructivist, discovery, problem-based, experiential, and inquiry-based teaching. *Educational Psychologist*, 41(2), 75-86. doi:10.1207/s15326985ep4102_1
- Knobloch, N. A. (2003). Is experiential learning authentic? *Journal of Agricultural Education*, 44(4), 22-34. doi: 10.5032/jae.2003.04022
- Kolb, D. A. (1984). *Experiential learning: Experience as the source of learning and development*. Upper Saddle River, NJ: Prentice Hall.
- Kolb, D. A. (1985). Learning style inventory, version 2. Boston, MA: The McBer.
- Kolb, D. A. (1996). Learning style inventory, version 2A. Boston, MA: Hay-McBer.
- Kolb, D. A. (1999). Learning style inventory, version 3. Boston, MA: The Hay Group.

- Kolb, D. A. (2007). *The Kolb learning style inventory—Version 3.1: LSI workbook*. Boston, MA: Hay Learning Transformations.
- Kolb, A., & Kolb, D. A. (2005a). *Experiential learning theory bibliography*. Experience Based Learning Systems, Inc. Cleveland, OH. Retrieved from www.learningfromexperience.com.
- Kolb, A., & Kolb, D. A. (2005b). Learning styles and learning spaces: Enhancing experiential learning in higher education. *Academy of Management Learning & Education*, 4(2), 193–212.
- Kolb, A., & Kolb, D. A. (2009). The learning way: Meta-cognitive aspects of experiential learning. *Simulation Gaming*, 40, 297-327. doi: 10.1177/1046878108325713
- Kotrlik, J. W., Parton, G., & Leile, M. (1986). Factors associated with knowledge level attained by vocational agriculture II students. *The Journal of the American Association of Teacher Educators in Agriculture*, 27(2), 34-39.
- Koziuff, M. A., LaNunziata, L., Cowardin, J., & Bessellieu F. B., (2001). Direct instruction: Its contributions to high school achievement. *The High School Journal*, 84(2), 54-71. Retrieved from <http://www.jstor.org/stable/40364405>
- Lang, H. (1982). Criterion-referenced tests in science: An investigation of reliability, validity, and standards-setting. *Journal of Research in Science Teaching*, 19(8), 665-674. doi: 10.1002/tea.3660190806

- Lewin, K. (1938). *The conceptual representation and measurement of psychological forces*. Durham, NC: Duke University Press.
- Lewin, K. (1951). *Field theory in social sciences*. New York, NY: Harper & Row.
- Light, R., Singer, J., & Willett, J. (1990). *By design*. Cambridge, MA: Harvard University Press.
- Loo, R. (1999a). Issues in factor-analyzing ipsative measures: The learning style inventory (LSI-1985) example. *Journal of Business and Psychology*, *14*(Fall), 149–154. doi: 10.1023/A:1022918803653
- Loo, R. (1999b). Confirmatory factor analysis of Kolb's learning style inventory (LSI-1985). *British Journal of Educational Psychology*, *69*, 213–219.
doi: 10.1348/000709999157680
- Lynch, T. G., Woelfl, N. N., Steele, D. J., & Hanssen, C. S. (1998). Learning style influences examination performance. *American Journal of Surgery*, *176*(1), 62-66.
Retrieved from [http://dx.doi.org/10.1016/S0002-9610\(98\)00107-X](http://dx.doi.org/10.1016/S0002-9610(98)00107-X)
- Malcom, M. (2009). *The relationship between learning styles and success in online learning*. (Northcentral University). *ProQuest Dissertations and Theses*, 90-n/a.
Retrieved from <http://search.proquest.com/docview/305177952?accountid=4117>.
(305177952).
- Markus, G. B., Howard, J. P., & King, D. C. (1993). Notes: Integrating community service and classroom instruction enhances learning: Results from an experiment.

Educational Evaluation and Policy Analysis, 15(4), 410-419. doi:
10.2307/1164538

McGraw Hill/SRA, Direct instruction methodology. (N. D.).

McLean, R. C., & Camp, W. G. (2000). An examination of selected agricultural teacher education programs in the United States. *Journal of Agricultural Education*, 41(2), 23–35. doi: 10.5032/jae.2000.02023

Millenbah, K. F., & Millspaugh, J. J. (2003). Using experiential learning in wildlife courses to improve retention, problem solving, and decision-making. *Wildlife Society Bulletin* 31(1), 127-137. Retrieved from <http://www.jstor.org/stable/3784366>.

Miller, J. (1994). Linking traditional and service-learning courses: Outcome evaluations utilizing two pedagogically distinct models. *Michigan Journal of Community Service Learning*, 1, 29-36.

Miller, L. E. (1998). Appropriate analysis. *Journal of Agricultural Education*, 39(2), 1-10. doi: 10.5032/jae.1998.02001

Moore, D. T. (1999). Behind the wizard's curtain: A challenge to the true believer. *NSEE Quarterly*, 25(1), 23- 27.

Moore, D. W. (2007). Direct Instruction: Targeted Strategies for Student Success. *Best Practices in Secondary Education*. Retrieved from http://insideng.com/profdev/guides/Moore_Instruction.pdf

National Association of Secondary School Principals. (1996). *Breaking ranks: Changing an American institution*. A report of the National Association of Secondary School Principals in partnership with the Carnegie Foundation. Reston, VA: NASSP.

National Association of Secondary School Principals. (2004). *Breaking ranks II: Strategies for leading high school reform*. A report of the National Association of Secondary School Principals in partnership with the Education Alliance at Brown University. Reston, VA: NASSP.

National Center for Educational Statistics (NCES). (2011). *Highlights from PISA 2009: Performance of U.S. 15-year-old students in reading, mathematics, and science literacy in an international context*. (NCES 2011-004) Retrieved from <http://nces.ed.gov/pubsearch/pubsinfo.asp?pubid=2011004>

National FFA Organization. (2008). *Official FFA Manual*. Indianapolis, IN: National FFA Organization.

National Research Council. (1988). *Understanding agriculture: New directions for education*. [Electronic Version]. Committee on Agricultural Education in Secondary Schools, Board on Agricultural Education in Secondary Schools, Board on Agriculture, and the National Research Council. Retrieved from National Academics Press: http://www.nap.edu/catalog.php?record_id=766

Neisser, U. (1963). The imitation of man by machine. *Science*, 139, 193-197. Retrieved from <http://www.jstor.org/stable/1710006>.

- Newland, J. R., & Woelfl, N. N., (1992). Learning style inventory and academic performance of students in general pathology. *Bulletin of Pathology Education, 17*: 77-81.
- Osborne, R.E., Hammerich, S., & Hensley, C. (1998). Student effects of service-learning: Tracking change across a semester. *Michigan Journal of Community Service Learning, 5*, 5-13.
- Pearson, P. D., & Gallagher, M. (1983). The instruction of reading comprehension. *Contemporary Educational Psychology, 8*, 317-344. doi: 10.1016/0361-476X(83)90019-X
- Phipps, L. J., Osborne, E. W., Dyer, J. E., & Ball, A. (2008). *Theoretical foundations of effective teaching: Handbook on agricultural education in public schools* (6th ed.). Clifton Park, NY: Thomson Delmar Learning.
- Piaget, J. (1971). *Psychology and Epistemology*. Middlesex, UK: Penguin Books.
- Piaget, J., & Inhelder, B. (1969). *Psychology of the child*. New York, NY: Basic Books.
- Piaget, J., & Kamii, C. (1978). What is psychology? *American Psychologist, 33*(7), 648-652. doi:10.1037/0003-066X.33.7.648
- Popham, W. J., & Husek, T. R. (1969). Implications of criterion-referenced measurement. *Journal of Educational Measurement, 6*, 1-9. Retrieved from <http://www.jstor.org/stable/1433917>

- President's Council of Advisors on Science and Technology (US). (2010). *Prepare and Inspire: K-12 education in science, technology, engineering, and math (STEM) for America's future: Executive report*. Executive Office of the President, President's Council of Advisors on Science and Technology.
- Randell, R. S., Arrington, L. R., & Cheek, J. G. (1993). The relationship of supervised agricultural experience program participation and student achievement in practical skills in agricultural science. *Journal of Agricultural Education, 34*(1), 26-32. doi: 10.5032/jae.1993.01026
- Resnick, L. B. (1987). The 1987 presidential address: Learning in school and out, *Educational Researcher, 16*(9), 13-20. doi: 10.3102/0013189X016009013
- Retallick, M. S. (2003). Reframing SAE: The tricycle principle. *Agricultural Education Magazine, 75*(6), 8-9.
- Rhodes, K. B. (1981). *Student achievement and the use of a greenhouse-production record book and potted-chrysanthemum unit of instruction* (Doctoral dissertation). Retrieved from Dissertation Abstracts International (41, 3841A).
- Roberts, J. W. (2012). *Beyond learning by doing: Theoretical currents in experiential education*. New York, NY: Routledge.
- Roberts, T. G. (2006). A philosophical examination of experiential learning theory for agricultural educators. *Journal of Agricultural Education, 47*(1), 17–29. doi: 10.5032/jae.2006.01017

- Roberts, T. G., & Ball, A. L. (2009). Secondary agricultural science as content and context for teaching. *Journal of Agricultural Education*, 50(1), 81-91. doi: 10.5032/jae.2009.01081
- Rogers, C. (1961). *On becoming a person*. Boston, MA: Houghton Mifflin.
- Rosenshine, B. & Meister, C. (1992). The use of scaffolds for teaching higher-level cognitive strategies. *Educational Leadership*, 50, 26-33. Retrieved from <http://search.proquest.com/docview/224851761?accountid=4117>
- Rutz, E. (2003). *Learning styles and educational performance: Implications for professional development programs*. CIEC Conference proceedings, Tuscon, AZ.
- Savage, G. (2010). "Problematizing 'Public Pedagogy' in Educational Research." In J. Sandlin, B. Shultz, & J. Burdick (eds.), *Handbook of public pedagogy: Education and learning beyond schooling* (p. 103). New York, NY: Rutledge
- Secretary's Commission on Achieving Necessary Skills, U.S. Department of Labor. (2001). Learning a living: A blueprint for high performance. SCANS report for America 2000 executive summary principles and recommendations. In *The Jossey-Bass Reader on School Reform*. San Francisco, CA: Jossey-Bass.
- Spearman, C. E. (1904). "General intelligence" objectively determined and measured. *American Journal of Psychology*, 15(2), 201-293. doi:10.1037/h0065005
- Specht, L. B., & Sandlin, P. K. (1991). The differential effects of experiential learning activities and traditional lecture classes in accounting. *Simulation Gaming*, 22(2), 196-210. doi: 10.1177/1046878191222003

- Stehno, J. J. (1986). *The application and integration of experiential education in higher education*. Carbondale, IL: Southern Illinois University, Touch of Nature Environmental Center. (ERIC Document Reproductive Service No. ED 285-465).
- Steinaker, N. W., & Bell, M. R. (1979). *The experiential taxonomy: A new approach to teaching and learning*. New York, NY: Academic Press.
- Steinke, P., & Buresh, S. (2002). Cognitive outcomes of service-learning: Reviewing the past and glimpsing the future. *Michigan Journal of Community Service Learning*, 8, 5–14.
- Sternberg, R. J. (1993). *Sternberg Triarchic Abilities Test (STAT)*. Unpublished test.
- Sternberg, R. J. (1998). Principles of teaching for successful intelligence. *Educational Psychologist*, 33(2/3), 65-72. doi: 10.1207/s15326985ep3302&3_2
- Sternberg, R. J. (1999a). The theory of successful intelligence. *Review of General Psychology*, 3(4), 292-316. doi: 1089-2680/99
- Sternberg, R. J. (1999b). Successful intelligence: Finding a balance. *Trends in Cognitive Sciences*, 3(11), 436-442. doi:10.1016/S1364-6613(99)01391-1
- Sternberg, R. J. (2002). Raising the achievement of all students: Teaching for successful intelligence. *Educational Psychology Review*, 14(4), 383-393. doi: 1040-726X/02/1200-0383/0
- Sternberg, R. J. (2006). The rainbow project: Enhancing the SAT through assessments of analytical, practical, and creative skills. *Intelligence*, 34, 321-350. doi:10.1016/j.intell.2006.01.002

- Sternberg, R. J., Castejón, J. L., Prieto, M. D., Hautamäki, J., & Grigorenko, E. L. (2001).
Confirmatory factor analysis of the Sternberg Triarchic Abilities Test in three
international samples: An empirical test of the triarchic theory of intelligence.
European Journal of Psychological Assessment, 17(1), 1-16. doi:
<http://dx.doi.org/10.1027/1015-5759.17.1.1>
- Sternberg, R. J., & Clinkenbeard, P. R. (1995). The tri-archic model applied to
identifying, teaching, and assessing gifted children. *Roepers Review, 17*(4), 255-
260.
- Sternberg, R. J., Ferrari, M., Clinkenbeard, P. R., & Grigorenko, E. L. (1996).
Identification, instruction, and assessment of gifted children: A construct
validation of a triarchic model. *Gifted Child Quarterly, 40*, 129-137.
- Sternberg, R. J., & Grigorenko, E. L. (2004). Successful intelligence in the classroom.
Theory Into Practice, 43(4), 274-280. Retrieved from
<http://www.jstor.org/stable/3701535>
- Sternberg, R. J., Grigorenko, E. L., Ferrari, M., & Clinkenbeard, P. R. (1999). A
triarchic analysis of an aptitude-treatment interaction. *European Journal of
Psychological Assessment, 15*(1), 1-11.
- Sternberg, R. J., Torff, B., & Grigorenko, E.L. (1998a). Teaching for successful
intelligence raises school achievement. *Phi Delta Kappan, 79*(9), 667-669.
Retrieved from <http://www.jstor.org/stable/20439306>

- Sternberg, R. J., Torff, B., & Grigorenko, E.L. (1998b). Teaching triarchically improves school achievement. *Journal of Educational Psychology, 90*, 1-11. doi: 10.1037/0022-0663.90.3.374
- Stevens, J. P. (2009) *Applied multivariate statistics for the social sciences* (5th ed.). New York, NY: Routledge.
- Stewart, B. R., & Birkenholz, R. J. (1991). Outcomes of changing supervised agricultural education programs. *Journal of Agricultural Education, 32*(3), 35–41. doi: 10.5032/jae.1991.03035
- Stimson, R. W. (1919). *Vocational agricultural education by home projects*. The Macmillan company.
- Stout, D. E. (1996). Experiential evidence and recommendations regarding case-based teaching in undergraduate cost accounting. *Journal of Accounting Education, 14*(3), 293-317. doi: 10.1016/0748-5751(96)00023-1
- Team Ag Ed. (2004). National FFA Organization. Retrieved from <http://www.ffa.org/html/teamagedindex.html>.
- Thornton, B., Haskell, H., & Libby, L. (2006). A comparison of learning styles between gifted and non-gifted high school students. *Individual Differences Research, 4*(2), 106-110.
- Thurstone, L. L. (1938). *Primary mental abilities*. Chicago, IL: University of Chicago Press.
- Tolman, E. C. (1932). *Purposive behavior in animals and men*. New York, NY: Century.

- Torrance, E. P. (1974). *Torrance Tests of Creative Thinking*. Lexington, MA: Personnel Press.
- Tyler, L. (1978). *Individuality*. San Francisco, CA: Jossey-Bass.
- Urbaniak, G. C., & Plous, S. (2011). Research Randomizer (Version 3.0) [Computer software]. Retrieved from <http://www.randomizer.org/>
- Van Driel, J. H., Beijaard, D., & Verloop, N. (2001). Professional development and reform in science education: The role of teachers' practical knowledge. *Journal of Research in Science Teaching*, 38(2), 137-158. doi:10.1002/1098-2736(200102)38:2<137::AID-TEA1001>3.0.CO;2-U
- Vygotsky, L. S. (1978). *Mind and Society: The development of higher psychological processes*. Cambridge, MA: Harvard University Press.
- Walter, G. A., & Marks, S. E. (1981). *Experiential learning and change: Theory, design, and practice*. New York, NY: Wiley.
- Watkins, C. (1997). *Project follow through: A case study of contingencies influencing instructional practices of the educational establishment*. Cambridge, MA: Cambridge Center for Behavioral Studies.
- Watkins, C. L., & Slocum, T. A. (2003). The components of direct instruction. *Journal of Direct Instruction*, 3(2), 75-110. Retrieved from: <http://www.adihome.org/di-programs/197>
- Warren, R. J., & Flowers, J. (1992). *The relationship between the quality of the supervised agricultural experience component of the secondary agriculture*

program in North Carolina and the instructors' levels of time management.

Paper presented at the Nineteenth Annual National Agricultural Education Research Meeting, St. Louis, MO.

Washington Office of Superintendent of Public Instruction. (2004). *Career and technical education*. Retrieved from <http://www.k12.wa.us/CareerTechEd/default.aspx>

Weinberg, A. E., Basile, C. G., & Albright, L. (2011). The effect of an experiential learning program on middle school students' motivation toward mathematics and science. *RMLE Online*, 35(3), 1-12. Retrieved from <http://search.proquest.com/docview/915971749?accountid=4117>

Weiss, M. J. (2010). The implications of teacher selection and the teacher effect in individually randomized group treatment trials. *Journal of Research on Educational Effectiveness*, 3, 381-405. doi: 10.1080/19345747.2010.504289

Whittington, M. S., & Raven, M. R. (1995). Learning and teaching styles of student teachers in the northwest. *Journal of Agricultural Education*, 36(4), 10-17. doi: 10.5032/jae.1995.04010

Wiersma, W., & Jurs, S. G. (1990). *Educational measurement and testing* (2nd ed.). Needham Heights, MA: Allyn and Bacon.

Wigfield, A. (1994). Expectancy-value theory of achievement motivation: A developmental perspective. *Educational Psychology Review*, 6(1), 49. doi: <http://dx.doi.org/10.1007/BF02209024>

- Wigfield, A., & Eccles, J. S. (1989). The development of achievement task values: A theoretical analysis, *Developmental Review*, 12, 265-310. doi: [http://dx.doi.org/10.1016/0273-2297\(92\)90011-P](http://dx.doi.org/10.1016/0273-2297(92)90011-P)
- Willcoxson, L. & Prosser, M. (1996). Kolb's learning style inventory (1985): Review and further study of validity and reliability. *British Journal of Educational Psychology*, 66, 247-257.
- Winch, C. (2010). Vocational education, knowing how and intelligence concepts. *Journal of Philosophy of Education*, 44(4), 552-567. doi: 10.1111/j.1467-9752.2010.00775.x
- Wirth, A. G. (1980). *Education in the technological society: The vocational-liberal studies controversy in the early twentieth century*. Washington, DC: University Press of America.
- Wurdinger, S. D. (2005). *Using experiential learning in the classroom*. Lanham, MD: Scarecrow Education.
- Yahya, I. (1998). Willcoxson and Prosser's factor analyses on Kolb's (1985) LSI data: reflections and re-analyses. *British Journal of Educational Psychology*, 68, 281-286.
- Young, R. B. (2006). *Effects of a math-enhanced curriculum and instructional approach on the performance of secondary education students enrolled in a year-long agricultural power and technology course: An experimental study*. (Doctoral dissertation). Retrieved from <http://search.proquest.com.argo.library.okstate.edu>

APPENDICES

APPENDIX A

INSTITUTIONAL REVIEW BOARD APPROVAL FORM

Oklahoma State University Institutional Review Board

Date: Wednesday, September 05, 2012
IRB Application No: AG1230
Proposal Title: The Effect of Kolb's Experiential Learning Model on Successful Student Intelligence and Student Motivation
Reviewed and Processed as: Expedited

Status Recommended by Reviewer(s): Approved Protocol Expires: 9/4/2013

Principal Investigator(s):

Marshall Baker	J. Shane Robinson
458 Ag Hall	457 Ag Hall
Stillwater, OK 74078	Stillwater, OK 74078

The IRB application referenced above has been approved. It is the judgment of the reviewers that the rights and welfare of individuals who may be asked to participate in this study will be respected, and that the research will be conducted in a manner consistent with the IRB requirements as outlined in section 45 CFR 46.

The final versions of any printed recruitment, consent and assent documents bearing the IRB approval stamp are attached to this letter. These are the versions that must be used during the study.

As Principal Investigator, it is your responsibility to do the following:

1. Conduct this study exactly as it has been approved. Any modifications to the research protocol must be submitted with the appropriate signatures for IRB approval. Protocol modifications requiring approval may include changes to the title, PI, advisor, funding status or sponsor, subject population composition or size, recruitment, inclusion/exclusion criteria, research site, research procedures and consent/assent process or forms.
2. Submit a request for continuation if the study extends beyond the approval period of one calendar year. This continuation must receive IRB review and approval before the research can continue.
3. Report any adverse events to the IRB Chair promptly. Adverse events are those which are unanticipated and impact the subjects during the course of this research; and
4. Notify the IRB office in writing when your research project is complete.

Please note that approved protocols are subject to monitoring by the IRB and that the IRB office has the authority to inspect research records associated with this protocol at any time. If you have questions about the IRB procedures or need any assistance from the Board, please contact Beth McTernan in 219 Cordell North (phone: 405-744-5700, beth.mcternan@okstate.edu).

Sincerely,

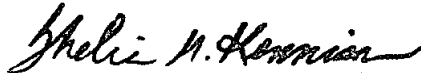

Shelia Kennison, Chair
Institutional Review Board

APPENDIX B
STILLWATER PUBLIC SCHOOLS INSTITUTIONAL REVIEW BOARD
APPROVAL FORM

STILLWATER BOARD OF EDUCATION

GVA-E

**RESEARCH STUDY REQUEST
STILLWATER PUBLIC SCHOOLS**

I hereby request permission to conduct a research study in the Stillwater Public Schools district during the period
September 10, 2012 to September 28, 2012.

The Effect of Kolb's Experiential Learning Model on Successful Student Intelligence and Student
Motivation
The topic is _____

Date Submitted August 29, 2012 Daytime Phone Number 405-385-4475

Reason for Request:

Class Requirement Master's Thesis Doctoral Dissertation Other

If this request is granted, I agree to abide by the Stillwater Board of Education policy and administrative procedures.

Marshall A. Baker
Typed Name of Researcher

Marshall A Baker
Signature of Researcher(s)

Oklahoma State University
Institution of Higher Education

Dept. of Agricultural Education
Sponsoring College or Department

Dr. J. Shane Robinson
Typed Name of Faculty Member

J. Shane Robinson
Signature of Faculty Member

Submit approval letter from the IRB
(Must have IRB approval to proceed.)

ENDORSEMENT:

This request was Approved Disapproved 9/4/12
(date)

Gay Washington
Assistant Superintendent or Designee

Adoption Date: August 11, 2009

Revision Date(s):

Page 1 of 3

RESEARCH STUDY REQUEST (Cont.)

**PROPOSAL FOR RESEARCH
STILLWATER PUBLIC SCHOOLS**

Purpose and Description of Study:

The purpose of the study is to empirically test the effect of curriculum based on Kolb's Experiential Learning Theory on students' creative, practical, and analytical skills as well as student motivation.

Number and Description of Students Required:

The sampling population includes all secondary agricultural education students in the Stillwater High School Agricultural Education program. This includes students in grades 10 - 12, and the demographics of the students are expected to mirror that of the normal student population in the secondary schools in this selected region.

Time Required of Each Student:

Time required will be four hours.

Time Required of Classroom Teacher:

Teachers will be required to assist in the instruction of wind energy curriculum for a total of four hours.

Information Needed from School Records:

Basic Information that is asked in the demographic sheet found in the IRB application

Include copies of any data-gathering instruments and permission forms:

See OSU IRB Application

Equipment and Materials to be Used.

Projector and computer in the agricultural education department

Facilities Needed:

Stillwater High School Agricultural Education Facility

Major Investigator:

Marshall A. Baker

Research Assistant:

None

RESEARCH STUDY REQUEST (Cont.)

Starting Date:
September 10, 2012

Finishing Date:
September 28, 2012

Preferred Days and Times for Collecting Data:
Times have been discussed with both Uwe Gordon and Agricultural Educators. September 18, from 8 until noon is the best time to collect the data.

Special Conditions and Restrictions:
None beyond those discussed in IRB application

Use of the Results:
Better inform the training of agricultural educators and building curriculum for the agricultural education department.

If the research includes data-gathering instruments or interview protocols, these must be submitted with the proposal, along with the parent permission form.

APPENDIX C
SCHOOL DISTRICT RESEARCH INFORMATION SHEET

School District Research Information Sheet
Experiential Learning Research Investigation

August 2012

Stillwater High School Agricultural Education Department has agreed to participate in a research study being conducted by the Agricultural Education, Communications and Leadership department at Oklahoma State University (OSU). This teacher was purposefully selected because of the pre-existing curriculum emphasis in the area of alternative energy. We ask that you sign this letter of consent indicating that you are informed about the study and support the teachers' participation in this project.

Background Information:

The purpose of the study is to empirically test the hypothesis that students who participate in an agricultural education course, built upon experiential learning principles, would develop both their creative, analytical, and practical skills as well as become more motivated to learn the subject.

Procedures: The following requirements have been identified as crucial to this study.

The teacher will:

- Coordinate the four-hour academic experience centered on wind energy that is already a part of the courses curriculum.
- Assist in delivering a STEM based experiential curriculum centered on wind energy.
- Assist in the administering of three assessments measuring student motivation, learning style, and performance.

Risks and Benefits:

There are no known risks associated with this project, which are greater than those ordinarily encountered in daily life. The results of this study will be useful to the Oklahoma FFA Association staff, Oklahoma agricultural education instructors, state agricultural education staff members, and other stakeholders who are interested in affecting program impact and in improving agricultural education by helping students succeed academically.

Confidentiality:

The records of this study will be kept private and any information obtained relating to you or your students will be kept confidential. Any reports that are generated as a result of this study will remain confidential as well, and not include any identifiers to you or your students. Since this is classified as a voluntary study, your decision to participate will have no bearing on your current or future relationship with OSU.

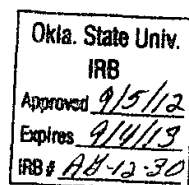

Updated: 8/20/2012

Contact Information:

If you have any questions now or in the future regarding this study, please do not hesitate to contact myself or the others listed below.

Marshall A. Baker
405-744-2972
bakerma@okstate.edu

Dr. Shane Robinson
405-744-3094
shane.robinson@okstate.edu

If you have questions about your rights as a research volunteer, you may contact the Oklahoma State University Institutional Review Board (IRB) Chair, Dr. Shelia Kennison at 219 Cordell North, Stillwater, OK 74078, 405-744-3377 or irb@okstate.edu.

Please retain a copy of this form for your records

Statement of Consent:

I have read the above information and support the participation of the teacher in this study.

Printed Name

Signature

Date

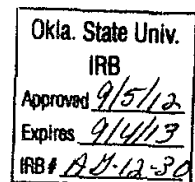

APPENDIX D
TEACHER RECRUITMENT SCRIPT

Teacher Recruitment Script

I am about to hand out a parental permission form and a student assent form related to a research project, led by staff at Oklahoma State University, on September 5th, 2012.

Alternative energy, especially wind energy, is a curriculum unit that is a part of this class you are in. We will spend a morning completing a learning experience where you design your own wind turbine and test how well it produces energy. Oklahoma State University is doing a study related to that type of school activity and has asked if you would participate. Participation would include:

1. a short instrument designed to determine the students' learning style,
2. a questionnaire designed to identify student characteristics such as age, grade in school, GPA, and gender,
3. a short test designed to measure what the student has learned about wind energy, and
4. an instrument that measures how motivated students are regarding the instruction at the academy.

These four items will be scored and used by OSU to better understand how you learn best. Your participation is completely voluntary, and it is not related to your grade in this class at all.

If you choose to participate, you will need to take one of the Parental Permission forms to your parents, have them read the whole thing, and then sign it if they agree to you participating. You then bring that back to me signed. Once again, you don't have to do this at all. It is your option. You will also sign an assent form the day of the experience if you still choose to participate.

Do you have any questions?

Pass out the parental consent/ permission forms to students who would like to participate. Go over the parental consent form in addition to this script to further describe the study.

Updated: 8/20/2012

Okla. State Univ. IRB Approved <u>9/5/12</u> Expires <u>9/4/13</u> IRB # <u>25-12-30</u>
--

APPENDIX E
PARENT/GUARDIAN PERMISSION FORM

**PARENT/GUARDIAN PERMISSION FORM
OKLAHOMA STATE UNIVERSITY**

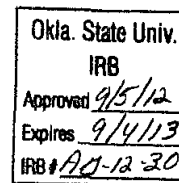

PROJECT TITLE: The Effect of Kolb's Experiential Learning Model on Successful Student Intelligence and Student Motivation.

INVESTIGATORS: Marshall A. Baker, M.S.; J. Shane Robinson, Ph.D., Oklahoma State University

PURPOSE:

The purpose of the study is to empirically test the hypothesis that students who participate in an agricultural education course, built upon experiential learning principles, would develop both their creative, analytical, and practical skills as well as become more motivated to learn the subject.

PROCEDURES:

Students in the Stillwater Agricultural Education Department will participate in a four hour, hands-on, wind energy experience that focuses on the science, technology, engineering and mathematics of wind energy as a standard part of the agricultural education curriculum. OSU will be conducting a research study in conjunction with this curriculum to understand how learning experiences, like the one your student will participate in, are effective in improving student performance and motivation.

Your student will be asked to complete four documents related to their wind energy curriculum; (1) a short instrument designed to determine the your child's learning style, (2) a questionnaire designed to identify student characteristics such as age, grade in school, GPA, and gender, and (3) a short test designed to measure what the student has learned about wind energy, and (4) an instrument that measures how motivated students are regarding the instruction at the academy. The four items above will take no longer than 60 minutes and they are incorporated into the learning process.

RISKS OF PARTICIPATION:

There are no known risks associated with this project, which are greater than those ordinarily encountered in daily life.

BENEFITS OF PARTICIPATION:

The results of this study will be useful to the Oklahoma FFA Association staff, Oklahoma agricultural education instructors, state agricultural education staff members, and other stakeholders who are interested in affecting program impact and in improving agricultural education by helping students succeed academically.

CONFIDENTIALITY:

The records of this study will be kept private. Any written results will discuss group findings and will not include information that will identify your child. Research records will be stored securely and only researchers and individuals responsible for research oversight will have access to the records. Subject names will not be used; instead, a researcher assigned number will identify participants. The researcher will create a temporary list linking participant names and researcher assigned ID numbers while data

collection is on going. This list will be kept in a locked file cabinet in a faculty office (Ag Hall 458) until May 2012 when it will be destroyed. The PI, Marshall A. Baker, and his advisor, J. Shane Robinson, will have access to the coded list. It is possible that the consent process and data collection will be observed by research oversight staff responsible for safeguarding the rights and wellbeing of people who participate in research.

CONTACTS:

Parents/Guardians may contact any of the researchers at the following addresses and phone numbers, should they desire to discuss their child's participation in the study and/or request information about the results of the study: Marshall A. Baker, M.S., 458 Agricultural Hall, Dept. of Agricultural Education, Communications and Leadership, Oklahoma State University, Stillwater, OK 74078, (405) 744-2972. If you have questions about your child's rights as a research volunteer, you may contact the Oklahoma State University Institutional Review Board (IRB) Chair, Dr. Shelia Kennison at 219 Cordell North, Stillwater, OK 74078, 405-744-3377 or irb@okstate.edu.

PARTICIPANT RIGHTS:

Your child's participation is voluntary, there is no penalty for their refusal to participate, and you are free to withdraw your permission at any time, without penalty.

CONSENT DOCUMENTATION:

I have been fully informed about the procedures listed here. I am aware of what my child and I will be asked to do and of the benefits of their participation.

I affirm that I am 18 years of age or older.

I have read and fully understand this consent form. I sign it freely and voluntarily. A copy of this form will be given to me. I hereby give permission for my child _____ (insert child name here) and my participation in this study.

Signature of Parent/Legal Guardian

Date

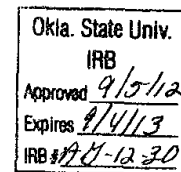

APPENDIX F
STUDENT ASSENT FORM

STUDENT ASSENT FORM

Dear Student,

We are interested in learning about experiential learning. The agricultural education class you are in includes a unit on alternative energy. You will be building your own wind turbines and testing how well they produce electricity. Researchers at OSU want to study how well this type of lesson helps you as a student. You will be asked to do four things related to the lesson:

1. Do a short instrument designed to determine the your learning style,
2. Give basic information about yourself,
3. Do a short test to measure what you learned about wind energy, and
4. Answer some questions about how interested you are in the subject.

Your parent/guardian knows about this project. You do not have to do this. You do not have to answer any questions that you do not want to. You may stop at any time and bring the forms back to me.

Your name will not be on the forms you fill out, and you will be given a number that will be put on your answer sheet so no one will know whose answers they are. If you have any questions about the form or what we are doing, please ask us. Thank you for your help.

Sincerely,

Marshall A. Baker
Graduate Student Oklahoma State University

J. Shane Robinson, Ph.D.
Professor Oklahoma State University

I have read this form and agree to help with your project.

(your name)

(your signature)

(date)

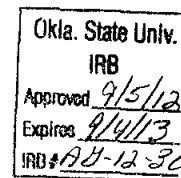

Updated: 8/20/2012

APPENDIX G
TEACHING ASSISTANT RECRUITMENT FLYER

Baker – Wind Energy Info Sheet

Where: Stillwater Church of Christ at 821 N. Duck

When: 5PM on Monday night for some training
7:45 AM – 3:00 PM on Tuesday for actual event

What: Wind Energy Academy for Stillwater High School Ag Ed. Students. It is also an experiment for doctoral research seeking to answer the question, “What are the effects of an experiential learning curriculum?”

Who: Well, you, Mr. Baker, Dr. Brown, Dr. Robinson and lots of fun high school students. Marshall Baker’s cell phone number is 405-385-4475 in case you have any questions.

I can’t say thanks enough! This should be a good time had by all! There is a special place in teacher heaven for those who volunteer!

APPENDIX H
ANALYTICAL PRETEST INSTRUMENT

What Do You Know Already?

Wind Energy Academy Pre-Test

Student #: _____ Name: _____

Directions: Read the question and select the **one** best answer from the four choices provided. Write your answer in the attached answer sheet provided.

- Which of the following factors has the most influence on power output?
 - Swept Area
 - Blade Length
 - Wind Velocity
 - Air Density
- Suppose you make a homemade wind turbine that has three blades that are one meter long each. You live at sea level so the air density is about 1.23 kilograms per meter cubed. The wind is blowing at 12 meters per second. Using the power equation, $P = \frac{1}{2} \rho AV^3$, what is the theoretical power output of the wind produced? Feel free to work out the problem on this test sheet.
 - 1,063 Watts
 - 3,337 Watts
 - 10,851 Watts
 - 50,667 Watts
- Most wind turbines capture approximately how much of the theoretical power you just calculated?
 - 5%
 - 40%
 - 75%
 - 95%
- There is a theoretical limit of how much wind can be captured and converted to energy. That limit is called what?
 - The Theoretical Limit
 - The Betz Limit
 - The Wind Wall Limit
 - Turbine Max Limit
- Torque is referring to what?
 - The force that turns or rotates something
 - How fast a blade turns
 - The amount of electrical power produced
 - The height of a wind turbine

6. Which label in the picture is pointing towards the nacelle?
 a. A
 b. B
 c. C
 d. D
7. Which label in the picture is pointing towards the tower?
 a. A
 b. B
 c. C
 d. D

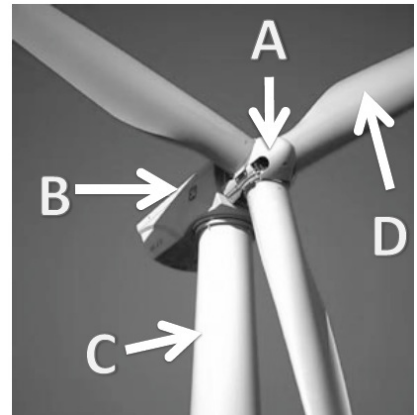

8. Which blade below has the highest solidity?

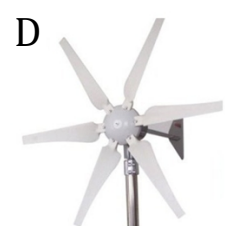
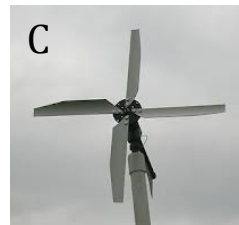
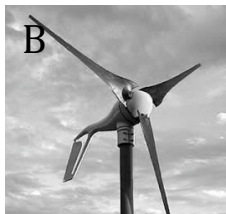

9. A wind turbine that has a high solidity should have
 a. High torque and high speed
 b. High torque and low speed
 c. Low torque and high speed
 d. Low torque and low speed
10. Which of the following is a major challenge for wind energy?
 a. Wind turbines often break in high winds.
 b. Wind turbines produce dangerous gases.
 c. Wind is not always a reliable resource.
 d. The power generated from wind energy is low quality.
11. Calculate the swept area of a turbine with 20 meter long blades (Hint: Swept area equation: $A = \pi r^2$).
 a. 867 m²
 b. 933 m²
 c. 1256 m²
 d. 1453 m²

12. What will happen to the voltage output if the pitch of the blades is changed from 10 degrees to 50 degrees?
- Voltage will go up
 - Voltage will go down
 - Voltage will not change
 - Voltage will become inconsistent
13. Where is the electrical power of a wind turbine produced?
- In the blades as they push through the wind
 - In the gears connected to the hub
 - In the base of the tower
 - In the generator housed in the nacelle
14. When a person refers to “wind resistance”, they are talking about what?
- Lift
 - Solidity
 - Torque
 - Drag
15. What would be the result of airfoil blades instead of flat blades?
- Less drag and less lift.
 - Less drag and more lift.
 - More drag and less lift.
 - More drag and more lift.
16. The picture is an example of what principle?
- Solidity
 - Swept Area
 - Wind Velocity
 - Betz Limit

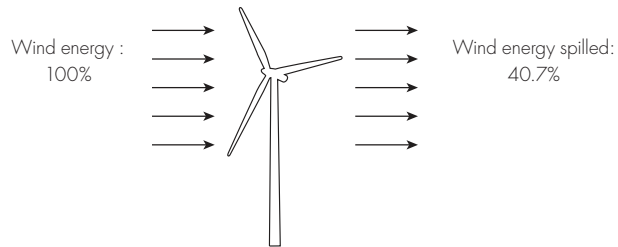

17. The angle of a blade in relation to the plane of rotation is referring to what?
- Blade length
 - Blade shape
 - Blade pitch
 - Blade solidity

18. A teardrop cross-section used for wind turbine blades to increase efficiency is known as what?
- a. Airfoil Design
 - b. Flat Blade Design
 - c. Tear Blades
 - d. Tapered Blades
19. If more blades were added to a turbine design, it would result in what?
- a. More voltage and less torque
 - b. Less voltage and more torque
 - c. More voltage and more torque
 - d. Less voltage and less torque
20. What would happen if blades were made longer so that the edges were no longer in the column of wind?
- a. The bigger blade would cause drag and increase voltage.
 - b. The bigger blade would cause drag and reduce voltage.
 - c. The bigger blade would create additional lift.
 - d. No change – the extra length in no wind is useless.
21. If the swept area of a wind turbine is 10,000 meters squared, and the blades have an area of 1,000 meters squared, what is the solidity?
- a. 5% or .05
 - b. 10% or .10
 - c. 15% or .15
 - d. 20% or .20
22. Which of the following is most likely the solidity of the windmill shown?
- a. .10 or 10%
 - b. .50 or 50%
 - c. .90 or 90%
 - d. 1.0 or 100%



23. What would happen to voltage if blade A was cut to look like blade B?

- a. Voltage would increase.
- b. Voltage would decrease.
- c. Voltage would remain the same.
- d. You cannot really know until you test it.

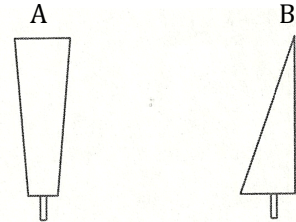

24. How does the airfoil design work?

- a. Air moves faster over the rounded side creating lift.
- b. Air molecules are split creating upward lift energy.
- c. Air hits the wind at an angle that is most efficient.
- d. Warmer air moves over the blade making it move faster.

Directions:

For questions 25-29, use the graphs below to answer the questions. Choose the one best answer and write that in the attached answer sheet.

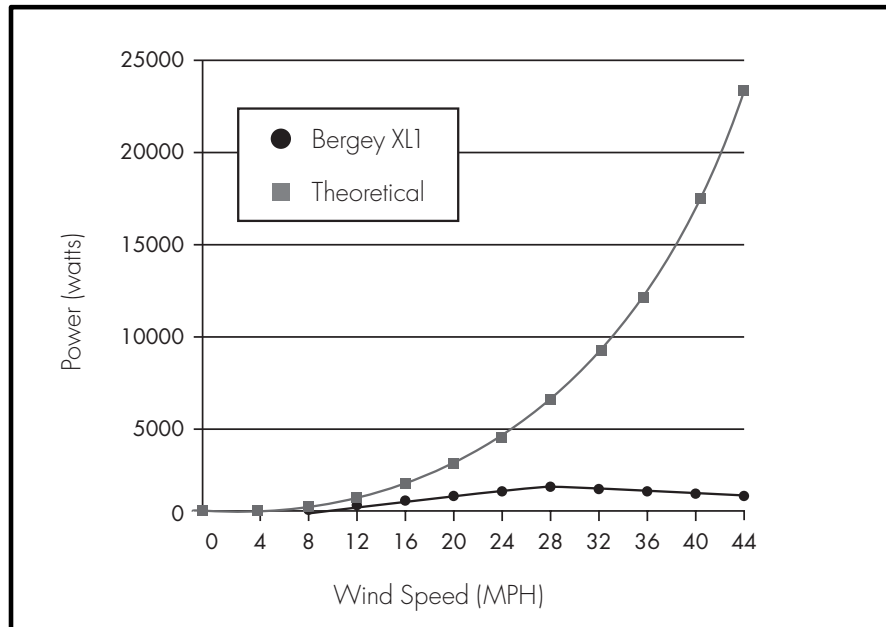

25. What are the variables of the two axes on this graph?

- a. Power and Wind Speed
- b. Bergey XL1 and Theoretical
- c. Bergey XL1 and Power
- d. Theoretical and Wind Speed

26. What does the theoretical line demonstrate regarding wind and power?
- As wind increases, so does power.
 - As wind increases, power does until a point where it stops.
 - As power increases, the wind decreases.
 - Wind and power are not very related.
27. At 28 MPH, how much power could be produced theoretically?
- 2,500 watts
 - 4,000 watts
 - 6,000 watts
 - 9,500 watts
28. How much power does the Bergey XL1 turbine actually produce at 28 MPH of wind?
- 1,200 watts
 - 3,200 watts
 - 5,200 watts
 - 7,200 watts
29. What is your conclusion about the Bergey XL1 based on the information presented in the graph?
- It is extremely efficient
 - It does not perform very well compared to typical turbines
 - It is about average
 - You cannot tell from this graph

Key Term Matching

Directions: Match the term to the correct definition. Record your answers in the attached answer sheet provided.

Word Bank

- | | |
|--|------------------|
| 30. This is the symbol for air density in the power equation | A. Wind Velocity |
| 31. The force associated with “wind resistance.” | B. Swept Area |
| 32. The angle of the blades with respect to the plane of rotation. | C. Hub |
| 33. The design that is similar to that of an airplane wing. | D. Drag |
| 34. The area of the circle created by turning blades known as A in the power equation. | E. ρ |
| 35. A way to explain how solid a turbine system is. | F. Solidity |
| 36. The part of the wind turbine that raises the turbine high enough. | G. Renewable |
| 37. The part of the wind turbine that holds the blades and rotates. | H. Tower |
| 38. The part of the power equation that has the most effect. | I. Pitch |
| 39. Wind energy is this kind of resource. | J. Airfoil |
| 40. The part of a turbine that catches wind and turns the rotor. | K. Blade |

Answer Sheet

Student Name: _____ Student Number: _____

Directions: Place your answers for each question in the space provided. **Please provide an answer for EVERY question. Thanks!**

- | | |
|-----------|-----------|
| 1. _____ | 21. _____ |
| 2. _____ | 22. _____ |
| 3. _____ | 23. _____ |
| 4. _____ | 24. _____ |
| 5. _____ | 25. _____ |
| 6. _____ | 26. _____ |
| 7. _____ | 27. _____ |
| 8. _____ | 28. _____ |
| 9. _____ | 29. _____ |
| 10. _____ | 30. _____ |
| 11. _____ | 31. _____ |
| 12. _____ | 32. _____ |
| 13. _____ | 33. _____ |
| 14. _____ | 34. _____ |
| 15. _____ | 35. _____ |
| 16. _____ | 36. _____ |
| 17. _____ | 37. _____ |
| 18. _____ | 38. _____ |
| 19. _____ | 39. _____ |
| 20. _____ | 40. _____ |

Answer Sheet KEY

Student Name: _____ Student Number: _____

Directions: Place your answers for each question in the space provided. **Please provide an answer for EVERY question. Thanks!**

- | | |
|-------|-------|
| 1. C | 21. B |
| 2. B | 22. A |
| 3. C | 23. A |
| 4. B | 24. A |
| 5. A | 25. A |
| 6. B | 26. A |
| 7. C | 27. C |
| 8. D | 28. A |
| 9. B | 29. B |
| 10. C | 30. E |
| 11. C | 31. D |
| 12. B | 32. I |
| 13. D | 33. J |
| 14. D | 34. B |
| 15. B | 35. F |
| 16. D | 36. H |
| 17. C | 37. C |
| 18. A | 38. A |
| 19. B | 39. G |
| 20. B | 40. K |

APPENDIX I
ANALYTICAL POSTTEST INSTRUMENT

What Did You Learn?

Wind Energy Academy Post-Test

Student #: _____ Name: _____

Directions: Read the question and select the **one** best answer from the four choices provided. Write your answer in the attached answer sheet provided.

- Which of the following factors has the most influence on power output?
 - Blade Length
 - Swept Area
 - Air Density
 - Wind Velocity
- Suppose you make a homemade wind turbine that has three blades that are one meter long each. You live at sea level so the air density is about 1.23 kilograms per meter cubed. The wind is blowing at 12 meters per second. Using the power equation, $P = \frac{1}{2} \rho AV^3$, what is the theoretical power output of the wind produced? Feel free to work out the problem on this test sheet.
 - 10,851 Watts
 - 1,063 Watts
 - 50,667 Watts
 - 3,336 Watts
- Most wind turbines capture approximately how much of the theoretical power you just calculated?
 - 95%
 - 75%
 - 40%
 - 5%
- There is a theoretical limit of how much wind can be captured and converted to energy. That limit is called what?
 - The Wind Wall Limit
 - The Betz Limit
 - The Theoretical Limit
 - Turbine Max Limit
- Torque is referring to what?
 - The amount of electrical power produced
 - How fast a blade turns
 - The height of a wind turbine
 - The force that turns or rotates something

6. Which label in the picture is pointing towards the nacelle?

- a. A
- b. B
- c. C
- d. D

7. Which label in the picture is pointing towards the tower?

- a. A
- b. B
- c. C
- d. D

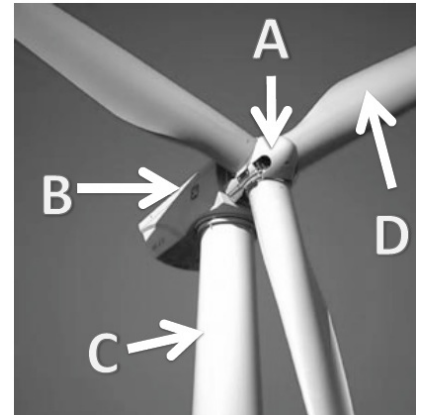

8. Which blade below has the highest solidity?

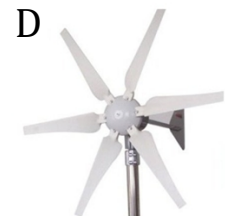
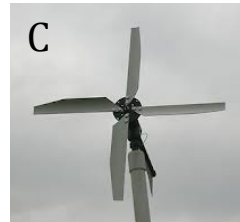
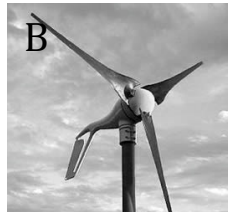

9. A wind turbine that has a high solidity should have

- a. Low torque and low speed
- b. Low torque and high speed
- c. High torque and high speed
- d. High torque and low speed

10. Which of the following is a major challenge for wind energy?

- a. The power generated from wind energy is low quality.
- b. Wind is not always a reliable resource.
- c. Wind turbines produce dangerous gases.
- d. Wind turbines often break in high winds.

11. Calculate the swept area of a turbine with 20 meter long blades (Hint: Swept area equation: $A = \pi r^2$).

- a. 867 m²
- b. 933 m²
- c. 1256 m²
- d. 1453 m²

12. What will happen to the voltage output if the pitch of the blades is changed from 10 degrees to 50 degrees?
- Voltage will become inconsistent
 - Voltage will not change
 - Voltage will go down
 - Voltage will go up
13. Where is the electrical power of a wind turbine produced?
- In the blades as they push through the wind
 - In the generator housed in the nacelle
 - In the gears connected to the hub
 - In the base of the tower
14. When a person refers to “wind resistance”, they are talking about what?
- Solidity
 - Lift
 - Drag
 - Torque
15. What would be the result of airfoil blades instead of flat blades?
- More drag and more lift.
 - More drag and less lift.
 - Less drag and less lift.
 - Less drag and more lift.
16. The picture is an example of what principle?
- Solidity
 - Betz Limit
 - Swept Area
 - Wind Velocity

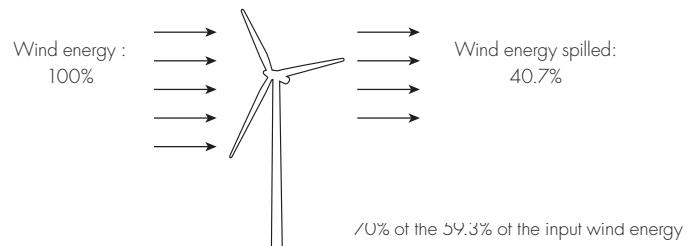

17. The angle of a blade in relation to the plane of rotation is referring to what?
- Blade solidity
 - Blade shape
 - Blade length
 - Blade pitch

18. A teardrop cross-section used for wind turbine blades to increase efficiency is known as what?
- a. Tapered Blades
 - b. Airfoil Design
 - c. Flat Blade Design
 - d. Tear Blades
19. If more blades were added to a turbine design, it would result in what?
- a. More voltage and more torque
 - b. Less voltage and less torque
 - c. More voltage and less torque
 - d. Less voltage and more torque
20. What would happen if blades were made longer so that the edges were no longer in the column of wind?
- a. No change – the extra length in no wind is useless.
 - b. The bigger blade would create additional lift.
 - c. The bigger blade would cause drag and increase voltage.
 - d. The bigger blade would cause drag and reduce voltage.
21. If the swept area of a wind turbine is 10,000 meters squared, and the blades have an area of 1,000 meters squared, what is the solidity?
- a. 5% or .05
 - b. 10% or .10
 - c. 15% or .15
 - d. 20% or .20
22. Which of the following is most likely the solidity of the windmill shown?
- a. .10 or 10%
 - b. .50 or 50%
 - c. .90 or 90%
 - d. 1.0 or 100%



23. What would happen to voltage if blade A was cut to look like blade B?

- a. You cannot really know until you test it.
- b. Voltage would remain the same.
- c. Voltage would increase.
- d. Voltage would decrease.

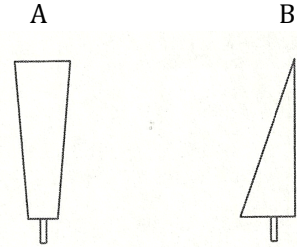

24. How does the airfoil design work?

- a. Warmer air moves over the blade making it move faster.
- b. Air molecules are split creating upward lift energy.
- c. Air moves faster over the rounded side creating lift.
- d. Air hits the wind at an angle that is most efficient.

Directions:

For questions 25-29, use the graphs below to answer the questions. Choose the one best answer and write that in the attached answer sheet.

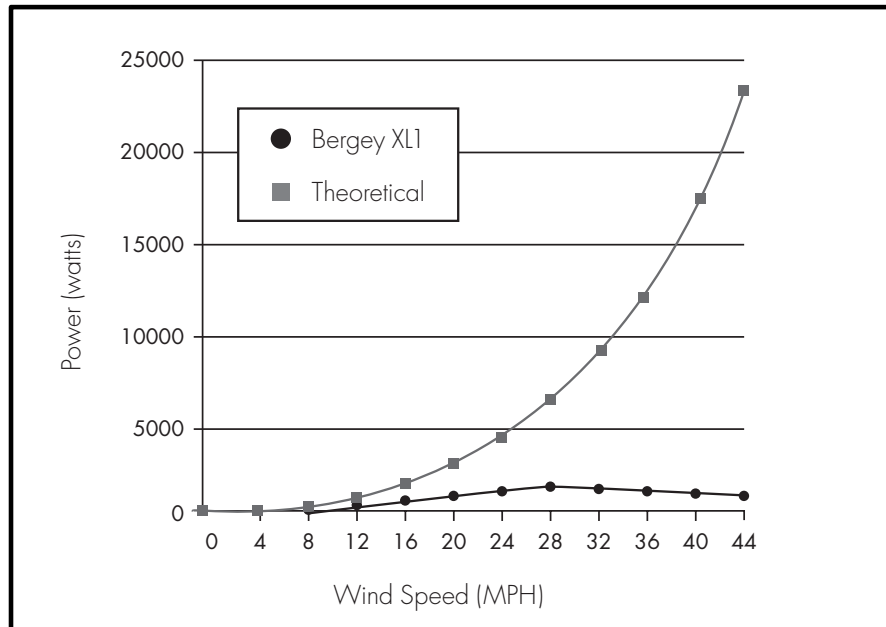

25. What are the variables of the two axes on this graph?

- a. Bergey XL1 and Power
- b. Power and Wind Speed
- c. Bergey XL1 and Theoretical
- d. Theoretical and Wind Speed

26. What does the theoretical line demonstrate regarding wind and power?
- a. Wind and power are not very related.
 - b. As wind increases, power does until a point where it stops.
 - c. As wind increases, so does power.
 - d. As power increases, the wind decreases.
27. At 28 MPH, how much power could be produced theoretically?
- a. 2,500 watts
 - b. 9,500 watts
 - c. 4,000 watts
 - d. 6,000 watts
28. How much power does the Bergey XL1 turbine actually produce at 28 MPH of wind?
- a. 7,200 watts
 - b. 5,200 watts
 - c. 3,200 watts
 - d. 1,200 watts
29. What is your conclusion about the Bergey XL1 based on the information presented in the graph?
- a. You cannot tell from this graph
 - b. It is about average
 - c. It is extremely efficient
 - d. It does not perform very well compared to typical turbines

Key Term Matching

Directions: Match the term to the correct definition. Record your answers in the attached answer sheet provided.

Word Bank

- | | |
|--|------------------|
| 30. This is the symbol for air density in the power equation | A. Wind Velocity |
| 31. The force associated with “wind resistance.” | B. Swept Area |
| 32. The angle of the blades with respect to the plane of rotation. | C. Hub |
| 33. The design that is similar to that of an airplane wing. | D. Drag |
| 34. The area of the circle created by turning blades known as A in the power equation. | E. ρ |
| 35. A way to explain how solid a turbine system is. | F. Solidity |
| 36. The part of the wind turbine that raises the turbine high enough. | G. Renewable |
| 37. The part of the wind turbine that holds the blades and rotates. | H. Tower |
| 38. The part of the power equation that has the most effect. | I. Pitch |
| 39. Wind energy is this kind of resource. | J. Airfoil |
| 40. The part of a turbine that catches wind and turns the rotor. | K. Blade |

Answer Sheet

Student Name: _____ Student Number: _____

Directions: Place your answers for each question in the space provided. **Please provide an answer for EVERY question. Thanks!**

- | | |
|-----------|-----------|
| 1. _____ | 21. _____ |
| 2. _____ | 22. _____ |
| 3. _____ | 23. _____ |
| 4. _____ | 24. _____ |
| 5. _____ | 25. _____ |
| 6. _____ | 26. _____ |
| 7. _____ | 27. _____ |
| 8. _____ | 28. _____ |
| 9. _____ | 29. _____ |
| 10. _____ | 30. _____ |
| 11. _____ | 31. _____ |
| 12. _____ | 32. _____ |
| 13. _____ | 33. _____ |
| 14. _____ | 34. _____ |
| 15. _____ | 35. _____ |
| 16. _____ | 36. _____ |
| 17. _____ | 37. _____ |
| 18. _____ | 38. _____ |
| 19. _____ | 39. _____ |
| 20. _____ | 40. _____ |

Answer Sheet

Student Name: _____ Student Number: _____

Directions: Place your answers for each question in the space provided. **Please provide an answer for EVERY question. Thanks!**

- | | |
|-------|-------|
| 1. D | 21. B |
| 2. D | 22. A |
| 3. B | 23. C |
| 4. B | 24. C |
| 5. D | 25. B |
| 6. B | 26. C |
| 7. C | 27. D |
| 8. D | 28. D |
| 9. D | 29. D |
| 10. B | 30. E |
| 11. C | 31. D |
| 12. C | 32. I |
| 13. B | 33. J |
| 14. C | 34. B |
| 15. D | 35. F |
| 16. B | 36. H |
| 17. D | 37. C |
| 18. B | 38. A |
| 19. D | 39. G |
| 20. D | 40. K |

APPENDIX J
ANALYTICAL DEFERRED POST TEST

What Do You Remember?

Wind Energy Academy

Student #: _____ Name: _____

Directions: Read the question and select the **one** best answer from the four choices provided. Write your answer in the attached answer sheet provided.

- Which of the following factors has the most influence on power output?
 - Swept Area
 - Blade Length
 - Wind Velocity
 - Air Density
- Suppose you make a homemade wind turbine that has three blades that are one meter long each. You live at sea level so the air density is about 1.23 kilograms per meter cubed. The wind is blowing at 12 meters per second. Using the power equation, $P = \frac{1}{2} \rho AV^3$, what is the theoretical power output of the wind produced? Feel free to work out the problem on this test sheet.
 - 1,063 Watts
 - 3,337 Watts
 - 10,851 Watts
 - 50,667 Watts
- Most wind turbines capture approximately how much of the theoretical power you just calculated?
 - 5%
 - 40%
 - 75%
 - 95%
- There is a theoretical limit of how much wind can be captured and converted to energy. That limit is called what?
 - The Theoretical Limit
 - The Betz Limit
 - The Wind Wall Limit
 - Turbine Max Limit
- Torque is referring to what?
 - The force that turns or rotates something
 - How fast a blade turns
 - The amount of electrical power produced
 - The height of a wind turbine

6. Which label in the picture is pointing towards the nacelle?

- a. A
- b. B
- c. C
- d. D

7. Which label in the picture is pointing towards the tower?

- a. A
- b. B
- c. C
- d. D

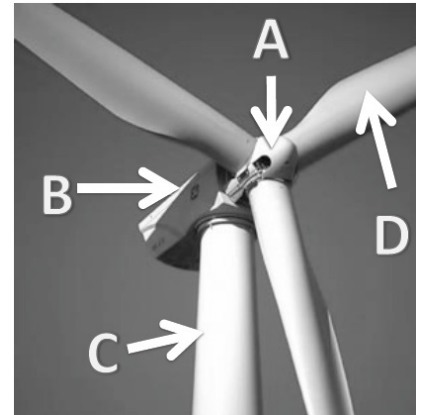

8. Which blade below has the highest solidity?

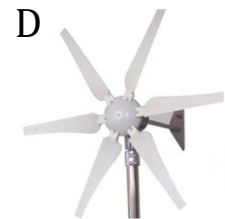
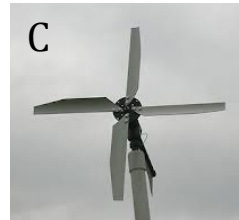
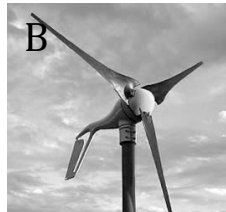

9. A wind turbine that has a high solidity should have

- a. High torque and high speed
- b. High torque and low speed
- c. Low torque and high speed
- d. Low torque and low speed

10. Which of the following is a major challenge for wind energy?

- a. Wind turbines often break in high winds.
- b. Wind turbines produce dangerous gases.
- c. Wind is not always a reliable resource.
- d. The power generated from wind energy is low quality.

11. Calculate the swept area of a turbine with 10 meter long blades (Hint: Swept area equation: $A = \pi r^2$).

- a. 3.14 m²
- b. 31.4 m²
- c. 314 m²
- d. 3140 m²

12. What will happen to the voltage output if the pitch of the blades is changed from 10 degrees to 50 degrees?
- Voltage will go up
 - Voltage will go down
 - Voltage will not change
 - Voltage will become inconsistent
13. Where is the electrical power of a wind turbine produced?
- In the blades as they push through the wind
 - In the gears connected to the hub
 - In the base of the tower
 - In the generator housed in the nacelle
14. When a person refers to “wind resistance”, they are talking about what?
- Lift
 - Solidity
 - Torque
 - Drag
15. What would be the result of airfoil blades instead of flat blades?
- Less drag and less lift.
 - Less drag and more lift.
 - More drag and less lift.
 - More drag and more lift.
16. The picture is an example of what principle?
- Solidity
 - Swept Area
 - Wind Velocity
 - Betz Limit

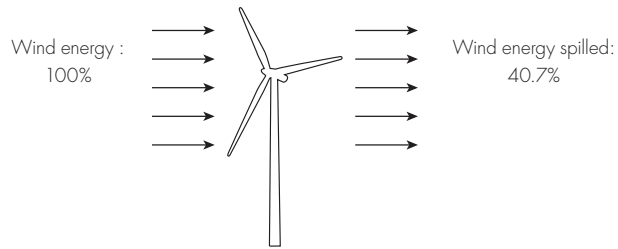

17. The angle of a blade in relation to the plane of rotation is referring to what?
- Blade length
 - Blade shape
 - Blade pitch
 - Blade solidity

18. A teardrop cross-section used for wind turbine blades to increase efficiency is known as what?
- a. Airfoil Design
 - b. Flat Blade Design
 - c. Tear Blades
 - d. Tapered Blades
19. If more blades were added to a turbine design, it would result in what?
- a. More voltage and less torque
 - b. Less voltage and more torque
 - c. More voltage and more torque
 - d. Less voltage and less torque
20. What would happen if blades were made longer so that the edges were no longer in the column of wind?
- a. The bigger blade would cause drag and increase voltage.
 - b. The bigger blade would cause drag and reduce voltage.
 - c. The bigger blade would create additional lift.
 - d. No change – the extra length in no wind is useless.
21. If the swept area of a wind turbine is 10,000 meters squared, and the blades have an area of 1,000 meters squared, what is the solidity?
- a. 5% or .05
 - b. 10% or .10
 - c. 15% or .15
 - d. 20% or .20
22. Which of the following is most likely the solidity of the windmill shown?
- a. .10 or 10%
 - b. .50 or 50%
 - c. .90 or 90%
 - d. 1.0 or 100%



23. What would happen to voltage if blade A was cut to look like blade B?

- a. Voltage would increase.
- b. Voltage would decrease.
- c. Voltage would remain the same.
- d. You cannot really know until you test it.

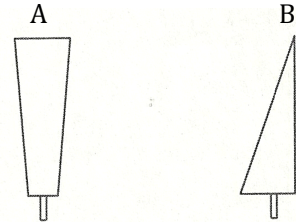

24. How does the airfoil design work?

- a. Air moves faster over the rounded side creating lift.
- b. Air molecules are split creating upward lift energy.
- c. Air hits the wind at an angle that is most efficient.
- d. Warmer air moves over the blade making it move faster.

Directions:

For questions 25-29, use the graphs below to answer the questions. Choose the one best answer and write that in the attached answer sheet.

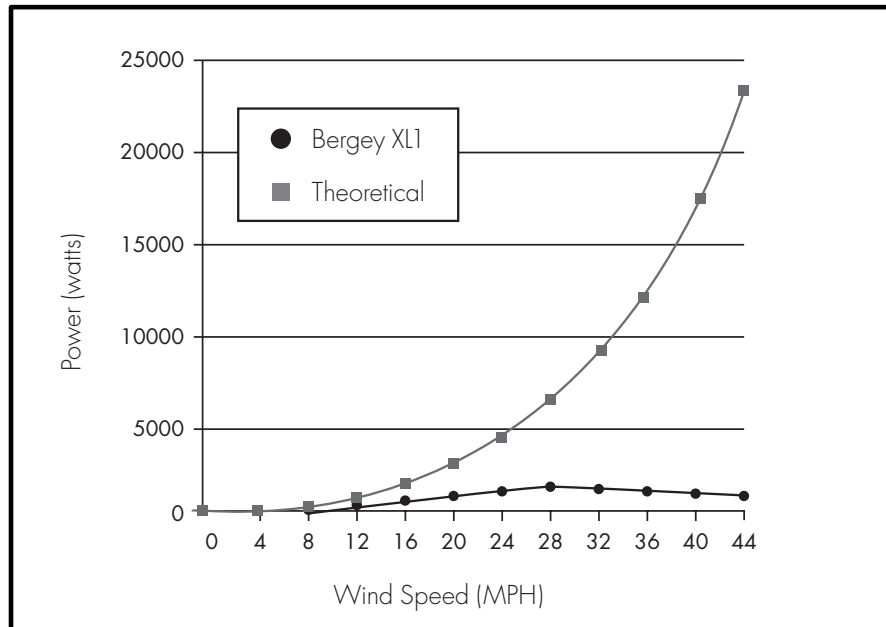

25. What are the variables of the two axes on this graph?

- a. Power and Wind Speed
- b. Bergey XL1 and Theoretical
- c. Bergey XL1 and Power
- d. Theoretical and Wind Speed

26. What does the theoretical line demonstrate regarding wind and power?
- As wind increases, so does power.
 - As wind increases, power does until a point where it stops.
 - As power increases, the wind decreases.
 - Wind and power are not very related.
27. At 28 MPH, how much power could be produced theoretically?
- 2,500 watts
 - 4,000 watts
 - 6,000 watts
 - 9,500 watts
28. How much power does the Bergey XL1 turbine actually produce at 28 MPH of wind?
- 1,200 watts
 - 3,200 watts
 - 5,200 watts
 - 7,200 watts
29. What is your conclusion about the Bergey XL1 based on the information presented in the graph?
- It is extremely efficient
 - It does not perform very well compared to typical turbines
 - It is about average
 - You cannot tell from this graph

Key Term Matching

Directions: Match the term to the correct definition. Record your answers in the attached answer sheet provided.

Word Bank

- | | |
|--|------------------|
| 30. This is the symbol for air density in the power equation | A. Wind Velocity |
| 31. The force associated with “wind resistance.” | B. Swept Area |
| 32. The angle of the blades with respect to the plane of rotation. | C. Hub |
| 33. The design that is similar to that of an airplane wing. | D. Drag |
| 34. The area of the circle created by turning blades known as A in the power equation. | E. ρ |
| 35. A way to explain how solid a turbine system is. | F. Solidity |
| 36. The part of the wind turbine that raises the turbine high enough. | G. Renewable |
| 37. The part of the wind turbine that holds the blades and rotates. | H. Tower |
| 38. The part of the power equation that has the most effect. | I. Pitch |
| 39. Wind energy is this kind of resource. | J. Airfoil |
| 40. The part of a turbine that catches wind and turns the rotor. | K. Blade |

Answer Sheet

Student Name: _____ Student Number: _____

Directions: Place your answers for each question in the space provided. **Please provide an answer for EVERY question. Thanks!**

- | | |
|-----------|-----------|
| 1. _____ | 21. _____ |
| 2. _____ | 22. _____ |
| 3. _____ | 23. _____ |
| 4. _____ | 24. _____ |
| 5. _____ | 25. _____ |
| 6. _____ | 26. _____ |
| 7. _____ | 27. _____ |
| 8. _____ | 28. _____ |
| 9. _____ | 29. _____ |
| 10. _____ | 30. _____ |
| 11. _____ | 31. _____ |
| 12. _____ | 32. _____ |
| 13. _____ | 33. _____ |
| 14. _____ | 34. _____ |
| 15. _____ | 35. _____ |
| 16. _____ | 36. _____ |
| 17. _____ | 37. _____ |
| 18. _____ | 38. _____ |
| 19. _____ | 39. _____ |
| 20. _____ | 40. _____ |

Answer Sheet KEY

Student Name: _____ Student Number: _____

Directions: Place your answers for each question in the space provided. **Please provide an answer for EVERY question. Thanks!**

- | | |
|-------|-------|
| 1. C | 21. B |
| 2. B | 22. A |
| 3. C | 23. A |
| 4. B | 24. A |
| 5. A | 25. A |
| 6. B | 26. A |
| 7. C | 27. C |
| 8. D | 28. A |
| 9. B | 29. B |
| 10. C | 30. E |
| 11. C | 31. D |
| 12. B | 32. I |
| 13. D | 33. J |
| 14. D | 34. B |
| 15. B | 35. F |
| 16. D | 36. H |
| 17. C | 37. C |
| 18. A | 38. A |
| 19. B | 39. G |
| 20. B | 40. K |

APPENDIX K

KOLB'S LEARNING STYLE INVENTORY (KLSI)

LEARNING-STYLE INVENTORY

The Learning-Style Inventory describes the way you learn and how you deal with ideas and day-to-day situations in your life. Below are 12 sentences with a choice of endings. Rank the endings for each sentence according to how well you think each one fits with how you would go about learning something. Try to recall some recent situations where you had to learn something new, perhaps in your job or at school. Then, using the spaces provided, rank a "4" for the sentence ending that describes how you learn *best*, down to a "1" for the sentence ending that seems least like the way you learn. Be sure to rank all the endings for each sentence unit. Please do not make ties.

Example of completed sentence set:

1. When I learn: 2 I am happy. 1 I am fast. 3 I am logical. 4 I am careful.

Remember: 4 = *most* like you 3 = *second most* like you 2 = *third most* like you 1 = *least* like you

	A	B	C	D
1. When I learn:	—	—	—	—
	I like to deal with	I like to think about	I like to be doing	I like to watch and

Note: Kolb's Learning Style Inventory was used through a grant funded by HayGroup®

and the full version can be purchased at: www.haygroup.com.

APPENDIX L
INSTRUCTIONAL MATERIALS MOTIVATION SURVEY (IMMS)

Student Name: _____ Student Number: _____

Instructions

Instructional Materials Motivation Survey

John M. Keller
Florida State University

1. There are 36 statements in this questionnaire. Please think about each statement in relation to the instructional materials you have just studied, and indicate how true it is. Give the answer that truly applies to you, and not what you would like to be true, or what you think others want to hear.
2. Think about each statement by itself and indicate how true it is. Do not be influenced by your answers to other statements.
3. Record your responses on the answer sheet that is provided, and follow any additional instructions that may be provided in regard to the answer sheet that is being used with this survey. Thank you.

- 1 (or A) = Not true
2 (or B) = Slightly true
3 (or C) = Moderately true
4 (or D) = Mostly true
5 (or E) = Very true

1. _____ When I first looked at this lesson, I had the impression that it would be easy for me.
2. _____ There was something interesting at the beginning of this lesson that got my attention.
3. _____ This material was more difficult to understand than I would like for it to be.
4. _____ After reading the introductory information, I felt confident that I knew what I was supposed to learn from this lesson.
5. _____ Completing the exercises in this lesson gave me a satisfying feeling of accomplishment.
6. _____ It is clear to me how the content of this material is related to things I already know.
7. _____ Many of the pages had so much information that it was hard to pick out and remember the important points.
8. _____ These materials are eye-catching.
9. _____ There were stories, pictures, or examples that showed me how this material could be important to some people.
10. _____ Completing this lesson successfully was important to me.
11. _____ The quality of the writing helped to hold my attention.
12. _____ This lesson is so abstract that it was hard to keep my attention on it.
13. _____ As I worked on this lesson, I was confident that I could learn the content.
14. _____ I enjoyed this lesson so much that I would like to know more about this topic.
15. _____ The pages of this lesson look dry and unappealing.
16. _____ The content of this material is relevant to my interests.
17. _____ The way the information is arranged on the pages helped keep my attention.
18. _____ There are explanations or examples of how people use the knowledge in this lesson.
19. _____ The exercises in this lesson were too difficult.
20. _____ This lesson has things that stimulated my curiosity.
21. _____ I really enjoyed studying this lesson.
22. _____ The amount of repetition in this lesson caused me to get bored sometimes.
23. _____ The content and style of writing in this lesson convey the impression that its content is worth knowing.
24. _____ I learned some things that were surprising or unexpected.
25. _____ After working on this lesson for awhile, I was confident that I would be able to pass a test on it.
26. _____ This lesson was not relevant to my needs because I already knew most of it.
27. _____ The wording of feedback after the exercises, or of other comments in this lesson, helped me feel rewarded for my effort.
28. _____ The variety of reading passages, exercises, illustrations, etc., helped keep my attention on the lesson.
29. _____ The style of writing is boring.
30. _____ I could relate the content of this lesson to things I have seen, done, or thought about in my own life.
31. _____ There are so many words on each page that it is irritating.
32. _____ It felt good to successfully complete this lesson.
33. _____ The content of this lesson will be useful to me.
34. _____ I could not really understand quite a bit of the material in this lesson.
35. _____ The good organization of the content helped me be confident that I would learn this material.
36. _____ It was a pleasure to work on such a well-designed lesson.

IMMS SCORING GUIDE

Attention	Relevance	Confidence	Satisfaction
2	6	1	5
8	9	3 (reverse)	14
11	10	4	21
12 (reverse)	16	7 (reverse)	27
15 (reverse)	18	13	32
17	23	19 (reverse)	36
20	26 (reverse)	25	
22 (reverse)	30	34 (reverse)	
24	33	35	
28			
29 (reverse)			
31 (reverse)			

APPENDIX M
WIND TURBINE DESIGN PLAN

Wind Turbine Design Plan

Student Name: _____ Student #: _____

In the space below, draw a detailed design of your proposed wind turbine. This design is a commitment to what you will build so take your time to get it right!

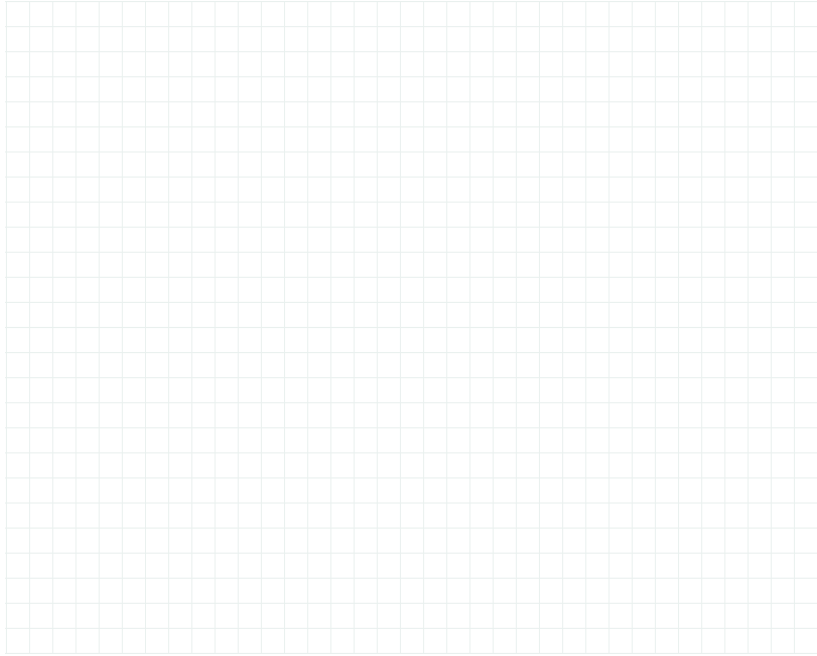

Describe the materials you will use to create your wind blade design. Be specific because this plan has to be shown to get supplies.

Give a detailed description explaining why you chose the design you chose. Be specific and use the ideas you learned about during the morning sessions. This has to be filled out to get supplies.

APPENDIX N
CREATIVITY SCORING GUIDE

CREATIVITY SCORING RUBRICS

CREATIVITY LENGTH SCORING GUIDE

1	Length of the original blade provided
2	~ $\frac{3}{4}$ of the original blade provided
3	~ $\frac{1}{2}$ of the original blade provided
4	~ $\frac{1}{4}$ of the original blade provided

CREATIVITY NUMBER OF BLADES SCORING GUIDE

1	1 blade used
2	2 blades used
3	3 blades used
4	4 blades used
5	5 blades used
6	6 blades used

CREATIVITY PITCH SCORING GUIDE

1	< 10 degree pitch
2	10 - 20 degree pitch
3	> 20 degree pitch
4	Varied pitch



















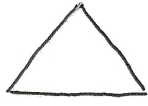

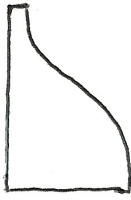

CREATIVITY ELABORATION BONUS

1	Unique elaboration present
0	No unique elaboration present

CREATIVITY MATERIAL SCORING GUIDE

1	Balsa Wood Airfoil Blades
2	Plastic Blades
3	Cardboard Blades
4	Kitchen Product Blades
5	Duct Tape

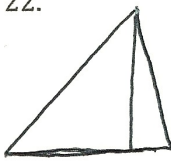
CREATIVITY SHAPE SCORING GUIDE

1. 	2. 	3. 	4. 
5. 	6. 	7. 	8. 
9. 	10. 	11. 	12. 
13. 	14. 	15. 	16. 
17. 	18. 	19. 	20. 
21. 	22. 	23. 	

APPENDIX O
EDUCATIONAL OBJECTIVES FOR WIND ENERGY UNIT

Objectives for Wind Energy Unit

Introduction to Wind Energy

Students will be able to...

1. Identify benefits and limitations of generating electricity from wind power

Basics of the Wind Turbine

Students will be able to...

2. Correctly identify 4 primary components of a wind turbine (blades, hub, nacelle, tower)

Wind Power Equation

Students will be able to...

3. Identify the 3 variables used to calculate available power in the wind (air density, turbine swept area, wind speed)
4. Identify which of these three variables has the greatest effect on turbine power output
5. Understand that there is a *theoretical maximum* percentage of the available power a turbine could extract from the wind called the Betz Limit.

Swept Area

Students will be able to...

6. Correctly calculate the swept area given various blade lengths.
7. Understand the role that swept area plays in determining how much power is available in a column of wind
8. Understand that longer blades give more swept area, but may also spin slower

Solidity

Students will be able to...

9. Understand the concept of solidity and how it is calculated
10. Be able to calculate rotor solidity with given input variables (swept area and rotor area)
11. Given two different rotor configurations (one high solidity, one low), identify which rotor would generate more torque and which would spin at higher RPM

Blade Variables

Students will be able to...

12. Predict what will happen to the voltage of a wind turbine if the **blade pitch** is changed from 10 degrees to 45 degrees (all other variables constant)
13. Predict what will happen to the voltage of a wind turbine if the **number of blades** is changed from 3 blades to 6 blades
14. Predict what will happen to the voltage of a wind turbine if the **length of blades...**

15. Predict what will happen to the voltage of a wind turbine with **wide rectangle shape blades vs. tapered blade shape blades...**
16. Predict what will happen to the voltage of a wind turbine using blades with **airfoil profile shape** (airfoil on downwind side) compared to flat plate blades

Lift and Drag

Students will be able to...

17. Understand how drag affects a wind turbine blade as it rotates through the air
18. Understand that the principle of lift makes turbine blades more efficient
19. Understand how a wind turbine blade uses an airfoil profile shape to generate lift

Data Collection and Analysis

Students will be able to...

20. Draw meaning from various types of charts and graphs.
21. Understand that voltage is directly related to generator RPM

APPENDIX P
EXPERIENTIAL LEARNING INSTRUCTIONAL MATERIALS

Wind Energy Experiential Learning Treatment Lesson Plan

Key Components to the Experiential Learning Technique

- Provide Concrete Experiences related to the learning goals of interest.
- Instructor serves as a facilitator throughout the concrete experience.
- The instructor is present and is actively guiding students throughout the experience.
- Purposeful reflection is achieved through questions that are prepared and asked at just the right time.
- The instructor serves as an expert as students reflect and create theories.
- Students are encouraged to identify abstract concepts based on their experience.
- Instructors provide evaluative feedback as students begin to use their abstract concepts in new ways.
- Students are provided opportunities for active experimentation, which can also be known as academic play.
- Instructors coach learners as they move from active experimentation to the next experience.
- Students should be driving instruction, supported by the instructor.
- Instructors are very familiar with the learning goals and are competent in the content of interest.

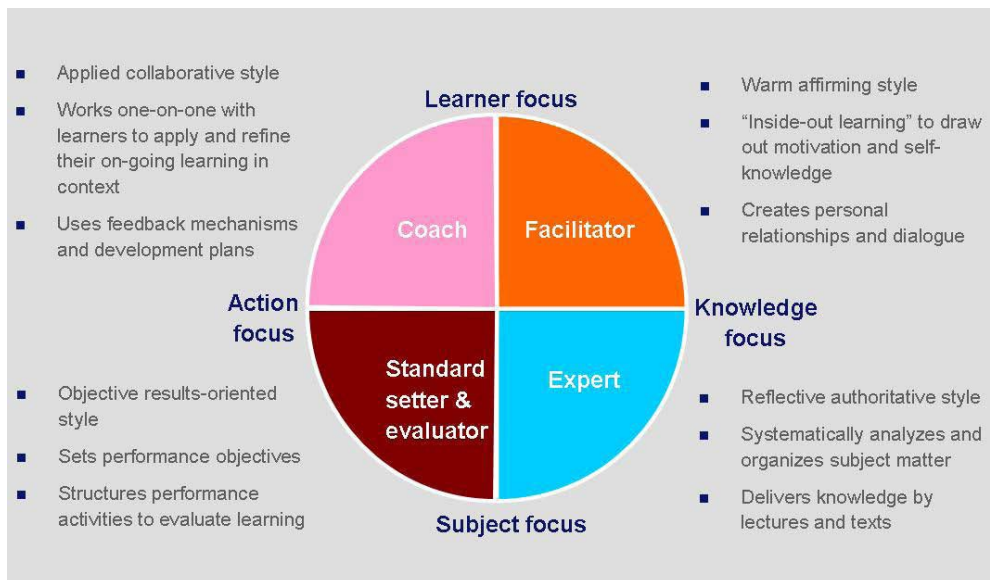

IDENTIFICATION

INSTRUCTOR: Dr. Nicholas R. Brown _____
 UNIT TOPIC: Wind Energy – Basic Blade Design _____
 LESSON TITLE: Blade Variables _____
 CLASS: ELT Treatment Group ____ DATE TAUGHT 9/18/2012 _____
 METHOD: Experiential TIME: 45 minutes

TEACHING MATERIALS AND RESOURCES

- Model Blade Setups
- Power Point Slides
- Worksheets 1.1 – 1.3

Learning Goals

Students will be able to...

Introduction to Wind Energy

Students will be able to...

1. Identify benefits and limitations of generating electricity from wind power

Basics of the Wind Turbine

Students will be able to...

2. Correctly identify 4 primary components of a wind turbine (blades, hub, nacelle, tower)

Wind Power Equation

Students will be able to...

3. Identify the 3 variables used to calculate available power in the wind (air density, turbine swept area, wind speed)
4. Identify which of these three variables has the greatest effect on turbine power output
5. Understand that there is a *theoretical maximum* percentage of the available power a turbine could extract from the wind called the Betz Limit.

Swept Area

Students will be able to...

6. Correctly calculate the swept area given various blade lengths.
7. Understand the role that swept area plays in determining how much power is available in a column of wind
8. Understand that longer blades give more swept area, but may also spin slower

Solidity

Students will be able to...

9. Understand the concept of solidity and how it is calculated
10. Be able to calculate rotor solidity with given input variables (swept area and rotor area)
11. Given two different rotor configurations (one high solidity, one low), identify which rotor would generate more torque and which would spin at higher RPM

Blade Variables

Students will be able to...

12. Predict what will happen to the voltage of a wind turbine if the **blade pitch** is changed from 10 degrees to 45 degrees (all other variables constant)
13. Predict what will happen to the voltage of a wind turbine if the **number of blades** is changed from 3 blades to 6 blades
14. Predict what will happen to the voltage of a wind turbine if the **length of blades...**
15. Predict what will happen to the voltage of a wind turbine with **wide rectangle shape blades vs. tapered blade shape blades...**
16. Predict what will happen to the voltage of a wind turbine using blades with **airfoil profile shape** (airfoil on downwind side) compared to flat plate blades

Lift and Drag

Students will be able to...

17. Understand how drag affects a wind turbine blade as it rotates through the air
18. Understand that the principle of lift makes turbine blades more efficient
19. Understand how a wind turbine blade uses an airfoil profile shape to generate lift

Data Collection and Analysis

Students will be able to...

20. Draw meaning from various types of charts and graphs.
21. Understand that voltage is directly related to generator RPM

Preparation

Prior to students entering the classroom, have the six stations setup around the room. Ensure that the reflection and abstraction sheets are also placed at each table.

Link:

Utilize the power point provided to set context of the experience.

Quickly go over the goals of the day. Let students ask questions to clarify and set the context of the day.

We're glad you're here this morning. How many of you have seen one of these around Oklahoma? Hold up a wind model wind turbine. We all probably have.

Have a discussion with the students about the various graphs relating wind energy to their personal experiences in Oklahoma with wind energy.

What is our goal?

- This afternoon, each of you will be creating your own wind turbine based on what you learn today.
- The person that designs the wind turbine that produces the most power – will be taking home the golden wind turbine and a nice little prize – and bragging rights!
- Three morning sessions to prepare!

Where does electricity come from?

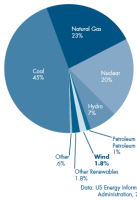

Data: US Energy Information Administration, 2009

Greenhouse gas emissions intensity by electrical generation type.

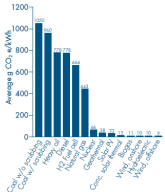

Installed wind capacity by state (megawatts)

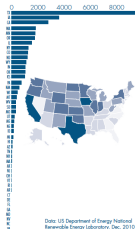

Data: US Department of Energy National Renewable Energy Laboratory, Dec. 2010

Wind Energy

Benefits	Drawbacks
<ul style="list-style-type: none"> Reduces negative environmental impacts to air, water, and wildlife. Reduces carbon pumped into the atmosphere. It is becoming cheaper. Using renewable resource to produce energy. 	<ul style="list-style-type: none"> Technology is being developed, but not perfect yet. Wind is not reliable. Moving energy produced on wind farms to urban areas where it is needed. Landscape Impact Sound – they are noisy! Cheap fossil fuels are tough competition.

Concrete Experience

Teacher Role:

It is important that the instructors act as FACILITATORS during this experience. Be present at the stations as possible.

Students will interact with the seven different tables that will be set up with a unique wind energy experience at each table. Students do not have to move in organized groups, but should make their way to each of the stations. This is a *sensory* experience – have students changing the fan speed, moving the blades, adjusting the turbines, etc.

Utilizing the KidWind Curriculum Guides, setup the seven tables as follows:

1. Two wind turbines are set up with varying pitches. Students can manipulate the pitch and vary the wind speed to interact with the effects of those changes and variables.
2. Two wind turbines are set up with varying blade lengths. Ensure students can manipulate the fan in order to test varying elements of drag.
3. Solidity KidWind systems setup so that students can see the differences between torque and blade speed when solidity is changed.
4. Two wind turbines with one utilizing airfoil blades and one flat blades. Have the fan available and able to be manipulated.
5. Two wind turbines with varying blade numbers – one with two and one with six. Have a fan for students to adjust and alter the wind.
6. Two wind turbines with various blade shapes available for students to interchange. Have a fan so they can also test these varying designs.

Ensure that students find their way to each of the stations and spend adequate time at each. They can go back to any of the stations they would like and there is no set time they must be at any given station.

At each station, make sure students take the reflection sheets and utilize that while at the station. On the back of the reflection sheets are abstract concepts that meet each of the objectives set out by the lesson. Direct kids to these resources as you facilitate and provide expert advice.

Reflective Observation

Teachers Role:

While students are interacting with the wind turbine stations, your role is to FACILITATE student thought about each of the stations and begin to guide as an EXPERT of this content. Use the base questions on each reflection sheet to engage in conversation gently guiding students towards the abstract concepts of interest for the objectives of the course.

Key Questions:

What is happening with these specific turbines?

What can you learn from this station as you think about building your own turbine?

Draw students to these questions and help facilitate their answers. Ensure students spend some time thinking about the questions and capturing those ideas on the reflection sheet.

As students think about the stations, encourage them to begin looking at some of the theory behind the six stations related to STEM concepts related to blade design. Help students start to make the connections and draw conclusions/theories about what they have experienced.

These reflections will be utilized during the next phase as we tie key concepts to their thoughts.

Resources:

Utilize the student reflection sheets located at each station.

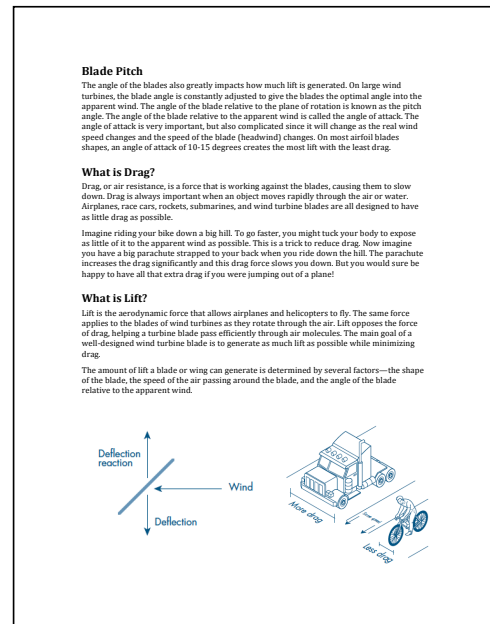
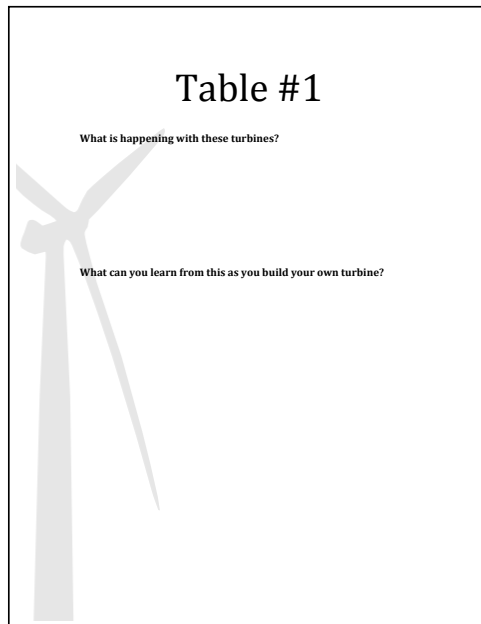

Experiential #2 Page 5

Abstract Conceptualization

Teacher Role:

Now that students have interacted with the six tables and have reflected on what is occurring at each station, it is time to begin serving as an EXPERT.

During this phase of the instruction, you will take a more instructor based approach. Get students together and have them bring their reflection sheets for each blade design station.

The goal of this time is to use your expertise to help students begin to develop overall theories that are based on their experiences at the stations. Guide students to the concepts on the back of each of the reflection sheets. Ensure that students read and discuss each of the six abstraction guides to be exposed to the critical information related to blade design and the course objectives. Feel free to use the board to teach various concepts that students are struggling with, and engage in conversations about how the abstract concepts relate to their observations.

Resources:

There is an abstraction sheet connected to each of the tables and reflection guides. These are your “text books” for this curriculum.

Active Experimentation

Teacher Role:

During this phase of instruction, students should have a chance to experience “academic play.” This means there are no real guidelines beyond that of basic respect and classroom expectations. Your role as the instructor is to be an EVALUATOR. Check the work of students as they test their ideas. Give feedback. Be present. Be knowledgeable. Challenge their thoughts and designs.

Set up the expectation that students have all the freedom to test their theories with the materials provided. The expectation is that students are focused on the task at hand.

Set up stations for the hot glue and the box knives to ensure student safety.

Resources:

Students have access to the following:

- Kid Wind bases with volt meters
- Fans
- Blade hubs
- Dowel rods for blade connection to hubs.
- Cardboard
- Plates
- Cups
- Duct Tape
- Bowls
- Poster board
- Foam board
- Hot glue guns
- Box knives
- Pitch Protractors

Be present as students build to keep them on task and challenged!

Lesson Closure

Teacher Role:

Bring closure to the lesson. Have a ten-minute discussion regarding what students have taken from the day. Return to the power point slides discussed earlier and ask if they view wind energy any different.

You may also ask how they see wind turbines and blades differently now?

Have students help clean the stations, and dismiss.

*** This curriculum is an adapted version of KidWind Project ®, and WindWise Education materials.**

Table #1

What is happening with these turbines?

What can you learn from this as you build your own turbine?



Blade Pitch

The angle of the blades also greatly impacts how much lift is generated. On large wind turbines, the blade angle is constantly adjusted to give the blades the optimal angle into the apparent wind. The angle of the blade relative to the plane of rotation is known as the pitch angle. The angle of the blade relative to the apparent wind is called the angle of attack. The angle of attack is very important, but also complicated since it will change as the real wind speed changes and the speed of the blade (headwind) changes. On most airfoil blades shapes, an angle of attack of 10-15 degrees creates the most lift with the least drag.

What is Drag?

Drag, or air resistance, is a force that is working against the blades, causing them to slow down. Drag is always important when an object moves rapidly through the air or water. Airplanes, race cars, rockets, submarines, and wind turbine blades are all designed to have as little drag as possible.

Imagine riding your bike down a big hill. To go faster, you might tuck your body to expose as little of it to the apparent wind as possible. This is a trick to reduce drag. Now imagine you have a big parachute strapped to your back when you ride down the hill. The parachute increases the drag significantly and this drag force slows you down. But you would sure be happy to have all that extra drag if you were jumping out of a plane!

What is Lift?

Lift is the aerodynamic force that allows airplanes and helicopters to fly. The same force applies to the blades of wind turbines as they rotate through the air. Lift opposes the force of drag, helping a turbine blade pass efficiently through air molecules. The main goal of a well-designed wind turbine blade is to generate as much lift as possible while minimizing drag.

The amount of lift a blade or wing can generate is determined by several factors—the shape of the blade, the speed of the air passing around the blade, and the angle of the blade relative to the apparent wind.

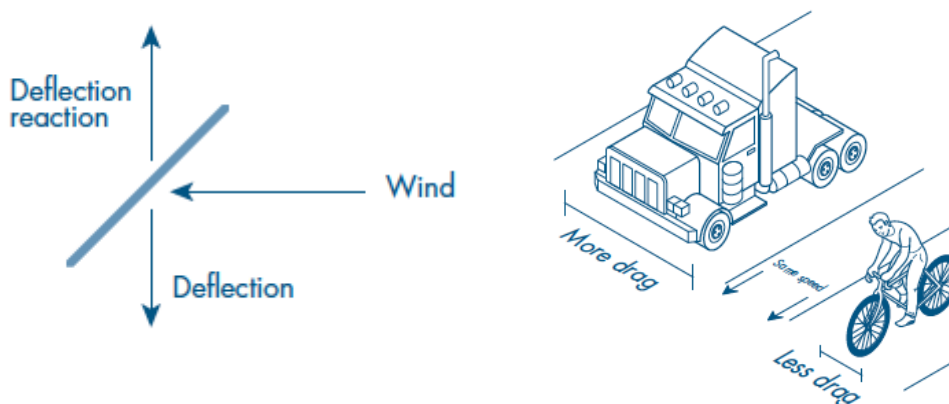

Table #2

What is happening with these turbines?

What can you learn from this as you build your own turbine?



Shape

The airfoil shape of the blade helps to generate lift by taking advantage of the Bernoulli Effect. Wind turbine blade designers have experimented with many different airfoil shapes over the years in an effort to find the perfect shape that will perform well in a range of wind speeds. Even minor changes in this blade shape can dramatically affect the power output and noise produced by a wind turbine. To get some ideas of different airfoils used in airplane wings and wind turbine blades, research the United States National Advisory Committee for Aeronautics (NACA). This group was responsible for designing a wide range of airfoils in the 1940's.

The airfoil profile (shape) of a turbine blade will actually change down the length of the blade, generally getting flatter and narrower toward the tips of the blades. This is to optimize the lift and minimize drag.

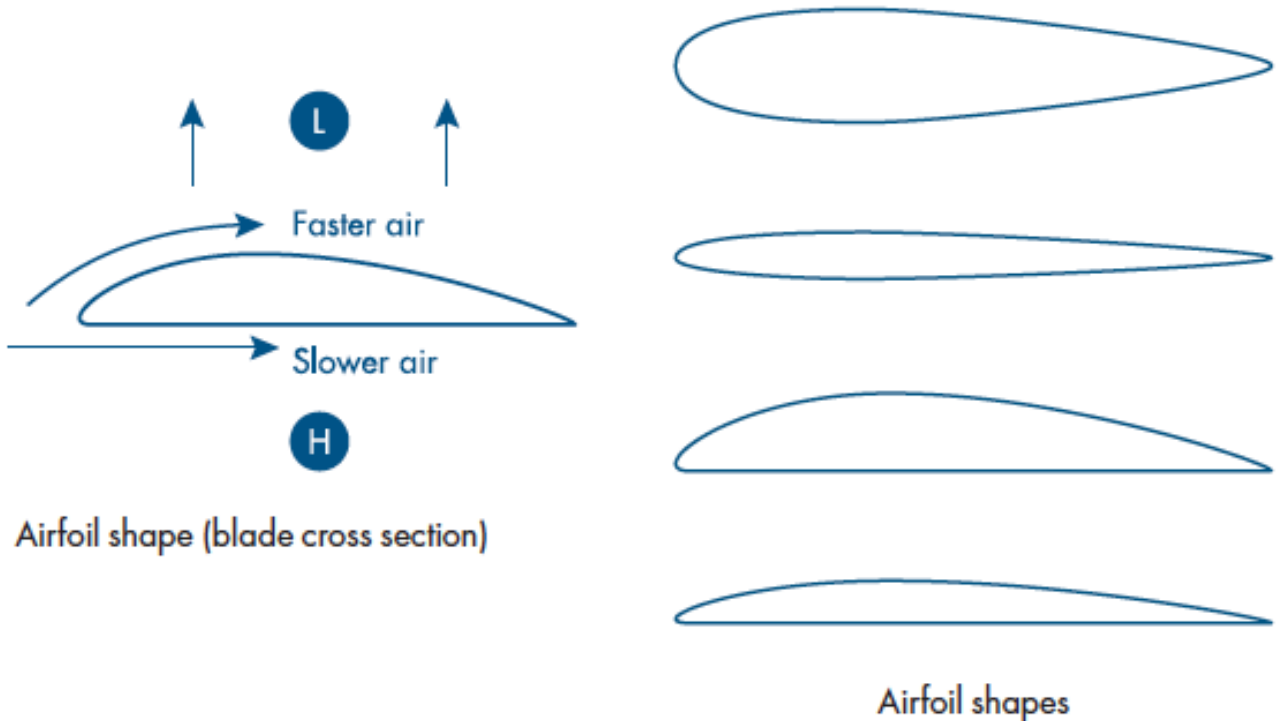

Table #3

What is happening with these turbines?

What can you learn from this as you build your own turbine?



Size of the Blades

So many times people think that the bigger the blade, the faster the blades will turn. This is sometimes true, but it is very hard to make longer blades that don't add more **drag** than **lift**.

For example, look below. If the blades are bigger than the fan, there are areas of the blade that are only adding resistance because there is no wind to add lift. This slows the blades down.

Remember, the key is to get as much of the energy in the wind into the blades to turn the generator and cause an increase in voltage!

Bigger isn't always better in wind energy folks.

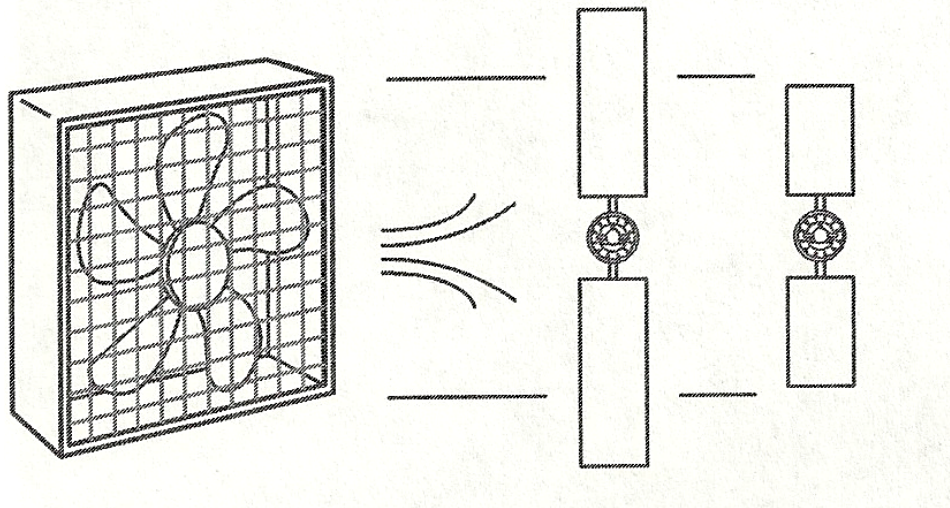

Table #4

What is happening with these turbines?

What can you learn from this as you build your own turbine?



Number of Blades

The more blades we add, the more drag we create. However, this drag also creates a lot of **TORQUE**. Like we said, it is a delicate balance between lift and drag. More blades does **SLOW DOWN** the **BLADE SPEED**, but **INCREASES THE TORQUE!**

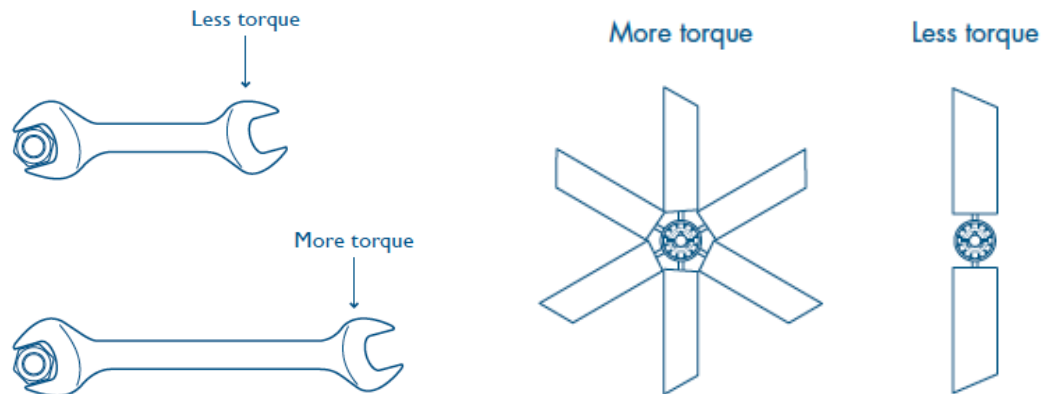

Calculating Solidity is an important concept. **Solidity** is basically the percentage of the swept area that is covered with a blade. Look below for the equation. You calculate the total area of the blades and divide it by the swept area. It is answering the question, "How **SOLID** is the swept area because it is filled with blades?"

Rotor Solidity

Solidity is the ratio of total rotor planform area to total swept area

Low solidity (0.10) = high speed, low torque



High solidity (>0.80) = low speed, high torque

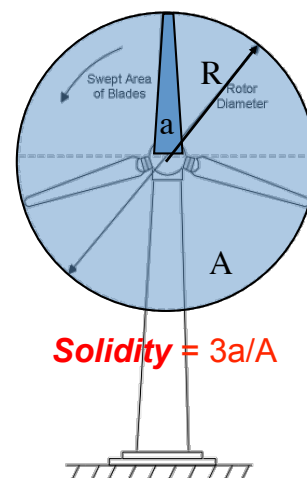

Table #5

What is happening with these turbines?

What can you learn from this as you build your own turbine?



Blade Design - Shaping the Blades

Once again - it is all about drag and lift. The tip of a blade travels much faster than the part of the blade close to the hub. A **tapered blade**, like the one on the right, causes less drag as it moves through the air, which increases blade speed and thus voltage!

It is also important to remember that poorly made blades can cause drag because of the rough design and items that cause drag. It is important to think about creating blades that move through the air with little wind resistance or drag.

More drag

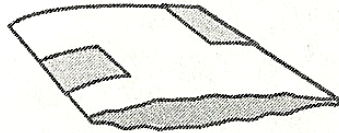

Less drag



Table #6

What is happening with these turbines?

What can you learn from this as you build your own turbine?



The Power Equation and the Betz Limit

If you have been doing some research on wind turbines, you may have come across a term called the Betz limit.

Wind turbines are limited on how much power they can capture from the wind. These limits can be caused by generator efficiencies, blade design, friction in the drive train, but most importantly wind flow through and around the wind turbine. A wind turbine cannot capture 100% of the power in the wind, because that would mean that the wind would have to be stopped completely. For a turbine to work properly, some wind has to move out the back of the wind turbine and keep the blade spinning.

Albert Betz calculated that a perfect turbine could only extract 59.3% of power in the wind stream, and we now call this number the Betz limit.

Wind Turbine Diagram

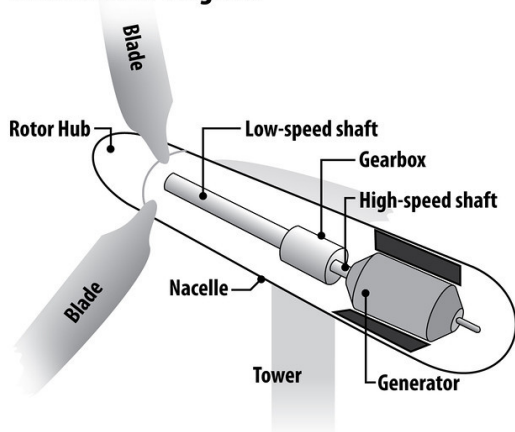

BETZ LIMIT IN PRACTICE

We have calculated the typical power in the wind coming from a box fan you may have around your house. We can compare that to how much power your turbine is producing to calculate your efficiency.

$$\text{Power in the wind} = \frac{1}{2} \rho (\pi r^2) v^3$$

$$V = 5 \text{ meters/second (typical fan output)}$$

$$\rho \text{ (air density)} = 1.0 \text{ kilograms/cubic meter}$$

$$r = .2 \text{ meters}$$

$$A = .125 \text{ m}^2 \text{ (area of circle} = \pi r^2)$$

$$= (.5)(1.0)(.125)(5)^3$$

$$= 7.85 \text{ watts}$$

Based on these calculations there are 7.85 watts of available wind power coming out of a typical house fan on high.

Based on the Betz limit the best turbine we can produce will only capture is 4.65 watts ($7.85 \times 59.3\%$)

How many watts is your turbine producing? Are you generating 4.65 watts? If you are, give us a call—we have a job for you! Most KidWind turbines get around 10–15%!

APPENDIX Q
DIRECT INSTRUCTION INSTRUCTIONAL MATERIALS

Wind Energy Direct Instruction Treatment

Lesson Plan #1

Key Components to the Direct Instruction Technique

- Ongoing Checking for Understanding of All Students
 - Immediate Corrective Feedback
 - Teacher Making Decisions based on Responses
 - High Expectations for Student Learning
 - Actively Engaged Students
 - Efficient Use of Instructional Time
 - Positive Classroom Environment
 - Routines and Procedures
 - Cues and Prompts
 - Choral Responses
 - Visual Representations and Graphic Organizers
-

IDENTIFICATION

INSTRUCTOR: Dr. J. Shane Robinson

UNIT TOPIC: Wind Energy – Basic Blade Design

LESSON TITLE: Wind Energy Basics and the Power Equation

CLASS: Treatment Group #1 DATE TAUGHT 9/18/2012

METHOD: Direct Instruction TIME: 45 minutes

TEACHING MATERIALS AND RESOURCES

- Model Wind Turbines
- Power Point Slides
- Worksheets 1.1 – 1.3

Orientation

CONTENT OBJECTIVES

Students will be able to...

1. Identify benefits and limitations of generating electricity from wind power
2. Correctly identify 4 primary components of a wind turbine (blades, hub, nacelle, tower)
3. Identify the 3 variables used to calculate available power in the wind (air density, turbine swept area, wind speed)
4. Identify which of these three variables has the greatest effect on turbine power output
5. Understand that there is a *theoretical maximum* percentage of the available power a turbine could extract from the wind called the Betz Limit.

ACTIVATE PRIOR KNOWLEDGE

Key Points

Link:

Place the model wind turbines on tables as students enter. Students will be placed in tables of five students.

Good Morning! Each of you has a model of an item you may or may not be familiar with. What do you know about these odd structures?

Ask students for feedback regarding their experience with wind turbines.

Some questions to spur conversation are:

Methods and Media

Have PowerPoint presentation slide #1 as students walk in.



1. *Where do you typically see these in Oklahoma?*
2. *Why are turbines built like the model at your table?*
3. *Is this a viable source of energy?*
4. *If it is so great why don't we produce all our energy through wind energy?*

Motivation:

Wind energy is a big deal in Oklahoma! It isn't the answer to all of our energy problems, but it can do a lot to produce clean energy.

It is important that we each understand the importance of wind energy, and a huge part of that is the engineering and design behind the huge wind turbines we see all across Oklahoma.

Overview:

By the end of the day, each of us will be building our own wind turbines! This will require each of us to know what makes wind turbines produce the most energy possible. Before we can build our own turbines, we must understand the principles of wind and blade design to be prepared to build our own. At the end of the day, one wind blade design champion will be named based on energy output of your wind turbine!

This morning, there will be three 45-minute workshops to cover the elements of blade design. This first workshop will cover:

1. The benefits of wind energy
2. The components of a wind turbine.
3. The Power Equation
4. How much wind can we capture?

Let's Begin!

Have small models placed in middle of tables prior to students entering the room.

What is our goal?

- This afternoon, each of you will be creating your own wind turbine based on what you learn today.
- The person that designs the wind turbine that produces the most power – will be taking home the golden wind turbine and a nice little prize – and bragging rights!
- Three morning sessions to prepare!

Objectives

- The benefits of wind energy
- The components of a wind turbine.
- The Power Equation
- How much wind can we capture?

Presentation and Guided Practice

Key Points

Objective 1: Benefits and Drawbacks of Wind Energy

Why wind energy? This is a question that many people are asking these days. To answer this question we need to first look at data in the form of graphs. Looking at graphs can really tell you a lot about the need for wind energy. When we look at any graph we should:

1. Look at the legend.
2. Identify the units to understand the scale.
3. Look at the axis or categories to determine the variables.
4. Look for trends.

We'll look at one graph together. *Show graph #1 of US Electricity Sources.* What does this graph tell us?

Have students share their interpretations with the group.

Using the principles discussed above, we can see that a great deal of the energy used today is produced by non-renewable means. A very small percentage utilizes renewable means.

Guided and Individual Practice – Graph Interpretation

Let's look at a few more graphs. Each of you will find a paper at your desk that has two other graphs. Read those graphs and work to determine what the graphs are telling you. What can we learn about wind energy using those graphs? Make sure to use the four strategies stated above!

Each instructor should partner with students to make sure you are giving feedback regarding their ability to correctly follow the steps. Provide coaching and praise leading to student competence.

From this data, I think we can begin to realize the importance of wind energy! Wind Energy is absolutely a renewable source of energy!

And it is one of the fastest growing energy sources. You can see OK was not investing in wind energy at all. Now look at the graph of capacity in 2009! OK is now in the top category of 1,000 – 9,500 MW of Wind Power Capacity.

This growth is because of many important benefits of wind energy. Listen carefully because you will have to recall these benefits and drawbacks. Some of the main benefits include:

1. Reduces negative environmental impacts to air, water, and wildlife.
2. Reduces carbon pumped into the atmosphere.
3. It is becoming cheaper.
4. Using renewable resource to produce energy.

Methods and Media

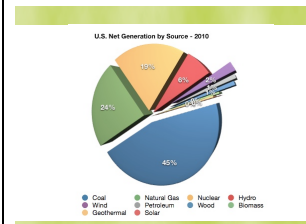

Worksheet 1.1: What are these graphs telling us?

Wind Energy

Benefits	Drawbacks
<ul style="list-style-type: none"> • Reduces negative environmental impacts to air, water, and wildlife. • Reduces carbon pumped into the atmosphere. • It is becoming cheaper. • Using renewable resource to produce energy. 	<ul style="list-style-type: none"> • Technology is being developed, but not perfect yet. • Wind is not reliable. • Moving energy produced on wind farms to urban areas where it is needed. • Landscape Impact • Sound – they are noisy! • Cheap fossil fuels are tough competition.

There are also a number of drawbacks and/or challenges:

1. Technology is being developed, but not perfect yet.
2. Wind is not reliable.
3. Moving energy produced on wind farms to urban areas where it is needed.
4. Landscape Impact
5. Sound – they are noisy!
6. Cheap fossil fuels are tough competition.

Advance the slide to the blank screen.

Guided and Individual Practice – Benefits and Drawback to Wind Energy

Using the sheet entitled “Benefits and Drawbacks” make an icon for each of the benefits and drawbacks we just mentioned. We’ll see how many you can remember! When you’re done we’ll check our answers.

Allow students to create the icons and then reveal the answers for them to check their own work.

Objective 2: Correctly identify 4 primary components of a wind turbine (blades, hub, nacelle, tower).

Now we know the reasoning behind wind energy, let’s learn the basics of a standard commercial wind turbine.

Let’s look at each of these items.

1. Blades attached to the hub (rotor spins in the wind)
2. Spins and drives the shaft (transfers force to gearbox)
3. Gearbox (increases shaft speed)
4. High speed shaft (transfers force to generator)
5. Generator (converts spinning shaft to electricity)
6. Wires to grid (provides electricity)

Guided and Individual Practice: Anatomy of a Wind Turbine

Now, we will try our best to explain these parts to our tables using the models that are provided. Every single person needs to explain the six components and what they do to a partner. The partner will check you for correctness using their notes.

Allow students to work through the model identifying the components. Teachers and TA’s should be present to check for understanding and coach where needed.

Now we know the basics of the wind turbines we see all over our state. It is time to begin to unlock the secrets behind these energy-producing monsters. How exactly do these monsters capture the wind and create energy to power our communities? It is all based on a nice little math equation called the power equation.

Objectives:

3. Identify the 3 variables used to calculate

Worksheet 1.2: Benefits and Drawbacks

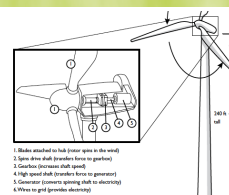

available power in the wind (air density, turbine swept area, wind speed).
4. Identify which of these three variables has the greatest effect on turbine power output.

The entire ability to create energy from wind is described in the following mathematical equation:

$$P = \frac{1}{2} \rho A V^3$$

What does this equation mean? In words this equation means:

Power = 1/2 x air density x swept area x wind velocity

This equation gives us a lot of hints about the best way to capture energy from the wind. What does this equation tell you about wind energy and designing wind turbines?

Have students share their ideas of this equation and their hypotheses in regards to blade and turbine design.

Great thoughts. Let's look at each of these elements by themselves. First, let's look at air density. More dense, or "heavier" air will push blades with more force and thus create more power. Turbines in mountain rages, where the air density is low, can produce almost 40% less power because of this reduction in air density. The same thing happens with wind turbines. The denser the air is, the more force it places on the blade as it moves. In Stillwater the density of air is approximately:

$$\rho = 1.224 \text{ kg/m}^3$$

What about the A or Swept Area? As you can see on the power point, the swept area is the area of the circle that is covered by the blades when spinning. This is calculated the same way the area of a circle is calculated. Area = πr^2 . You remember that pi is 3.14 and r is the radius of a circle. In this case, the radius of the circle is the length of the blade. So for example a blade that is 10 meters long will have a swept area of what?

Let students respond.

That's right – 314 meters squared.

$$P = \frac{1}{2} \rho A V^3$$

Calculation of Wind Power

Power in the Wind = $\frac{1}{2} \rho A V^3$

- Effect of swept area, A
- Effect of wind speed, V
- Effect of air density, ρ

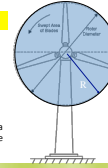

Swept Area: $A = \pi R^2$ Area of the circle swept by the rotor (m^2).

ρ

- Air Density
- The more dense, the more the air moves the turbines.
- Average density is around 1.224 kg/m³

Swept Area

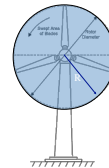

- $A = \pi r^2$
- R is the radius of the blade
- $\pi = 3.14$
- Bigger area means larger column of air to collect
- Blades move slower

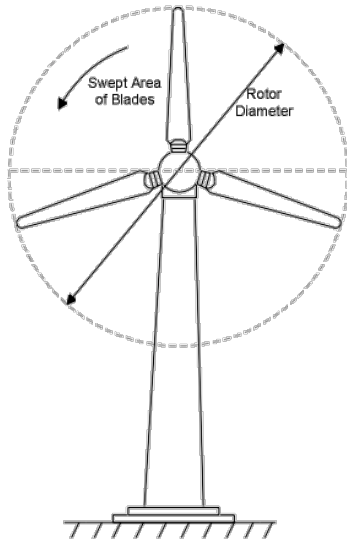

So, the bigger the swept area, the more opportunity for wind to be captured.

The final element of the equation is the velocity of the wind. This is a pretty straightforward and simple idea. The faster the wind blows, the more power can be created. It is interesting to note that the velocity of the wind is cubed. What does this tell you?

Students respond.

That is right; the velocity of the wind **is the most influential element in the wind power equation**. The more wind velocity, the more power created.

What is the most influential component of the wind equation?

Have students respond V...V...V...Velocity

Guided and Individual Practice: Calculating Power from the Power Equation

Now we are going to calculate the power, in Mega Watts (MW), of a certain wind turbine together. Let's say that you have the following data:

- Blade Length: 52 meters
- Wind Speed: 12 meters/second
- Air Density: 1.23 kg/m³

Using the Power Equation, how much power would this turbine be creating?

$$P = \frac{1}{2} \rho A V^3$$

The only item we have to calculate is what?

V³

- Velocity of the Wind
- Cubed
- V * V * V
- Three times the impact of other variables
- The most influential component of the equation.
- V...V...V...Velocity

©2010 Project | www.ck12.org

Let's Practice

- Blade Length: 52 meters
- Wind Speed: 12 meters/second
- Air Density: 1.23 kg/m³

What is the Power Output?

Swept Area.

It is calculated as follows: $A = 3.14 (52)^2$

So Area would equal: $8,490.56 \text{ m}^2$

Now with the whole equation:

Power = $\frac{1}{2} * 1.23 * 8490.56 * 12^3 = 9,022,492$ Watts of Energy

Let's try some of these on our own.

*Show the two scenarios, one at a time, to the students. Have students calculate the power that a wind turbine could be expected to produce on the Power Equation Worksheet **first as a group, and then have each student calculate it by themselves.** Walk around to each student and provide feedback on his or her logic and final answer.*

Objective 5: Understand that there is a theoretical maximum percentage of the available power a turbine could extract from the wind called the Betz Limit.

Obviously we want to collect as much wind as possible and turn that into power as the power equation explains. However, we can never collect all of the wind. In order to keep the wind moving through the

Answer?

- It is calculated as follows: $A = 3.14 (52)^2$
- So Area would equal: $8,490.56 \text{ m}^2$
- Now with the whole equation:
– Power = $\frac{1}{2} * 1.23 * 8490.56 * 12^3 = 9,022,492$ Watts of Energy

K12Wind Project | www.k12wind.org

Worksheet 1.3: Power Equation Practice

**Group Work Scenario
Small Home Turbine**

- Blade Length: 20 meters
- Wind Speed: 12 meters/second
- Air Density: 1.23 kg/m^3

What is the Power Output?

K12Wind Project | www.k12wind.org

Answer?

- It is calculated as follows: $A = 3.14 (20)^2$
- So Area would equal: $8,490.56 \text{ m}^2$
- Now with the whole equation:
– Power = $\frac{1}{2} * 1.23 * 1256 * 12^3 = 1,334,776$ Watts of Energy

K12Wind Project | www.k12wind.org

**Individual Work Scenario
Large Turbine on Windy Mountain Peak**

- Blade Length: 60 meters
- Wind Speed: 35 meters/second
- Air Density: 1.00 kg/m^3

What is the Power Output?

K12Wind Project | www.k12wind.org

Answer?

- It is calculated as follows: $A = 3.14 (60)^2$
- So Area would equal: $8,490.56 \text{ m}^2$
- Now with the whole equation:
– Power = $\frac{1}{2} * 1.00 * 11,304 * 35^3 = 242,329,500$ Watts of Energy

K12Wind Project | www.k12wind.org

wind turbines, a certain amount of the wind must be left alone. There is a limit to how much wind can be collected. That limit is called the:

Betz Limit

The theoretical limit, or betz limit, of rotor efficiency is 59%. So theoretically, we could collect 59% of the wind and convert it to power. Usually about 70% of that 59% is actually converted to power.

Most modern wind turbines collect in the 35 – 45% range.

Guided and Individual Practice:

Let's go back to the first turbine example we calculated above. 9,022,492 Watts of Energy was produced.

Have students get out their power equation practice sheets to continue their calculations for Betz on the same page.

How much of that total possible power be THEORETICALLY captured using the Betz Limit?

$$9,022,492 \text{ Watts of Energy} * 59\% (.59) = 5,323,270.75 \text{ Watts}$$

And 70% of that amount is what most wind turbines ACTUALLY collect. That would be:

$$5,323,270.75 \text{ Watts} * .70 = 3,726,289.53 \text{ Watts}$$

Using this same strategy, calculate the theoretical and actual power outputs for the other two wind turbines. Do the second as a group and the third by yourself!

Check both the process and the final answers to ensure they are calculating the limits correctly. Provide feedback to those that are doing this correctly.

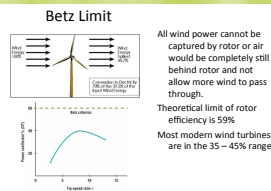

Worksheet 1.3: Power Equation Practice

Lesson Closure:

This morning we have learned:

- The benefits and drawbacks of wind energy.
- The parts of a wind turbine.
- The Power Equation
- The Betz limit

We now understand the basics of how turbines work. Now we will begin to dive deeper into the design of the blades so that you can better prepare to design your own blades this afternoon!

Next we will look at the importance of solidity and what different blade variables will do to the amount of power produced by a wind turbine.

* This curriculum is an adapted version of KidWind Project®, and WindWise Education materials.

What Are These Graphs Telling Us?

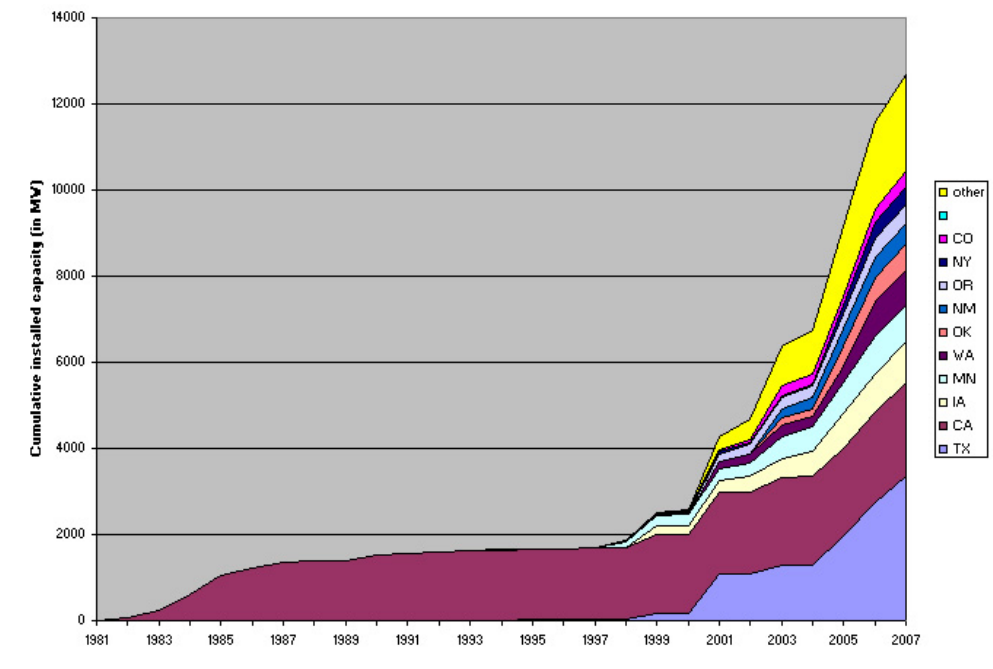

What is depicted on the two axes of this graph?

What conclusion do you draw from this graph about wind energy?

What Are These Graphs Telling Us?

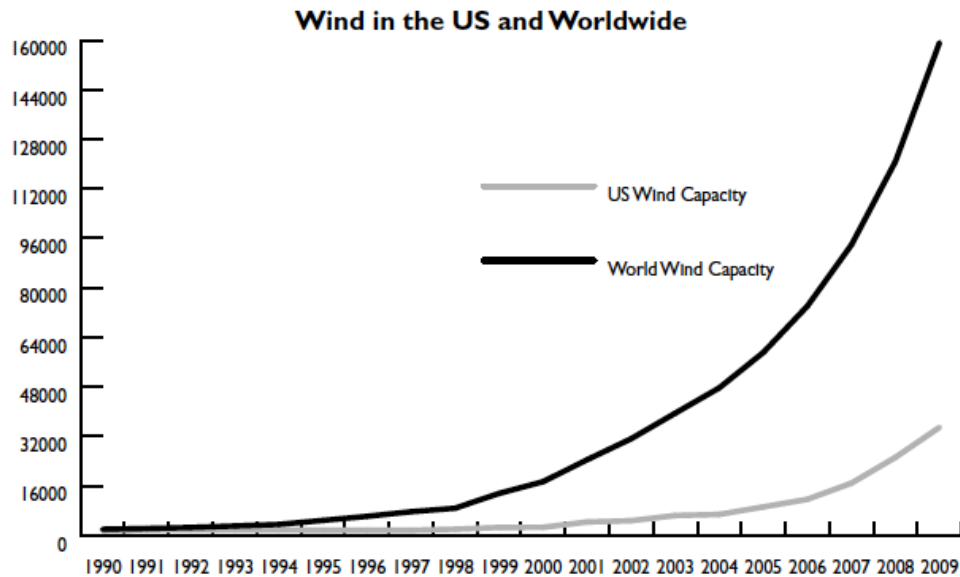

What is depicted on the two axes of this graph?

What conclusion do you draw from this graph about wind energy?

Wind Energy

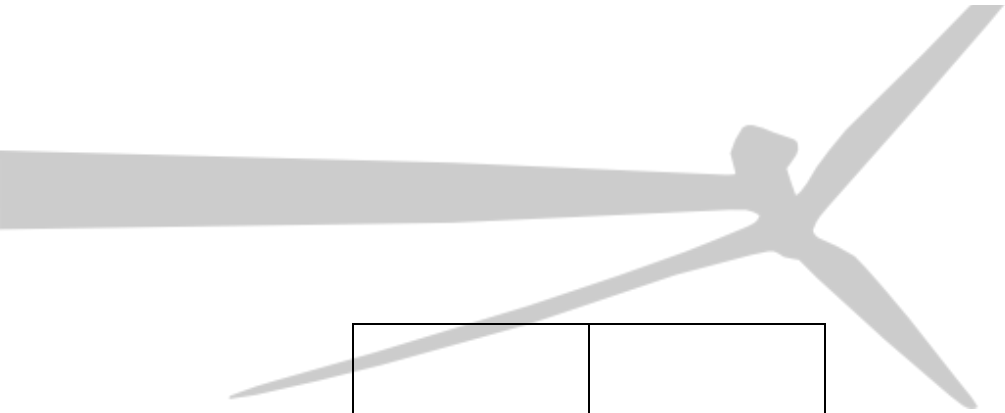

Benefits

Drawbacks

Power Equation Practice Sheet

$$P = \frac{1}{2} \rho A V^3$$

Scenario #1: Regular Commercial Turbine

Scenario #2: Small Home Turbine

Scenario #3: Large Mountain Turbine



What is our goal?

- This afternoon, each of you will be creating your own wind turbine based on what you learn today.
- The person that designs the wind turbine that produces the most power – will be taking home the golden wind turbine and a nice little prize – and bragging rights!
- Three morning sessions to prepare!

KidWind Project | www.kidwind.org

Objectives

- The benefits of wind energy
- The components of a wind turbine.
- The Power Equation
- How much wind can we capture?

KidWind Project | www.kidwind.org

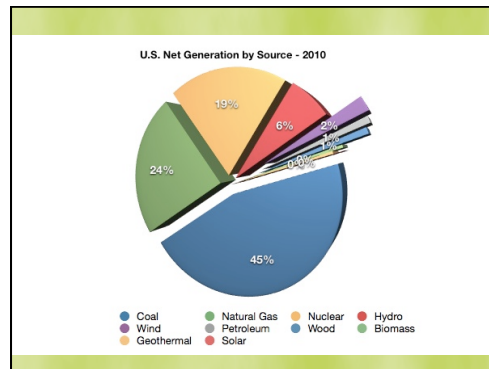

Wind Energy

<h4 style="text-align: center;">Benefits</h4> <ul style="list-style-type: none"> • Reduces negative environmental impacts to air, water, and wildlife. • Reduces carbon pumped into the atmosphere. • It is becoming cheaper. • Using renewable resource to produce energy. 	<h4 style="text-align: center;">Drawbacks</h4> <ul style="list-style-type: none"> • Technology is being developed, but not perfect yet. • Wind is not reliable. • Moving energy produced on wind farms to urban areas where it is needed. • Landscape Impact • Sound – they are noisy! • Cheap fossil fuels are tough competition.
---	--

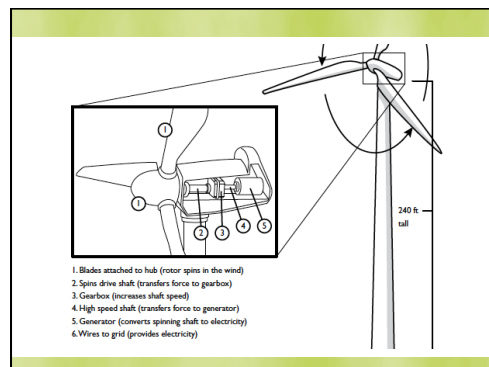

$$P = \frac{1}{2} \rho A V^3$$

Calculation of Wind Power

Power in the Wind = $\frac{1}{2}\rho AV^3$

- Effect of swept area, A
- Effect of wind speed, V
- Effect of air density, ρ

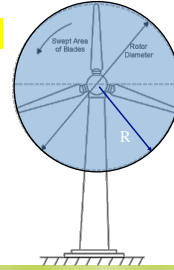

Swept Area: $A = \pi R^2$ Area of the circle swept by the rotor (m^2).

ρ

- Air Density
- The more dense, the more the air moves the turbines.
- Average density is around 1.224 kg/ m^3

Swept Area

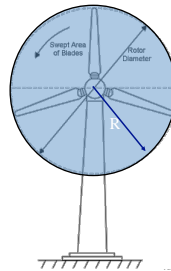

- $A = \pi R^2$
- R is the radius of the blade
- $\pi = 3.14$
- Bigger area means larger column of air to collect
- Blades move slower

V^3

- Velocity of the Wind
- Cubed
- $V * V * V$
- Three times the impact of other variables
- The most influential component of the equation.
- V...V...V...Velocity

KidWind Project | www.kidwind.org

Let's Practice

- Blade Length: 52 meters
- Wind Speed: 12 meters/second
- Air Density: 1.23 kg/ m^3

What is the Power Output?

Answer?

- It is calculated as follows: $A = 3.14 (52)^2$
- So Area would equal: 8,490.56 m²
- Now with the whole equation:
 - Power = $\frac{1}{2} * 1.23 * 8490.56 * 12^3 = 9,022,492$ Watts of Energy

KidWind Project | www.kidwind.org

Group Work Scenario Small Home Turbine

- Blade Length: 20 meters
- Wind Speed: 12 meters/second
- Air Density: 1.23 kg/m³

What is the Power Output?

KidWind Project | www.kidwind.org

Answer?

- It is calculated as follows: $A = 3.14 (20)^2$
- So Area would equal: 8,490.56 m²
- Now with the whole equation:
 - Power = $\frac{1}{2} * 1.23 * 1256 * 12^3 = 1,334,776$ Watts of Energy

KidWind Project | www.kidwind.org

Individual Work Scenario Large Turbine on Windy Mountain Peak

- Blade Length: 60 meters
- Wind Speed: 35 meters/second
- Air Density: 1.00 kg/m³

What is the Power Output?

KidWind Project | www.kidwind.org

Answer?

- It is calculated as follows: $A = 3.14 (60)^2$
- So Area would equal: 8,490.56 m²
- Now with the whole equation:
 - Power = $\frac{1}{2} * 1.00 * 11,304 * 35^3 = 242,329,500$ Watts of Energy

KidWind Project | www.kidwind.org

Betz Limit

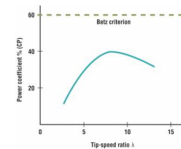
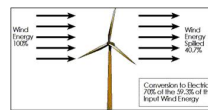

All wind power cannot be captured by rotor or air would be completely still behind rotor and not allow more wind to pass through.

Theoretical limit of rotor efficiency is 59%

Most modern wind turbines are in the 35 – 45% range

Wind Energy Direct Instruction Treatment

Lesson Plan #2

Key Components to the Direct Instruction Technique

- | | |
|---|---|
| <ul style="list-style-type: none"> • Ongoing Checking for Understanding of All Students • Immediate Corrective Feedback • Teacher Making Decisions based on Responses • High Expectations for Student Learning • Actively Engaged Students | <ul style="list-style-type: none"> • Efficient Use of Instructional Time • Positive Classroom Environment • Routines and Procedures • Cues and Prompts • Choral Responses • Visual Representations and Graphic Organizers |
|---|---|

IDENTIFICATION

INSTRUCTOR: Dr. J. Shane Robinson _____
 UNIT TOPIC: Wind Energy – Basic Blade Design _____
 LESSON TITLE: Wind Energy Basics and the Power Equation _____
 CLASS: Treatment Group #2 _____ DATE TAUGHT 9/18/2012 _____
 METHOD: Direct Instruction TIME: 45 minutes

TEACHING MATERIALS AND RESOURCES

- Worksheet 2.1: Calculating Solidity
- Power Point Slides – DI Lesson 2

Orientation

CONTENT OBJECTIVES

Students will be able to...

1. Understand the concept of solidity and how it is calculated
2. Given two different rotor configurations (one high solidity, one low), identify which rotor would generate more torque and which would spin at higher RPM.
3. Be able to calculate rotor solidity with given input variables (swept area and rotor area)
4. Understand how drag affects a wind turbine blade as it rotates through the air
5. Understand that the principle of lift makes turbine blades more efficient
6. Understand how a wind turbine blade uses an airfoil profile shape to generate lift

ACTIVATE PRIOR KNOWLEDGE

Key Points

Link:

Welcome Back! Quick break I know, but now we are going to really get into what will make your turbines rise above the rest this afternoon!

Let's quickly review the last 45 minutes we spent together. What were the major concepts we covered?

Have students share elements that they remember. Seek understanding in the major concepts of the power equation, benefits and drawbacks of wind energy, and the Betz Limit.

How closely related do you think an airplane is to a wind turbine?

Methods and Media



Elicit responses from the students.

Some blades are actually built to simulate the same effect of an airplane wing – to lift!

What are the major differences between a wind turbine for energy and a windmill to pump water?

Elicit student responses.

A windmill has more blades, which creates what we call solidity. Basically, how solid is the area of the blades. The more solid the more torque, but the slower, a windmill turns.

These concepts are key to producing energy from wind.

Motivation:

If you understand solidity, you will have a better idea of how to build your wind turbine to either create torque or speed. Lift and drag helps you understand how to make your wind turbine more efficient – which could mean sweet victory in the afternoon competition! Airfoil is a unique design that creates lift.

Overview:

Now we are going to build on those major concepts. We understand where power comes from through the power equation, but how do these huge blades collect that wind? The next step is to understand:

1. What solidity is and how it affects a wind turbine
2. The difference between lift and drag
3. Airfoil designs that you see on most wind turbines

Let's Begin!

Objectives

- What solidity is and how it affects a wind turbine
- The difference between lift and drag
- Airfoil designs that you see on most wind turbines

K12Wind Project | www.k12wind.org

Presentation and Guided Practice

Direct Instruction #2 Page 2

Objectives:

- 1. Understand the concept of solidity and how it is calculated**
- 2. Given two different rotor configurations (one high solidity, one low), identify which rotor would generate more torque and which would spin at higher RPM.**

What does solidity sound like to you?

Solidity is a way to explain, with a percentage how solid something is. A wall has 100% solidity, but a three-blade wind turbine may have 10% solidity. It goes back to the idea of the swept area.

Who can remind us of what the swept area is?

Check for understanding.

Exactly – it is the surface area of the circle created by the moving blades. The question solidity seeks to answer is, “How solid is that swept area?”

Let’s look at two examples: A windmill and a three-blade wind turbine. *Use the power point slide to demonstrate.*

The three-blade wind turbine has a very low solidity – 10%. This leads to a high blade speed, but low torque. Torque refers to how much twisting force is provided from the wind.

A windmill, on the other hand, has a very high solidity – 80%. This leads to slower moving blades, but a higher torque.

Why would we choose high or low solidity? Think about the goal of a windmill vs. the goal of a wind turbine?

Students should respond to the fact that a windmill needs to do more work while a turbine needs to simply spin fast to increase RPM to run the generator and make energy. Reward those responses in line with this response.

Guided and Individual Practice – Solidity

We are going to play a game of “Name that Solidity.” I will show two different wind turbines, and you must make a distinction between the two based on solidity. Use your Solidity Expert Sheet to record your answers.

Show each of the options using the power point and have students make their selection. Once everyone has made a choice, share the correct answer and also take the chance to ask about other elements not discussed in the direct question – for example ask about torque if the question is on speed only.

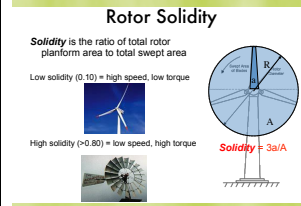

Answers:

Comparison One: The design on the left has more solidity.

Comparison Two: The one on the left produces more torque

Comparison Three: The three blade creates more blade speed

Comparison Four: The one on the right has more solidity.

Objective 3: Be able to calculate rotor solidity with given input variables (swept area and rotor area)

We have discussed solidity and what it does for wind turbines. It's possible to actually calculate the exact solidity of a turbine. You are literally calculating a percentage of the swept area that is covered by blades.

To do this we use the equation:

$$\text{Solidity} = 3a / A$$

This equation tells us that to calculate the solidity, you find the area of one blade, multiply that number by the number of blades (3 in this example) and divide that by the total swept area. That gives you the ratio of blade area to total swept area. That can easily be converted to a percentage by multiplying it by 100. For example if the solidity is .13, that is multiplied by 100 to give us a 13% solidity.

Guided and Individual Practice: Anatomy of a Wind Turbine

Which has the highest solidity?

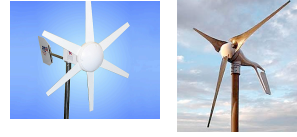

Which produces the most torque?



Which should create the most blade speed?



Which has the highest solidity?



Calculating Solidity

- Solidity = $3a/A$
- Take the area of a blade.
- Multiply it by three.
- Divide it by swept area to get percentage.

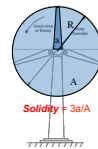

We'll make sure we have this equation down. Let's start by doing one together as a class. Here is the scenario:

*Use the power point slides to present the scenario. The students will use **Worksheet 2.1** to work out the problem. Let the students work the scenario and then discuss the solution once people have come to a solution.*

Scenario #1: Do this one as a class

Scenario #2: Have students work together to solve this problem.

Scenario #3: Have students do this individually.

Worksheet 2.1: Calculating Solidity

Scenario #1: As a Class

- There is a wind turbine used in a small community. The swept area is 2000 m² because the blades were around 25 meters long. The five blades were 120 m² each.
- What is the solidity?
- What does this mean for speed and torque?

Scenario #1: Solution

- $5(120) / 2000 = 0.3$ or 30%
- What is the solidity?
 - .3 or 30%
- What does this mean for speed and torque?
 - Pretty average speed and torque.

Scenario #2: As a Group

- There is a wind turbine being placed in a typical wind farm. The swept area is 9000 m². The three blades were 300 m² each.
- What is the solidity?
- What does this mean for speed and torque?

Scenario #2: Solution

- $3(300) / 9000 = 0.1$ or 10%
- What is the solidity?
 - .1 or 10%
- What does this mean for speed and torque?
 - Blades will be moving fast which leads to high RPM and energy produced.

Scenario #3: By Yourself

- A farmer uses a newly designed windmill to pump water. The swept area is 314 m² because the blades were around 10 meters long. The three blades were 13 m² each, and very lightweight.
- What is the solidity?
- Will this make a good water pumping windmill? Why?

Scenario #3: Solution

- $3(13) / 314 = 0.124$ or 12.4%
- What is the solidity?
 - .124 or 12.4%
- Good windmill?
 - The blades would move fast, but might struggle to have enough torque to pump the water.
 - How would you increase torque?

Objectives:

4. Understand how drag affects a wind turbine blade as it rotates through the air.
5. Understand that the principle of lift makes turbine blades more efficient.
6. Understand how a wind turbine blade uses an airfoil profile shape to generate lift.

Now that we understand solidity, we can begin to see that the way the blades are designed make a big difference in how fast or how much torque is created by the wind.

It is very important that we create efficient blades. Sloppy, poorly made blades will never make enough electricity to do anything. However, nothing is more important than the creating efficient blades.

Lift and Drag are key concepts to understand. These forces are in constant competition. When you are optimizing wind turbine blades, try to maximize lift force but minimize drag force.

Drag:

In a wind turbine, also called wind resistance. Friction of the blades against air molecules as they rotate. Drag works against the rotation of the blade causing them to slow down.

One thing you must always think about when making turbine blades is “How much drag are my blades encountering?” Sure, your blades are probably catching the wind and helping to spin the hub and motor driveshaft, but could they be spinning faster?

If the blade is adding drag, your whole system will slow down. Low speed means low RPM's, which means less power output.

Lift:

A force experienced by the blades that is perpendicular to the oncoming flow of air. Lift is a force working to speed up the rotation of the blades.

Lift is primarily produced as a result of the angle-of-attack of the blade. This angle creates a deflection force on the upwind side and a vacuum force on the downwind side of a wind turbine blade. When blades become more like an airplane wing, lift is created and that drives the blades to move.

Airfoil designs are designed to create lift and minimize turbulence. Most turbines you see in Oklahoma today use this design. As you can see in the power point, the faster air flowing over the rounded part of the wing creates low pressure and thus LIFTS!

Lift:
A force experienced by the blades that is perpendicular to the oncoming flow of air. Lift is a force working to speed up the rotation of the blades.

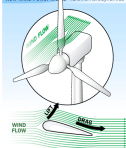

Drag:
In a wind turbine, also called wind resistance. Friction of the blades against air molecules as they rotate. Drag works against the rotation of the blade causing them to slow down.

Lift & Drag Forces

- The **Lift Force** is perpendicular to the direction of motion. We want to make this force **BIG**.
 $\alpha = \text{low}$
 $\alpha = \text{medium}$ < 10 degrees
- The **Drag Force** is parallel to the direction of motion. We want to make this force **small**.
 $\alpha = \text{High}$ **Stall!**

Airfoil Shape

Just like the wings of an airplane, wind turbine blades use the airfoil shape to create lift and maximize efficiency.

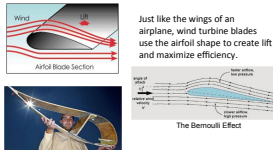

The Bernoulli Effect

Guided and Individual Practice: Anatomy of a Wind Turbine

Let's give ourselves a quick check. Do we know lift and drag? I will show two blades and you have to select the one with either the most drag or lift. Make the decision first by yourself, then consult with some friends, and then we will discuss it as a group.

I will:

- Show the picture.
- Say, By Yourself
- Say, With your group
- Say, With the class.

Show each of the slides and follow the protocol given above. Provide feedback and praise for correct answers.

Roughly made blades create more drag than smooth ones. Both are airfoil designs.

Smaller blade tips create less drag because the tip moves through the air so much faster than the base. The one on the right has less drag. Lift not a huge issue here.

More blades = more drag. Lift not really an issue here.

Bigger is not better. Bigger blades typically create more drag.

Blades that are outside of the column of air create more drag because there is no wind but drag remains.

Which has the most drag/most lift?



Kahoot! Project | www.kahoot.org

Which has the most drag/most lift?

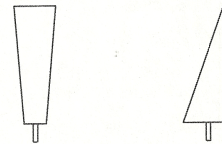

Kahoot! Project | www.kahoot.org

Which has the most drag/most lift?

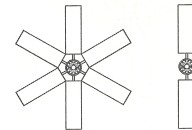

Kahoot! Project | www.kahoot.org

Which has the most drag/most lift?

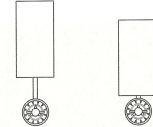

Kahoot! Project | www.kahoot.org

Which has the most drag/most lift?

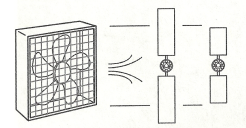

The 90 degree creates little lift or drag. The 45 degree creates lift and drag. The 0 degree creates lots of drag and little lift.

The airfoil design creates more lift and the flat blade creates more drag.

Which has the most drag/most lift?

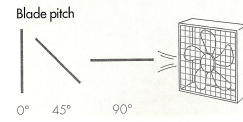

Which has the most drag/most lift?

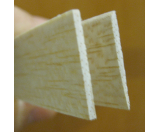

Lesson Closure:

This session we have learned:

- What solidity means for turbines
- How to calculate solidity.
- The role of lift and drag
- Airfoil designs

This afternoon you are going to create a wind turbine on your own. You should be beginning to make some decisions regarding what would create a wind turbine that creates the most energy!

Let's take a quick break, and then get ready for one last session where we will learn many of the blade factors we can change to make our turbines work most effectively!

*** This curriculum is an adapted version of KidWind Project ®, and WindWise Education materials.**

Calculating Solidity

Scenario Number 1: Do this one together as a class.

There is a wind turbine used in a small community. The swept area is 2000 m^2 because the blades were around 25 meters long. The five blades were 120 m^2 each.

What is the solidity?

What would this solidity do for torque and speed?

Scenario Number 2: Do this one together with other students.

There is a wind turbine being placed in a typical wind farm. The swept area is 9000 m^2 . The three blades were 300 m^2 each.

What is the solidity?

What would this solidity do for torque and speed?

Scenario Number 3: Do this by yourself.

A farmer uses a newly designed windmill to pump water. The swept area is 314 m^2 because the blades were around 10 meters long. The three blades were 13 m^2 each, and very lightweight.

What is the solidity?

Do you expect this design to be effective in creating torque to pump water? Why?

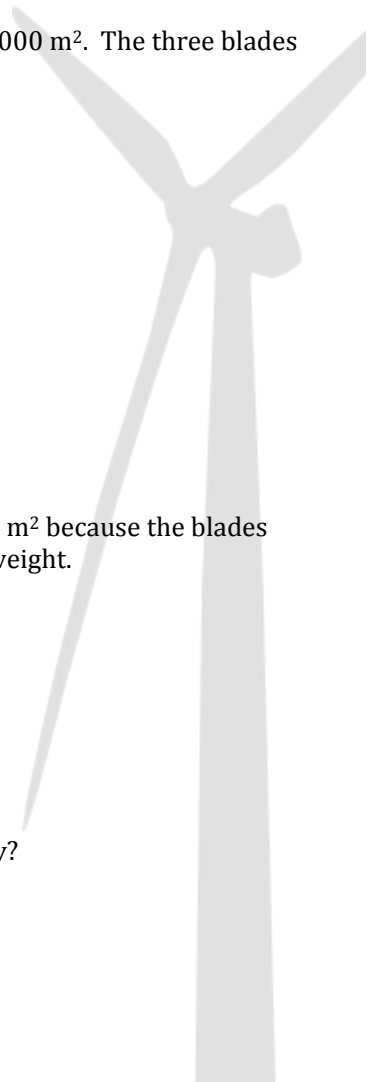



Objectives

- What solidity is and how it affects a wind turbine
- The difference between lift and drag
- Airfoil designs that you see on most wind turbines

KidWind Project | www.kidwind.org

Rotor Solidity

Solidity is the ratio of total rotor planform area to total swept area

Low solidity (0.10) = high speed, low torque





High solidity (>0.80) = low speed, high torque

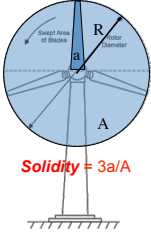



Solidity = $3a/A$



Which has the highest solidity?

Which produces the most torque?



Which should create the most blade speed?





Which has the highest solidity?

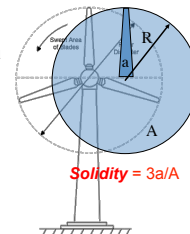

Calculating Solidity

- Solidity = $3a/A$
- Take the area of a blade.
- Multiply it by three.
- Divide it by swept area to get percentage.



Scenario #1: As a Class

- There is a wind turbine used in a small community. The swept area is 2000 m^2 because the blades were around 25 meters long. The five blades were 120 m^2 each.
- What is the solidity?
- What does this mean for speed and torque?

Scenario #1: Solution

- $5(120) / 2000 = 0.3$ or 30%
- What is the solidity?
 - .3 or 30%
- What does this mean for speed and torque?
 - Pretty average speed and torque.

Scenario #2: As a Group

- There is a wind turbine being placed in a typical wind farm. The swept area is 9000 m^2 . The three blades were 300 m^2 each.
- What is the solidity?
- What does this mean for speed and torque?

Scenario #2: Solution

- $3(300) / 9000 = 0.1$ or 10%
- What is the solidity?
 - .1 or 10%
- What does this mean for speed and torque?
 - Blades will be moving fast which leads to high RPM and energy produced.

Scenario #3: By Yourself

- A farmer uses a newly designed windmill to pump water. The swept area is 314 m² because the blades were around 10 meters long. The three blades were 13 m² each, and very lightweight.
- What is the solidity?
- Will this make a good water pumping windmill? Why?

Scenario #3: Solution

- $3(13) / 314 = 0.124$ or 12.4%
- What is the solidity?
 - .124 or 12.4%
- Good windmill?
 - The blades would move fast, but might struggle to have enough torque to pump the water.
 - How would you increase torque?

Lift:

A force experienced by the blades that is perpendicular to the oncoming flow of air. Lift is a force working to speed up the rotation of the blades.

Drag:

In a wind turbine, also called wind resistance. Friction of the blades against air molecules as they rotate. Drag works against the rotation of the blade causing them to slow down.

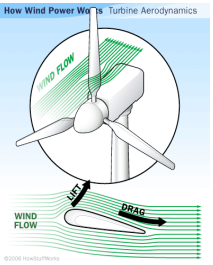

How Wind Power Works: Turbine Aerodynamics

Lift & Drag Forces

- The **Lift Force** is perpendicular to the direction of motion. We want to make this force BIG.
- The **Drag Force** is parallel to the direction of motion. We want to make this force small.

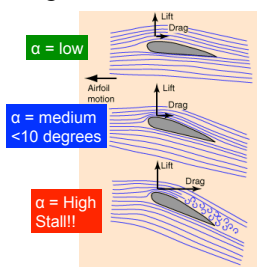

Airfoil Shape

Just like the wings of an airplane, wind turbine blades use the airfoil shape to create lift and maximize efficiency.

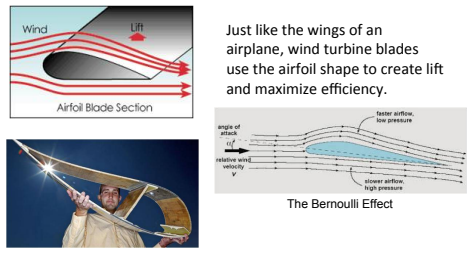

The Bernoulli Effect

Which has the most drag/most lift?



KidWind Project | www.kidwind.org

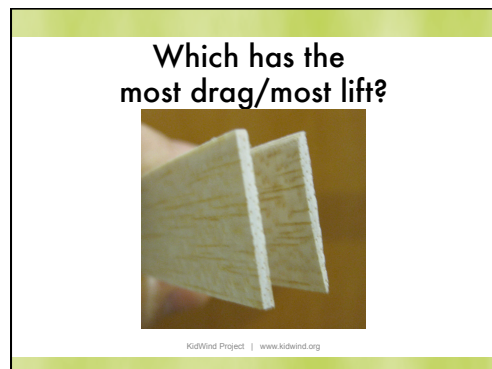
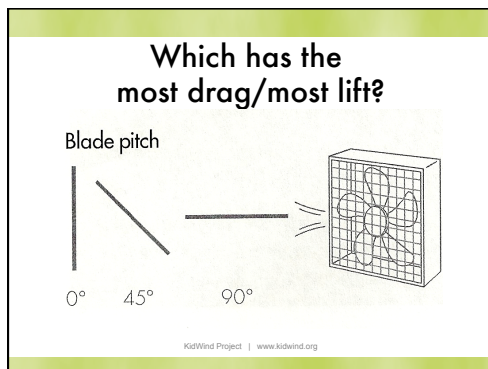
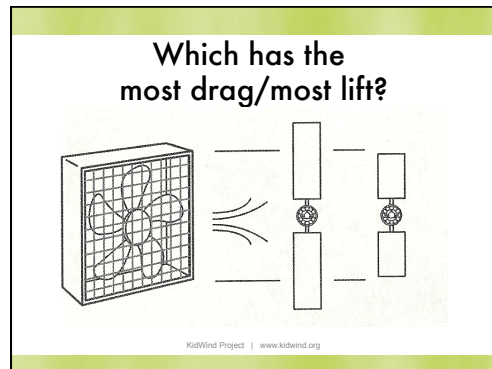
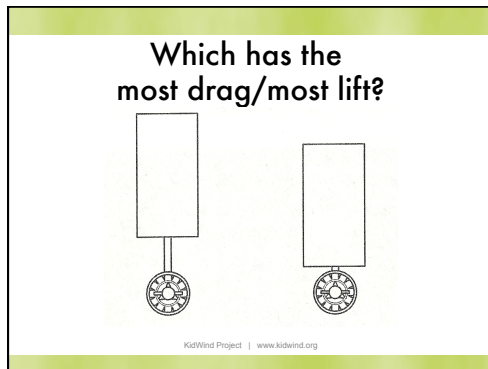
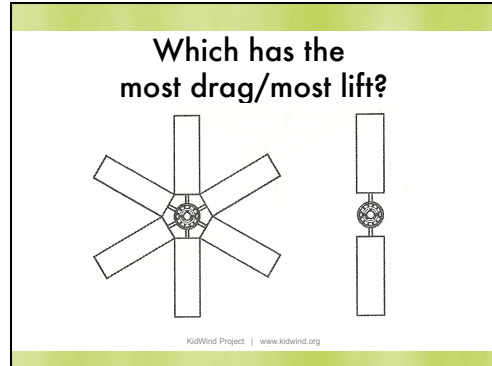
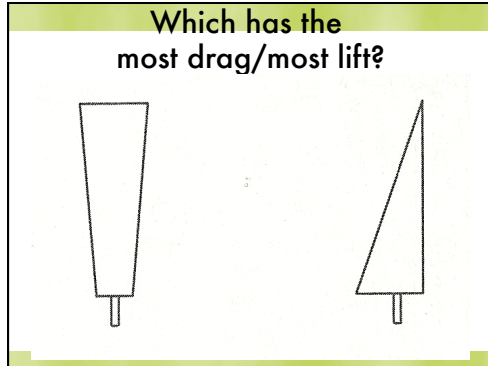

VITA

Marshall A. Baker

Candidate for the Degree of

Doctor of Philosophy

Thesis: THE EFFECT OF KOLB'S EXPERIENTIAL LEARNING MODEL ON SUCCESSFUL SECONDARY STUDENT INTELLIGENCE AND STUDENT MOTIVATION

Major Field: Agricultural Education

Biographical:

Education:

Completed the requirements for the Doctor of Philosophy in Agricultural Education at Oklahoma State University, Stillwater, Oklahoma in December, 2012.

Completed the requirements for the Master of Science in Agricultural Education at University of Florida, Gainesville, Florida in 2006.

Completed the requirements for the Bachelor of Science in Agricultural Education at University of Florida, Gainesville, Florida in 2004.

Experience:

Principal and Director of Alternative Education, Lincoln Academy (August, 2012 – Present).

Graduate Research and Teaching Assistant, Oklahoma State University (August, 2010 – August, 2012).

Biology and Agriscience Educator, Cleveland High School (May, 2009 – June, 2010).

Advisor and Head of Science, Indianapolis Metropolitan High School (May, 2007 – June, 2009).

Educational Specialist, National FFA Organization (January, 2006 – May 2007)

Professional Memberships:

American Association of Agricultural Educators

Name: Marshall A. Baker

Date of Degree: December, 2012

Institution: Oklahoma State University

Location: Stillwater, Oklahoma

Title of Study: THE EFFECT OF KOLB'S EXPERIENTIAL LEARNING MODEL ON
SUCCESSFUL SECONDARY STUDENT INTELLIGENCE AND
STUDENT MOTIVATION

Pages in Study: 285

Candidate for the Degree of Doctor of Philosophy

Major Field: Agricultural Education

Abstract: Experiential learning, as defined by Kolb (1984), is an important pedagogical approach used in secondary agricultural education. Though anecdotal evidence supports the use of experiential learning, a paucity of empirical research exists supporting this approach. The purpose of the study was to examine the effects of an experiential learning approach to instruction on secondary agricultural education students' successful intelligence and motivation for the course and knowledge retention. The experimental examination compared the commonly used DI approach to experiential learning, and investigated the interaction between students' learning style and instructional approach. The study was framed by three research questions: (1) What interactions exist between students' preferred learning styles, successful intelligence, and the instructional approach chosen? (2) What statistically significant differences exist in students' successful intelligence and motivation for the course between experiential learning and direct instruction approaches? (3) Do the analytical effects achieved by experiential and direct instructional approaches persist over time? Data were analyzed using a CRF – 22 and SPF 2·3 design. It was concluded that experiential learning led to higher domain specific creativity and practical use of knowledge, while direct instruction yielded higher practical knowledge scores. There were no statistically significant differences in motivation based on instructional approach. Also, it was concluded that, though students in both groups demonstrated a statistically significant increase in analytical scores, those gains significantly decreased for both treatment groups six weeks after the instruction. Thus, it was recommended that agricultural educators utilize a blended approach of instruction to provide balanced growth in all four modes of learning. Also, methods of assessment should be expanded to include not only analytical examinations, but also practical and domain specific creative measures. Experiential learning is an effective pedagogical approach when designed purposefully to meet each of the four learning modes inherent in Kolb's (1984) ELT model.

ADVISER'S APPROVAL: Dr. J. Shane Robinson
