

UNIVERSITY OF OKLAHOMA
GRADUATE COLLEGE

GAIT ANALYSIS OF PEOPLE WITH TRANSTIBIAL AMPUTATION

A THESIS
SUBMITTED TO THE GRADUATE FACULTY
in partial fulfillment of the requirements for the
Degree of
MASTER OF SCIENCE

By
BHANU PRASAD KOTAMRAJU
Norman, Oklahoma
2017

GAIT ANALYSIS OF PEOPLE WITH TRANSTIBIAL AMPUTATION

A THESIS APPROVED FOR THE
SCHOOL OF ELECTRICAL AND COMPUTER ENGINEERING

BY

Dr. Sesh Commuri, Chair

Dr. Choon Yik Tang

Dr. John Dyer

© Copyright by BHANU PRASAD KOTAMRAJU 2017
All Rights Reserved.

In memory of my late grandfather C.R.RAO

Acknowledgements

Firstly, I would like to thank my advisor Dr. Sesh Commuri who has been instrumental in guiding me throughout my graduate studies. He has always supported me both academically and morally. I can say it from the bottom of my heart that this thesis would not have been possible without his guidance.

I would like to thank my family overseas for their unconditional love and support for the past three years. It is their love and support that instills confidence in me to pursue my goals.

I would also like to take this opportunity to thank Dr. Anh Mai for his guidance through the whole process. I would also like to thank Mrs. Fauzia Ahmed, Dr. Imran Asif, and Mr. Ravi Soni. They weighed in time and again helping me with my graduate studies making my life much easier as a graduate student and gave me some memories that I am really fond of.

The doctors, and graduate students at the University of Oklahoma Health Sciences have been really helpful throughout the whole study. Dr. Carol Dionne, Mr. Jonathan Day, Mrs. Veris Kimberly, Dr. Derek Crawford, Ms. Crystal Rose deserve a special mention. Without their insight into the clinical aspects of this study, this thesis would not have been complete.

This acknowledgment section would be incomplete without mentioning the OU badminton club. This club has been like a second family to me and they helped me get through some of the toughest times I faced at OU. Some of the most memorable times I have at OU are from this club and I will be ever thankful to this club and its members.

Last but not the least, I would like to thank Dr. Choon Yik Tang and Dr. John Dyer for serving on my master's thesis committee.

Table of Contents

Acknowledgements	iv
List of Tables	ix
List of Figures.....	x
Abstract.....	xii
Chapter 1: Introduction.....	1
1.1 Motivation and problem statement.....	1
1.2 Scope of this thesis	4
1.3 Anticipated contributions of the thesis	5
1.4 Organization of the thesis.....	6
Chapter 2: Post-Amputation Rehabilitation and Gait Analysis.....	8
2.1 Amputation techniques.....	8
2.2 Prosthesis, prosthetic socket, and prosthetic feet	11
2.3 Anatomy of the lower human body	14
2.4 Human gait cycle.....	15
2.5 Gait analysis	17
2.6 Gait analysis for people with transtibial amputation.....	19
2.7 Prosthetic activity monitors (PAM's).....	20
2.8 Measurement of RSI Forces	23
2.9 Measurement of EMG	25
2.10 Framework for experimental gait study used in this thesis	27
2.10.1 Criteria for subject selection.....	27
2.10.2 Protocol for Clinical Study.....	27

Chapter 3: Residuum Muscle Activity in Transtibial Osteomyoplastic Amputation and	
Traditional Amputees	29
3.1 Introduction	30
3.2 Methods	32
3.2.1 Subjects.....	32
3.3 Experimental procedure.....	33
3.3.1 Gait activities.....	33
3.3.2 Data analysis.....	34
3.3.3 Hypothesis tests.....	34
3.4 Results and discussions	35
3.4.1 Residual muscle activation in TOA subjects.....	35
3.4.2 Residual muscle activation in TTA subjects	38
3.4.3 Special case	40
3.5 Limitation of the study	42
3.6 Conclusion.....	42
Chapter 4: Relationship between Gait Related Activity in Residual and Intact muscles	
and RSI Force	44
4.1 Introduction	44
4.2 Objective and Hypothesis.....	46
4.3 Methods:	47
4.3.1. Subjects:	47
4.3.2. Protocol.....	48
4.3.3 Data Analysis.....	50

4.4 Results	51
4.4.1 The relationship between muscle activity and gait in the amputated limb	51
4.4.2 The relationship between muscle activity and gait in the intact limb	52
4.4.3 The relationship between peak distal loading and gait.....	52
4.5 Discussions	56
4.5.1 Muscle contraction and activation profiles.....	56
4.5.2 Muscle activation and its relationship with type of gait.....	56
4.5.3 Peak Distal Force and its relationship to gait	57
4.6 Conclusions	57
Chapter 5: Conclusions and Scope of Future Work	59
5.1 Conclusions	59
5.2 Limitations and Scope of Future work	60
References	62

List of Tables

Table 2.1 Performance parameters of the force sensors [67].	24
Table 3.1 Demographics of the subjects; L- Left, R-Right	32
Table 3.2 ERMS for Tibialis Anterior in TOA subjects during selected gait activities .	37
Table 3.3 ERMS for Gastrocnemius in TOA subjects during selected gait activities ...	37
Table 3.4 ERMS for Tibialis Anterior in TTA subjects during selected gait activities.	38
Table 3.5 ERMS for Gastrocnemius in TTA subjects during selected gait activities ...	38
Table 4.1 Demographics of the subjects; L- Left, R- Right	48
Table 4.2 Maximum ERMS for TA, GA, and RF muscles of the amputated limb and their relationship to gait	54
Table 4.3 Maximum ERMS for TA, GA, and RF muscles of the intact limb and their relationship to gait	54
Table 4.4 Peak Distal force during Self-Selected and Brisk Gait	55
Table 4.5 Peak Distal force during Brisk and Weight Carry gait	55

List of Figures

Figure 2.1 Radiograph of the residual limb of a transtibial osteomyoplastic amputation [17].	10
Figure 2.2 a) SACH foot; b) Single axis foot; c) Multi- axial foot [29].....	12
Figure 2.3 a) Ossur® Variflex XC Rotate; b) ERS foot [29]	13
Figure 2.4 a) Eraize foot [40]; b) ProPrio foot [15]; c) emPOWER foot [16]	13
Figure 2.5 Lower body muscle anatomy [42].	14
Figure 2.6 Human gait cycle [44].....	15
Figure 2.7 a) SAM [60]; b) Smart Pyramid [61]	21
Figure 2.8 MiniSun IDEAA [62-63]	22
Figure 2.9 OU PAM [63].....	23
Figure 2.10 a) Placement of Force sensors inside the socket b) Amplifier circuit for the force signal [63].....	24
Figure 2.11 SEMG Placement along the residual muscle of an amputee [63].....	26
Figure 2.12 SEMG Amplification circuit [63].	26
Figure 3.1 Normalized Tibialis Anterior and Gastrocnemius muscle activity in intact individuals (reproduced using data in Table 5.22 and Table 5.24 from the Appendix in Winter [81]).	30
Figure 3.2 Normalized EMG for residual TA, residual GA, Intact TA, and Intact GA for three gait types in a TOA subject	36
Figure 3.3 Normalized EMG of residual TA, residual GA, Intact TA, and Intact GA for three gait types in a TTA subject	39
Figure 3.4 Normalized muscle activity in a Natural bridge amputee	41

Figure 4.1 Normalized Tibialis Anterior, Gastrocnemius and Rectus Femoris muscle activity in intact individuals (reproduced using data in Table 5.22 and Table 5.24 from the Appendix in Winter [81])45

Figure 4.2 a) Placement of the distal force sensors inside the prosthetic socket b) Placement of the surface EMG electrodes along the residual TA muscles49

Figure 4.3 Normalized EMG signals for TA, GA, and RF muscles during all three types of gait53

Figure 4.4 Mean distal force for a TOA subject during all three gaits55

Abstract

Causes of transtibial (below knee) amputation vary from traumatic events such as accidents to vascular and circulatory disorders. Following amputation, the individual is fitted with a prosthetic device in order to regain mobility. However, the extent of recovery depends on factors such as prosthetic socket fit, functionality of the prosthetic device, the type of amputation and the individual's health. Prior research was undertaken to study the asymmetry in gait, energy consumption and muscle activity in intact muscles of traditional amputees. Recently, research into residual muscle activity and residuum socket interface force in amputees with transtibial osteomyoplastic amputation has been undertaken. However, very little research has been undertaken to compare the residual muscle activation in unilateral transtibial traditional amputees and in those with unilateral transtibial osteomyoplastic amputation. Furthermore, the correlation between residual muscle activation, residuum socket interface force and the type of gait in individuals with unilateral transtibial osteomyoplastic amputation has never been studied. Study of residuum socket interface forces and residual muscle activity is important because these two parameters have been linked to factors that increase the risk of injury to the residual limb. Furthermore, study of residuum socket interface force helps a prosthetist better understand the loading in the prosthetic socket during gait and helps in achieving better prosthetic socket fit. Study of residual muscle activity patterns also helps in determining the effect of amputation on residual muscles and in turn on the health of the individual. Transtibial osteomyoplastic amputation is known to provide the amputees with distal end weight bearing and restoring the length tension relationship in the residual muscles and has been verified in the previous

studies. However, a comparison between results observed after transtibial traditional amputation and transtibial osteomyoplastic amputation have never been studied. Such comparative studies provides insight into the type of prosthetic design that best suits each type of amputation and also provides a better understanding of advantages and disadvantages of each type of amputation.

Gait is an important factor that affects residuum socket interface force and residual muscle activation. Study of the dependence of both these factors on the type of gait is of importance to develop better rehabilitation techniques and improve the performance of prosthetic devices.

In this thesis, the residual muscle activation in transtibial osteomyoplastic amputees and transtibial traditional amputees is looked at. For this purpose, 10 transtibial osteomyoplastic amputees and 4 transtibial traditional amputees were recruited for the study. This would help in realizing the effect of amputation on residual muscle activity and lays the foundation for understanding the effect of amputation on residual limb health. We expect to see considerable residual muscle activity in the transtibial osteomyoplastic amputees and minimal or random muscle activity in transtibial traditional amputation. Furthermore, the co-relation between residuum socket interface (RSI) force and EMG to the type of gait is studied in transtibial osteomyoplastic amputees. For this purpose, 10 transtibial osteomyoplastic amputees were recruited for this study. We expect to see increasing RSI force and EMG activity while comparing self-selected gait, brisk gait and weight carry gait. This would help establish a co-relation between RSI force and EMG activity laying foundation in developing better rehabilitation techniques and prosthetic devices.

Chapter 1: Introduction

1.1 Motivation and problem statement

Amputation of the lower extremities of an individual is usually prescribed as a result of traumatic injuries or to address complications arising from vascular disorders. Following the amputation, the individual is fit with a prosthetic limb and then undergoes rehabilitation. Unfortunately, in spite of advances in medicine and technology, many of these individuals regain only limited mobility and endure years of pain and complications arising from the use of prosthetic limb. An estimated 1.6 million people are living with a limb loss in the United States alone as of 2005 [1]. Some studies have estimated that about 185,000 people are undergoing amputation in either lower limb or upper limb every year [2], and if left unchecked this total number is expected to double to 3.6 million by 2050 [1]. Transtibial amputation, commonly known as ‘below knee’ amputation, is one of the most frequently performed procedure among all major limb amputations [3]. Studies of wounded servicemen have shown that one of the leading causes of amputation of lower limbs is trauma arising from accidents. In such cases, 41.8% of those sustaining lower limb injuries undergo amputation below the knee, while 35.4% undergo transfemoral or above knee amputation [4]. Irrespective of the cause, loss of a limb to amputation is a life altering condition. After amputation, the individual is fitted with a prosthetic limb and undergoes rehabilitation and physical therapy. The prosthetic limb comprises of three major parts namely, socket, foot, and connecting pylon or shaft. The socket is designed to snugly fit the residual part of the amputated limb and helps transfer the individual’s weight to the prosthetic foot during locomotion. Depending on the mechanism for the transfer of

weight, these sockets are classified as Patellar Tendon Bearing (PTB) socket or Total Surface Bearing (TSB) socket. The PTB socket is designed such that the majority of the individual's weight is transferred through the Patellar Tendon and muscle tissue in the popliteal area of the residual limb. This design restricts the weight transfer through muscles and soft tissues that are pressure tolerant. In contrast, the TSB socket is designed to enable the individual's weight to be transferred evenly over the entire surface of the residual limb. A socket liner is usually worn by the individual to improve the fit of the socket and cushion the residual limb. In case of TSB socket, a gel liner with a protruding pin at the distal end is employed with the pin being used to lock the liner with the socket. The foot typically consists of an ankle and a keel for balance and weight bearing during gait. The foot used can be broadly classified into three types namely, conventional feet, dynamic response or energy storage feet, and computer controlled feet depending on its construction. The foot is attached to the socket by a shank or a pylon.

Amputation is a traumatic event and has a significant impact on the life of the individual. In order to regain healthy, active lifestyle and promote limb health, it is important for the artificial limb to function as close to normal human limb as possible. Unfortunately, most the prostheses on the market are passive and designed primarily for weight bearing and not for regaining mobility. Further, due to the difference in the performance of artificial and natural limb, amputees tend to prefer their intact limb during gait leading to asymmetry in gait [5-6] and increased strain on the intact limb [7-8]. This tendency to favor intact limb during locomotion can lead to degenerative changes such as osteoarthritis of the knee and/or the hip joints of the intact limb. The

asymmetry in gait can also lead to osteopenia, i.e. bone loss, and secondary osteoporosis - a condition in which bones tend to become weaker and brittle [9].

Transtibial amputees often experience chronic back pain as a result of improper prosthetic fit. Apart from musculoskeletal damages, improper prosthetic fit can also lead to skin problems such as irritant contact dermatitis and pressure sores on residual limbs [10].

In addition to the performance of the prosthetic limb, the fit and comfort of the socket also play a significant role in the ability of the individual to regain normal gait.

Incorrect or improper fit of the socket can result in excessive pain as well as chaffing and sores in the residual limb of the individual. These effects can lead to secondary problems over time, especially in individuals with diabetes or vascular disorders.

Reduced mobility in these individuals can lead to obesity and other health complications further affecting their quality of life.

Previous studies reported in literature have indicated that even though most of the amputees use some form of prosthetic device, a majority of the users are not satisfied with the fit and comfort of the prosthetic socket and experience phantom pain and skin problems in the residual limb [11]. Several researchers have studied the asymmetry in gait between the intact limb and the residual limb of amputees, and the effect of different components on the performance of amputees [5-6, 12-14]. In recent years, manufacturers have also developed bionic feet such as Proprio foot [15] and BIOM [16] to enable the amputee to regain gait that is close to human gait. However, the effect of these devices on the gait of the individual and the long term benefit to health are unclear and the subject of ongoing research. Such research focuses on the extraction and

examination of gait parameters such as temporal-spatial parameters (TSP's), gait kinematics, kinetic measurements, muscular measurements, and energy expenditure. Research at the University of Oklahoma [17, 18] has also demonstrated the importance of studying the residual socket interface (RSI) forces and electromyographic (EMG) signals representing muscle activity in the residual limb during gait to determine the functional ability of amputees during locomotion. This research has demonstrated the importance of studying both the gait parameters as well as RSI and EMG data to adequately evaluate the ability of below-knee amputees to carry out normal work-related activities.

1.2 Scope of this thesis

This thesis aims to collect and analyze gait parameters as well as residual muscle activity and residual socket interface force in order to study the gait of people with amputation of their lower extremity. Three different gaits, self-selected pace, brisk, and weight carrying, that are commonly observed during normal work activities are considered and these parameters are collected from research participants over a period of two years. The collected data is studied to determine the dependence of these parameters on the selected gait of the individual. Further, changes observed over time in the collected data are studied to identify any changes in limb health. The following are the key steps in the process adopted for this thesis

- The prosthetic socket used by individuals who have undergone unilateral transtibial osteomyoplastic amputation will be instrumented with sensors and will be used in conjunction with a prosthetic activity monitor developed at the University of Oklahoma (OU-PAM) to collect gait data during work related activities. Algorithms

will be developed to analyze the collected data and determine the dependence of the gait parameters of the selected gait.

- EMG data collected during different types of gait will be used to study the effect of type of amputation on the residual muscle activity in a transtibial amputee. Results of this study will be used to lay the foundation for further investigations into the effect of muscle activity on the health of the residual limb.
- Finally, the dependence of activity in residual and intact muscles on the gait activity will be studied. Furthermore, the relationship between the Prosthetic Socket Interface (PSI) force and the type of gait will also be studied.

This thesis is presented in three parts. Below-knee amputation procedures and types of prosthetic feet and gait monitoring devices that are available in the market are covered in the first part of the thesis. In the second part, a comparative study on the effects of the type of amputation on the residual muscle activity will be presented. In the third part of the thesis, the relationship between the residual muscle activity and PSI force in TOA subjects with respect to gait will be investigated. Hypothesis tests will be carried out to further validate the results of the study. Furthermore, changes in residual muscle activity and distal loading in the residual limb in TOA subjects over a period of time will be investigated. It is anticipated that the results of this investigation will help in identifying the benefits of TOA amputation in the long run and aid in building prosthesis with better performance compared to those available in the market.

1.3 Anticipated contributions of the thesis

Verification of previous findings on results of TOA amputation on residual muscle activity.

In this thesis, the previous findings on residual muscle activity in TOA subjects will be verified. The co-contraction of Tibialis anterior (TA) and Gastrocnemius (GA) in TOA subjects during gait will be verified. The finding on distal loading of the residual limb in the socket will be verified.

b) Better understanding of the effects of type of amputation on residual muscle activity.

There are different methods of transtibial amputation that a surgeon can use during the surgical process. However, the effects of surgery on the residual muscle activity has been rarely looked at. In this thesis, the effect of amputation procedure on the residual muscle activity will be investigated. By performing a comparative study we hope to ascertain the advantages and disadvantages in terms of residual muscle activity and lay foundations for further study of residual muscle health as a result of different amputation procedures.

c) Identify the correlation between residual muscle activity and PSI force as a function of gait activities

Different gait activities cause muscles to fire at different instants and at different magnitudes. This holds true for residual muscles after amputation as well. PSI force in amputees is an additional measurement for the subjects compared to an intact subject and provides us a unique insight into the effectiveness of the socket interface and the prosthesis itself. In this thesis, relationships between residual muscle activity and PSI force with respect to gait will be established.

1.4 Organization of the thesis

The thesis is organized as follows.

- Chapter 2 contains background research undertaken for this thesis. It includes human gait cycle, types of amputations and prosthesis, gait analysis, electromyography measurements, residual socket interface force, residual muscle contractions, prosthetic activity monitors etc. Furthermore, criteria for subject selection and protocol for the study are described in this chapter.
- In Chapter 3, Residual muscle activation in subjects with TOA and CA amputations is described. Furthermore, previous findings regarding the muscle activation in TOA subjects is also verified.
- Chapter 4 discusses the relationships between residual muscle activity and type of gait and PSI force and type of gait. The consequences of these relationships are also further discussed in this chapter.
- Finally, in Chapter 5, conclusions and scope of future work are covered.

Chapter 2: Post-Amputation Rehabilitation and Gait Analysis

Gait analysis is an important tool in assessing the recovery and rehabilitation of the individual after amputation of lower extremities. In this thesis, only unilateral amputation of the leg below the knee is considered. Two commonly used amputation procedures and their effect on the function of the residual limb is studied. Post-surgical fitting of prosthetic foot and rehabilitation are discussed. Typical equipment used to study gait is presented and the use of these equipment's in evaluating the gait of the amputees is discussed.

2.1 Amputation techniques

The purpose of amputation has changed over time, from being a procedure to remove a damaged or diseased part of the anatomy to a reconstructive procedure aimed at restoring maximum functionality of the individual. While surgical techniques are being developed to aid the process of restoring full functionality [19, 20], it is equally important to verify the effectiveness of the surgery. Transtibial amputation is by far the most common among major limb amputations. Causes for lower limb amputation vary from peripheral vascular disease (PVD), trauma, tumors, infections and congenital limb deficiency [21]. There are different types of surgical techniques used for transtibial amputation. Based on the procedure and the desired outcome, these techniques can be classified as follows [22]:

1. Closed amputations,
2. End weight bearing amputations, and
3. Open amputations.

Closed amputations are the most common form of transtibial amputations. There are many different techniques that fall under this category. Long Posterior Myofasciocutaneous flap, Equal Anterior and Posterior flaps, Equal Medial and Lateral (Sagittal) flaps are examples of closed amputations. For the sake of convenience, all the closed amputations are lumped together as Traditional Transtibial Amputation (TTA). In traditional transtibial amputation, the cut ends of the tibia and the fibula bones are left exposed and these two bones are stabilized by a screw. Furthermore, the residual muscles (tibialis anterior and gastrocnemius) are left disconnected at the distal end of the limb resulting in a loss of length-tension relationship in these muscles which in turn leads to decreased muscle contraction, blood circulation and gait performance [22]. The open end of the tibia and the fibula prevent any weight bearing at the distal end of the residual limb.

In an end bearing amputation, the amputation is performed in such a way that the distal end of the residual limb can bear weight without causing pain. Ertl Osteomyoplastic amputation, Singer procedure are examples of end bearing amputations. Our primary focus in this thesis is the Transtibial Osteomyoplastic amputation (TOA) (Ertl Osteomyoplastic amputation). This procedure was initially designed as a revision procedure for the war wounded [23]. In this type of amputation, two osteoperiosteal sleeves from the tibia are sewn to the fibula forming a tube-like structure between the two bones at the distal end. This structure ossifies to form the bony bridge between the two bones creating a surface for end weight bearing. Furthermore, the residual muscles are sutured to each other and reattached to the bony foundation restoring the length tension relationship in the muscles [23]. Apart from being able to support part of the

body weight at the distal residuum, the bony bridge also functions to stabilize the anatomy of the lower limb [24]. Figure 2.1 shows a radiograph of the residual limb of an amputee that underwent the TOA procedure.



Figure 2.1 Radiograph of the residual limb of a transtibial osteomyoplastic amputation [17].

After traditional transtibial amputation, individuals are fitted with a patellar tendon bearing (PTB) socket, in which the weight loading is concentrated at the anterior area under the knee cap. This concentrated loading results in the formation of sores and pain in the knee and hip joints. On the other hand in TOA, the amputees have end weight bearing capabilities and thus are fitted with Total surface bearing (TSB) sockets, where the loading is evenly distributed at the distal end mitigating the problems faced with PTB sockets. Previous studies have shown the TOA procedure to cause a reduction in the incidence of sores seen with PTB sockets [25]. Research has also been undertaken in recent years to validate the effectiveness of the TOA procedure [17-18, 26-27].

However, a comparative study of the outcomes of the TOA procedure and traditional transtibial amputation techniques is yet to be undertaken. Furthermore, no research has been undertaken in order to find out whether the benefits of the TOA procedure are long-lasting or if there are any significant changes in the residual and intact limbs over time.

2.2 Prosthesis, prosthetic socket, and prosthetic feet

Lower limb prostheses have come a long way from wooden legs and prosthetic limbs today are intelligent and can adapt to gait. However, even with the current development, they are nowhere close to replicating a fully functional limb. The lower limb prosthesis contains three main parts, namely prosthetic socket, shank and the foot. Prosthetic feet can be classified into three categories: conventional feet, dynamic response feet (energy storage feet), and microprocessor/computer controlled feet [28]. Solid Ankle Cushioned Heel or SACH foot, Single axis foot and multi-axial foot (Figure 2.2) are some of the widely used foot designs. These feet are designed to primarily support body weight and have minimal functionality. The SACH foot, for example, consists of a rubber cushion and foam instead of an ankle. This restricts the function of the foot to supporting the weight of the individual. The single axis foot, on the other hand, has an ankle joint that is limited to movement in the vertical direction. Multi-axial feet provide movement in both the horizontal and vertical directions making them the most flexible among the conventional feet. However, this foot doesn't store and return energy during gait, thereby increasing the effort required by the user during normal gait. Though limited in functionality these conventional feet are widely used in rural areas and third world countries on account of their low cost and easy maintenance.



Figure 2.2 a) SACH foot; b) Single axis foot; c) Multi- axial foot [29].

Dynamic response feet or energy storage and return feet (ESR) (Figure 2.3) were developed to store energy like a spring. These feet store energy during the loading response phase of the gait cycle and release the energy during the preswing period thus helping to propel the individual forward. While the design of ESR would suggest a reduction in energy usage, research into the energy advantage of these feet has been inconclusive. Some studies have shown that ESR does provide a substantial improvement in terms of energy expenditure [30-31], while others contend that ESR does not provide any significant improvement over SACH foot [32, 33].

Advanced prosthesis such as microcontroller/computer-controlled prosthetic feet (Figure 2.4) have been developed in recent years to help the foot adapt to different gaits and terrains. These devices either use pneumatic actuators or electric actuators to generate the torque required for propulsion and ankle movement. Some of the major drawbacks include daily charging of the built-in battery, increased cost and increased the weight of the prosthesis. Studies have shown that despite the increase in weight of the powered prosthesis compared to ESR these prosthetic foot lead to lower metabolic energy expenditure by the user [34].



Figure 2.3 a) Ossur® Variflex XC Rotate [35] b) ERS foot [29]

Studies have also reported finding improved gait performance in users while using powered prosthesis [36-37]. Several researchers are also looking into improving bionic feet in terms of ankle movement and push-off power during gait. Few prototypes of such research include SPARKy [38] and PPAMs [39].



Figure 2.4 a) Eraize foot [40] b) ProPrio foot [15] c) emPOWER foot [16]

Prosthetic feet play a key role in gait performance of an amputee. Thus, it is important to undertake research to determine the effects of prosthetic feet in gait performance of an amputee. Previous studies on prosthetic feet varied from energy expenditure of an individual with different feet [34] to effects of different feet on residuum socket interface force of an amputee [41]. In the next section, a brief description of the

anatomy of the lower human body and its impact on the gait is provided. Later, the changes seen as a result of transtibial amputation and their impact on gait is presented.

2.3 Anatomy of the lower human body

Human gait is powered by the firing of the lower limb muscles. Thus the study of muscle activation is an important part of gait analysis. The lower body muscle anatomy of human beings is shown in Figure 2.5 [42]. For this study, only 3 muscles are of interest namely, Tibialis Anterior, Gastrocnemius and Rectus Femoris. The tibialis anterior is present along the anterior side of the lower leg along the tibia (shin bone). The gastrocnemius is also called the calf muscle and is on the posterior side of the lower limb below the knee joint. Finally, the Rectus Femoris is a part of the Quadriceps muscle group (Thigh muscles group) and is found on the anterior side of the upper leg. The activation of these muscles during gait is discussed in the next section.

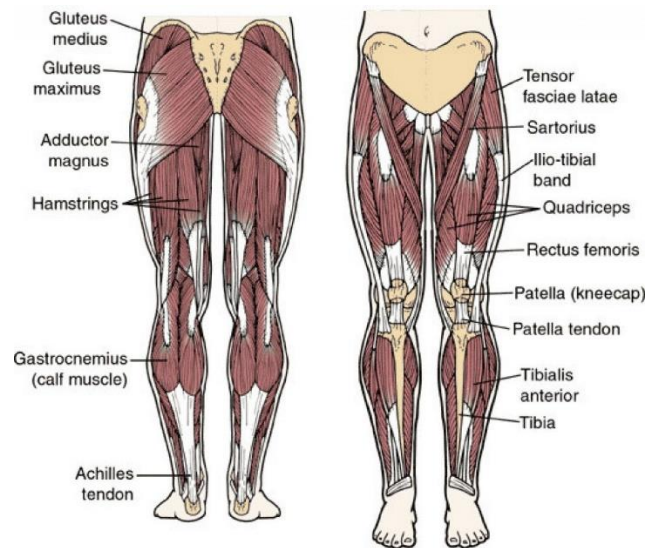

Figure 2.5 Lower body muscle anatomy [42].

2.4 Human gait cycle

Bipedalism is a highly complex form of locomotion that has evolved in several stages and is unique to hominins [43]. Any locomotion that requires periodic loading and unloading of limbs for movement can be called a gait. Thus, gait as a broad term encompasses walking, running, skipping etc. Walking is by far the most frequently used gait and will be the focus of this thesis. Furthermore, in this thesis, the word gait will only refer to walking, and variations in the gait will be labeled appropriately. A typical human gait cycle is shown in Figure 2.6 [44]. The cycle can be divided into two main parts the ‘Stance Phase’ and the ‘Swing Phase’ [45].

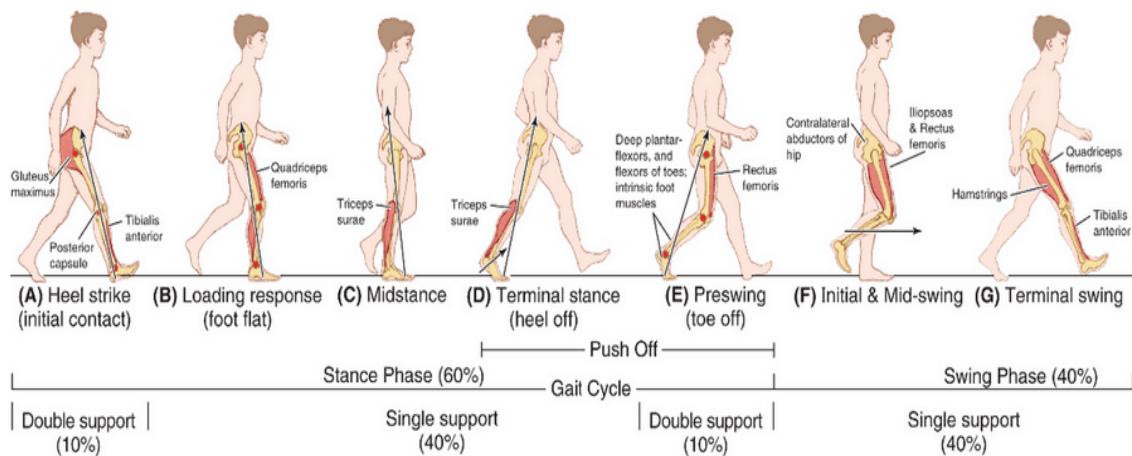

Figure 2.6 Human gait cycle [44]

A typical gait cycle starts with initial contact (Heel strike) (0%) of one foot and ends at the next contact of the ipsilateral foot (same foot) (100%) which would also be the initial contact for the next cycle. It can be seen from Figure 2.6 that stance phase of the gait cycle is approximately 60% of the whole cycle. This phase can be further divided into five sub-phases namely, Initial contact, Loading response, Mid-stance, Terminal stance, and Preswing. The swing phase constitutes of the remainder of the gait cycle and

can be further divided into two -phases namely, Initial and Mid-swing, and Terminal swing.

The Initial contact is the point in which the heel of the leading foot come into contact with the ground, hence the name heel strike. This phase is also called the double support phase and constitutes 10% of the gait cycle. During this period, both the feet are in contact with the ground. This action is accompanied by a shift in body weight from the contralateral foot (other foot) to the leading foot and the activation of Gluteus maximus and Tibialis anterior muscles. The initial contact is accompanied by the loading response (Foot flat) in which the whole weight transfer is completed to the ipsilateral foot and the foot is in complete contact with the ground while the Contralateral foot proceeds with toe off during this period. The Quadriceps femoris (Quads) are active during this period. The mid stance period quickly follows the loading response wherein the contralateral foot proceed with the swing. This period ends when the contralateral foot is aligned with the ipsilateral foot. During this period the triceps muscle group remains active. The terminal stance period (a.k.a. heel off) is when the heel of the ipsilateral foot comes out of contact in preparation for the second weight transfer to the contralateral foot. This period is accompanied by sustained activity from triceps muscle group from the mid stance phase. The three phases, loading response, Midstance, Terminal Stance, combined together are known as Single support phase and comprise 40% of the gait cycle. As the name suggests during this period only the ipsilateral foot is in contact with the ground. The final period of the Stance phase is the Preswing period during which the ipsilateral foot is ready for toe off and the contralateral foot is at the initial contact stage leading to the weight transfer from the ipsilateral to the

contralateral foot. This period again is a double support period during which both the feet stay on the ground and contribute to 10% of the gait cycle. The Rectus Femoris (Part of Quad muscle groups) remains active during this period.

The swing phase of the cycle starts with the end of the Preswing period with the ipsilateral foot is off the ground and the weight transfer is completed to the contralateral foot. This period is known as the Initial and mid-swing period. During this period the Rectus Femoris and the contralateral abductors of the hip remain active. This period is followed by the Terminal swing during which the ipsilateral foot is about to come into contact with the ground and ends when the ipsilateral foot makes initial contact leading to the next gait cycle. During this phase the Quads, Hamstrings and the Tibialis anterior muscle are active. This period is also as Single support phase as only the contralateral foot is in contact with the ground during the whole period.

2.5 Gait analysis

Gait analysis can be defined as the study of locomotion of legged organism. Previous study recommended that gait analysis be used to detect abnormalities in gait and aid in the rehabilitation of people with disabilities [46]. Based on the methods used, gait analysis can be classified as:

1. Qualitative analysis, and
2. Quantitative analysis.

Qualitative analysis: This type of analysis is based on visual or qualitative interpretation of gait and is often unreliable [47]. However, qualitative analysis may serve as a preliminary guide for selecting the type of quantitative analysis to be performed.

Quantitative analysis: This type of analysis is an objective assessment wherein, certain quantities are measured with the help of sensors and Data Acquisition Systems (DAQ's), and an assessment is made. Quantitative measurement involves one or more of the following parameters.

- Temporal-Spatial parameters: Temporal-spatial parameters consist of speed and time measurements of gait. These parameters are measured with the help of foot switches, stopwatch, pressure mats etc. The most common parameters are step length, stride length, cadence, walking speed and double support. These parameters are the most commonly used parameters in the study of the gait of an individual.
- Kinematic parameters: Kinematic parameters include analysis of gait in terms of joint displacements, velocities accelerations of joints and body segments. Data is captured using cameras and the joints are identified with the help of markers. Kinematic gait measurements can be done in 2 dimensions or 3 dimensions depending on the equipment available and the requirement of the study. Traditionally, these kind of measurements are performed on able-bodied persons, but some research in amputee gait has also been performed by studying these parameters [32, 48]. These kind of measurements provide only a partial insight into the gait of the amputee as the cameras do not have the capabilities to record the activity inside a prosthetic socket. Thus extra DAQ's are required to capture the activity inside the prosthetic socket so as to completely analyze the gait of an amputee.
- Kinetic Gait measurements parameters: In these measurements, actual forces involved in the gait are measured. These include Ground reaction Force (GRF), Joint moments, Plantar Pressure measurements, and muscle activations. These measurements

are obtained using force plates, pressure sensors, accelerometers, and Electromyography (EMG) electrodes. For Intact individual forces are measured at the bottom of their feet while for an amputee forces are also measured inside the prosthetic socket. These measurements are useful in identifying the source of abnormalities in the gait of an individual.

- **Energy Expenditure:** Energy expenditure refers to the energy spent by an individual during ambulation. This measurement plays an important role in the analysis of an amputee as energy consumption plays a crucial role in the performance of the prosthesis. Thus many research studies have used the measurement to compare the efficiency of ambulation using different prosthetic feet [34, 49-50]. It should be noted that this measurement, however, does not provide any particular insight into gait abnormalities if present.

For this thesis, kinetic gait parameters i.e. Residuum socket interface forces and EMG signals, of Transtibial amputees are studied. These measurements are recorded using a Prosthetic activity monitor (PAM) and few commercially available PAM's are discussed in Section 2.7.

2.6 Gait analysis for people with transtibial amputation

Gait analysis provides insight into the characteristics of locomotion and the performance of joints and muscles during gait. Depending on the parameters of interest different gait monitoring devices can be used to collect parameters such as temporal-spatial parameters, kinematic gait measurements, kinetic gait measurements and energy expenditure. Gait analysis of intact individuals helps with the betterment of prosthesis [51]. Gait analysis has been used in previous studies to investigate the effects of

amputation such as asymmetry in gait to higher energy expenditure [52]. Unlike the case of intact individuals, extra parameters such as residuum socket interface forces and residual muscle activity need to be studied under gait analysis. These parameters of the amputee subjects are compared to those of intact individuals to better understand the consequences of amputation on gait of an individual [53]. Furthermore, different parameters such as the type of prosthetic feet, fit of the prosthetic socket, and the type of amputation undertaken have an effect on gait. Some studies have looked at the effects of prosthetic feet on gait [41, 50] while others have looked at residual muscle activity and RSI force [18, 27]. Further study down this line will aid in better rehabilitation techniques for amputees and development of better prosthetics.

2.7 Prosthetic activity monitors (PAM's)

Several prosthetic activity monitors are commercially available for use in gait analysis. These devices capture steps and energy expenditure in a subject (both amputee and intact). For example, Ossur® [54] developed a PAM called patient monitoring device which could track the position of an amputee 1000 times per second with the help of combination of sensors. This device can measure step length, maximum speed, distance traveled, average speed, active time, and inactive time. The device also generates an activity index that can aid clinicians in comparing the performance of different individuals.

Another example of a prosthetic activity monitor is the StepWatch Activity Monitor (SAM) developed by Orthocare Innovations™ [55]. It is used to for long term assessment of gait of an amputee. The device records the number of steps taken over a period of two months. The company also markets other PAM's such as Galileo that uses

the step watch technology to collect data of an amputee's activity and displays it on a smartphone via the Galileo app. The app provides insight into the amputee's activity by providing statistical analysis of the data collected. The company also developed a device for measuring socket reaction forces called Smart Pyramid. This device helps in assessing the performance of the prosthesis over time. Previous studies have either looked into the validity of SAM [56, 57] while others used it in their studies to acquire data [58, 59].



Figure 2.7 a) SAM [60] b) Smart Pyramid [61]

For the research undertaken in this thesis, two PAM's were used. The first one is the Minisun™ IDEAA (Intelligent Device for Energy Expenditure and Physical Activity) [62]. This device records temporal-spatial parameters (Step length, Stride length, Stance time, Gait duration, Cadence etc.) with the help of foot switches and accelerometers. It comes with a software package that analyses the data collected and estimates the gait activity that was undertaken and the energy expenditure of the subject during the gait activity. It also provides a detailed summary of the activities undertaken to give the user a choice to choose between a single activity and multiple activities during the gait

period. It also provides EMG recording capability, which is not used for this study on this device.



Figure 2.8 MiniSun IDEEA [62-63]

The second PAM used for data collection in this thesis is the OU-PAM (University of Oklahoma Prosthetic activity monitor) [64]. OU-Pam is used to capture Residuum socket interface (RSI) force and EMG from muscles of the amputee's. It consists of signal conditioning and Data acquisition board along with two tubes which carry the cables that connect to the sensors inside the prosthetic socket. An Atmel® development board STK525 (8-bit microcontroller AT90USBxxxx) forms the core of the OU-PAM [65]. The Atmel® Extension board ATEVK525 that houses an SD-Card slot is used for writing data into the SD-Card for data storage [65]. The OU PAM has a data acquisition rate of 1000Hz which is sufficient to capture variations in EMG signals in real time. Furthermore, OU-PAM can capture data from up to 16 channels. 10 of these channels are used for capturing RSI force data and the rest are used to capture EMG data. All the three boards and the power source are enclosed in a box that can be strapped on as a backpack by the amputee thereby not hindering his motion during gait. Thus the data acquired using this PAM is not in a laboratory setting but rather in regular conditions.



Figure 2.9 OU PAM [63]

2.8 Measurement of RSI Forces

RSI force measurement plays a crucial role in the analysis of the prosthesis fit and functionality. Previous studies have shown that the factors that lead to increasing the risk of biomechanical residuum injury have also been linked to weight bearing forces at the distal end of the residuum prosthetic socket [66]. The residuum socket force is measured using the Flexiforce® A201 Piezo-resistive sensor [67]. Table 2.1 shows the electrical properties of the sensors [67]. The sensors are secured inside the prosthetic socket with the help of adhesive tape at specific locations inside the socket (Figure 2.10(a)). The sensors are <math><0.05\text{mm}</math> thin and do not result in any discomfort or change in the prosthetic fit. The sensors are calibrated each time before use. The force detected by the sensor is converted to voltage with the help of amplifying circuit shown in Figure 2.10 (b).

	Typical Performance	Evaluation Conditions
Linearity (Error)	< ±3%	Line drawn from 0 to 50% load
Repeatability	< ±2.5% of full scale	Conditioned sensor, 80% of full force applied
Hysteresis	< 4.5 % of full scale	Conditioned sensor, 80% of full force applied
Drift	< 5% per logarithmic time scale	Constant load of 111 N (25 lb)
Response Time	< 5μsec	Impact load, output recorded on oscilloscope
Operating Temperature	-40°C - 60°C (-40°F - 140°F)	Time required for the sensor to respond to an input force

Table 2.1 Performance parameters of the force sensors [67].

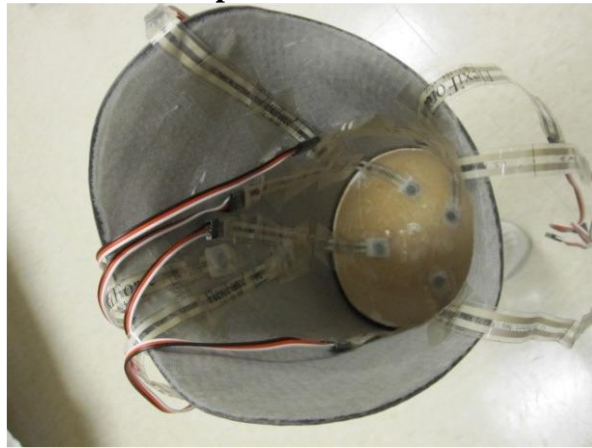

(a)

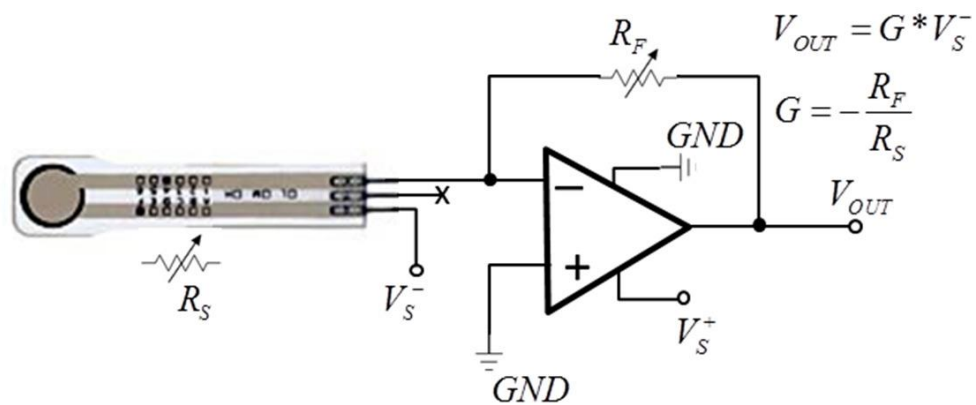

(b)

Figure 2.10 a) Placement of Force sensors inside the socket b) Amplifier circuit for the force signal [63]

2.9 Measurement of EMG

An Electromyogram is an electrical activity generated by the summation of many muscle unit activation potentials (MUAP's) from all the motor units active at a given time. These signals can be picked up either by the use of disposable surface stimulating and recording electrodes or by percutaneous fine needle electrodes inserted into the muscle belly [68]. Previous studies have shown that the residual muscle activity during active prosthetic used is linked to the factors that increase the risk of biomechanical residuum injury [66, 69]. Furthermore, the study of EMG signals can provide insight into how the muscular systems generate joint moments and stabilize limbs in both normal gait and pathological gait [45, 70]. Lastly, the study of EMG signals of residual muscle has been shown to have great potential in gait recognition and prosthetic development [71]. Thus studying changes in muscle activity and especially residual muscle activity is crucial. However until recently, studies have focused on the contraction of intact muscles in amputees as the study of residual muscles requires sensors with high sensitivity and with minimal thickness to enable placement inside the socket. Recently, with the change in the purpose of amputation from removal of injured body parts to a reconstructive procedure, a few studies have looked at the recovery of the residual muscles after amputation [72] and their functionality during gait [73-74]. For this thesis, disposable surface stimulating and recording Ag/AgCl electrodes with a sensing area of 1.44cm² are used [75]. These electrodes are placed on the muscle belly of the targeted muscles 2.5 cm apart longitudinally along the muscle (Figure 2.11). At the location of interest, the skin is prepped by shaving the area followed by cleaning

with alcohol and application of the conducting gel before the placement of Surface EMG (SEMG) electrodes.



Figure 2.3 SEMG Placement along the residual muscle of an amputee [63]

The magnitude of the signal picked up by the SEMG electrodes is small because of the low magnitude of the electrical activity of muscle activation and is of the order of 1mv. In order to capture and study these signals, an amplifier is used to amplify the magnitude of the signal [76-77]. The amplification circuit used in the OUPAM for this thesis is shown in Figure 2.12.

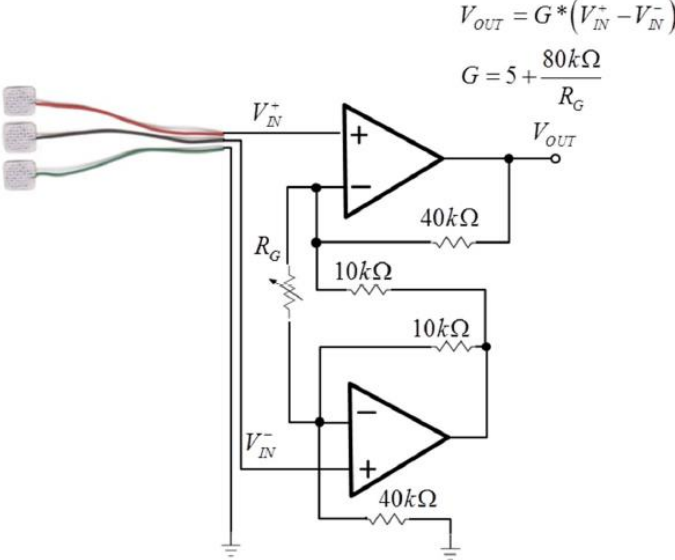

Figure 2.4 SEMG Amplification circuit [63].

2.10 Framework for experimental gait study used in this thesis

In this thesis, we try to address some of the shortcomings stated in the previous sections. The details of the experimental setup such as criteria for subject selection and protocol is discussed below in the subsections.

2.10.1 Criteria for subject selection

All the subjects for this study have been recruited from the unilateral transtibial amputee population residing in the state of Oklahoma. The amputees are required to have undergone the amputation procedure at least 6 months prior to the day of participation in the study. The subject age group varied from 18 to 64-year-olds. Furthermore, the study limits itself to the study of the male population. All the subjects are capable of walking independently without any help from assistive devices except their own prosthesis. The subjects are also required to be healthy i.e. free from all medical conditions such as diabetes, peripheral vascular, neuromuscular, inflammation, cardio-respiratory disorders. The subjects recruited needed to be English speaking and are capable of independently giving written consent to the participation in the study. Intact individuals were also recruited for this study to serve as a control group.

2.10.2 Protocol for Clinical Study

The protocols used in this study have been approved by the Institutional review board at the University of Oklahoma Health Science Center (OUHSC) for the protection of human subjects [78, 79]. All the subjects used their own prosthesis during the period of the study so that the data collected would be representative of their daily usage. A certified prosthetist was available on site for the whole duration of the study to ensure socket alignment and fit. Furthermore, data on heart rate, pulse, blood oxygen levels,

and the Borg index of participants was collected by the personnel's from the College of Allied Health, OUHSC.

The next two chapters will discuss the design and results of the individual experimental studies undertaken in this thesis. Each chapter is structured as follows

- Background: This part identifies the need for each study and states the motivation for the study.
- Objectives: This part discusses the objectives of the thesis and the hypothesis framed based on these objectives.
- Methods: This part includes information on subjects, protocol, and data analysis.
- Results and conclusion: Results from the study and the inference and conclusions drawn from those results are discussed in this part.

Chapter 3: Residuum Muscle Activity in Transtibial Osteomyoplastic Amputation and Traditional Amputees

The relationship between the activity of the muscles in the lower extremity and the health of an individual has been widely studied [80, 25]. In addition to their effect on the gait of the individual, the elongation and contraction of these muscles play an important role in pumping blood back to the heart and in the overall health of the vascular system. Following the amputation of the lower limb, the tibialis anterior and the gastrocnemius muscles are trimmed and left unattached in the residuum. As a result, the length-tension relationship in these muscles are lost and the functioning of these muscles is compromised. TOA procedure aims to rectify this by attaching the gastrocnemius and the tibialis anterior muscles together at the distal end of the limb to retain the length-tension relationship. However, the functioning of these muscles in both TTA and TOA amputees has not been extensively studied in the literature. In this chapter, the activity of residual muscles in individuals with osteomyoplastic amputation and traditional transtibial amputation will be investigated. Electromyographic (EMG) signals obtained using surface EMG electrodes are used to monitor the muscle activity and correlate these with the gait of the individual. A total of 14 subjects were used in the study reported in this Chapter with four of the subjects having undergone traditional amputation and the rest having undergone osteomyoplastic amputation. The activity of the residual muscles, i.e. tibialis anterior and gastrocnemius, is captured and compared to that of the corresponding muscles of the intact limb for both the subject groups. In order to determine the effect of the amputation procedure and gait in the functioning of these muscles.

3.1 Introduction

Electromyographic (EMG) signals obtained using surface or needle electrodes have been extensively used to study the activity patterns of TA and GA muscles during dorsiflexion and plantarflexion of ankle joint in intact individuals [81, 82]. The normalized mean EMG signal and the envelope of EMG values within ± 1 standard deviation of the mean for both the TA and GA muscles over a gait cycle is shown in Figure 3.1.

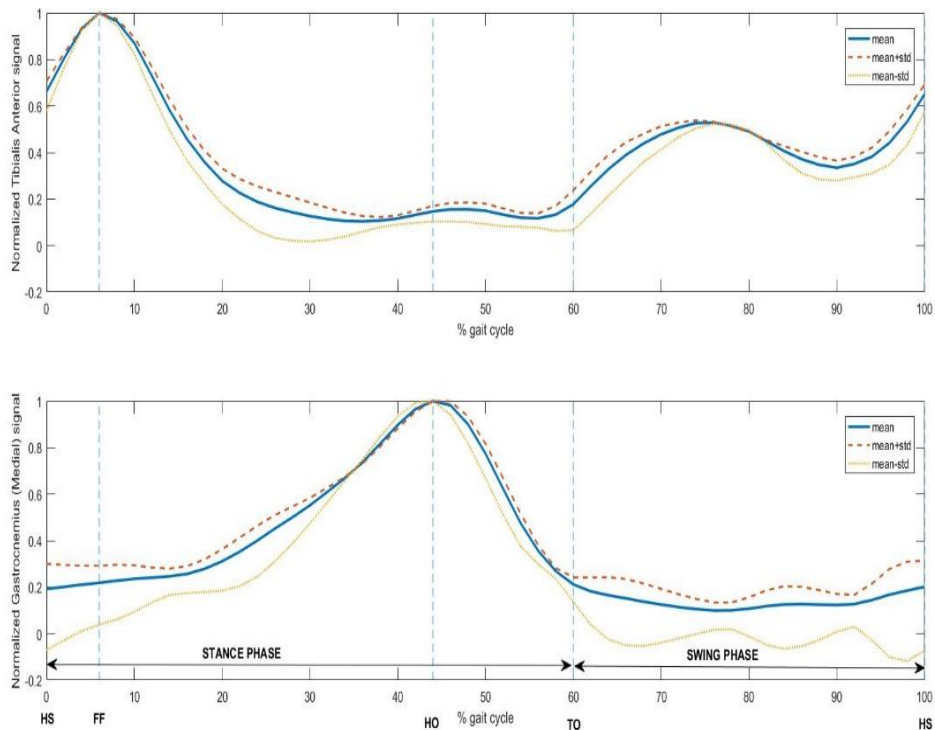

HS - Heel Strike, FF- Foot Flat, HO – Heel Off, TO - Toe Off.

Figure 3.5 Normalized Tibialis Anterior and Gastrocnemius muscle activity in intact individuals (reproduced using data in Table 5.22 and Table 5.24 from the Appendix in Winter [81]).

It can be seen that TA is most active during the initial phase of the gait cycle i.e. from Heel Strike (Initial Contact) to Foot Flat (i.e. during the Loading Response phase of the gait) and again during the swing phase. On the other hand, GA is active during the mid-stance period, peaking at Heel Off, and then decreasing rapidly till Toe Off. GA is inactive from the beginning of the swing phase to the mid stance of the following gait cycle. This activation pattern is also reported in Kirtley [82] (p 149-150).

In Traditional transtibial amputation, the TA and GA muscles are severed and are allowed to retract or are limited to reattachment of a single muscle. In the TOA procedure, the length-tension relationship is restored resulting in activation of muscles and better blood circulation [23]. It has been shown in previous studies that there is considerable muscle activity in the residual limb following the TOA procedure [18]. The study, however, did not address whether the muscle activity was unique to TOA subjects or whether significant muscle activity was observed in TTA subjects as well. This study is aimed at investigating the muscle activity in TOA and TTA subjects to determine whether 1) such activity significantly differs and 2) the activity is related to the gait. Healthy, able-bodied men are considered in this study and muscle activity in the residual limb is investigated during three types of gait, namely walking at a self-selected pace, walking at a brisk pace, and walking while carrying a load, encountered during normal daily activities. In both TOA and TTA populations, the EMG signal from the residual limb is compared with the corresponding values from the intact limb to determine if the muscle activity has altered as a result of the amputation procedure. The following two research questions are posed for the study.

- a) Is there significant TA and GA muscle activity in TOA subjects? If significant, is the muscle activity related to gait?
- b) Is there significant TA and GA muscle activity in TTA subjects? If significant, is the muscle activity related to gait?

3.2 Methods

3.2.1 Subjects

The experimental protocol adopted for this study was approved by the Institutional Review Board at the University of Oklahoma Health Sciences Center. Ten men with TOA and four men with TTA consented to participate in this study. The inclusion criteria for the study was that the subject had to be healthy, English-speaking, and capable of walking independently without any assistance or assistive devices. The demographics of the subjects are tabulated in Table 3.1. All the subjects used their own prosthetic legs during the test to ensure that the EMG values are representative of the values seen during their normal daily activities. A certified prosthetist was on hand to ensure socket fit.

SUBJECT	AMPUTATION TYPE	AMPUTATION SIDE	AGE (YEARS)	HEIGHT (IN)	WEIGHT (LBS)	LENGTH OF RESIDUAL LIMB (CM)
S1	TTA	L	51	72	218	8
S2	TTA	R	34	75	220	35.5
S3	TTA	L	23	71	194	14.5
S4	TTA	R	29	76	204	15.3
S5	TOA	L	50	72	270	18
S6	TOA	L	32	72	207	17
S7	TOA	R	27	72	200	19.5
S8	TOA	L	30	74	207	24
S9	TOA	L	53	69	160	16
S10	TOA	R	50	71	245	18
S11	TOA	L	38	72	175	16
S12	TOA	R	25	75	215	19
S13	TOA	R	45	67	198	27
S14	TOA	R	28	74	175	12

Table 3.1 Demographics of the subjects; L- Left, R-Right

3.3 Experimental procedure

The data for the study was collected using University of Oklahoma Prosthetic Activity Monitor (OU-PAM) [35]. The OU-PAM is equipped with an STK525 development board (consisting of the 8-bit AT90USB647 microcontroller) and an ATEVK525 extension board with an SD memory card [65]. The OU-PAM operates at 1 KHz frequency and captures analog signals on 16 different channels. Ten of the sixteen channels were used to capture force data inside the prosthetic socket and the remaining six channels were used to capture EMG data from three specific muscle groups (TA, GA and Rectus Femoris (not used in this study)) on both the intact limb and the residual limb. The force data was collected using FlexiForce® A201 piezoresistive sensor (Tekscan Inc, South Boston, MA) [67]. The EMG activities were recorded using disposable surface stimulating and recording Ag/AgCl electrodes [75]. The subjects were also equipped with a gait monitoring device called Intelligent Device for Energy Expenditure and Physical Activity (IDEEA® by MiniSun™ (Frenso,CA)) [62]. The force data was used to determine gait events and to synchronize EMG signals with respect to these events. The force signal was also used to validate experimental data with the data observed from the IDEEA® system.

3.3.1 Gait activities

During the test, each subject was asked to perform three tasks that are typically encountered during everyday activities. These tasks include:

- a) Walking at self-selected pace for a duration of 2 minutes (SG)
- b) Walking at brisk pace for a duration of 2 minutes (BG)

- c) Walking for a distance of 25 feet while carrying a load (LG). (The load is selected such that it does not cause undue exertion on the part of the individual.)

3.3.2 Data analysis

EMG signals have been widely used to study muscle activity in transtibial amputees during gait. EMG data collected during this study was processed according to the procedure specified in winter [70]. The EMG signal was rectified using a full wave rectifier and then filtered using a low-pass filter with 8Hz cutoff frequency. A symmetric moving window of 150 milliseconds duration was used to determine the Root Mean Square value of the EMG signal (E_{RMS}). The gait cycle was normalized to 100 data points and ten uniform intervals (10 data points each) were selected to represent the entire cycle [83]. The mean value of E_{RMS} ($\overline{E_{RMS}}$) on each interval was determined and used as an indicator of the muscle activity for that interval of the gait cycle. The maximum and minimum value of E_{RMS} ($\overline{E_{RMS_{Min}}}$, $\overline{E_{RMS_{Max}}}$) were also computed.

3.3.3 Hypothesis tests

Statistical tests were performed to determine any significant difference between $\overline{E_{RMS_{Max}}}$ and $\overline{E_{RMS_{Min}}}$ during the gait of the individual. A significant difference in these values would indicate significant muscle activity at the location. Two sample t-tests (two-tailed, paired, unequal variance, alpha = 0.05) were used to validate the following hypotheses.

H1: $\overline{E_{RMS_{Max}}}$ equals $\overline{E_{RMS_{Min}}}$ in residual TA for TOA subjects.

H2: $\overline{E_{RMS_{Max}}}$ equals $\overline{E_{RMS_{Min}}}$ in residual GA for TOA subjects.

H3: $\overline{E_{RMS_{Max}}}$ equals $\overline{E_{RMS_{Min}}}$ in residual TA for TTA subjects

H4: $\overline{E_{RMS_{Max}}}$ equals $\overline{E_{RMS_{Min}}}$ in residual GA for TTA subjects

In these tests, an ‘H’ value of zero indicates that the NULL hypothesis is accepted. On the other hand, H=1 indicates that the NULL hypothesis is rejected in favor of the alternate hypothesis, i.e., $\overline{E_{RMS_{Max}}}$ is not equal to $\overline{E_{RMS_{Min}}}$. Similarly, a p-value less than 0.05 will indicate that the corresponding muscle activity occurs with a confidence interval of 95%. On the other hand, a p-value > 0.05 will indicate a lack of appreciable muscle activity.

All the data analysis and hypothesis testing reported in this paper were done using routines implemented in MATLAB® (The MathWorks Inc, Natick, MA) [84].

3.4 Results and discussions

3.4.1 Residual muscle activation in TOA subjects

The average normalized EMG signals of all four muscle groups, namely TA and GA from both intact and residual limbs, for each gait activity, are shown in Figure 3.2. The signals were normalized with respect to the maximum EMG value observed among these four signals for each gait activity of a subject. The EMG signals in Figure 3.2 indicate that both the TA and GA muscles in the residual limb are active during all three gaits reported in this study. This finding is in agreement with previous studies which have shown that there is residual muscle activity in TOA subjects [85-86]. It can also be seen that TA is active during the loading phase (0-10% of the gait cycle) and during the swing phase for all three gait types considered in this study. While the GA muscles are active, the activation is different from that observed in the GA in the intact limb.

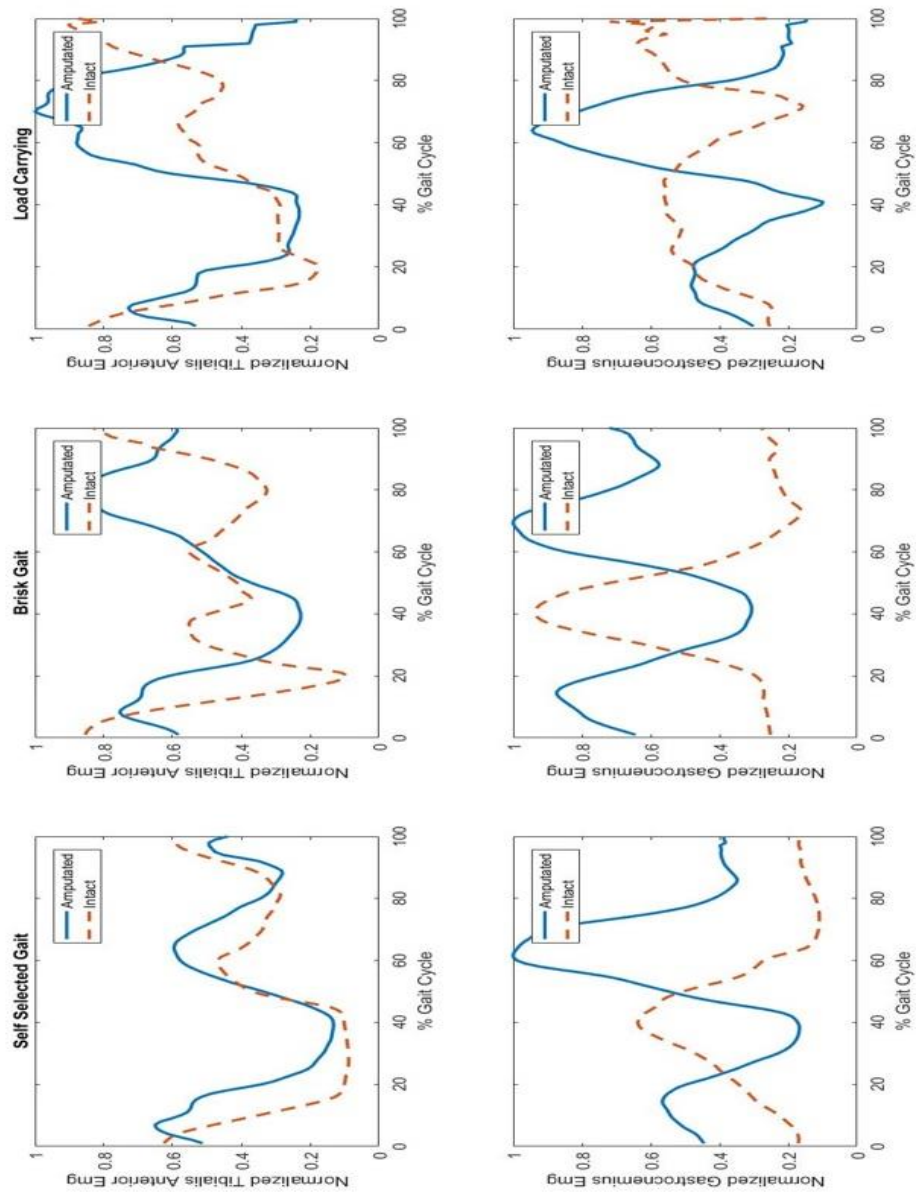

Figure 3.2 Normalized EMG for residual TA, residual GA, Intact TA, and Intact GA for three gait types in a TOA subject.

Further, EMG data indicates that the TA and GA muscles in the residual limb are active at the same time, thus supporting an earlier finding of co-contraction of these muscles as a result of the TOA procedure [18].

The results from the Hypothesis tests are tabulated in Table 3.2 and Table 3.3. The mean values of the minimum and maximum $\overline{E_{RMS}}$ are indicated in the tables along with their standard deviations for all ten TOA subjects used in the hypothesis testing. Since $H = 1$ (Table 3.2), the hypothesis H_1 is rejected in favor of the alternate hypothesis, i.e., $\overline{E_{RMS_{max}}} \neq \overline{E_{RMS_{min}}}$ and it can be concluded that significant activity occurs in the TA muscle in the residual limb. Further, $p < 0.05$ indicates that the alternate hypothesis is accepted with a 95 % confidence interval. Similarly, from Table 3.3, it can be concluded hypothesis H_2 is rejected and it is concluded that significant activity occurs in the GA muscle in the residual limb. Further, $p < 0.05$ indicates that the alternate hypothesis is accepted with a 95 % confidence interval.

GAIT TYPE	$\overline{E_{RMS_{min}}}$	$\overline{E_{RMS_{max}}}$	H	p
Self-Selected (SG)	0.1042 ± 0.0926	0.3431 ± 0.2778	1	0.003578
Brisk (BG)	0.1866 ± 0.1470	0.5329 ± 0.2962	1	0.000161
Load Carrying (LG)	0.1343 ± 0.0640	0.5018 ± 0.3837	1	0.008337

Table 3.2 $\overline{E_{RMS}}$ for Tibialis Anterior in TOA subjects during selected gait activities

GAIT TYPE	$\overline{E_{RMS_{min}}}$	$\overline{E_{RMS_{max}}}$	H	p
Self-Selected (SG)	0.1256 ± 0.1342	0.3413 ± 0.2715	1	0.003038
Brisk (BG)	0.1809 ± 0.1421	0.5823 ± 0.4189	1	0.002975
Load Carrying (LG)	0.1172 ± 0.1355	0.4759 ± 0.3523	1	0.001102

Table 3.3 $\overline{E_{RMS}}$ for Gastrocnemius in TOA subjects during selected gait activities

3.4.2 Residual muscle activation in TTA subjects

The average normalized EMG signals of all four muscle groups in subjects with traditional transtibial amputation are shown in Figure 3.3. The signals were normalized similarly to the approach described for TOA subjects. The results from the Hypothesis tests are tabulated in Table 3.4 and Table 3.5. Unlike TOA subjects, TTA subjects did not show any appreciable activity in the TA muscles in the residual limb for all three gait types considered in this study. While the GA muscles are active, the activation is different from that observed in the GA in the intact limb.

The results from the Hypothesis tests are tabulated in Table 3.4 and Table 3.5. Since $H = 0$ (Table 3.4), hypothesis H3 is accepted over the alternate hypothesis, i.e., $\overline{E_{RMS_{max}}} = \overline{E_{RMS_{min}}}$ and it is concluded that there is no appreciable activity in the TA muscle in the residual limb of a TTA subject. Similarly from Table 3.5, hypothesis H4 is not accepted and it is concluded that significant activity occurs in the GA muscle in the residual limb during self-selected gait and brisk gait. Further, $p < 0.05$ indicates that the alternate hypothesis is accepted with a 95 % confidence interval.

GAIT	$\overline{E_{RMS_{min}}}$	$\overline{E_{RMS_{max}}}$	H	p
Self-Selected (SG)	0.0110 ± 0.0121	0.0570 ± 0.0548	0	0.2081
Brisk (BG)	0.0130 ± 0.0107	0.0868 ± 0.0841	0	0.1552
Load Carrying (LG)	0.0182 ± 0.0184	0.0475 ± 0.0440	0	0.1419

Table 3.4 $\overline{E_{RMS}}$ for Tibialis Anterior in TTA subjects during selected gait activities

GAIT	$\overline{E_{RMS_{min}}}$	$\overline{E_{RMS_{max}}}$	H	p
Self-Selected (SG)	0.0587 ± 0.0569	0.3209 ± 0.0310	1	0.0015
Brisk (BG)	0.1426 ± 0.0966	0.4720 ± 0.2221	1	0.0140
Load carrying (LG)	0.1704 ± 0.0796	0.2590 ± 0.2117	0	0.0615

Table 3.5 $\overline{E_{RMS}}$ for Gastrocnemius in TTA subjects during selected gait activities

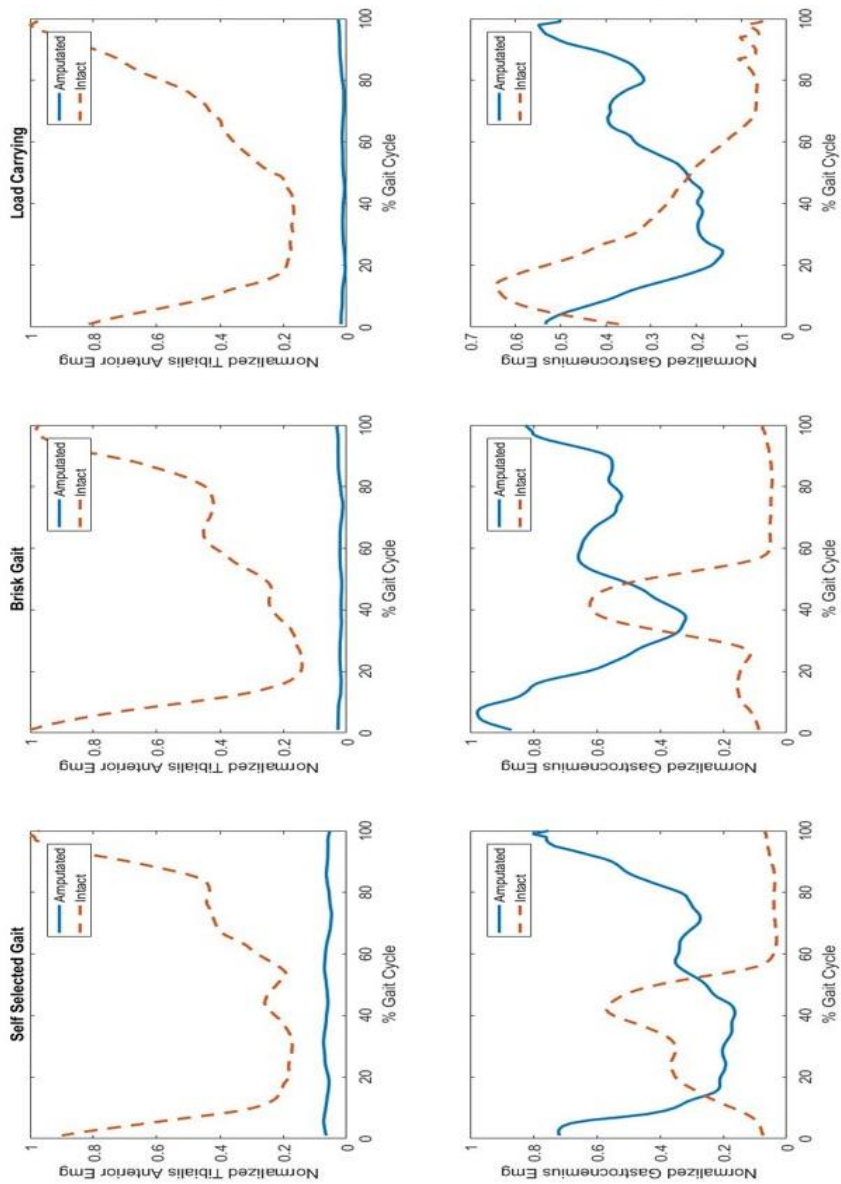

Figure 3.3 Normalized EMG of residual TA, residual GA, Intact TA, and Intact GA for three gait types in a TTA subject

The activity of the residual GA muscle differs considerably in comparison to the GA muscle in the intact limb (Figure 3.1). GA in TTA subjects is more active during the early stance phase and end of swing phase. The authors believe that this discrepancy is due to the fact that the residual muscle no longer retains the same relationship to gait cycle, but rather fires in order to stabilize the residual limb during gait.

3.4.3 Special case

Among the four traditional transtibial amputees, one of the subjects was a “Natural Bridge amputee.” This subject underwent a traditional or traditional transtibial amputation procedure, but over a period of time, the subject’s anatomy adapted itself to form a bony bridge between tibia and fibula resulting in a structure similar to that of the TOA subjects. The muscle activity of the subject is shown in Figure 3.4. It can be clearly seen that there is a substantial muscle activity in the residual TA which is in contrast to the rest of the subjects in the study. The activity pattern of the residual TA and GA muscles is similar to that of TOA subjects with the exception of the magnitude of the activity in the residual TA muscle. The authors hypothesize that this is due to the fact that the bony bridge is providing enough support during gait and thereby altering the effort required of the residual muscles to stabilize the gait. However, further study is required to validate any such conclusions.

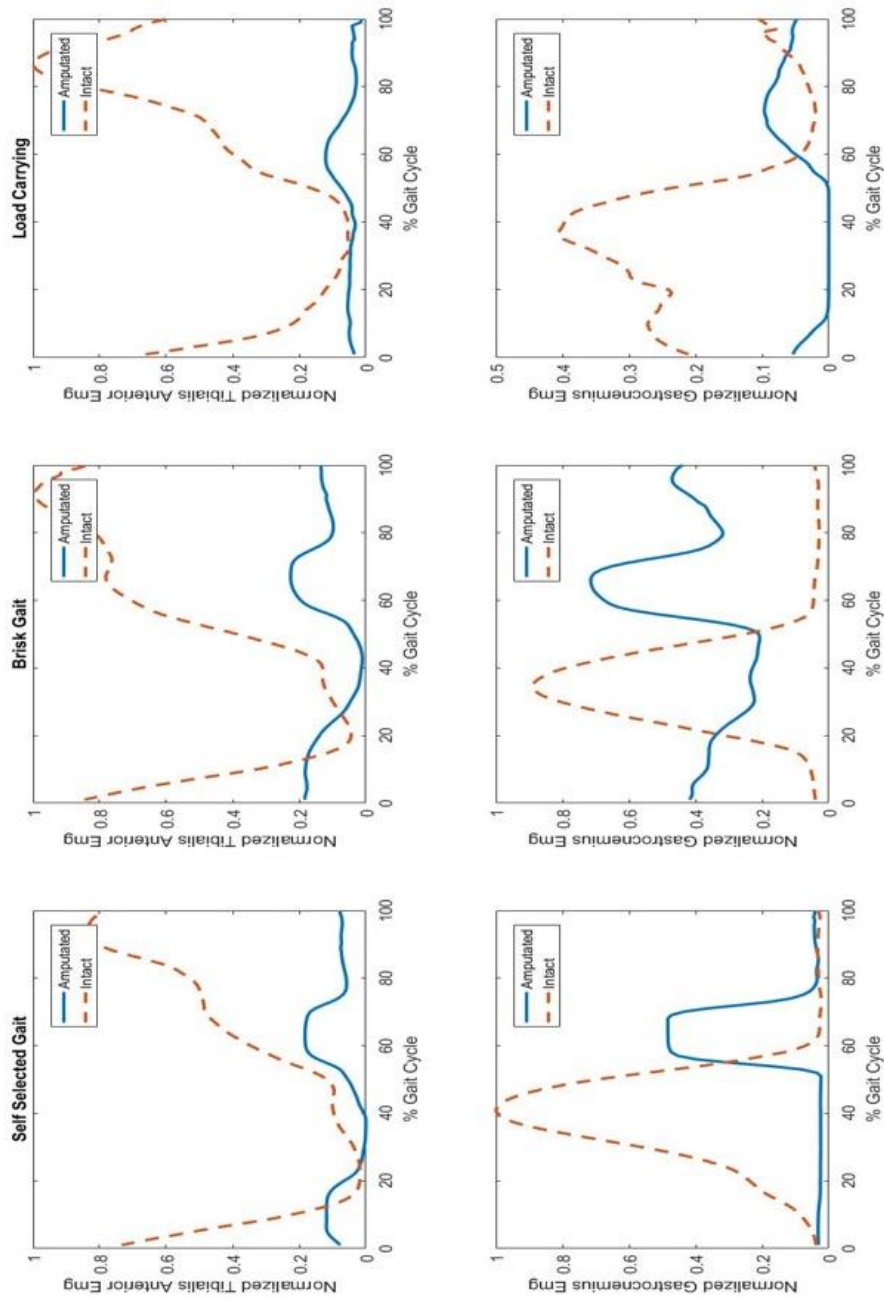

Figure 3.4 Normalized muscle activity in a Natural bridge amputee

3.5 Limitation of the study

This study was limited to healthy, male subjects with unilateral TOA and Traditional transtibial amputation. The dependence of the measured EMG values on gender or others causes was not considered. Furthermore, the study looked at ten subjects with TOA and four subjects with traditional transtibial amputation. A larger set of subjects has to be studied before generalizations can be made. Further, natural bridge amputees also have to be studied in order to ascertain the impact of the residual anatomy on the muscle activities in such subjects.

3.6 Conclusion

This study compared the contraction of residual muscles in subjects with Transtibial Osteomyoplastic Amputation (TOA) and Traditional Transtibial Amputation (TTA) during different gaits encountered during daily activities. Analysis of the data confirmed residual muscle activity in both the muscle groups in all TOA subjects during the three gait activities considered in this study. However, no appreciable muscle activity was recorded in residual Tibialis Anterior of TTA subjects during any of the gaits. While the TA and GA muscles in the residual limb were active during gait, their activation pattern was different from that of intact limb. Similar to results already reported in the literature, co-contraction between the residual tibialis anterior and gastrocnemius muscles was observed in all the TOA subjects. In the case of TTA subjects, no appreciable activity of the residual TA muscles was observed. The residual GA muscle, on the other hand, was active but primarily during the initial stance and late swing phase of the gait. The study also shows that the activity of the muscles in the intact limb is affected by the amputation procedure. It was also observed that changes in the anatomy

of the residual limb can impact the activity of the muscles in the residual limb. The results of this study lay the foundation for understanding the effect of amputation procedure on the muscle activity as well as the health of the residual limb.

Chapter 4: Relationship between Gait Related Activity in Residual and Intact muscles and RSI Force

The relationship between gait related activity in the residual and intact muscles and the forces measured at the residuum-socket interface are of particular interest as they are indicators of muscle health and can provide insight into the effectiveness of gait. This can be particularly useful for the development of smart prosthetic devices that can adapt to variations in gait. Study of RSI forces also allows the prosthetist to evaluate the maximum loading and distribution of forces inside the prosthesis during varied walking tasks instead of just during normal gait. Such information can be used to improve the socket design for end bearing and for improved comfort for the user and thereby positively impact the health of the amputee. The study reported in this Chapter was aimed at addressing these issues in individuals who have undergone TOA procedure.

4.1 Introduction

The TOA procedure is performed on an amputee in order to achieve distal end weight bearing. During this procedure, the residual Tibialis Anterior (TA) and Gastrocnemius (GA) muscles are attached to the bony foundation resulting in the restoration of the length-tension relationship. The activation pattern of these muscles has been reported in previous studies [35]. Similarly, the RSI force at the distal end of the residuum was verified by previous studies [34, 35]. However, the relationship between the residual and intact muscle activation with respect to gait, and the relationship between RSI force and the type of gait has not been studied to the best of our knowledge. This chapter serves two purposes. The first objective is to study the relationship between the muscle activity and type of gait and between RSI force and type of gait. The second objective of the study reported in this chapter is to verify the results regarding the RSI force and

muscle activity found in the previous studies [34, 35]. The muscle contraction profile of an intact muscle is shown in Figure 4.1.

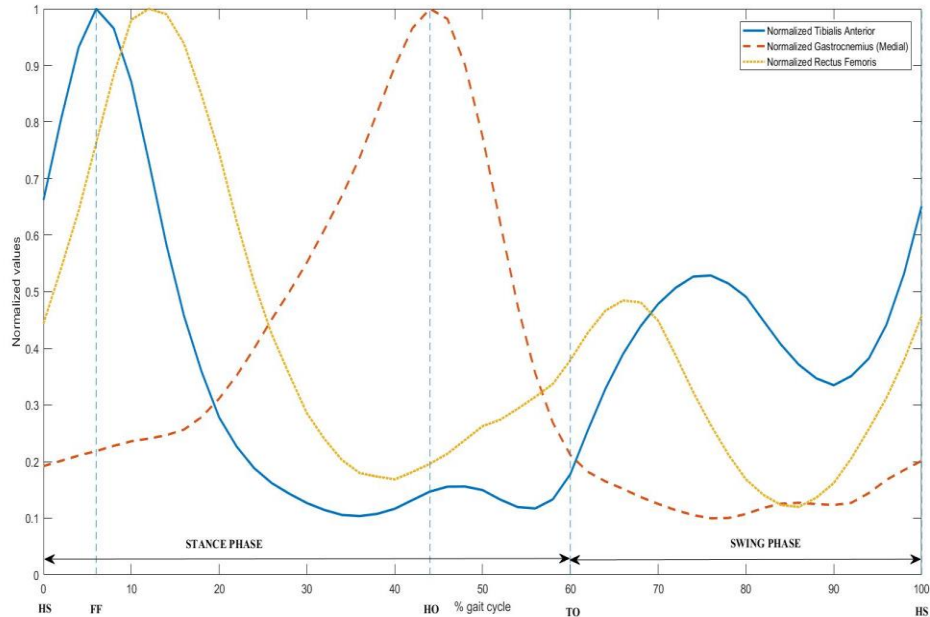

HS - Heel Strike, FF- Foot Flat, HO – Heel Off, TO - Toe Off.

Figure 4.1 Normalized Tibialis Anterior, Gastrocnemius and Rectus Femoris muscle activity in intact individuals (reproduced using data in Table 5.22 and Table 5.24 from the Appendix in Winter [81]).

From Figure 4.1, it can be seen that the Tibialis Anterior (TA) and Rectus Femoris (RF) muscle groups are active during the initial period of the stance phase. The muscles start to activate once again during the beginning of the stance phase and keep increasing into the late stance phase. The TA reached the peak muscle activity during foot flat of the ipsilateral foot during the Loading response period while the RF muscle reaches peak activity after the foot flat during the loading response period of the ipsilateral foot. It can also be observed that the TA and RF muscle activation patterns are quite similar to each other but, the TA muscle activity curve leads the RF curve by a small fraction. The Gastrocnemius (GA) on the other hand is inactive during the beginning of the gait cycle

and the end of the gait cycle and becomes active during the mid- period of the gait cycle. The GA reaches peak activity at the Heel off of the ipsilateral foot during the terminal stance period.

4.2 Objective and Hypothesis

This study aims to infer a relationship between the muscle activity (both intact and residual) and the type of gait undertaken by the amputee. The study also looks at the relationship between the peak distal residuum force and the type of gait. The objective of this study is divided into three parts and corresponding hypothesis to verify these objectives were developed.

Objective 4a: To investigate the relationship between peak muscle activity in the residual limb and gait.

Hypothesis H4a1: Peak muscle activity for residual TA will occur in increasing magnitude during the self-selected walk, brisk walk and weight carry walk.

Hypothesis H4a2: Peak muscle activity for residual GA will occur in increasing magnitude during the self-selected walk, brisk walk and weight carry walk.

Hypothesis H4a3: Peak muscle activity for RF on amputated side will occur in increasing magnitude during the self-selected walk, brisk walk and weight carry walk.

Objective 4b: To investigate the relationship between the peak muscle activity in the intact limb and gait.

Hypothesis H4b1: Peak muscle activity for Intact TA will occur in increasing magnitude during the self-selected walk, brisk walk and weight carry walk.

Hypothesis H4b2: Peak muscle activity for Intact GA will occur in increasing magnitude during the self-selected walk, brisk walk and weight carry walk.

Hypothesis H4b3: Peak muscle activity for Intact RF will occur in increasing magnitude during the self-selected walk, brisk walk and weight carry walk.

Objective 4c: To investigate the relationship between the peak distal force exerted by the residual limb inside the prosthetic socket.

Hypothesis H4c1: Peak distal force will be greater during a brisk walk when compared to self-selected walk.

Hypothesis H4c2: Peak distal force will be greater during weight carry when compared to a brisk walk.

4.3 Methods:

4.3.1. Subjects:

Ten healthy subjects with unilateral Transtibial Osteomyoplastic amputation were chosen for this study. The experimental protocol was approved by the Institutional review board at University of Oklahoma Health Science's Center for the protection of Human subjects. All the subjects used their own prosthesis for the whole duration of the experiment to ensure that the data collected is representative of daily usage of the prosthesis. A certified prosthetist was available on site to ensure the fit and alignment of the Prosthetic socket. Table 4.1 shows the demographics of the subjects that took part in the study.

Subject	Amputation Type	Amputation side	Age (Years)	Height (in)	Weight (lbs)	Length of Residual Limb (cm)
S1	TOA	L	50	72	270	18
S2	TOA	L	32	72	207	17
S3	TOA	R	27	72	200	19.5
S4	TOA	L	30	74	207	24
S5	TOA	L	53	69	160	16
S6	TOA	R	50	71	245	18
S7	TOA	L	38	72	175	16
S8	TOA	R	25	75	215	19
S9	TOA	R	45	67	198	27
S10	TOA	R	28	74	175	12

Table 4.1 Demographics of the subjects L- Left, R- Right

4.3.2. Protocol

Gait: During the period of the experiment the subjects were asked to perform three different walking tasks viz.

Self-Selected gait: Walking at a self-selected pace for the duration of 2 minutes.

Brisk walk: Walking at a fast pace for the duration of 2 minutes.

Weight carry walk: Walking for a distance of 25 feet with while carrying a box with weights filled to capacity.

These walks were chosen among different types of gait as the best representative of the daily activities the subject needs to be able to perform independently. There were onsite Physical Therapists that would make the call on the maximum capacity to be carried by the subject. These calls are made based on the postural changes in the subject while carrying the loaded box.

RSI Force measurement: The residuum socket interface force was measured using the FlexiForce® A201 piezo resistive sensors (Section 2.6). The sensors were placed at the

distal location of the socket at four specific locations viz. anterior, medial, posterior and lateral. Image 4.1 a shows the location of the force sensors inside the prosthetic socket. Placement and calibration of these sensors were discussed in section 2.6. These sensors were used to capture the distal forces and confirm end weight bearing in the TOA amputees.

Electromyography: Muscle activity from the Tibialis anterior, Gastrocnemius and Rectus Femoris muscles from both the residual limb and the intact limb was captured using disposable surface stimulating and recording Ag/AgCl electrodes [75]. A pair of electrodes is placed on the target muscle group as shown in figure 4.1 b as described in section 2.7.

Both the RSI force signals and the EMG signals were captured using the gait monitoring device OUPAM (section 2.5) at a rate of 1 KHz. For the duration of the whole experiment, the subjects also wore an Intelligent Device for Energy Expenditure and Physical Activity (IDEEA®) by MiniSun™ (section 2.5) [62]. The stance and the swing phases of the gait detected using the RSI force measurements was validated by the data captured using the IDEEA® system.

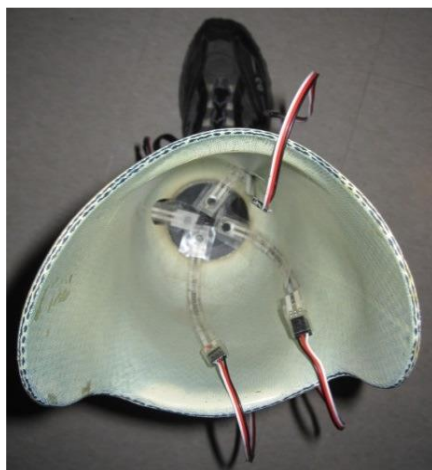

(a)



(b)

Figure 4.2 a) Placement of the distal force sensors inside the prosthetic socket b) Placement of the surface EMG electrodes along the residual TA muscles.

4.3.3 Data Analysis

Distal RSI Force processing: The change in resistance of the force sensors is converted into a voltage by passing it through the circuit shown in figure 2.9 (b). Then it is filtered using a low pass filter of 3Hz to eliminate high-frequency noises. The force sensor readings are substantial only during the stance phase of the gait cycle when the leg is in contact with the ground. During the swing phase, the leg is in the air and the readings from the force sensors are negligible. Thus only the reading during the stance phase is used in this study. 10 representative steps are extracted from all the curves and a mean curve is found out for each sensor. This mean curve is normalized to get 120 data points representing 60% of the gait cycle. The total Distal RSI force was obtained by adding up all the four distal force sensors normalized mean curves i.e. anterior, posterior, lateral and medial. Once the distal force curve was obtained for each type of gait the maximum value of the distal force curve was recorded. This value is the peak distal loading observed during that particular gait.

Electromyography: Each EMG signal from the individual muscles was processed using a linear envelope. The linear envelope consists of a full wave rectifier and a low-pass filter with a cutoff frequency of 8 Hz [70]. A symmetric moving window average of 150 ms wide (± 75 ms) was used to calculate the Root Mean Square curve, E_{RMS} , of the filtered signals. Unlike the force signal the EMG signals show substantial activity in the swing phase of the gait, thus the EMG signal representing the whole gait cycle was used. The E_{RMS} curve was then normalized to 100 data points representing the 100%

gait cycle. The peak values of this E_{RMS} signals for each muscle during each gait was recorded.

Statistical Analysis: For hypothesis H4a1, H4a2, H4a3, H4b1, H4b2, H4b3 will be verified by two two-sample t-tests (one-tailed, paired, $\alpha=0.05$) which look for the significant difference between the two maximum E_{RMS} values from two gaits. The first t-test will be carried out for the forward walk and the brisk- walk and the second will be for the brisk walk and the weight carry walk. Hypothesis H4c1 and H4c2 are verified using two sample t-test (one-tailed, paired, $\alpha=0.05$) which looks for the significant difference between the maximum distal loading between the two gaits.

4.4 Results

4.4.1 The relationship between muscle activity and gait in the amputated limb

Figure 4.2 shows the normalized EMG muscle activity from both the amputated and intact limb. The curves were normalized to the maximum value of all the six sensors for a particular gait. Table 4.2 shows the result of the hypothesis tests H4a1, H4a2, and H4a3.

From the table, it can be inferred that the max E_{RMS} value of all the amputated muscles increased during a brisk walk when compared to the self-selected gait by a significant amount. This is represented by an h-value of 1 for this particular t-test. The p values of all the muscles are <0.05 and thus we can say with 95% confidence that the muscle activity increases from self-selected gait to Brisk gait. This validates part 1 of the hypothesis H4a1, H4a2, H4a3. However, when comparing brisk gait to weight walk gait there was no significant increase in the muscle activity as indicated by the h-value

of 0 for all three muscles. Thus the second part of the hypothesis H4a1, H4a2, H4a3 was not validated.

4.4.2 The relationship between muscle activity and gait in the intact limb

Table 4.3 summarizes the results of Hypothesis tests H4b1, H4b2, H4b3. It can be seen from the table that for the intact limb as well there is an increase in muscle activity from self-selected gait to brisk gait which is represented by an h-value of 1 for all three muscles. The p-value is <0.05 indicating that at 95% confidence interval there is a substantial increase in muscle activity from self-selected gait to Brisk gait. This validates the first part of hypothesis H4b1, H4b2, H4b3. However, in the case of brisk gait to weight carry gait no substantial increase in muscle activity was noted. This is represented by an h-value of 0. Thus, the second part of the hypothesis H4b1, H4b2, H4b3 was not validated.

4.4.3 The relationship between peak distal loading and gait

Figure 4.3 shows the mean distal force inside the residuum socket for all three types of gait. Since substantial force is only observed during the stance period the mean force is plotted for that duration. Table 4.4 summarizes the results of hypothesis tests H4c1 and Table 4.5 summarizes results of hypothesis H4c2 along with Maximum Distal force values for the ten subjects.

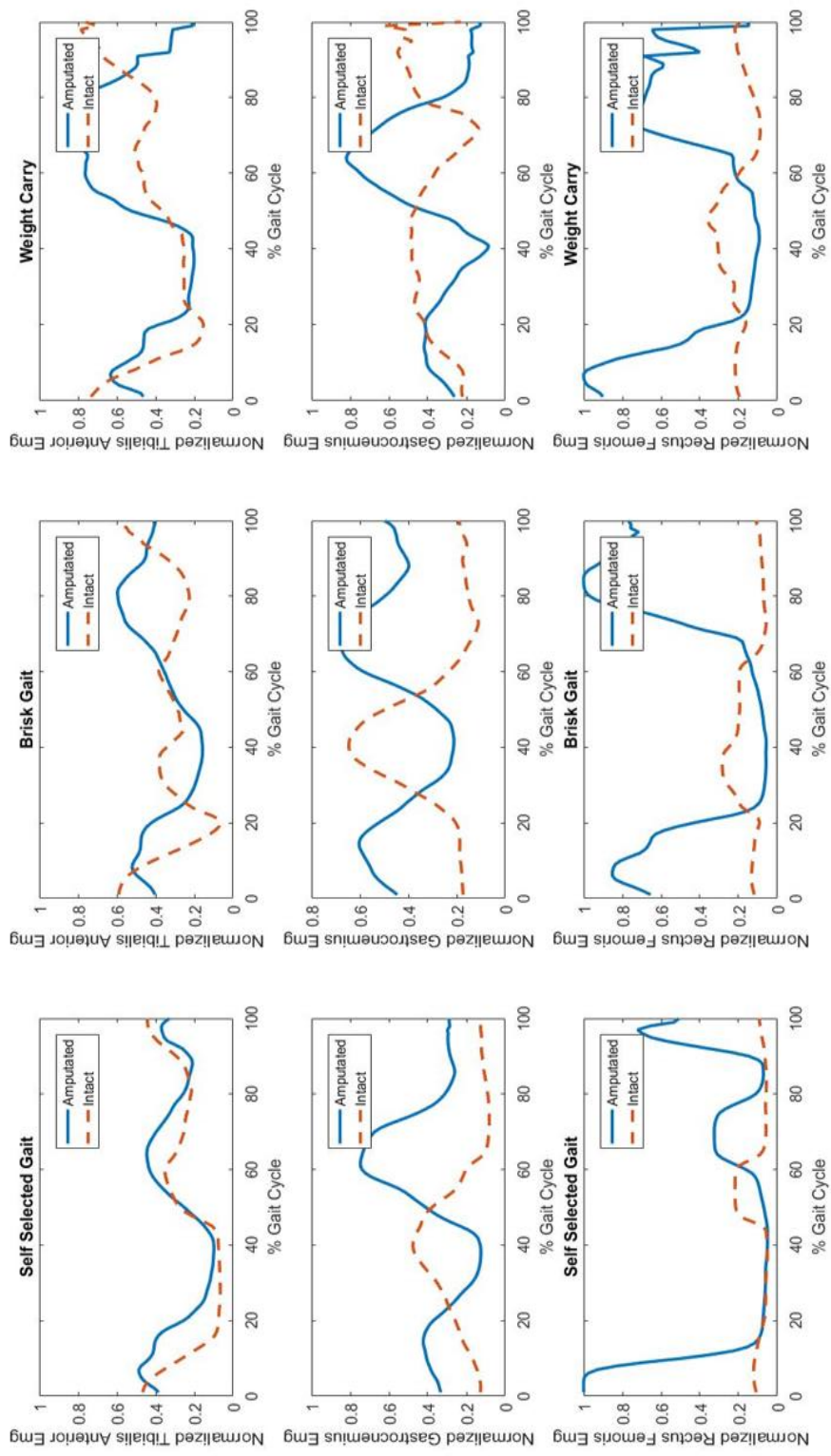

Figure 4.3 Normalized EMG signals for TA, GAS, and RF muscles during all three types of gait

Muscle group	Peak ERMS for Self-Selected walk	Peak ERMS for brisk walk	Peak ERMS for Weight Walk	Self-Selected walk vs brisk walk		Brisk walk vs weight walk	
				h-value	p-value	h-value	p-value
Amputated TA	0.3623±0.3083	0.5540±0.3186	0.5557±0.4290	1	0.000142203	0	0.48874322
Amputated GAS	0.3521±0.2770	0.5875±0.4335	0.4515±0.2648	1	0.014284582	0	0.94025383
Amputated RF	0.3145±0.3252	0.3806±0.3722	0.3277±0.2887	1	0.048285117	0	0.85478136

Table 4.2 Maximum ERMS for TA, GAS and RF muscles of the amputated limb and their relationship to gait

Muscle group	Peak ERMS for forward walk	Peak ERMS for brisk walk	Peak ERMS for Weight Walk	forward walk vs brisk walk		Brisk walk vs weight walk	
				h-value	p-value	h-value	p-value
Intact TA	0.3161±0.1480	0.4716±0.2332	0.3658±0.2444	1	0.002611203	0	0.97648576
Intact GAS	0.3462±0.1299	0.5149±0.1778	0.3293±0.1586	1	0.000127743	0	0.99721676
Intact RF	0.2146±0.2307	0.2598±0.2349	0.1930±0.1588	1	0.001648274	0	0.98002857

Table 4.3 Maximum ERMS for TA, GAS, and RF muscles of the intact limb and their relationship to gait

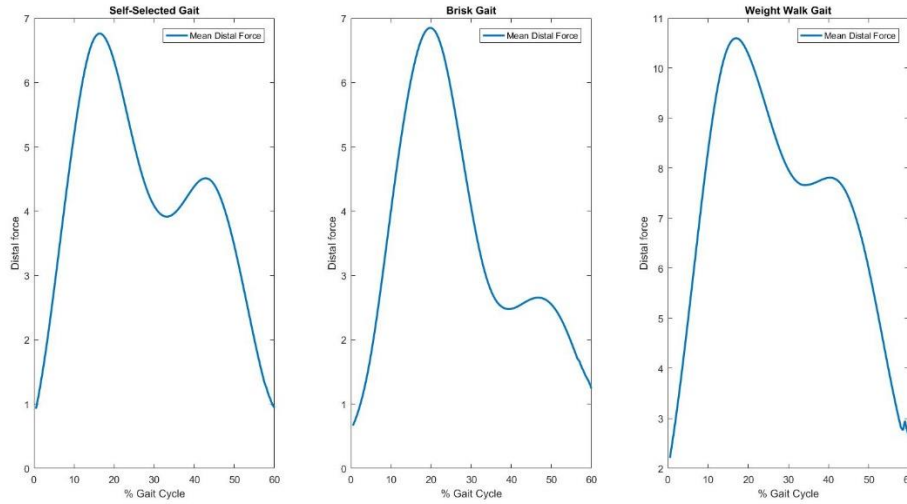

Figure 4.4 Mean distal force for a TOA subject during all three gaits.

Force sensors	Peak Value for Forward Walk	Peak Value for Brisk Walk	h-value	p-value
Distal Force	5.3644±4.2481	5.0118±3.9075	0	0.8541124

Table 4.4 Peak Distal force during Self-Selected and Brisk Gait

From the table 4.4, it can be seen that there is no significant difference between the peak distal force values during the forward walk and brisk walk. Thus hypothesis H4c1 has not been validated. From table 4.5 it can be seen that there is a significant difference between the peak distal force observed during the brisk walk and weight carry walk. This represented by an h-value of 1 and a p-value <0.05. Thus Hypothesis H4c2 has been validated.

Force sensors	Peak Value for Brisk Walk	Peak Value for Weight walk	h-value	p-value
Distal Force	5.0118±3.9075	10.0835±7.20489	1	0.013408

Table 4.5 Peak Distal force during Brisk and Weight Carry gait.

4.5 Discussions

4.5.1 Muscle contraction and activation profiles.

The residual muscle contraction of TA and GA muscles is confirmed and is in agreement with the previous findings [18]. The activation profiles of these muscles are however different from the activation profile of the muscles in the intact limb. The author believes that this is due to the co-contraction of the muscles resulting from the myoplasty procedure. It is interesting to note that the intact RF muscles on the intact limb do not have a similar activation profile as shown in figure 4.1. This is due to the fact that amputees tend to favor their intact limb over their amputated side causing a change in their gait resulting in different activation profile of the RF muscles. In short, it can be explained as the effect of amputation on the activation profile of the intact muscles.

4.5.2 Muscle activation and its relationship with type of gait

From the tables 4.2 and 4.3, it can be inferred that residual and intact muscles, in general, show more muscle activity when the speed of the gait increases. This is in agreement with our prediction as to the relationship between gait and muscle activation. The claim is bolstered with the help of hypothesis tests H4a1 to H4b3 which have been validated for self-selected gait and brisk gait. We also expected to see an increase in muscle activation during the weight carry walk when compared to brisk walk due to the fact that walking with extra weight requires more effort. However, this turned out to be not true as shown in table 4.2 and 4.3. This is supported by the fact that part of hypothesis tests H4a1 to H4b3 for brisk and weight walk was not validated. This might

be due to the change in the step length and height while walking with a box filled with weight.

4.5.3 Peak Distal Force and its relationship to gait

Observation of distal force inside the residuum socket is in agreement with the findings from previous studies and verifies the expected outcome of the TOA procedure. The Peak Distal Force is expected to increase with an increase in the speed of gait.

However, this was not found to be true as shown in Figure 4.3. This is further supported by the fact that Hypothesis test H4c1 was not validated. This may be due to the fact that the difference in speed of walking in amputees is not significantly different as it is in the case of intact subjects. During weight carry walk an increase in distal loading was expected because of the extra weight to be carried during the walk. This was found true as shown in figure 4.3. This is further supported by the fact that hypothesis H4c2 was validated as shown in table 4.5.

4.6 Conclusions

In this chapter, the muscle activation profiles of the residual and intact muscles during work-related activities was studied. Residual TA and GA muscles showed signs of co-contraction and deviation from the standard muscle activation patterns. The RF muscle on the intact limb showed deviation in activation pattern asserting the change in the biomechanics of gait after amputation. Furthermore, analysis to establish a relationship between the muscle activation and peak distal loading with respect to the type of gait was performed. The speed of gait and the magnitude of the muscle activation was found to be directly proportional. However, walking while carrying a weight did not result in an increase in the magnitude of muscle activation as expected. In contrast, Peak distal

loading was found to be independent of the speed of gait and showed a significant increase in magnitude while walking with a weight. Further research into this topic would be beneficial in designing better prosthetic sockets and aid in the rehabilitation of the amputees.

Chapter 5: Conclusions and Scope of Future Work

5.1 Conclusions

Residual muscle health in a below knee amputee is dependent on many factors. Two important factors that heavily influence the health of the residual limb in a healthy individual are the type of amputation and the fit of the prosthetic socket. Improper prosthetic socket fit can lead to musculoskeletal problems such as back pain and skin problems such as irritant contact dermatitis [10], while the type of amputation affects the activity in the residual muscles and the ability to bear weight at the end of the residual limb. The presence of muscle activity during gait prevents atrophy of muscles due to inactivity and end weight bearing allows an amputee to better balance their weight during gait preventing overloading of the intact limb. Thus, in this thesis, effects of the type of amputation on the residual muscle activity and the correlation of RSI force and muscle activity to gait are studied.

TOA procedure is known to provide distal end weight bearing and restore the length tension relationship in the residual muscles. Previous studies have looked at verifying the outcomes of the TOA procedure [17, 18]. However, a comparative study between outcomes of TOA procedure and TTA procedure has never been investigated. In this thesis, a comparative study between the residual muscle activation in TOA and TTA subjects has been undertaken. It has been shown that in the case of TOA subjects there is considerable muscle activity in both the muscle groups (Tibialis Anterior and Gastrocnemius). Furthermore, even though the muscles were active during gait, the activation pattern differed from the standard activation pattern of an intact muscle indicating the effect of amputation on muscle activation. The activation pattern of the

residual muscles for TOA subjects was in agreement with the previous findings. In the case of TTA subjects, the residual Tibialis Anterior muscle was shown to be inactive during all three gaits while the residual Gastrocnemius was active during all the three gait activities. The research findings in this thesis have led to the coining of a new term ‘Natural Bridge amputee’ wherein the amputated limb of the subject with TTA amputation adapted to form a natural bone bridge between the tibia and the fibula bones. The muscle activation pattern from this subject deviated from the rest of the TTA amputees indicating that changes in the anatomy of the subject have an impact on the muscle activity.

In the literature, muscle activity during different gait was investigated by several researchers. However, the correlation between gait and muscle activity in TOA subjects was never determined. By establishing a correlation between muscle activity and RSI force to gait, one can predict the gait intent of the amputee and help in developing better prosthesis that can help improve the health of the amputee. In this thesis, effort has been made to study the correlation between gait and the two parameters that affect residual limb health.

It has been shown that the residual muscle activity is positively correlated to the speed of gait, while no direct correlation between speed of gait and RSI force was found. However, RSI force was positively correlated with the weight of the upper body this was shown with an increase in peak distal force during the weight carry walk.

5.2 Limitations and Scope of Future work

Both the studies in this thesis were limited to healthy men with unilateral transtibial amputation. Thus these studies need to be extended to include healthy, working age

women in order to extend the results to a larger population. Further research needs to be carried out to include people with diabetes and other disorders in order to study the effects of the disorder on the gait performance of the amputees. The results of the studies reported in Chapters 3 and 4 are based on data from a small group of test subjects. While the results clearly demonstrated the benefits of the TOA procedure, research involving a larger population pool is necessary before any generalization can be made.

Previous studies have validated the expected outcomes of the TOA amputation. However, the changes in the residual muscle activity and RSI force over time has not been addressed. Thus, future research along these lines can help assess whether residual muscle activity and RSI force can be used as a reliable source of control signals for controlling active prosthetic devices. The results reported in this thesis can also help assess the changes in the prosthetic socket fit over time and thereby provide data to the prosthetist for making modifications to the socket. Timely assessment of prosthetic socket can help avoid back pain and chronic skin problems in amputees.

References

- 1) K. Ziegler-Graham, E. J. MacKenzie, P. L. Ephraim, T. G. Travison, and R. Brookmeyer, "Estimating the prevalence of limb loss in the United States: 2005 to 2050," *Arch Phys Med Rehabil*, vol. 89, no.3, pp. 422-429, 2008.
- 2) Owings, M F, and L J Kozak. "Ambulatory and Inpatient Procedures in the United States, 1996." *Vital and Health Statistics. Series 13, Data from the National Health Survey*, no. 139, 1998, pp. 1-119.
- 3) Douglas G. Smith. "Transtibial Amputation Successes and Challenges." Available at www.amputee-coalition.org/wp-content/uploads/2015/04/meddir-1.pdf
- 4) Chad A. Kruger, Joseph C. Wenke, James R. Ficke. (2012). "Ten Years at war: Comprehensive analysis of amputation trends." *Journal of Trauma*, vol.73, no.6, 2012.
- 5) H. Bateni and S. J. Olney. "Kinematic and kinetic variations of below-knee amputee gait." *Journal of Prosthetics and Orthotics*, vol.14, pp. 2-13, 2002.
- 6) I. Kovac, V. Medved, and L. Ostojic, "Spatial, temporal and kinematic characteristics of traumatic transtibial amputee's gait," *Collegium Antropologicum*, vol. 34, pp. 205-213, 2010.
- 7) N. P. Fey, A. K. Silverman, and R. R. Neptune, "The influence of increasing steady-state walking speed on muscle activity in below-knee amputees," *Journals of Electromyography and Kinesiology*, vol. 20, pp. 155-161, 2010.
- 8) L.F. Yeung, A.K. Leung, M. Zhang, W.C. Lee, "Long-distance walking effects on trans-tibial amputees compensatory gait patterns and implications on prosthetic designs and training." *Gait Posture*, vol. 35, pp. 328-333, 2012.
- 9) Gailey. R, et al. "Review of secondary physical conditions associated with lower-limb amputation and long-term prosthesis use." *Journal of Rehabilitation Research & Development*, vol.45, no.1, pp.15-29, 2008.
- 10) J. T. Highsmith and M. J. Highsmith. "Common skin pathology in LE prosthesis users." *Journal of the American Academy of Physician Assistants*, vol.20, no.11, pp. 33-36, 2007.
- 11) T. R. Dillingham, L. Pezzin, E. MacKenzie, and A. R. Burgess, "Use and satisfaction with prosthetic devices among persons with trauma-related amputations: a long-term outcome study," *Am J Phys Med Rehabil*, vol. 80, no.8, pp. 563-571, 2001.
- 12) Y.-L. Chou, S.-S. Shi, G.-F. Huang, and T.-S. Lin, "Interface pressure and gait analysis in different walking speeds and on the below-knee amputees with

- multiple axis prosthetic foot prosthesis," *Biomedical Engineering – Applications Basis Communications*, vol. 15, pp. 207-211, 2003.
- 13) S. A. Gard, "Use of quantitative gait analysis for the evaluation of prosthetic walking performance," *Journal of Prosthetics and Orthotics*, vol. 18, pp. 93-103, 2006.
 - 14) M. J. Hsu, D. H. Nielsen, S. J. Lin-Chan, and D. Shurr, "The effects of prosthetic foot design on physiologic measurements, self-selected walking velocity, and physical activity in people with transtibial amputation," *Arch Phys Med Rehabil*, vol. 87, pp. 123-129, Jan 2006.
 - 15) H. Bateni and S. J. Olney, "Kinematic and kinetic variations of below-knee amputee gait," *Journal of Prosthetics and Orthotics*, vol. 14, pp. 2-13, 2002.
 - 15) Össur. (2015). Proprio Foot. Available at: <http://www.ossur.com/?PageID=12704>
 - 16) empower. (2017). BIONX – Inspired by you. Available at: <http://try-empower.com/>
 - 17) S. Commuri, J. Day, C. Dionne, and W. Ertl, "Assessment of pressures within the prosthetic socket of a person with osteomyoplastic amputation during varied walking tasks," *Journal of Prosthetics and Orthotics*, vol. 22, pp. 127-137, 2010.
 - 18) Anh Mai, et. all. "Residual Muscle Contraction and Residuum Socket Interface Force in Men with Transtibial Osteomyoplastic Amputation." *Journal of Prosthetics and Orthotics*. vol.25, no. 3, pp. 151-159.
 - 19) Loon HE: Below-knee amputation surgery. *Artif Limbs*. vol.6, pp. 86-99, 1961.
 - 20) Kuiken T. "Targeted reinnervation for improved prosthetic function." *Phys Med Rehabil Clin N Am*. vol.17, no.1, pp. 1-13, 2006.
 - 21) Janos P Ertl, et all. "Lower Extremity amputations." *Medscape*. Available at: <http://emedicine.medscape.com/article/1232102-overview#a11>
 - 22) John H. Bowker, Bertram Goldberg, Pradip D. Poonekar. "Atlas of Limb Prosthetics: Surgical, Prosthetic, and Rehabilitation Principles. Chapter 18A."
 - 23) J. Ertl, "Prosthetic primer: Pain and the inactive residual extremity syndrome," *inMotion*, vol. 10, Oct, 2000.
 - 24) J. W. Ertl, J. P. Ertl, W. J. Ertl, and J. Stokosa. "The Ertl osteomyoplastic transtibial amputation reconstruction." 2015. Available: <http://www.ertlreconstruction.com/2015/06/the-ertl-osteomyoplastic-transtibial-amputation-reconstruction/>

- 25) B. C. Taylor and A. Poka, "Osteomyoplastic transtibial amputation: technique and tips," *Journal of Orthopaedic Surgery and Research*, vol. 6, pp. 1-4, 2011.
- 26) C.P.Dionne et.al. "Cross-Sectional Study of Residuum Measures during Gait and Work-Related Activities in men with Transtibial Amputation Resulting from a Traumatic Event." *Journal of Prosthetics and Orthotics*. vol.26, pp.128-133, 2014.
- 27) Anh Mai, Sesh Commuri et.al. "Residual Muscle Contraction and Prosthetic Socket Interface Force in a Transtibial Amputee upon the Osteomyoplastic Procedure – A Preliminary study." *Biosignals and Biorobotics Conference (BRC)*, pp. 1-6, 2012.
- 28) R. Versluys, P. Beyl, M. V. Damme, A. Desomer, R. V. Ham, and D. Lefeber, "Prosthetic feet: state-of-the-art review and the important of mimicking human ankle-foot biomechanics," *Disability and Rehabilitation: Assistive Technology*, vol. 4, pp. 65-75, 2009.
- 29) Prosthetic feet (2017). Available at: <http://www.pandocare.com/prosthetic-feet/>
- 30) J.-M. Casillas, V. Dulieu, M. Cohen, I. Marcer, and J.-P. Didier, "Bioenergetic comparison of a new energy-storing foot and SACH foot in traumatic belowknee vascular amputations," *Archives of Physical Medicine and Rehabilitation*, vol. 76, pp. 39-44, 1995.
- 31) D. H. Nielsen, D. G. Shurr, J. C. Golden, and K. Meier, "Comparison of energy cost and gait efficiency during ambulation in below-knee amputees using 153 different prosthetic feet - A preliminary report," *Journal of Prosthetics and Orthotics*, vol. 1, pp. 24-29, 1989.
- 32) L. Torburn, J. Perry, E. Ayyappa, and S. L. Shanfield, "Below-knee amputee gait with dynamic elastic response prosthetic feet: A pilot study," *Journal of Rehabilitation Research and Development*, vol. 27, pp. 369-384, 1990.
- 33) K. Postema, H. J. Hermens, J. de Vries, H. F. Koopman, and W. H. Eisma, "Energy storage and release of prosthetic feet. Part 1: Biomechanical analysis related to user benefits," *Prosthetics and Orthotics International*, vol. 21, pp. 17-27, 1997.
- 34) S. K. Au, J. Weber, and H. Herr, "Powered ankle-foot prosthesis improves walking metabolic economy," *IEEE Transactions on Robotics*, vol. 25, pp. 51-66, 2009.
- 35) Ossur Variflex XC rotate. available at: <https://www.ossur.com/prosthetic-solutions/products/all-products/feet/vari-flex-xc-rotate> accessed : 03/29/2017.

- 36) S. I. Wolf, M. Alimusaj, L. Fradet, J. Stegel, and F. Braatz, "Pressure characteristic at the stump/socket interface in transtibial amputees using an adaptive prosthetic foot," *Clinical Biomechanics*, vol. 24, pp. 860-865, 2009.
- 37) A. M. Grabowski and S. D'Andrea, "Effects of a powered ankle-foot prosthesis on kinetic loading of the unaffected leg during level-ground walking," *Journal of Neuro Engineering and Rehabilitation*, vol. 10, pp. 1-12, 2013.
- 38) J. Hitt, T. Sugar, M. Holgate, R. Bellman, and K. Hollander, "Robotic transtibial prosthesis with biomechanical energy regeneration," *International Journal of Industrial Robot*, vol. 36, pp. 441-447, 2009.
- 39) R. Versluys, A. Desomer, G. Lenaerts, M. V. Damme, P. Beyl, G. V. d. Perre, L. Peeraer, and D. Lefeber, "A pneumatically powered below-knee prosthesis: design specifications and first experiments with an amputee," in *2nd Biennial IEEE/RAS-EMBS International Conference on Biomedical Robotics and Biomechanics*, Scottsdale, AZ, USA, 2008, pp. 372-377.
- 40) Fillauer Raize (2017). Available at: <http://fillauer.com/Lower-Extremity-Prosthetics/feet/raize.html>
- 41) Anh Mai et.al, "Effect of Prosthetic foot on residuum-socket Interface Pressure and Gait Characteristics in an Otherwise Healthy Man with Transtibial Osteomyoplastic Amputation." *Journal of Prosthetics and Orthotics*, vol. 24, no.4, pp. 211-222, 2014.
- 42) Lower Body Muscle Anatomy Back Of Leg Muscles Human Anatomy Diagram. Available at: <http://human-anatomy101.com/lower-body-muscle-anatomy/lower-body-muscle-anatomy-back-of-leg-muscles-human-anatomy-diagram/>
- 43) Daniel E. Lieberman. "Human locomotion and heat loss: an evolutionary perspective." *Comprehensive Physiology*, vol. 5, pp. 99-117, 2015.
- 44) Physical examination: gait (2017). Available at: <http://epomedicine.com/clinical-medicine/physical-examination-gait/>
- 45) J. Perry, *Gait Analysis: Normal and Pathological Function*, 1 ed. *Thorofare, NJ: SLACK Incorporated*, 1992.
- 46) R. A. Cooper, L. A. Quatrano, S. J. Stanhope et al. "Gait analysis in rehabilitation medicine: a brief report." *American Journal of Physical Medicine and Rehabilitation*, vol. 78, no.2, pp. 278-280, 1999.
- 47) M. Saleh and G. Murdoch. "In defence of gait analysis. Observation and measurement in gait assessment." *Journal of Bone and Joint Surgery*, vol. 67, no.2, pp. 237-241, 1985.

- 48) R. D. Snyder, C. M. Powers, C. Fontaine, and J. Perry. "The effect of five prosthetic feet on the gait and loading of the sound limb in dysvascular below-knee amputees." *Journal of Rehabilitation Research and Development*, vol.32, pp. 309-315, 1995.
- 49) P. A. Macfarlane, D. H. Nielsen, D. G. Shurr et al. "Transfemoral amputee physiological requirements: comparisons between SACH foot walking and Flex-foot walking." *Journal of Prosthetics and Orthotics*, vol. 9, pp. 138-143, 1997.
- 50) E. G. Gonzalez, P. J. Corcoran, and R. L. Reyes. "Energy expenditure in below-knee amputees: correlation with stump length." *Archives of Physical Medicine and Rehabilitation*, vol. 55, pp. 111-119, 1974.
- 51) A. H. Hansen, D. S. Childress, S. C. Miff, S. A. Gard, and K. P. Mesplay, "The human ankle during walking: Implications for design of biomimetic ankle prostheses," *Journal of Biomechanics*, vol. 37, pp. 1467-1474, 2004.
- 52) K. R. Archer, R. C. Castillo, E. J. Mackenzie, and M. J. Bosse, "Gait symmetry and walking speed analysis following lower-extremity trauma," *Phys Ther*, vol. 86, pp. 1630-1640, 2006.
- 53) A. S. Soares, E. Y. Yamaguti, L. Mochizuki, A. C. Amadio, and J. C. Serrao, "Biomechanical parameters of gait among transtibial amputees: a review," *Sao Paulo Med J*, vol. 127, pp. 302-309, 2009.
- 54) Ossur®. Available: <http://www.ossur.com/> (Accessed on 03/30/2017)
- 55) Orthocare Innovations™. Available: <http://www.orthocareinnovations.com/> (Accessed on 03/30/2017)
- 56) A. L. Schmidt, M. L. Pennypacker, A. H. Thrush et al. "Validity of the StepWatch Step Activity Monitor: Preliminary Findings for Use in Persons with Parkinson Disease and Multiple Sclerosis." *Journal of Geriatric Physical Therapy*, vol.34, no. 1, pp. 41-45, 2011.
- 57) M. G. Bowden and A. L. Behrman. "Step Activity Monitor: Accuracy and test-retest reliability in persons with incomplete spinal cord injury." *Journal of rehabilitation Research and Development*, vol. 44, no. 3, pp. 355-362, 2007.
- 58) J. M. Stepien, S. Cavenett, L. Taylor, M. Crotty. "Activity Levels Among Lower-Limb Amputees: Self-Report Versus Step Activity Monitor." *Archives of Physical Medicine and Rehabilitation*, vol. 88, no. 7, pp. 896-900, 2007.
- 59) N. L. Dudek, O. D. Khan, E. D. Lemaire et al. "Ambulation monitoring of transtibial amputation subjects with patient activity monitor versus pedometer." *Journal of rehabilitation Research and Development*, vol. 45, no. 4, pp. 577-586, 2008.

- 60) StepWatch Activity Monitor (SAM) from Orthocare Innovations™. Available: <http://orthocareinnovations.com/stepwatch/> (Accessed on 03/30/2017)
- 61) Smart Pyramid from Orthocare Innovations™. Available: <http://orthocareinnovations.com/smart-pyramid/> (Accessed on 03/30/2017)
- 62) MiniSun. (2015). Intelligent device for energy expenditure and activity (IDEEA). Available: http://www.minisun.com/IDEEA_Overview.asp
- 63) Anh Mai, "Gait Performance and control of a prosthetic ankle joint for below-knee amputees," Doctor of Philosophy, School of Electrical and Computer Engineering, University of Oklahoma, Norman, OK, 2015.
- 64) S. H. K. R. Gadigota, "Development of a prosthetic activity monitor for gait detection and classification in transtibial amputees," Master of Science, School of Electrical and Computer Engineering, University of Oklahoma, Norman, OK, 2011.
- 65) Atmel. (2015). Microcontrollers. Available: <http://www.atmel.com>
- 66) Jia X, Zhang M, Lee WCC. "Load Transfer mechanics between transtibial prosthetic socket and residual limb-dynamic effects." *Journal of Biomech*, vol. 37, pp. 13711-1377, 2004.
- 67) Tekscan. (2015). FlexiForce sensors - User manual. Available: <http://www.tekscan.com/pdf/A201-force-sensor.pdf>
- 68) Bogey R A, Perry J, Bontrager E L, Gronley J K. "Comparison of across-subject EMG profiles using surface and multiple indwelling wire electrodes during gait." *Journal of Electromyography and Kinesiology*, vol. 10, pp. 255-259, 2000.
- 69) Portnoy S, Siev-Ner I, Kristal A, et al. "Surgical and morphological factors that affect internal mechanical loads in soft tissues of the transtibial residuum." *Ann Biomech Eng*, vol. 37, no. 12, pp. 2583-2605, 2009.
- 70) D. A. Winter, "Biomechanics and motor control of human movement", 4 ed. *Hoboken, N.J.: Wiley*, 2009.
- 71) J. D. Miller, M. S. Beazer, and M. E. Hahn, "Myoelectric walking mode classification for transtibial amputees," *IEEE Transaction on biomedical engineering*, vol. 60, pp. 2745-2750, 2013.
- 72) B. Silver-Thorn, C. T, and B. Kuhse, "Preliminary investigation of residual limb plantarflexion and dorsiflexion muscle activity during treadmill walking for trans-tibial amputees," *Prosthetics and Orthotics International*, vol. 36, pp. 435-442, 2012.

- 73) S. Huang and D. P. Ferris, "Muscle activation patterns during walking from transtibial amputees recorded within the residual limb-prosthetic interface," *Journal of NeuroEngineering and Rehabilitation*, vol. 9, pp. 1-16, 2012.
- 74) M. Seyedali, J. M. Czerniecki, D. C. Morgenroth, and M. E. Hahn, "Cocontraction patterns of trans-tibial amputee ankle and knee musculature during gait," *Journal of NeuroEngineering and Rehabilitation*, vol. 9, pp. 1-9, 2012.
- 75) TheElectrodeStore. (2015). Disposable surface electrodes. Available: <http://www.electrodestore.com/emg/emg-surface-electrodes/disposable-surfaceelectrodes>
- 76) H. J. Hermens, B. Freriks, C. Disselhorst-Klug, and G. Rau, "Development of recommendations for SEMG sensors and sensor placement procedures," *Journal of Electromyography and Kinesiology*, vol. 10, pp. 361-374, 2000.
- 77) M. B. I. Reaz, M. S. Hussain, and F. Mohd-Yasin, "Techniques of EMG signal analysis: detection, processing, classification and applications," *Biological Procedures Online*, vol. 8, pp. 11-35, 2006.
- 78) C. P. Dionne, "Work Task Performance in Amputees with Trans-Tibial Amputation Due to a Traumatic Event (TTAT)," IRB Number: 15948, 2011.
- 79) C. P. Dionne, "Residual Limb Measures During Biomechanical Work-Related Activities in Adult Oklahomans with Unilateral-Trans-Tibial Amputation due to a Traumatic Event," IRB Number: 15713, 2011.
- 80) Deffer PA: Ertl osteoplasty at Valley Forge General Hospital. *Amputee Clinics Newsletter* vol.1, no.1, pp.1, 1969.
- 81) Winter DA. "The Biomechanics and Motor control of Human Gait: Normal, Elderly, and Pathological." 2nd Ed. Waterloo, Ontario, Canada: University of Waterloo, Press; 1991.
- 82) Kirtley C. "Clinical Gait Analysis – Theory and Practice." London: Churchill Livingstone; pp.149-150, 2006.
- 83) Culham EG, Peat M, Newell E. "Below knee amputation: a comparison of the effect of the SACH foot and single axis foot on electromyography patterns during locomotion." *Prosthet Ortho Int*, vol.10, no.1, pp.15-22, 1986.
- 84) Matlab [computer program].Release 2016a. Natick, MA: MathWorks Inc, 1984.
- 85) Schrock RD, Zetl JH, Burgess EM, Romano RL. "A preprimary report of basic studies from prosthetics research study." *Bull Prosthet Res*. pp. 90-105, 1968.

- 86) Burgess EM, Moore AJ. "A study of interface pressures in the below-knee prosthesis (physiological suspension: an interim report)." *Bull Prosthet Res.* pp. 58-70, 1977.