

INSTRUCTIONAL AIDS
IN
PRE-VOCATIONAL MECHANICAL DRAWING

SEP 27 1938

INSTRUCTIONAL AIDS
IN
PRE-VOCATIONAL MECHANICAL DRAWING

By

Robert Marvin Earley

"

Bachelor of Science
Kansas State Teachers' College
Pittsburg, Kansas

1932

Submitted to the Department of
Trade and Industrial Education
Oklahoma Agricultural and Mechanical College
In Partial Fulfillment of the Requirements
For The Degree

Of

MASTER OF SCIENCE

1938

LIBRARY
AGRICULTURAL MECHANICAL COLLEGE
PITTSBURG, OKLA.

Approved:

N. A. Huntington

In Charge of Thesis

N. A. Huntington

Head of the Department of Trade and
Industrial Education

W. C. M. Ingham

Dean of the Graduate School

PREFACE

For the past several years, the writer, while teaching beginning classes in mechanical drawing, has noted the apparent difficulty pupils have in mastering the fundamentals used by draftsmen in their every day work. Among these difficulties, the inability of the pupil to understand clearly the importance of words and terms seems to be the greatest. This is perhaps due to the fact that many of the text books do not make any attempt to define clearly the terms that are used in connection with the drawings to be made. These terms must be simplified and a concrete example of each should be given in order that the beginning pupil can grasp the full meaning of each term in a limited time.

It is also true that the beginning pupil, whether in the junior high school or the senior high school, is unable to pronounce and spell correctly the new words and terms and that his knowledge of them increases slowly without special emphasis upon them. The reason for this condition existing, as the writer sees it, is because spelling as such ceased to be an important subject in his field of study when the pupil left the grade school. The logical way to overcome this difficulty is to devote a part of the class time to spelling lessons. A list of such words and terms should be placed before the pupil. They should be correctly pronounced and explained before the pupil is asked to study them.

There seems to be a decided lack of ability on the part of the pupil to apply simple arithmetic to drawing problems. There has been a great deal of oral and written criticism of mathematics texts and

methods used in the teaching of mathematics, however, it is not the intention of the writer to criticize mathematic instructors or the authors of text books now in use. If this condition exists the instructor of mechanical drawing has a fine opportunity to teach the pupil a few practical uses of the mathematics he has learned. In some cases the failure to apply mathematics properly can be found in the pupil's weakness in making close observations and in self reliance.

Generally speaking drawing instructors as a group find the beginning pupil a problem when placed in a mixed class. Many instructors have classes in which there is a wide range of activity. It is common to find first year, second year, and third year pupils in one class. To make the situation more complicated a part of this group may be working on architectural drawing, another part on machine drawing, another on orthographic projection, another on revolutions, etc. In such situations instructors find it difficult to budget their time so they can properly care for the needs of all and under such conditions the beginner creates the greatest problem.

In studying this situation to find a remedy, the writer has experimented with the plan of using prepared charts for the purpose of establishing a more satisfactory system of giving instruction, lectures, and tests. These instructional aids, when designed for drawing room use have been drawn on white five-ply mat board which measures 28 inches by 44 inches. All of the drawings were made with speedball pens and black waterproof drawing ink.

The speedball pens were used in the following manner: For all heavy lines such as border lines, outline of parts, cutting plane lines, short break lines, and lettering, the B-O speedball pen was

used.

By using the pens as prescribed above all charts are plainly visible for class room work.

In the February, 1937 issue of the Industrial Arts And Vocational Education Magazine, Page 62, Mr. R. R. Bedker of Wauwatosa, Wisconsin suggests the use of "Flash Cards" as a successful aid in the presentation of mechanical drawing. After checking catalogs from the Manual Arts Press and the Bruce Publishing Company, and the various issues of the last four years of the Industrial Arts And Vocational Education Magazine and the Industrial Education Magazine the writer is led to believe there are no charts of this type available on the present day market.

It is the writer's idea, therefore, to make a compilation of some few problems which can be used to teach and test the fundamentals used in beginning mechanical drawing. Such compilation is, of necessity, a long task and one which will never really be completed. More work should be done to carry on the preparation of such instructional units. The writer hopes his small contribution may aid in the development of this study.

The writer wishes to acknowledge his grateful appreciation of the help and guidance extended him by Prof. H. A. Huntington, head of the department of Trade and Industrial Education, to the Library Staff of Oklahoma Agricultural and Mechanical College and the instructors of mechanical drawing who have been so very kind and gracious in both criticising and validating these instructional aids.

TABLE OF CONTENTS

Preface - - - - -	iii
I - Introduction - - - - -	1
II - Spelling - - - - -	4
III - Lettering - - - - -	8
IV - Lines and Line Work - - - - -	15
V - Testing Pupils' Ability To Read The Scale -	20
VI - Testing Your Ability To Judge Angles - - -	25
VII - Essay Test in Finding Errors in Drawing -	32
VIII - Testing Your Ability to Choose the Proper Line for the Proper Place - - - - -	38
IX - Testing Your Ability to Determine Correct Dimensions - - - - -	45
X - Testing Your Ability to Choose and Properly Locate Views in Orthographic Projection - -	51
XI - Freehand Sketching - - - - -	62
XII - Conclusion - - - - -	67
BIBLIOGRAPHY - - - - -	69

CHAPTER I

INTRODUCTION

Today in the teaching of mechanical drawing there is available a wide variety of text books, especially for the first course offered. By making a close observation of these text books one may readily note a slight disagreement among the authors as to terminology, conventions, and methods.

In the February, 1937 issue of the "Industrial Arts and Vocational Education Magazine," Mr. Victor A. Johnson in his article on, "Teaching Devices in Mechanical Drawing" makes the following statement:

"As the industrial arts instructor extends his knowledge of what and how to teach, he is forced to the conclusion that past and present practices are as varied as the number of teachers. The field of mechanical drawing is not unique in this respect. Very few attempts have been made to establish the superiority of any given method or procedure."

This condition will continue to exist until a more exacting set of standards are established in the field of mechanical drawing and that time is at hand.

Randolph Philip Hoelscher in his book "The Teaching of Mechanical Drawing" gives a clear picture of present day progress as follows:

"At the present time teachers are somewhat handicapped in their teaching of good technique, because there is no standard system of conventions that is recognized throughout the country as authoritative in schools and commercial establishments alike. Although the leading textbooks are in close agreement, their authority is limited. A national standard, however, is now in the process of formation under the direction of the American Standards Association. This standard when finally adopted will carry weight in the industries and engineering schools. It should therefore be accepted and be made the standard of practice in teaching drawing in high schools and colleges, as well, since it will represent the combined effort of hundreds of the best qualified leaders of industry, engineering, and the teaching profession."

The writer, being of this opinion, based the tests included in this study on the standards recommended by the American Standards Association.

It has been true many times in the past that quizzing and testing has been overdone, but this is no reason for dropping this method of instruction. If properly used it is still an excellent teaching tool.

Too often a test is thought of as a method of checking up on study or a device that is used to catch the poorly prepared pupil. It may be viewed from a slightly different angle by both pupils and instructors. Its purpose may be to help the pupil see the unity in a great mass of detail, to create another incentive to study, to centralize group thinking on definite fundamentals, or to help a pupil direct his efforts by showing him where he needs further study.

These tests have been designed to help organize and present a part of the fundamentals used in mechanical drawing and to give the pupil experience in using the facts at his command in new situations as they are presented to him.

The instructor should use them as a means of diagnosis. They provide him with information about each individual and for the class as a whole and make it possible for him to direct his own efforts in helping his class more intelligently.

The chapters on spelling, lettering, lines and line work are included for a different reason. The chapter on spelling is included for the purpose of stressing the importance of spelling, to present a list of "key words" with definitions pertaining to drawing, and to give the instructor a method of presentation. The charts on lettering

and lines and line work show another use for large prepared charts. These charts, or charts similar to these, based upon the recommendations of the American Standards Association, should be a permanent part of every mechanical drawing room. They should be conveniently located and used constantly as a means of correcting common errors after they have been used in lecture work and thoroughly explained.

CHAPTER II

SPELLING

The following list of technical words has been selected from the "key words" used in the teaching of mechanical drawing. These words were selected because of the frequency of their appearance in a number of beginning texts in mechanical drawing. The pupil must know these words in order to read a drawing, speak intelligently about mechanical drawing and to understand the explanations and demonstrations the instructor makes.

In the original presentation, the words should be correctly pronounced and the definitions given. If time permits the words should be used in a sentence. In "A Workbook For Beginners--Learning to Read Mechanical Drawings" written by Roy A. Bartholmew and F. S. Orr, the recommendation made in spelling tests is to use ten to twenty words for each lesson.

Some studies included more words than listed here but none were found that included a written definition for each word. This list may be complete or incomplete depending upon the amount of instruction given. The instructor should be as resourceful as the needs of his classes demand in the addition of other words; however, there is no need of teaching spelling for the sake of spelling alone in a mechanical drawing course.

The following list of words is arranged alphabetically for the sake of convenience, however in spelling assignments they must be re-arranged. The instructor should plan the assignments to suit his needs.

Alphabet: The letters of a language arranged in their customary order.

Arc: A portion of a curved line.

Architecture: Art or science of building.

Arrow head: The head of an arrow; as used on a drawing to mark a limit, indicate a note.

Assembly: To fit together the detail parts.

Auxiliary: Offering aid or help, as an extra view.

Axis: A straight line, real or imaginary, passing through a body that actually or supposedly revolves with it. In a working drawing, ~~also~~ a line actually drawn and used as the basis of measurements.

Bow instruments: The smaller compasses of the drawing set, including the bow pencil, bow pen and bow dividers.

Cabinet drawing: An oblique projection. The cross axis may be at any angle, but is usually taken at either 30 or 45 degrees. All measurements parallel to the cross axis are reduced one-half, to overcome the appearance of too much thickness.

Compass: An instrument for describing circles, transferring measurements, etc.

Conventional: Following customary usage in design, technique or principles.

Cross hatch: To cut, engrave or furrow with parallel lines crossing a surface.

Description: Act or result of describing; a sketch or account of anything in words.

Design: To create; to produce a plan for the making of anything; to make a drawing or pattern.

Detail: A minor part such as a detail drawing, made by drawing the whole, item by item.

Development: Patterns of different faces, as in sheet metal, a pattern from which a sheet may be cut that when rolled, folded, or formed will make the object.

Diagram: A line drawing; as for scientific purposes. Any graphic representation.

Dimension: Measure in a single line; usually length, breadth or thickness.

- Divider: An instrument for dividing lines.
- Extension: Act of extending; state of being extended as from one view to another.
- Fillet: A concave junction or molding of two surfaces which form an angle.
- Freehand: Done by hand, as in sketching.
- French curve: An irregular curve used in drawing.
- Geometry: Mathematics that investigates the relations and properties of solids, surfaces, lines, and angles.
- Graphical: Pertains to the arts of painting, drawing, and writing.
- Hexagon: A polygon of six angles and six sides.
- Instrument: A device for doing work or producing an effect; tool; implement.
- Intersect: To pierce, divide, or cut by passing through or across.
- Isometric drawing: A method of pictorial representation.
- Layout: An arrangement or plan.
- Lettering: Act or business of making, or marking with letters.
- Machine drawing: Drawing pertaining to machines; threads, gears, castings, etc.
- Measurement: Act or result of measuring.
- Mechanical drawing: Drawing done with the aid of instruments.
- Oblique: Neither perpendicular nor horizontal; slanting; inclined.
- Octagon: A polygon of eight angles and therefore eight sides.
- Ogee curve: Reverse curve; as in the letter S.
- Orthographic projection: Projection in which the projecting lines are perpendicular to the plane of projection.
- Parallel: Keeping at the same distance, as parallel lines.
- Perspective: Art or science of representing, on a surface, objects as they actually appear to the eye.
- Pictorial drawing: The nature of pictures; graphic.

- Polygon:** A figure having many angles and many sides. (Closed.)
- Prism:** A solid whose bases or ends are similar, equal, and parallel polygons, the faces being parallelograms.
- Projection:** Act or process of projecting on a surface; also, the picture so formed.
- Pyramid:** A figure having for its base a plane polygon and for its sides several triangles with a common vertex and with their bases forming the sides of the base.
- Revolution:** A revolving, or turning about a center or axis.
- Ruling pen:** An instrument used for drawing straight lines in ink.
- Scale:** Anything graduated, when used to measure or rule.
- Section:** A part cut off or separated. Representation of anything as it would appear if cut by a plane.
- Sketch:** An outline; rough draft; a preliminary or incomplete drawing of an object or scene recording its chief features.
- Symbol:** A sign by which one knows a thing.
- Tangent:** Meeting a curve, or surface at only one point, and not cutting it if produced.
- Triangle:** A figure having three sides and three angles.
- Working drawing:** A working drawing gives all the information necessary for the complete construction of the object represented.

SINGLE STROKE COMMERCIAL GOTHIC LETTERING

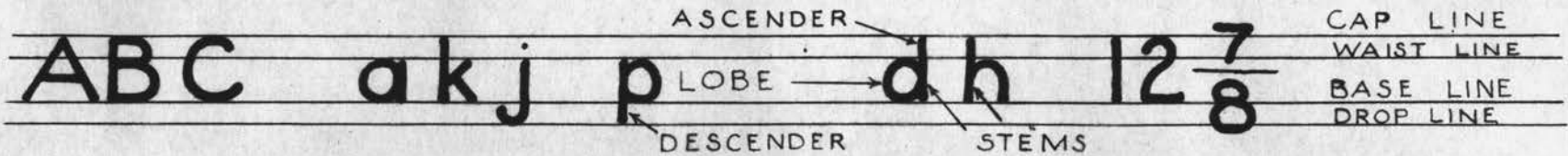

INCLINED

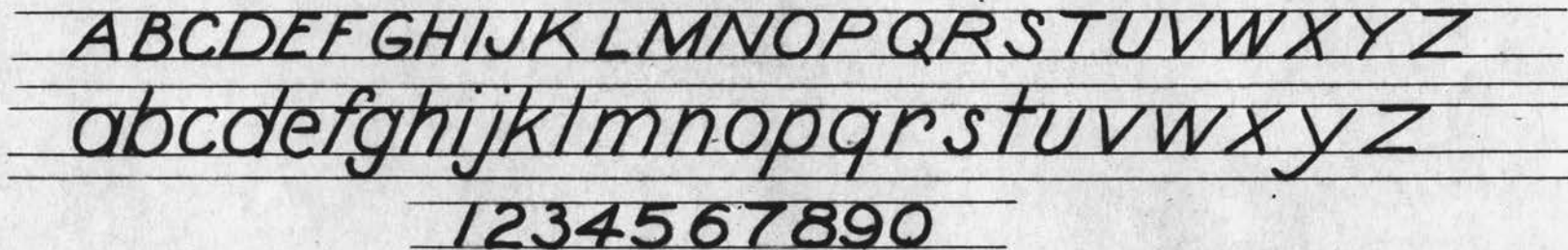

VERTICAL

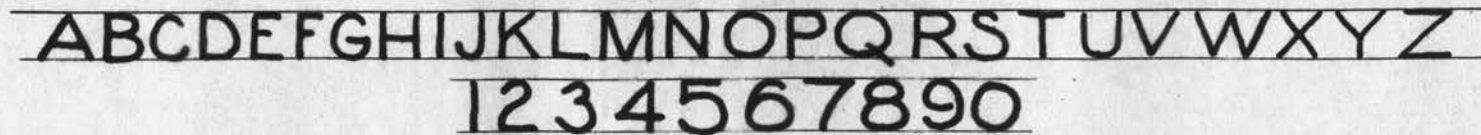

CHAPTER III

LETTERING

This unit of work is included because it presents information and practice needed in successfully learning the work of mechanical drawing and to broaden the students' understanding of alphabets. The following information constitutes the lecture to be given to accompany the chart.

ORIGIN AND DEVELOPMENT OF LETTERING. Lettering is one of the oldest of the Fine Arts. The first symbols of spoken words that we have record of were not letters as we know them today, but crude pictures painted or carved on wood or stone. In reality these pictures were short stories of battles or common incidents in the lives of historic peoples. Gradually certain pictures were used to represent certain definite things and became symbols for words and names. Because of this fact the names of many of the letters in our present day alphabet may be traced back to the original names of the objects they first represented. On the other hand, the making of pictures developed into the arts of drawing and painting, while carving on wood and stone developed into sculpture. In our study of lettering let us not forget that it was one of the stones in the foundation of our present civilization, that it is one of the oldest of the Fine Arts, that it has greatly influenced our present mode of living, and that it still ranks very high as a universal method of expression.

PURPOSE OF LETTERING. In drawing a great many of our ideas can be expressed without the use of words, but not all of them. Some words must be placed on all drawings, such as one's name, school,

date, scale of drawing, and notations. These words and others that will be used from time to time must be well lettered in order to preserve the general good appearance of the drawing sheet. No matter how neat and accurate a drawing may be, if the letters are poorly formed, out of line, and are not of the proper size the entire appearance of the sheet is changed. For this reason, you as students, must place great emphasis on and devote much time to lettering. The ability to letter is of value to everybody and not alone to those engaged in drawing. One who develops such skill will find it useful in personal correspondence, in making place cards and posters, in labeling books, addressing boxes for mailing, and as a hobby.

WHAT IS LETTERING. As one begins the study of drawing he finds some words begin to take on a more definite meaning. For example the word lettering is often spoken of as printing. Let us try to draw some definite line of distinction between the meanings of the two words. Lettering is the method or procedure used in drawing freehand each of the characters of the alphabet and numerals. Let us think of printing as a very different process:---where type is set and machines are used to do rapid duplicate production work. Be careful about the use of these two words: it is a mark of intelligence and training to use technical words in the proper manner.

There are certain terms used in printing and lettering that carry the same meaning. As children, when you first learned to write you soon discovered the alphabet contained two types of letters. These letters were known as capital letters and small letters. In printing and lettering they are known as caps or upper case and lower case letters. These two meanings are taken from the printers arrangement

of his type. We know that in practically all printing more lower case or small letters are used than upper case letters; hence the lower case letters are in the lower division of the case so the one setting the type can reach them more conveniently and more rapidly. The upper case letters or caps are arranged above the lower case letters and are a little more difficult to reach. Numerals are always lettered the same height as the caps. (Fractions of course are an exception to this rule.)

TYPES OF ALPHABETS. One of the first things learned upon entering school was the alphabet. Perhaps since that time the word alphabet has meant but one thing: that is, A, B, C, etc. on to the letter Z. It will be given a much broader meaning in this drawing course. If you will look about you for just one day as you walk about the streets and as you read various printed pages you will soon note that there are many alphabets. In fact there is such a great variety of alphabets that it is beyond the highly specialized show-card writer and printer to memorize them all. Emphasis in this study, will center on the more commonly used alphabets.

GUIDE LINES. One of the prerequisites to good lettering is the making of guide lines, since all good lettering is made a uniform height by the use of such lines. When drawing a guide line always make a fine, light line: make it fine for accurate work and light because it must be removed from finished work. Guide lines used in lettering are:-

Capital line: Line bounding the height of capitals and ascending strokes.

Waist line: Line bounding the height of the body part of lower case letters, at about $\frac{2}{3}$ height of capital.

Base line: Line at base of capital and body part of lower case letters.

Drop line: Line to which long descending strokes are dropped.

PARTS OF A LETTER

Stem: The down stroke, usually vertical.

Ascender: The lower case stroke extending above the waist line to the Cap line.

Descender: The lower case stroke descending below the base line to the drop line.

Lobe: The round bellied section of a letter.

Stroke: That portion of a letter formed with one movement.

Practice should be limited to either the inclined or vertical single stroke commercial gothic letter, because the letters of this style are the simplest to make and they can be made more rapidly.

The following standard practice is recommended by the American Standards Association.

"That single stroke commercial gothic lettering either vertical or inclined at a slope of 2 in 5 be used on all working drawings for titles, notes, etc.

That only capitals be used in the title box.

That for notes, bills of material, etc., if the vertical style is chosen the letters should all be caps. If the inclined style is chosen the letters may be all caps or caps and lower case.

It is not desirable to grade the size of the lettering with the size of the drawing except when a reduced photographic reproduction of the drawing is to be made. In other words the size and weight of the lettering should be such as will produce legible prints from tracings either in pencil or in ink.

Lettering should not be underlined except for particular emphasis."

Correct examples are necessary in teaching lettering. When the pupil is doing lettering exercises he should have before him a correct form of the letters he is to make. Lettering is merely a process of imitation and memory, and keen observation is absolutely necessary. Successful progress cannot be made without having a mental image of the correct letter shapes and no beginning pupil will have that image until he has had before him and actually used a correct model.

5 YOUR NAME
 0 9 8 7 6 5 4 3 2 1 0 9 8 7 6 5 4 3 2 1
 0 9 8 7 6 5 4 3 2 1 0 9 8 7 6 5 4 3 2 1
 0 9 8 7 6 5 4 3 2 1 0 9 8 7 6 5 4 3 2 1

6 YOUR NAME
 AAA BBB CCC DDD EEE FFF GGG HHH III
 JJJ KKK LLL MMM NNN OOO PPP QQQ RRR
 SSS TTT UUU VVV WWW XXX YYY ZZZ MNZ

7 YOUR NAME
 TALKING AND BORROWING CAN SOON BECOME BAD HABITS.
 WHEN IN DIFFICULTY LET THE INSTRUCTOR ASSIST YOU.
 DON'T MAKE EXCUSES**MAKE ACCURATE AND NEAT DRAWINGS.

8 YOUR NAME
 WHEN IT IS TIME TO CEASE DRAWING BE SURE EVERYTHING IS IN ITS PROPER
 PLACE, AND THAT THE DESK IS CLEAN. STAY IN YOUR PLACE UNTIL TIME TO
 PASS.

9 YOUR NAME
 LINES COMMONLY USED IN MECHANICAL DRAWING ARE, OUTLINE OF PARTS,
 DIMENSION AND EXTENSION LINES, HIDDEN LINES, CENTER LINES, CUTTING
 PLANE LINES, SECTION LINES, AND BREAK LINES.

10 YOUR NAME
 INSTRUMENTS USED IN ORDINARY DRAFTING ARE: THE DRAWING BOARD, T-SQUARE,
 45 DEGREE AND 30-60 DEGREE TRIANGLES, SCALES, COMPASSES, LENGTHENING
 BAR, PEN ATTACHMENT, BOW INSTRUMENTS, AND THE RULING PEN.

11 YOUR NAME
 KEEP THE DRAWING PENCIL SHARP.
 DO NOT USE THE T-SQUARE FOR A HAMMER.
 KEEP THE HANDS AND INSTRUMENTS CLEAN.

12 YOUR NAME
 DO NOT DRAW WITH THE LOWER EDGE OF THE T-SQUARE.
 THE DIVIDERS SHOULD NEVER BE JABBED INTO THE DRAWING BOARD.
 THE MOUTH SHOULD NOT BE USED FOR A PENCIL HOLDER.

13 YOUR NAME
 ACCURACY FIRST
 ALL DRAWINGS SHOULD BE CORRECT, NEAT, WELLPLACED AND STAND OUT CLEARLY.

14

YOUR NAME

THE MOST IMPORTANT REQUIREMENTS FOR LETTERING, AS USED IN MECHANICAL DRAWING, ARE LEGIBILITY AND RAPIDITY OF EXECUTION.

15

YOUR NAME

WORDS COMMONLY USED IN DRAWING--DIMENSIONS, CIRCLES, ARCS, TANGENTS, FILLETS, ANGLES, SKETCHING, ISOMETRIC, OBLIQUE, OCTAGON, PYRAMID, ARROW HEAD, ORTHOGRAPHIC.

16

YOUR NAME

MANY ARTISTS SPECIALIZE IN LETTERING. THEY FIND A STEADY AND EVER GROWING DEMAND FOR THEIR WORK THAT KEEPS THEIR HANDS AND MINDS BUSY.

17

YOUR NAME

MUST YOUR SUPERVISOR CARRY AN OIL CAN.
A GOOD WORKMAN IS NEVER OVERPAID.
LET NOT THY HANDS BE SLACK.

18

YOUR NAME

FINE CARVINGS ARE NOT MADE FROM ROTTEN WOOD.
DECAYED TREES DO NOT WITHSTAND GREAT STORMS.
BETTER WEAR OUT THAN RUST OUT.

CHAPTER IV

LINES AND LINE WORK
(Lecture to accompany chart)

The purpose of this unit is to present the alphabet of lines used in mechanical drawing in a usable form for lecture work and class discussion. Very few of the drawing texts include both a drawing and written description of each line and a few depend entirely upon the instructor for clarification. The use of this chart will save the instructor a part of the time generally spent in blackboard work. It is necessary for the pupils to know the characteristics, meaning, and definitions of these lines before they can proceed intelligently with their drawing. This material also serves as a basis for the tests that follow.

A brief description of the line as well as its correct name and shape is given on the chart. The pupil should not be required to learn or memorize the entire chart at one time. In most cases the textbooks start with three kinds of lines in the first drawing, namely, outline of parts, dimension lines, and extension lines. If this is the case the pupil should be required to know these three lines when he starts his first drawing. The remaining lines should be learned as they are brought into use.

This chart should be conveniently located in the drawing room and available at all times except when a quizz is given on any form of lines and line work.

The remaining material included in this unit is written for the benefit of the instructor. The writer has attempted to assemble a portion of the information used in demonstrations and discussions on

on types of lines and their uses by draftsmen.

The names of lines, their shape, and their definitions have been based on the recommendations of the American Standards Association.

LINES AND LINE WORK

Outline of parts:

Heavy

"The outline should be the outstanding feature and the thickness may vary to suit the size of drawing."

This line is used in representing all lines of an object that can be seen from a given position.

Dimension and extension lines:

Light

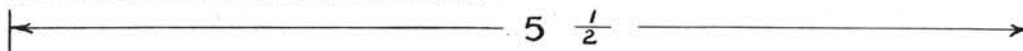

"Lines unbroken, except at dimensions. Dimension lines should be made as light lines, unbroken except for the space left for the dimensions. Extension lines should be fine full lines of the same weight as dimension lines. They should not touch the outline of the subject."

The bar dividing the fraction should be drawn at the same time the dimension line is drawn. This is never drawn freehand.

Hidden lines:

Medium



This line is made up of short dash lines as shown and is used to form the outline of all edges of an object that cannot be seen from a given position. As few hidden lines as practicable should be used; sections are preferable in many cases.

Center lines:

Light



The center line is a broken line, made up of long and short dashes, alternately spaced. This line is used to locate the centers of circles and to designate the center of objects having identical halves.

Cutting plane line:

Heavy

"A broken line made up of one long and two short dashes, alternately spaced. The cutting plane on which the section has been taken should be indicated by a heavy broken line consisting of one long and two short dashes alternately spaced, and lettered at the ends. Arrows are used to indicate the direction in which the section is viewed. On simple symmetrical objects the heavy line, letters, and arrows may be omitted. It is not necessary that the cutting plane be a single continuous plane; it may be bent or offset if by so doing the construction can be shown to better advantage. The reference letters should be repeated at points of change in direction unless the changes are short and frequent. When the cutting plane extends entirely across the object a 'full section' is obtained. A symmetrical object may be drawn as a 'half-section' showing one-half, up to the center line, in section, and the other half in full."

The cutting plane line is used to locate the position or place where an object is cut to show a section.

Section Lines:

Light

"Section lining should be made with light parallel lines at an angle of 45 degrees with the border line of the drawing and spaced from 1/32 inch to 1/8 inch apart depending on the size of the drawing and of the part. Two adjacent parts should be sectioned in opposite directions. A third, adjacent to both, should be sectioned at 30 degrees or 60 degrees. If cut in more than one place the sectioning of any part should be the same in direction and spacing. If the shape or position of the part would bring 45 degree sectioning parallel or nearly parallel to one of the sides, another angle should be chosen."

Break lines:

Heavy

Light

"A freehand line is used to show short breaks; while a ruled line and freehand zigzags for long breaks. Break lines may be used on both detail and assembly drawings. On small parts heavy freehand lines are best, while on assemblies or large parts the second form, made with light ruled lines with freehand 'zigzags' is preferred."

Ditto line:

Medium

Indication of repeated detail. This line is often used in arch-

itectural drawing and furniture design to show a repeated detail as a molding in furniture design or a detail of carving.

Adjacent parts and
alternate positions:

Medium

"Adjeacent parts and alternate positions are shown by a broken line made up of long dashes. An alternative position, or indication of the limiting positions of a moving part should be shown by a line made up of long dashes of medium weight. Adjacent parts added on a drawing to indicate the position or use of the piece represented, are drawn with the same symbol of long dash lines. This line is also used in showing machine bosses and lugs cast on for holding purposes, which are to be removed later."

This chart is to be used for lecture purposes and instruction, not as a testing device. It should be conveniently located in the drawing room and used constantly as a means of correcting common errors made by the pupils.

*

LINES AND LINE WORK

OUTLINE OF PARTS:

HEAVY

The outline should be the outstanding feature and the thickness may vary to suit the size of the drawing. This line is used in representing all lines of an object that can be seen from a given position.

DIMENSION AND EXTENSION LINES:

LIGHT

 These lines are unbroken except for the space left for the dimensions. Extension lines should be the same weight and should never touch the outline of the object.

HIDDEN LINES:

MEDIUM

 This line, made up of short dashes, is used to form the outline of all lines of an object that cannot be seen from a given position.

CENTER LINE:

LIGHT

 This is a broken line, made up of long and short dashes, alternately spaced, and is used to locate the centers of circles and the center of objects having identical halves.

CUTTING PLANE LINES:

HEAVY

 This line is made up of one long and two short dashes, alternately spaced, and is used to locate the place where an object is cut to show a section.

SECTION LINES:

LIGHT

 The exposed cut surface of material is indicated by "section lining" or "cross hatching" with uniformly spaced lines. Example: used in representing material cut by the cutting plane line.

BREAK LINES:

LIGHT



HEAVY



A freehand line is used for short breaks while a ruled line with freehand zigzags is used for long breaks. These lines are used to show where sections of material have been omitted.

ADJACENT PARTS AND ALTERNATE POSITIONS:

MEDIUM

Used in showing the limiting positions of moving parts.

CHAPTER V

TESTING THE PUPIL'S ABILITY TO READ THE SCALE

PURPOSE OF THE TEST:

The purpose of this test is to determine the pupil's ability to read the scale. Often the junior high school pupil will ask such questions as, "How large is the smallest division on this ruler?", "How much is one-half of one and three-fourths?", or, "I know how much one half of three and seven-eighths is but I can't find it on this ruler." One is often led to believe a few of the junior high school pupils have never been called upon to use the scale for taking measurements in any form. The scale is used from the beginning in mechanical drawing and certain fundamentals should be reviewed for those who apparently have the knowledge of its use as well as for that group who will invariably ask the simple questions.

AMOUNT AND KIND OF WORK TO BE DONE BEFORE GIVING THE TEST.

Before giving the test in reading the scale it is necessary to give a brief lecture. The enlarged drawing of the scale is very useful for this work, however it will be necessary to cover the questions on the chart. This is easily done by clipping ordinary wrapping paper to the chart with paper clips. In such a lecture point out one-sixteenth, one-eighth, one-quarter, one-half, and one inch. If the smallest division on the scale is one-sixteenth of an inch it will be found profitable to show how to determine fractions in thirty-seconds of an inch. It is also necessary to give a brief review of addition, subtraction, multiplication, and division of fractions. Explain definitely that it is incorrect to say or write $8/16$, $6/8$, $2/4$, $18/16$, or seven

and one-half-sixteenths, and that all fractions must be reduced to their lowest terms.

MATERIALS NECESSARY:

An enlarged drawing of the test as shown, a sheet of clean paper, a pencil, and an eraser for each pupil.

INSTRUCTIONS FOR GIVING THE TEST:

After making certain all materials are available have the pupils fill out the type of heading (Name, name of test, date, classification, etc.) that will best fit local school needs. The test shall be answered as follows; $A \text{ to } B = ?$, $A \text{ to } C = ?$, etc. The pupil should start working as soon as he is instructed to do so. He should work as rapidly as possible, reduce all fractions to their lowest terms, and should not stop until he had finished or until time is called.

When approximately three-fourths of the class have finished the test, time should be called. Have the pupils exchange their papers so that no pupil can check his own. As the answers are read have each pupil check the mistakes on the paper he is grading. When all answers have been read and all mistakes have been checked the number of mistakes should be written at the top of the sheet and then handed back to its owner.

USE TO BE MADE OF RESULTS:

As soon as the papers have been returned all questions should be answered immediately.

After checking all papers, those making a good score, and by so doing prove they understand the items covered in the test, should proceed with their assigned work. All those making a poor score should be assembled at a convenient place for special instruction.

From the writer's past experience, the failure of a pupil to make a creditable score can be traced to four main causes. The pupil cannot read a scale, cannot reduce fractions, is too slow, or has poor eye sight.

To correct these weaknesses permit the pupil to do the test again with no time limit and answer all questions while the review is in progress. Also have the pupil measure various objects. If the pupil has difficulty in reducing fractions, explain the procedure again and give him a list of fractions to reduce. Do not hurry the slow pupil; accuracy is more important. If the pupil has difficulty with his eyes be sure to place him advantageously in the room. Follow the policy of your school in reporting such cases.

TESTING YOUR ABILITY TO READ THE SCALE

HOW FAR IS IT FROM:---

A to B----- $1/16$
 A to E----- $2 \frac{3}{16}$
 A to H----- $4 \frac{1}{16}$
 B to C----- $1 \frac{3}{8}$
 C to E----- $13/16$
 E to F----- $3/4$
 A to C----- $1 \frac{7}{16}$
 A to F----- $2 \frac{15}{16}$
 A to I----- $4 \frac{3}{8}$
 B to E----- $2 \frac{1}{8}$
 C to H----- $2 \frac{5}{8}$
 E to H----- $1 \frac{7}{8}$
 A to D----- $1 \frac{9}{16}$
 A to G----- $3 \frac{1}{8}$
 A to J----- $4 \frac{3}{4}$
 B to I----- $4 \frac{5}{16}$
 C to J----- $3 \frac{5}{16}$
 E to I----- $2 \frac{3}{16}$
 C to D----- $1/8$
 D to E----- $5/8$
 E to F----- $3/4$
 F to G----- $3/16$
 G to H----- $15/16$
 H to J----- $11/16$

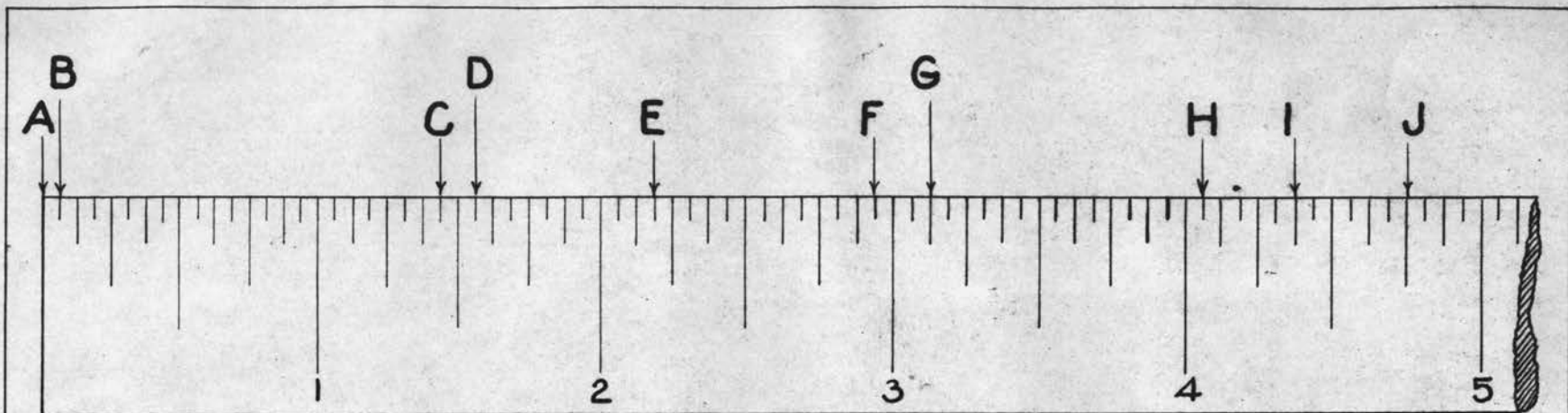

HOW FAR IS IT FROM

A TO B
 A TO E
 A TO H
 B TO C
 C TO E
 E TO F

A TO C
 A TO F
 A TO I
 B TO E
 C TO H
 E TO H

A TO D
 A TO G
 A TO J
 B TO I
 C TO J
 E TO I

C TO D
 D TO E
 E TO F
 F TO G
 G TO H
 H TO J

CHAPTER VI

TESTING YOUR ABILITY TO JUDGE ANGLES

PURPOSE OF THE TEST:

The purpose of this test is twofold; first, to test the pupil's ability to judge angles, and second, to promote a closer observation of angles. One of the chief difficulties, in the teaching of mechanical drawing, is the assumption that correct observation will be made without specifically directed attention. It is an unsound belief that because a thing is illustrated in a textbook, blueprint, or in some drawing to which the pupil has access that he will make the correct observations. His attention must be specifically and consciously directed to the thing he is to see.

These tests require a minimum of time, yet they attach a degree of importance to the use of the triangles and do stimulate the pupil to observe more closely.

AMOUNT AND KIND OF WORK TO BE DONE BEFORE GIVING THE TEST:

A part or an entire class period should be devoted to a lecture on the use of the triangles. It is necessary to stress the importance of knowing the triangles and the relative size of each angle. Ample time should be spent in a demonstration, clearly showing how the triangles are used and how they are combined to make any angle which is divisible by fifteen. The pupil should be required to draw the following angles; 30, 45, 60, 75, 90, 105, 120, 135, 150, and 165, divide a circle into 8 equal parts with the T-square and 45 degree triangle, divide a circle into 12 equal parts with the T-square and 30-60 degree triangle, and divide a circle into 24 equal parts with

the T-square, and both triangles.

MATERIALS NECESSARY:

Each pupil should have a pencil, an eraser, and two sheets of paper, one for the answers to the questions and one to use in computing the various angles. An enlarged drawing of the test should be at hand.

INSTRUCTIONS FOR GIVING THE TEST:

Before giving instructions make certain that each pupil has his materials. Have the pupils fill out the heading (name, name of test, date, classification, etc.) that will best fit local school needs. The test shall be answered as follows: $A = ?$, $B = ?$, etc. Explain clearly that all angles are formed with the T-square, 30-60 degree, and 45 degree triangles and that all angles are multiple of 15 degrees.

The pupil should start work as soon as he is instructed to do so, he should work as rapidly as possible, refrain from asking questions, and continue to work until he has finished the test or until time is called.

When approximately three-fourths of the class have finished the test, time should be called. Have the pupils exchange their papers so that no pupil can check his own. As the answers are read have each pupil check the mistakes on the paper he is grading. When all answers have been read and all mistakes have been checked, the number of mistakes should be written at the top of the sheet and then handed back to its owner.

USE TO BE MADE OF RESULTS:

As soon as the papers have been returned all questions should be answered.

After checking all papers, those making a good score, and by so doing prove they understand the items covered in the test, should proceed with their assigned work. All those making a poor score should be assembled at a convenient place for special instruction.

To help the pupil who has had difficulty with this test, have him take the test again, with no fixed time limit and answer his questions while the review is in progress. When he has answered all the questions permit him to check his answers by using his triangles on the test. It will also be found helpful to assign a list of angles for the pupil to construct.

Since the second test is much more difficult than the first, the instructor is the best judge of when and how to use it. These tests are designed as learning aids for the pupil and not as devices used in securing grades. Their chief function is to help the pupil find his errors and correct them.

TESTING YOUR ABILITY TO JUDGE ANGLES. (1)

A-----45 Degrees

B-----60

C-----30

D-----45

E-----60

F-----30

G-----30

H-----45

I-----45

J-----60

K-----30

L-----60

M-----45

N-----45

O-----60

P-----30

Q-----60

R-----30

S-----90

T-----30

U-----30

V-----30

W-----45

X-----45

Y-----180

TESTING YOUR ABILITY TO JUDGE ANGLES. (2)

A-----135

B----- 30

C----- 15

D-----120

E-----150

F----- 75

G----- 45

H-----105

I----- 90

J-----120

K----- 75

L----- 90

M-----105

N----- 75

O-----135

P-----270

Q-----105

R----- 60

S----- 30

T-----120

U-----150

V-----105

W----- 15

X-----330

Y-----255

Z-----255

TESTING YOUR ABILITY TO JUDGE ANGLES

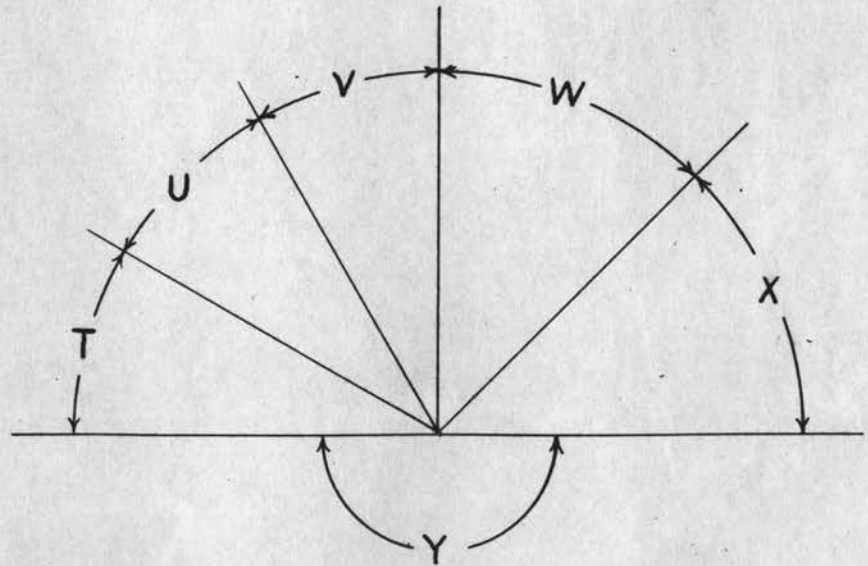
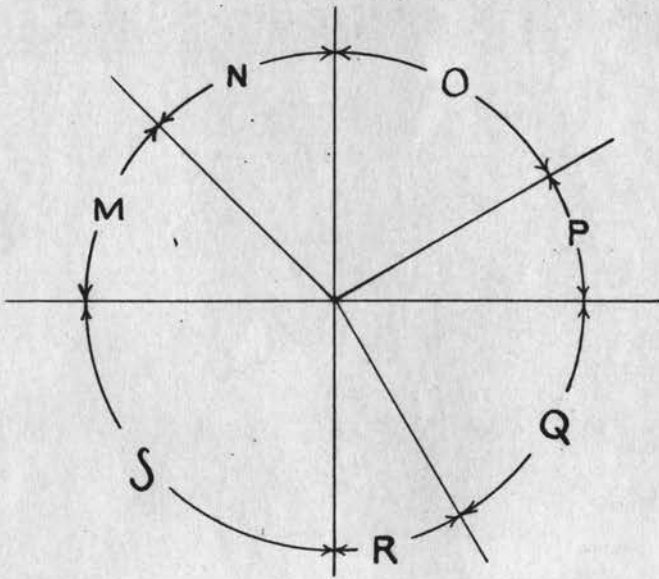
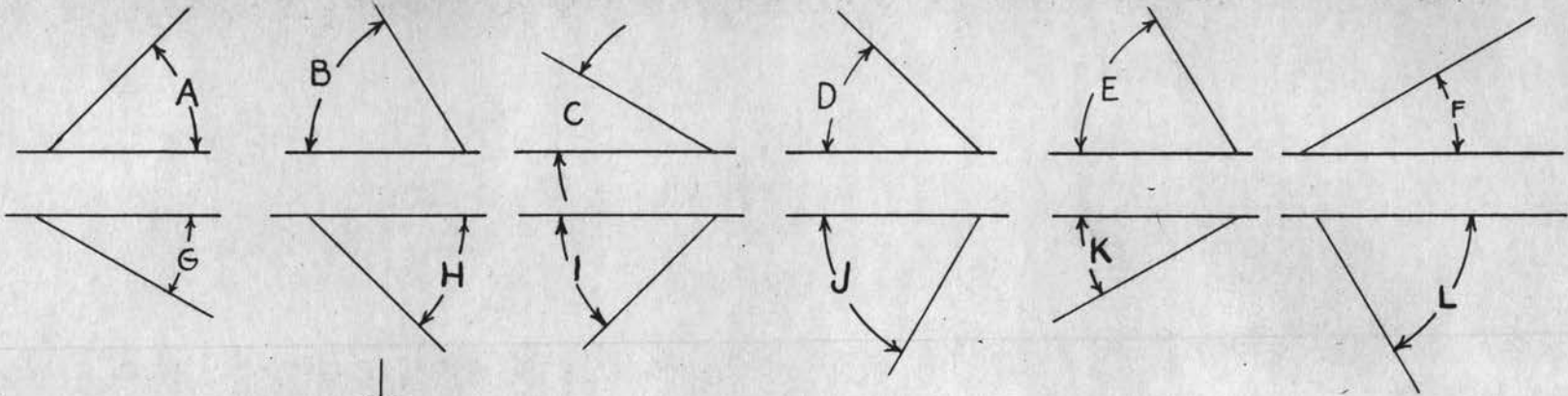

TESTING YOUR ABILITY TO JUDGE ANGLES

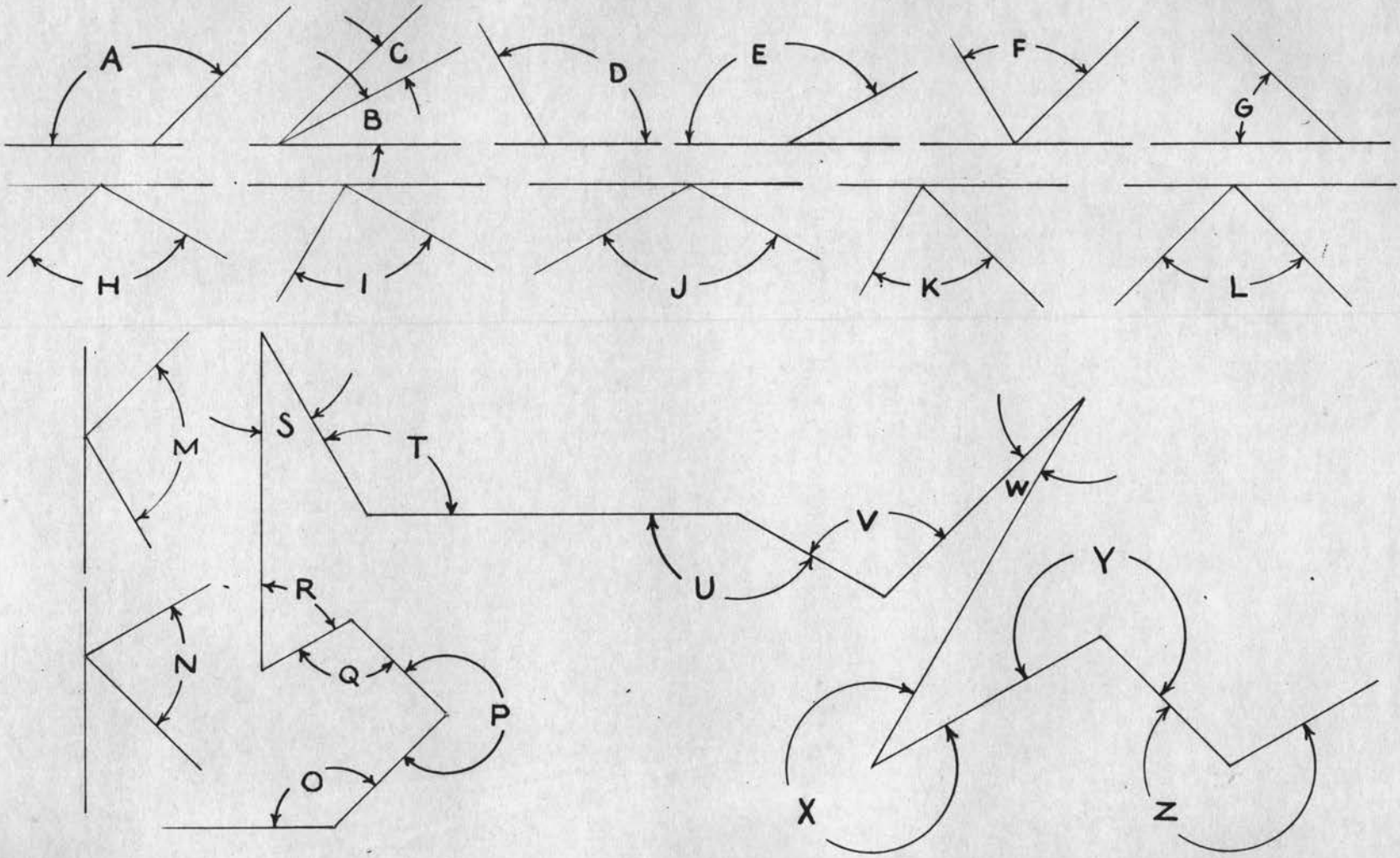

CHAPTER VII

ESSAY TEST IN FINDING ERRORS IN DRAWINGS

PURPOSE OF THE TEST:

The essay type questions which require the pupils to make a complete statement of a fact or principle are the most difficult to score. They present many difficulties in evaluating their worth and require much time to check. They should not be omitted for this reason, because the pupil should have an opportunity to express himself in words. Many write sentences which have no meaning at all and spelling again becomes a subject of importance. The training provided in this form of expression is by no means a small part of the educational value of mechanical drawing.

The purpose of this test is to point out the most common mistakes made by beginners, to give the pupils an opportunity to see and criticize a drawing where mistakes have been made, to call attention to minor details, to add a degree of importance to spelling, and to give the instructor some concrete examples to use before the entire group in clarifying their questions.

AMOUNT AND KIND OF WORK TO BE DONE BEFORE GIVING THE TEST:

This test should not be given until the pupils have completed five or six drawings. Many of the points covered in this test will have been explained by this time, however there will be some that the pupils will not understand. This will give the instructor an opportunity to center the interest of the class on more advanced information that will be needed by the entire group.

MATERIALS NECESSARY:

It is necessary to have two enlarged drawings as shown, one in the incorrect form and one in the correct form. Each pupil should have a clean sheet of paper, a pencil, and an eraser.

INSTRUCTIONS FOR GIVING THE TEST:

After making certain all materials are available, have the pupils fill out the heading (name, name of test, date, classification, etc.) that will best fit local school needs. Explain how the test shall be answered, as shown below.

- A- Make a brief but complete statement of exactly what is wrong
- B- with each point.
- C-

No questions should be asked while the test is in progress. The pupil should begin work when instructed to do so, work as rapidly as possible, use correct spelling, and continue to work until he has finished the test. When finished he should hand the test to the instructor and continue with his assigned work.

USE TO BE MADE OF THE RESULTS:

The instructor should check the tests briefly so that he may become more ~~familiar~~ with the pupils greatest problems and to outline some corrective criticisms for the next meeting of the class. It will be found worth while to place some emphasis upon such fundamentals as spelling, neatness, importance of knowing the alphabet of lines, and other terms used in mechanical drawing.

At the next meeting of the class have each pupil get a clean sheet of paper, a pencil and eraser. Tell the group they are going to receive the correct answers for yesterdays test. Place both of

the large sheets where the class can see them and then have them write the answers as given. Answer all questions asked by the class as you proceed. Be sure to make each point clear. After all questions have been answered return the test papers to the group and have each pupil score his own test. When he has checked his test have him write the number he has answered correctly and the number he has missed at the top of the sheet, then collect the pupils work for final grading.

What Is Wrong With This Drawing?

- A--The Dimension is placed upside down.
- B--Arrow head is filled in solid.
- C--Extension line touches the outline of parts.
- D--The number 7 should be followed by the letter D to signify the diameter.
- E--Dimension lines should be in line with the center of the circle.
- F--The number 1 should be followed by the letter R to signify the radius.
- G--Curved lines are not tangent.
- H--Curved line is not tangent to the straight line.
- I--Arrow heads are not formed with straight lines.
- J--The line dividing the numerator and the denominator should be in line with the dimension line.
- K--Arrow head left off of the dimension line.
- L--The line dividing the numerator and the denominator should be in line with the dimension line.
- M--The center line should extend past the arrow head.
- O--Over-all dimensions should be placed outside the intermediate dimensions.
- P--All dimensions should be placed so as to read in the direction of the dimension lines.
- Q--A center line should never be used as a dimension line.
- R--Dimension lines omitted.
- S--The outline of parts should go through the entire thickness.
- T--Corner has been over run.
- U--Corner has not been completed.
- V--Dimension is too crowded.

WHAT IS WRONG WITH THIS DRAWING?

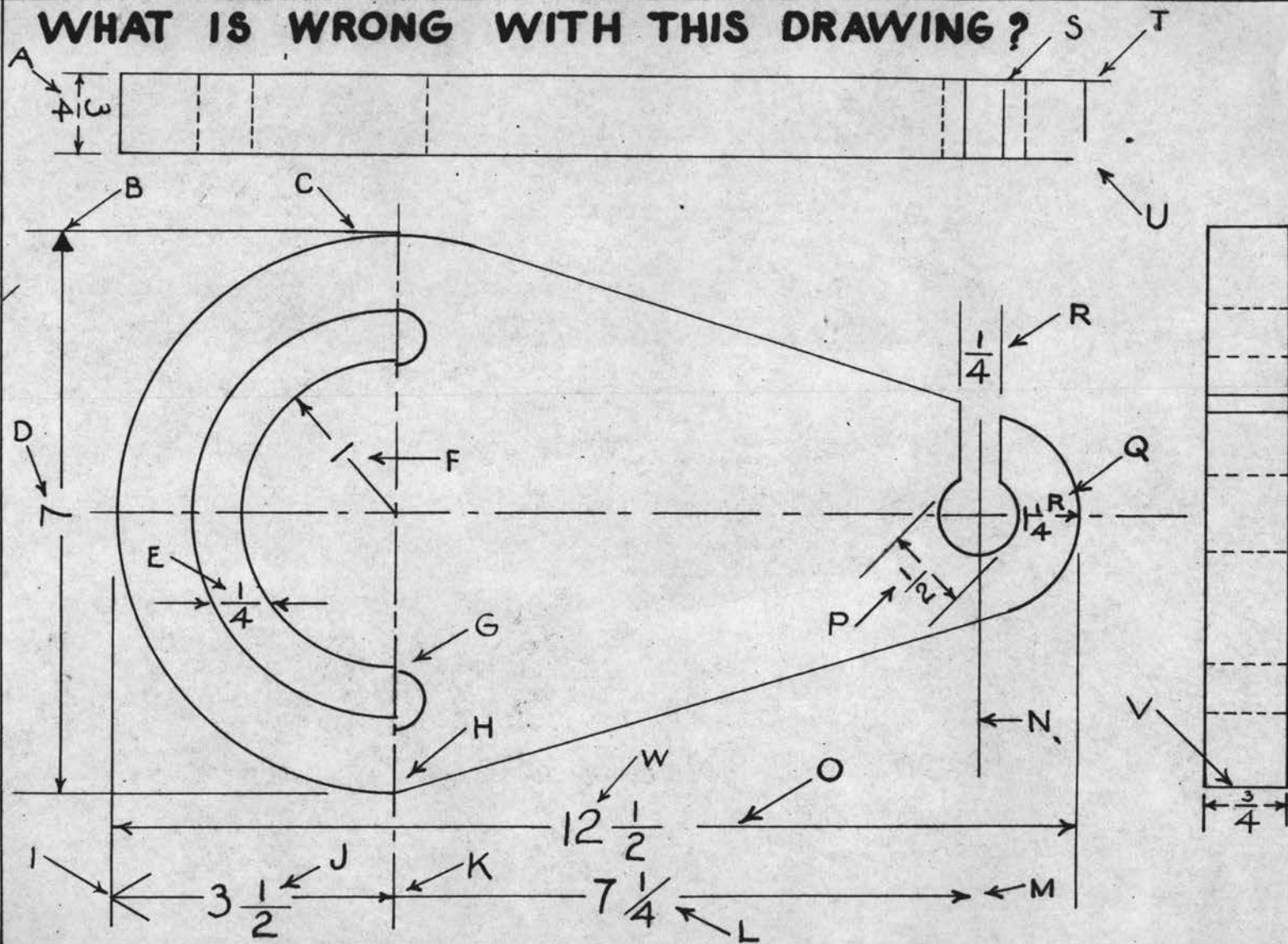

CHAPTER VIII

TESTING YOUR ABILITY TO CHOOSE THE PROPER LINE FOR THE PROPER PLACE

PURPOSE OF THE TEST:

The purpose of this test is to determine the pupils ability to read a drawing, to recognize proper lines in their proper places, and to provide an additional opportunity to check on spelling.

There is no one best approved method of making plans or of teaching, but the making of a plan does involve certain things which must ultimately be done. It is the aim of every instructor to make a fair distribution of his time. If is necessary that each pupil shall recieve enough time to keep moving forward at his maximum rate of speed. Sometimes considerable time is lost by students waiting for the instructors assistance. Occasionally an entire class gets held up until the instructor finds that everybody is having difficulty with the same thing. When this situation arises the class is called together for a general explanation. One of such problems will be made less difficult through the use of this test because the problem has been ascertained.

MATERIALS NECESSARY:

It is necessary to have an enlarged drawing of the test as shown and for each pupil to have a sheet of paper, a pencil and an eraser.

INSTRUCTIONS FOR GIVING THE TEST:

After making certain all material is available have the pupils fill out the heading (name, date, classification, name of test, etc.) on their answer sheets that will best fit local school needs.

Explain how the test is drawn. All lines are solid lines and the same weight, which is not the correct practice for commercial drawings. It is necessary to read and understand the drawings before the proper line is selected.

To keep the answer sheets uniform they should be lettered from A to Y on the first test and answered as follows:

A- Name of the correct line.

B- Name of the correct line. Etc.

Questions should not be asked while the test is in progress.

The pupil should begin work when instructed to do so, work as rapidly as possible, make certain spelling is correct, and work until he has finished.

When all have finished have the pupils exchange their papers for grading. Read the answers and have the pupils check all mistakes and write the number wrong at the top of the sheet.

This test also provides an excellent check on spelling. Write the names of the lines on the board or use the large drawing of "Lines and line work," previously explained and have the pupils check their spelling.

Have the papers returned so the pupils may ask questions. Answer these questions immediately and in detail if necessary to explain why a certain line is used in a certain place.

USE TO BE MADE OF RESULTS:

Those making a creditable score, and by so doing prove they understand the principles involved in this test, should proceed with their assigned work.

Those making a poor score should be assembled at a convenient time

for special instruction.

The cause for a low score on this particular test can be traced to two main difficulties. First; the inability of the pupil to visualize a working drawing, and second, a poor understanding of the various lines and their functions.

Determine the cause and correct the weakness by making another explanation of the functions of the various lines, by having the pupils study the definitions and shapes of lines, and by giving drills similar to this test.

If the pupil's spelling is poor he should be held responsible for the correct spelling in the near future.

Little or no instruction will be required for the second test. The purpose of the second test is to give more drill in determining correct lines and to check the special instruction given to the slower pupils on the first test. The results of these tests are not used in grading students, but only for remedial purposes.

Testing Your Ability To Choose The Proper
Line For The Proper Place (1)

A-----Outline of parts
B-----Dimension line
C-----Extension line
D-----Extension line
E-----Hidden line
F-----Outline of parts
G-----Hidden line
H-----Break line
I-----Outline of parts
J-----Hidden line
K-----Hidden line
L-----Outline of parts
M-----Dimension line
N-----Center line
O-----Hidden line
P-----Center line
Q-----Dimension line
R-----Outline of parts
S-----Hidden line
T-----Center line
U-----Cutting plane line
V-----Center line
W-----Hidden line
X-----Outline of parts
Y-----Section lines

Testing Your Ability To Choose The Proper
Line For The Proper Place. (2)

A-----Outline of parts
B-----Hidden line
C-----Extension line
D-----Dimension line
E-----Hidden line
F-----Outline of parts
G-----Center line
H-----Hidden line
I-----Dimension line
J-----Outline of parts
K-----Outline of parts
L-----Hidden line
M-----Dimension line
N-----Outline of parts
O-----Center line
P-----Outline of parts
Q-----Cutting plane line
R-----Outline of parts
S-----Center line
T-----Extension line
U-----Hidden line
V-----Outline of parts
W-----Outline of parts
X-----Outline of parts
Y-----Section lines
Z-----Hidden line

TESTING YOUR ABILITY TO CHOOSE THE PROPER
LINE FOR THE PROPER PLACE

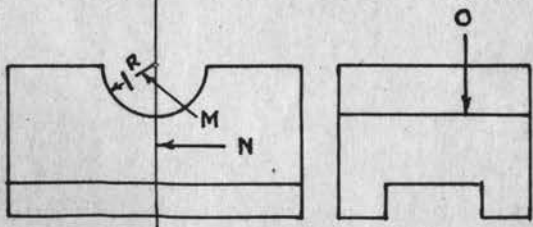
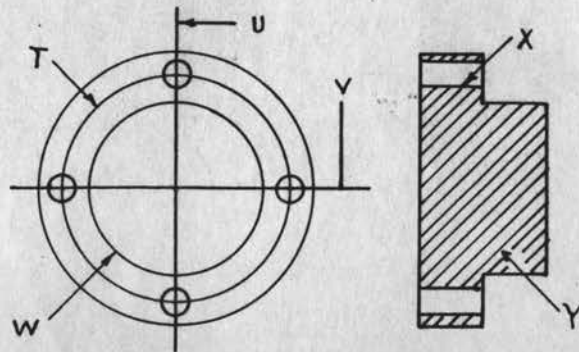
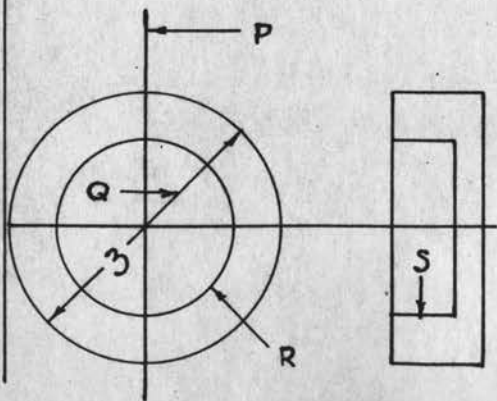
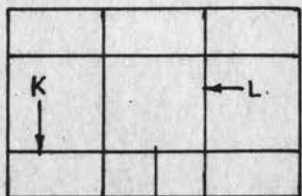
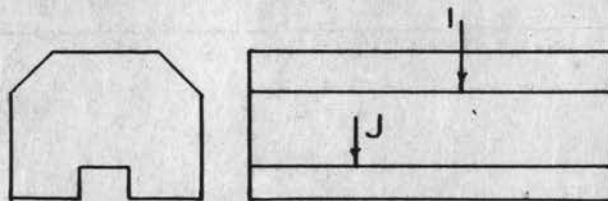
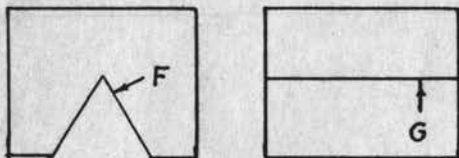
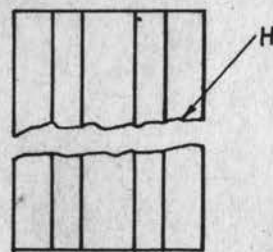
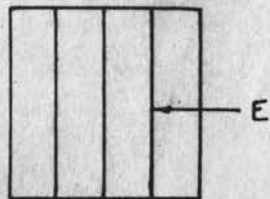
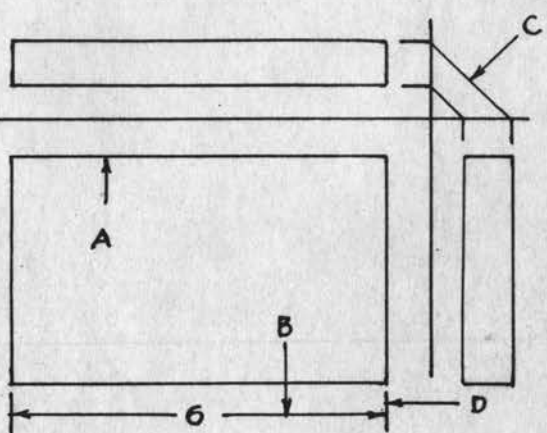

TESTING YOUR ABILITY TO CHOOSE THE PROPER
LINE FOR THE PROPER PLACE.

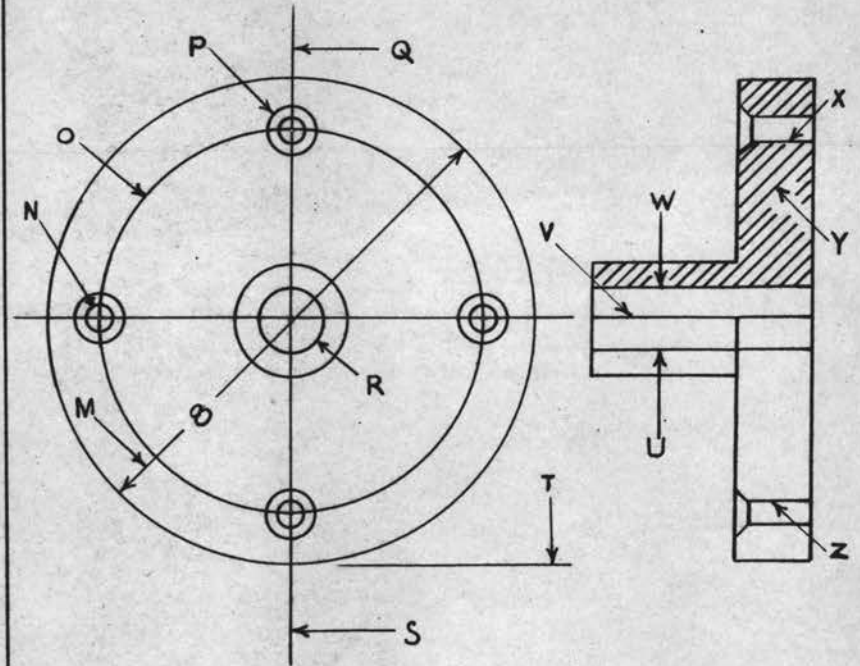
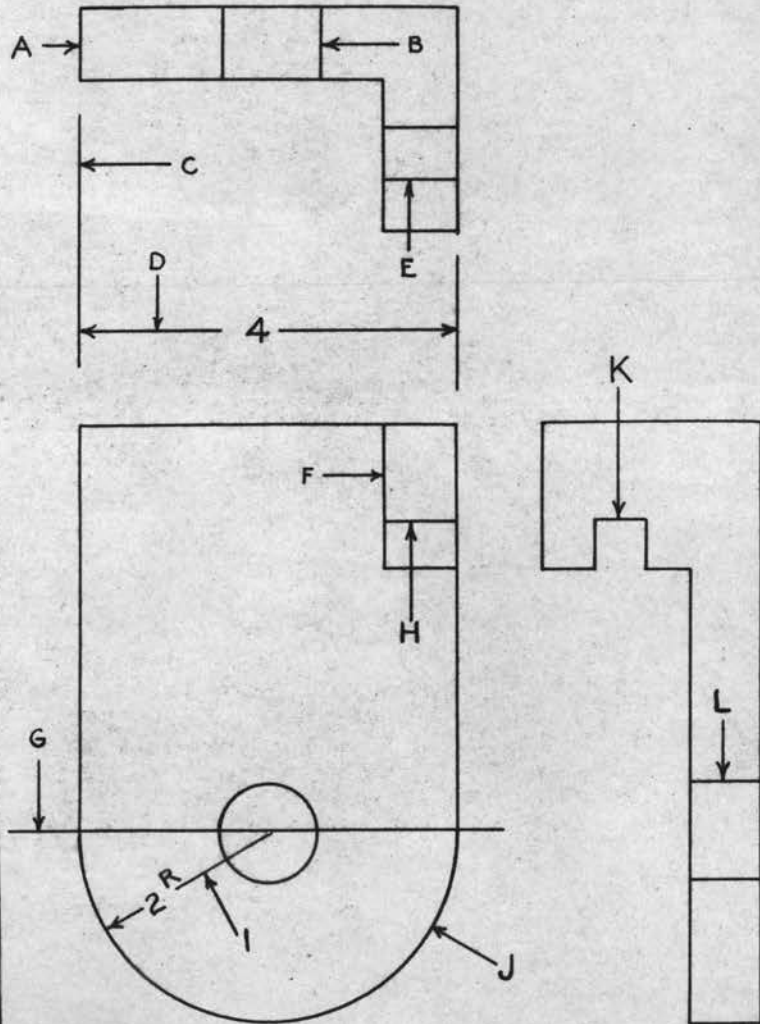

CHAPTER IX

TESTING YOUR ABILITY TO DETERMINE CORRECT DIMENSIONS

PURPOSE OF THE TEST:

This test will give the pupils a drill in reading a drawing, help them to observe drawings more closely, give them a better understanding of how and where to look for dimensions, as well as how to place them on a drawing.

In this test, two or three views of an object are given and sometimes a pictorial drawing is included. A sufficient number of dimensions are given so that all dimensions called for can be correctly computed. It will be necessary for the pupils to add, subtract, and divide fractions. Although such problems seem comparatively simple it is surprising how much mental stimulation and valuable observation they provide.

AMOUNT AND KIND OF WORK TO BE DONE BEFORE GIVING THE TEST:

Working drawings should be fully explained and three or four drawings should have been completed by each pupil prior to taking this test.

MATERIALS NECESSARY:

It will be necessary for each pupil to have a sheet of paper, a pencil, and an eraser. An enlarged drawing of the test is also necessary.

INSTRUCTIONS FOR GIVING THE TEST:

After making certain all materials are available, have the pupils fill out the heading (name, name of test, date, classification, etc.) on their answer sheets that will best fit local school needs.

Explain clearly how the test shall be answered; as, for example, $A = ?$, $B = ?$, $C = ?$, etc., that it may be necessary to add, subtract,

or divide fractions, and that all fractions must be reduced to their lowest terms.

The pupils should not ask questions while the test is in progress. They should begin work when instructed to do so, work as rapidly as possible, and not stop until finished.

When all have finished have the pupils exchange their papers for grading. Read the answers, have the pupils check all mistakes, and write the number wrong at the top of the sheet. Have papers returned so that the pupils may ask questions. These questions should be answered immediately.

USE TO BE MADE OF RESULTS:

Those making a creditable score, and by so doing prove they understand the principles involved, should proceed with their assigned work.

Those making a poor score should be assembled at a convenient time for special instruction.

To assist these pupils explain the principles of the working drawing using models, drawings, a screen, the blackboard, etc. Have the pupils repeat the test and answer any question that arises.

The second test will require little or no explanation. The purpose of the second test is to give more drill in determining dimensions and to check the effectiveness of instruction given to the slower pupils on the first test.

Testing Your Ability To Determine Correct
Dimensions. (1)

A----- 1

B----- $1 \frac{1}{2}$ C----- $\frac{1}{2}$ D----- $\frac{3}{4}$ E----- $1 \frac{1}{4}$ F----- $1 \frac{3}{4}$ G----- $\frac{3}{4}$ H----- $\frac{7}{8}$ I----- $\frac{3}{4}$ J----- $\frac{1}{2}$ K----- $\frac{3}{8}$ L----- $1 \frac{1}{8}$ M----- $2 \frac{1}{4}$ N----- $\frac{3}{8}$ O----- $\frac{1}{2}$ P----- $\frac{1}{4}$ Q----- $\frac{3}{8}$ R----- $1 \frac{1}{2}$ S----- $\frac{3}{8}$ T----- $\frac{1}{2}$ U----- $\frac{5}{8}$ V----- $1 \frac{5}{8}$ W----- $\frac{1}{2}$ X----- $\frac{5}{8}$

Testing Your Ability To Determine Correct
Dimensions. (2)

A----- 1
B----- $1 \frac{1}{2}$
C----- $\frac{1}{4}$
D----- 3
E----- $\frac{3}{4}$
F----- $\frac{1}{4}$
G----- $\frac{3}{8}$
H----- $1 \frac{1}{2}$
I----- $2 \frac{1}{2}$
J----- 1
K----- $\frac{3}{8}$
L----- 3
M----- $\frac{1}{4}$
N----- $\frac{3}{8}$
O----- $\frac{3}{8}$
P----- $\frac{5}{8}$
Q----- 2
R----- $\frac{1}{2}$
S----- $\frac{3}{4}$
T----- $\frac{1}{4}$
U----- $1 \frac{1}{4}$
V----- 1
W----- 1
X----- $\frac{3}{4}$
Y----- $\frac{5}{8}$

TESTING YOUR ABILITY TO DETERMINE DIMENSIONS

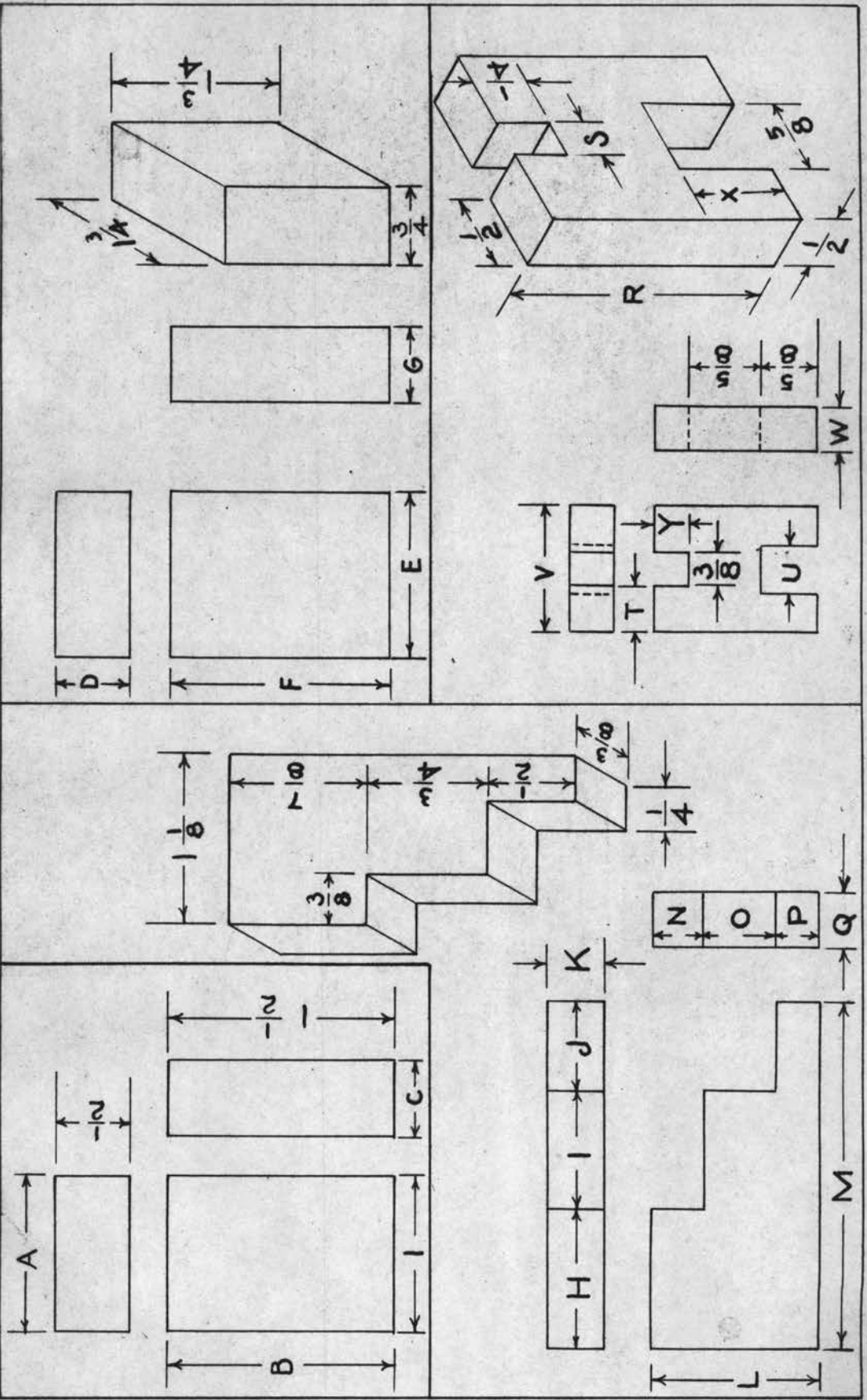

TESTING YOUR ABILITY TO DETERMINE DIMENSIONS

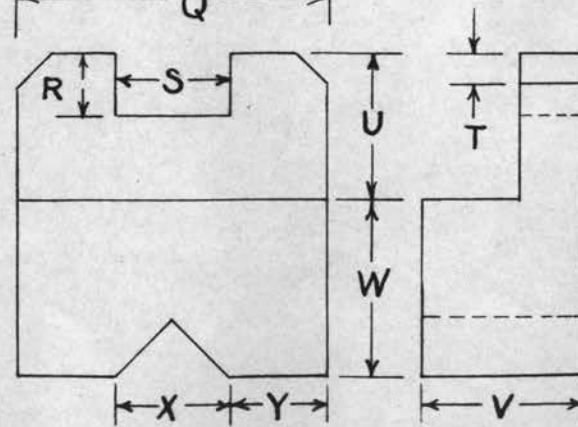
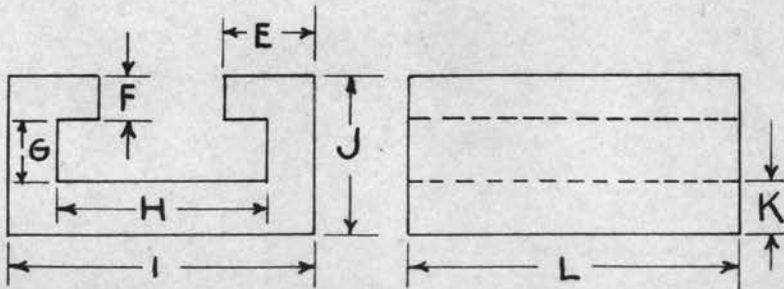
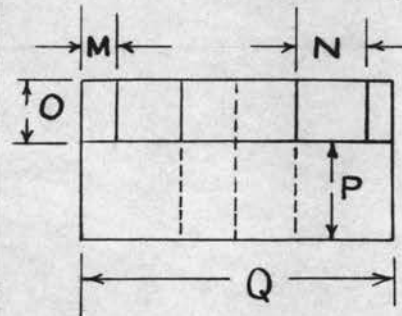
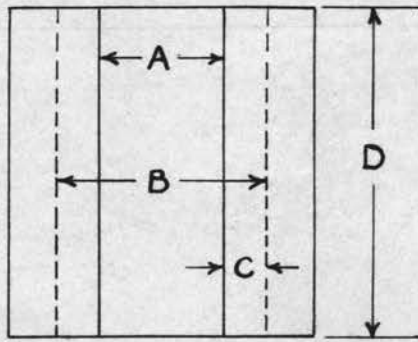
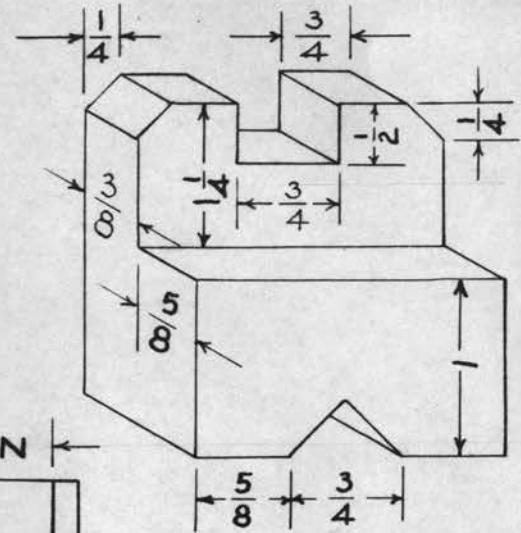
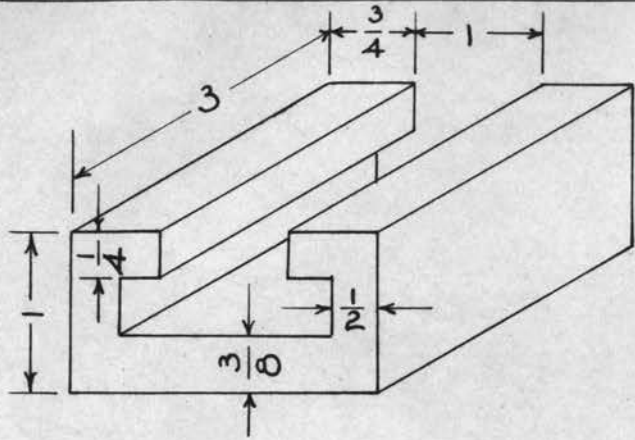

CHAPTER X

Testing Your Ability To Choose And Properly Locate Views
In Orthographic Projection

PURPOSE OF THE TEST:

The purpose of this series of tests is to determine the pupils ability to visualize drawings and to give them drill in this fundamental.

The time allowed the pupil to learn each fundamental idea in mechanical drawing must be ample, for, no matter how simple the problem or how clear the demonstration preceding it, repetition of the experience is necessary to make the element become a usable part of the pupil's knowledge. Repetition of any point may be secured in a variety of ways. Blackboard sketching, lecture, instrumental drawing, freehand drawing, and testing, may be used over and over until the principle or idea is firmly fixed. The emphasis here is that all important details shall be taught definitely, one at a time, with specific attention directed to them, in various problems which provide ample drill. In testing it is best to apply problems to new situations. Using some object in a test the pupil is familiar with sometimes automatically solves the problem for him. If the pupils have never seen the object before they have a more equal opportunity of solving the problem.

AMOUNT AND KIND OF WORK TO BE DONE BEFORE GIVING THE TEST:

The principle of orthographic projection should be fully explained. The pupils should make several freehand sketches from objects and from these sketches make mechanical drawings of the objects. Also, the writer's experience shows that one or two drawings from a text book

should be made before giving the first test.

MATERIALS NECESSARY:

It will be necessary to have an enlarged drawing of the test as shown and for each pupil to have a sheet of paper, a pencil, and an eraser.

INSTRUCTIONS FOR GIVING THE TEST:

After making certain all materials are available, have the pupils fill out the heading (Name, name of test, number of test, date, classification, etc.) on the answer sheet that will best fit local school needs.

Have pupils layout their answer sheets as follows:

A	C
Front---	Front---
Top-----	Top-----
Right---	Right---
B	D
Front---	Front---
Top-----	Top-----
Right---	Right---

By having the answer sheet filled out in the manner shown above many questions will be eliminated and the test will be answered with more uniformity.

The pupils should not ask questions while the test is in progress. They should begin work as soon as possible and continue to do so until they have completed the test. Those who finish should check their papers for errors if time permits.

When all have finished have the pupils exchange their papers for

scoring. Read the answers, have the pupils check all mistakes and write the number wrong at the top of the sheet. Have papers returned so that the pupils may ask questions. These questions should be answered immediately.

USE TO BE MADE OF RESULTS:

Those making a creditable score, and in so doing prove they understand the principles involved, should proceed with their assigned work.

Those making a poor score should be assembled at a convenient time for special instruction. To help these pupils have them draw freehand the front, top, and right side views of the pictorial drawings A, B, C, and D on the test. After they have finished have them repeat the test and answer their questions as they arise.

After the first test has been given very little explanation will be required for the others. Follow the same procedure for each test. The instructor is the best judge when to use the remaining tests. Results secured from these tests show remedial work to be done, they are not, however, used for grading purposes.

Testing Your Ability To Choose And Properly
Locate Views In Orthographic Projection. (1)

A

Front----- 9

Top----- 4

Right side----- 6

B

Front----- 7

Top-----11

Right side-----12

C

Front----- 2

Top----- 1

Right side----- 5

D

Front-----10

Top----- 8

Right side----- 3

Testing Your Ability To Choose And Properly
Locate Views In Orthographic Projection. (2)

A

Front-----12

Top----- 6

Right side----- 3

B

Front----- 4

Top-----11

Right side----- 5

C

Front-----10

Top----- 8

Right side----- 2

D

Front----- 7

Top----- 1

Right side----- 9

Testing Your Ability To Choose And Properly
Locate Views In Orthographic Projection. (3)

A

Front-----12

Top----- 5

Right side----- 3

B

Front----- 9

Top----- 7

Right side----- 4

C

Front----- 6

Top----- 1

Right side----- 11

D

Front-----10

Top----- 2

Right side----- 8

Testing Your Ability To Choose And Properly
Locate Views In Orthographic Projection. (4)

A

Front----- 8

Top----- 4

Right side----- 7

B

Front----- 5

Top----- 6

Right side----- 2

C

Front----- 9

Top-----11

Right side----- 3

D

Front----- 1



Top-----10

Right side-----12

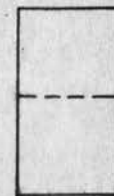
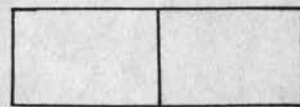
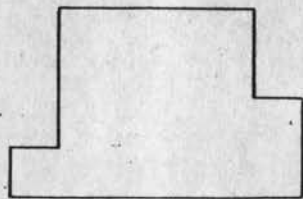
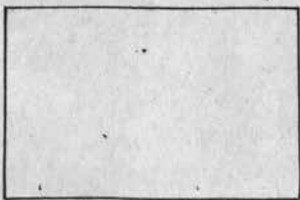
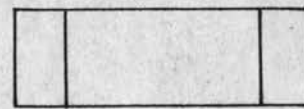
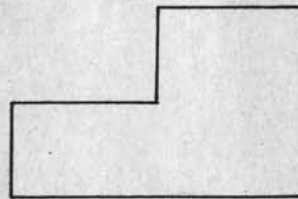
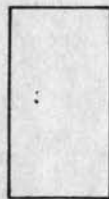
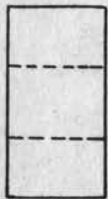
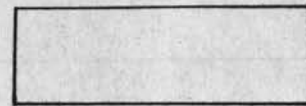
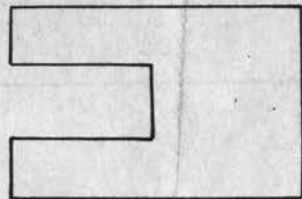
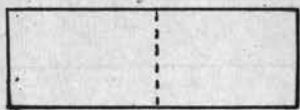
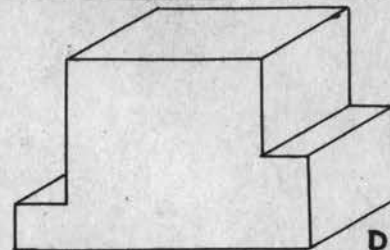
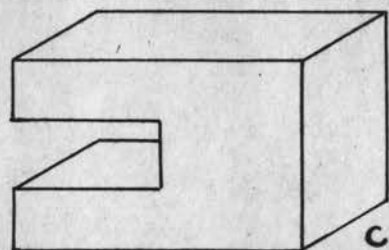
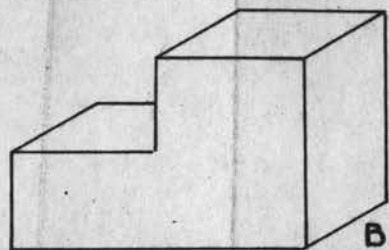
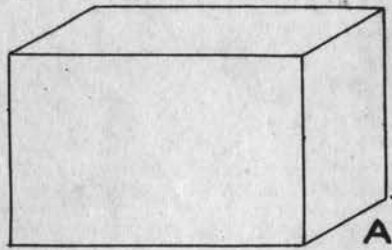
TESTING YOUR ABILITY TO CHOOSE AND PROPERLY LOCATE VIEWS IN ORTHOGRAPHIC PROJECTION (1)

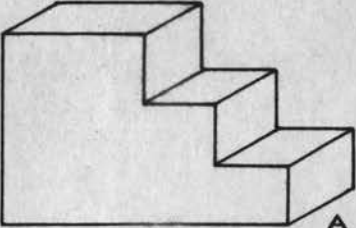
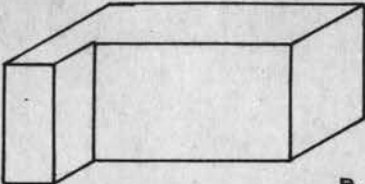
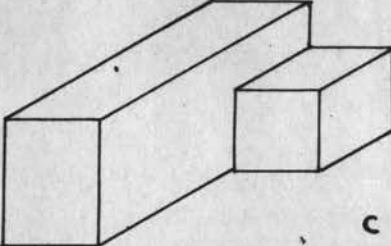
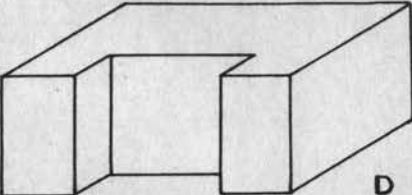
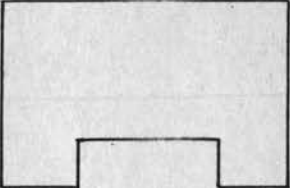
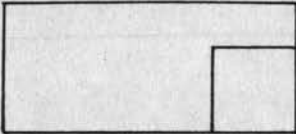
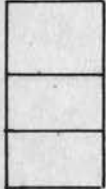
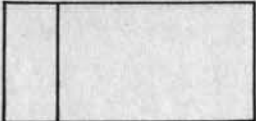
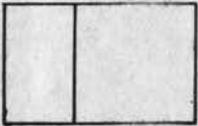
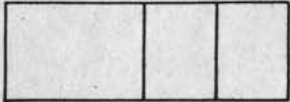

TESTING YOUR ABILITY TO CHOOSE AND PROPERLY LOCATE VIEWS IN ORTHOGRAPHIC PROJECTION (2)

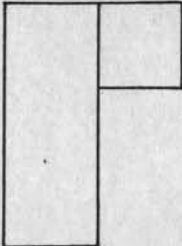
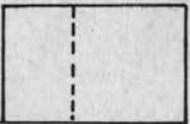
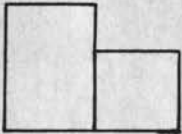
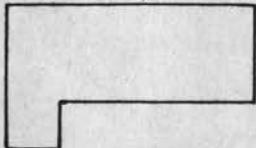
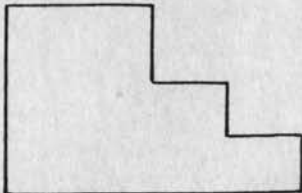
 <p>A</p>	 <p>B</p>	 <p>C</p>	 <p>D</p>
 <p>1</p>	 <p>2</p>	 <p>3</p>	 <p>4</p>
 <p>5</p>	 <p>6</p>	 <p>7</p>	 <p>8</p>
 <p>9</p>	 <p>10</p>	 <p>11</p>	 <p>12</p>

TESTING YOUR ABILITY TO CHOOSE AND PROPERLY LOCATE VIEWS IN ORTHOGRAPHIC PROJECTION (3)

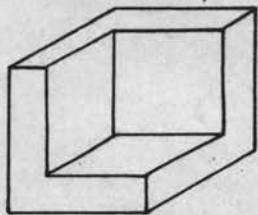

A

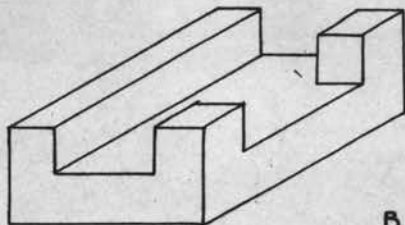

B

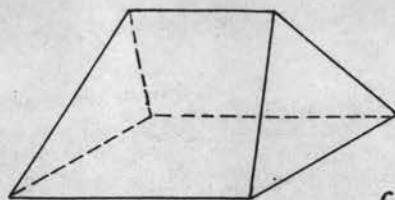

C

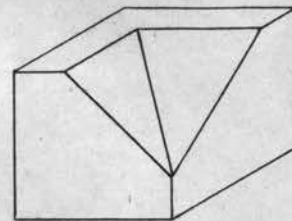

D

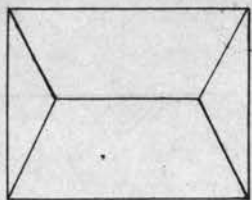

1

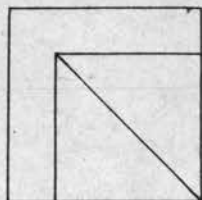

2

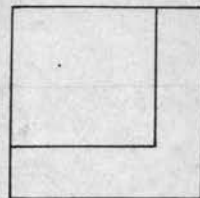

3

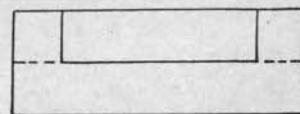

4

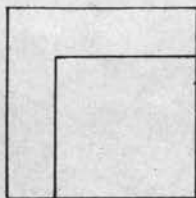

5

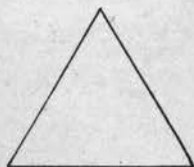

6

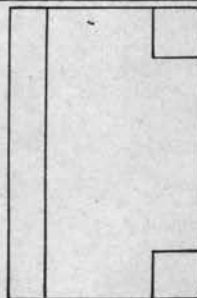

7

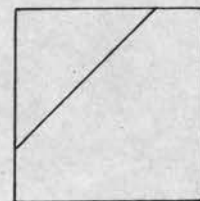

8

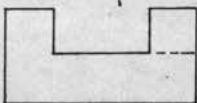

9

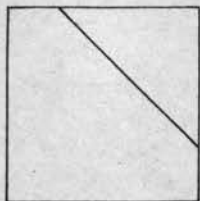

10

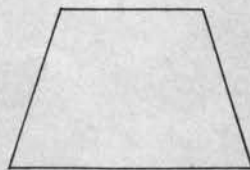

11

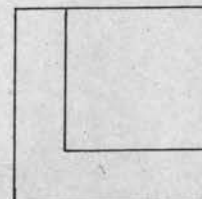

12

TESTING YOUR ABILITY TO CHOOSE AND PROPERLY LOCATE
VIEWS IN ORTHOGRAPHIC PROJECTION (4)

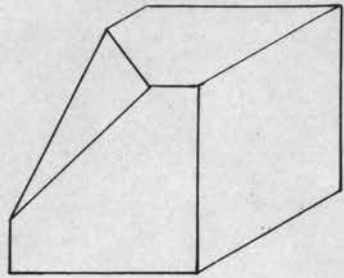

A

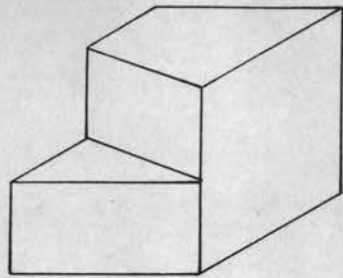

B

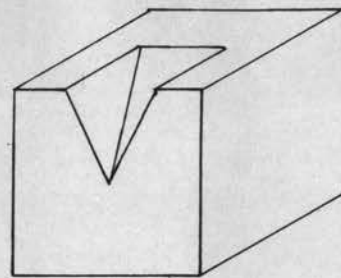

C

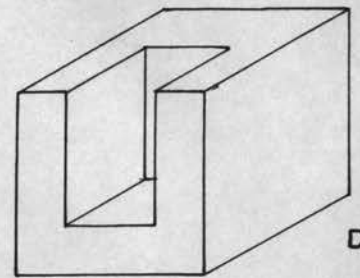

D

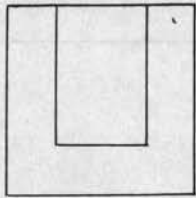

1

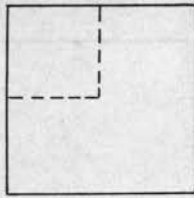

2

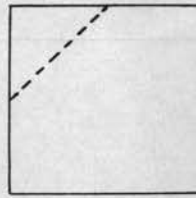

3

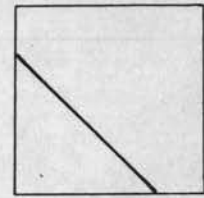

4

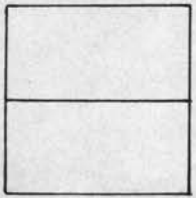

5

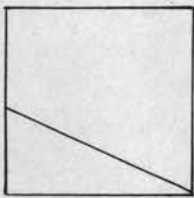

6

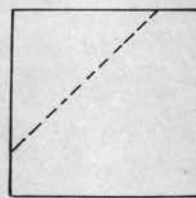

7

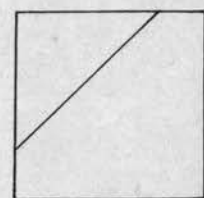

8

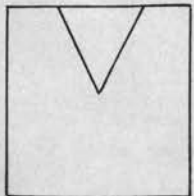

9

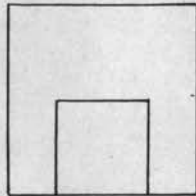

10

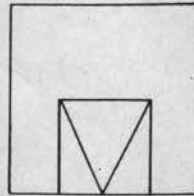

11

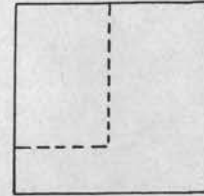

12

CHAPTER XI

FREEHAND SKETCHING

These drawings are made on 22 x 28 inch heavy mat board. On one side of the card is a three view orthographic drawing of an object and on the opposite side is an oblique or cabinet drawing of the same object. Only three problems are shown here but more problems can be made to meet the needs of a class.

PURPOSE OF THE TEST:

It is desirable for the pupils to get more practice in solving orthographic projection problems than is usually obtained in the regular mechanical drawing courses. By using a series of drawings as shown, much work can be covered in a short time. By having the pupils solve the problems freehand at their tables no time is lost, and by using cards prepared in advance the instructor is put to no disadvantage by blackboard sketching. Problems can be worked more rapidly freehand and hence a greater number can be solved. The instruction and training in freehand drawing is highly desirable as a means of clear, accurate, rapid expression.

AMOUNT AND KIND OF WORK TO BE DONE BEFORE GIVING THE TEST:

It is necessary to explain the three view working drawing. A good method to use is sketching on the blackboard from models large enough for the entire class to see. While sketching on the blackboard make all necessary explanations, answer questions, and have the pupils make freehand sketches of all work as it is placed upon the board. Blackboard sketching is also excellent experience for the pupil and if possible all the pupils should have an opportunity to do some

of this work along with their drawing course.

MATERIALS NECESSARY:

It will be necessary to have an enlarged drawing as shown and for each pupil to have a clean sheet of paper, a pencil, and an eraser.

INSTRUCTIONS FOR GIVING THE TEST:

Place one of the drawings before the pupils and have them proceed as previously instructed, drawing the front, top, and right side views. Do not hurry the pupils, but do insist on neatness and accuracy. Insist also upon silence and eliminate as nearly as possible any opportunity to do copy work. Very often a single glance at a correct drawing will answer the entire problem.

USE TO BE MADE OF THE RESULTS:

When all have finished reverse the card so that the correct orthographic views can be seen. This will give the pupil an opportunity to check his own drawing, make his own corrections, and ask questions on points not clear to him. These problems in freehand drawing correspond closely to blackboard work in mathematics.

These same drawings may be used in teaching cabinet drawing. Place the three view working drawing before the pupils and have them sketch a cabinet drawing of the object. It would be well to use isometric drawings as well as cabinet drawings in this type of sketching.

DRAW THE FRONT, TOP, AND
 RIGHT SIDE VIEWS OF THIS OBJECT.
 PLACE THE THREE DIMENSION LINES
 IN THEIR PROPER PLACE.

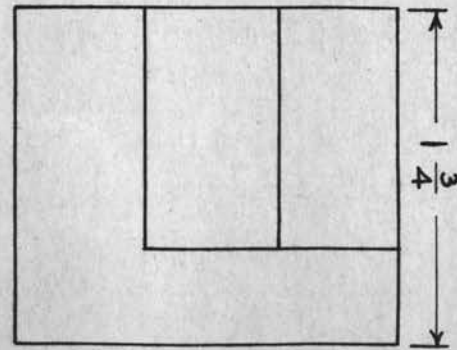
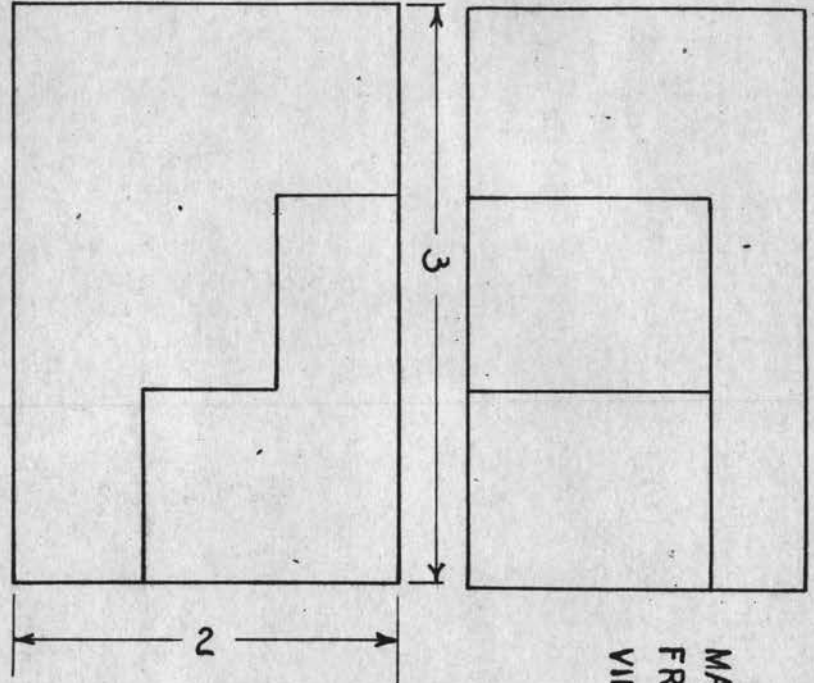
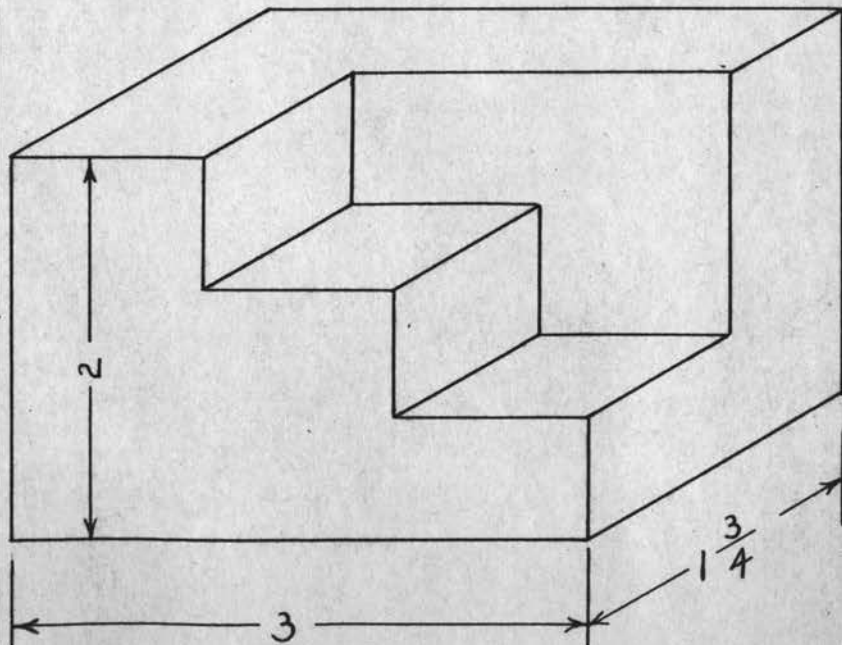

MAKE A CABINET DRAWING
 FROM THE THREE GIVEN
 VIEWS.

DRAW FRONT, TOP, AND RIGHT SIDE VIEWS. PUT IN ALL HIDDEN LINES.

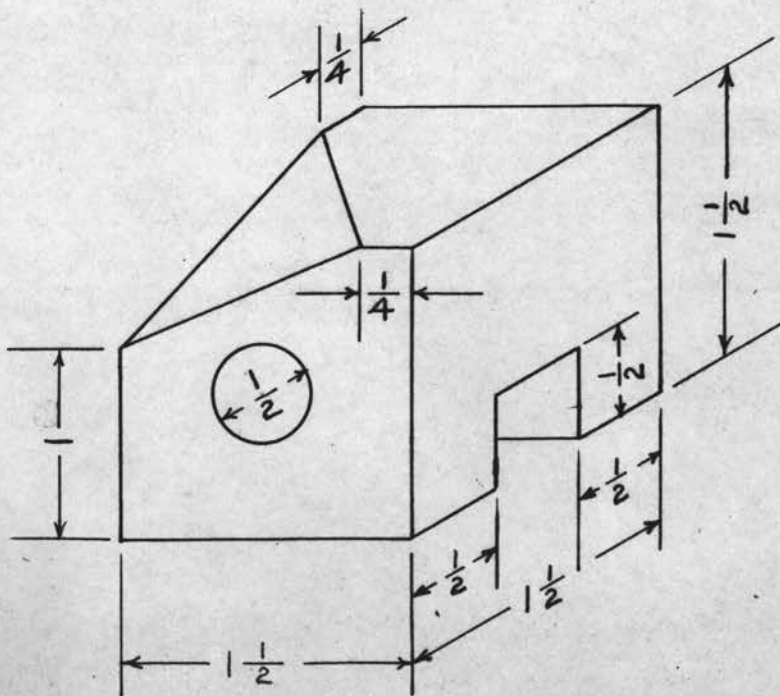

MAKE A CABINET DRAWING FROM THE THREE GIVEN VIEWS.

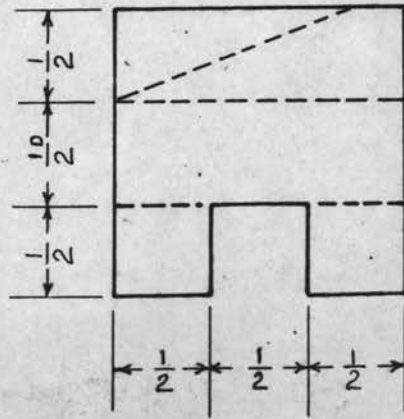
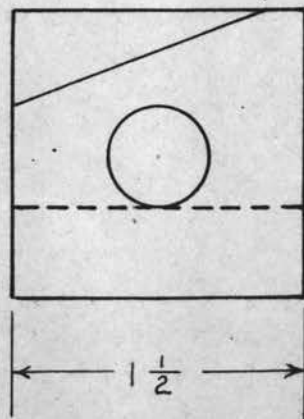
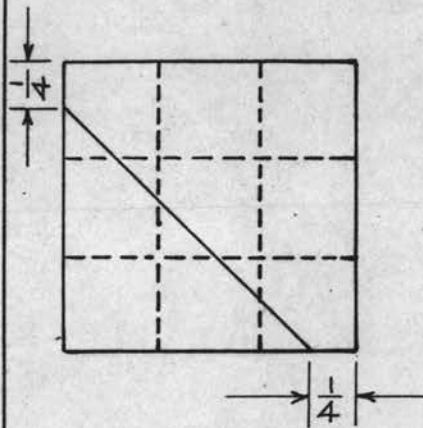

DRAW THE FRONT AND RIGHT SIDE VIEWS. SHOW CUTTING PLANE LINES AND ALL CENTER LINES.

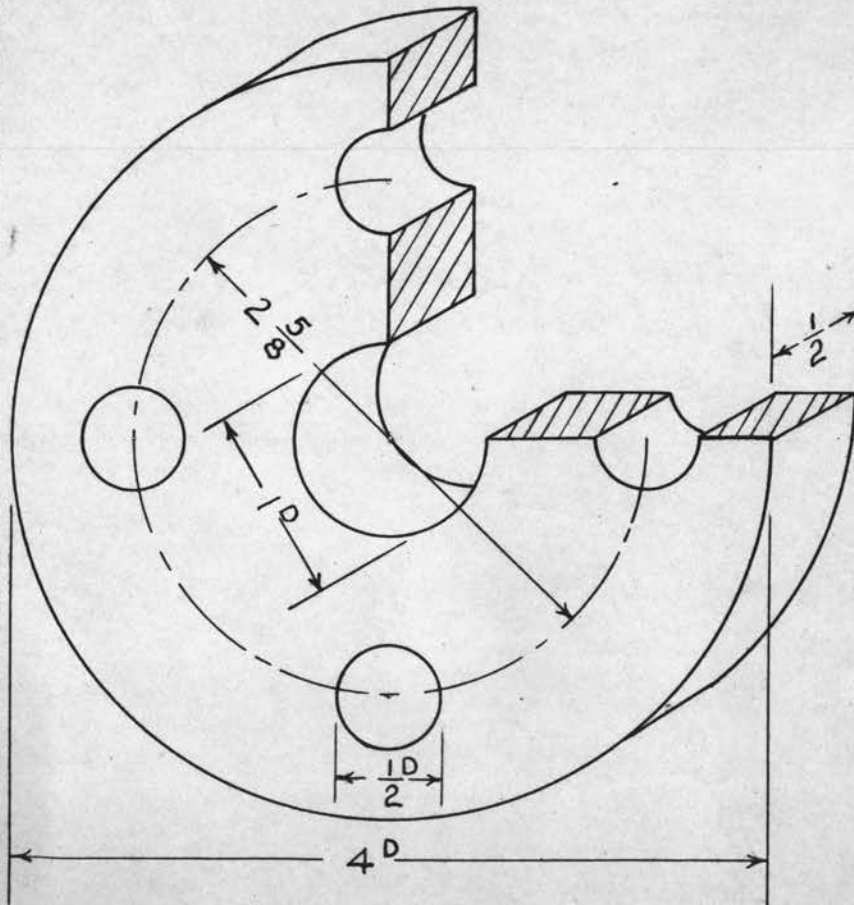

MAKE A CABINET DRAWING FROM THE TWO GIVEN VIEWS

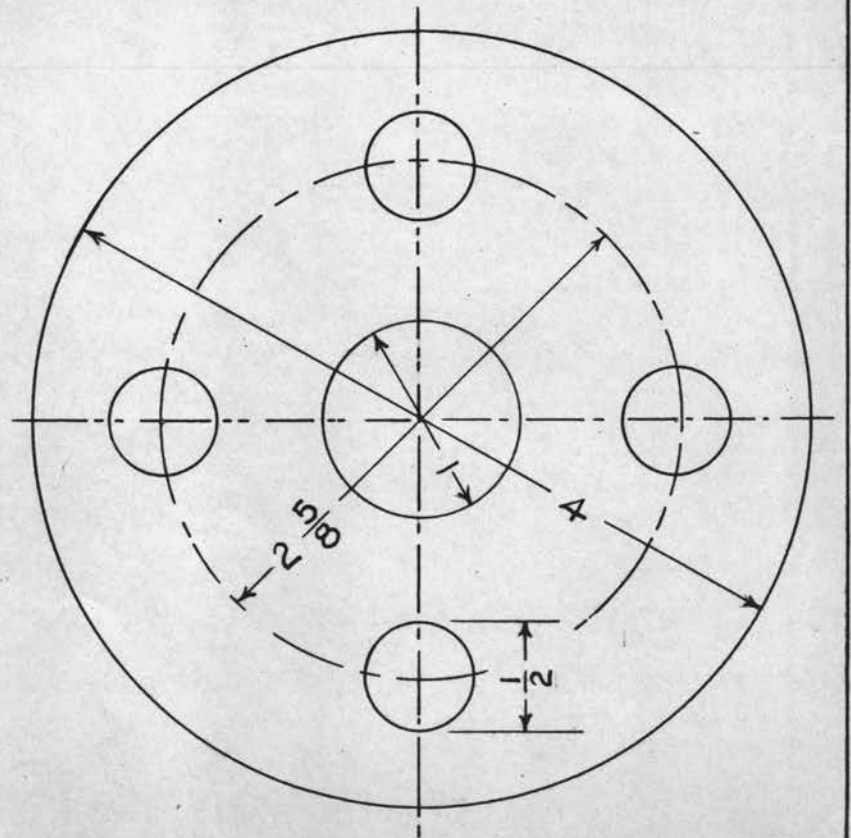
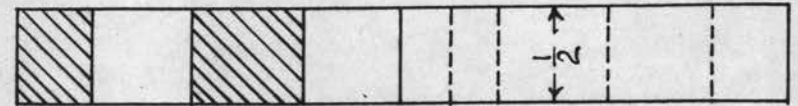

CHAPTER XII

CONCLUSION

For several years the writer used the instructional aids described in this study made up in hectographed form on eight and one half inch by eleven inch sheets of paper. When this form of instruction was used it was necessary to pass out the sheets to each individual. This method consumed too much time and created some confusion both in distributing and collecting the papers. It was also found difficult to file these papers in an orderly manner. By permitting the pupil to handle the sheets it was necessary to replace a few copies in each unit every year.

By enlarging these units as described in the "preface" of this study, many of the undesirable features have been eliminated. Although the charts are large it is not difficult to keep them orderly when not in use. With proper care they should last indefinitely.

Instructors of mechanical drawing often spend many hours after school making drawings on the blackboard to be used for lecture purposes the following day. The use of these enlarged charts will not eliminate all blackboard work but will eliminate much of it. Sometimes drawings made on the spur of the moment are not as accurate as the instructor would have them, whereas, the charts can be accurately drawn with the use of instruments.

In schools where classes are large and the drawing room is used by both beginning and advanced pupils, it is difficult to monopolize the entire blackboard for one day, for one particular group. When such conditions exist the use of prepared charts is very convenient.

In lecture work in mechanical drawing as well as in other subjects it is sometimes difficult to present all the details previously prepared in a lecture outline. By using a premeditated drawing that has been thoughtfully and intelligently prepared and following definite instructions in its presentation this difficulty is to some extent eliminated. It is also possible to systematically organize these units so they may be properly timed in advance.

The original cost is the only cost of this type of instruction as the answer sheets are made by the pupils. As the need arises other instructional units can be added.

In the bibliography to this thesis, a list of references has been given which could be of much practical value for those interested in making additions to these instructional units. No attempt has been made here to give tests for the sake of testing or for determining a grade or score in mechanical drawing. Reasoning in mechanical drawing is what is required today; and as this fact is realized, mechanical drawing will be taught more and more as here given.

BIBLIOGRAPHY OF
MECHANICAL DRAWING REFERENCES
ADAPTED TO THIS STUDY

- Abercrombie, T. R.: "Grading in Drawing Courses," Indus. Arts.Mag., March, 1928, p. 90.
- Abercrombie, T. R.: "A Basis for Grading Drawing Problems," Indus. Ed. Mag., Vol. 29, April, 1928; p. 332.
- American Standards Association, Drawings and Drafting Room Practice, The American Society of Mechanical Engineers, 29 West 39th, Street, New York, N. Y.
- American Vocational Association, Standards of Attainment in Industrial Arts Teaching, L. H. Dennis, Secretary A. V. A., Washington, D. C.
- Barnes, R. H.: "A Basis for Evaluating the Work of Mechanical Drawing Students," Indus. Ed. Mag., Aug. 1923, p. 52
- Bartholomew, Roy A. and Orr, F. S.: "Learning to Read Mechanical Drawings," The Manual Arts Press, Peoria, Ill., 1937.
- Bedker, R. R.: "Flash Cards for Mechanical Drawing Classes," Indus. Arts.Mag., (Feb. 1937), 62.
- Bright, Jonathan: "Freehand, Third-Angle Projection for Beginners in Mechanical Drawing," Indus. Arts Mag., (Nov 1932), 330.
- Castle, D. W.: "Mechanical Drawing Tests," Voc. Ed. Mag., (May 1924), 756.
- Castle, Drew W. and Selvidge, R. W.: "Problems in Blueprint Reading," The Manual Arts Press, Peoria, Ill., 1926.
- Duvelius, A. W.: "Measuring Mechanical Drawing Skill," Indus. Ed. Mag. (July 1927), 16.
- Ermeling, W. W.: "Some Standards by which to Judge Mechanical Drawing Tests," Ind. Arts Mag., XI (1922), 427.
- Faber, I. R., and Kellogg, D. C.: "Standardizing the Rating of Mechanical Drawings," Indus. Arts Mag., (Oct. 1924), 390.
- Fischer, F. A. P.: "Development and Analysis of a Series of Mechanical Drawing Tests," Indus. Ed. Mag., XXI (May 1931), 168-170.
- Flam, August: "Objective Tests in Mechanical Drawing," Indus. Ed. Mag., (Dec. 1926), 201.
- Flam, August: "First Year Mechanical Drawing Multiple Choice Test.,"

- Indus. Arts Mag., (Feb. 1928), 70, (Mar. 1928), 107.
- Flam, August; "First Year Mechanical Drawing Test," Indus. Arts Mag., (June 1928) 223, (Sept. 1928), 336.
- Flam, August: "Second Year Mechanical Drawing Test.," Indus. Arts Mag., (Oct., 1928) 371.
- Flam, August: "Some Mechanical Drawing Tests," Indus. Arts Mag., (April, 1930) 150-151.
- Hoelscher, Randolph P., "The Teaching of Mechanical Drawing," John Wiley and Sons, Inc., New York, 1929.
- Horning, S. D.: "Tests of Prognostic Value in Mechanical Drawing," Indus. Ed. Mag., (June, 1928) 441.
- Hunter, W. L. "Two Drawing Tests," Ind. Ed. Mag., XXVII (1926) 410-11
- Johnson, V. A.: "Teaching Devices in Mechanical Drawing," Ind. Arts Mag., XXVI, (Feb. 1937), 49.
- Kepler, F. R.: "A Survey of Drafting Room Practices," Ind. Arts Mag., Vol. XXV (March, 1926), 377.
- Kline, M. R.: "A Mechanical Drawing Test," Ind. Arts Mag., XXI (May, 1931), 174.
- Knoll, Harry W.: "Drawing Test," Ind. Arts Mag., (April, 1930) 143-7
- Morris, J. Allen: "An Individualized Flexible Speller," Ind. Arts Mag., XXVI (Feb., 1937), 44.
- Nash, Harry B. and Van Duzee, Roy R.: "Instructional Review Tests in Mechanical Drawing," The Bruce Publishing Co., Chicago, Ill., 1930.
- Olsen, J. K. "Mechanical Drawing," Indus. Arts Mag., XXVI (Feb., 1937), 53.
- Radford, S. S.: "Accuracy in Mechanical Drawing," Ind. Arts Mag., XXVI (Sept., 1937), 276.
- Radford, S. S.: "Accuracy in Mechanical Drawing," Ind. Arts Mag., XXV (Dec., 1936), 377.
- Sack, H. J.: "Mechanical Drawing in a Southern High School," Ind. Arts Mag., (Mar., 1938), 97.
- Veigel, A. M.: "Methods and Aids in Teaching Mechanical Drawing to the Beginning Pupil," Ind. Ed. Mag., XXXVII, (May, 1935), 163.

Typed By:

Marvin D. Livingood
and
Juanita Fugate