

Date: March 10th, 2022

To: American Institute of Chemical Engineers (AIChE) and Global Petrochemicals

From: Design Team 7 – Riley Dunham, Jacob Knepler, Adam McBride, & Hylton Purdum

Subject: Closing Critical Gaps to Enable a Circular Plastics Economy

To whom it may concern:

Within the attached report, you will find the preliminary design for the pyrolysis oil purification unit in Singapore and the improvement recommendations for the waste sorting facility in Bali, Indonesia.

The preliminary design includes a computer simulation for the fractionation of the PyOil into valuable products; PyGas, naphtha (Light cut), gas oil (Medium cut), barge oil, and coking material. The design contains a process description encompassing PFDs and P&IDs of the proposed design, economic costing, and overall process safety analysis.

The sorting facility recommendations outline steps to close the quality, quantity, and affordability gaps posed at the Bali sorting facility.

Please request any additional information necessary for your decision.

Best Regards.

Closing Critical Gaps to Enable a Circular Plastics Economy

AICHE Design Competition 2022-2023

Members: Riley Dunham, Jacob Knepler, Adam McBride, & Hylton Purdum

Assigned Date: 1/17/22

Due Date: 3/10/22

Executive Summary:

Global Petrochemicals and AIChE requested the design, optimization, and economic evaluation of a PyOil purification plant and recommendations for improvement of a sorting facility in Bali as well as recommendations to increase participation in waste management in the region.

The design of the PyOil purification plant had two major sections: A fractionation section of the plant where PyOil feed would be split into PyGas, a Light Cut, a Medium Cut, Barge Oil, and potential coking products; and a purification section of the plant where the Light Cut and Medium Cut would have contaminants removed. The Light Cut and Medium Cut products will be utilized as feed for a steam cracker in an ethylene plant, the PyGas as fuel gas in the ethylene plant, and the Heavy Cut split into two products for the sake of creating new profitability for the process. The plant was designed to operate continuously and was designed with spare equipment so that production upsets would not stop production of products or cause off specification production. Overall, the design was evaluated to cost \$19.6 million in capital cost, \$1.99 million per year in variable cost, and \$4.35 million per year in fixed cost.

When looking at how to improve the sorting facility and community involvement, three critical gaps were sought to be closed with possible new solutions which would also take steps toward solving the plastic waste issue. It was sought to close gaps in Quality, Quantity, and Affordability with recyclable waste collection process in Bali. To solve the quality gap, a three-bag system would be introduced to shift sorting responsibility from the waste collection company to the households. With an increase in the quality of waste sorting, the quantity gap would close as a greater separation of waste entering the waste facilities would also mean that the facility would be capable of greater throughput of recycled products. The quantity gap would also be closed with a cooperative program to encourage households to recycle more often because of an incentive system that would compensate participating households at the end of every year. Both the quality and quantity gap solutions would help close the affordability gap by minimizing cost for waste management facilities in Bali with a lower labor cost per waste delivered.

Table of Contents:

Executive Summary	2
Table of Contents	3
Table of Figures & Tables	4
Introduction	5
Brief Process Description	6
Process Details	8
- Distillation Process Flow Diagram	8
- Adsorption & Storage Process Flow Diagram	9
- Stream Summary Table	10
- Equipment Summary Table	11
- Utility Summary Table	12
Economics of Process	13
- Capital Cost Estimate	13
- Variable Cost Estimate	13
- Fixed Cost Estimate	16
Process Safety	17
- Minimizing Environmental Impacts	17
- Piping and Instrumentation Diagram (P&ID)	18
- Pressure Relief Valve Sizing	19
- Failure Rate Analysis	20
- Personnel Exposure Risk	21
- Atmospheric Detonation of Distillation Inventory	22
- Hazard and Operability Study (HAZOP)	24
Recommendations for Improvement of the Bali Sorting Facility	27
- Introduction to Cold Eyes Review	27
- Recommendations for Closing the Quality Gap	28
- Recommendations for Closing the Quantity Gap	29
- Recommendations for Closing the Affordability Gap	30
- Conclusion to Cold Eyes Review	31
Conclusions	32
Appendix 1 - Adsorption Section Detail	33
Appendix 2 - Distillation Section Detail	37
References	46

Table of Figures & Tables:

Figure 1: Block Flow Diagram of PyOil Purification	6
Figure 2: Block Flow Diagram Consideration	7
Figure 3: Distillation Process Flow Diagram	8
Figure 4: Adsorption & Storage Process Flow Diagram	9
Figure 5: Tornado Chart	14
Figure 6: Piping and Instrumentation Diagram for Light Cut Tower (T-102)	18
Figure 7: Conventional Relief Valve	19
Figure 8: Failure Rate Analysis by Process Progression	20
Figure 9: NFPA Summary & Chemical Compatibility Chart	21
Figure 10: Equivalency Blast Map	23
Figure 11: Map of Bali & Areas of Focus	27
Figure 12: Examples of a Cyclone Separator	29
Figure 13: Current and Proposed Block Flow Diagrams for Sorting Process	31
Figure 14: Pyrolysis unit in Niigata, Japan	36
Figure 15: Number of Stages vs. N*RR for Medium Cut Tower (T-103)	40
Figure 16: Temperature Profile for T-101	43
Figure 17: Vapor Flow Traffic Profile for T-101	43
Figure 18: Liquid Flow Traffic Profile for T-101	43
Figure 19: Temperature Profile for T-102	44
Figure 20: Vapor Flow Traffic Profile for T-102	44
Figure 21: Liquid Flow Traffic Profile for T-102	44
Figure 22: Temperature Profile for T-103	45
Figure 23: Vapor Flow Traffic Profile for T-103	45
Figure 24: Liquid Flow Traffic Profile for T-103	45
Table 1: Stream Summary Table	10
Table 2: Equipment Summary Table	11
Table 3: Utility Summary Table	13
Table 4: Utility Cost Rate Summary Table	14
Table 5: Equipment Cost Summary Table	15
Table 6: Fixed Cost Summary Table	16
Table 7: Toxic Concentration of Process Chemicals	16
Table 8: TNT Detonation Equivalency	23
Table 9: HAZOP Study for a Distillation Tower	24

Introduction:

Although recycling has been implemented in most developed countries for the past couple of decades, it has mainly been utilized on high value recycling materials like glass and metals. Plastics represents one of the largest areas in which recycling has not been fully realized, with only around 19.5% of plastic getting recycled globally [1]. A staggering 460 million tonnes of plastic are created annually, and that value has increased substantially over the last few decades. There is a large opportunity to recover the ever-increasing amount of plastic waste since it could be used to create fuel sources or other high-value products, but currently, this opportunity is not realized since it is not considered economically viable.

One of the more profitable ways that waste plastic's value can be redeemed is through pyrolysis. Pyrolysis involves the degradation of a feed at high temperatures with the absence of oxygen. The product of plastic pyrolysis is an oil called PyOil which can be fractionated into simpler and more useful mixtures in the same way that crude oil is fractionated. The mixtures, also known as cuts, are used as various fuel sources and are far more valuable when sold individually after separation and decontamination.

A key component yet one of the most expensive challenges facing this process is removing contamination. There is significant contamination whether the recyclables are received properly, salvaged from a land fill, or found discarded in the environment. While some of this contamination can be washed off prior to mechanical or physical recycling, not all the contaminants can be removed. The mixed feed of plastics and other recyclable materials also adds to contamination particularly with PVC or small amounts of metal that are not sorted out before pyrolysis. The chlorine from PVC could form hydrogen chloride when thermally degraded in pyrolysis, which would corrode equipment. The hydrogen chloride could also form ammonium chloride with nitrogen in the mixture, which could potentially cause blockages, an important concern for heat exchangers or the trays of the distillation towers. The metal contaminants cause a variety of problems including fouling, corrosion, potential environmental hazards, and possible burning problems. Both the halogens and heavy metals must be removed before using different fractions of PyOil as fuel and this can be done through adsorption. Adsorption columns purify streams with adsorbents that remove specific substances which they have an affinity for. These substances bond to the adsorbents until the adsorbents can no longer bind enough contaminants to meet product specifications. The adsorbents are then either replaced (when regeneration is not possible) or they are regenerated with an inert gas at high temperatures.

While plastic pyrolysis, separation, and purification are theoretically profitable and would offer a good solution to close the gap in recycling plastic materials, it requires a very large amount of feedstock to be done at a profitable scale. One region which has potential to provide a large number of plastics for pyrolysis is Bali, Indonesia. Bali is an Indonesian island that has very little participation in recycling and waste collection services since these services are optional and must be paid for out of pocket. It is estimated that around 52% of waste is mismanaged (burned, buried, or illegally dumped) leading to over 33 thousand tons of plastic

waste leaking into Bali's surroundings each year [2]. This problem will only become more and more severe over time, but it presents a unique opportunity to provide adequate feedstock for plastic pyrolysis while cleaning up and maintaining the environment.

Brief Process Description:

Global Petrochemicals requested the design, optimization, and economic evaluation of a PyOil purification unit which required separation of PyOil through distillation and decontamination of the Light and Medium cuts through adsorption [3]. The PyOil was derived from pyrolysis of plastic waste offsite, and it will vary in composition based on what plastic waste was used, how thoroughly it was sorted, and how much dirt or other foreign material was left on the plastic. The 4 required splits of the PyOil from lightest to heaviest components are: PyGas, naphtha (Light cut), gas oil (Medium cut), and the Heavy cut. The PyGas will be fed directly to the ethylene plant to be used as fuel gas and the Light and Medium cuts will be used as steam cracker feed.

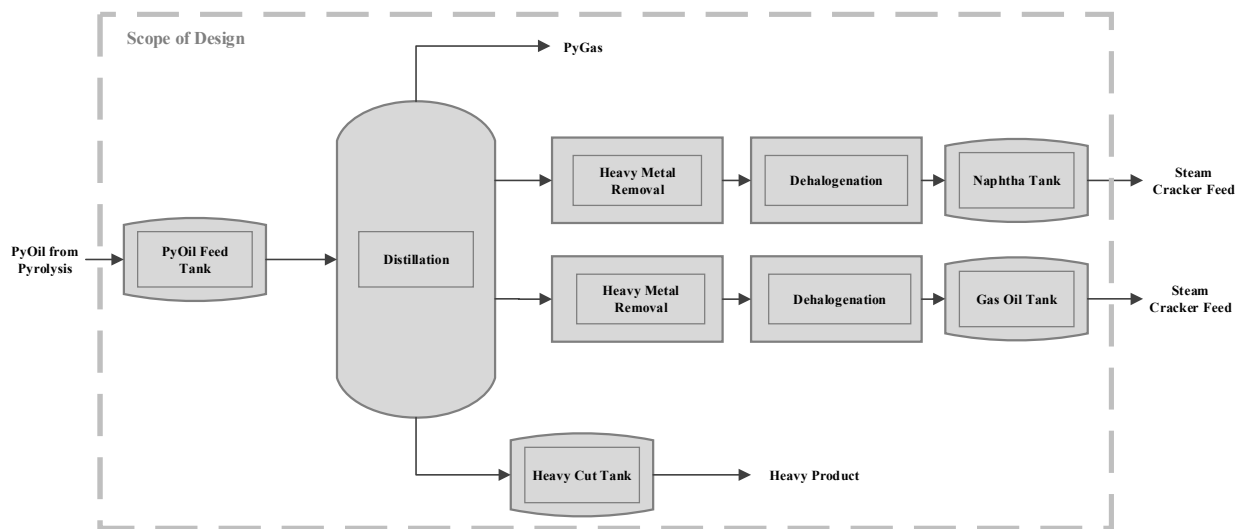

Figure 1: Block Flow Diagram of PyOil Purification

When theorizing how to design the process, two broad design configurations were considered. The first design begins with distillation of PyOil, which would split the PyOil into 4 different product streams. The Light and Medium cuts would be treated separately for contaminants, and the Heavy stream would need to be modified to be desired (either being separated further or by removing large amounts of contaminants). This approach would double the amount of equipment used for the adsorption processes which would increase the frequency of required maintenance and would cost more than treating both streams at the same time (due to the economics of scale).

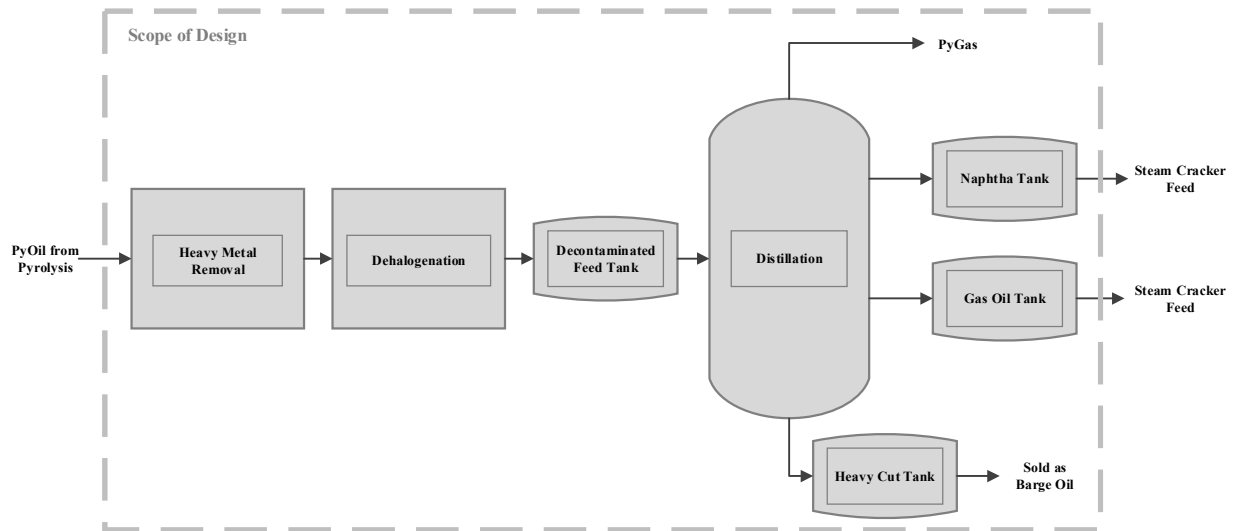

Figure 2: Block Flow Diagram Consideration

The second proposed design begins with the adsorption processes that would remove heavy metals and halogens from the PyOil. The treated PyOil would then be separated and stored before being sold. While this process is less traditional than beginning with separation, in theory the process could be both cheaper to build and operate if no other problems were created with this design. This approach would maximize the economic benefits of scale but would not be treating each stream for its specific level of contamination. For example, the majority of the heavy metal contaminants would be found in the Heavy cut, so pretreatment of the feed wouldn't get every cut to purity specifications unless the process was oversized significantly and could ensure that almost all contaminants were removed. In addition, the requested design required the Light and Medium cut to be decontaminated separately. Both of these factors lead to the decision to follow the first approach, and preliminary design followed that framework.

Additionally, it was requested that a solution be evaluated as to provide the Heavy cut with some method of disposition. The solution that the group designed added economic value to the Heavy cut to aid in the overall economic viability of the process. The Heavy cut was put through a heat exchanger following distillation to further heat it up before entering a flash drum which split the stream into barge oil and untreated coking material. Both products would be sold after the split, but the barge oil would not need to be altered before use and the untreated coking material would need to be altered before being suitable as coking material. Unfortunately, the design and implementation of a coking process is outside of the scope of this project and the sale of the untreated coking material is assumed to be profitable enough.

Pumps and heat exchangers are used liberally to ensure proper process conditions and movement around the facility. All products except the PyGas are stored in one-week tanks which would aid in having a consistent product despite the range of compositions seen in the PyOil (due to the nature of the feed to the pyrolysis unit).

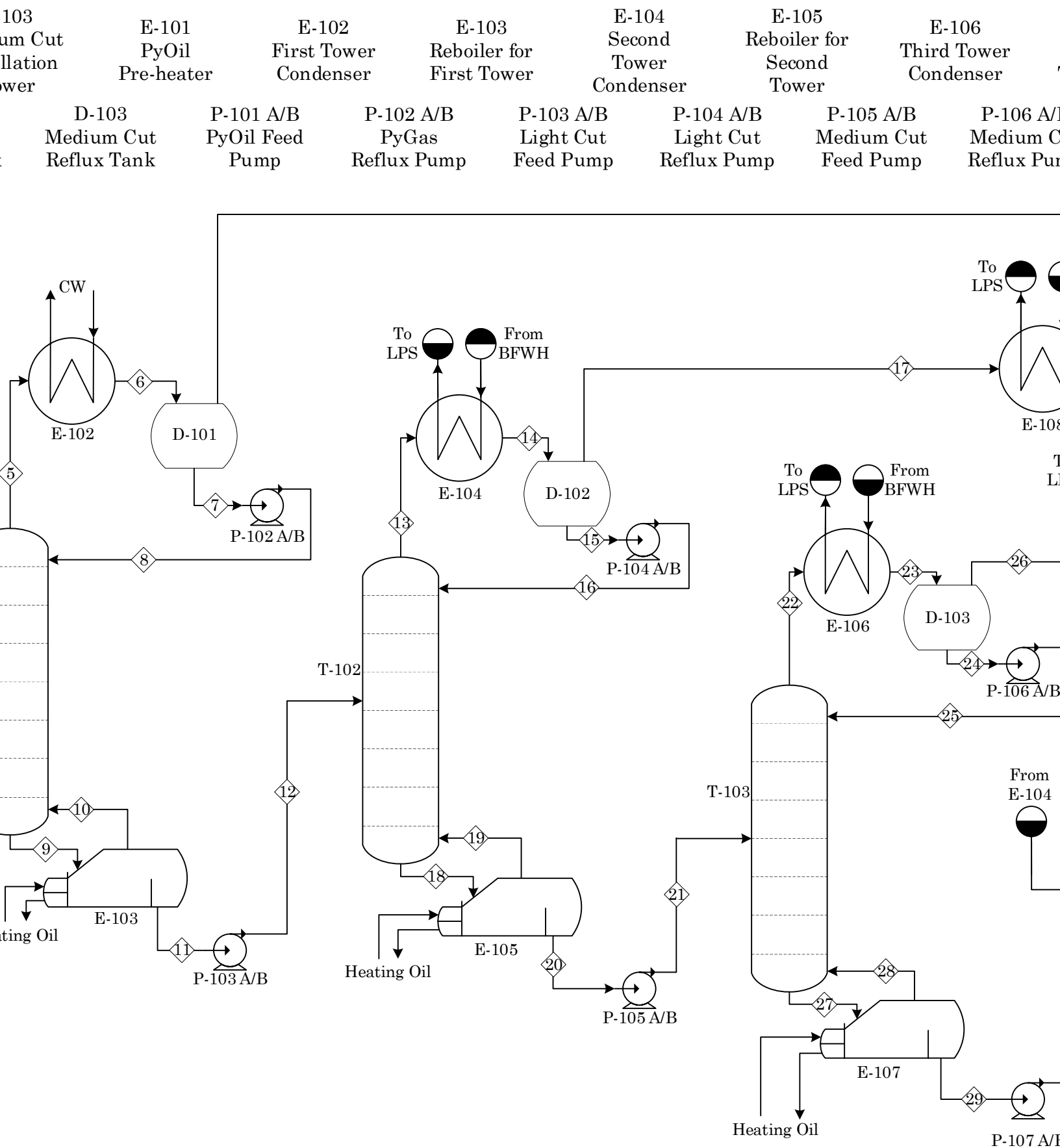

Figure 3: Distillation Process Flow Diagram

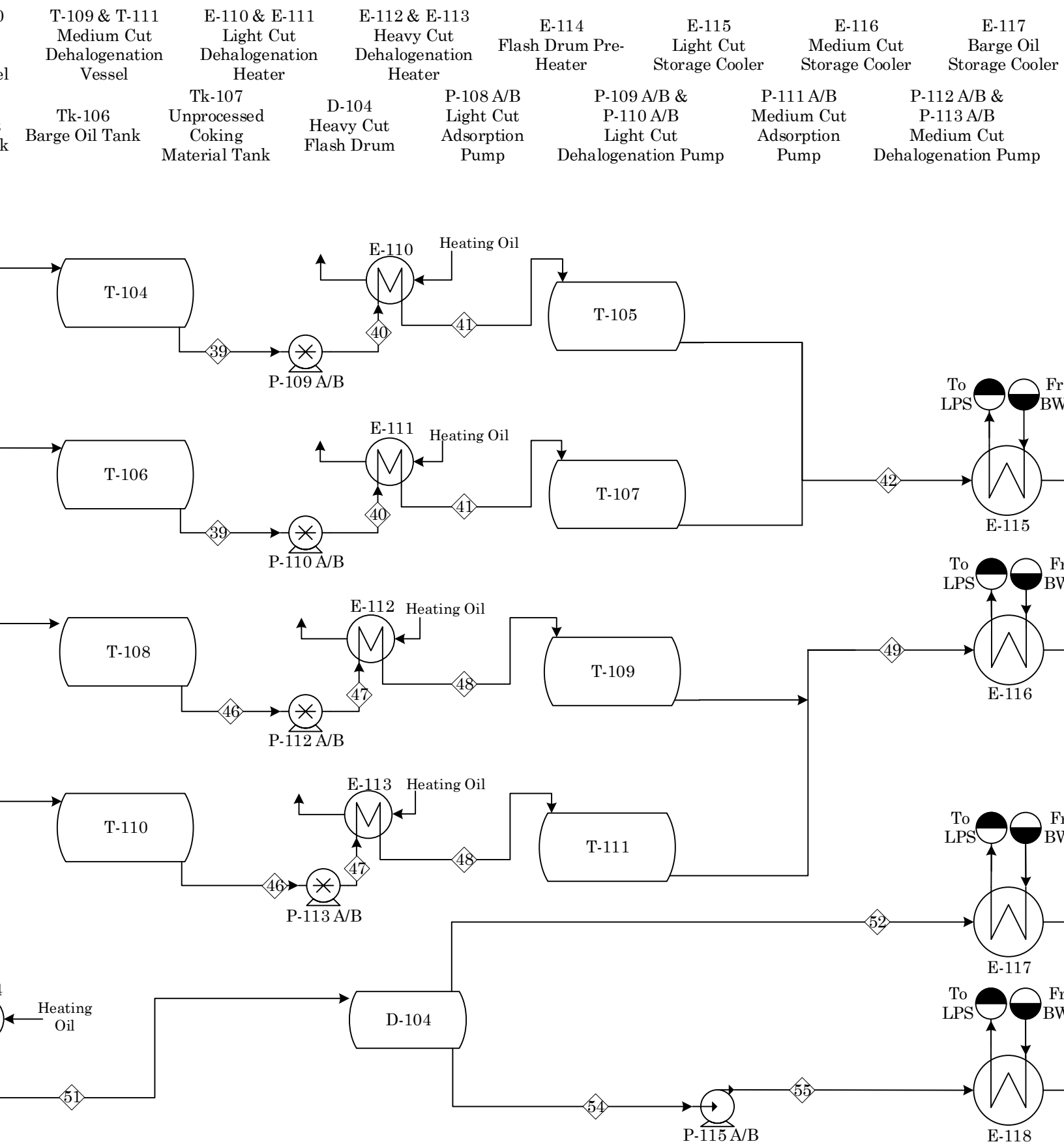

Figure 4: Adsorption & Storage Process Flow Diagram

Table 1: Stream Summary Table

Stream 3	Stream 4	Stream 5	Stream 6	Stream 7	Stream 8	Stream 9	Stream 10	Stream 11	Stream 12
P-101 A/B	E-101	T-101	E-102	D-101	P-102 A/B	T-101	E-103	E-103	P-103 A/B
E-101	T-101	E-102	D-101	P-102 A/B	T-101	E-103	T-101	P-103 A/B	T-102
100	192.5	163.4	107.0	107.0	107.0	341.6	423.6	423.6	423.6
14.00	20.00	19.10	17.10	17.10	19.10	19.17	22.17	22.17	22.17
0.00	0.00	1.00	0.9438	0.00	0.00	0.00	1.00	0.00	0.00
8.03	45.56	0.1608	0.1679	43.58	43.58	40.44	0.3322	39.15	39.15
911.5	-864.3	-419.0	-458.6	-890.2	-890.2	-785.4	-622.6	-729.9	-729.9
82.0	182.0	55.08	55.08	104.7	104.7	165.4	134.0	188.8	188.8
52430	52430	841.9	841.9	89.97	89.97	79040	27360	51680	51680
Stream 19	Stream 20	Stream 21	Stream 22	Stream 23	Stream 24	Stream 25	Stream 26	Stream 27	Stream 28
E-105	E-105	P-105 A/B	T-103	E-106	D-103	P-106 A/B	D-103	T-103	E-107
T-102	P-105 A/B	T-103	E-106	D-103	P-106 A/B	T-103	E-109	E-107	T-103
532.5	532.5	532.5	510.5	488.4	488.4	488.4	488.4	594.5	627.7
21.35	21.35	57.80	17.20	15.2	15.2	17.2	15.2	18.00	21.00
0.00	0.00	0.00	1.00	0.6086	0.00	0.00	1.00	0.00	1.00
0.4097	37.46	37.46	0.3457	0.5073	37.96	37.96	0.3017	36.69	0.4842
555.3	-652.8	-652.8	-568.7	-624.1	-685.1	-685.1	-582.0	-606.7	-493.7
89.6	225.5	225.5	195.5	195.5	204.1	204.1	190.0	254.0	246.2
8650	33930	33930	26350	26350	10760	10760	15590	48470	30130
Stream 35	Stream 36	Stream 37	Stream 38	Stream 39	Stream 40	Stream 41	Stream 42	Stream 43	Stream 44
E-104, E-106, E-108, E-109	Untreated Light Cut	Tk-102	P-108 A/B	T-104, T-106	P-109 A/B, P-110 A/B	E-110, E-111	T-105, T-106	Untreated Medium Cut	Tk-103
Low Pressure Steam	Tk-102	P-108 A/B	T-104, T-106	P-109 A/B, P-110 A/B	E-110, E-111	T-105, T-107	E-115	Tk-103	P-111 A/B
98	180	180	180	180	180	392	392	180	180
4.7	14.7	14.7	14.7	391	338	338	293.9	14.7	14.7
0.00	0.00	0.00	0.00	0.00	0.00	0.00	0.00	0.00	0.00
0.1475	44.14	44.14	44.14	44.14	44.28	37.96	37.91	46.30	46.30
5678	-883.3	-883.3	-883.3	-883.3	-882.3	-754.4	-754.5	-876.6	-876.6
8.02	144.1	144.1	144.1	144.1	144.1	144.1	144.1	190.0	190.0
2252	17750	17750	17750	17750	17750	17750	17750	15590	15590
Stream 51	Stream 52	Stream 53	Stream 54	Stream 55	Stream 56	Stream 57	Stream 58	Stream 59	Stream 60
E-114	D-104	E-117	D-104	P-115 A/B	E-115	E-116	P-114 A/B	E-118	Boiler Feed Water H
D-104	E-117	P-114 A/B	P-115 A/B	E-118	Tk-104	Tk-105	Tk-106	Tk-107	E-115, E-117, E-118
661.6	660.6	100	661.6	661.6	100	100	100	100	80
21.00	15.20	15.20	21.00	45.2	14.7	14.7	14.7	14.7	64.7
0.75	1.00	0.00	0.00	0.00	0.00	0.00	0.00	0.00	0.00
0.6780	0.3496	50.63	35.99	35.99	46.33	48.40	50.63	51.47	62.81
493.9	-470.6	-909.7	-556.0	-556.0	-924.5	-917.0	-909.7	-908.6	-6827
267.9	259.7	259.7	292.5	292.5	144.1	190.0	259.7	292.5	18.02
8340	13330	13330	5005	5005	17750	15590	13330	5005	26848

Table 2: Equipment Summary Table (Heat Exchangers)

E-102	E-103	E-104	E-105	E-106	E-107
Fixed Tube	Kettle Reboiler	Fixed Tube	Kettle Reboiler	Fixed Tube	Kettle Reboiler
	103	19.1	105	45.3	153
	7.32	0.516	4.77	1.46	3.87
	681000	1050	443000	2970	360000
Galvanized Carbon Steel	Galvanized Carbon Steel	Galvanized Carbon Steel	Galvanized Carbon Steel	Galvanized Carbon Steel	Galvanized Carbon Steel
E-111	E-112	E-113	E-114	E-115	E-116
Fixed Tube	Fixed Tube	Fixed Tube	Fixed Tube	Fixed Tube	Fixed Tube
	97.2	97.2	86.8	492	423
	1.95	1.95	1.61	3.00	2.58
	1620	1620	150000	6105	5241
Galvanized Carbon Steel	Galvanized Carbon Steel	Galvanized Carbon Steel	Galvanized Carbon Steel	Galvanized Carbon Steel	Galvanized Carbon Steel

Table 2: Equipment Summary Table Continued (Pumps)

P-103 A/B	P-104 A/B	P-105 A/B	P-106 A/B	P-107 A/B	P-108 A/B	P-109 A/B	P-110 A/B	P-111 A/B
	46	634	198	328	282	282	282	238
	2.7	20.3	7.61	8.1	6.84	59.2	59.2	7.19
	.4	.75	.6	.7	.65	.65	.65	.7
	7.52	13.6	7.44	13.3	7.37	7.37	7.37	7.52
	48.8	57.8	48.3	44.4	35.8	391	391	45.9
	41.3	44.3	40.9	31.1	28.4	383.7	383.7	38.4
Centrifugal	Centrifugal	Centrifugal	Centrifugal	Centrifugal	Centrifugal	Positive Displacement	Positive Displacement	Centrifugal
Galvanized Carbon Steel	Galvanized Carbon Steel	Galvanized Carbon Steel	Galvanized Carbon Steel	Galvanized Carbon Steel	Galvanized Carbon Steel	Galvanized Carbon Steel	Galvanized Carbon Steel	Galvanized Carbon Steel

Table 2: Equipment Summary Table Continued (Vessels/Towers)

T-104	T-105	T-106	T-107	T-108	T-109	T-110	T-111
Adsorption	Adsorption	Adsorption	Adsorption	Adsorption	Adsorption	Adsorption	Adsorption
230	442	230	442	230	442	230	442
64.7	388	64.7	388	64.7	388	64.7	388
17750	17750	17750	17750	15590	15590	15590	15590
Horizontal	Horizontal	Horizontal	Horizontal	Horizontal	Horizontal	Horizontal	Horizontal
Galvanized Carbon Steel	Galvanized Carbon Steel	Galvanized Carbon Steel	Galvanized Carbon Steel	Galvanized Carbon Steel	Galvanized Carbon Steel	Galvanized Carbon Steel	Galvanized Carbon Steel
317	317	317	317	265	265	265	265
15.4	15.4	15.4	15.4	14.5	14.5	14.5	14.5
5.12	5.12	5.12	5.12	4.83	4.83	4.83	4.83
Aluminum Oxide	H-ZSM-5 Catalyst	Aluminum Oxide	H-ZSM-5 Catalyst	Aluminum Oxide	H-ZSM-5 Catalyst	Aluminum Oxide	H-ZSM-5 Catalyst

Table 2: Equipment Summary Table Continued (Tanks)

-102	Tk-103	Tk-104	Tk-105	Tk-
0	200	200	200	200
7	14.7	14.7	14.7	14.7
5	1,353	1,605	1,353	1,1
5	4,059	11,235	9,471	7,7
Galvanized Carbon Steel	Galvanized Carbon Steel	Galvanized Carbon Steel	Galvanized Carbon Steel	Gal
	20	27	28	24
	41	55	52	48

Table 3: Utility Summary Table

Condensate	Hot Oil In	Hot Oil Out	Boiler Feed Water Usage	Low Pressure Steam Generation	Cooling Water
Condensate	Hot Oil Supply	E-103, E-106, E-107, E-110, E-111, E-112, E-113, E-114	Boiler Feed Water Supply	E-104, E-106, E-108, E-109, E-115, E-116, E-117, E-118	Cooling Water
	E-103, E-106, E-107, E-110, E-111, E-112, E-113, E-114	Hot Oil Return	E-104, E-106, E-108, E-109, E-115, E-116, E-117, E-118	LPS Supply	E-102
	750	725	80	298	87
	244.7	214.7	64.7	64.7	84.7
	0.00	0.00	0.00	1.00	0.00
	31.58	32.53	62.81	0.1475	62.63
	-484.2	-504.7	-6827	-5678	-6820
	2030000	2030000	49100	49100	1669

Economics

Capital Cost Estimate

The capital cost of the design was estimated by evaluating the cost of each piece of equipment separately. Before evaluating the cost of each piece of equipment, the equipment was sized following heuristics given in *Analysis, Synthesis, and Design of Chemical Processes* [4]. These heuristics can be found in Chapter 11 and were used in conjunction with given specifications of process values and values found from the design simulation to find the required size of each piece of equipment. After calculating the size of each piece of equipment, the equipment was costed by using heuristics given in the same textbook [4]. Following the equations given in the appendix and utilizing coefficients defined by equipment design, the group was able to evaluate the cost of each piece of equipment. Also, the cost associated with the controls system utilized in the design process was estimated to be equal to 20% of the capital evaluated from equipment [4]. The total value for the capital cost investment for this design was evaluated to be \$19.6 million. This value was evaluated on the basis of U.S. dollars in the year 2021 for the Singapore location as defined in the provided Appendix 1 [5]. A full list of pieces of equipment and the capital cost associated with each piece of equipment is given in Table 5.

Variable Cost Estimate

The variable cost was estimated using specified rates given in the provided information in Appendix 1 [5]. Utilities were determined based on design requirements and a cost comparison comparing variable and capital costs associated with competitive utilities. For example, high pressure steam and hot oil were investigated to be used in E-110, E-111, E-112, and E-113 because both utilities could be used to meet design specifications. However, after a cost analysis comparing capital and variable costs associated with these utilities used in this capacity, it was determined that hot oil should be utilized because it provided greater economic benefit. The same method was used in evaluating E-103, and in the case of E-101, low pressure steam and hot oil were tested competitively. Also, in the case of E-104 and E-106, air coolers were considered along with steam generation with the generation of low-pressure steam ultimately being chosen for this design after being compared with air cooling on an economic basis.

The utility cost associated with each piece of equipment was calculated from corresponding rates, and these rates are referenced below in Table 4. This cost is presented as variable cost along with capital cost in Table 5. It should be noted that the fuel gas utility is directly related to the heat duty required of the hot oil used in the design process as the fuel gas is utilized in a furnace that is already present and available for use to provide heat to the hot oil [5]. The heat transfer of the fuel gas to the hot oil was assumed to be 95% efficient meaning that more heat was required of the fuel gas to add to the hot oil than what was required of the hot oil to supply to the process [6]. Also, it is worth noting that the utility cost rate for boiler feed water was an assumed value that the group derived from the cooling water utility cost rate given. The

boiler feed water cost rate was assumed to be 50% greater than the cooling water utility cost because boiler feed water is supplied at a greater purity than cooling water. This results in a cost rate of \$0.75 USD / MBTU for the boiler feed water. However, the heating value associated with boiler feed water was assumed to be greater than the heating value associated with cooling water meaning that boiler feed water should come at a lower cost rate since more energy may be absorbed by the boiler feed water. By using the heating value of the cooling water divided by the heating value of the boiler feed water as a conversion factor, a new utility cost rate for boiler feed water was calculated. This new utility cost rate was now in terms of heating value of the boiler feed water. The new cost rate was utilized in the design process for calculating boiler feed water cost when used to cool significant areas where waste heat recovery was considered. From these considerations, the total variable cost for the design process was evaluated to be \$1.99 million per year, and this value was evaluated on the same basis of U.S. dollars in the year of 2021 in Singapore [5].

Table 4: Utility Cost Rate Summary Table

Utility	Utility Cost Rate
Electricity	\$0.25 USD / kW-hr
Fuel Gas	\$15.00 USD / MMBTU HHV
Cooling Water	\$0.50 USD / MBTU
LP Steam	\$22.90 / 1000kg
Boiler Feed Water	\$0.0315 / MBTU

The sensitivity of the variable cost of the design process was also considered and evaluated through single variable analysis presented in Figure 5 which is a tornado chart.

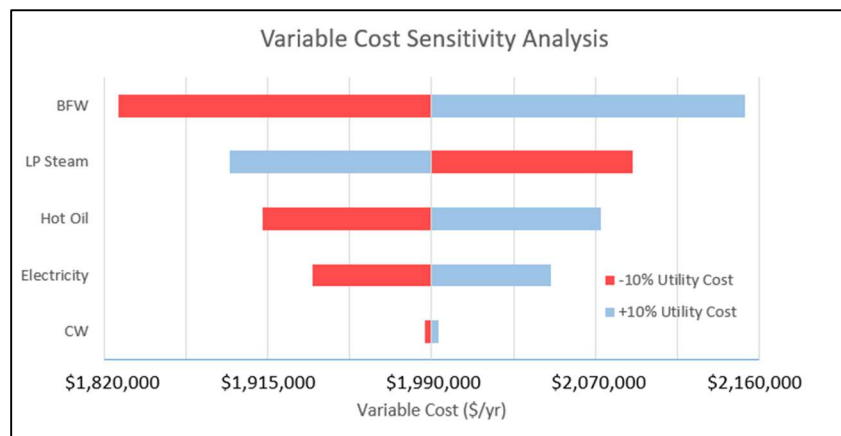

Figure 5: Variable Cost Sensitivity Analysis

Fluctuations in each utility were considered for the purpose of presenting the dependence of the variable cost on each utility to highlight the importance of some utilities in the design process over others. The fluctuations were evaluated as a 10% increase or decrease in the utility cost rate of each utility, and each utility was considered with the other utilities retaining the same utility cost rate. With the assistance of a tornado chart, the dependence of the variable cost on each utility can be clearly interpreted.

As detailed in Figure 5, each utility price listed was increased and decreased to determine the overall effect of each utility on the variable cost. In most cases, a decrease in the utility cost price resulted in an overall decreased variable cost. However, in the case of low-pressure steam, the relationship between the variable cost and utility cost was inverse. As the utility cost of the low-pressure steam decreased, the overall variable cost increased and vice versa. This was determined to be the case because the design process generates low-pressure steam, and, as a result, any decrease in the value of the low-pressure steam would result in a rise in variable cost. In the same way, any increase in the utility cost of low-pressure steam would result in a decrease in the variable cost as this would mean more value was added to the process through the avenue of low-pressure steam generation. Overall, boiler feed water was found to have the greatest impact on variable cost in the case where the utility cost of the boiler feed water was influenced in any way. This is due to heavy dependence on boiler feed water in the design process in any case that requires significant cooling from high temperatures. On the contrary, cooling water was discovered to have the least significant impact on variable cost given a change in cooling water utility cost. This is because the design process only utilizes cooling water in one application in the process. The process overall operates at such high temperatures that any attempt to use cooling water as a heating medium in these cases would result in boiling of the cooling water and fouling of heat exchanger tubes or would result in the use of large amounts of cooling water that would ultimately be an economically unsound idea. Below, the capital cost and variable cost associated with each piece of equipment are summarized.

Table 5: Equipment Cost Summary Table

Equipment	Tk-101	Tk-102	Tk-103	Tk-104	Tk-105	Tk-106	Tk-107	E-101	E-102	E-103
Capital Cost (thousand \$)	\$2,570	\$1,220	\$1,170	\$1,590	\$1,500	\$1,400	\$1,090	\$80.0	\$102	\$125
Variable Cost (thousand \$/yr)	N/A	N/A	N/A	N/A	N/A	N/A	N/A	\$44.0	\$33.7	\$233
Equipment	E-104	E-105	E-106	E-107	E-108	E-109	E-110	E-111	E-112	E-113
Capital Cost (thousand \$)	\$80.7	\$125	\$75.4	\$141	\$113	\$102	\$80.8	\$80.8	\$79.1	\$79.1
Variable Cost (thousand \$/yr)	\$10.8	\$152	\$30.6	\$123	\$91.4	\$96.0	\$72.3	\$72.3	\$62.0	\$62.0
Equipment	E-114	E-115	E-116	E-117	E-118	T-101	T-102	T-103	T-104	T-105
Capital Cost (thousand \$)	\$78.0	\$122	\$115	\$113	\$81.2	\$344	\$312	\$288	\$155	\$164
Variable Cost (thousand \$/yr)	\$51.3	\$62.8	\$53.9	\$123	\$36.9	N/A	N/A	N/A	N/A	N/A
Equipment	T-106	T-107	T-108	T-109	T-110	T-111	D-101	D-102	D-103	D-104

Capital Cost (thousand \$)	\$155	\$164	\$138	\$146	\$138	\$146	\$8.71	\$27.1	\$47.6	\$124
Variable Cost (thousand \$/yr)	N/A	N/A	N/A	N/A	N/A	N/A	N/A	N/A	N/A	N/A
Equipment	P-101 A/B	P-102 A/B	P-103 A/B	P-104 A/B	P-105 A/B	P-106 A/B	P-107 A/B	P-108 A/B	P-109 A/B	P-110 A/B
Capital Cost (thousand \$)	\$91.7	\$35.8	\$79.7	\$42.6	\$79.7	\$59.5	\$59.5	\$75.7	\$269	\$269
Variable Cost (thousand \$/yr)	\$52.5	\$0.396	\$43.1	\$5.75	\$43.2	\$16.2	\$17.2	\$14.5	\$98.2	\$98.2
Equipment	P-111 A/B	P-112 A/B	P-113 A/B	P-114 A/B	P-115 A/B					
Capital Cost (thousand \$)	\$51.6	\$231	\$231	\$48.2	\$39.8					
Variable Cost (thousand \$/yr)	\$15.3	\$78.6	\$78.6	\$13.0	\$6.96					

Fixed Cost Estimate

Fixed Cost associated with the design process was determined to be any cost that was realized every year of the project life but was independent of process flow rates. This resulted in a fixed cost that was summated from the cost assumed from the salary of newly hired operators required to run the process, the maintenance on various pieces of equipment, and the cost of catalyst utilized in the adsorption section of our process that would need to be replaced at different intervals throughout the year. The cost associated with operator salary was determined by first calculating the approximate number of operators required to run the design process. This number was found by using an equation in *Analysis, Synthesis, and Design of Chemical Processes* [4]. This equation details how to approximate the number of operators from the number of key equipment in the design process. In the case of this design, the number of key pieces of equipment was determined to be 29 with 11 towers and 18 heat exchangers. From this value and using the equation, the number of operators required to run this design process was determined to be 17 operators. The cost associated with the salary of each operator was estimated to be equal to \$39,000 USD per year given salaries in Singapore converted from \$54,000 Singapore dollars per year [7]. The maintenance costs for the design process were estimated to be equal to 6% of the total capital cost for the project [4]. Based on costs found for the design catalysts, H-ZSM-5 and Aluminum Oxide, the fixed costs for each catalyst were evaluated. The fixed costs for each catalyst were associated with the number of times each catalyst bed had to be replaced per year. The total fixed cost was estimated to be \$4.35 million. The fixed costs associated with operator salaries, maintenance, and catalysts are given below in Table 6.

Table 6: Fixed Cost Summary Table

Fixed Cost Variable	Cost (\$/yr)
Operators	\$663,000
Maintenance	\$980,000
H-ZSM-5	\$2,110,000
Aluminum Oxide	\$599,000

Process Safety

Minimizing Environmental Impacts

At all points in the process, design practices were followed in an effort to maintain containment of the process streams. Each step in the process was designed to run continuously to limit entry and exit points to the process. Relief devices were designed to make sure that even during over pressure events pressure would not continue to build in vessels which may result in rupture. Relief devices were designed to send the material to a relief header which would subsequently send all content through a flare. The flare would fully combust the relief material and have little to no harmful chemical release outside of CO₂.

With consideration to the humid and salty environment of the plant location, galvanized carbon steel was selected as the material of construction. This selection limits the corrosive effect of the seaside location, protecting the equipment from undue wear and tear and minimizing the probability of loss of containment due to equipment failure [8]. Additionally, to reduce loss of containment in regard to emissions to atmosphere, API floating roof tanks were chosen for feed, product, and intermediate storage of hydrocarbon streams.

This process will help close the gap to a circular plastics economy, which ultimately would make recycling more financially viable. This advancement would allow for a larger scale adoption of recycling processes that would allow for the reuse of plastics in a new and innovative way. Being able to reuse plastics reliably would encourage recycling rates and could be used to clean up current pollutants made from recyclable material.

Another way this process tries to limit its environmental impact is through steam generation. At many points in the process, streams are at high temperatures and require cooling and reclaiming that energy through steam production is not only a better financial decision, but also a better environmental decision. The steam that is generated will be used to produce electricity and will reduce the overall energy consumption of the PyOil purification process. With a reduction in energy consumption, CO₂ production from the process would decrease.

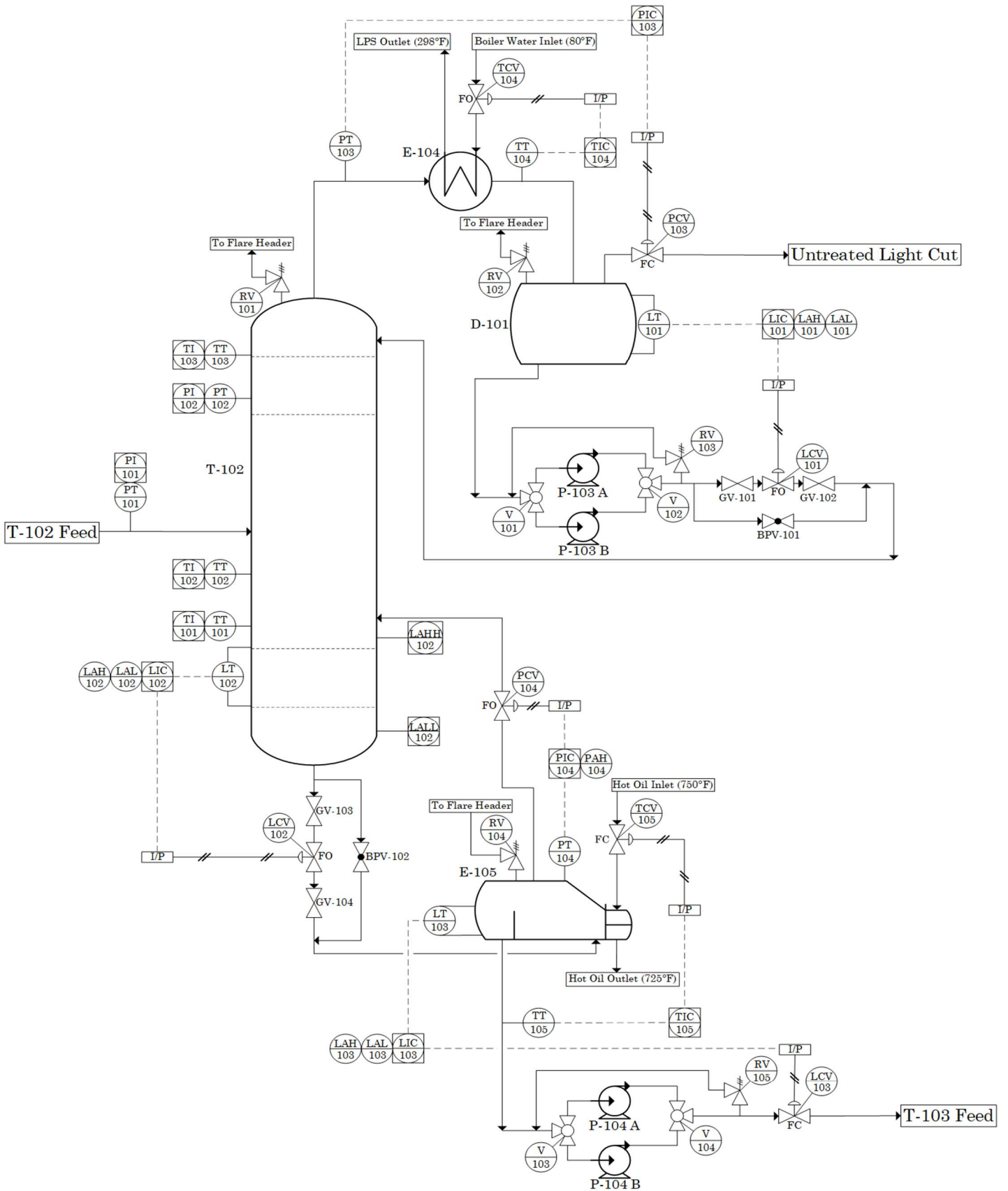

Figure 6: Piping and Instrumentation Diagram for Light Cut Tower (T-102)

Pressure Relief Valve Sizing

A pressure relief valve was sized for the column T-102 according to standard sizing conventions under the assumption that a fire event would be the worst-case scenario for relief requirement. This assumption was made due to the high flammability of the tower material and the resulting reactions that would occur following loss of containment. Using the material properties of the column's vapor, it was found that in a fire event a relief flow rate of 5,240 lb/hr would be necessary. Using this flow rate and additional material properties at the discharge conditions, it was found that the required orifice area for a conventional relief valve would be 0.049 in². This led to the choice of a Class D Standard Orifice Designation 1.5 x 2.5 Conventional Relief Valve with a set pressure of 71.6 psig for column T-102. The internal design of a generic conventional relief valve is shown below in Figure 7.



Figure 7: Conventional Relief Valve [9]

Failure Rate Analysis

The failure chance for each piece of equipment in the system was created from research that was done on relative accident percentages associated with different equipment types [10]. This was then analyzed through a simplified form of fault tree analysis to determine the frequency that equipment in the process would be affected, and the resulting amount of the process that would be affected. Figure 8 is used in the failure rate analysis with the percentages on the chart representing the likelihood of a failure event occurring at a certain progress point of the process with eight total progress points. The numbers in the legend show the percentage of the process that would be affected by a failure at that point based on the number of affected units. For example, there is a 7.37% chance that a failure will occur in the second progress point which will affect the remaining 88.24% of process units.

Failure Percentage Analysis by Process Progression

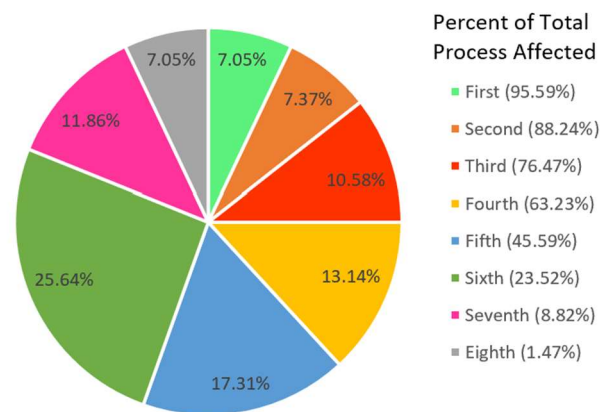

Figure 8: Failure Percentage Analysis by Process Progression

The second part of the failure rate analysis relies on the rates of failure. For this value the group consulted a study done over computer systems failures in chemical plants over a span of two years in the United Kingdom [11]. This found that computer system failure for single systems occurs roughly once per year (100 failures per 1 million hours) with hardware failures occurring more frequently (a 400% increase was assumed). This rate of 5 hardware failures per year associated with the values in Figure 8 results in an expected yearly failure value greater than 0.5 for all regions except the first, second, and the eighth. This would mean it is expected that in these regions, roughly half of a failure would result per year, with 5 failure events in a year, our focus should be on monitoring these regions which equate roughly to all of the Light cut processing, Medium cut processing up to the dehalogenation units, and all of the Heavy cut processing.

Personnel Exposure Risk

To limit the risk of personal injury, many factors should be implemented by management and when looking at detailed design. Management should foster a safety culture which encourages learning/competency, accountability, issue reporting, maintaining a sense of vulnerability, supporting and validating concerns, a high level of communication, and a clear emphasis on both process and personal safety. Management should develop adequate training, competency checks, and maintenance routines for all operators and contractors who would work at the plant. Teams that are concerned with detailed design should create proper signage that communicates and reminds operators of risk for each piece of equipment. Finally, proper PPE, emergency procedures, and relevant reference material should be provided by management to limit specification production, accidents, and personal injuries.

To evaluate the potential risk of the mixture during process operation and in the event of loss of containment, a summary of the NFPA diamonds for each individual component was compiled, and a chemical compatibility matrix was summarized in Figure 9 below.

NFPA Health	NFPA Flammability	NFPA Reactivity	NFPA Specific Hazard	Py Oil Compatibility Chart	1-BUTENE	1,3-BUTADIENE	2-BUTENE	BUTANE	CARBON DIOXIDE	CARBON MONOXIDE	ETHANE	ETHYLENE	HYDROGEN	ISOBUTYLENE	METHANE	N-HEXANE	N-PENTANE	NITROGEN	PROPANE	PROPYLENE	
1	4	0			X																
2	4	2			C	SR															
1	4	0			Y	C	X														
1	4	0			Y	C	Y	X													
2	0	0	SA		Y	C	Y	Y	X												
3	4	0			Y	N	Y	Y	Y	X											
1	4	0			Y	C	Y	Y	Y	Y	X										
2	4	2			C	C	C	C	C	N	C	SR									
0	4	0			Y	N	Y	Y	Y	Y	Y	N	X								
2	4	1			C	C	C	C	C	N	C	C	N	SR							
2	4	0	SA		Y	C	Y	Y	Y	Y	Y	C	Y	C	X						
2	3	0			Y	C	Y	Y	Y	Y	Y	C	Y	C	Y	X					
1	4	0			Y	C	Y	Y	Y	Y	Y	C	Y	C	Y	Y	X				
0	0	0	SA		Y	C	Y	Y	Y	Y	Y	C	Y	C	Y	Y	Y	X			
2	4	0			Y	C	Y	Y	Y	Y	Y	C	Y	C	Y	Y	Y	Y	X		
1	4	1			Y	C	Y	Y	Y	Y	Y	C	Y	C	Y	Y	Y	Y	Y	X	

LEGEND

- X No self reaction
- N Not Compatible
- C Caution
- Y Compatible
- SR Self Reactive
- SA Simple Asphyxiant

Figure 9: NFPA Summary & Chemical Compatibility Chart

Figure 9 was compiled using the AIChE Chemical Reactivity Worksheet [12] and the NFPA values were checked against individual SDS [13-29] to ensure accuracy. With the NFPA diamond summary, the main hazard with PyOil purification process is flammability (with most chemicals having an NFPA rating of 4) and there should be a high level of concern about limiting ignition sources around the facility in the event of a loss of containment. In order to limit risk, process streams were designed to not be heated by an open flame, and maintenance with potential ignition (welding, drilling, cutting, etc.) should only happen on processes that are not currently operating.

Although the worksheet warns there are a few combinations of non-compatible compounds, the software modeled each scenario as binary mixing in a pressure vessel which is very different than the conditions that will be seen during PyOil purification. Each of the problematic mixtures contains compounds found in very small concentrations (less than 0.2% by weight in the feed) so there should be very little interaction even when concentrated during distillation. When interacting, the reactions from these mixtures are very exothermic and can produce a decent amount of pressure. This would be very worrying for binary processes where the two compounds interacting are the only major components, since these mixtures could have runaway reactions, but these reactions will happen sparingly over the PyOil purification process. It's also important to note that these compounds are found in the feed mixture so caution surrounding potential addition of compounds by mixing is not necessary.

Table 7 expands on potential risk of chemicals during exposure by detailing the LC-50 and TWA of each of the major components. TWA stands for time weighted average, and it is the maximum concentration of exposure that OSHA (the Occupational Safety and Health Administration) has deemed permissible over an 8-hour period. LC-50 is the exposure concentration of a chemical over the course of a 4-hour period which caused the fatality of 50% of tested animals. Both TWA and LC-50 are measured in ppm, or parts per million.

Table 7: Toxic Concentration of Process Chemicals

	Nitrogen	Hydrogen	Carbon Monoxide	Carbon Dioxide	Methane	Ethane	Ethylene	Propane
LC-50 (ppm)	N/A	N/A	1,300	40,000	N/A	658	N/A	>800,000
TWA (ppm)	N/A	N/A	25	5,000	N/A	1,000	N/A	1,000
	Butane	1,3 Butadiene	Pentane	Hexane	Isobutylene	1-Butene	2-Butene	Propylene
LC-50 (ppm)	658	128,000	364	48,000	620	34,500	34,500	65,000
TWA (ppm)	800	2	1,000	500	250	250	250	500

With TWA and LC-50, the lower the number the higher the risk associated with a given chemical. Pentane has the lowest LC-50 at 364 ppm and 1,3 Butadiene has the lowest TWA at 2 ppm. While it might seem that LC-50 and TWA should follow the same trend, they give different metrics for safety. LC-50 is concerned with lethality from exposure, while TWA is concerned with injury from exposure. Some chemicals will be harmful at low concentrations but not lethal

until high concentrations, and some chemicals are not harmful until close to lethal concentrations.

Atmospheric Detonation of Distillation Inventory

The most common process incidents within chemical plants are fires, explosions, and toxic releases. To minimize consequences from explosions, a TNT equivalency of atmospheric detonation, or uncongested vapor cloud deflagration, analysis was performed.

Table 8: TNT Detonation Equivalency

	r (ft)	Z_e	P_o/P_a	Scaled Overpressure
M_{TNT} (lbs)	5	0.363	136.0	1999.00
	10	0.726	38.8	570.26
2607	50	3.63	1.078	15.84
	75	5.45	0.495	7.27
Atmospheric Pressure	100	7.27	0.309	4.55
	150	10.9	0.176	2.59
14.7	300	21.8	0.0790	1.16
	500	36.3	0.0462	0.68
	1000	72.7	0.0229	0.34

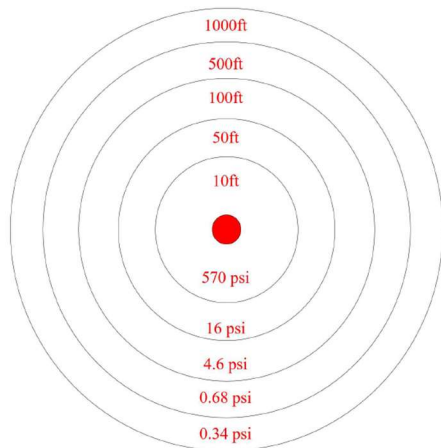

Peak overpressure	Maximum wind speed	Effect on structures	Effect on the human body
1 psi	38 mph	Window glass shatters	Light injuries from fragments occur
2 psi	70 mph	Moderate damage to houses (windows and doors blown out and severe damage to roofs)	People injured by flying glass and debris
3 psi	102 mph	Residential structures collapse	Serious injuries are common, fatalities may occur
5 psi	163 mph	Most buildings collapse	Injuries are universal, fatalities are widespread
10 psi	294 mph	Reinforced concrete buildings are severely damaged or demolished	Most people are killed
20 psi	502 mph	Heavily built concrete buildings are severely damaged or demolished	Fatalities approach 100%

Figure 10: Equivalency Blast Map [30]

It was found that the TNT equivalent to tower detonation was 2,607 lbs of TNT. This equivalent amount of TNT causes significant damage within 100 ft of the tower where most if not all buildings and structures collapse or are severely damaged (even with reinforced structures). Fatalities are also widespread within 100 ft and are nearly guaranteed within 50 ft of the tower. Around 500 ft both damage and injuries fall off dramatically, making this a decent minimum distance to evacuate to in the event of a fast-acting emergency. But ideally, it would be encouraged to not build any facilities or controls areas where personnel would be regularly working within 500 ft of the distillation towers; and it should be encouraged to evacuate more than a thousand feet from the distillation towers to limit personnel harm in the event of a catastrophic failure. Additionally, the three distillation towers should not be built within 500 ft of each other to prevent a chain reaction of catastrophic failures with a given event.

Hazard and Operability Study of a Distillation Tower

Table 9 is a hazard and operability study (HAZOP study) of running the second distillation tower since it is the largest of the three distillation towers presenting the most inherent risk. The study can be extended to any of the three distillation towers designed for the PyOil purification process since these risks are characteristic of distillation. The HAZOP study provides a systematic way of ensuring that all potential risks in running the distillation tower are addressed appropriately in the preliminary design to prevent accidents, injuries, and fatalities.

Table 9: HAZOP Study for a Distillation Tower

Guide Word	Deviation	Cause	Consequence	Action
No	No flow into column	Feed valve fails closed or blockage in feed line	Column profile changes over time, less production	Shut down column and remove blockage or fix valve
	No flow out top	Block in condenser line	Pressure increase, low to no reflux rate	Shut down column and remove blockage
	No flow out bottom	Blockage in pipe to reboiler	Liquid accumulation in column	Shut down column, drain fluid before restarting, and remove blockage
	No bottom of column liquid level	Break in piping, column bottom, or mis calibrated valve	Potential to run pump and reboiler dry causing damage	Turn down or off reboiler to lower vapor production until liquid level is established
	No vapor production	Boil up line blocked or ruptured	Large amount of liquid production and flooding in column	Shut down column until the line is fixed
	No standing liquid on trays	Incorrect weir height, tray not seated properly	Poor separation, products not up to specification	Inspect trays and column seating during maintenance
	No heat added to column	Ruptured steam line	Large amount of liquid production and flooding in column	Shut down column until the line is fixed
	No reflux	Broken pipes in condenser	Light cut composition is not up to specifications	Shut down column and fix piping in condenser
	No relief in the event of overpressure	Polymerization stops pressure relief valve opening	Column builds up pressure until failure	Rupture disk placed before pressure relief valve

Table 9: HAZOP Study for a Distillation Tower (continued)

Guide Word	Deviation	Cause	Consequence	Action
More	More feed flows in	Feed valve failure	Higher liquid level in column, poorer separation	Calibrate or replace feed valve
	More heat added than expected by reboiler	Leak in tubing steam coming through	Higher vapor production, potential to overpressure reboiler	Calibrate controls and inspect reboiler during maintenance
	More pressure than expected in top of column	Failure of automatic control	Relief device opens and potential product is lost	Closely monitor (and recalibrate) controls and review data from the failure event
	More heat taken away than expected by condenser	Rain or cold ambient temperatures cooling the process streams	Small increase in liquid production, possible to change light cut composition	Change condenser flow rate/set point until regular conditions resume
	More pressure in middle of column	Blocked vapor flow through trays	Deviation of product composition	Is severe enough, shut down column for maintenance
	More viscous feed stream	More polymerization reactions than normal	Less vapor flow through the column, higher pressure differential	Communicate with feed supplier if event is proven to be contaminated feed
	More water content in feed stream	Wet plastics prior to pyrolysis	No significant change to distillation	No action necessary
	More fine solid particles in solution than normal	Possibility in variation with pyrolysis	More solids depositing in bottoms of column and on trays, potential to block flow	Closely monitor until cleaning and maintenance is necessary
	More corrosion than expected	MOC interacting with chemicals or contaminants over time	Decreasing performance until out of spec products	Replace affected equipment with different MOC or add a pre treatment process
	More wind than expected	Environmental conditions	Wind strain that could endanger the column	Add supports and monitor the column condition closely
Less	Less pressure in feed stream	Feed pump beginning to fail	Not steady flow rate or lower feed rate	Switch pump to spare
	Less vapor production	Column not reboiling properly or higher pressure than expected	Poor separation, products not up to specification	Check the reboiler and lines going to and from it, recalibrate controls system
	Less liquid production	Column not refluxing properly or lower pressure than design	Poor separation, products not up to specification	Check the condenser and lines going to and from it, recalibrate controls system
	Less frequent maintenance than required	Potential company savings at the expense of quality/safety	Equipment and control deterioration, deviation from set points or specifications	Maintain a sense of vulnerability and emphasize importance of consistency
	Less reflux flow into column than designed	Partially closed reflux valve	Liquid accumulation in reflux drum	Check (and calibrate) reflux valve and reflux piping
Reverse	Reversed feed flow	Lower feed pressure than feed stage	Back pressure on the feed pump	Switch to spare feed pump and examine the feed line for leaks and fix pump
	Reversed reflux flow	Reflux tank runs dry, condenser not working	Off specification production, possible equipment damage	Shut down process and inspect the condenser and the cooling water lines
	Reversed boil up flow	Reboiler not working and/or liquid level rises above boil up outlet	Off specification production	Shut down process and inspect reboiler, boil up line, and bottom of column

Table 9: HAZOP Study for a Distillation Tower (continued)

Change in	Change in cooling water pressure	Disturbance in cooling water system	Negligible, should be designed to address this	None needed
	Change in steam pressure	Disturbance in the steam line	Negligible, should be designed to address this	None needed
	Change in atmospheric pressure	Natural fluctuation	Negligible, should be designed to address this	None needed
	Change in pressure gradient across column	Automatic control loop failure, vapor or liquid production rates change	Greater/Lower individual cut production rates	Trouble shooting control loop
	Change in temperature gradient across column	Automatic control loop failure, vapor or liquid production rates change	Greater/Lower individual cut production rates	Trouble shooting control loop
	Change in ambient temperature	Weather cycles	Automatic controls system should adjust production	None needed
	Change in feed composition	Large variation in feedstock to pyrolysis	Greater/Lower individual cut production rates	Communicate with pyrolysis unit
	Change in contamination	Large variation in feedstock to pyrolysis	Potentially more fouling	Communicate with pyrolysis unit, add decontamination post pyrolysis if constant issue
Other	Loss of power	Happenstance	Pumps shut off; controls momentarily shut off	Stop production until power is consistent
	Natural disaster occurs	Happenstance	Depends on severity of the event, could leave the process inoperable	Fix process appropriately and prepare for likely disasters that could occur (i.e. monsoons)
	Sabotage or vandalism	Inadequate security or oversight	Could be surface level, or process could be inoperable	Fix process, increase security, interview personnel
	Loss of containment from a leak	Material corrosion or failure; sealant failure	Loss of product; fines; potential fire, could lead to equipment failure	Watch flowrates throughout process for flow continuity;
	Fire	Happenstance; leak and accidental ignition	Possible overpressure, equipment damage, injuries, pressure relief required	Shut down plant and take appropriate firefighting methods
	Incorrect controls override by controls operator	Inexperience; misinterpretation of data; stress from alarms or off spec production	Poor separation, variety of production errors explored above	Increase oversight of column controls if inexperienced and during events that deviate from standard production
	Alarm failure during high/low liquid level event	Liquid level alarm failure	Could impair separation and run pump or reboiler dry	Replace or troubleshoot alarm

Recommendations for Improvement of the Bali Sorting Facility

Introduction to Cold Eyes Review

In efforts to better understand the varying culture and geography of Bali for the purpose of creating meaningful recommendations, an interview was conducted with James Maxwell a cofounder of BeachBins. BeachBins is a non-profit organization aimed at cleaning waste from the shorelines of Bali primarily along the southwestern coast with locations as close as 40km to Jembrana, validating Maxwell's firsthand experience.



Figure 11: Map of Bali & Areas of Focus

Maxwell revealed three major points for our analysis. First, the people of Bali have a strong single use/disposable culture regarding waste. He pointed out how before the introduction of plastics the citizens of Bali would eat their meals off a banana leaf and then let the wind take the leaf. With plastics replacing many of the previous environmentally safe practices, the buildup and reckless misuse of waste became rampant. Next, Maxwell stated that each region/municipality was self-governed for the most part, especially pertaining to the management of waste. His disclosure posed pros and cons regarding improvement and replication of the sorting facility. This is an advantage as there are less restrictions when implementing and evolving systems for collection and sorting, but replication will be difficult as Bali lacks standardization for waste management as a whole. Lastly, individuals were revealed to be best motivated by currency. Maxwell noted how most of the people he interacted with pursued

multiple forms of income. He stated that anything that improves their bank account is the best driver for participation.

The provided “Cold Eyes Review” recommendations are based on generating more throughput with minimal capital cost. There are multiple other and potentially better alternatives but would cost magnitudes more capital without the corresponding benefits, so they are not considered in overall recommendations. With that said, these recommendations were also generated on the assumption that to create more cash flow than present value, more capital needs to be spent than current expenses.

Recommendations for Closing the Quality Gap

A mechanical step in shrinking the quality gap is introducing fine mesh rotary sieves to the tail end of plastic sorting (directly before the final manual sorting by categories). The sieves will act to reduce residual contaminates i.e., granular or liquid non-plastic, on flexible and rigid plastics. The rotary sieves are lost cost and already in place on the organic side of the facility, so no additional training or safety is necessary for installment. Further quality improvement will occur beyond the confines of the sorting facility.

Maxwell’s interview established that community education and involvement is paramount to waste sorting success. To expand on the current community-based programs, the recommendation is to expand the efforts to business participation as well. Involving the tourism and manufacturing organizations in Bali will not only generate more streams of sorted waste but also extend awareness to the employees and therefore residents. If citizens of Jembrana are exposed to proper waste management at their place of employment, they may be encouraged to participate at home. The benefits to the partaking businesses are claiming clean practices on their environment and social governance standards.

With all the time and resources devoted to community education and involvement, the recommendation to improve plastic quality is to lean into the community and create a third bag in the color coated system. We recommend yellow as the bright color will call attention when disposing of waste, but any new color is acceptable. A third bag will shift sorting capacity from the facility to the households without much added cost. For further household sorting to occur the barrier of entry would need to be lowered, and with the existing bin distribution program this would be a minor additional capital cost.

An all-plastic feedstock would automatically reduce the amount of metal and cellulosic contaminates from the pyrolysis plastic and sorting burden on the facility. However, there is the obvious human error potential as residents can mistakenly dispose of their waste. This factor is mitigated by doubling down on the education programs and the fact that manual sorters are not being removed from the process. The benefits equate to a purer waste influx on average and consequently less sorting responsibility on manual laborers. In turn, manual labor will be capable of processing more units of waste per day than current rates, closing the upcoming quantity gap.

Recommendations for Closing the Quantity Gap

Closing the quality gap will automatically affect the quantity gap. Instead of redundant manual sorting by first removing all plastics from the incoming waste then secondarily sorting the plastic stream into HDPE, PP, and PET the three-bag system will streamline waste sorting. With the proposed new three-bag system, the first level of sorting is performed at the households, eliminating the plastic sorting from inorganic waste at the facility which reduces the required manual labor per unit of waste.

To further increase sorting facility plastic throughput, the recommended action is to introduce new equipment to the plastic processing path of sorting. Introducing a cyclone style air blown separator will greatly improve flexible plastic separation. By feeding an all-plastic waste stream through the updraft cyclone flexible, low density, plastic will float out the top and rigid, higher density, plastic will continue down the cyclone. A simple cyclone apparatus can separate flexible waste from the plastic feed with approximately 85% purity and far greater speed than the manual alternative [31].

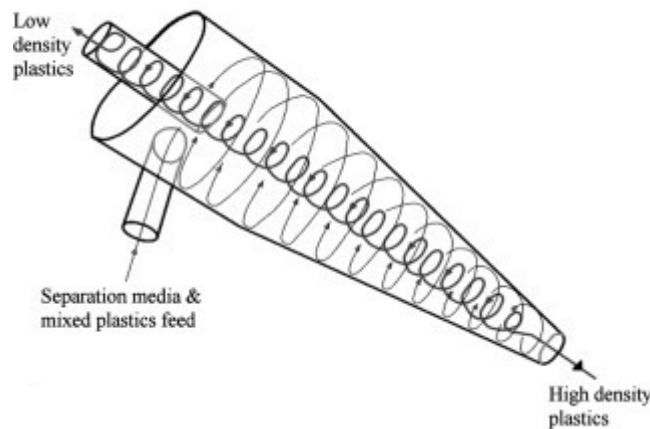

Figure 12: Examples of a cyclone separator [31]

The cyclone is also the most cost-effective solution when compared to industry options. Wet floatation, computer driven air ejectors, and triboelectric separation systems have greater purity outputs than cyclone but cost a great deal more [32]. Considering the relative size of the Bali sorting facility to that of larger scale sorting facilities which employ the above-mentioned alternatives. The recommendation for Bali landed on the smaller and less complex cyclone design.

While the purity is not perfect, the manual sorters who no longer must sort plastic from the inorganic feed will now shift to downstream plastic sorting. One half will sort the rigid plastics into their separate categories like the current process and the other will work to pick out the entrained impurities in the flexible stream.

The cyclone will also close the quality gap and the heavier plastics such as PVC and PET will flow to the bottom of the separator and away from the pyrolysis feedstock. The previously discussed drum sieves will also aid in removing any entrained impurities before they reach the manual pickers.

Recommendations for Closing the Affordability Gap

Both aforementioned recommendations will improve affordability as the level of manual sorting decreases per unit of waste. Shifting sorting responsibility from the facility to the households and mechanical separators. While this is a step in the right direction, it will not greatly improve the affordability of waste collection, transporting, and disposal. To create more revenue, the recommendation moving forward is to monetarily incentivize participation.

Albeit the contradictory advice, calling back to Maxwell's comment on Bali citizen currency driven motivation things become clearer. If the sorting facility can entice citizens to participate with some method of monetary kickbacks, current anecdotal experience dictates that citizens will respond more to money than other types of incentives. This course of action involves dismantling the current door prize incentives and transitioning business models to one resembling electric cooperatives within the United States. The sorting facility becomes a public service where citizens pay for the service throughout the year and the business makes a profit after paying wages, repairs, and improvements. The remaining profit is then split among the participating households. This method will shine in competition among households.

With the current collection method, the region of collection is divided into various routes. Based on number of households per route and a study of average plastic waste produced per household each route produces, goals for plastic waste sorting and collection will be set on a per route basis. Since every collection tricycle is weighed in the current system, recording each routes plastics collection will not be a difficult addition. The route's plastic sorting and collection will be measured throughout the year.

The routes who achieve goal excellence will claim higher percentages of the kickbacks. With such a program, citizens will be enticed to involve their neighbors and so on, creating a natural pathway of increased revenue by way of mouth, competition among routes, and appealing to citizens wallets. Increased household participation is a surefire method for increasing revenue and consequently decreasing the affordability gap.

Cold Eyes Review Conclusion

To better visualize the process flow changes, Figure 13 depicts the changes from current to proposed changes in block flow format. Note that text in red indicated new systems and/or processes to be done. While the current BFD is less complex it requires far more manual labor sorting. The proposed BFD introduces physical separators which reduce required manual labor, thus increasing throughput of the facility.

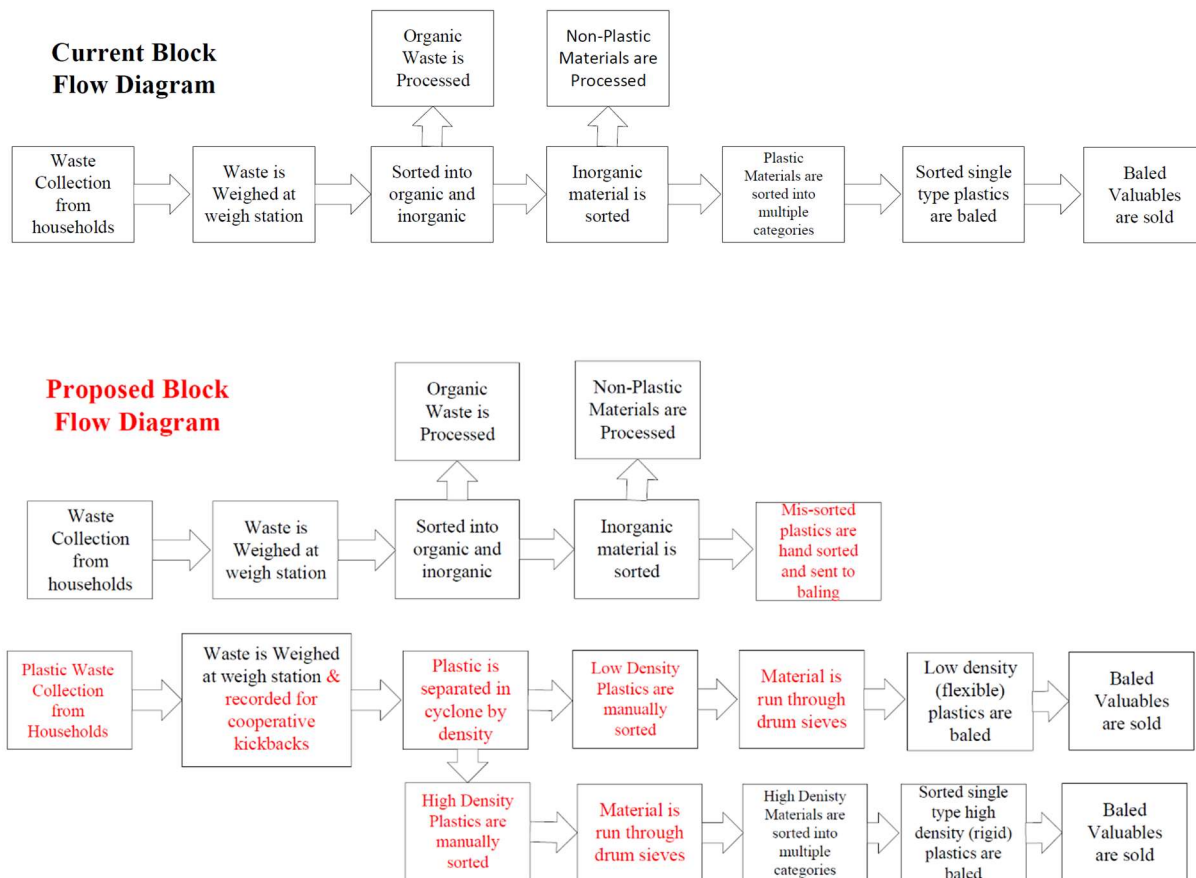

Figure 13: Current and Proposed Block Flow Diagrams for Sorting Process

The quality recommendations were the three-bag system, cyclone separators, and drum sieves all work together to reduce the potential pyrolysis contaminants. Metallic and paper will be effectively eliminated from the plastic feed, if any contaminants leak into the stream by the community disposal mistakes, they will be much smaller in magnitude. Additionally, metals, PVC, and PET contaminants will be sorted through the cyclone and removed from the pyrolysis

feedstock. Paper or cellulosic contaminants would be capable of entering the pyrolysis stream, but they would be minor and requiring one or two manual sorters to ensure stream purity.

The quantity recommendations that coincide with quality equate to less manual sorting required. With less manual sorting, more waste volume can be processed per day improving overall throughput and capacity. To match the capacity increase, the proposed corporate involvement and household cooperative kickback program should encourage new household participation. More households lead to more responsible waste management and affordability for the sorting facility.

The proposed recommendations will change the sorting facility in multiple facets, but each one will compound upon one another in a combined effort of closing the requested quality, quantity, and affordability gaps.

Conclusions

The design process and proposed sorting process that the group has evaluated and considered will provide a new solution in dealing with the plastic waste problem that is currently afflicting the world. Even if it is by a small percentage, this report was written from the perspective that a small change in one part of the world is still a step in the right direction for dealing with the global plastic waste issue. In the case of this design, involving a fractionation section of PyOil feed into PyGas, Light, Medium, Barge Oil, and Coking products, and a purification section of the Light and Medium products, the group believes that the design will meet product specifications. The Light and Medium products will be utilized as feed for a steam cracker, the PyGas as fuel gas in the ethylene plant, and the Heavy cut split into two products for the sake of creating new profitability for the process. Overall, the design was evaluated to cost \$19.6 million in capital cost, \$1.99 million per year in variable cost, and \$4.35 million per year in fixed cost.

In considering changes outside of the plant and inside of the homes of families in Bali, three critical gaps were sought to be closed with new innovative ideas to also take steps toward solving the plastic waste issue. The gaps considered were Quality, Quantity, and Affordability gaps in the Bali recyclable waste collection process. To solve the quality gap, a three-bag system was introduced to shift sorting responsibility from the waste collection company to the households. With an increase in the quality of waste sorting, the quantity gap was filled as a greater separation of waste entering the waste facilities means an opportunity for a greater throughput of recycled products. The quantity gap is also filled with a cooperative program to encourage households to recycle more often because of a kickback that could mean money earned for each household at the end of every year. Both the quality and quantity gap solutions fill the last affordability gap by minimizing cost for waste management facilities in Bali with a lower labor cost per waste delivered.

Appendix - Adsorption Section Detail

Configuration and Considerations with Adsorption Design

When designing the adsorption processes, it was first necessary to understand what each adsorption bed was removing, how that process could be achieved, and what conditions had to be met to ensure a consistent product. For both adsorption processes, alternate adsorbents were used instead of the BASF adsorbents offered in the prompt since it was encouraged to explore and implement alternative adsorbents in an effort to increase affordability. An equal amount of things would need to be assumed or researched for either option since BASF did not publish information about the adsorbents and did not offer this information when contacted by the design team.

The first adsorption process removes heavy metals (such as calcium, iron, lead, & zinc [33]) because these metals could cause fouling and corrosion if sent to the steam cracker [33]. It is very important that the heavy metals are removed before the halogenation step since the halogenation catalyst (H-ZSM-5) is sensitive to heavy metals and the catalyst would be inhibited by heavy metals since it would have greater affinity for the metal ions than halogens. Heavy metal decontamination is a non-regenerable process where adsorbent must be replaced with new adsorbent after becoming spent. Therefore, adsorbent should be as cheap as possible (while still being a viable option to meet product specifications) to give the PyOil purification process the highest chance for success. These factors lead to choosing aluminum oxide as the adsorbent to remove heavy metals in the Light and Medium cuts. Aluminum oxide was run at atmospheric pressure since there were no special requirements for heavy metal removal.

The second adsorption process removes halogens (mainly chlorine from PVC) since these compounds cause corrosion on metal surfaces when they are heated above 900°F [33]. It was decided to use H-ZSM-5 as the adsorbent for this process since it would be able to effectively remove contaminants [34] and be regenerated for repeated use. But removing halogens is not an easy process, so the required conditions for adsorption are less favorable than the heavy metal removal. The dehalogenation adsorption must occur with at least 200°C (392°F) and 20 atm [34], which is achieved through heating with the streams with hot oil and increasing pressure with positive displacement pumps.

Each of the adsorption processes were sized to ensure that adequate interaction could occur with the catalysts, and it was found that zeolite required a retention time of 90 minutes [35]. Aluminum oxide was assumed to have the same retention rate of 90 minutes (explored further below). Adsorption requires an adequate amount of interaction (expressed by retention time) with unspent catalyst which is much easier to achieve when working in batch processes since the process occurs for the required retention time in one location. In order to satisfy the retention time of 90 minutes with a continuous process, the adsorption vessel must be designed to allow for 90 minutes of flow before leaving the vessel. In reality it is unnecessary to design the vessel at this size since the flow through the vessel introduces the Medium or Light cut to unspent catalyst more frequently than when run at a batch scale. The 90-minute retention time is

still a good metric to base sizing assumptions since it will allow for a decent portion of the catalyst to be spent before the product starts deviating from specifications, rather than requiring frequent maintenance to replace catalyst frequently to maintain purity standards.

When designing the adsorption units each unit was modeled to have 15% pressure drop across the column [36]. But to ensure that process conditions would be met throughout the entire vessel, pumps prior to the adsorption units had their discharge capacities increased so that the exiting pressure of the adsorption units was the required design pressure.

Adsorption Design Assumptions

It was assumed that both the Light and Medium cut would need to be liquids during adsorption since one of the given values for adsorption was the LHSV (Liquid hourly space velocity) [2] which is clearly only applicable for liquids. This assumption was backed up by outside research articles which also did decontamination of reclaimed waste plastic oil in liquid state [34][35].

Oversize factor of 10% [4] was used to account for process fluctuations, allowing for larger portions of catalyst to be spent before requiring replacement, and to be able to accommodate additional flow to drain the hold-up tank without requiring both adsorption wings to be operating simultaneously.

Many of the assumptions on adsorbent run time, life span, and price were made to be able to comment on process affordability, but with all of these factors having so much potential variation with implementation, it is highly recommended to contact the adsorbent supplier for each of these details in context of PyOil purification to ensure process success and product purity specifications.

It was also assumed that H-ZSM-5 can be used at least 22 times without a significant decrease in catalytic activity [37]. It was assumed that the Aluminum Oxide would be replaced twice every month in each Medium cut wing, and once every 2 years in the Light cut wing since there was over thirty times as much heavy metal contamination in the Medium cut than the Light cut [33].

It was assumed that aluminum oxide would require the same amount of retention time since resources for adsorption recommendations are very specific, and sources detailing aluminum oxide adsorption did not use it with plastic derived oil. It is likely an overestimation of the actual required retention time, since the adsorption has more favorable conditions (ambient conditions) than the dehalogenation adsorption indicating that the adsorption happens more readily. It is important to note that the increased bed size also helps protect the dehalogenation catalysts from deactivation in the event that heavy metals were not removed.

It was found that just 20 minutes of high temperature nitrogen regeneration were sufficient for regeneration, but it is recommended that the bed be regenerated for an hour to be thorough and ensure regeneration later in the catalyst's lifespan [37]. It was assumed through

similar research that the catalyst would be able to run for 48 hours before needing to be regenerated, leading to adsorption switching from one wing to the other every two days. This assumption was made to have a reasonable amount of startup and shut down since H-ZSM-5 varied in run time (anywhere from 4 to 96 hours) before saturation in a given process. And this assumption combined with the lifecycle assumption (of at least 22 regeneration cycles) leads to replacing a single catalyst's bed once every 2 months.

Finding reliable bulk pricing for catalysts is very difficult in the same way that finding operating conditions for catalysts is difficult, but to give an idea of the cost for the catalysts a rough value was found and followed for economic evaluation (H-ZSM-5 [38] & Aluminum Oxide [39]). These values are not prescriptive, and it is recommended that catalyst specifications, operating details, and pricing be further discussed and finalized with catalyst distributors if this design were going to be implemented.

Finally, it was assumed that the temperature gain throughout both the adsorption processes was negligible for two main reasons: radiation of heat from the adsorption columns and weak bond formation with catalysts. These reactions would happen infrequently (compared to overall flow) enough and with weak enough bonds (thus releasing small amounts of energy in the form of heat) to roughly balance out with the amount of radiation each of these beds would experience.

Process Operation During Regeneration/Replacement of Catalyst

Interstitial tanks were placed prior to adsorption for both the Light and Medium cuts that allow for storage of up to 3 days of the Light or Medium cut. This amount of flexibility allows for the continual distillation of PyOil without shutting down the plant if both wings of adsorption vessels are not operating. Both wings would not be operating for any number of reasons coinciding, such as replacement of spent aluminum oxide, regeneration of H-ZSM-5, replacement of spent H-ZSM-5, regular maintenance of any of the adsorption vessels or their heat exchangers, or an event which damages one or both wings of adsorption vessels. In the event that 2 of these events happened (most commonly regeneration of one wing with the other wing having catalyst replaced) the tanks would hold liquid that would be used as soon as a single wing was operational again. An oversize factor of 10% [4] was used to all equipment in each adsorption wing to ensure it could operate at higher flow rates than the distillation tower if necessary. The oversize factor also allowed for adequate contamination removal (discussed below) and allowed a longer run time before regeneration. Alternatively, a third wing could be purchased to avoid using tanks, but the tanks would be far cheaper than an additional wing and would have a smaller footprint.

Approach to Varying Levels of Contamination

Halogen contamination is the largest problem for the PyOil fractioning and purification unit since heavy metal contamination is almost entirely found in the Heavy cut while the halogen contamination is spread between the Light, Medium, and Heavy cuts. When put through distillation around 99% of heavy metal contaminants are found in the Heavy cut (with around 0.01% of heavy metals in Light cut & around 0.36% in the Heavy cut) [33]. These cuts still must go through a heavy metal decontamination step since even in small concentrations they still cause problems for ethylene cracking, but the massive reduction in heavy metal ensures that even in times of high contamination, the heavy metal decontamination process will be able to confidently produce a clean product.

Downstream pre-treatment of the plastic feed to pyrolysis should aid our process in having a PyOil feed which does not vary wildly in contamination. While it depends on the specific construction of the pyrolysis unit, the first two treatment steps in plastics pyrolysis are usually pretreatment and a dehalogenation/dechlorination process for pyrolysis units where the final product will be fractionated for fuel. These steps are taken to remove these compounds (in combination with the de-gassing step) since they hinder the quality of the final pyrolysis oil. Some pyrolysis units don't have a dehalogenation step prior to producing PyOil, but when the final product will be fractionated for fuel, it's quite common to have dehalogenation steps before pyrolysis and after fractioning. It's required to do this to meet the decontamination requirements for being able to burn cleanly.

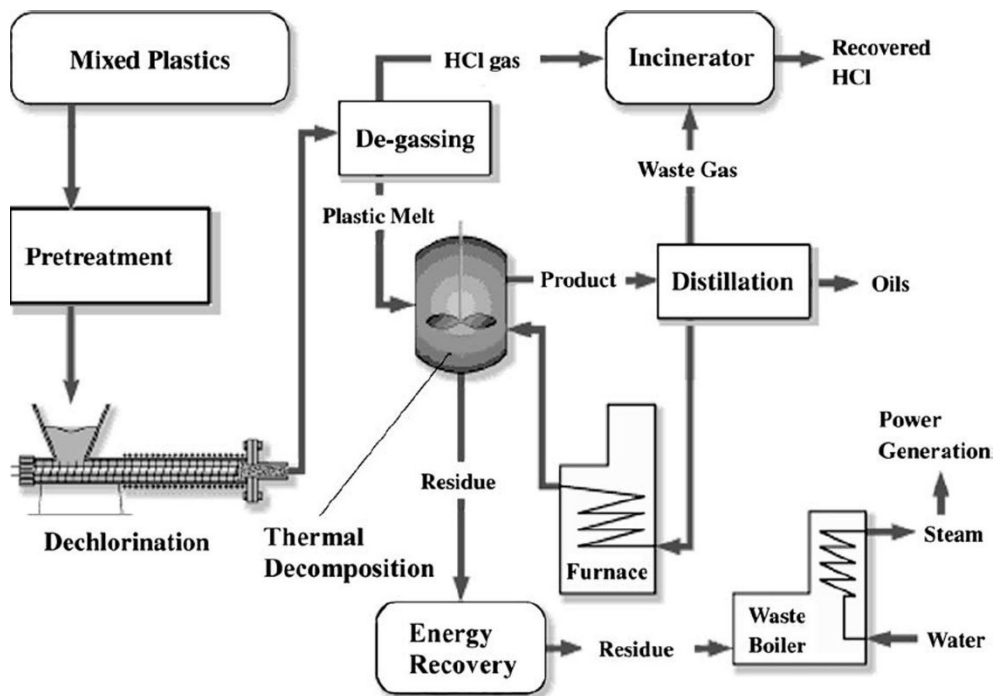

Figure 14: Pyrolysis unit in Niigata, Japan [33]

Figure 14 is an example of a pyrolysis unit operating in Niigata, Japan. The PyOil produced by this plant is fractioned into different fuels [40] and sold in a similar way to how our plant would operate. It has a pretreatment and de-chlorination step prior to thermal decomposition of the plastics. Therefore it is a fair assumption to make that there is a dehalogenation step at the pyrolysis plant which provides the feed oil for the project. With this knowledge, it seems fair to further assume when the plastics feed has lots of halogen contamination, the PyOil produced won't have an untreatable concentration of halogens.

As discussed in the assumptions, an oversize factor (of 10% [4]) was used when sizing the adsorption vessels. That oversize factor addressed multiple concerns including high contamination of the PyOil feed. This oversize factor should also help to account for this event even when a portion of the bed is spent (which would also help increase regular run time before requiring regeneration) as well as accounting for additional throughput when the process has been shut down for any reason and there has been liquid accumulation in the interstitial storage tanks.

Finally, both the feed and the products will be stored in tanks capable of weeklong hold-up. This factor will dilute contamination between batches of pyrolysis meaning that it is fair to assume a near constant amount of contamination prior to treatment, and near constant product after fractioning and treatment.

Appendix - Distillation Section Detail

Configuration and Considerations with Distillation Design

The configuration for the distillation section for the PyOil purification unit is a series of distillation towers that resemble somewhat of a fractionation unit designed to separate off the Pygas, Light, and Medium cuts respectively. The design group considered one tower for this process with an overhead vapor stream being the Pygas, the condensed liquid at the top of the tower being the Light cut, a side draw for the Medium cut, and the liquid flowing from the bottom of the tower being the Heavy cut. However, after investigating this design, the group decided that it would be too complex and costly, mostly due to the height of the tower possibly reaching a height where further cost would be assumed for considerations due to wind. Therefore, the group pursued a design with three distillation towers, working in series to simplify the process, with each tower designed to remove a single cut rather than one tower working to produce all cuts simultaneously.

The first tower, meant to separate the PyGas from the PyOil feed stream, operates with a top column pressure of 2.4 psig, as this was the specified minimum column top pressure for the PyGas stream to ensure enough pressure for two reasons given in the provided information. The first reason is that "2.4 psig pressure ensures that it (the PyGas stream) has sufficient pressure to reach the ethylene plant without the need for additional compression," and the second is that "in

the event that there is no overhead vapor distillate present in the tower overhead, the 2.4 psig specification ensures that the tower will operate without the risk of air ingress into the process” [5]. The PyGas stream also exits the tower at 107 °F so that design specifications are met, and the PyGas stream can be immediately sent to the ethylene plant without further processing. The tower includes 25 theoretical stages in order to achieve the specified separation. With a tray efficiency of 81.51%, which was found using the O’Connell correlation [41], the actual number of trays is determined to be 31 trays. The feed stage location was determined with an optimization method that is discussed below and was found to be at tray 19. Considering the pressure drop across the trays being 0.1 psi per tray [4], the pressure in the bottom of the tower was found to be 22.17 psia. The temperature in the bottom product was 423.6 °F. The tower dimensions were 72 ft tall with a 3.75 ft diameter. The height was calculated assuming a tray spacing of 2 ft with 4 ft included to consider vapor disengagement and 6 ft for the liquid level in the tower. The diameter was rounded up to the nearest quarter foot for standard sizing and costing.

The second tower was designed to separate the Light cut from the remaining PyOil mixture flowing from the bottom of the first tower. This tower was designed to operate as an atmospheric column with a column top pressure of 15.2 psia to ensure that any pressure drop due to frictional losses would not cause two phase flow. The Light cut overhead vapor stream had a temperature equal to the cut’s end boiling point when adjusted from 392 °F at atmospheric pressure to 394.3 °F at 15.2 psia to ensure the capture of all hydrocarbons that should be incorporated into the Light cut. The tray efficiency of this tower was assumed to be less than the efficiency of the trays in the first tower because there are heavier hydrocarbons being separated so the group decided to estimate the efficiency of the tower trays at 65%. This value was chosen because it fits within a heuristic that the tray efficiencies for distillation of light hydrocarbons are anywhere between 60-90% [4], and because this seemed like a fair estimate for hydrocarbons that are heavier. With this estimate for tray efficiency, and following the optimization technique presented below, the number of trays for this tower was 42 with a feed tray location at tray 20. The pressure and temperature at the bottom of the column were 21.35 psia and 532.5 °F. The Light cut tower dimensions were 94 ft tall with a diameter of 3.75 ft with the same assumptions and considerations involved in sizing the first tower.

The third and final distillation tower separates the Medium cut from the remaining PyOil mixture, which is identified as the Heavy cut following the separation in this tower. This tower operates at a top pressure of 15.2 psia, the same pressure as the Light cut tower, and a temperature of 488.4 °F. The end boiling point given, 620 °F at 70 psig, was adjusted to 488.4 °F at a pressure of 15.2 psia so that the Medium cut is comprised of the hydrocarbons it should be. The tray efficiency was estimated to be 50%, which is another 15% step down in efficiency from the second tower. This was estimated by the same reasoning that the tray efficiency in the second tower was estimated but applied to the separation occurring in the final tower, with even heavier hydrocarbons. Considering this efficiency and optimization of the tower, the number of trays for this tower was 38 trays with a feed tray location at tray 8. The Heavy cut flowing from the bottom of this tower had a pressure and temperature of 21.0 psia and 627.7 °F. The Medium cut

tower had a height of 86 ft and a diameter of 3.75 ft with the same assumptions and considerations as the previous towers.

Distillation Design Assumptions

The main assumption that the group utilized in the design of each tower was specifying a component of the respective feed stream that would be 100% recovered in the top product. The assumption was that the lightest component of each inlet stream would be 100% recovered in the overhead vapor stream exiting the column as a product. This assumption was further supported by the specification that each overhead vapor stream exiting the column will be exiting at the end boiling point of whatever cut is desired. This supports the assumption about recovery percentage because the cut stream temperatures specified are much higher than the boiling points of the components used for the recovery specification. For example, in the second tower of the design, the Light cut is separated by a specification of 100% recovery of N-hexane, which was the lightest component in the inlet stream to the second column, and the Light cut stream was specified to be at 394.3 °F, the end boiling point of the Light cut stream. This was done for the Medium cut as well, specifying a 100% recovery of the lightest component in the inlet stream, which was entirely comprised of pseudo-components, and a temperature of 488.4 °F. Regarding the PyGas, however, the end boiling point of the mixture was not provided and can be assumed to be significantly lower than the feed inlet temperature, so the stream temperature of the PyGas in the vapor outlet of the first column was assumed to be the given product specification temperature, 107 °F.

In the case of the PyGas stream, methane was assumed to be 100% recovered in the PyGas vapor outlet stream. Another assumption the group made upon designing a solution was that boiler feed water is available on site for the group to utilize in waste heat boilers and the primary condensers on the distillation towers because of the great difference in temperatures. Because of this assumption, steam generation is possible in the design and is credited towards the design as value added to the design by equating steam generated to a utility cost that is subtracted from the overall variable cost in the design. Boiler Feed Water was assumed to be supplied for the design at 80 °F and 50 psig to account for heating up the water from ambient temperature and producing low pressure steam at a temperature of 298 °F and 50 psig.

Additionally, it was assumed that the Heavy cut could be split into barge oil and untreated coking products based on studies [34] where the further fractionation of the Heavy cut would reclaim a portion of the Heavy cut which can still be used for fuel in large diesel engines (likely blended in with other heavy fuel oils). The last portion of the Heavy cut contains the most contamination (heavy metals, fine solid particles, byproducts of component interactions & polymerizations) making this section the most viscous and difficult to further decontaminate or reclaim burnable fuel from. This portion of the Heavy cut can still be used as coking material [34], but design and implementation of a coking process is outside of the scope of this project, so it was decided to sell this material as is.

Approach to Optimization and Minimizing Consumption

As each tower was designed, they were optimized to minimize the reflux ratio through altering the number of theoretical stages and feed stage location. This was done by testing a certain number of stages, altering the feed stage location until the reflux ratio was at a minimum, and then comparing the value obtained from multiplying the number of stages with the reflux ratio to other values obtained through the same method of minimizing the reflux ratio at a certain number of stages with varying the feed stage location. Graphing these results on a number of stages versus number of stages multiplied by reflux ratio basis yields a graph with the optimal tower having a number of stages that is presented by the minimum value for number of stages multiplied by reflux ratio. A graph of the optimization results using this method for the Medium cut tower in the design is presented below.

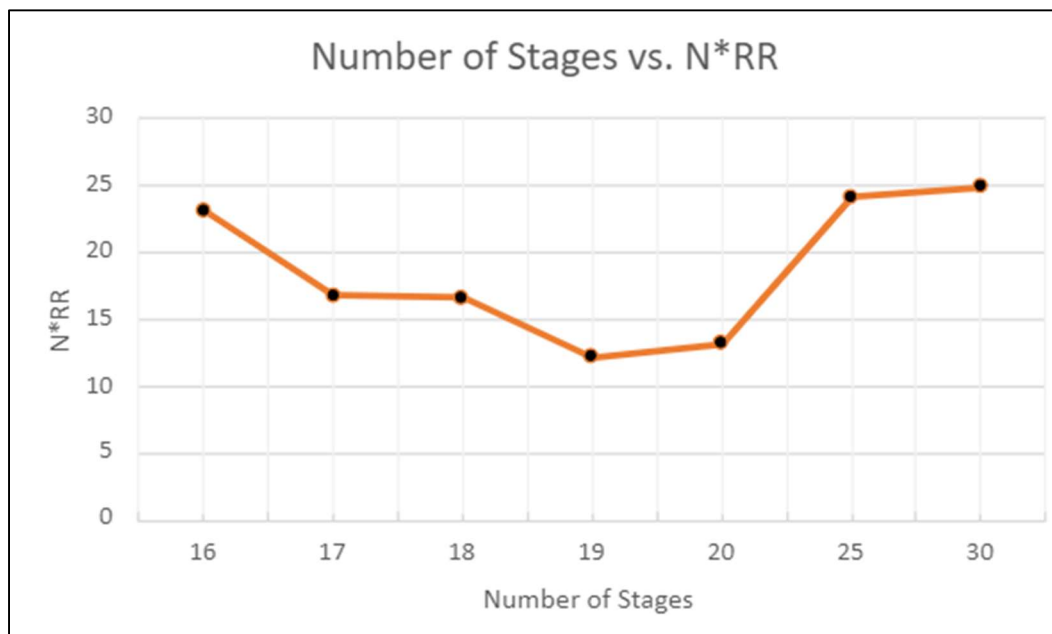

*Figure 15: Number of Stages vs. N*RR for Medium Cut Tower (T-103)*

As previously discussed, using this data obtained from minimizing the reflux ratio will yield a number of stages that should be utilized for the most efficient tower design. In this case, the minimum N*RR value yields a number of stages of 19, therefore, the tower designed for the Medium cut separation was designed with 19 stages. This same approach to optimization was followed for the PyGas and Light cut towers as well. Because of this method of optimization, the tower is designed to require the least amount of energy possible for the process it is undergoing since the reflux ratio, and therefore material continuously requiring heat input and output is minimized. This also increases the throughput of the towers.

Also, as part of the distillation unit, overall energy consumption is lessened due to the use of a pre-heater for the PyOil feedstock to heat up the feed before entering the first tower of the distillation unit. Energy consumption is lessened as the already hot Heavy cut is utilized in the heat exchanger to allow waste heat to pre-heat the PyOil feedstock, and therefore remove some heat duty off downstream processes, with the most effected equipment being the reboiler on the first distillation tower.

Distillation Method of Control

Control over the column was attained through the use of seven control systems around the column, condenser, kettle reboiler, and condensate reflux drum. For the column, level control was achieved through monitoring the tower liquid level and manipulating the bottoms flow to the kettle reboiler, and pressure control through the monitoring of the pressure of the vapor leaving the tower and manipulating the untreated Light cut vapor flow rate. That level control valve was set to fail open to remove liquid from the column in the case of emergency, and the pressure control valve was set to fail close to prevent vapors from continuing to flow.

The condenser process outlet temperature was controlled through the boiler feed water inlet flow rate with the control valve set to fail open to ensure continued cooling of the vapor. Liquid level on the condensate reflux drum was controlled by the reflux rate to the column, and this valve was set to fail open so that the drum would not fill with liquid.

The kettle reboiler had three control systems which were pressure, temperature, and level. The level was controlled through the flow of the liquid outlet stream with the control valve set to fail close to prevent the excess liquid from going to the next tower.

The pressure is controlled through the boil up flow to the tower, and that valve is set to fail open to ensure that the pressure does not remain isolated in the reboiler. The temperature of the bottoms stream and thus the reboiler is controlled through the hot oil inlet stream with that valve being set to fail close so that the liquid that will build up in the reboiler will not continue to heat up.

Considerations for Removal of Free Water

Many factors contribute to having a water free Light and Medium cut. The initial pyrolysis will have a drying and moisture removal step that will limit water prior to pyrolysis since moisture content severely limits the amount and quality of PyOil from pyrolysis (42). Most moisture that is present in the feed during pyrolysis will be removed or converted to unwanted byproducts by the process, leaving a relatively low amount of water in the resulting PyOil.

The dehalogenation process that occurs in the second adsorption step will also limit water in the final product. The dehalogenation catalyst H-ZSM-5 should remove small amounts water

left in the Light and Medium cuts when dehalogenation is occurring [43]. It was considered if a coalescer should be added after the adsorption processes for both the Light and Medium cut, but it was deemed unnecessary due to the previous steps above and the high likelihood of frequent maintenance. The filter would likely quickly clog from fine particles in solution and would require frequent maintenance or replacement making the benefit of having a coalescer negligible.

Tray Design & Rationale

For the first tower, the group selected bubble cap trays as these can be “designed for lower pressure drop than sieve or valve trays” [4]. The lowest pressure drop in that occurs in the three towers occurs in the first tower that separates the PyGas, so the group thought that bubble cap trays were appropriate for application in the first tower.

For the remaining two towers, sieve trays were selected as the type of tray to be utilized as these are the cheapest tray type available and would still achieve the desired separation in these towers.

Temperature and Vapor/Liquid Traffic Profiles in the Tower

The temperature and vapor/liquid traffic profiles of each tower are given below in Figures 16-24. It is worth noting that for each vapor/liquid traffic profile, a blue bar indicates flow that is desirable in the column, whereas a yellow bar indicates warnings associated with the vapor or liquid traffic at a specific theoretical stage in the column. These warnings were considered negligible in the case of this preliminary design, but these warnings would be addressed in the detailed design stage of this project if the project were to continue to an analysis of detailed design.

Figures 16-18 Are related to the first distillation tower in the process, T-101. The temperature profile here ranges the smallest temperature values in comparison to the other temperature profiles for towers T-102 and T-103. The vapor and liquid traffic that is experienced in T-101 is also the smallest in flow compared to the other towers, and this is evidenced by the vapor and liquid traffic profiles relating to each tower.

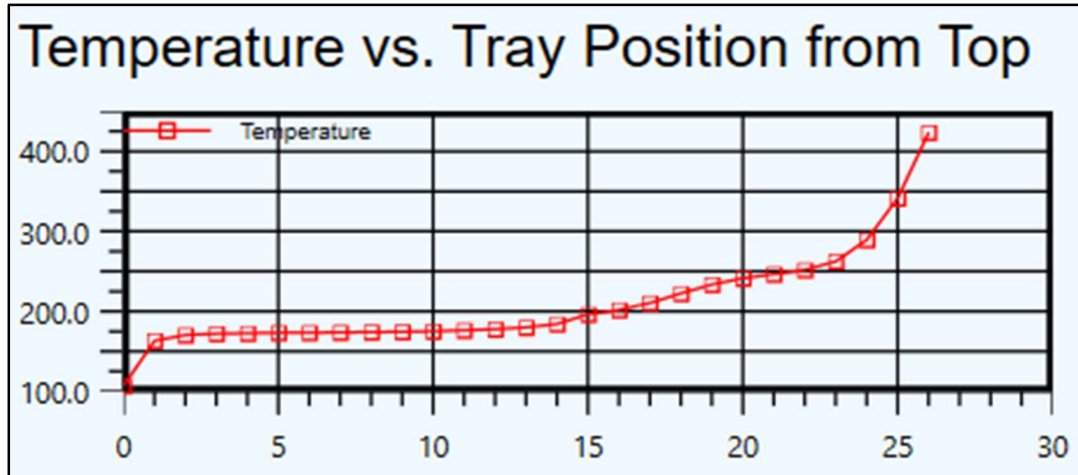

Figure 16: Temperature Profile for T-101

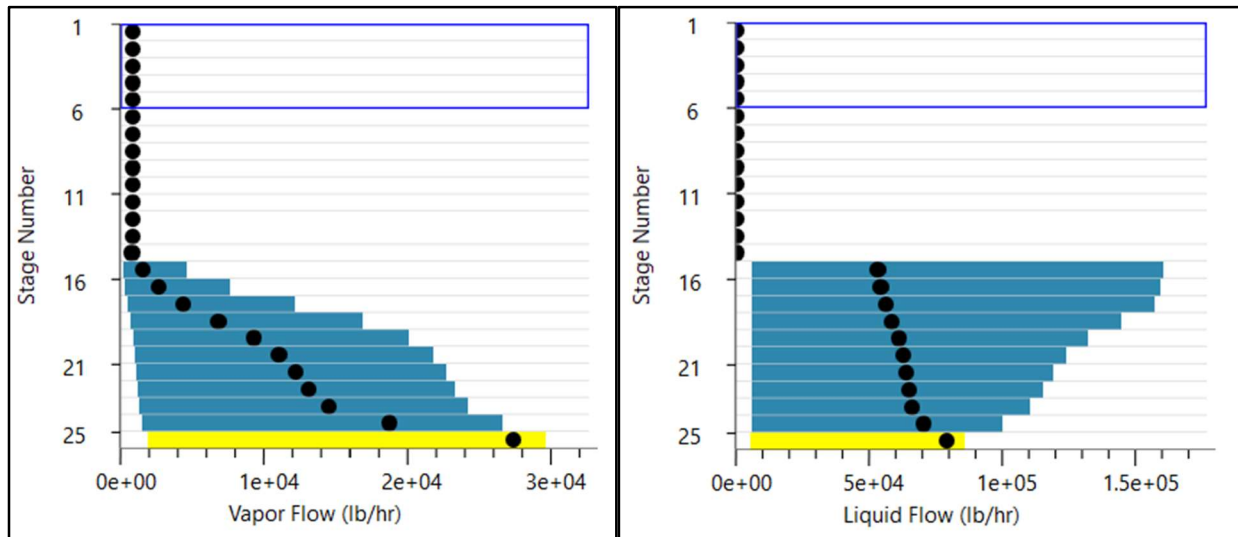

Figure 17: Vapor Flow Traffic Profile for T-101 & Figure 18: Liquid Flow Traffic Profile for T-101

The following temperature and vapor/liquid profiles in Figures 19-21 are related to the Light cut tower, T-102. The temperature profile associated with T-102 follows a similar trend to the temperature profile of T-101, but with a higher temperature range. This tower experiences the greatest amount of liquid flow traffic in comparison with T-101 and T-103. Up to stage 12 of T-102, the liquid flow traffic is much less than in the stages following while the vapor flow traffic slightly decreases to this stage and then greatly increases in the following stages.

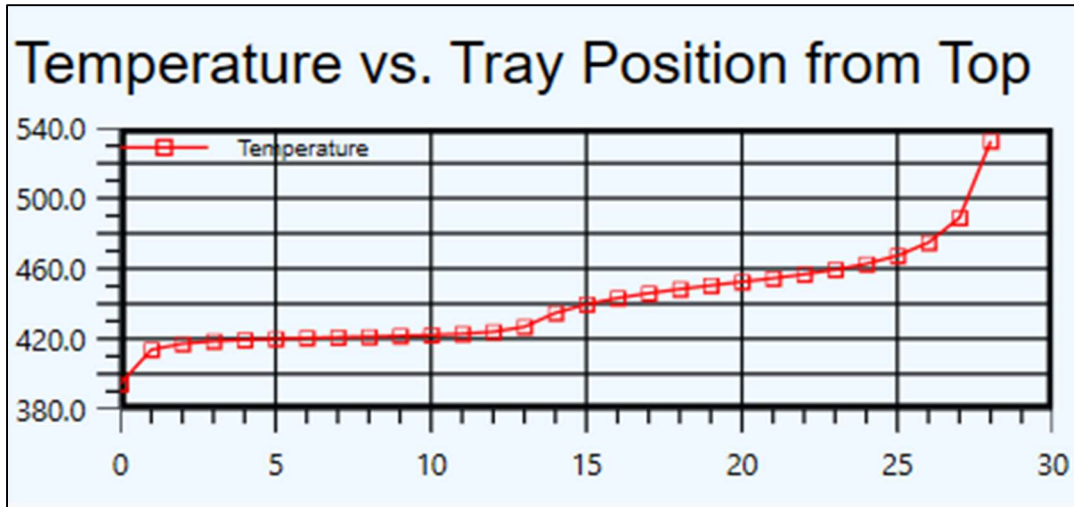

Figure 19: Temperature Profile for T-102

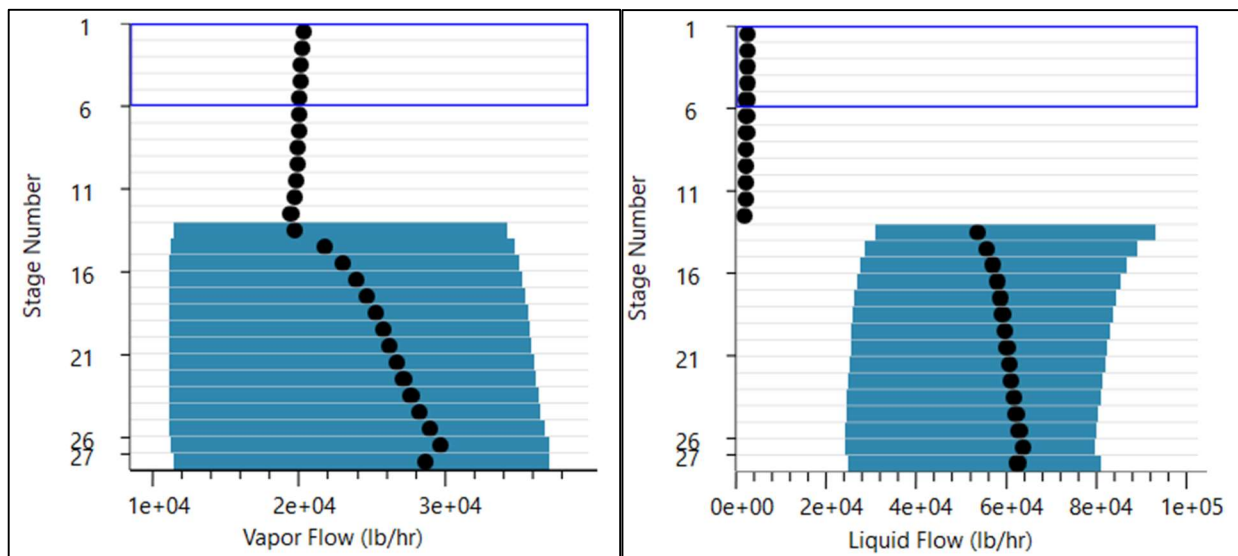

Figure 20: Vapor Flow Traffic Profile for T-102 & Figure 21: Liquid Flow Traffic Profile for T-102

Finally, the temperature and vapor/liquid profiles of the Medium cut tower, T-103, are given below in Figures 22-24. The temperature profile in this tower is unlike the profiles of the other towers and possesses a much smoother curve in regard to its profile. T-103 also experiences the highest vapor flow traffic in comparison with T-101 and T-102. The vapor and liquid traffic flow profiles also provide blue bars on each stage of the tower meaning that T-103 has the greatest accuracy in its analysis of the separation specified in this tower.

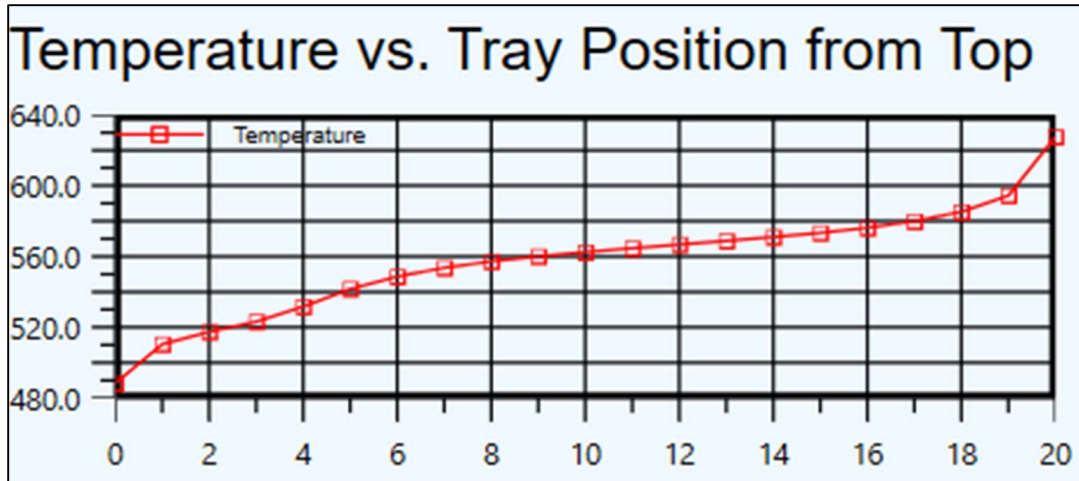

Figure 22: Temperature Profile for T-103

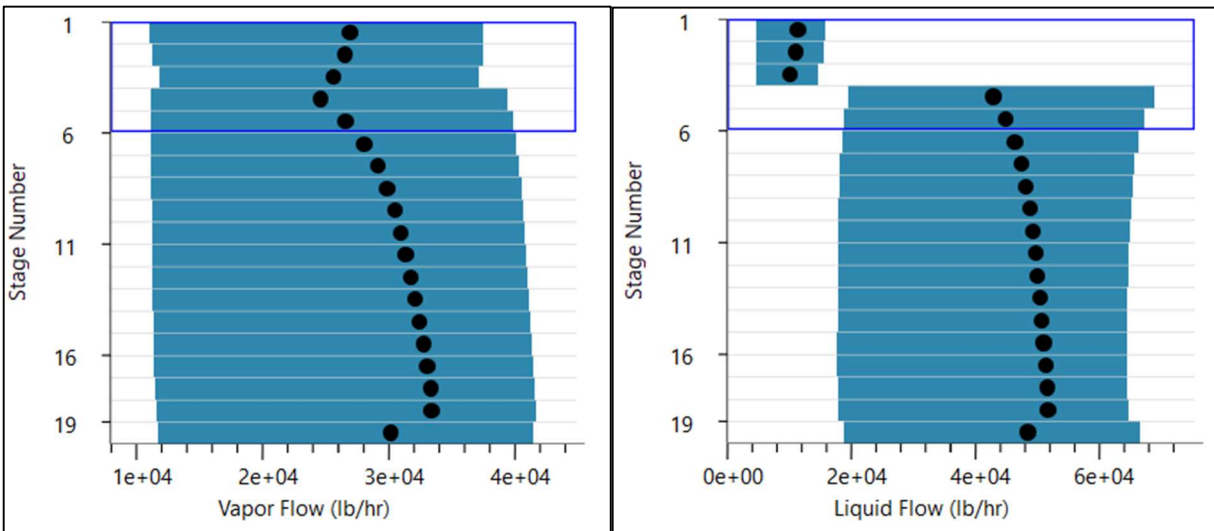

Figure 23: Vapor Flow Traffic Profile for T-103 & Figure 24: Liquid Flow Traffic Profile for T-103

References

- [1] - Ritchie, H., and Roser, M. (2018, September 1) Plastic Pollution. Our World in Data.
- [2] - Machado, J., Miksiewicz, E., and Yeo, G. (2023, January 17) 2022 – 2023 Part 2 Background and Technical Information: Closing the Circularity Gaps for a Manual Waste Sorting Facility that provides feedstock to a pyrolysis unit. AIChE.
- [3] – Machado, J., Miksiewicz, E., and Yeo, G. (2023, January 17) 2022 – 2023 Student Design Competition Problem Statement & Rules. AIChE.
- [4] - Turton, R., Shaeiwitz, J. A., Bhattacharyya, D., and Whiting, W. B. (2018) Analysis, Synthesis, and Design of Chemical Processes. Prentice Hall Boston, MA.
- [5] - Machado, J., Miksiewicz, E., and Yeo, G. (2023, January 17) Part 1 Background and Technical Information: Design of a Pyoil Purification Unit for Supply of Recycled Feedstock to a Steam Cracker. AIChE.
- [6] - Boiler efficiency. *Boiler Efficiency - an overview | ScienceDirectTopics*.
- [7] - Engineer salary in Singapore - average salary. *Talent.com*.
- [8] – Promise to Preform Industries. (2021, July 16) Stainless Steel vs. Galvanized Steel. *Rigid Lifelines*.
- [9] - Solenoid directional valves type SDKE.
- [10] - Process Safety and Environmental Protection Volume 91, Issues 1–2, January–March 2013, Pages 61-78 - Received 21 September 2011, Revised 11 January 2012, Accepted 11 February 2012, Available online 18 February 2012. - Kamarizan Kidam, Markku Hurme
- [11] and Human Error - By Trevor A. Kletz, Paul Chung, Chaim Shen-Orr
- [12] (2019, July 12) Chemical reactivity worksheet. *AIChE*. Center for Chemical Process Safety.
- [13] - (2018, February 1) 1,3-Butadiene - Safety Data Sheet - Airgas.
- [14] - (2018, January 31) 1-Butene - Safety Data Sheet - Airgas.
- [15] - (2020, January 6) Butane - Safety Data Sheet - Airgas.
- [16] - (2018, February 12) Carbon Dioxide - Safety Data Sheet - Airgas.
- [17] - (2020, November 5) Carbon Monoxide - Safety Data Sheet - Airgas.
- [18] - (2017, July 3) Cis-2-Butene - Safety Data Sheet - Airgas.
- [19] - (2021, July 15) Ethane - Safety Data Sheet - Airgas.
- [20] - (2021, June 3) Ethylene - Safety Data Sheet - Airgas.

- [21] - (2021, February 22) Hexane - Safety Data Sheet - Airgas.
- [22] - (2020, November 15) Hydrogen - Safety Data Sheet - Airgas.
- [23] - (2018, May 10) Isobutylene - Safety Data Sheet - Airgas.
- [24] - (2020, November 15) Methane - Safety Data Sheet - Airgas.
- [25] - (2021, August 31) Nitrogen - Safety Data Sheet - Airgas.
- [26] - (2021, February 22) Pentane - Safety Data Sheet - Airgas.
- [27] - (2020, November 15) Propane - Safety Data Sheet - Airgas.
- [28] - (2020, November 15) Propylene - Safety Data Sheet - Airgas.
- [29] - (2019, June 26) Trans-2-Butene - Safety Data Sheet - Airgas.
- [30]- Zipf, R. K. Effects of Blast Pressure on the Human Body - Centers for Disease
- [31] - Gent, R., Menendez, M., Torano, J., and Torno, S. (2011, January 17) Optimization of the Recovery of Plastics for Recycling by Density Media Separation Cyclones. Resources, Conservation, and Recycling. Elsevier.
- [32] - Zhang, Q. S., Zhang, Z. S., Yang, X. H., Yang, Z., and Yang, L. Y. Simulation and Optimization Design of Cyclone Separator for Waste Plastic Film. IOP Science.
- [33] - Kusenberg, M., Eschenbacher, A., Djokic, M., Zayoud, A., Ragaert, K., Meester, S., and Van Geem, K. (2021, December 3) Opportunities and Challenges for the Application of Post-Consumer Plastic Waste Pyrolysis Oils as Steam Cracker Feedstocks: To Decontaminate or Not To Decontaminate? Waste Management. Pergamon.
- [34] - Belbessai, S., Azara, A., and Abatzoglou, N. (2022, April 11) Recent Advances in the Decontamination and Upgrading of Waste Plastic Pyrolysis Products: An Overview. MDPI. Multidisciplinary Digital Publishing Institute.
- [35] - Sivagami, K., Kumar, K. V., Tamizhdurai, P., Govindarajan, D., Kumar, M., and Nambi, I. (2022, March 8) Conversion of plastic waste into fuel oil using zeolite catalysts in a bench-scale pyrolysis reactor. *RSC advances*. U.S. National Library of Medicine.
- [36] - Baghapour B., Rouhani M., and Sharafian A. (2018, March 31) A pressure drop study for packed bed adsorption thermal energy storage. *Applied Thermal Engineering*. Pergamon.
- [37] - Recycle and reuse of natural zeolites from composting process: A 7-year project. *Taylor & Francis*.
- [38] - H-ZSM-5. *Riogen - Catalysts for Chemicals & Energy*.
- [39] - Alerts, I. Aluminum oxide prices - historical & forecast data in several countries. *Intratec.us*.

- [40] - (1998, March) Liquification Technology. PWMI Newsletter. Plastics Waste Management Institute.
- [41] - Duss, M., and Taylor, R. (2018, July 10) Predict Distillation Tray Efficiency. AIChE.
- [42] - Eke, J., Onwudili, J. A., and Bridgwater, A. V. (2019, May 4) Influence of moisture contents on the fast pyrolysis of Trommel fines in a bubbling fluidized bed reactor - waste and biomass valorization. *SpringerLink*. Springer Netherlands.
- [43] - Ratnasari, D. K., Bijl, A., Yang, W., and Jönsson, P. G. (2020, August 3) Effect of H-ZSM-5 and al-MCM-41 proportions in catalyst mixtures on the composition of bio-oil in ex-situ catalytic pyrolysis of lignocellulose biomass. *MDPI*. Multidisciplinary Digital Publishing Institute.