

Automated X-Ray Imaging System of Peanut Smut Disease

Kelly Lewis, Dept. of Biosystems & Agricultural Engineering and Samuel Li, Dept of Mechanical Engineering

Abstract

The practice of hand-opening pods for rating disease is a major bottleneck in breeding for peanut smut resistance. An x-ray imaging system is being developed at the BAE department the goal of speeding up the disease rating process for peanuts. We were targeting the design and development of the enclosure of the x-ray imaging system and the control system for operating the x-ray imaging system.

Introduction

Peanut smut, caused by the fungus *Thecaphora Frezzii*, replaces peanut kernels with fungal spores. It has been found in South America, such as Argentina, Bolivia, and Brazil.



Fig 1. Peanut seeds at levels of smut disease

The peanut research community has been developing commercially acceptable smut-resistant cultivars. However, there are significant roadblock to screening for resistance. Hand opening requires:

- Training in phenotyping germplasm
- Evaluate severity and absence / presence
- Time consuming

Soft X-ray imaging is a non-destructive alternative technique that has potential for detecting peanut pod with smut disease seeds. The x-ray images have been used to analyze internal structure of many objects. For peanuts, healthy pods are denser than infected pods with *Thecaphora Frezzii* teliospores.

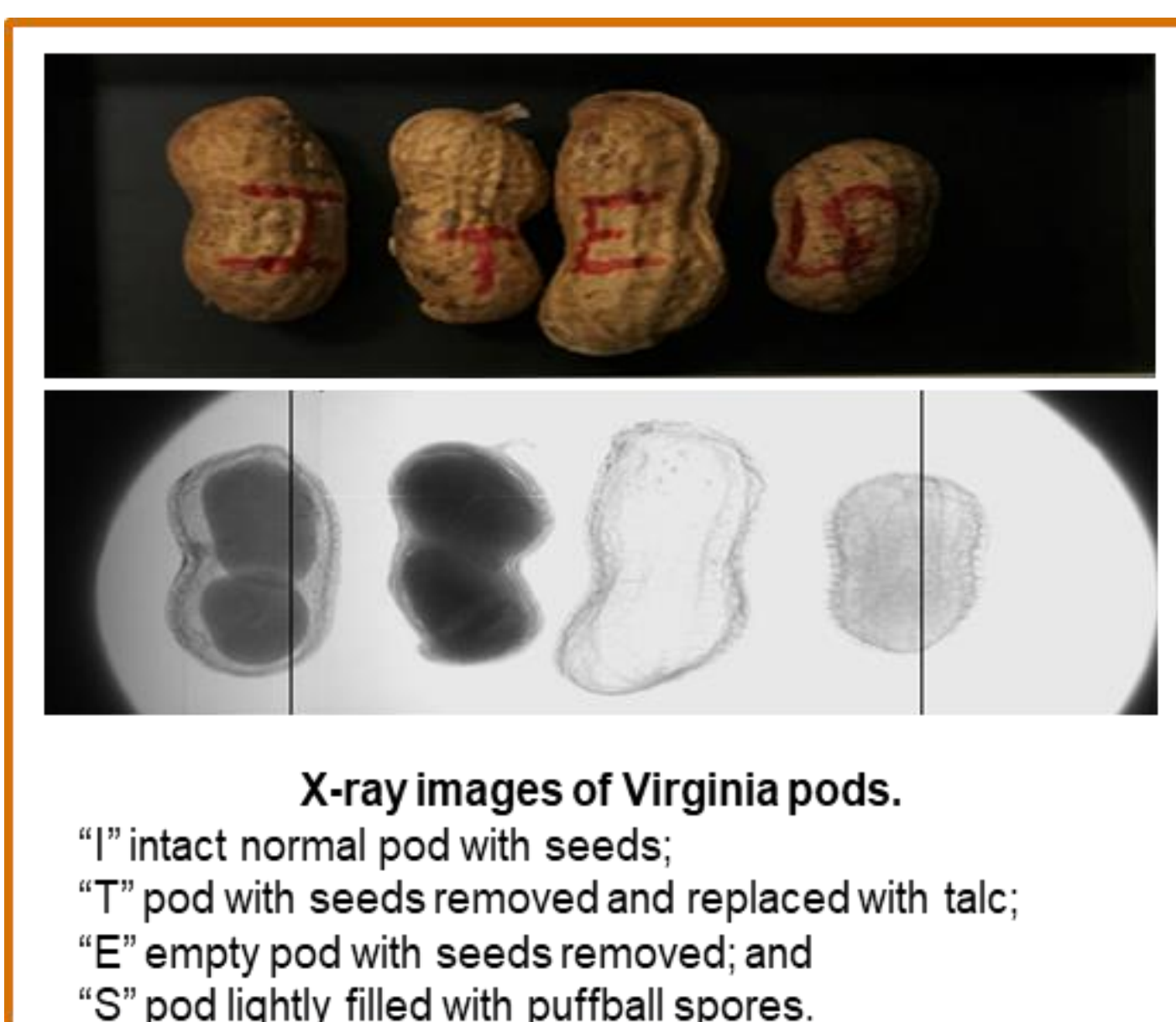

Fig 2. Peanut pods and their relevant x-ray images

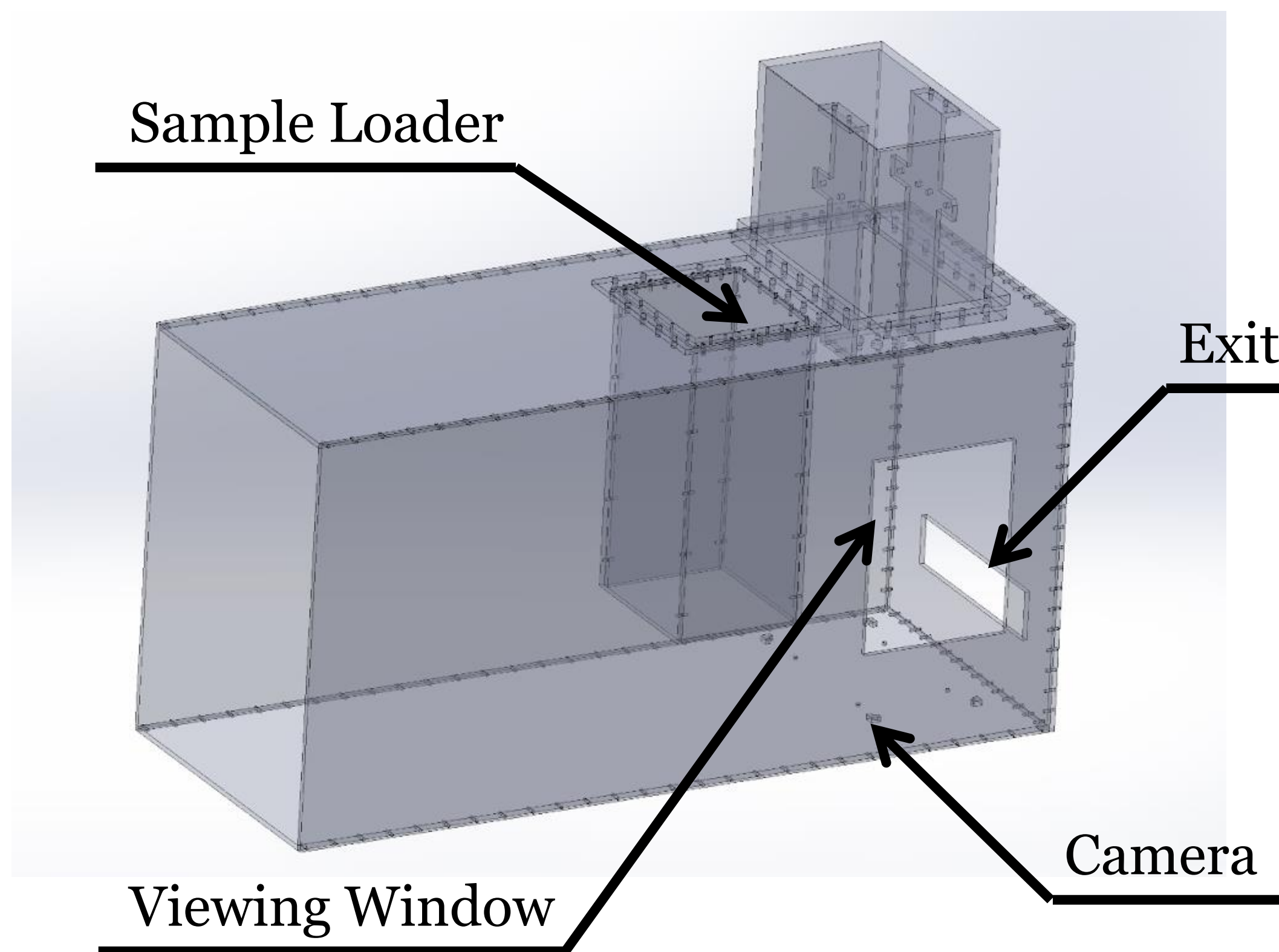

Fig 3. Solid Work Design of the Enclosure for the X-Ray Imaging system

Design Considerations

- Lead lining with lead acrylic windows
- Limit switches to ensure closed doors
- Fan for cooling x-ray tube
- Thermistor to monitor temperature of X-ray tube
- Line scan camera and actuator for collecting images
- Top-down loading for ease of batch samples



Fig 4. Back View Assembled Enclosure for X-Ray System

Design Constraints

- Safety
- No unsealed exits
- Max operating temperature
- Automatically perform many samples
- Lead lining

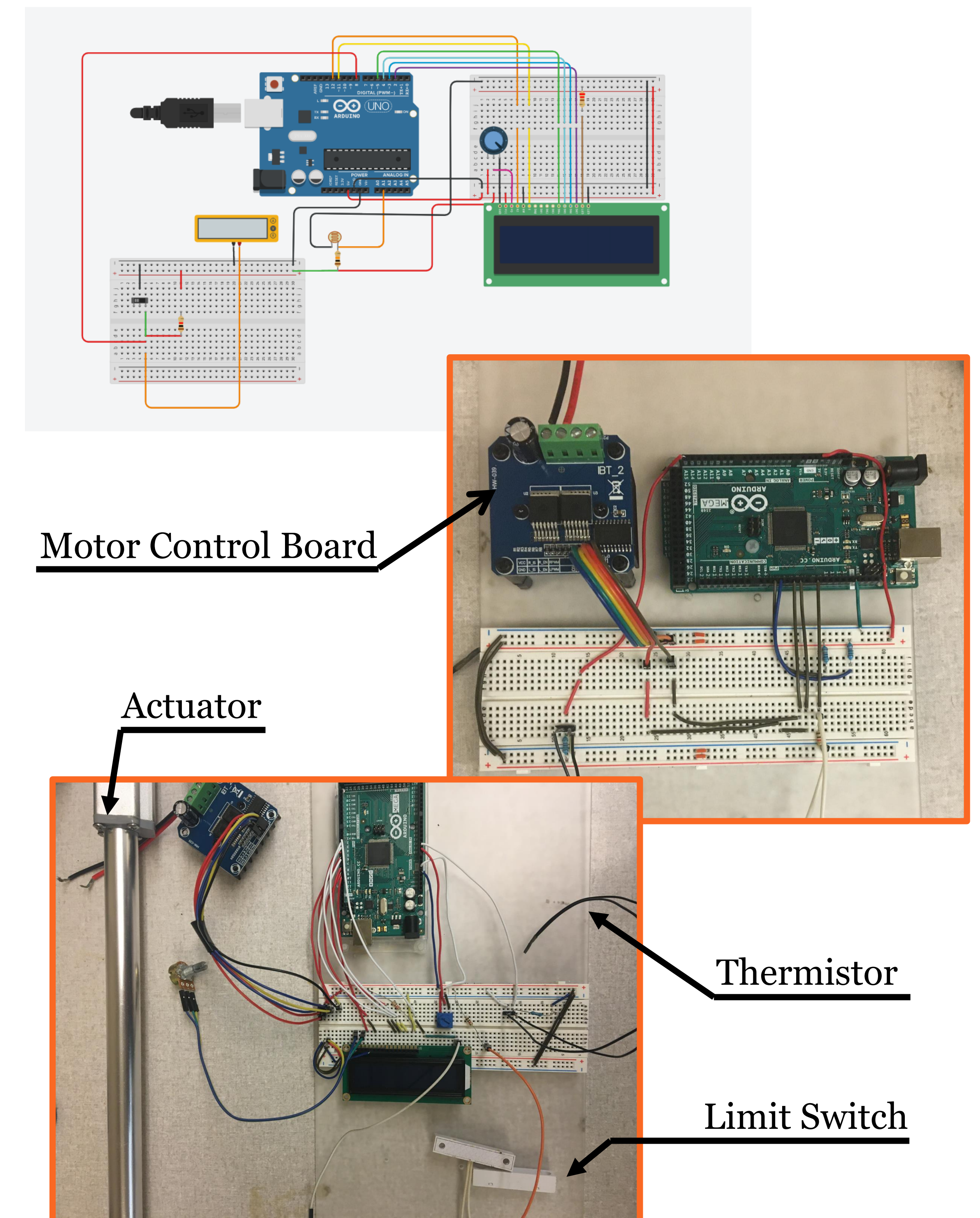

Fig 5. Circuit Development of Control System

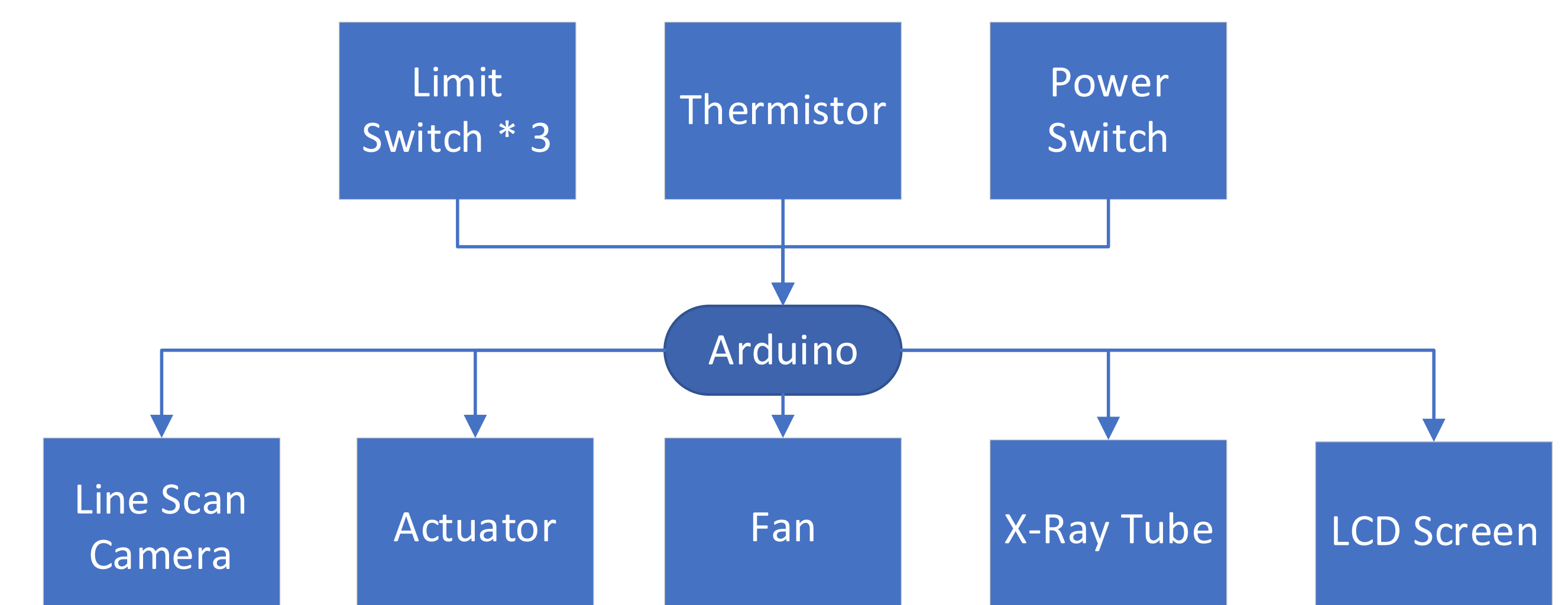

Fig 6. Block Diagram of the Overall Control System

Acknowledgments:

A special thank you to Dr. Ning Wang of the Biosystems and Agricultural Engineering Department and Dr. Bennett of the USDA Agricultural Resources Services.