



RUG MAKING IN THE FARM HOME

Circular No. 373

1940

**COOPERATIVE EXTENSION WORK
IN
AGRICULTURE AND HOME ECONOMICS
State of Oklahoma**

ERNEST E. SCHOLL, Director

Oklahoma Agricultural and
Mechanical College and
United States Department of
Agriculture, Cooperating

Extension Service
County Agent Work
Stillwater, Oklahoma

*Distributed in Furtherance of the Acts of Congress
of May 8 and June 30, 1914*

RUG MAKING IN THE FARM HOME

Thelma Greenwood, Ass't. Extension Economist, Home Management

Rug making represents a native handcraft that has been handed down from our early American settlers. Yet at no time in history has it gained the popularity that it has today. "Thrift is using what you have" may have been the original cause for its revival because the materials needed for a homemade rug are usually already in the home. Yet the real reason for its present popularity is the homemaker's urge for self-expression in a creative art. She is able to express her own originality in size, shape, design, and combination of colors in a useful and durable home furnishing.

History reveals many romantic and interesting facts regarding the beginning of rug making in the home. Wall paintings in the Egyptian tombs picture women weaving in the home, and writings of the early historians mention rugs as home furnishings.

Many of our first American settlers were too poor to bring rugs from the mother country. First through necessity, but soon through the joy of creating beauty with the drab things about them, they made floor coverings to keep out the cold and add attractiveness to their colorless rooms. Their rug materials were the usable parts of worn clothing, blankets, and small scraps. Of course the original colors of these materials were dulled and softened by use, and were ideal for rug colors. Then too, these early settlers wore only dark colored clothing, making it possible to have the amount of dark and deep colors that is necessary for a rug without having to dye them. When one of these early rug makers wanted to brighten the color of an old garment she made a native dye of the bark, leaves, or roots that she had gathered from plant life at hand. Her rugs cost only her energy and time, and that is all that they should cost the homemaker today.

If a rug required a design, she or one of the family made one by studying the life about them. Leaves, flowers, animals, circles, diamonds, and squares were used. As few were artists the results were more conventional than naturalistic, and were therefore the designs that we admire most today.

FACTORS TO CONSIDER BEFORE MAKING ANY RUG.

1. Each homemaker should spend a little time in deciding whether her spare time should be spent with rug making or whether some other leisure-time activity would bring more happiness to her family.

2. The materials used in making rugs should be those already on hand in the home.

3. The rugs made of only one kind of material, as all wool, all silk, or all cotton, will wear evenly all over the surface.

4. The material on hand will determine the type of rug made as some materials are not suitable for all types.

5. The rug colors should be carefully planned to fit into the room color scheme.

6. The colors should be grayed in order to make them soft and rich, but never intense or drab.

7. The different areas of color should be so planned that they will show neither contrast in light and dark, nor in brightness and dullness.

8. Since light colored rugs soil easily they are never practical unless made of washable materials. Light colors are suitable only for bedroom floors or as bath mats.

9. Larger rugs are more usable than small ones, but of course their proportion should be in relation to the furniture with which they are grouped.

10. Rugs should be heavy enough to lie flat on the floor.

11. Rectangular or oval rugs are more harmonious with the shape of the room and with the pieces of furniture than square or oddly shaped rugs.

12. Designs should be chosen to conform and strengthen the shape of the rug.

Whether to use the material on hand for a rug or to use in some other way the time and energy necessary for rug making is a personal problem for each homemaker to decide. Many homemakers gain much enjoyment from creating something with their hands, so to them rug making is a pleasant recreation. One Oklahoma rug maker said, "If my family didn't remind me, I would forget to cook the meals as I do not realize that I am hungry when I am working on a rug." Others, who consider the activity a more difficult piece of work than some of their regular homemaking tasks, should find some other means of expressing their creative desires, because rug making will not contribute the happiness it should to them or their family

RUG MATERIALS

The rug materials on hand will be old woolen garments, woolen blankets, cotton blankets, cotton garments, outing flannel, old sheets, burlap bags, knit undergarments, and silk or rayon hose. The same kind of material—all wool, all silk, all cotton or all burlap should be used throughout the rug in order that it will look the same all over and wear evenly. The strips should be cut in varying widths in order that they will be of the same weight and strength. It is wise to discard too badly worn materials or those that are not soft and pliable, because they do not justify the time and energy spent in making a rug.

The width of the strip should be such that it will give the weight that a rug needs to keep its shape and remain in place on the floor. Of course, wool is preferable to any other material because it has more weight. Then, too, there is more wear left in old woolen garments and the rug will be more durable. Wool also keeps its beauty longer and can be dyed soft, deep colors that stay beautiful even when dulled by use. Since wool is a pliable material it is the best fabric to use for braided rugs and hooked rugs.

Burlap has many of the same qualities of wool in that it is heavy and can be dyed the same rich colors but the colors fade more readily. It is less pliable than wool but will make a firm, smooth braided rug or a hooked one. The latter is more attractive when ravelings of burlap are used for the loops.

Cotton and linen rugs launder easily but they also soil more quickly. Very heavy cotton fabrics, as denim, corduroy, sheeting, etc., can be used for braided rugs, but most cottons adapt themselves more readily to crocheted rugs than to any other type.

Silk and knit garments are too soft and light in weight to be used alone for rugs. They may be hooked into a burlap base and made into a satisfactory hooked rug because the burlap helps to give weight and holds the rug in shape on the floor. Silk also takes the color of the dye bath and holds the color well. The lustre of the silk fabric adds a rich quality that is very desirable in rooms with lovely furnishings.

DETERMINING THE AMOUNT OF MATERIALS NEEDED

The amount of material needed for a homemade rug varies according to the type of rug made, the weight and the kind of material used and the number of colors used in the rug. Of

course the more colors in the rug, the more pounds of material will be required because ample allowance will have to be made for each of the different colors.

The *approximate* number of ounces of material required for each square foot of the different types of rugs is as follows:

- Hooked—8 ounces
- Braided—8-10 ounces
- Crocheted—8-10 ounces
- Woven—7-9 ounces
- Toothbrush handle—10-12 ounces

RUG COLOR SCHEMES

The colors of the rug should be selected and planned so they will fit into the room color scheme. They may either repeat or harmonize with the room colors.

A rug should give an appearance of stability to the floor and therefore fairly dark colors are necessary. This does not mean that the coloring should be dull or uninteresting because dark colors can have a depth and richness that light or drab ones never have. *It is a safe rule to say that at least three-fourths or two-thirds of the rug materials should be neutral or deep colors.* These colors should form the rug background. Neutral or deep colors may range from tan to brown and gray to black; dull blues, greens, or wine also fall in this color group. The other fourth or third of the rug colors add the contrast and variety that prevents the rug from being sombre. Even these lighter and brighter colors are grayed. Therefore pink becomes rose, green becomes sage, and blue becomes delft blue.

Rug colors are grayed by adding gray to them or by adding a small quantity of the color opposite them on the color chart. For example, blue becomes soft powder blue when either gray is added or when a small amount of orange is added.

The inexperienced rug maker may be afraid to venture forth for fear she is too daring in her choice of colors, but with a little study and color theory she will soon acquire confidence.

Monochromatic color schemes. The less daring may prefer to use this one-color harmony and vary it in value by using light tints and dark shades of one color or varying it in intensity by using grayed and bright combinations. Examples are light, medium, and dark blue or tan, cream and brown.

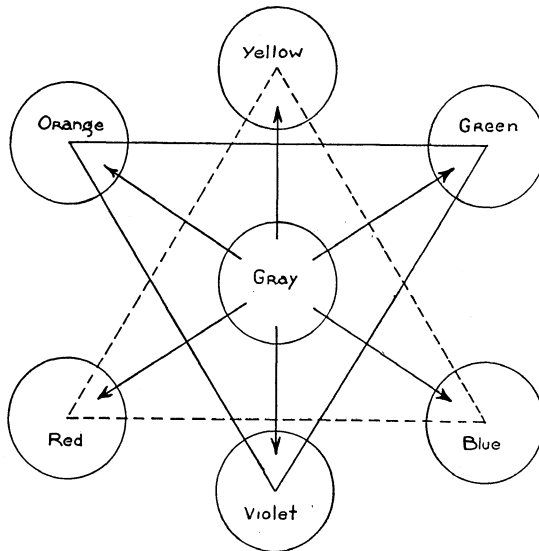

Fig 1—Color Chart

Triad color schemes include more colors and of course are more difficult to combine but are always more interesting. This three-color harmony is the combination of those colors found at the points of the triangle on the chart grayed to the soft tones necessary for floor coverings. Yellow, red, and blue are grayed to a soft tan, rose, and old blue.

The areas of even these grayed colors must balance before the rug shows a pleasing color scheme. The colors should not show any great contrast in light and dark, but should blend and seem to run into each other. The center of the rug should be of the lighter colors and the border the darker colors but even then they should overlap and appear to run together.

SIZE OF RUGS

The larger the rug, the more floor space it will cover and the heavier it will be. Such rugs keep their shape and place on the floor and combine well with groups of furniture. A living room should never have more than three throw rugs that are about 45 to 54 inches long. More than this number will give the room a spotty appearance.

Odd shaped rugs should never be used because they contradict and break the lines of the furniture group. Rectangular rugs repeat the shape of the room and the furniture outline

and are preferable to any other shape. Oval rugs also combine well in some rooms due to the fact that their shape differs from a rectangular one only in having the corners curved.

RUG DESIGNS

A poorly chosen rug design will often spoil an otherwise perfect rug. The design should conform in shape and size to that of the rug outline. Such designs strengthen the shape of the rug.

The designs should be arranged to give an all-over-the-surface pattern and not a spotty effect. All-over effects are achieved by connecting the larger forms and shapes with lines or smaller designs. Rug designs should never be confused with those suitable for pictures or wall hangings. Pictorial designs give one the sensation of crushing flowers, animals, and buildings when walking over them. A hospitable family does not need a hall mat with the word "Welcome" to make the guest feel at home; such designs should be omitted.

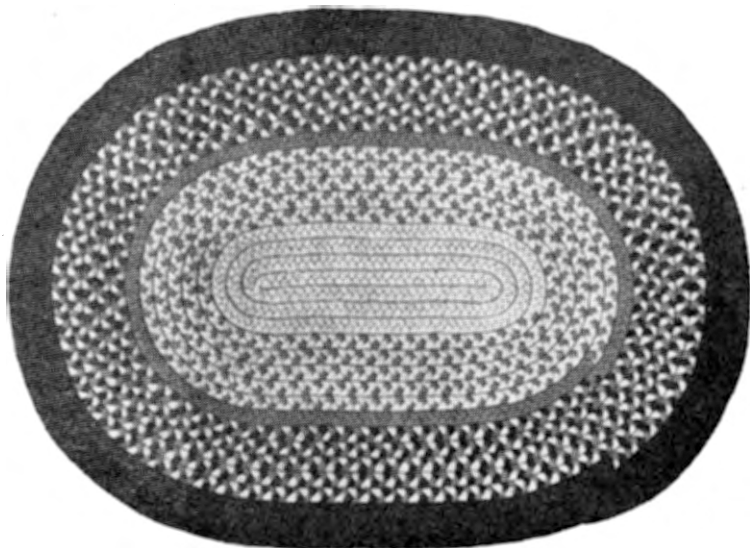

Fig. 2—Braided Rugs

BRAIDED RUGS

The most satisfactory homemade rug, both to the rug maker and for its use in the farm home, is the braided rug. Very little if any equipment is needed for making this rug that

is not already found in the home, and little expense is involved. Since the construction of this rug is less difficult than some of the other types, the rug maker has fewer problems to solve. Of course we have to admit that due to their poor construction many braided rugs are hardly worth the space they take up, yet it is easier for an inexperienced person to master the problems of constructing a braided rug that does not slide and that has weight enough to stay on the floor than it is to master the construction of other types.

Braided rugs are a favorite of the home decorator because they seem to be the finishing touch to an antique or cottage type of furnishing plan. They also give more service and keep their beauty over a longer period of time than other types of rugs even after their colors have faded.

MATERIALS—The most suitable material for a braided rug is wool, because it is heavy enough to give the rug enough weight to lie flat on the floor. It is also soft and pliable enough to work up smoothly and has the wearing qualities that justify the time spent in making the rug. Old woolen garments or wool blankets are usually of the deep colors preferred for rugs. Burlap sacks are of medium weight and can be dyed and used almost as successfully as wool, but they do not keep their colors or wear as long.

Cotton blankets, outing flannel, sheets and cotton garments are more suitable for bedroom rugs or bath mats.

Silk or knit materials are not suitable for braided rugs. Knit materials are difficult to braid firmly or smoothly because they are lighter weight than the other materials and they will stretch easily.

After the materials have been selected and dyed the desired colors, the next step is to cut or tear the garments *lengthwise* of the fabric into even strips which will braid into a strand a little less than an inch in width. The width of each strip will depend upon the thickness of the material used. Men's suitings and other woolens of medium weight should be cut about *one and three-fourths inches wide* as they can have the raw edges turned to the center and folded again to make four thicknesses of material. Heavier material that does not ravel can be cut narrower and possibly folded into only three thicknesses leaving one raw edge. It will be necessary to cut lighter weight materials about two and one-half inches wide as they will have to be folded to make six thicknesses of material in order that the strand will have the same weight as the heavier materials of four thicknesses. All the strands are folded to be

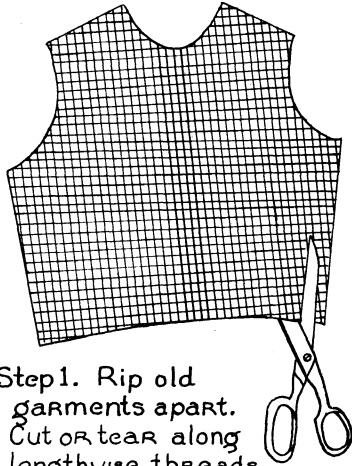

Step 1. Rip old garments apart. Cut or tear along lengthwise threads of old garment.

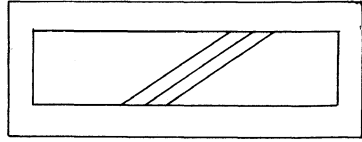

Step 2. Join strips on bias.

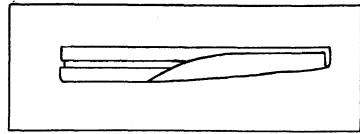

Step 3. Folding strips so raw edges do not show

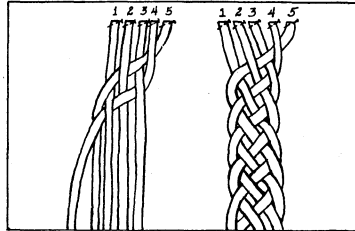
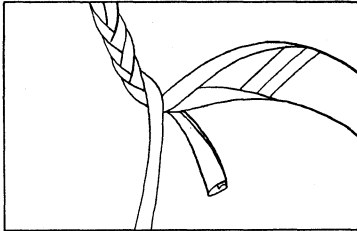

Step 4. Braiding with three strands. Braiding with five strands. Use uneven lengths.

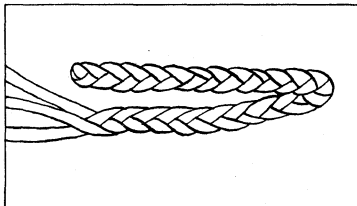

Step 5. First turn for oval rug

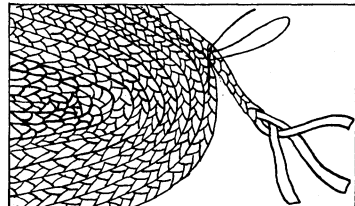

Step 6. Sewing

Fig. 3—Steps In Making A Braided Rug

the same width when braided together. Broad braids are less durable as their weight pulls the stitching apart. Tiny, narrow braids should be avoided because they are tedious to sew and their color effect is not pleasing.

Some material stays creased when pressed into a fold, but if the cloth is wiry it may need to be basted or blind stitched before it can be used for braiding. The prepared strips may be wrapped around pieces of pasteboard or piled loosely in a box or basket, keeping each color separate and in order.

BRAIDING AND SEWING—Three, four or five strand braids are most popular for rugs. Begin braiding with strips of different lengths, in order that only one joining will be made in the same place. Strips about one and a half yards in length do not tangle readily and are best for braiding.

Five strand braids make an artistic combination. This makes a braid about 1½ inches wide. Braiding with more than three strands is only a process of weaving the strands together. Starting with the right-hand strand or No. 1, put over No. 2, under No. 3, over No. 4 and under No. 5. Bring the strand back over the top of number 5 so it now becomes the second strand from the left. Start the next row of weaving by taking the right-hand strand and repeat the process of going under and over. Care should always be taken to keep the braid as even as possible and this is done by folding the outside strand back and over to start a new weave instead of pulling it around.

Sew the strips together and fasten firmly, hold the open end down, then braid with a straight, folding motion, turning the strips at about the same angle each time in order that the edge will be even and easy to sew. Be sure that the braid is tight, firm and smooth. When the end of the strand is reached, open the fold, cut on the true bias where it will be crossed by another strand, and make a smooth, flat seam, lapping the edges about ½ inch, being careful that the braid does not bulge. Never have two joinings in the same place.

When several yards have been braided, begin sewing the braids together. A good rule to follow in starting to sew the braid for the center, is to estimate the size of the finished rug, and have the first braid one-third as long as the rug will be when completed. For instance if the rug is to be 24"x36", the center braid should be 12" long.

A short darning needle and heavy cotton thread about No. 8, or linen carpet thread are the best for sewing the rug. Do not whip the braids together. Use a blind or slip stitch, catch-

ing the strips first on one side then on the other. The stitching should be invisible, which makes the rug reversible and also increases the wearing qualities, as there will be no stitches in contact with the floor.

By working on a table, the rug may be held flat, and its weight will not pull it out of shape. Allow enough fullness for smooth curving at the turn of the coil in a round rug or at the end turn in an oval rug. In turning the row at the end of an oval rug, the inner strand of the braid may be pulled a little tighter to avoid cupping.

When another strip is to be joined to the section already sewed, unbraid the ends of both the new and the old strips for a distance of an inch and a half and weave the ends together sewing them securely on the wrong side. If each section is to be finished completely and the new braid sewed on, it is best to finish off the last round by tapering the braid into the rest of the braids, thus making a smooth inconspicuous joining. If seams are to show, care should be taken to distribute them around the rug to leave no rough places.

In order that no open places will be left, it is very important to sew a rug carefully and firmly. Braid and sew alternately; this method enables one to work out the desired pattern. When the rug is finished, it should be covered with a damp cloth and pressed into shape. Press from the center out, and allow it to dry thoroughly on a flat surface before being placed on the floor for use.

The appearance of the rug is the final test. A good braided rug should have the following qualities: Simplicity, beauty, and utility. It should lie flat on the floor, be well constructed, and neatly finished.

HOOKED RUGS

Hooked rugs are a test of the artistic ability of the rug maker. No other type offers the opportunity for expressing the individuality of the rug maker's sense of beauty, love of color and design, and careful workmanship.

There are three types of hooked rugs in the home—the looped, the clipped, and the tufted. The looped rug is the one most commonly made. In it the material is pulled through the foundation to make a loop in the hole of the burlap, the loops following the first loop are made of the same height and as close together in the row as the needle will allow. In a clipped rug, the loops are made longer and can be clipped with

the scissors. The tufted rug has longer loops than the other two. The loops can then be cut at an angle, to gradually taper into the background. Tufting is effective for some patterns as leaves, some flowers and some geometric designs.

CHOICE OF MATERIALS: Wool is preferred but silk and ravelings of burlap may also be used successfully. The width of the strips used depends upon the weight of the material. Heavy, firm material is cut about $\frac{1}{4}$ inch in width while light weight materials should be cut wider to give the same weight to the rug. Silk hose and knit underwear should be cut from $\frac{1}{2}$ to 1 inch in width. They may be cut lengthwise as for braided and crocheted rugs or cut spirally.

The foundation for hooked rugs should be heavy, closely woven burlap about 12 to 14 threads to the inch each way. Gunny sacks or tow sacks or round bale cotton bagging may be used just as well as burlap bought by the yard. The sacks should be ripped, washed, and dipped in starch to which one-half teaspoon of powdered gum Arabic has been dissolved. This restores the dressing lost in the wash water and gives the firm foundation necessary for hooking the rug. Iron while damp on only one side. The reason for this is that under the heat of the iron the starch will give a glossy surface on which to draw designs. The starch and gum Arabic also give a stiffness to the foundation that makes it easier to push the hook into the surface. A loose or limp fabric slows down this process.

DRAWING THE DESIGN.—It is well to make a small design on paper and work out the color scheme with crayolas. As the colors are filled in, changes may be needed in the design. It is easier to do this on paper than on the rug foundation or after part of the rug is hooked. After deciding on the colors, the design may be stamped on the burlap base.

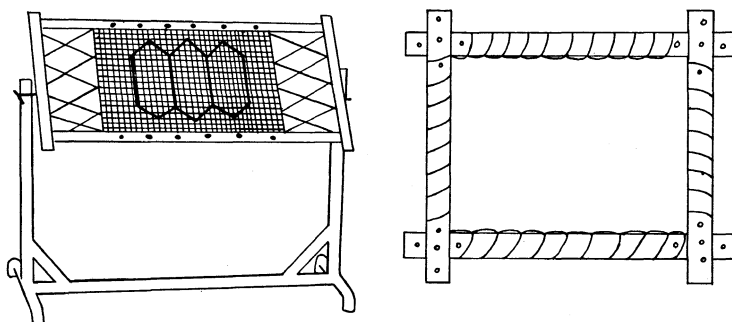

Fig. 4—Types of Frames

Allow about 4 to 6 inches on the burlap around the outside of the design. This width is used to fasten the burlap into the frame. Transfer the design by tracing from the center of the design out.

Fasten the burlap pattern into the frame by using heavy, long thumb tacks or by sewing it tightly.

HOOKING THE RUG.—Few rug makers agree on which type of needle is best. Each has her favorite and finds it the easiest to use. After all, it is the quality of work that makes the rug; the rug maker should try various types of needles and select the one that she can handle best.

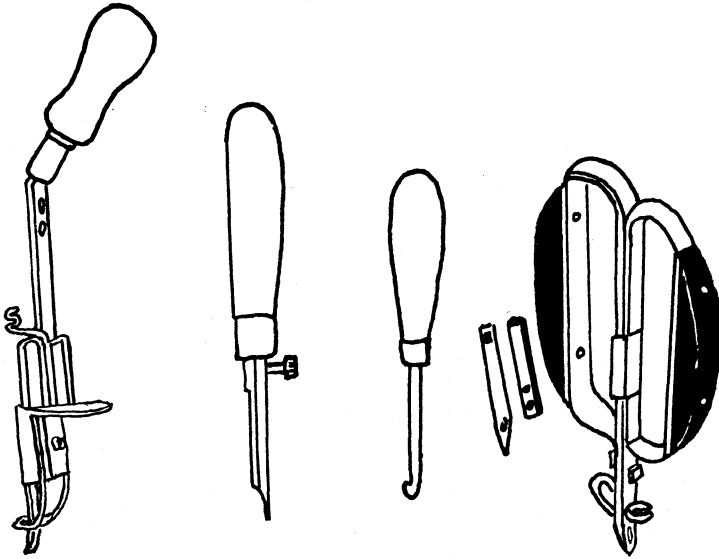

Fig. 5—Types of Needles Used for Hooking Rugs

There are three types of needles—the hook, the punch needle, and the automatic needle.

The method for hooking depends upon the type of needle used. Directions for hooking are usually printed and illustrated on the box that holds the commercial needle. If the needle is bought in the art department of a department store the sales girl will demonstrate the method necessary for using that type of needle.

Enlarged Drawing of Process of Hooking Rugs

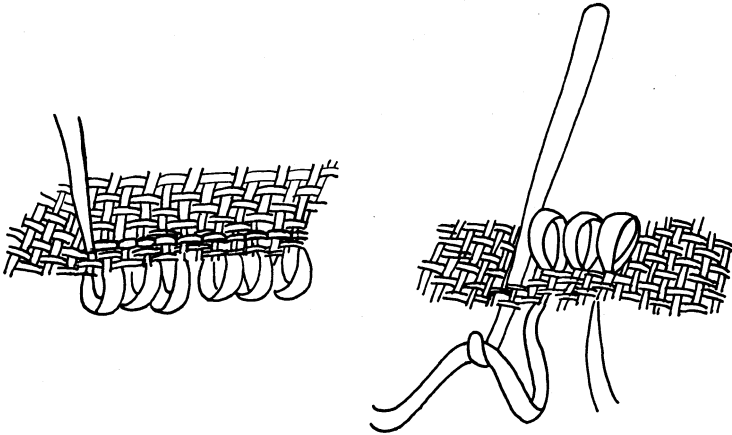

Fig. 6—The Punch Needle or Automatic Needle

The Hook

The outline of the design should be hooked first and then the colors filled in. This prevents cupping and insures a smoother surface. When one design is finished the background around it can be filled in. This keeps the work from becoming monotonous. Whenever it is possible, go from right to left with one long row of loops. Stop at the end by bringing the end of the strip to the right side so it will be inconspicuous. Begin next row at extreme right and continue as before to left. This helps to keep the finished rug straight and in shape when lying on the floor.

Hook the row of loops as closely together as possible and be sure they are the same length and size. If the pile seems heavy or a design cupped, it may be necessary to skip a row of the burlap. *Never skip* more than one row in any one spot as these skips do not have the thickness of the loops and have no resistance to wear. The border should be hooked more closely than any other part, in order to give the weight needed to keep the rug in place on the floor and hold it in shape. Each row of loops may be clipped with sharp scissors as the work progresses, or the clipping may be done after the rug is completed. The latter is sometimes preferred because one may wish to make the decision of clipping or not clipping after studying the finished effect.

The durability of an unclipped rug is not a great deal more than that of a clipped one, so if clipping the surface adds to its beauty, do not hesitate to do so.

Go over the finished rug and check the following:

1. Look on the wrong side to see that there are not more than two rows of burlap exposed in any one spot.
2. See that all ends are pulled through to the right side leaving no loose ends of the material on the wrong side.
3. If the loops are to be clipped, there should be none left unclipped.

After removing the rug from the frame, turn back a one-and-one-half- to two-inch hem on the burlap back and shape it to the border of the rug. Miter the corners of a rectangular rug and ease in the fullness of an oval one as you do the hem on a circular dress skirt. Baste the hem and finish it with the hemming stitch or catch stitch.

The back of the rug should then be dampened and pressed before being placed down on clean papers to dry on the floor. It should first be walked on in this position until the rug is well shaped and the stitches are flattened. Then turn the rug to the right side and use in the usual way.

A carefully constructed hooked rug will not need a lining to give it added weight nor the back sized to hold it in shape as the closeness of the looped design gives it the necessary weight and holds it in shape.

CROCHETED RUGS

The crocheted rug is one of the most simple for the amateur to make and is favored by the majority of rug makers. Yet there are more mistakes found in its construction than in any other type.

It is possible to crochet a rug that has beautiful colors, one of artistic design and of sufficient size and weight to keep its shape when in use on the floor, yet few crocheted rugs have these merits.

MATERIALS—cotton, silk, rayon, or lisle.

EQUIPMENT—bone, wooden, or steel crochet hook. The size and kind of hook will depend upon the kind of material used for the rug.

PREPARATION OF MATERIAL—Cut or tear strips in uniform widths. The width will vary from one-half to one inch depending upon the kind of material and its weight. Join the strips by lapping the end of one over the end of the other and

sewing securely. Fold or press so the raw edges will not show. Wind the strips on cardboard or into balls keeping the various colors separate.

If lisle hose are used, cut across as in Figure 7, step 1. Again the width of the strips will depend upon the weight of the hose. These rings of the hose form links that can be joined without sewing. See steps 3, 4, 5, and 6 in Figure 7.

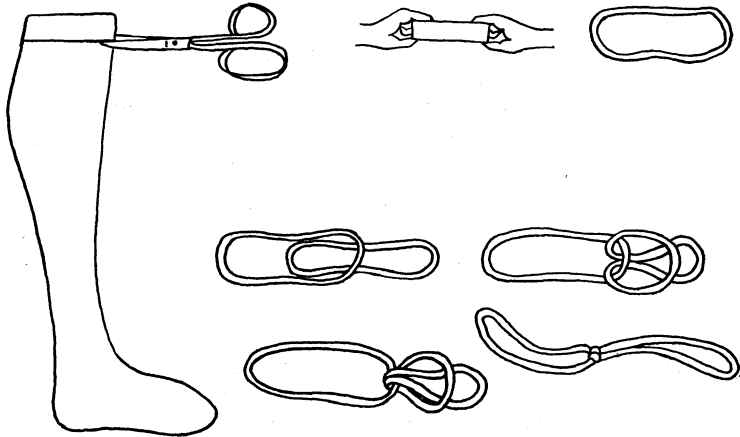

Fig. 7—Steps in Joining Links of Hose for Chain.

CONSTRUCTION—Oval Rug—Make a chain one-third the length desired for the finished rug. Use the single crochet stitch, being sure to use close firm stitches around this chain, widening at the curved ends in order that the rug will lie flat and be perfectly oval in shape.

Caution—It is wise to measure the length of the center chain after you have gone around it with the first row of the single crochet stitch because few people crochet with the same firmness of stitches and at this point some find the chain is far less than one-third the length desired for the finished rug.

The surface of the rug will be smooth if the hook is put through both loops of the previous row of single crochet. Rugs made by this method are firmer and hold their shape longer.

The surface is more interesting in design if the hook is put through only one loop of the previous row of crocheting, being careful to pick up the loop farthest away from you. Of course the stitch is not as firm as when both loops are picked up so the rug is lighter weight.

Continue crocheting by one of these methods changing colors according to the color plan chosen. Refer to General Factors for Rug Making in introduction for rules regarding rug color schemes. As the rug grows larger, add extra stitches only at the curved ends. It may be necessary to skip a stitch occasionally along the side as too much fullness will keep the rug from lying flat.

ROUND RUGS—Although oval and rectangular rugs are preferred for throw rugs, round rugs may be used successfully when they are of sufficient size to cover the central floor space.

Chain three or five stitches depending upon the weight and kind of material. Join the last stitch to the first one to make a tiny coil. Single crochet with a firm close stitch around this coil, widening by taking as many extra stitches as needed to keep the rug flat.

PRESSING—Cover the finished rug with a damp cloth and press into shape from the center out.

WOVEN RUGS

A loom or frame of some type is required for weaving rugs. A two- or four-harness loom is a complicated piece of equipment and can not readily be improvised at home. Commercial ones of this type are on the market. Their size limits the width of the rug and their type limits the process of being operated by hand, lever or foot treadle. Directions cannot be given here for threading commercial looms as each type is different. The rug maker can learn the process when she buys the loom.

It is possible to make woven rugs on a homemade frame made from broom handles or strong pieces of board from one- to two-inches in diameter. An oblong frame is usually preferred as the four boards hold both the warp and woof in perfect shape while weaving.

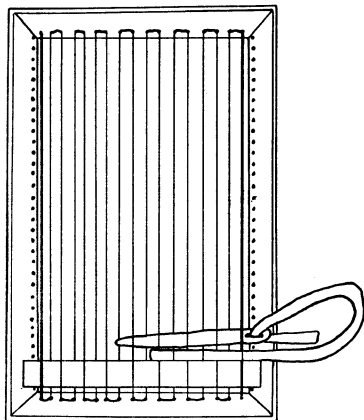

Fig. 8—Homemade Loom.

To thread homemade looms.
Drive shingle nails one-half inch apart at each end of the frame and one-half inch apart at the sides.

Thread loom by tying the warp (strong cord, carpet warp, or strips of material) around the first nail on one end of the frame, carry it down the length and around the opposite nail at the other end, bring the strip back to the opposite end around the next nail, then to opposite nail on the other end and continue until all nails on each end have been covered, fastening the end of the strip

to the last nail on the same end that you began threading the frame.

The woof is the crosswise stitch woven with strips of muslin, print, burlap, overalls, shirts, or silk. The width of the strips is determined by first cutting a sample and testing it by putting in a couple of rows. Usually strips $\frac{3}{4}$ to 1 inch wide can be used. The lighter weight the material, the wider it should be cut as the stitches must pack in tightly and closely to give a firm even weave.

After the material has been cut the desired width, it should be folded and pressed so that no raw edges will be seen on either side of the surface. All joinings should be sewed on the bias and folded to insure a good appearance.

Thread a strip of material through the needle. Leave four or five inches of the strip sticking out at the right side of the first warp strand and put the needle over two and under two warp threads from right to left. When the needle has reached the left side, stop and weave the four- or five-inch end in and out lapping around the warp at the right selvedge for fastening. In reversing the needle for weaving from left to right, first wrap strand around nail to keep the margin straight and keep the rug in shape. Pass needle back by dividing first two weavers and go under the first one above and then continue under two and over two. This of course divides all of the weavers of the first row across the rug and makes a firmer weave and a more interesting design. This process is repeated

from side to side until the needle is empty or until a different color is added. As usual, make joinings on the bias and fold in the raw edges.

As each row of weaving is put in, it should be beaten down tightly. This may be done with a homemade toothed instrument or a coarse toothed comb.

The design of course is developed by changing the color of material or changing from printed in one section to plain material in another. Lengthwise stripes may also be produced by using different colors of warp. Odd numbers and different widths of stripes are more interesting than even numbers and uniform spacings.

The design and colors will have harmony if the colors at the ends are similar or closely related to the colors in the center of the rug. Finish the selvedge with the end of the strip just as the rug was started. Remove the rug from the frame. The ends may be left plain or finished with fringe made of the material or warp threads.

TOOTHBRUSH HANDLE RUG

This type of rug is superior to a crocheted rug as it is possible to make a firmer stitch and a heavier rug with the stitch made by a needle from a discarded toothbrush.

Cut the handle off just below the brush. Most people find that it is best to make the needle as long as possible as it is easier to use. Finish the end with a file or a piece of glass until it is a smooth, blunt point. Enlarge the hole if it is too small to carry the material.

Use the same colors, design, and material as were suggested for a crocheted rug. It is possible to use badly worn or thin cottons for this type of rug as the firm stitch gives the rug the body it requires. The width of the strips will depend upon the weight of the material. A $\frac{3}{4}$ -inch strip is usually satisfactory. Cut strips lengthwise of the material so the edges will roll in as the stitches are made.

To BEGIN RUG

There are two methods that may be used. Both have been successful.

1. Crochet a chain as long as needed. The usual allowance is one-third the length of the finished rug, but some of the length may be taken up in making the first row around this, so it may be necessary to make the chain longer.

2. Braid three strands of the material loosely, making it one-third the length of the finished rug. Clip two strands and fasten the ends in order that the raw edges do not show and leave one strand to thread the needle.

Turn the strip to bring the loose strand at the left end. Thread end into the bone needle made from the toothbrush handle. Insert needle into the first loop to the right of the strand and cast on two stitches as in knitting. There will now be three stitches on the needle.

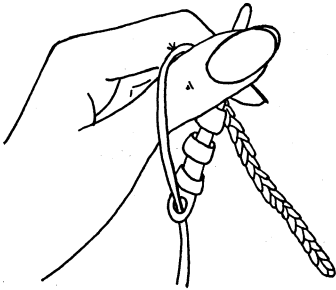

Fig. 9—Position of Left Hand.

Hold the needle with the 3 stitches between the thumb and the forefinger of the right hand with the braid extending to the right and the strip thrown over the thumb. The strand left should not be more than 18 inches in length as only short lengths can be used for this stitch.

Pull the needle up through the loops. This forms a loop on the thumb. Now insert the needle in next fold of braid, then through *last* of the stitches previously taken off the needle and cast loop off thumb on to needle, making 3 stitches on the needle. Pull needle through as before, throw strip around thumb and continue working from left to right, changing colors and designs of strips as needed. Sew strips together by lapping or on bias as for braided rugs. It will be necessary to go in some stitches twice in order to give the fullness needed for the rug to have a perfectly flat surface.

KNITTED RUGS

These are very attractive but seldom as usable as other types because it is almost impossible to knit tightly enough so the rug keeps its shape when in use.

ADDITIONAL TYPES

There is always a new type of rug being demonstrated at fairs and in shops. Some are practical and usable but they are usually invented to sell a sewing machine attachment or a piece of equipment. It is well to check the factors mentioned in the introduction and see if the new type of rug will pass

these tests before buying new equipment and changing from the old methods of braiding, hooking, or crocheting rags into rugs.

MINIATURE RUGS OR MATS

Small braided, hooked, crocheted, or woven mats are often more useful than doilies or scarfs. Home decorators of today prefer to have all of the polished table top exposed and not covered, yet a tiny mat or doily under a bowl of flowers or a piece of pottery will protect the surface from rough spots or moisture. Homemade mats also add a decorative touch and a spot of color.

CHAIR SEATS AND PADS

The small rug may be made the same shape and size as the chair seat or the chair back. These make an excellent, durable pad and possess the quaint charm and individuality that an old-fashioned chair may need for its finishing touch.

ARRANGING HOMEMADE RUGS

The rug should have been planned and made for a certain floor space with a group of furniture. Then its shape, size, and color is in harmony with the group. It is best never to use more than two or three throw rugs in a bedroom or three on the wood floor or plain carpet of a living room.

Small or throw size rugs should never be placed in the center of the room. If so used, they will seldom be in place because they will slide or be kicked up as the family walks through this middle passageway.

The rug should never be placed diagonally because that interferes with the structural unity of the massive pieces of furniture and with that of the room. It should be arranged in line with the important piece of furniture in that particular unit or group with which it is used. We know that such pieces as a bed or a dresser in the bedroom or a divan, piano, chest, large tables, etc. in the living room will be arranged parallel with the wall.

CLEANING HOMEMADE RUGS

Hand-made rugs must *never be shaken* or hung over a line and *beaten* to remove the dust. The weight of the rug will strain and break the threads if either of these methods is used. Rugs should be placed on a smooth surface and carefully swept

on both sides with a brush or broom. Well-made rugs may be cleaned occasionally with a vacuum cleaner. This method cannot always be used on hooked rugs because a vacuum sucks up the fine particles of dirt from the depth of the pile and in time may suck up loose threads and spoil the loops of the rug.

It is well to have all rugs thoroughly cleaned once or twice a year to remove the dirt that cannot be reached by sweeping. Of course all rugs keep their color and beauty longer if they are dry cleaned but most braided, woven, and crocheted rugs can be washed satisfactorily if given the same care that would be given garments made of these materials.

It is very important that the rugs be rinsed thoroughly. The best method is flushing with a hose or with pails of water until the water that runs off the rug is clear, showing that no suds remains.

Although it is always safer to have hooked rugs dry cleaned, they may be washed *if they are not put into the water*.

The following method is usually successful when washing hooked rugs or any rug with a pile weave.

Make a good lather of a pure mild soap. Apply with a soft brush or cloth to only a small section at a time, because the suds should not remain on the rug any longer than is necessary. Be careful to rub the suds only until the surface is clean in that one section. Rinse at once by dipping a clean cloth in clean lukewarm water and rub gently. Change the water as it becomes discolored and continue rinsing until no suds remains on the surface. When the entire rug has been covered by this method, place the rug where there is adequate circulation of warm air and allow it to remain until thoroughly dry before using.

SPOTS OR STAINS.—Stains and spots should be removed while fresh. Use the method necessary for that particular stain and then sponge and rinse according to the suggestions given for washing hooked rugs. Most spilled liquids can be lifted with an absorbent cloth. Cover the spot with talcum powder, corn starch, or corn meal to absorb the remaining liquid. Then apply suds and rinse. Spilled ink can be lifted by the above method, then sponged with sweet milk until the spot has disappeared. Sponge area with a mild suds and rinse. Gum or wax can be lifted from the surface and the stain that remains removed with cleaner's solvent or carbon tetrachloride. Wash spot with suds and rinse.

