

OSU

Collection

OKLAHOMA AGRICULTURAL EXPERIMENT STATION

Oklahoma A. and M. College, Stillwater

W. L. BLIZZARD, Director

LOUIS E. HAWKINS, Vice Director

In Cooperation With  
SOIL CONSERVATION SERVICE  
U. S. Department of Agriculture

Experiment Station Bulletin No. B-280

March, 1944

# HIGH-LIFT POWER BUCK RAKE

By

MAURICE B. COX

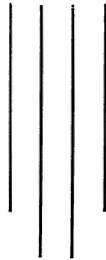

A High-lift Rake Developed for Land Clearing Operations

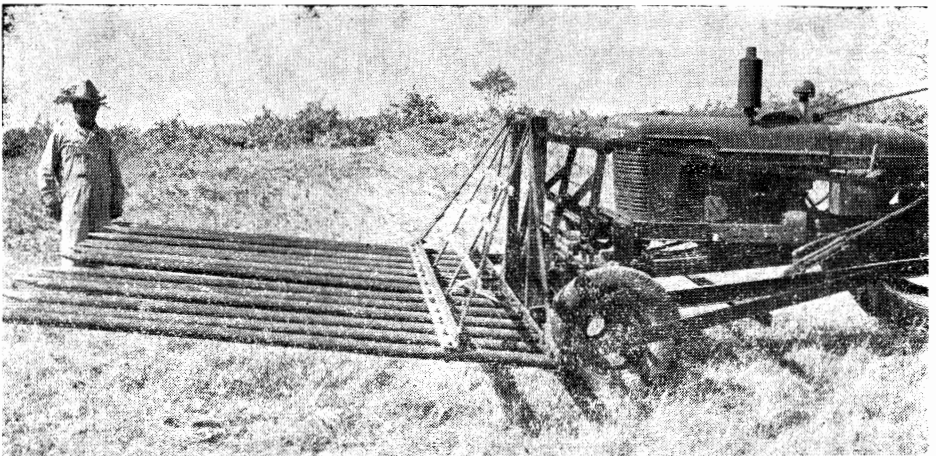



# HIGH-LIFT POWER BUCK RAKE

By MAURICE B. COX\*

As new land use practices develop (1), new machinery is needed for the better methods of farming. Due to the demand for greater food production and more efficient use of all land (3), much of the rough and formerly unused soils are being converted to pasture and hay crops. Investigations (2) have also shown that grass and beef production on scrubby black-jack land was greatly increased by removing the small trees and brush. Through these intensive land use practices, there is a special need for a high-lift power buck rake that will operate over rough ground, depressions and terraces.

After the trees and shrubs have been cut, the brush must usually be removed for grassland improvement. Burning brush where it falls is often difficult. It is also undesirable, first, because the intense heat generated is detrimental to the grass, and second, because the bushy material is valuable for land reclamation and gully control. Hand methods of moving brush are expensive, particularly if it is loaded on trucks or wagons for hauling to gullies or a central stack.

To reduce this cost, a hydraulic high-lift buck rake, which operates on a tractor, was constructed. The high-lift (Figure 1) raises the load sufficiently to permit operation over rough ground. It also eliminates dragging of branches that might hang below or over the sides of the rake while the load is being transported or during turns.

The high-lift rake was also found useful for handling hay on rolling or terraced land where the ordinary low-riding buck rake often does not operate satisfactorily. Loading will require the same conditions as any other buck rake, but the loads may be transported across terraces or depressions. After the load is free of the ground, it is carried well above normal stubble, and the distance traveled before unloading is no longer a major problem.

The cost of material used in the rake, based on pre-war values of new material, is \$44.57. The estimated time required for construction, including time lost in adjusting original de-

---

\* Assistant agricultural engineer and cooperative agent, Soil Conservation Service and the Oklahoma Agricultural Experiment Station, with headquarters at the Red Plains Conservation Experiment Station, Guthrie, Oklahoma. The author wishes to express his appreciation to various members of the station staff, Guthrie, and Cherokee, Oklahoma, for helpful suggestions in constructing the rake and preparing the manuscript. Approved for publication by Dr. M. L. Nichols, chief of research, Soil Conservation Service, February 16, 1944.

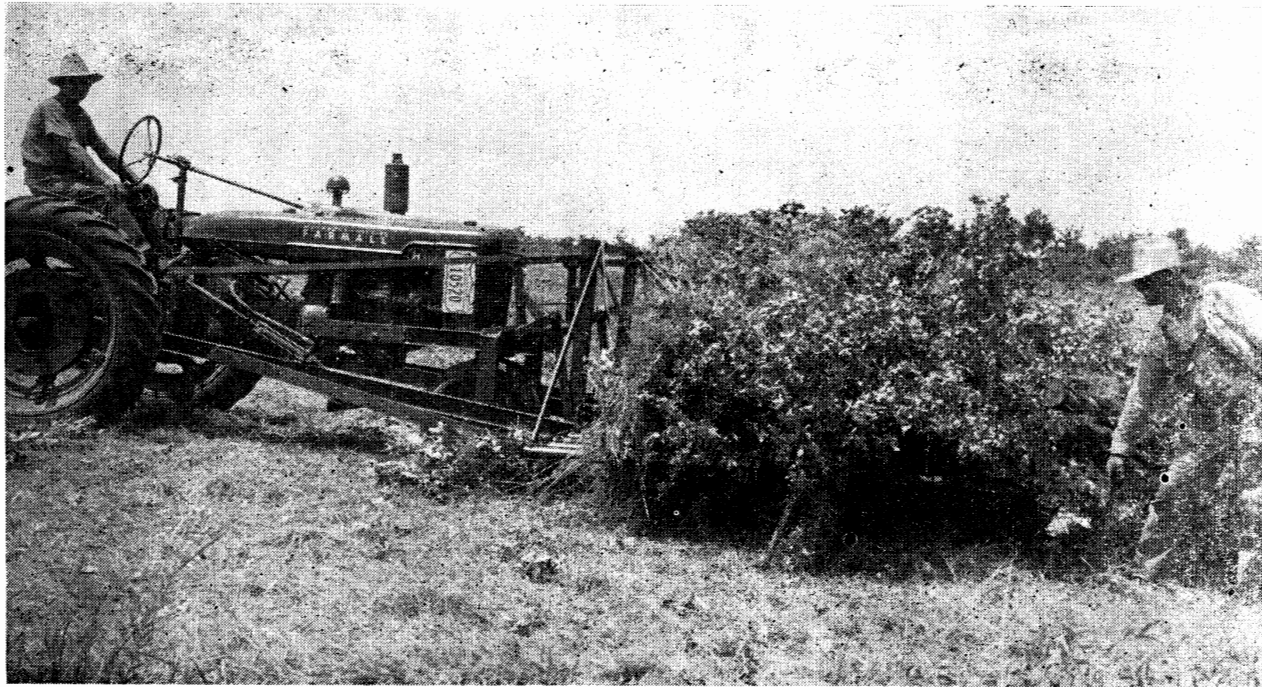

**Figure 1. Power lift buck rake makes an easy job of removing small trees and brush from land by mower, power equipment or hand. Although the rake is in the raised position in this picture, the ground clearance is less than described in the text, due to the small tires on soft ground.**

sign detail and adaptation of available material, was 15 man days. The time needed to build a duplicate should be considerably less.

### DESCRIPTION OF RAKE

The rake was designed to operate on either a tricycle or four-wheel tractor (Figures 1 and 2, respectively). It worked equally well on either tractor when the ground was dry, but the four-wheel tractor showed an advantage when soft or wet spots were encountered. This advantage was increased by the use of standard tires that did not have the steering rim treads as shown on the tricycle tractor in Figure 1.

The rake was made for a type "H" McCormick-Deering tractor but it can be adapted for use on any tractor with similar hydraulic lift attachment. With slight modifications, this type rake may be fitted for use on most other modern farm tractors.

The rake shown is twelve feet wide, with teeth  $8\frac{1}{2}$  feet long, spaced 12 inches from center to center. The rear ends of the teeth, in operating position, clear the ground by 10 inches. The cross-members to which the teeth are bolted are spaced so that the holes in the teeth are 18 inches, center to center. This distance is 12 to 16 inches on most commercial buck rakes.

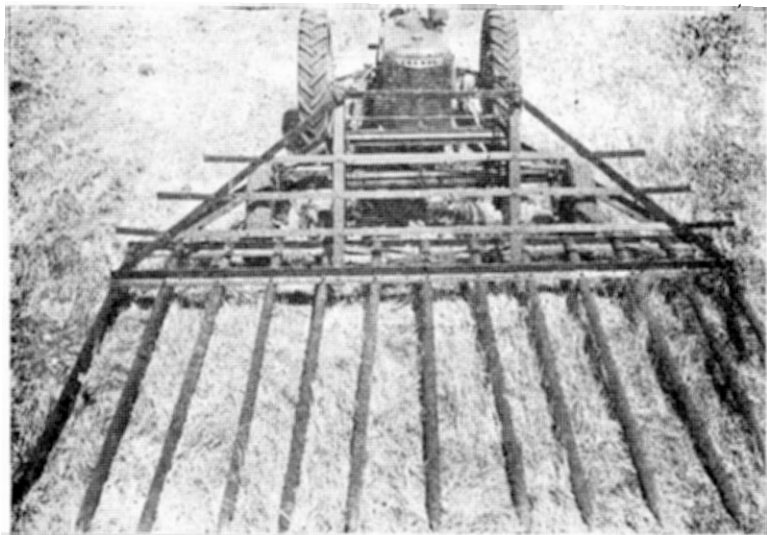

**Figure 2. Front view of 12-foot high-lift buck rake with metal teeth. Wooden teeth may be used for handling hay.**

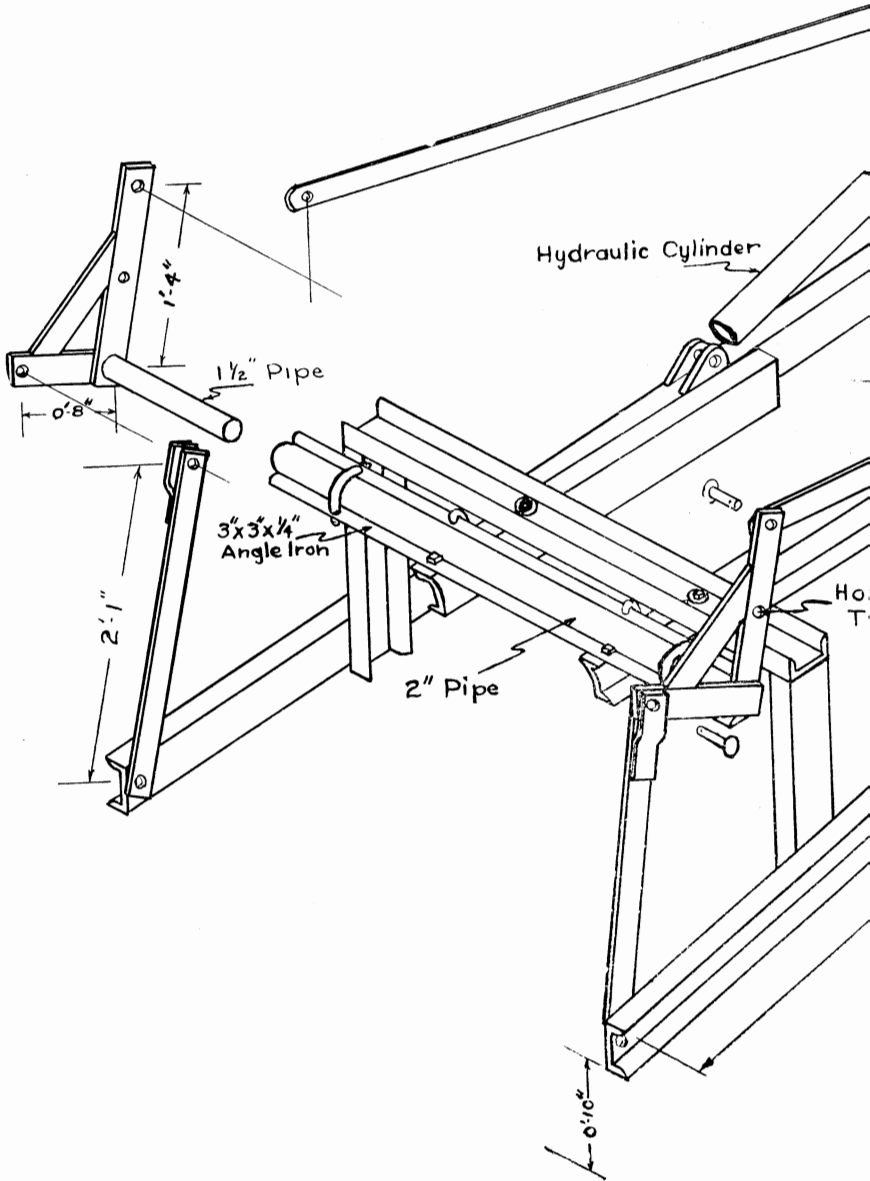
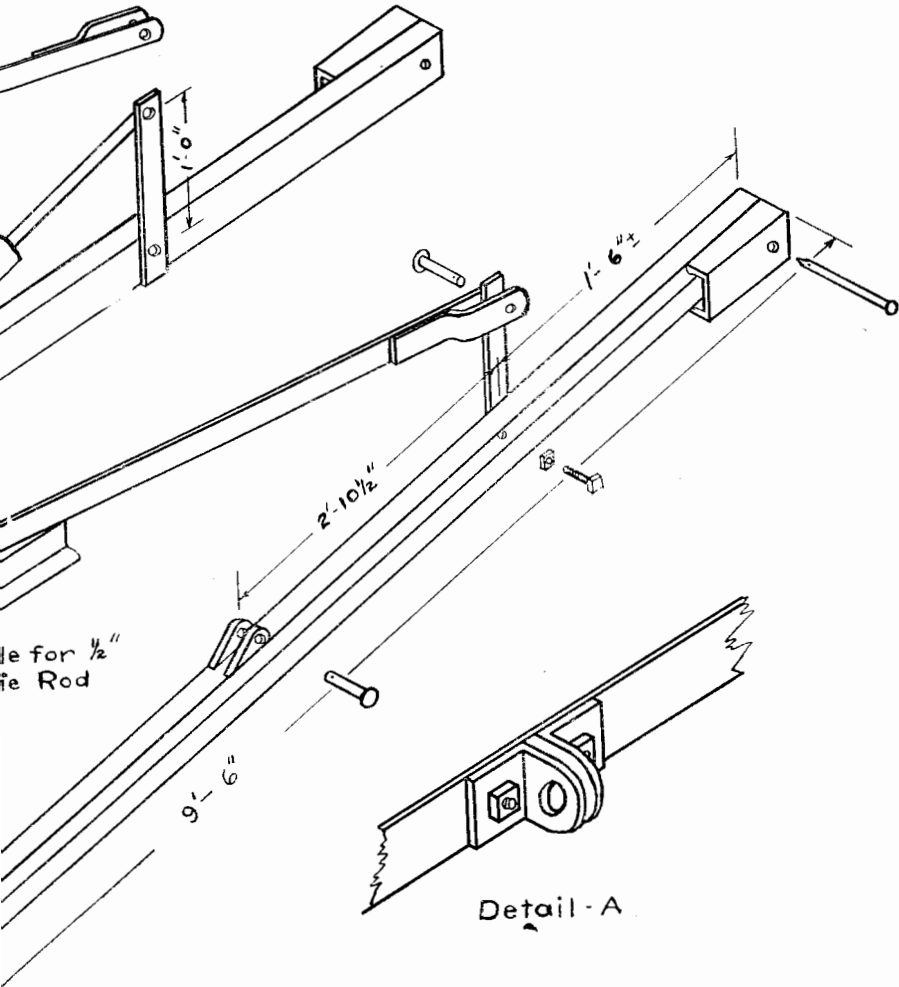

Figure 3. A detailed drawing of the push beam and lifting linkages of the lifting linkage

*High-Lift Power Buck Rake*



buck rake as designed for the Type H, McCormick-Deering tractor. Details are shown in Figure 4.

The rake teeth were made of used two-inch pipe. Use of pipe to replace the usual wood teeth was to allow them to bend or give without breaking if they struck a stump or stone. The metal teeth also give more flexibility in picking up larger trees. An over-loaded tooth will give down without breaking, and allow additional teeth to take part of the load.

For handling hay, it may be desirable to equip the rake with standard wood teeth, which can be done by removing the two bolts that hold the teeth and making the exchange. Wood teeth would reduce the weight of the rake about three hundred pounds.

When the rake is in the raised position for transport or for carrying a load (see cover picture), the points of the teeth are 24 inches above the ground and the rear end is raised to 14 inches. The raising of the entire rake is advantageous in moving the machine into or out of the field as well as giving more clearance for moving the load. If desired, the rear lift can be disconnected and the frame made rigid by bolting the channel beams to the guides at the front of the tractor. When this is done, the action of the cylinders will be utilized only for tilting the rake, thus raising the points of the teeth about 18 inches.

## CONSTRUCTION DETAILS

### The Frame

The force required for loading is transmitted to the rake by two channel irons extending back to the rear axle of the tractor (Figure 3). These beams are secured to the tractor by clamps placed around the axle housing in such a manner that pins through the ends of the beams allow a hinged joint for movement in lifting and for ease of assembly. The clamps used are parts of another attachment furnished with the tractor. The rake is lifted by two hydraulic cylinders (Figure 4) that are supplied with the tractor for other attachments.

### The Lift Coupling

The bell-crank mounted at the front of the tractor (Figure 3) for lifting the rear of the rake is made with the vertical arm 16 inches, and the horizontal or lifting arm 8 inches. The links between the upper end of the bell-crank arm and the back frame of the rake consist of two pieces of strap iron each, which eliminates the construction of yoke ends. The length of the tilting lever, or the vertical member of the back frame, is 36 inches. These lengths of levers utilize a travel of 8 inches



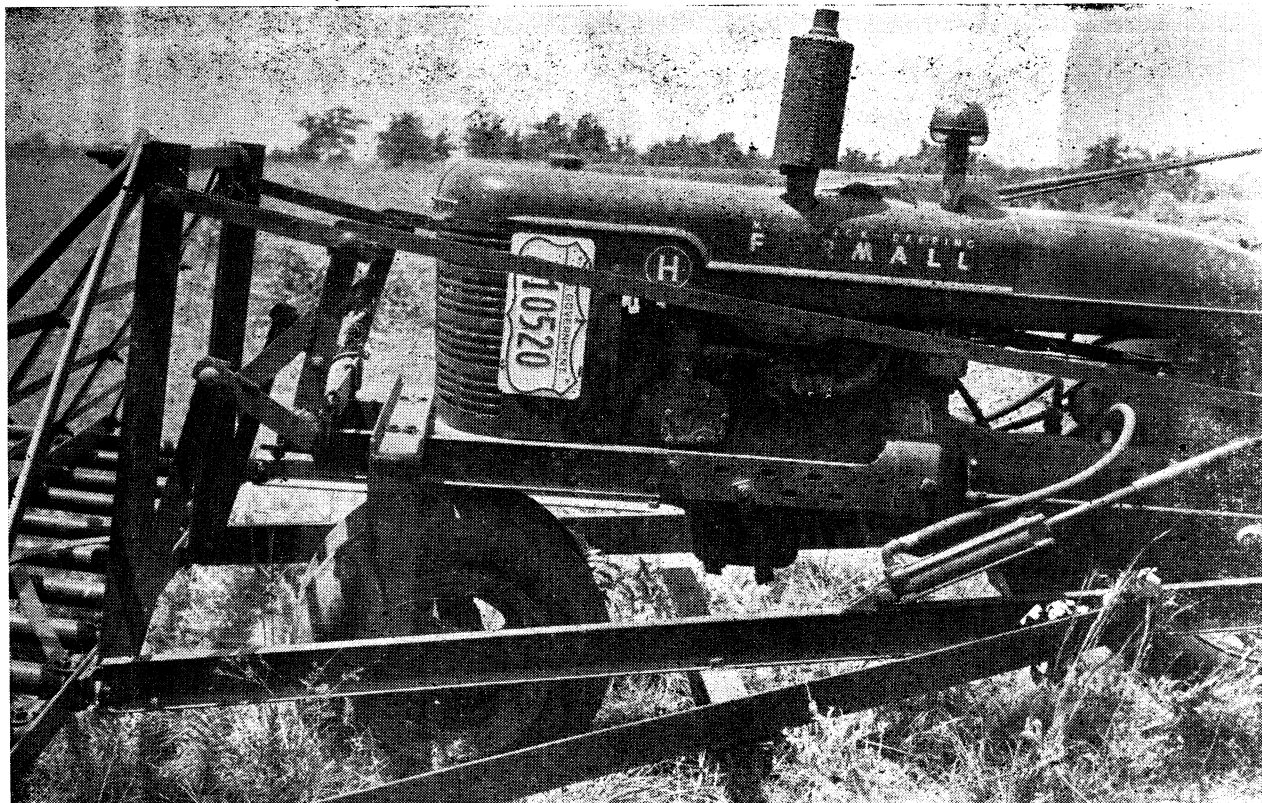

**Figure 4. Arrangement of the hydraulic cylinders and levers that raise the back of the rake four inches, and the points of the teeth 24 inches.**

on the hydraulic cylinders and will lift a 1,000-pound load centered on the rake teeth with a 1,000-pound thrust from each of two cylinders.

#### Frame Connection

The pivots at the back of the rake, that attach it to the push frame and allow the teeth to be raised, are made of section of angle iron (Detail A, Figure 3). These sections are bolted to the rear cross-member with movable pins passing through the ends of the pushing frame. Two angles are needed for each connection, except that the vertical members of the back frame are located so that the lower ends are utilized for one side of the pivot. Pins equipped with cotter keys make the job of mounting or dismantling much easier.

#### SUMMARY

The description, operation and method of construction is given for a high-lift power buck rake which operates on a farm tractor. Due to its ease of operation and high-lift, it is especially designed for land clearing operations. The high-lift permits the transporting of rather heavy loads of hay, brush or small trees over rough ground, depressions and terraces.

LITERATURE CITED

1. Daniel, Harley A., Elwell, Harry M., Cox, Maurice B.  
Investigations in Erosion Control and Reclamation of Eroded Land at the Red Plains Conservation Experiment Station, Guthrie, Oklahoma 1930-40.  
U. S. D. A. Tech Bul. 837, 1943.
2. Elwell, Harry M.  
Progress Report of Land Reclamation and Pasture Investigations on Abandoned and Scrubby Oak Areas in Central Oklahoma.  
Okla. Agri. Exp. Sta. Mimeographed Cir. M-86, 1942.
3. Markensmith, R. D., and Steele, J. C.  
Classifying Land for Conservation Farming.  
U. S. D. A. Farmers' Bul. 1853, 1943.

