

# Patent Law:

## An Open-Access Casebook



# Patent Law:

## An Open-Access Casebook

Version 1

Sarah Burstein  
Sarah R. Wasserman Rajec  
Andres Sawicki

Copyright © 2021 Sarah Burstein, Sarah R. Wasserman Rajec & Andres Sawicki

ISBN-13: \_\_\_\_\_

This work is licensed under a Creative Commons Attribution-NonCommercial-NoDerivatives 4.0 International License. For a summary of that license, and a link to the license's legal terms, please see <https://creativecommons.org/licenses/by-nc-nd/4.0/>. Please note that although we have restricted the creation of derivative works, we may be willing to approve particular derivatives that you may wish to create. If you wish to create a derivative, please contact us. Thank you.

# Acknowledgements

The authors thank Jeremy Sheff, for his early enthusiasm, guidance, feedback, and contribution of his own materials, and other support; Jeanne Fromer and Christopher Sprigman, for excellent advice on writing an open-access casebook; Joe Miller, for sharing his materials so generously; Jocelyn Bosse, for very helpful comments on the Plants chapter; Taylor Lain and Kayla Molina, for excellent research assistance; Leslee Roybal and Ashley Shaw, for proofreading and editing assistance. We also thank all of the students and professors who used and read the alpha and beta versions of this book for helpful feedback.



## About the Authors

Sarah Burstein is a Professor of Law at the University of Oklahoma College of Law. Prior to becoming a law professor, Professor Burstein worked as an intellectual property litigation associate in the Chicago office of Kirkland & Ellis LLP and served as a law clerk to the Honorable Robert W. Pratt in the United States District Court for the Southern District of Iowa. Professor Burstein has a law degree from the University of Chicago and B.A. in Art & Design from Iowa State University.

Sarah R. Wasserman Rajec is a Professor of Law at William & Mary Law School. She has a law degree from the University of Michigan and an Sc.B. in physics from Brown University. Following law school, Professor Rajec practiced patent litigation in the Boston office of Fish & Richardson, P.C. She subsequently served as a law clerk to Judge Donald C. Pogue of the U.S. Court of International Trade and to Judge Alan D. Lourie of the U.S. Court of Appeals for the Federal Circuit. Professor Rajec was the Frank H. Marks Visiting Associate Professor and Fellow in Intellectual Property Law at George Washington University Law School and a Lecturer in Law and Teaching Fellow for the Law, Science & Technology Program at Stanford Law School.

Andres Sawicki is a Professor of Law at the University of Miami School of Law. He has a J.D. degree from the University of Chicago, as well as S.B. degrees in Brain & Cognitive Sciences, and in Science, Technology, & Society from the Massachusetts Institute of Technology. After law school, Professor Sawicki clerked for the Honorable Robert Sack of the United States Court of Appeals for the Second Circuit. He then was an intellectual property litigation associate in the New York office of Kirkland & Ellis LLP, where he focused on Hatch-Waxman patent litigation, and a Bigelow Fellow at the University of Chicago Law School.





## Editing Notes

This book is designed to be, primarily, a tool for learning. To this end, we have made a number of editing decisions that make the opinions—or portions of opinions—more readable and accessible. In editing cases, we have deleted parallel citations and also deleted many internal citations entirely. We also sometimes omitted concurrences or dissents without noting the omission. We have cut most footnotes; the ones we've kept have been inserted as block quotes inline with the text, in hopes of making the book more accessible for those who use screen readers. We have also sometimes omitted internal quotation marks where a case quotes another case. We added or otherwise modified some quotation marks where older writing conventions could be confusing. We have taken out editing marks added by courts, e.g., brackets where a court changes the capitalization in a quote. We have occasionally removed italics, changed capitalization, and made other formatting changes for the sake of uniformity and readability. In some cases, we've substituted low-resolution images from a court's decision with higher-resolution versions of those images. We have also standardized the formatting of some case headings, including occasionally omitting text (or other matter) from the headings, to improve readability and uniformity. We also omitted headings entirely. We have generally used ellipses when we cut material from cases (other than citations, parenthetical matter, illustrations, headings or heading matter, and footnotes), except where the omissions come at the beginning of a case excerpt or at the start of a section. We also omitted some ellipses where a paragraph or more was omitted from the end of a case or section, where doing so seemed beneficial for readability or aesthetic reasons. Accordingly, this book should not be used as an authoritative source of case text. If you want to quote these cases, please refer to the official reported versions.



# Table of Contents

1. Introduction .....	17
A. The Patent Balance .....	17
B. The Origins of the Contemporary Patent System .....	28
C. Structure of the U.S. Patent System .....	38
D. The Patent Document .....	43
2. The Invention, the Patent, and the Claim .....	47
3. Patentable Subject Matter.....	75
A. Patentable Subject Matter: The Modern Framework.....	79
B. Patentable Subject Matter: How Did We Get Here? .....	94
C. Applying the Modern Framework.....	133
4. Utility .....	159
A. Credible Utility .....	160
B. Beneficial Utility.....	160
C. Practical Utility .....	165
5. Disclosure.....	185
A. Enablement.....	186
B. Written Description .....	204
C. Definiteness .....	226
D. Best Mode .....	239
6. Novelty .....	243
A. Prior Art: Timing.....	244
B. Prior Art: Categories.....	245
C. Exceptions under § 102(b) .....	282
D. Prior Art: Standards for Anticipation.....	285
E. Comparing Novelty Pre- and Post-AIA .....	293
7. Nonobviousness .....	297
A. From “Invention” to “Nonobviousness” .....	297
A. Nonobviousness Today .....	318
8. Claim Construction.....	363
A. Interpreting Claims.....	363
B. Institutional Dimensions of Claim Construction .....	392
9. Infringement .....	413
A. Direct, Literal Infringement.....	413
B. The Doctrine of Equivalents.....	417
C. Indirect Infringement.....	432
D. Joint Infringement.....	446

E. Cross-border Infringement.....	452
10. Defenses.....	465
A. Inequitable Conduct .....	465
B. Laches .....	474
C. Reverse Doctrine of Equivalents .....	480
D. Experimental Use Defense .....	487
E. Prior User Rights.....	491
F. Exhaustion.....	492
11. Plants.....	503
A. Plant Patents .....	503
B. Plant Variety Protection Act.....	511
C. Utility Patents for Plants.....	518
12. Designs.....	531
A. Scope .....	532
B. Novelty & Nonobviousness .....	554
C. Ornamentality .....	571
D. Disclosure & Priority .....	599
13. Post-Grant Proceedings.....	619
A. The PTAB and the Constitution.....	619
B. Post-Issuance Administrative Review Processes .....	628
C. Institution of Post-Issuance Administrative Proceedings .....	637
D. Post-Issuance Review and Correction.....	648
14. Remedies .....	667
A. Injunctive Relief.....	667
B. Money Damages .....	672
C. Reasonable Royalty .....	678
D. Enhanced Damages and Attorney Fees .....	698

# Table of Cases

1. Introduction .....	17
Bonito Boats, Inc. v. Thunder Craft Boats, Inc. ....	19
2. The Invention, the Patent, and the Claim .....	47
Consolidated Electric Light Co. v. McKeesport Light Co. ....	48
Winans v. Denmead .....	57
Merrill v. Yeomans .....	63
Liebel-Flarsheim Co. v. Medrad, Inc. ....	67
3. Patentable Subject Matter.....	75
Alice Corp. v. CLS Bank Int’l.....	79
Neilson v. Harford .....	96
Le Roy v. Tatham .....	97
O’Reilly v. Morse.....	102
Parke-Davis v. H.K. Mulford.....	107
Funk Bros. Seed Co. v. Kalo Inoculant Co.....	110
Parker v. Flook.....	115
Diamond v. Diehr.....	121
BASCOM Global Internet Services, Inc. v. AT&T Mobility LLC .....	134
McRO, Inc. v. AI Namco Games Am., Inc. ....	143
Ariosa Diagnostics, Inc. v. Sequenom, Inc.....	151
4. Utility .....	159
Lowell v. Lewis.....	161
Juicy Whip, Inc. v. Orange Bang, Inc.....	162
Brenner v. Manson .....	166
In Re Brana .....	171
In re Fisher.....	176
5. Disclosure.....	185
CFMT, Inc. v. YieldUp Int’l Corp.....	187
McRO, Inc. v. Bandai Namco Games Am. Inc. ....	192
Amgen, Inc. v. Chugai Pharm. Co. ....	198
In re Ruschig .....	206
Vas-Cath Inc. v. Mahurkar.....	208
Ariad Pharmaceuticals, Inc. v. Eli Lilly & Co.....	217
Datamize, LLC v. Plumtree Software, Inc. ....	227
Nautilus, Inc. v. Biosig Instruments, Inc.....	234

## CHAPTER 1

6. Novelty .....	243
Medtronic, Inc. v. Barry .....	246
City of Elizabeth v. American Nicholson Pavement Co. ....	253
Egbert v. Lippman.....	256
Moleculon Research Corp. v. CBS, Inc. ....	263
Metallizing Eng'g Co. v. Kenyon Bearing & Auto Parts Co. ....	266
Pfaff v. Wells Electronics, Inc., .....	268
Helsinn Healthcare S.A. v. Teva Pharmaceuticals USA, Inc.....	274
Marrin v. Griffin .....	286
In re Cruciferous Sprout Litigation .....	289
7. Nonobviousness .....	297
Hotchkiss v. Greenwood .....	297
Great Atlantic & Pac. Tea Co. v. Supermarket Equip. Corp. ....	300
Graham v. John Deere Co. ....	306
KSR Int'l Co. v. Teleflex Inc. ....	319
Transocean Offshore Deepwater Drilling, Inc. v. Maersk Drilling USA.....	331
B/E Aerospace, Inc. v. C&D Zodiac, Inc.....	341
Circuit Check Inc. v. QXQ Inc. ....	347
Innovention Toys, LLC v. MGA Entertainment, Inc.....	351
8. Claim Construction.....	363
Phillips v. AWH Corp.....	364
Williamson v. Citrix Online, LLC .....	377
Abbott Laboratories v. Sandoz, Inc. ....	384
Markman v. Westview Instruments, Inc.....	392
Teva Pharmaceuticals, Inc. v. Sandoz, Inc.....	401
Cuozzo Speed Technologies, LLC v. Lee.....	407
9. Infringement .....	413
Larami Corp. v. Amron .....	414
Warner-Jenkinson Company, Inc. v. Hilton Davis Chemical Co. ....	418
Festo Corp. v. Shoketsu Kinzoku Kogyo Kabushiki Co., Ltd.....	424
Aro Manufacturing Co. v. Convertible Top Replacement .....	434
C.R. Bard, Inc. v. Advanced Cardiovascular Systems, Inc.....	441
Limelight Networks, Inc. v. Akamai Technologies, Inc., .....	446
Microsoft, Corp. v. AT&T Corp. ....	453
10. Defenses.....	465
Therasense, Inc. v. Becton, Dickinson and Co.....	465
SCA Hygiene Products Aktiebolag v. First Quality Baby Products, LLC .....	475
Madey v. Duke University .....	487
Quanta Computer, Inc. v. LG Electronics, Inc. ....	493

## INTRODUCTION

11. Plants.....	503
In re Beineke.....	506
AGSouth Genetics, LLC v. Georgia Farm Services, LLC.....	512
J.E.M. Ag Supply, Inc. v. Pioneer Hi-Bred Int'l, Inc. ....	518
12. Designs.....	531
Gorham Co. v. White .....	537
Egyptian Goddess, Inc. v. Swisa, Inc. ....	540
High Point Design LLC v. Buyers Direct, Inc. ....	555
High Point Design LLC v. Buyers Direct, Inc. ....	564
In re Carletti .....	572
In re Webb .....	574
Best Lock Corp. v. Ilco Unican Corp. ....	578
Ethicon Endo-Surgery, Inc. v. Covidien, Inc. ....	587
In re Daniels .....	599
In re Owens .....	605
In re Maatita .....	612
13. Post-Grant Proceedings.....	619
Oil States Energy Services, LLC v. Greene's Energy Group, LLC .....	620
Quantum Corp. v. Rodime, PLC.....	633
Cuozzo Speed Technologies, LLC v. Lee.....	637
SAS Institute Inc. v. Iancu .....	640
Superior Fireplace Co. v. Majestic Products Co.....	648
Mentor Corp. v. Coloplast Inc. ....	654
Seattle Box Co., Inc. v. Industrial Crating & Packing, Inc. ....	658
Allen Archery, Inc. v. Browning Manufacturing Co.....	662
14. Remedies .....	667
eBay v. MercExchange.....	667
BIC Leisure Products, Inc. v. Windsurfing International, Inc. ....	672
Lucent Technologies, Inc. v. Gateway, Inc. ....	678
Samsung Electronics Co., Ltd. v. Apple Inc. ....	695
Octane Fitness, LLC v. ICON Health & Fitness, Inc. ....	699
Halo Electronics, Inc. v. Pulse Electronics, Inc.....	703





# 1. INTRODUCTION

This book is about patents. Patents can be important tools for governments, businesses, and individuals to achieve various goals. Their importance has ebbed and flowed over time; as we write this book, the impact of patents is at a relative high point in a range of social, business, and legal contexts. So you may already have heard activists, journalists, CEOs, lawyers, and politicians talking about why, in their view, patents are desirable or undesirable, what works in the patent system and what doesn't. The purpose of this book is to lay the foundation for you to form your own ideas about how best to use patents, and then to put those ideas into practice.

There are three types of U.S. patents. Utility patents, which have existed since 1790, are available for "any new and useful process, machine, manufacture, or composition of matter, or any new and useful improvement thereof." 35 U.S.C. § 101. Design patents, which have existed since 1842, are available for "any new, original and ornamental design for an article of manufacture." 35 U.S.C. § 171. Plant patents, which have existed since 1930, are available for "any distinct and new variety of plant, including cultivated sports, mutants, hybrids, and newly found seedlings, other than a tuber propagated plant or a plant found in an uncultivated state." 35 U.S.C. § 161. But many people (including judges) use the word "patent" to mean only utility patents. Therefore, this book will do the same unless otherwise indicated.

Patents are one type of legal right in a larger category that is often referred to as "intellectual property" or "IP." Other rights frequently included in this category are copyrights (17 U.S.C. § 101 *et seq.*), trademarks (15 U.S.C. § 1051 *et seq.*), and trade secrets, which are protected through a variety of laws. Although this book will focus on patents, it will also mention these other related areas of law because there are important legal, theoretical, and policy overlaps between them.

## A. The Patent Balance

The Constitution allows Congress to promote progress in the useful arts by granting inventors exclusive, time-limited rights over their discoveries. U.S. CONST. art. I, § 8, cl. 8. The right granted by a patent is the "right to exclude others from making, using, offering for sale, or selling the invention." 35 U.S.C. § 154(a)(1). How does this right to exclude encourage innovation? Limiting competition in the manufacture and sales of a product or the performance of a process gives a patent holder the opportunity to charge a premium price, the size of which will depend on demand for the invention and the availability of

noninfringing substitutes. An inventor can also use a patent to attract investment. An individual inventor might not have manufacturing capacity or might prefer to focus on inventing and not commercialization. A patent allows the inventor to protect their invention and seek investors, licensors, or purchasers of the technology. This is particularly desirable in an area of policy governing innovation, where *ex ante* government valuation is particularly difficult, rendering impractical tools like grants and prizes that depend on such valuation. In addition, patents serve a teaching function to the public and other innovators by requiring a detailed disclosure of the invention. Then, when the patent expires, the invention falls into the public domain and may be exploited by anyone.

The patent grant is supposed to benefit society by spurring innovation that would not have occurred—or would have occurred later—but for the IP incentive. However, there are costs, too, especially including diminished public access to patented inventions during the patent term. This diminished access occurs in three ways. First, higher prices can be extracted from consumers because of the lack of competition in the manufacture and sale of the described invention. In economic terms, patents impose artificial scarcity and result in a deadweight loss to society by increasing consumer costs and decreasing access. *See, e.g.,* Steven Shavell & Tanguy van Ypersele, *Rewards Versus Intellectual Property Rights*, 44 J.L. & ECON. 525, 529 (2001); Amy Kapczynski, *The Cost of Price: Why and How to Get Beyond Intellectual Property Internalism*, 59 UCLA L. REV. 970, 974 (2012). Thomas Jefferson famously recognized this cost in explaining that patents should be granted only for “the things which are worth to the public the embarrassment of an exclusive patent.” *Letter from Thomas Jefferson to Isaac McPherson* (Aug. 13, 1813), in 13 THE WRITINGS OF THOMAS JEFFERSON 326, 333-35 (Andrew A. Lipscomb et al. eds., 1905). Second, improvements to—or other innovations that build on—the patented invention may be delayed or not occur, thus depriving future innovators of the ability to innovate and the public of access to that future innovation. And third, a patent holder may choose not to bring an invention to market at all. The patent grant accordingly must balance the incentives to invent with the interest in access.

The patent system achieves this balance by imposing a series of requirements to obtain a patent and limitations in their scope and enforcement. An invention must be new, useful, and nonobvious in order to merit a patent. It must also claim only eligible subject matter. Moreover, disclosure requirements ensure that the patent will teach other artisans how to use the invention and provide notice of the scope of the patent right. These disclosure rules, along with related rules regarding patent scope, also serve the purposes of giving adequate notice and certainty to consumers and other innovators. Still other doctrines constrain enforcement so that the exclusive rights that patents grant aren't stretched beyond their limits—for example, patentees cannot expand exclusivity beyond

## INTRODUCTION

the term of the patent or improperly tie sales of a patented good to other products. Conversely, there are also statutory provisions and doctrines that expand patent enforcement in order to prevent competitors from avoiding the letter of the patent while still reaping the benefits of the invention.

This book will explore these various doctrines in detail. To start, though, let's explore a "non-patent" case that describes these tradeoffs and requirements in detail. Keep in mind the balance that the patent system is meant to strike as you read the following case.

*Bonito Boats, Inc. v. Thunder Craft Boats, Inc.*  
489 U.S. 141 (1989)

Justice O'CONNOR delivered the opinion of the Court.

We must decide today what limits the operation of the federal patent system places on the States' ability to offer substantial protection to utilitarian and design ideas which the patent laws leave otherwise unprotected. . . .

### I

In September 1976, petitioner Bonito Boats, Inc. (Bonito), a Florida corporation, developed a hull design for a fiberglass recreational boat which it marketed under the trade name Bonito Boat Model 5VBR. Designing the boat hull required substantial effort on the part of Bonito. A set of engineering drawings was prepared, from which a hardwood model was created. The hardwood model was then sprayed with fiberglass to create a mold, which then served to produce the finished fiberglass boats for sale. The 5VBR was placed on the market sometime in September 1976. There is no indication in the record that a patent application was ever filed for protection of the utilitarian or design aspects of the hull, or for the process by which the hull was manufactured. The 5VBR was favorably received by the boating public, and "a broad interstate market" developed for its sale.

In May 1983, after the Bonito 5VBR had been available to the public for over six years, the Florida Legislature enacted Fla. Stat. § 559.94 (1987). The statute makes "it unlawful for any person to use the direct molding process to duplicate for the purpose of sale any manufactured vessel hull or component part of a vessel made by another without the written permission of that other person." § 559.94(2). The statute also makes it unlawful for a person to "knowingly sell a vessel hull or component part of a vessel duplicated in violation of subsection (2)." § 559.94(3). Damages, injunctive relief, and attorney's fees are made available to "any person who suffers injury or damage as the result of a violation" of the statute. § 559.94(4). The statute was made applicable to vessel hulls or component parts duplicated through the use of direct molding after July 1, 1983. § 559.94(5).

## CHAPTER 1

On December 21, 1984, Bonito filed this action in the Circuit Court of Orange County, Florida. The complaint alleged that respondent here, Thunder Craft Boats, Inc. (Thunder Craft), a Tennessee corporation, had violated the Florida statute by using the direct molding process to duplicate the Bonito 5VBR fiberglass hull, and had knowingly sold such duplicates in violation of the Florida statute. Bonito sought “a temporary and permanent injunction prohibiting Thunder Craft from continuing to unlawfully duplicate and sell Bonito Boat hulls or components,” as well as an accounting of profits, treble damages, punitive damages, and attorney’s fees. . . .

On appeal, a sharply divided Florida Supreme Court agreed with the lower courts’ conclusion that the Florida law impermissibly interfered with the scheme established by the federal patent laws. . . .

### II

Article I, § 8, cl. 8, of the Constitution gives Congress the power “to promote the Progress of Science and useful Arts, by securing for limited Times to Authors and Inventors the exclusive Right to their respective Writings and Discoveries.” The Patent Clause itself reflects a balance between the need to encourage innovation and the avoidance of monopolies which stifle competition without any concomitant advance in the “Progress of Science and useful Arts.” As we have noted in the past, the Clause contains both a grant of power and certain limitations upon the exercise of that power. Congress may not create patent monopolies of unlimited duration, nor may it “authorize the issuance of patents whose effects are to remove existent knowledge from the public domain, or to restrict free access to materials already available.”

From their inception, the federal patent laws have embodied a careful balance between the need to promote innovation and the recognition that imitation and refinement through imitation are both necessary to invention itself and the very lifeblood of a competitive economy. Soon after the adoption of the Constitution, the First Congress enacted the Patent Act of 1790, which allowed the grant of a limited monopoly of 14 years to any applicant that “hath invented or discovered any useful art, manufacture, or device, or any improvement therein not before known or used.” In addition to novelty, the 1790 Act required that the invention be “sufficiently useful and important” to merit the 14-year right of exclusion. Section 2 of the Act required that the patentee deposit with the Secretary of State, a specification and if possible a model of the new invention, “which specification shall be so particular, and said models so exact, as not only to distinguish the invention or discovery from other things before known and used, but also to enable a workman or other person skilled in the art or manufacture to make, construct, or use the same, to the end that the public may have the full benefit thereof, after the expiration of the patent term.”

## INTRODUCTION

The first Patent Act established an agency known by self-designation as the “Commissioners for the promotion of Useful Arts,” composed of the Secretary of State, the Secretary of the Department of War, and the Attorney General, any two of whom could grant a patent. Thomas Jefferson was the first Secretary of State, and the driving force behind early federal patent policy. For Jefferson, a central tenet of the patent system in a free market economy was that “a machine of which we were possessed, might be applied by every man to any use of which it is susceptible.” He viewed a grant of patent rights in an idea already disclosed to the public as akin to an *ex post facto* law, “obstructing others in the use of what they possessed before.” Jefferson also played a large role in the drafting of our Nation’s second Patent Act, which became law in 1793. The Patent Act of 1793 carried over the requirement that the subject of a patent application be “not known or used before the application.” A defense to an infringement action was created where “the thing, thus secured by patent, was not originally discovered by the patentee, but had been in use, or had been described in some public work anterior to the supposed discovery of the patentee.” Thus, from the outset, federal patent law has been about the difficult business “of drawing a line between the things which are worth to the public the embarrassment of an exclusive patent, and those which are not.”

Today’s patent statute is remarkably similar to the law as known to Jefferson in 1793. Protection is offered to “whoever invents or discovers any new and useful process, machine, manufacture, or composition of matter, or any new and useful improvement thereof.” 35 U.S.C. § 101. Since 1842, Congress has also made protection available for “any new, original and ornamental design for an article of manufacture.” 35 U.S.C. § 171. To qualify for protection, a design must present an aesthetically pleasing appearance that is not dictated by function alone, and must satisfy the other criteria of patentability. The novelty requirement of patentability is presently expressed in 35 U.S.C. §§ 102(a) and (b), which provide:

A person shall be entitled to a patent unless-

- (a) the invention was known or used by others in this country, or patented or described in a printed publication in this or a foreign country, before the invention thereof by the applicant for patent, or
- (b) the invention was patented or described in a printed publication in this or a foreign country or in public use or on sale in this country more than one year prior to the date of application for patent in the United States.

Sections 102(a) and (b) operate in tandem to exclude from consideration for patent protection knowledge that is already available to the public. They express a congressional determination that the creation of a monopoly in such information would not only serve no socially useful purpose, but would in fact injure the public by removing existing

## CHAPTER 1

knowledge from public use. From the Patent Act of 1790 to the present day, the public sale of an unpatented article has acted as a complete bar to federal protection of the idea embodied in the article thus placed in public commerce.

In the case of *Pennock v. Dialogue*, 2 Pet. 1 (1829), Justice Story applied these principles under the patent law of 1800. The patentee had developed a new technique for the manufacture of rubber hose for the conveyance of air and fluids. The invention was reduced to practice in 1811, but letters patent were not sought and granted until 1818. In the interval, the patentee had licensed a third party to market the hose, and over 13,000 feet of the new product had been sold in the city of Philadelphia alone. The Court concluded that the patent was invalid due to the prior public sale, indicating that, “if an inventor suffers the thing he invented to go into public use, or to be publicly sold for use” “his voluntary act or acquiescence in the public sale and use is an abandonment of his right.” The Court noted that under the common law of England, letters patent were unavailable for the protection of articles in public commerce at the time of the application, and that this same doctrine was immediately embodied in the first patent laws passed in this country.

As the holding of *Pennock* makes clear, the federal patent scheme creates a limited opportunity to obtain a property right in an idea. Once an inventor has decided to lift the veil of secrecy from his work, he must choose the protection of a federal patent or the dedication of his idea to the public at large. As Judge Learned Hand once put it: “It is a condition upon the inventor's right to a patent that he shall not exploit his discovery competitively after it is ready for patenting; he must content himself with either secrecy or legal monopoly.” *Metallizing Engineering Co. v. Kenyon Bearing & Auto Parts Co.*, 153 F.2d 516, 520 (2d Cir. 1946).

In addition to the requirements of novelty and utility, the federal patent law has long required that an innovation not be anticipated by the prior art in the field. Even if a particular combination of elements is “novel” in the literal sense of the term, it will not qualify for federal patent protection if its contours are so traced by the existing technology in the field that the “improvement is the work of the skillful mechanic, not that of the inventor.” *Hotchkiss v. Greenwood*, 11 How. 248, 267 (1851). In 1952, Congress codified this judicially developed requirement in 35 U.S.C. § 103, which refuses protection to new developments where “the differences between the subject matter sought to be patented and the prior art are such that the subject matter as a whole would have been obvious at the time the invention was made to a person of ordinary skill in the art to which said subject matter pertains.” The nonobviousness requirement extends the field of unpatentable material beyond that which is known to the public under § 102, to include that which could readily be deduced from publicly available material by a person of ordinary skill in the pertinent field of endeavor. Taken together, the novelty and

## INTRODUCTION

nonobviousness requirements express a congressional determination that the purposes behind the Patent Clause are best served by free competition and exploitation of either that which is already available to the public or that which may be readily discerned from publicly available material.

The applicant whose invention satisfies the requirements of novelty, nonobviousness, and utility, and who is willing to reveal to the public the substance of his discovery and “the best mode of carrying out his invention,” 35 U.S.C. § 112, is granted “the right to exclude others from making, using, or selling the invention throughout the United States,” for a period of 17 years. 35 U.S.C. § 154. The federal patent system thus embodies a carefully crafted bargain for encouraging the creation and disclosure of new, useful, and nonobvious advances in technology and design in return for the exclusive right to practice the invention for a period of years. “The inventor may keep his invention secret and reap its fruits indefinitely. In consideration of its disclosure and the consequent benefit to the community, the patent is granted. An exclusive enjoyment is guaranteed him for seventeen years, but upon expiration of that period, the knowledge of the invention inures to the people, who are thus enabled without restriction to practice it and profit by its use.”

The attractiveness of such a bargain, and its effectiveness in inducing creative effort and disclosure of the results of that effort, depend almost entirely on a backdrop of free competition in the exploitation of unpatented designs and innovations. The novelty and nonobviousness requirements of patentability embody a congressional understanding, implicit in the Patent Clause itself, that free exploitation of ideas will be the rule, to which the protection of a federal patent is the exception. Moreover, the ultimate goal of the patent system is to bring new designs and technologies into the public domain through disclosure. State law protection for techniques and designs whose disclosure has already been induced by market rewards may conflict with the very purpose of the patent laws by decreasing the range of ideas available as the building blocks of further innovation. The offer of federal protection from competitive exploitation of intellectual property would be rendered meaningless in a world where substantially similar state law protections were readily available. To a limited extent, the federal patent laws must determine not only what is protected, but also what is free for all to use.

Thus our past decisions have made clear that state regulation of intellectual property must yield to the extent that it clashes with the balance struck by Congress in our patent laws. The tension between the desire to freely exploit the full potential of our inventive resources and the need to create an incentive to deploy those resources is constant. Where it is clear how the patent laws strike that balance in a particular circumstance, that is not a judgment the States may second-guess. We have long held that after the expiration of a federal patent, the subject matter of the patent passes to the free use of the public as a matter of federal law. Where the public has paid the congressionally mandated price for

## CHAPTER 1

disclosure, the States may not render the exchange fruitless by offering patent-like protection to the subject matter of the expired patent. "It is self-evident that on the expiration of a patent the monopoly created by it ceases to exist, and the right to make the thing formerly covered by the patent becomes public property."

In our decisions in *Sears, Roebuck & Co. v. Stiffel Co.*, 376 U.S. 225 (1964), and *Compco Corp. v. Day-Brite Lighting, Inc.*, 376 U.S. 234 (1964), we found that publicly known design and utilitarian ideas which were unprotected by patent occupied much the same position as the subject matter of an expired patent. The *Sears* case involved a pole lamp originally designed by the plaintiff Stiffel, who had secured both design and mechanical patents on the lamp. Sears purchased unauthorized copies of the lamps, and was able to sell them at a retail price practically equivalent to the wholesale price of the original manufacturer. Stiffel brought an action against Sears in Federal District Court, alleging infringement of the two federal patents and unfair competition under Illinois law. The District Court found that Stiffel's patents were invalid due to anticipation in the prior art, but nonetheless enjoined Sears from further sales of the duplicate lamps based on a finding of consumer confusion under the Illinois law of unfair competition. . . .

This Court reversed, finding that the unlimited protection against copying which the Illinois law accorded an unpatentable item whose design had been fully disclosed through public sales conflicted with the federal policy embodied in the patent laws. . . .

A similar conclusion was reached in *Compco*, where the District Court had extended the protection of Illinois' unfair competition law to the functional aspects of an unpatented fluorescent lighting system. The injunction against copying of an unpatented article, freely available to the public, impermissibly "interfered with the federal policy, found in Art. I, § 8, cl. 8, of the Constitution and in the implementing federal statutes, of allowing free access to copy whatever the federal patent and copyright laws leave in the public domain."

. . . Read at their highest level of generality, the two decisions could be taken to stand for the proposition that the States are completely disabled from offering any form of protection to articles or processes which fall within the broad scope of patentable subject matter. Since the potentially patentable includes "anything under the sun that is made by man," *Diamond v. Chakrabarty*, 447 U.S. 303, 309 (1980), the broadest reading of *Sears* would prohibit the States from regulating the deceptive simulation of trade dress or the tortious appropriation of private information.

That the extrapolation of such a broad pre-emptive principle from *Sears* is inappropriate is clear from the balance struck in *Sears* itself. The *Sears* Court made it plain that the States "may protect businesses in the use of their trademarks, labels, or distinctive dress in the packaging of goods so as to prevent others, by imitating such markings, from



## INTRODUCTION

misleading purchasers as to the source of the goods.” Trade dress is, of course, potentially the subject matter of design patents. Yet our decision in *Sears* clearly indicates that the States may place limited regulations on the circumstances in which such designs are used in order to prevent consumer confusion as to source. Thus, while *Sears* speaks in absolutist terms, its conclusion that the States may place some conditions on the use of trade dress indicates an implicit recognition that all state regulation of potentially patentable but unpatented subject matter is not *ipso facto* pre-empted by the federal patent laws.

What was implicit in our decision in *Sears*, we have made explicit in our subsequent decisions concerning the scope of federal pre-emption of state regulation of the subject matter of patent. Thus, in *Kewanee Oil Co. v. Bicron Corp.*, 416 U.S. 470 (1974), we held that state protection of trade secrets did not operate to frustrate the achievement of the congressional objectives served by the patent laws. Despite the fact that state law protection was available for ideas which clearly fell within the subject matter of patent, the Court concluded that the nature and degree of state protection did not conflict with the federal policies of encouragement of patentable invention and the prompt disclosure of such innovations.

Several factors were critical to this conclusion. First, because the public awareness of a trade secret is by definition limited, the Court noted that “the policy that matter once in the public domain must remain in the public domain is not incompatible with the existence of trade secret protection.” Second, the *Kewanee* Court emphasized that “trade secret law provides far weaker protection in many respects than the patent law.” This point was central to the Court’s conclusion that trade secret protection did not conflict with either the encouragement or disclosure policies of the federal patent law. The public at large remained free to discover and exploit the trade secret through reverse engineering of products in the public domain or by independent creation. Thus, the possibility that trade secret protection would divert inventors from the creative effort necessary to satisfy the rigorous demands of patent protection was remote indeed. Finally, certain aspects of trade secret law operated to protect non-economic interests outside the sphere of congressional concern in the patent laws. As the Court noted, “A most fundamental human right, that of privacy, is threatened when industrial espionage is condoned or is made profitable.” There was no indication that Congress had considered this interest in the balance struck by the patent laws, or that state protection for it would interfere with the policies behind the patent system.

...

At the heart of *Sears* and *Compco* is the conclusion that the efficient operation of the federal patent system depends upon substantially free trade in publicly known, unpatented design and utilitarian conceptions. In *Sears*, the state law offered “the equivalent of a patent monopoly,” in the functional aspects of a product which had been

## CHAPTER 1

placed in public commerce absent the protection of a valid patent. . . . [W]e believe that the *Sears* Court correctly concluded that the States may not offer patent-like protection to intellectual creations which would otherwise remain unprotected as a matter of federal law. Both the novelty and the nonobviousness requirements of federal patent law are grounded in the notion that concepts within the public grasp, or those so obvious that they readily could be, are the tools of creation available to all. They provide the baseline of free competition upon which the patent system's incentive to creative effort depends. A state law that substantially interferes with the enjoyment of an unpatented utilitarian or design conception which has been freely disclosed by its author to the public at large impermissibly contravenes the ultimate goal of public disclosure and use which is the centerpiece of federal patent policy. Moreover, through the creation of patent-like rights, the States could essentially redirect inventive efforts away from the careful criteria of patentability developed by Congress over the last 200 years. We understand this to be the reasoning at the core of our decisions in *Sears* and *Compco*, and we reaffirm that reasoning today.

### III

We believe that the Florida statute at issue in this case so substantially impedes the public use of the otherwise unprotected design and utilitarian ideas embodied in unpatented boat hulls as to run afoul of the teaching of our decisions in *Sears* and *Compco*. It is readily apparent that the Florida statute does not operate to prohibit "unfair competition" in the usual sense that the term is understood. The law of unfair competition has its roots in the common-law tort of deceit: its general concern is with protecting consumers from confusion as to source. While that concern may result in the creation of "quasi-property rights" in communicative symbols, the focus is on the protection of consumers, not the protection of producers as an incentive to product innovation. . . .

. . .

In contrast to the operation of unfair competition law, the Florida statute is aimed directly at preventing the exploitation of the design and utilitarian conceptions embodied in the product itself. The sparse legislative history surrounding its enactment indicates that it was intended to create an inducement for the improvement of boat hull designs. See Tr. of Meeting of Transportation Committee, Florida House of Representatives, May 3, 1983 ("There is no inducement for a quality boat manufacturer to improve these designs and secondly, if he does, it is immediately copied. This would prevent that and allow him recourse in circuit court"). To accomplish this goal, the Florida statute endows the original boat hull manufacturer with rights against the world, similar in scope and operation to the rights accorded a federal patentee. Like the patentee, the beneficiary of the Florida statute may prevent a competitor from "making" the product in what is evidently the most efficient manner available and from "selling" the product when it is produced in

## INTRODUCTION

that fashion. The Florida scheme offers this protection for an unlimited number of years to all boat hulls and their component parts, without regard to their ornamental or technological merit. Protection is available for subject matter for which patent protection has been denied or has expired, as well as for designs which have been freely revealed to the consuming public by their creators.

In this case, the Bonito 5VBR fiberglass hull has been freely exposed to the public for a period in excess of six years. For purposes of federal law, it stands in the same stead as an item for which a patent has expired or been denied: it is unpatented and unpatentable. Whether because of a determination of unpatentability or other commercial concerns, petitioner chose to expose its hull design to the public in the marketplace, eschewing the bargain held out by the federal patent system of disclosure in exchange for exclusive use. Yet, the Florida statute allows petitioner to reassert a substantial property right in the idea, thereby constricting the spectrum of useful public knowledge. Moreover, it does so without the careful protections of high standards of innovation and limited monopoly contained in the federal scheme. We think it clear that such protection conflicts with the federal policy “that all ideas in general circulation be dedicated to the common good unless they are protected by a valid patent.”

...

Congress has considered extending various forms of limited protection to industrial design either through the copyright laws or by relaxing the restrictions on the availability of design patents. Congress explicitly refused to take this step in the copyright laws, and despite sustained criticism for a number of years, it has declined to alter the patent protections presently available for industrial design. It is for Congress to determine if the present system of design and utility patents is ineffectual in promoting the useful arts in the context of industrial design. By offering patent-like protection for ideas deemed unprotected under the present federal scheme, the Florida statute conflicts with the “strong federal policy favoring free competition in ideas which do not merit patent protection.” We therefore agree with the majority of the Florida Supreme Court that the Florida statute is preempted by the Supremacy Clause, and the judgment of that court is hereby affirmed.

## Context and Application

1. In *Bonito Boats*, the Court describes patent law as embodying “a carefully crafted bargain.” Who are the parties to this bargain? What is given and what is gained by each?

## CHAPTER 1

2. *Bonito Boats* is not a patent infringement case. However, it describes the requirements of the patent system in detail. What are the requirements the Court discusses for getting a patent, and what are the purposes of each of these requirements?

3. Patents are not the only way to encourage innovation. There are other mechanisms, such as grants, tax relief, and prizes that also serve to encourage innovation at various stages. We might ask whether patents are the best—or even a good—way to encourage innovation. This is a difficult question to measure empirically. British economist Edith Penrose concluded that “[i]f national patent laws did not exist, it would be difficult to make a conclusive case for introducing them; but the fact that they do exist shifts the burden of proof and it is equally difficult to make a really conclusive case for abolishing them.” EDITH TILTON PENROSE, *THE ECONOMICS OF THE INTERNATIONAL PATENT SYSTEM* 40 (1951). Fritz Machlup echoed this sentiment in remarks he submitted to the Senate Judiciary Committee, stating that “[i]f we did not have a patent system, it would be irresponsible, on the basis of our present knowledge of its economic consequences, to recommend instituting one. But since we have had a patent system for a long time, it would be irresponsible, on the basis of our present knowledge, to recommend abolishing it.” Staff of Subcomm. on Patents, Trademarks & Copyrights of the S. Comm. on the Judiciary, 85th Cong., *An Economic Review of the Patent System*, Study No. 15, at 79-80 (Comm. Print 1958). As you read the cases in this book, consider when the patent system seems to best work in encouraging innovation—is it for early-stage inventions or later-stage commercialization? Mechanical inventions, biotech, or software innovations? How do the various statutory provisions and doctrinal developments affect different-sized innovators, and do these distinctions matter to the overarching goals of the system?

### B. The Origins of the Contemporary Patent System

As *Bonito Boats* reveals, patent law didn’t suddenly appear fully formed, and it doesn’t exist in some abstract idealized space; instead, it has a rich history, is embedded in a deep social context, and is part of a larger legal regime. This section will provide a brief overview of this history and context, starting with the fact that patents are only one among several tools that governments have long employed to encourage technological innovation—prizes are one such example. In 1567, Phillip II of Spain offered a prize for finding a simple way to reliably determine a ship’s longitude at sea. While no one was able to claim that reward (or several subsequent similar prizes in Spain and the Netherlands), the English Parliament in 1714 enacted the Longitude Act, which established the Board of Longitude to administer prizes for the same purpose, and which ultimately produced some viable solutions. In the early 1800s, Napoleon offered a prize for technology that would help deliver food to distant military troops; this led to the development of canned food. And today, the America COMPETES Reauthorization Act

## INTRODUCTION

of 2010 has established broad authority for federal agencies to use prizes to stimulate advances in science and technology. Our study of the patent system should accordingly bear in mind how it compares to plausible alternatives, including not only prizes, but also trade secrets, contracts, grants, subsidies, and a range of other private and public mechanisms. See Daniel J. Hemel & Lisa Larrimore Ouellette, *Innovation Policy Pluralism*, 128 YALE L.J. 544 (2019); cf. Alex Bell, Raj Chetty, Xavier Jaravel, Neviana Petkova, & John Van Reenen, *Who Becomes an Inventor in America? The Importance of Exposure to Innovation*, 134 Q.J. ECON. 647 (2019) (demonstrating, from a dataset including 1.2 million inventors, that children “who grow up in a neighborhood or family with a high innovation rate in a specific technology class are more likely to patent in exactly the same class,” and that for girls, this effect depends on the concentration of women inventors, suggesting that role-model and network effects are important mechanisms influencing the odds of becoming an inventor).

The origins of something like the modern American patent system is typically traced to Renaissance Italy. See Max Frumkin, *The Origins of Patents*, 27 J. PAT. OFF. SOC'Y 143 (1945). In 1421, Filippo Bruneschelli, who built Il Duomo, received from the Florentine state three years of exclusivity for his device for transporting heavy loads on rivers; he remains today the earliest recorded patentee (that is, the first person to whom a government granted an exclusive right to use or sell some novel process or device they created). Venice then enacted the Venetian Patent Statute of 1474, which is now recognized as the first “general patent statute—namely, one covering more than a single grant.” See Ted Sichelman & Sean O'Connor, *Patents as Promoters of Competition: The Guild Origins of Patent Law in the Venetian Republic*, 49 SAN DIEGO L. REV. 1278 (2012); see also Stefani Fusco, *Lessons from the Past: The Venetian Republic's Tailoring of Patent Protection to the Characteristics of the Invention*, 17 NW. J. TECH. & INTELL. PROP. 301 (2020) (describing the Venetian Senate's continued practice of issuing tailored protection to individual inventions for centuries following the enactment of the general Venetian patent statute). The Venetian system incorporated several features that resemble our own, including the requirement that the subject matter of the patent be “new” and that the exclusive rights be limited in time. As Venetian artisans moved to other countries, they sought similar exclusive rights from governments throughout Europe in the 1500s. See Robert P. Merges, *From Medieval Guilds to Open Source Software: Informal Norms, Appropriability Institutions, and Innovation*, 11-13 (Feb. 2, 2005), available at <https://ssrn.com/abstract=661543> (describing how guilds interacted with emerging patent systems during the Renaissance).

One of those nations, of course, served as the primary source for the American legal system: England. Through much of the sixteenth and seventeenth centuries, English monarchs granted to the politically well-connected exclusive rights to engage in various kinds of commercial activities. These monopolies were awarded in official documents,

addressed and made open to the public; along with other grants made in such documents, they were referred to as letters patent (that is, *litterae patentes*, derived from the Latin “patere,” meaning “to be open”). Importantly, while some of these patents were patents of invention, there was no requirement that the subject of the monopoly be at all new; the monopolies could encompass any product or process, including well-known and long-used ones. Over time, public opposition to these monopolies grew because of their perceived conflict with the Magna Carta’s guarantee that the crown could not withdraw public rights, including the right to engage in commerce, and because of the exorbitant prices that patentees charged. See MOY’S WALKER ON PATENTS §§ 1:3-1:7.

This public opposition culminated in Parliament’s passage of the Statute of Monopolies in 1623. See Edward C. Walterscheid, *To Promote the Progress of Science and Useful Arts: The Background and Origin of the Intellectual Property Clause of the United States Constitution*, 2 J. INTELL. PROP. L. 1 (1994). The Statute of Monopolies declared that exclusive rights to buy, sell, make, or use “any thinge within this Realme” shall be void. 21 Jam. 1, ch. 3, § 1 (1623). The statute’s general ban on monopolies contained a crucial exception: the monarch could award grants of exclusivity for no more than 14 years to “the sole working or makinge of any manner of new Manufactures within this Realme, to the true and first Inventor and Inventors of such Manufactures.” *Id.* § 6. The Statute of Monopolies is typically identified as the foundation for the American patent system, see MOY, *supra*, § 1:6, although there is some debate about the extent to which the Statute of Monopolies represented a break with past practice or a continuation of it, compare OREN BRACHA, *OWNING IDEAS*, ch. 1 (2001) (arguing that the Statute of Monopolies should be understood as a continuation of the preexisting royal prerogative to award discretionary grants of exclusivity, simply in a more circumscribed area), with Adam Mossoff, *Rethinking the Development of Patents: An Intellectual History 1550-1800*, 52 HASTINGS L.J. 1255 (2001) (arguing that the Statute of Monopolies should be viewed as “the first definitive step toward the shift away from royal prerogative and privileges to common law and legal rights”).

The American colonies engaged in something like the English practice. Colonial legislatures (rather than monarchs) issued one-off, discretionary privileges consisting of the exclusive right to engage in some kind of commerce. In the 1600s, some colonial bodies adopted provisions that resembled the Statute of Monopolies, limiting the permissible range of exclusivity to inventions. After the Revolutionary War, the states began to more frequently issue patents to rebuild the post-war economy. In 1784, South Carolina enacted the first American general patent law, providing that “Inventors of useful machines shall have the exclusive privilege of making or vending their machines for . . . terms of 14 years.” This period also saw a shift from a concept of invention grounded in the

## INTRODUCTION

introduction of a new trade or business to one grounded in something like technological progress. *See BRACHA, supra.*

The Constitutional Convention established the foundation for the current American patent system. Article I, Section 8, Clause 8 of the Constitution grants Congress the power “To promote the Progress of Science and useful Arts, by securing for limited Times to Authors and Inventors the exclusive Rights to their respective Writings and Discoveries.” Even though some of the most prominent political figures of the founding era, like Benjamin Franklin and Thomas Jefferson, were also prominent inventors themselves, this clause—now referred to by various names, including, among others, “the IP Clause” and “the Progress Clause”—was not the subject of much debate. However, James Madison’s notes indicate that an earlier version of the clause would have granted Congress the power to “establish public institutions, rewards and immunities for the promotion of agriculture, commerce, trades and manufactures” in addition to the power to “grant patents for useful inventions.” Those additional powers, however, did not make it into the Progress Clause (of course, there are other clauses in the Constitution; can you think of any that might grant Congress the power to do these things even if the Progress Clause doesn’t?).

Despite the relative paucity of attention paid to the Progress Clause at the Convention, the first Congress acted quickly to exercise its powers, enacting the Patent Act of 1790 on April 10 of that year. The 1790 Patent Act permitted “any person” who “invented or discovered any useful art, manufacture, engine, machine, or device, or any improvement therein not before known or used” to apply to the Secretary of State, the Secretary of War, and the Attorney General for a patent. If two of those three deemed “the invention or discovery sufficiently useful and important,” they could issue a patent granting the inventor “for any term not exceeding fourteen years, the sole and exclusive right” to make, construct, use, or sell the invention. Today, we call this type of patent a “utility patent.”

Pursuant to the 1790 Act, the inventor had to provide “a specification in writing, containing a description, accompanied with drafts or models, and explanations and models . . . of the thing . . . invented or discovered . . . ; which specification shall be so particular, and said models so exact, as not only to distinguish the invention or discovery from other things before known and used, but also to enable a workman or other person skilled in the art or manufacture, whereof it is a branch, or wherewith it may be nearest connected, to make, construct, or use the same, to the end that the public may have the full benefit thereof, after the expiration of the patent term.” The first patent under the 1790 Act issued on July 31, 1790 to Samuel Hopkins for a new method of making potash, an important industrial chemical that had been used for centuries and continues to be used as fertilizer.

The Constitution did not explicitly make this congressional authority exclusive of the states, and, indeed, states continued to issue their own patents following the Patent Act

## CHAPTER 1

of 1790. See Camilla A. Hrdy, *State Patents in the Age of Laissez Faire*, 28 BERKELEY TECH. L.J. 45 (2013). This practice largely (though not entirely) came to a close with the Patent Act of 1793, which required that inventors “relinquish” rights obtained from states prior to the ratification of the Constitution before obtaining rights under the Patent Act. The statutory silence with respect to rights obtained from states following ratification might be understood to reflect an assumption that states could not issue state patents following ratification or a choice to permit states to continue issuing state patents. See Hrdy, *id.* at 73. Either way, state patents soon fell out of favor and Supreme Court doctrine now preempts state patents. See *Bonito Boats, Inc. v. Thundercraft Boats, Inc.*, 489 U.S. 141 (1989).

The 1793 Patent Act also launched a radical, though short-lived, transformation from an examination-based patent system to a registration-based one. Only fifty-seven patents had issued in the three years of the 1790 Act; Thomas Jefferson (Secretary of State), Henry Knox (Secretary of War), and Edmund Randolph (Attorney General) deemed the examination of applications for patents an oppressive distraction from their other, more important responsibilities. The 1793 Patent Act accordingly made the Executive Branch role ministerial—patents issued upon application, without examination of their compliance with the substantive requirements of patentability. This rendered the American patent system a registration rather than examination system, with an important collateral consequence: the courts became the primary enforcers of the patent statute’s substantive requirements.

In this role, the American patent system took on a common law character, which has persisted to this day. Under the 1793 Patent Act, this manifested primarily in the requirement that patents be issued only for “useful” inventions, which became the locus for judicial consideration of whether patents served the public interest. Judges, much as English monarchs and colonial governments once did, engaged in a case-by-case assessment of the social impact of the invention covered by the patent. See BRACHA, *supra*. This broad inquiry faded in the wake of Justice Story’s 1817 opinion in *Lowell v. Lewis*, which sharply circumscribed the scope of the utility requirement. The *Lowell* view of utility asked only whether the invention was “mischevious” or “immoral,” like “a new invention to poison people, or to promote debauchery, or to facilitate private assassination.” The only assessment of the invention’s value would come from the market—if an invention lacked utility, then it would be “of little or no profit to the inventor” and “will sink into utter neglect.”

Congress soon reshaped the patent system again with the 1836 Patent Act, which established the entity that administers the current patent system: the Patent Office (now the Patent and Trademark Office, or PTO), staffed with professional patent examiners. The shift away from the registration system of the 1793 Act and back to an examination system (although one quite unlike the 1790 Act’s examination system) was part of a more



## INTRODUCTION

general reaction in the Jacksonian era against a conservative judiciary and against exclusive privileges secured by elites from the government. *See* Herbert Hovenkamp, *The Emergence of Classical American Patent Law*, 58 ARIZ. L. REV. 263 (2016).

Importantly, the Patent Office's examination was intended to be a relatively strict and objective evaluation of whether the invention complied with a newly-elaborated statutory requirement of novelty, rather than the more discretionary and holistic assessment that occurred under the 1790 Act of whether the invention was useful. The 1790 and 1793 Acts had stated simply that the invention be "not before known or used." The Patent Act of 1836 expanded on that language, demanding now that the invention be "not known or used by others before his or their discovery or invention thereof, and not, at the time of his application for a patent, in public use or on sale, with his consent or allowance." Under the 1793 Act, patent applicants had begun including language in their specifications that purported to "claim" the invention; this practice was made a statutory requirement under the 1836 Act, which required that the specification "particularly specify and point out the part, improvement, or combination, which he claims as his own invention or discovery." Those claims would grow into essential elements of the patent system, as courts gradually began to focus their assessments of validity and infringement on the language in the claims.

In the following decades, however, the Supreme Court asserted its role as the leading expositor of patent law. In *Hotchkiss v. Greenwood* 52 U.S. 248 (1850), the Court established the nonobviousness requirement, which demands that the invention be not merely new, but that it be meaningfully different from what existed before it. Soon after this, the Court decided *Le Roy v. Tatham*, 55 U.S. 156 (1852) and *O'Reilly v. Morse*, 56 U.S. 62 (1853), which have become the foundation for judicial exclusions to the scope of patentable subject matter. And *Winans v. Denmead* 56 U.S. 330 (1853) made clear that the scope of a patentee's rights extended beyond the literal words of the claim to reach substantial equivalents of the claimed invention.

Of course, Congress did not sit idle during this period. The Patent Act of 1839 allowed disappointed applicants to seek judicial review of Patent Office determinations. It also added a novelty "grace period," which gave inventors two years during which "purchase, sale, or use" of the invention that would otherwise bar an application would have no effect.

Congress also established a new kind of patent—the design patent—in 1842. That statute permitted the issuance of patents to anyone who "invented or produced any new and original design for a manufacture, whether of metal or other material or materials, or any new and original design for the printing of woolen, silk, cotton, or other fabrics, or any new and original design for a bust, statue, or bas relief or composition in alto or basso relievo, or any new and original impression or ornament, or to be placed on any article of

## CHAPTER 1

manufacture, the same being formed in marble or other material, or any new and useful pattern, or print, or picture, to be either worked into or worked on, or printed or painted or cast or otherwise fixed on, any article of manufacture, or any new and original shape or configuration of any article of manufacture not known or used by others before his, her, or their invention or production thereof.”

The Patent Act of 1870 consolidated these and other post-1836 enactments into a comprehensive provision. It also reaffirmed the Patent Office’s then-recent transition from central claiming to a peripheral claiming system, which treated the claim as setting the outermost boundaries of the patentee’s rights.

The mid-1800s saw patents begin to attain a central social and economic role; applications and grants tripled over the course of the 1850s. The core conflicts of the Civil War era were also reflected in the development of patent law. In 1858, Jeremiah Black, who served as Attorney General under President James Buchanan, issued his opinion in *Invention of a Slave* in the wake of *Dred Scott v. Sandford*. In it, Black concluded that neither slaves nor their owners could obtain patents on inventions created by slaves; by extension, free African Americans were also barred from the patent system they had previously been able to use. Three years later, Edward Bates, Attorney General under President Abraham Lincoln (who, incidentally, was the only president to patent one of his inventions), concluded that “all natural-born Americans regardless of color or race were citizens,” contra *Dred Scott*. That conclusion, along with the Reconstruction Amendments and civil rights legislation abolishing slavery, made *Invention of a Slave* obsolete. The opinion nevertheless continued to play an important role in post-Civil War narratives of African American civil rights activists. See Kara W. Swanson, *Race and Selective Legal Memory: Reflections on Invention of a Slave*, 120 COLUM. L. REV. 1077 (2020) (describing how, during the twentieth century, civil rights advocates relied on patents as evidence of inventive ability and independent thought, which justified equal voting rights for African-Americans).

Patents became essential elements of economic and technological development during the late nineteenth century. Joseph Glidden obtained a patent on his version of barbed wire, which went on to transform the American West. Alexander Graham Bell prevailed over Elisha Gray in an epic race—still the subject of much intrigue—to patent the telephone in 1876. Thomas Edison made patents core to his research and commercial strategy, both using disclosures to further his laboratory’s work and obtaining over 1000 patents himself, on inventions ranging from the phonograph to the lightbulb. More humble products that are part of the everyday fabric of life, like the paper clip and the zipper, were also patented before 1900; a total of 600,000 patents issued between 1865 and 1900. In this period, patents took on a more prominent international profile with the

## INTRODUCTION

creation of the Paris Convention for the Protection of Industrial Property, to which the United States acceded in 1887.

This growth in patent issuance was reflected in the mass patent assertion campaigns of the second half of the nineteenth century. Thousands of lawsuits were filed annually; the Southern District of New York, for example, saw 381 infringement suits in 1880, which would have ranked it first in 2010 and third in 2014. These lawsuits involved inventions ranging from the aforementioned barbed wire and lightbulb to the process of making vulcanized rubber and a wide array of inventions important to the growing railroad industries. Some of these lawsuits also included features commonly decried today, including participation by non-practicing entities (i.e., entities that own patents but do not manufacture or sell anything) as plaintiffs and end-users as defendants. These enforcement campaigns also engendered grassroots and elite political opposition to the patent system, part of more general anti-monopoly sentiment towards the end of the nineteenth century and the beginning of the twentieth century. *See* Christopher Beauchamp, *The First Patent Litigation Explosion*, 125 YALE L.J. 848 (2016).

In the first half of the twentieth century, patents continued to play the more prominent social and economic roles they attained by the close of the nineteenth century. Epic litigation battles were fought over Selden's automobile patents, the Wright Brothers' airplane patents, and Marconi's radio patents. The trust-busting politics of the Progressive Era led to proposals to sharply limit the strength of patents; in contrast, the Supreme Court largely sided with patentees, at least until the 1940s, when, among other things, it articulated a more stringent nonobviousness requirement in *Cuno Engineering Corp. v. Automatic Devices Corp* and *Great Atlantic & Pacific Tea Co. v. Supermarket Equipment Co.* Individual firms relied on patents to obtain and maintain a competitive edge. For example, Sarah Breedlove—later known as Madam C.J. Walker—became the first Black woman millionaire in the United States selling her patented hair-care products. Entire industries grew on the basis of patented technologies, forcing courts to deal with the tension between the exclusivity of patents and the pro-competition policy of the newly-established federal antitrust regime; the film industry's battles, for example, led to the Supreme Court's landmark patent misuse case, *Motion Picture Patents Co. v. Universal Film Manufacturing Co.*

In the post-World War II era, Congress undertook a wholesale recodification of the patent system, eventually enacting the 1952 Patent Act. Between 1870 and 1952, there had been sixty congressional acts related to patents, including amendments and new enactments. The 1952 Act replaced all these prior statutes with the new Title 35 of the U.S. Code. Title 35 continues to serve as the home for the statutory patent system; post-1952 patent statutes have all been codified there. It's worth taking a minute now to skim

## CHAPTER 1

through the chapter and section headings of Title 35, so you can get a feel for how the patent system is structured.

A core feature of the 1952 Patent Act was its consolidation in Section 102 of novelty and statutory bar doctrines. Novelty refers to an assessment of what was new at the time of the applicant's invention; statutory bar refers to an assessment of what was new at the time of the applicant's filing for a patent. Since its inception and continuing through the 1952 Patent Act, the American patent system was a first-to-invent system. This meant that an individual who was the second to file for a patent on a given invention could nonetheless beat the first-to-file if she could demonstrate that she had invented before the first-to-file had invented. A complex set of rules governed what exactly it meant to invent, and what an inventor had to do in order to retain her priority over subsequent inventors who beat her to the patent office; these rules were also found in Section 102. The statutory bar provisions, meanwhile, forced inventors to submit their applications within a year of specified events (like the first public use of the invention) or lose their rights. As we'll see, through passage of the America Invents Act in 2011, Congress has converted the patent system into a first-to-file system, with a simplified set of rules, though much of the caselaw developed under the first-to-invent system continues to be relevant under the new system.

The 1952 Act also codified the nonobviousness doctrine that had developed in the courts, while rejecting the more stringent versions of that doctrine associated with *Cuno Engineering*. Statutory provisions regarding design patents and plant patents (which had been created in the Plant Patent Act of 1930) were consolidated in Title 35. Judicially-developed infringement rules were largely codified in Section § 271, except for the rules regarding contributory infringement.

The Courts of Appeals then took up the task of elaborating on the 1952 Act's codifications with minimal (though not zero) oversight from the Supreme Court. Those courts were perceived as relatively hostile to patentees, perhaps again as part of their engagement with a burgeoning antitrust regime. This perception, combined with a desire for more doctrinal uniformity in patent law, led Congress to create the Court of Appeals for the Federal Circuit in 1982. The Federal Circuit is now the exclusive venue for appeals from the District Courts "in any civil action arising under, or in any civil action in which a party has asserted a compulsory counterclaim arising under, any Act of Congress relating to patents or plant variety protection." 28 U.S.C. § 1295(a). It also hears appeals from the Patent and Trademark Office, the Court of Federal Claims, and final decisions of the Court of International Trade, among others. This experiment in developing specialized expertise in patent law has drawn significant scholarly attention and a fair deal of criticism. See, e.g., Diane P. Wood, *Keynote Address: Is It Time to Abolish the Federal Circuit's Exclusive Jurisdiction in Patent Cases?*, 13 CHI.-KENT J. INTELL. PROP. 1 (2013);

## INTRODUCTION

Rochelle Cooper Dreyfuss, *The Federal Circuit: A Case Study in Specialized Courts*, 64 N.Y.U. L. REV. 1 (1989).

Developments outside the patent system also influenced the development of the patent system. Two in particular bear mentioning here. First, over the course of the twentieth century, research increasingly took place in formal corporate, academic, and government institutions. This research often produced patentable inventions or at least knowledge and information that could serve as the foundation for developing a patentable invention. In 1980, Congress enacted the Bayh-Dole Act, which made it easier for entities contracting with the federal government, including universities, to retain the patent rights to inventions produced with federal funding. This has transformed the university-industry relationship and the conduct of academic science itself. *See* Rebecca S. Eisenberg, *Proprietary Rights and the Norms of Science in Biotechnology Research*, 97 YALE L.J. 177 (1987). Second, the rise of the software and biotechnology industries has challenged the justification for and structure of the patent system. Software engineers and companies have questioned whether patents help or hurt their industry and have developed alternative models for managing progress in their field. Biotechnology, meanwhile, forces the patent system to confront hard questions of distributive justice, among other doctrinal problems.

There are, of course, additional developments since the 1980s. The Agreement on Trade-Related Aspects of Intellectual Property Treaty (“TRIPS”) was signed in 1994. This has resulted in some changes to US Patent laws to bring them into conformity with other countries. For example, the patent term was changed to be twenty years from the date of filing instead of the previous term of seventeen years from the date of issuance. TRIPS and other international developments have also made it easier for American inventors and entities to file, receive, and enforce patents globally. In addition to these changes, the Supreme Court returned to a more active role in patent doctrine in the 2000s. The 2011 America Invents Act (AIA) made the patent system a first-to-file system and created a series of administrative patent proceedings that streamlined the process for challenging issued patents. Patent law is a dynamic field with wide-ranging implications for technology, science, health, justice, economic growth, the distribution of wealth, and political conflicts. All of this makes practicing (and studying) patent law challenging, worthwhile, and, of course, fun!

## C. Structure of the U.S. Patent System

### 1. Getting a Patent

To obtain a U.S. patent, an inventor must file an application with the U.S. Patent & Trademark Office (USPTO), an agency that is part of the Department of Commerce. After a patent application is filed, it is assigned to an examiner who has a degree (or equivalent experience) in the relevant subject area—for example, someone with a degree in mechanical engineering for mechanical applications or a degree in studio arts for design applications. The examiner will then perform a substantive review of the application. This includes searching for evidence of earlier inventions and other knowledge that might be relevant to the question of whether the invention meets the patentability criteria. These earlier inventions and other knowledge are called “the prior art.”

The examiner’s review of the patent application is guided by the Manual of Patent Examining Procedure (MPEP). The MPEP is a publicly-available document in which USPTO lawyers have summarized various aspects of patent law and practice. Accordingly, the MPEP “reflects the presumptions under which the [USPTO] operates.” *See Critikon, Inc. v. Becton Dickinson Vascular Access, Inc.*, 120 F.3d 1253, 1257 (Fed. Cir. 1997). Therefore, the MPEP is a helpful reference for those who practice (and study) patent law. But the MPEP “does not have the force of law.” *Id.* *See also* Melissa F. Wasserman, *The Changing Guard of Patent Law: Chevron Deference for the PTO*, 54 WM. & MARY L. REV. 1959, 1968 (2013) (“[U]nlike most agencies, the PTO’s legal interpretations of its enabling act—the Patent Act—are afforded no deference, much less strong judicial deference.”).

If the examiner sees a problem with the application, they will issue what is called an “office action.” The applicant must respond to the office action in writing or the application will be deemed abandoned. If the office action contains a non-final rejection, the applicant can attempt to “traverse the rejection”—i.e., overcome the problem—or abandon the application. There may be multiple office actions for a single patent application.

The documents exchanged between the examiner and the applicant are recorded in what is called the application’s “file wrapper” or “prosecution history.” This process of filing and defending a patent application is generally referred to as “patent prosecution.” A recent study found that, on average, a utility patent examiner “spends only eighteen hours reviewing an application,” including “reading the application, searching for prior art, comparing the prior art with the application, writing a rejection, responding to the patent applicant’s arguments, and often conducting an interview with the applicant’s attorney.” Michael D. Frakes & Melissa F. Wasserman, *Irrational Ignorance at the Patent*

## INTRODUCTION

*Office*, 72 VAND. L. REV. 975, 978 (2019). As you learn more about the various utility patent validity doctrines, query whether eighteen hours seems like enough time.

To prosecute a patent for someone else, you have to be registered to practice before the USPTO. Lawyers who are registered to practice before the USPTO are often referred to as being members of “the patent bar.” Only individuals with certain scientific or technical backgrounds are allowed to take the “patent bar” entry exam. This is a relatively recent requirement. *See* William Hubbard, *Razing the Patent Bar*, 59 ARIZ. L. REV. 383, 402, 402 n.104 (2017) (noting “the public record does not disclose when or why the USPTO created the technical-education requirement” but that, as late as 1960, some members of the patent bar did not have technical degrees). *See also* *The Honorable Giles Sutherland Rich Circuit Judge, United State Court of Appeals for the Federal Circuit*, 9 FED. CIR. B.J. 1 (1999) (noting that this famous patent judge had a “degree in history, government, and economics”). The technical background requirement applies to everyone who prosecutes patents—even design patents. For an argument that this requirement does not make sense, *see* Christopher Buccafusco & Jeanne C. Curtis, *The Design Patent Bar: An Occupational Licensing Failure*, 37 CARDOZO ARTS & ENT. L.J. 263 (2019). Note that the technical-background requirement only applies to practice before the USPTO; you don’t have to have a technical background to do other types of patent work, like litigation.

Once issued, a utility patent term typically lasts 20 years from its effective filing date, subject to the payment of maintenance fees. *See* 35 U.S.C. § 154(a)(2); 37 C.F.R. § 1.362. A plant patent also lasts 20 years from its effective filing date but is not subject to maintenance fees. *See* U.S.C. §§ 154(a)(2), 161; 37 C.F.R. § 1.362(b). A design patent lasts for 15 years from its issue date and, like a plant patent, is not subject to maintenance fees. 35 U.S.C. § 173; 37 C.F.R. § 1.362(b).

## 2. Enforcing a Patent

A patent gives its owner various legal rights. This section will provide an overview of how a patent owner can enforce those rights.

### a. Extrajudicial Enforcement

Much—probably most—patent enforcement takes place extrajudicially. A patent owner can contact the person they think is infringing their patent, asking them to cease and desist. In some cases, a demand letter may be enough to get an infringer to stop infringing. When successful, this approach can be quick and inexpensive way to resolve the dispute. But this approach is not without risk to the patent owner. For example, a patent demand letter may trigger declaratory judgment jurisdiction, allowing the accused

## CHAPTER 1

infringer to file a lawsuit in the venue that they—not the patent owner—would prefer. *See SanDisk Corp. v. STMicroelectronics, Inc.*, 480 F.3d 1372, 1380–81 (Fed. Cir. 2007) (“We hold . . . that where a patentee asserts rights under a patent based on certain identified ongoing or planned activity of another party, and where that party contends that it has the right to engage in the accused activity without license, an Article III case or controversy will arise and the party need not risk a suit for infringement by engaging in the identified activity before seeking a declaration of its legal rights.”) (citing *MedImmune, Inc. v. Genentech, Inc.*, 549 U.S. 118, 132 n.11 (2007)).

Also, some states have begun policing patent demand letters. *See Leah Chan Grinvald, Policing the Cease-and-Desist Letter*, 49 U.S.F. L. REV. 411, 418 n.37 (2015) (noting that states have passed “legislation for ‘bad faith assertions of patent infringement’” and that some “state attorneys general actions [have taken action] against certain [parties] for sending abusive letters”). For an example of a state statute that prohibits certain types of patent demand letters, *see Okla. Stat. Ann. tit. 23, § 112(a)*. Why do you think a state would take these kinds of actions? Who do you think is lobbying for (and against) this kind of legislation?

### b. Federal Courts

The federal district courts have exclusive jurisdiction “over any claim for relief arising under any Act of Congress relating to patents, plant variety protection, or copyrights.” 28 U.S.C. § 1338(a). What types of claims might involve patents but not “arise under” the Patent Act? *See Gunn v. Minton*, 568 U.S. 251 (2013).

Today, the Federal Circuit has exclusive appellate jurisdiction “in any civil action arising under, or in any civil action in which a party has asserted a compulsory counterclaim arising under, any Act of Congress relating to patents or plant variety protection.” 28 U.S.C. § 1295(a)(1). Let’s unpack that a bit. Note first that § 1295(a)(1), as opposed to § 1338(a), refers to the “civil action,” not the “claim.” Therefore, the Federal Circuit “has exclusive jurisdiction over all appeals in actions involving patent claims, including where . . . an appeal raises only non-patent issues.” *Oracle Am., Inc. v. Google LLC*, 886 F.3d 1179, 1190 (Fed. Cir. 2018), *rev’d and remanded on other grounds*, 141 S. Ct. 1183 (2021). Why do you think Congress chose to frame the Federal Circuit’s jurisdiction this way? What incentives or opportunities does it create for litigants? Note also that the phrase “any Act of Congress relating to patents” in § 1295 is not limited in any way—it applies to all patents, not just utility patents. The Federal Circuit also has exclusive jurisdiction over appeals from the USPTO’s Patent Trial and Appeal Board (PTAB), 28 U.S.C. § 1295(a)(4)(A), and over final decisions of the United States Court of International Trade (ITC), *id.* § 1295(a)(5), in addition to a number of non-patent appeals.



## INTRODUCTION

The U.S. Court of Appeals for the Federal Circuit has had exclusive jurisdiction over almost all patent appeals since it was created in 1982. In its first decision, the Federal Circuit adopted “the holdings of our predecessor courts, the United States Court of Claims and the United States Court of Customs and Patent Appeals” as “binding as precedent in” the Federal Circuit. *South Corp. v. United States*, 690 F.2d 1368, 1369 (Fed. Cir. 1982). What does (or should) this mean for the precedential status of the old C.C.P.A. cases? For the patent cases decided by the regional circuits prior to 1982?

In recent years, the U.S. Supreme Court has taken an increased interest in patent law. See Paul R. Gugliuzza, *The Supreme Court Bar at the Bar of Patents*, 95 NOTRE DAME L. REV. 1233, 1234 (2020) (“After deciding less than one patent case per Term from 1982 . . . through 2004, the Court has since decided more than forty patent cases—an average of over three per Term.”). As you read through this book, consider what may have prompted the Court’s interest and whether the Court’s increased involvement in patent law is, on the whole, a good thing.

### c. The ITC

Some patent owners can enforce their patents at the ITC. See 19 U.S.C. § 1337(a)(2); *id.* § 1337(3) (stating that this enforcement option is available “only if an industry in the United States, relating to the articles protected by the patent, . . . concerned, exists or is in the process of being established”). As Sapna Kumar explains:

The ITC is an independent agency whose governing statute is the Tariff Act of 1930. Under § 337 of the Tariff Act, the ITC may issue exclusion orders blocking goods that infringe patents . . . from entering the United States; these orders are enforced by the Bureau of Customs and Border Protection in the Department of Homeland Security.

Sapna Kumar, *The Accidental Agency?*, 65 FLA. L. REV. 229, 238–39 (2013). Proceedings at the ITC are termed “investigations,” and are presided over by administrative law judges. Once an administrative law judge has made a determination that Section 337 has been violated, the decision is reviewed by the Commission before becoming final. Appeals from the ITC, like other patent matters, are heard by the Court of Appeals for the Federal Circuit.

In recent years, the ITC has become an increasingly popular venue for patent enforcement. ITC adjudications are generally quicker and less expensive than litigation. See Darrell G. Mottley, *The Tools for Protecting Fashion Law Clients*, ASPATORE, 2012 WL 167353, at \*8 (2012). See also Colleen V. Chien, *Protecting Domestic Industries at the ITC*, 28 SANTA CLARA COMPUTER & HIGH TECH. L.J. 169, 171–72 (2011) (“In an ITC proceeding,

there are no juries, no counterclaims, few stays for reexamination, and no damages. Complaints are likely to be resolved within eighteen months. This level of efficiency makes the ITC one of the world's premier venues for resolving patent disputes.”) (footnotes omitted). Note that a patent owner can bring an enforcement action in both federal district court and in the ITC; they don't have to choose just one forum. *See Colleen V. Chien, Patently Protectionist? An Empirical Analysis of Patent Cases at the International Trade Commission*, 50 WM. & MARY L. REV. 63, 70 (2008) (noting that “65 percent of the ITC cases [she] studied had a district court counterpart”).

The remedies available at the ITC differ from those available in federal district court. In the ITC, damages are not available. There is a form of injunctive relief, however. Upon a finding of infringement, the ITC may issue a limited exclusion order (LEO), associated with specific, infringing goods imported by specified entities. The ITC may also issue a general exclusion order, which prevents any party from importing goods that infringe the patent, as construed by the ITC. These orders are enforced by Customs. For more on the background and remedies available at the ITC, *see Sarah R. Wasserman Rajec, Patents Absent Adversaries*, 81 BROOK. L. REV. 1073, 1075-76 (2016). For a critique that the ITC may appeal to non-practicing entities because of its remedial structure, *see Colleen V. Chien & Mark A. Lemley, Patent Holdup, the ITC, and the Public Interest*, 98 CORNELL L. REV. 1 (2012).

### 3. Challenging a Patent

What if the USPTO makes a mistake and grants a patent that should not have been granted? This section will provide an overview of ways a patent's validity can be challenged. We have already discussed two of the places where patents can be challenged, federal district courts and the ITC. Most parties who are sued for infringement can challenge a patent's validity as a defense or a counterclaim. An accused infringer can also file their own invalidity case against the patent owner pursuant to the Declaratory Judgment Act, 28 U.S.C. § 2201(a). Patent validity can also be raised as a defense in the ITC. But note that, while “[f]ederal court decisions bind the ITC,” the ITC's “determinations of patent issues are not given preclusive effect by federal courts.” Sapna Kumar, *The Other Patent Agency: Congressional Regulation of the ITC*, 61 FLA. L. REV. 529, 559 (2009).

There is another option. Patent validity can be challenged in the USPTO. There have been different mechanisms for obtaining post grant review of issued patents for some time, but recent legislation has increased the availability and use of these post-grant proceedings. In 2011, Congress passed the Leahy-Smith America Invents Act (AIA). The AIA made a number of important changes to U.S. patent law and practice. One of those important changes was the creation of the Patent Trial and Appeal Board (PTAB) and the

## INTRODUCTION

creation of a handful of new administrative proceedings that allow third parties to challenge the validity of issued patents. These proceedings, which “were designed to create a cheaper, faster alternative to district court patent litigation,” have “proven immensely popular.” Christopher J. Walker & Melissa F. Wasserman, *The New World of Agency Adjudication*, 107 CAL. L. REV. 141, 158, 160 (2019). The current system combines a blend of old and new proceedings; while the ex parte reexamination procedures that were introduced in 1980 remain available, the inter partes reexamination procedures added in 1999 have been replaced by the AIA’s mechanisms. We will discuss these proceedings in more detail in Chapter 13.

### D. The Patent Document

The anatomy of an issued patent varies depending on the type of patent. But all of the different types have a cover page and information about the invention. They also include a description of the invention, or “specification.” The specification includes one or more claims. Those claims form the basis for the scope of the patentee’s legal rights. The information required in the specification, as well as the form and number of claims varies depending on the type of patent at issue. Utility patents can (and usually do) have more than one claim; design and plant patents can have only one claim. The cover page of a patent provides a wide range of information, including the patent number, the date the patent was issued, the filing date, the title of the patent, the name of the human inventor (or inventors), and the assignee at issue (if any). You can tell what kind of patent something is just by looking at the header on the cover page. A utility patent has “United States Patent” written in the top left corner and includes a patent number that is just a plain number, as can be seen in U.S. Patent No. 8,371,044, entitled “Shoes”:

(12) <b>United States Patent</b> <b>Rusnak</b>	(10) <b>Patent No.:</b> <b>US 8,371,044 B2</b>
	(45) <b>Date of Patent:</b> <b>Feb. 12, 2013</b>
(54) <b>SHOES</b>	D261,195 S 10/1981 Weiss D282,309 S 1/1986 Valori D282,310 S 1/1986 Valori (Continued)
(75) Inventor: <b>Joel Rusnak</b> , Newburyport, MA (US)	
(73) Assignee: <b>Poliwalks, Inc.</b> , Sudbury, MA (US)	FOREIGN PATENT DOCUMENTS
(*) Notice: Subject to any disclaimer, the term of this patent is extended or adjusted under 35 U.S.C. 154(b) by 566 days.	CN 2618470 Y 6/2004 CN 2724453 Y 9/2005 (Continued)
(21) Appl. No.: <b>12/505,893</b>	OTHER PUBLICATIONS
(22) Filed: <b>Jul. 20, 2009</b>	Online webpage, Crocs Footwear, Crocs, Inc. (Niwot, Colorado); Downloaded Aug. 1, 2007, <a href="http://shop.crocs.com/c-4-Footwear.aspx?reqid=4&amp;reqProdTypeId=4&amp;subsectionname=footwear">http://shop.crocs.com/c-4-Footwear.aspx?reqid=4&amp;reqProdTypeId=4&amp;subsectionname=footwear</a> .
(65) <b>Prior Publication Data</b> US 2010/0126045 A1 May 27, 2010	<i>Primary Examiner</i> — Marie Patterson (74) <i>Attorney, Agent, or Firm</i> — Antoinette G. Giugliano; AGG Intellectual Property Law

CHAPTER 1

A design patent has “United States Design Patent” written on it and includes a patent number that starts with “D,” as can be seen in U.S. Patent No. D674,993, which claims a design for a “Dress”:

(12) <b>United States Design Patent</b> <b>Howie</b>	(10) <b>Patent No.:</b> <b>US D674,993 S</b> (45) <b>Date of Patent:</b> <b>** Jan. 29, 2013</b>
(54) <b>DRESS</b>	Next2Nowt.com. <a href="http://next2nowt.com/velvet-polka-dot-feel-mesh-panel-dress-various">http://next2nowt.com/velvet-polka-dot-feel-mesh-panel-dress-various</a> . Copyright 2012. “Velvet Feel Polka Dot Mesh Panel Dress”.*
(75) Inventor: <b>Frances Howie</b> , London (GB)	Saks Fifth Avenue. <a href="http://www.saksfifthavenue.com/main/ProductDetail.jsp?FOLDER&lt;folder_id=2534374306418059&amp;PRODUCT&lt;prd_id=845524446452210&amp;site_refer=AFF001&amp;mid=13816&amp;siteID=J84DHJLQkR4-fyQ.orLYSeBGKR9Rb8hlRw&amp;LScreativeid=1&amp;LSlinkid=15&amp;LSoid=203720&amp;LSsid=J84DHJLQkR4">http://www.saksfifthavenue.com/main/ProductDetail.jsp?FOLDER&lt;folder_id=2534374306418059&amp;PRODUCT&lt;prd_id=845524446452210&amp;site_refer=AFF001&amp;mid=13816&amp;siteID=J84DHJLQkR4-fyQ.orLYSeBGKR9Rb8hlRw&amp;LScreativeid=1&amp;LSlinkid=15&amp;LSoid=203720&amp;LSsid=J84DHJLQkR4</a> . Copyright 2012. “ABS Polka Dot Dress”.*
(73) Assignee: <b>Stella McCartney Limited</b> , London (GB)	ASOS. <a href="http://us.asos.com/Motel/Motel-Dress-in-Hexagon-Mesh/Prod/pgeproduct.aspx?iid=2299967&amp;cid=8799&amp;sh=0&amp;pge=0&amp;pgesize=20&amp;sort=-1&amp;clr=Periwinkle">http://us.asos.com/Motel/Motel-Dress-in-Hexagon-Mesh/Prod/pgeproduct.aspx?iid=2299967&amp;cid=8799&amp;sh=0&amp;pge=0&amp;pgesize=20&amp;sort=-1&amp;clr=Periwinkle</a> . Copyright 2012. “Motel Dress in Hexagon Mesh”.*
(**) Term: <b>14 Years</b>	
(21) Appl. No.: <b>29/395,029</b>	
(22) Filed: <b>Nov. 10, 2011</b>	

A plant patent has “United States Plant Patent” written at the top, and includes a patent number that starts with “PP,” as can be seen in U.S. Patent No. PP30,683, which claims a “*Phalaenopsis* Orchid Plant Named ‘Butterfly Kisses.’”

(12) <b>United States Plant Patent</b> <b>Schoone</b>	(10) <b>Patent No.:</b> <b>US PP30,683 P3</b> (45) <b>Date of Patent:</b> <b>Jul. 9, 2019</b>
(54) <b>PHALAEOPSIS ORCHID PLANT NAMED ‘BUTTERFLY KISSES’</b>	(30) <b>Foreign Application Priority Data</b> Sep. 29, 2016 (NL) ..... PBR OPS1384
(50) Latin Name: <i>Phalaenopsis hybrida</i> Varietal Denomination: <b>Butterfly Kisses</b>	(51) <b>Int. Cl.</b> <b>A01H 5/02</b> (2018.01)
(71) Applicant: <b>Floricultura</b> , Heemskerk (NL)	(52) <b>U.S. Cl.</b> USPC ..... <b>Plt./311</b> CPC ..... <b>A01H 5/02</b> (2013.01)
(72) Inventor: <b>René Schoone</b> , Assendelft (NL)	(58) <b>Field of Classification Search</b> USPC ..... Plt./263.1, 311 See application file for complete search history.
(73) Assignee: <b>FLORICULTURA</b> , Heemskerk (NL)	<i>Primary Examiner</i> — Susan McCormick Ewoldt <i>Assistant Examiner</i> — Karen M Redden
(*) Notice: Subject to any disclaimer, the term of this patent is extended or adjusted under 35 U.S.C. 154(b) by 0 days.	(74) <i>Attorney, Agent, or Firm</i> — Sunit Talapatra; Foley & Lardner LLP
(21) Appl. No.: <b>15/732,149</b>	

All design patents and many utility patents also include a representative drawing on the cover page. Here is the entire cover page of U.S. Patent No. 10,813,363, a utility patent entitled “Portable Cinnamon Roll and Method for Making” (“the ‘363 patent”):

# INTRODUCTION



(12) **United States Patent**  
**Kwitek**

(10) **Patent No.:** US 10,813,363 B2  
(45) **Date of Patent:** Oct. 27, 2020

(54) **PORTABLE CINNAMON ROLL AND METHOD FOR MAKING**

(71) Applicant: **GELLYFISH TECHNOLOGY OF TEXAS, LLC**, Marshall, TX (US)

(72) Inventor: **Benjamin J Kwitek**, Canon City, CO (US)

(\* ) Notice: Subject to any disclaimer, the term of this patent is extended or adjusted under 35 U.S.C. 154(b) by 0 days.

(21) Appl. No.: **15/176,793**

(22) Filed: **Jun. 8, 2016**

(65) **Prior Publication Data**  
US 2016/0353753 A1 Dec. 8, 2016

**Related U.S. Application Data**  
(60) Continuation of application No. 13/251,758, filed on Oct. 3, 2011, now abandoned, which is a division of application No. 11/249,666, filed on Oct. 14, 2005, now Pat. No. 7,608,790.  
(60) Provisional application No. 60/618,133, filed on Oct. 14, 2004.

(51) **Int. Cl.**  
*A21D 13/31* (2017.01)  
*A21D 15/02* (2006.01)

(52) **U.S. Cl.**  
CPC ..... *A21D 13/31* (2017.01); *A21D 15/02* (2013.01)

(58) **Field of Classification Search**  
None  
See application file for complete search history.

(56) **References Cited**  
U.S. PATENT DOCUMENTS

4,882,185 A 11/1989 Simelunas et al.  
5,433,447 A 7/1995 Pocklington

5,514,395 A 5/1996 Burger  
5,654,021 A 8/1997 Burger  
6,054,698 A 4/2000 Mast  
6,280,782 B1 8/2001 Hahn et al.  
6,589,583 B1 7/2003 Hansen et al.  
6,616,960 B2 9/2003 Peterson et al.  
2002/0068115 A1 6/2002 Hayes-Jacobson  
2003/0165605 A1 9/2003 Brown et al.  
2004/0096548 A1 5/2004 Stevens et al.

**FOREIGN PATENT DOCUMENTS**

EP 0547551 A1 6/1993

**OTHER PUBLICATIONS**

"Lemon-Poppy Seed Doughnut Holes". Available online from myrecipes.com from Sunset, as of May 2003, pp. 1-2.  
Definition of "doughnut". Retrieved online from thefreedictionary.com Jan. 31, 2013, p. 1.  
Parrish. "The pan where East meets West". Available online Aug. 2, 2001 from old.post-gazette.com, pp. 1-3.  
Joy of Baking.com. "Frosting or Icing". Available online Aug. 1, 2003, pp. 1-3.  
Diana's Desserts—Danish Aebleskiver. Available online Aug. 23, 2003 from www.dianasdesserts.com, pp. 1-3.  
"Ball Diameter". Available online Mar. 6, 2003 from leaderboard.com, p. 1.

*Primary Examiner* — Jenna A Watts

(74) *Attorney, Agent, or Firm* — Law Office of Scott C Harris, Inc

(57) **ABSTRACT**

A method for manufacturing a portable cinnamon roll includes forming raw dough in the shape of a sphere having a central pocket, placing cinnamon, frosting and sugar within the central pocket and cooking the raw dough with cinnamon, frosting and sugar until it is fully prepared for consumption.

**5 Claims, 3 Drawing Sheets**

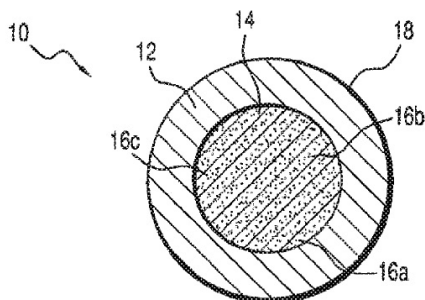

The most important part of the patent document is the claim(s). We'll learn more about plant and design patent claims in Chapters 11 and 12. For now, let's focus on utility patent claims. In a utility patent, the claims are located at the end of the specification and they are numbered. The USPTO requires utility patent claims to be written in a single sentence. Sometimes those sentences are pretty long.

For example, Claim 1 of the '363 patent reads as follows:

The invention claimed is:

1. A portable cinnamon roll, comprising:

a section of dough, formed into a generally spherical shape, having an outer surface and a central pocket inside the outer surface and not exposed to the outer surface,

said outer surface being of approximately 0.5 inches to approximately 2.5 inches in diameter,

the central pocket including a different material than the outer surface,

wherein the central pocket is isolated from the outer surface of the portable cinnamon roll, the central pocket having an encapsulated portion inside said central pocket with said different material therein, said different material formed of cinnamon, frosting and sugar, wherein the outer surface does not have said cinnamon, frosting and sugar.

As you can see, this claim includes a preamble (“a portable cinnamon roll”), a transition phrase (“comprising”), and then a number of other phrases (the “limitations”).

This claim uses the transition “comprising.” According to the USPTO, “[t]he transitional term ‘comprising’ . . . is inclusive or open-ended and does not exclude additional, unrecited elements or method steps.” MPEP § 2111.03(I). So if a utility patent claimed an invention “comprising A, B, and C,” that claim would be infringed by a product with elements A, B, C, and D. But it would not be infringed by a product with only A, C, and D.

There are other transition phrases. For example, “[t]he transitional phrase ‘consisting of’ excludes any element, step, or ingredient not specified in the claim.” MPEP § 2111.03(II). So if a utility patent claimed an invention “consisting of A, B, and C,” it would not be infringed by a product that with elements A, B, C, and D. There are some nuances. *See id.* (discussing different rules for “[w]hen the phrase ‘consists of’ appears in a clause of the body of a claim, rather than immediately following the preamble” and for what are called “*Markush* claims”).

One other transitional phrase you may see is “consisting essentially of.” This phrase “limits the scope of a claim to the specified materials or steps and those that do not materially affect the basic and novel characteristics of the claimed invention.” *Id.* § 2111.03(III) (internal quotation marks omitted). “A ‘consisting essentially of’ claim occupies a middle ground between closed claims that are written in a ‘consisting of’ format and fully open claims that are drafted in a ‘comprising’ format.” *Id.*

## 2. THE INVENTION, THE PATENT, AND THE CLAIM

Patent law is about inventions. The Constitution grants Congress the power to “promote the Progress of . . . useful Arts, by securing for limited Times to . . . Inventors the exclusive Right to their . . . Discoveries.” U.S. Const., art. I, § 1, cl. 8. The patent statute defines “invention” as an “invention or discovery,” 35 U.S.C. § 100(a), and provides that “[w]hoever invents or discovers any new and useful process, machine, manufacture, or composition of matter, or any new and useful improvement thereof, may obtain a patent therefor.” 35 U.S.C. § 101; *see also* 35 U.S.C. § 161 (authorizing, with some exceptions, the issuance of patents to “[w]hoever invents or discovers and asexually reproduces any distinct and new variety of plant”); 35 U.S.C. § 171 (authorizing the issuance of patents to “[w]hoever invents any new, original and ornamental design for an article of manufacture”). But what exactly is an invention? Who is an inventor? What does it mean to invent something? These questions arise repeatedly across patent doctrines.

What pops into your head when you read the word “invention”? That word has some connotation of novelty or advanced technology, so maybe you think of a new medicine or a humanoid robot or an electric car or a smartphone. But every commonplace object in our lives was new at some point in the past. Bicycles, steam engines, and paper clips were all once cutting-edge technology (and the subject of fascinating patents!), even if we are not likely to think of them as inventions today.

In this Chapter, we will explore the relationship between the invention, the patent, and the claim. To simplify the discussion, our focus here is on utility patents (design and plant patents raise distinct issues with respect to the relationship between the invention, the patent, and the claim, and you may wish to revisit some of the questions raised here later). A first rough cut might go something like this: An invention is something new that a person has produced by thinking and experimenting and working with what already exists; it’s the thing in the world that the inventor has made. The patent then describes that thing and the claims set limits on the inventor’s exclusive rights to it.

This rough cut is imperfect—nothing in it distinguishes an invention from other kinds of products of human intellect. It’s also worth noting that the Constitution speaks of rights to “Discoveries” and that the statutory language treats inventions and discoveries as equivalent. As you read this chapter, consider how we might make the definition of “invention” more precise. Many problems in patent law arise because it is not exactly clear what society is prepared to recognize as inventions. As we’ll see later, the invention might also be something intangible, like the steps in a process; in other instances, the information

a person discloses in the patent might itself be the invention. In addition, the description in the patent specification might not adequately characterize the things the inventor did in the world, raising concerns that the patentee has not held up her end of the patent bargain. Finally, the claims themselves may not map precisely to the things the inventor did or the things the patentee hoped to cover.

These issues are perhaps most salient when we consider patent scope—the question of how narrowly or broadly does a patent reach. Scope is explicitly at issue in claim construction, the process of giving legal effect to the words of the claim. But scope is also implicit in many doctrines in the patent system, including patent eligibility, enablement, and infringement. *See* Mark A. Lemley & Mark P. McKenna, *Scope*, 57 WM. & MARY L. REV. 2197 (2016). Most of the cases in this chapter were principally presented to the courts as claim construction cases, but you will also read analyses that sound more in enablement or infringement than in claim construction. This is partly attributable to the state of the doctrine at the time the cases were decided; courts in the 1800s did not so neatly draw lines between patent law doctrines as they (attempt to) do today. But it is also a result of the fact that these doctrines are to some extent necessarily intertwined.

We'll begin our exploration of the invention, the patent, and the claim with the lightbulb. The lightbulb is an iconic invention. You may right now be picturing a lightbulb appearing above an inventor's head as she shouts "Eureka!" You also probably have an idea of who invented the lightbulb. As you read the landmark case that follows, consider what the Court's discussion implies for your idea of what it meant to "invent" the "lightbulb" and who deserved the label "inventor" as a result.

*Consolidated Electric Light Co. v. McKeesport Light Co.*  
(The Incandescent Lamp Patent Case)  
159 U.S. 465 (1895)

This was a bill in equity, filed by the Consolidated Electric Light Company against the McKeesport Light Company, to recover damages for the infringement of letters patent No. [317,676], issued May 12, 1885, to the Electro-Dynamic Light Company, assignee of Sawyer and Man, for an electric light. The defendants justified under certain patents to Thomas A. Edison, particularly No. 223,898, issued January 27, 1880; denied the novelty and utility of the complainant's patent; and averred that the same had been fraudulently and illegally procured. The real defendant was the Edison Electric Light Company, and the case involved a contest between what are known as the Sawyer and Man and the Edison systems of electric lighting.

In their application, Sawyer and Man stated that their invention related to "that class of electric lamps employing an incandescent conductor inclosed in a transparent,



## THE INVENTION, THE PATENT, AND THE CLAIM

hermetically sealed vessel or chamber, from which oxygen is excluded, and . . . more especially to the incandescing conductor, its substance, its form, and its combination with the other elements composing the lamp. Its object is to secure a cheap and effective apparatus; and our improvement consists, first, of the combination, in a lamp chamber, composed wholly of glass, as described in patent No. 205,144," upon which this patent was declared to be an improvement, "of an incandescing conductor of carbon made from a vegetable fibrous material, in contradistinction to a similar conductor made from mineral or gas carbon, and also in the form of such conductor so made from such vegetable carbon, and combined in the lighting circuit with the exhausted chamber of the lamp."

The following drawings exhibit the substance of the invention:

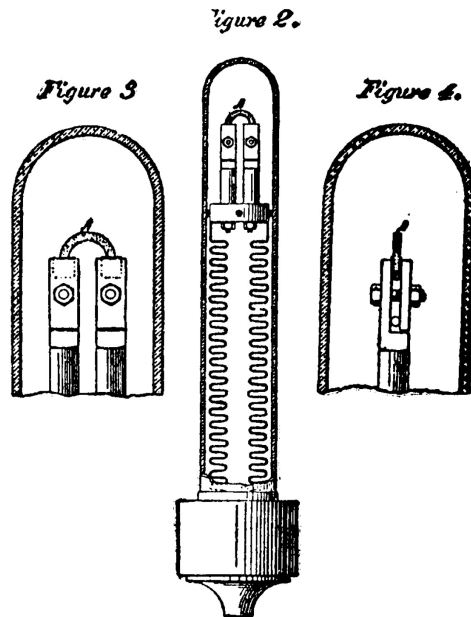

The specification further stated that:

In the practice of our invention, we have made use of carbonized paper, and also wood carbon. We have also used such conductors or burners of various shapes, such as pieces with their lower ends secured to their respective supports, and having their upper ends united so as to form an inverted V-shaped burner. We have also used conductors of varying contours,—that is, with rectangular bends instead of curvilinear ones; but we prefer the arch shape.

No especial description of making the illuminating carbon conductors, described in this specification, and making the subject-matter of this improvement, is

## CHAPTER 2

thought necessary, as any of the ordinary methods of forming the material to be carbonized to the desired shape and size, and carbonizing it while confined in retorts in powdered carbon, substantially according to the methods in practice before the date of this improvement, may be adopted in the practice thereof by any one skilled in the arts appertaining to the making of carbons for electric lighting or for other use in the arts.

An important practical advantage which is secured by the arch form of incandescing carbon is that it permits the carbon to expand and contract under the varying temperatures to which it is subjected when the electric current is turned on or off without altering the position of its fixed terminals. Thus, the necessity for a special mechanical device to compensate for the expansion and contraction which has heretofore been necessary is entirely dispensed with, and thus the lamp is materially simplified in its construction. Another advantage of the arch form is that the shadow cast by such burners is less than that produced by other forms of burners when fitted with the necessary devices to support them.

...

The advantages resulting from the manufacture of the carbon from vegetable fibrous or textile material instead of mineral or gas carbon are many. Among them may be mentioned the convenience afforded for cutting and making the conductor in the desired form and size, the purity and equality of the carbon obtained, its susceptibility to tempering, both as to hardness and resistance, and its toughness and durability. . . .

The claims were as follows:

- (1) An incandescing conductor for an electric lamp, of carbonized fibrous or textile material, and of an arch or horseshoe shape, substantially as hereinbefore set forth.
- (2) The combination, substantially as hereinbefore set forth, of an electric circuit and an incandescing conductor of carbonized fibrous material, included in and forming part of said circuit, and a transparent, hermetically sealed chamber, in which the conductor is inclosed.
- (3) The incandescing conductor for an electric lamp, formed of carbonized paper, substantially as described.
- (4) An incandescing electric lamp consists of the following elements in combination: First, an illuminating chamber made wholly of glass hermetically sealed, and out of which all carbon-consuming gas has been exhausted or driven; second, an electric-circuit conductor passing through the glass wall of said chamber, and hermetically sealed therein, as described; third, an illuminating

## THE INVENTION, THE PATENT, AND THE CLAIM

conductor in said circuit, and forming part thereof within said chamber, consisting of carbon made from a fibrous or textile material, having the form of an arch or loop, substantially as described, for the purpose specified.

...

[T]he court held the patent to be invalid, and dismissed the bill. Thereupon complainant appealed to this court.

Mr. Justice BROWN . . . delivered the opinion of the court.

In order to obtain a complete understanding of the scope of the Sawyer and Man patent, it is desirable to consider briefly the state of the art at the time the application was originally made, which was in January, 1880.

Two general forms of electric illumination had for many years been the subject of experiments more or less successful, one of which was known as the "arc light," produced by the passage of a current of electricity between the points of two carbon pencils placed end to end, and slightly separated from each other. In its passage from one point to the other through the air, the electric current took the form of an arc, and gave the name to the light. This form of light had been produced by Sir Humphry Davy as early as 1810, and, by successive improvements in the carbon pencils and in their relative adjustment to each other, had come into general use as a means of lighting streets, halls, and other large spaces; but by reason of its intensity, the uncertain and flickering character of the light, and the rapid consumption of the carbon pencils, it was wholly unfitted for domestic use. The second form of illumination is what is known as the "incandescent system," and consists generally in the passage of a current of electricity through a continuous strip or piece of refractory material, which is a conductor of electricity, but a poor conductor; in other words, a conductor offering a considerable resistance to the flow of the current through it. It was discovered early in this century that various substances might be heated to a white heat by passing a sufficiently strong current of electricity through them. . . .

For many years prior to 1880, experiments had been made by a large number of persons, in various countries, with a view to the production of an incandescent light which could be made available for domestic purposes, and could compete with gas in the matter of expense. Owing part[l]y to a failure to find a proper material, which should burn but not consume, partly to the difficulty of obtaining a perfect vacuum in the globe in which the light was suspended, and partly to a misapprehension of the true principle of incandescent lighting, these experiments had not been attended with success; although it had been demonstrated as early as 1845 that, whatever material was used, the conductor must be inclosed in an a[ir]-tight bulb, to prevent it from being consumed by the oxygen in the atmosphere. The chief difficulty was that the carbon burners were subject to a rapid disintegration or evaporation, which electricians assumed was due to the disrupting

## CHAPTER 2

action of the electric current, and hence the conclusion was reached that carbon contained in itself the elements of its own destruction, and was not a suitable material for the burner of an incandescent lamp.

It is admitted that the lamp described in the Sawyer and Man patent is no longer in use, and was never a commercial success; that it does not embody the principle of high resistance with a small illuminating surface; that it does not have the filament burner of the modern incandescent lamp; that the lamp chamber is defective; and that the lamp manufactured by the complainant, and put upon the market, is substantially the Edison lamp; but it is said that, in the conductor used by Edison (a particular part of the stem of the bamboo, lying directly beneath the siliceous cuticle, the peculiar fitness for which purpose was undoubtedly discovered by him), he made use of a fibrous or textile material covered by the patent to Sawyer and Man, and is therefore an infringer. It was admitted, however, that the third claim—for a conductor of carbonized paper—was not infringed.

The two main defenses to this patent are (1) that it is defective upon its face, in attempting to monopolize the use of all fibrous and textile materials for the purpose of electric illuminations; and (2) that Sawyer and Man were not in fact the first to discover that these were better adapted than mineral carbons to such purposes.

Is the complainant entitled to a monopoly of all fibrous and textile materials for incandescent conductors? If the patentees had discovered in fibrous and textile substances a quality common to them all, or to them generally, as distinguishing them from other materials, such as minerals, etc., and such quality or characteristic adapted them peculiarly to incandescent conductors, such claim might not be too broad. If, for instance, minerals or porcelains had always been used for a particular purpose, and a person should take out a patent for a similar article of wood, and woods generally were adapted to that purpose, the claim might not be too broad, though defendant used wood of a different kind from that of the patentee. But if woods generally were not adapted to the purpose, and yet the patentee had discovered a wood possessing certain qualities, which gave it a peculiar fitness for such purpose, it would not constitute an infringement for another to discover and use a different kind of wood, which was found to contain similar or superior qualities. The present case is an apt illustration of this principle. Sawyer and Man supposed they had discovered in carbonized paper the best material for an incandescent conductor. Instead of confining themselves to carbonized paper, as they might properly have done, and in fact did in their third claim, they made a broad claim for every fibrous or textile material, when in fact an examination of over 6,000 vegetable growths showed that none of them possessed the peculiar qualities that fitted them for that purpose. Was everybody, then, precluded by this broad claim from making further investigation? We think not.

## THE INVENTION, THE PATENT, AND THE CLAIM

The injustice of so holding is manifest in view of the experiments made, and continued for several months, by Mr. Edison and his assistants, among the different species of vegetable growth, for the purpose of ascertaining the one best adapted to an incandescent conductor. Of these he found suitable for his purpose only about three species of bamboo, one species of cane from the valley of the Amazon (impossible to be procured in quantities on account of the climate), and one or two species of fibers from the agave family. Of the special bamboo, the walls of which have a thickness of about  $\frac{3}{8}$  of an inch, he used only about  $\frac{20}{1000}$  of an inch in thickness. In this portion of the bamboo the fibers are more nearly parallel, the cell walls are apparently smallest, and the pithy matter between the fibers is at its minimum. . . . But finally, while experimenting with a bamboo strip which formed the edge of a palm-leaf fan, cut into filaments, [Edison] obtained surprising results. After microscopic examination of the material, he dispatched a man to Japan to make arrangements for securing the bamboo in quantities. It seems that the characteristic of the bamboo which makes it particularly suitable is that the fibers run more nearly parallel than in other species of wood. . . . There is no generic quality, however, in vegetable fibers, because they are fibrous, which adapts them to the purpose. Indeed, the fibers are rather a disadvantage. . . . No exogenous, and very few endogenous, growths are suitable. The messenger whom he dispatched to different parts of Japan and China sent him about 40 different kinds of bamboo . . . . From this it appears very clearly that there is no such quality common to fibrous and textile substances generally as makes them suitable for an incandescent conductor, and that the bamboo which was finally pitched upon, and is now generally used, was not selected because it was of vegetable growth, but because it contained certain peculiarities in its fibrous structure which distinguished it from every other fibrous substance. The question really is whether the imperfectly successful experiments of Sawyer and Man, with carbonized paper and wood carbon, conceding all that is claimed for them, authorize them to put under tribute the results of the brilliant discoveries made by others.

It is required by Rev. St. § 4888, that the application shall contain "a written description of the device, and of the manner and process of making[,] constructing, compounding, and using it in such full, clear, concise, and exact terms as to enable any person, skilled in the art or science to which it appertains or with which it is most nearly connected, to make, construct, compound, and use the same." The object of this is to apprise the public of what the patentee claims as his own, the courts of what they are called upon to construe, and competing manufacturers and dealers of exactly what they are bound to avoid. If the description be so vague and uncertain that no one can tell, except by independent experiments, how to construct the patented device, the patent is void.

...

Applying this principle to the patent under consideration, how would it be possible for a person to know what fibrous or textile material was adapted to the purpose of an incandescent conductor, except by the most careful and painstaking experimentation? If, as before observed, there were some general quality, running through the whole fibrous and textile kingdom, which distinguished it from every other, and gave it a peculiar fitness for the particular purpose, the man who discovered such quality might justly be entitled to a patent; but that is not the case here. . . . Under these circumstances, to hold that one who had discovered that a certain fibrous or textile material answered the required purpose should obtain the right to exclude everybody from the whole domain of fibrous and textile materials, and thereby shut out any further efforts to discover a better specimen of that class than the patentee had employed, would be an unwarranted extension of his monopoly, and operate rather to discourage than to promote invention. If Sawyer and Man had discovered that a certain carbonized paper would answer the purpose, their claim to all carbonized paper would, perhaps, not be extravagant; but the fact that paper happens to belong to the fibrous kingdom did not invest them with sovereignty over this entire kingdom, and thereby practically limit other experimenters to the domain of minerals.

In fact, such a construction of this patent as would exclude competitors from making use of any fibrous or textile material would probably defeat itself, since, if the patent were infringed by the use of any such material, it would be anticipated by proof of the prior use of any such material. In this connection it would appear, not only that wood charcoal had been constantly used since the days of Sir Humphry Davy for arc lighting, but that in the English patent to Greener and Staite, of 1846, for an incandescent light, "charcoal, reduced to a state of powder," was one of the materials employed. So also, in the English patent of 1841 to De Moleyns, "a finely pulverized boxwood charcoal or plumbago" was used for an incandescent electric lamp. Indeed, in the experiments of Sir Humphry Davy, early in the century, pieces of well-burned charcoal were heated to a vivid whiteness by the electric current, and other experiments were made which evidently contemplated the use of charcoal heated to the point of incandescence. . . . There is undoubtedly a good deal of testimony tending to show that, for the past 50 or 60 years, the word "charcoal" has been used in the art, not only to designate carbonized wood, but mineral or hard carbons, such as were commonly employed for the carbon pencils of arc lamps. But we think it quite evident that, in the patents and experiments above referred to, it was used in its ordinary sense of charcoal obtained from wood. The very fact of the use of such word to designate mineral carbons indicates that such carbons were believed to possess peculiar properties required for illumination, that before that had been supposed to belong to wood charcoal.

. . . [W]e are all agreed that the claims of this patent, with the exception of the third, are too indefinite to be the subject of a valid monopoly. . . .

## Context & Application

1. So: Who invented the lightbulb? Relatedly: What is the lightbulb?

2. How did Sawyer and Man understand their own contribution to the development of the lightbulb? To what extent do you think the specification and the claims reflected that understanding? Were Sawyer and Man deliberately trying to capture more than they deserved? What else might explain any dissonance between their understanding of the invention, as reflected in the specification, and the reach of their claims?

3. How did the Court understand Sawyer and Man's contribution to the development of the lightbulb? To what extent does it coincide or diverge from Sawyer and Man's understanding? How much weight did the Court place on the specification to establish the patent's scope? How much weight on the words of the claims? How much weight on the Court's assessment of the state of the art before Sawyer and Man? From where does the Court derive its assessment?

4. The procedural posture of the case is a bit complicated. Consolidated Electric Light Company sued McKeesport Light Company for infringing Patent No. 317,676. Consolidated Electric had acquired the patent from Electro-Dynamic Light Company, which had earlier acquired it from the inventors, Sawyer and Man. McKeesport raised several defenses. One of them relied on patents that had issued to Edison. But Edison's patents could not excuse McKeesport from infringement of Consolidated Electric's patent. In other words, even if McKeesport had the right to use inventions covered by patents issued to Edison, it might still be liable for infringing Consolidated Electric's patents.

Patent law permits an inventor to obtain a patent on a nonobvious improvement to an existing patent. This can lead to what is known as a "blocking patent" situation. See Robert Merges, *Intellectual Property Rights and Bargaining Breakdown: The Case of Blocking Patents*, 62 TENN. L. REV. 75 (1994). In such a situation neither the subsequent inventor nor the owner of the rights to the earlier patent can use the improvement without the permission of the other. Edison was relevant, however, insofar as his experiments informed the Court's assessment of whether the Sawyer and Man patents satisfied the enablement requirement. As we'll see later, a robust set of rules have developed to determine whether the information disclosed in the specification is sufficient. Here, note that Edison's work appears principally to shed light on the question of whether Sawyer and Man's patents met this requirement, not because any patents Edison obtained could have excused McKeesport's infringement. If McKeesport were to have avoided liability, it would have been because Sawyer and Man's patent was invalid or because McKeesport did not engage in the conduct covered by the patent.

5. Suppose Sawyer and Man had understood that high resistance was key to making the lightbulb work but had not found any materials with sufficiently high resistance to make the lightbulb commercially viable. Would the outcome in the case have changed? How would you have advised them if they sought your assistance in applying for a patent?

6. Edison was a sophisticated actor in the patent system; his lab regularly used patents to learn about what others had done and its work resulted in over a thousand patents. But he did not rely on patent exclusivity alone to appropriate the value of the inventions he worked on. The opinion notes that “[a]fter microscopic examination of the material, [Edison] dispatched a man to Japan to make arrangements for securing the bamboo in quantities.” How do you suppose he might have secured large quantities of bamboo? What are the implications for a competitive market in lightbulbs? What does this suggest about the private efficacy and social desirability of patents as compared to non-patent mechanisms for appropriating the social value of an invention? See Jonathan M. Barnett, *Private Protection of Patentable Goods*, 25 CARDOZO L. REV. 1251 (2003) (describing non-patent tools available to private actors to appropriate the value of their inventions); Daniel J. Hemel & Lisa Larrimore Ouellette, *Innovation Policy Pluralism*, 128 YALE L.J. 544 (2019) (situating patents within a larger toolkit of government policies for encouraging investment in innovation).

7. For an introduction to the large literature exploring the relationship between the invention, the patent, and the claim, see Jeanne C. Fromer & Mark P. McKenna, *Claiming Design*, 167 U. PENN. L. REV. 123 (2018) (contrasting the patent, copyright, and trademark approaches to claiming designs); Christopher A. Cotropia, *What Is the “Invention”?*, 53 WM. & MARY L. REV. 1855 (2012) (distinguishing between an “external invention” approach that focuses on the specification and a “claim-centered invention” approach that focuses “almost exclusively on the claim”); Oskar Liivak, *Rescuing the Invention from the Cult of the Claim*, 42 SETON HALL L. REV. 1 (2012) (critiquing the modern patent system’s emphasis on the claim and arguing for that a better approach would recognize the invention as a “substantive, technical concept” grounded in the statutory language); Dan L. Burk & Mark A. Lemley, *Fence Posts or Sign Posts: Rethinking Patent Claim Construction*, 157 U. PENN. L. REV. 1743 (2009) (arguing that the patent system ought to return to some of the central claiming principles that prevailed until the 1870s); Jeanne Fromer, *Claiming Intellectual Property*, 76 U. CHI. L. REV. 719 (2009) (comparing the patent and copyright system’s approaches to claiming rights to their respective subject matters).





## THE INVENTION, THE PATENT, AND THE CLAIM

While the core legal question in *The Incandescent Lamp Patent Case* was whether the patent was valid, the core legal question in the cases that follow is whether the patent is infringed. Still, the problem of patent scope—and the underlying relationship between the invention, the patent, and the claim—remains at the heart of the analysis. As you read these cases, think back to what you learned from *The Incandescent Lamp Patent Case* about the history of the development of the lightbulb and the way that history influenced the Court’s resolution of the dispute. With that in mind, consider what the inventors in each case might have contributed to the art, and how the court’s understanding of that contribution influences (or doesn’t influence) its analysis.

### *Winans v. Denmead* 56 U.S. 330 (1853)

Mr. Justice CURTIS delivered the opinion of the Court.

This is a writ of error to the Circuit Court of the United States, for the District of Maryland. The plaintiff in error brought his action in that court for an infringement of the exclusive right to make, use, and sell “an improvement in cars for the transportation of coal,” &c., granted to him by letters-patent, bearing date on the 26th day of June, 1847; and, the judgment of that court being for the defendants, he has brought the record here by this writ of error.

...

On such a trial, two questions arise. The first is, what is the thing patented; the second, has that thing been constructed, used, or sold by the defendants.

...

In this, as in most patent cases, founded on alleged improvements in machines, in order to determine what is the thing patented, it is necessary to inquire:

1. What is the structure or device, described by the patentee, as embodying his invention.
2. What mode of operation is introduced and employed by this structure or device.
3. What result is attained by means of this mode of operation.
4. Does the specification of claim cover the described mode of operation by which the result is attained.

... [T]he structure, described by this patent, is the body of a burden railroad car, made of sheet iron, the upper part being cylindrical, and the lower part in the form of a frustum of a cone, the under edge of which has a flange secured upon it, to which flange a movable

bottom is attached. This bottom is made movable, in order to discharge the load through the aperture left by removing it.

To understand the mode of operation introduced and employed by means of this form of the car body . . . what appears on the face of the specification, and was testified to by experts at the trial as correct, [is] that, by reason of the circular form of the car body, the pressure of the load outwards was equal in every direction, and thus the load supported itself in a great degree; that, by making the lower part conical, this principle of action operated throughout the car, with the exception of the small space to which the movable bottom was attached; that, being conical, the lower part of the car could be carried down below the truck, between the wheels, thus lowering the centre of gravity of the load; that the pressure outwards upon all parts of the circle being equal, the tensile strength of the iron was used to a much greater degree than in a car of a square form; and, finally, that this form of the lower part of the car facilitated the complete discharge of the load through the aperture, when the bottom was removed.

. . .

The practical result attained [by] this mode of operation is correctly described by the patentee . . . . The specification states:

The transportation of coal, and all other heavy articles in lumps, has been attended with great injury to the cars, requiring the bodies to be constructed with great strength to resist the outward pressure on the sides, as well as the vertical pressure on the bottom, due not only to the weight of the mass, but the mobility of the lumps among each other tending to "pack," as it is technically termed. Experience has shown that cars, on the old mode of construction, cannot be made to carry a load greater than its own weight; but, by my improvement, I am enabled to make cars of greater durability than those heretofore made, which will transport double their own weight of coal, &c.

Having thus ascertained what is the structure described, the mode of operation it embodies, and the practical result attained, the next inquiry is, does the specification of claim cover this mode of operation, by which this result is effected?

It was upon this question the case turned at the trial in the Circuit Court.

The testimony showed that the defendants had made cars similar to the plaintiff's, except that the form was octagonal instead of circular. There was evidence tending to prove that, considered in reference to the practical uses of such a car, the octagonal car was substantially the same as the circular. [The defendants' witness] testified[:]

That the advantage of a reduced bottom of the car was obtained, whether the car was conical or octagonal; that the strengthening of the bottom, due to the adoption

## THE INVENTION, THE PATENT, AND THE CLAIM

of a conical form, was the same when the octagonal form was adopted, or the circular. That the circular form was the best to resist the pressure . . . an octagonal one better than the square form; . . . that a polygon of many sides would be equivalent to a circle; that the octagon car, practically, was as good as the conical ones; and that, substantially, the witness saw no difference between the two.

. . .

The substance of [the district court's] ruling was, that the claim was limited to the particular geometrical form mentioned in the specification; and as the defendants had not made cars in that particular form, there could be no infringement, even if the cars made by the defendants attained the same result by employing, what was in fact, the same mode of operation as that described by the patentee. We think this ruling was erroneous.

Under our law a patent cannot be granted merely for a change of form. . . . Merely to change the form of a machine is the work of a constructor, not of an inventor; such a change cannot be deemed an invention. . . . To change the form of an existing machine, and by means of such change to introduce and employ other mechanical principles or natural powers, or, as it is termed, a new mode of operation, and thus attain a new and useful result, is the subject of a patent. Such is the basis on which the plaintiff's patent rests.

Its substance is a new mode of operation, by means of which a new result is obtained. It is this new mode of operation which gives it the character of an invention, and entitles the inventor to a patent; and this new mode of operation is, in view of the patent law, the thing entitled to protection. The patentee may, and should, so frame his specification of claim as to cover this new mode of operation which he has invented; and the only question in this case is, whether he has done so; or whether he has restricted his claim to one particular geometrical form.

. . .

Now, while it is undoubtedly true, that the patentee may so restrict his claim as to cover less than what he invented, or may limit it to one particular form of machine, excluding all other forms, though they also embody his invention, yet such an interpretation should not be put upon his claim if it can fairly be construed otherwise, and this for two reasons:

1. Because the reasonable presumption is, that, having a just right to cover and protect his whole invention, he intended to do so.
2. Because specifications are to be construed liberally, in accordance with the design of the Constitution and the patent laws of the United States, to promote the progress of

## CHAPTER 2

the useful arts, and allow inventors to retain to their own use, not any thing which is matter of common right, but what they themselves have created.

The claim of the plaintiff is in the following words:

What I claim as my invention, and desire to secure by letters-patent, is making the body of a car for the transportation of coal, &c., in the form of a frustum of a cone, substantially as herein described, whereby the force exerted by the weight of the load presses equally in all directions, and does not tend to change the form thereof, so that every part resists its equal proportion, and by which, also, the lower part is so reduced as to pass down within the truck frame and between the axles, to lower the centre of gravity of the load without diminishing the capacity of the car as described.

I also claim extending the body of the car below the connecting pieces of the truck frame, and the line of draught, by passing the connecting bars of the truck frame, and the draught bar, through the body of the car, substantially as described.

It is generally true, when a patentee describes a machine, and then claims it as described, that he is understood to intend to claim, and does by law actually cover, not only the precise forms he has described, but all other forms which embody his invention; it being a familiar rule that, to copy the principle or mode of operation described, is an infringement, although such copy should be totally unlike the original in form or proportions.

Why should not this rule be applied to this case?

It is not sufficient to distinguish this case to say, that here the invention consists in a change of form, and the patentee has claimed one form only.

Patentable improvements in machinery are almost always made by changing some one or more forms of one or more parts, and thereby introducing some mechanical principle or mode of action not previously existing in the machine, and so securing a new or improved result. . . . If the machine complained of were a copy, in form, of the machine described in the specification, of course it would be at once seen to be an infringement. It could be nothing else. It is only ingenious diversities of form and proportion, presenting the appearance of something unlike the thing patented, which give rise to questions; and the property of inventors would be valueless, if it were enough for the defendant to say, your improvement consisted in a change of form; you describe and claim but one form; I have not taken that, and so have not infringed.

The answer is, my improvement did not consist in a change of form, but in the new employment of principles or powers, in a new mode of operation, embodied in a form by means of which a new or better result is produced; it was this which constituted my

invention; this you have copied, changing only the form; and that answer is justly applicable to this patent.

...

Where form and substance . . . are separable; where the whole substance of the invention may be copied in a different form, it is the duty of courts and juries to look through the form for the substance of the invention—for that which entitled the inventor to his patent, and which the patent was designed to secure; where that is found, there is an infringement; and it is not a defence, that it is embodied in a form not described, and in terms claimed by the patentee.

. . . The exclusive right to the thing patented is not secured, if the public are at liberty to make substantial copies of it, varying its form or proportions. And, therefore, the patentee, having described his invention, and shown its principles, and claimed it in that form which most perfectly embodies it, is, in contemplation of law, deemed to claim every form in which his invention may be copied, unless he manifests an intention to disclaim some of those forms.

Indeed it is difficult to perceive how any other rule could be applied, practicably, to cases like this. How is a question of infringement of this patent to be tried? It may safely be assumed, that neither the patentee nor any other constructor has made, or will make, a car exactly circular. In practice, deviations from a true circle will always occur. How near to a circle, then, must a car be, in order to infringe? May it be slightly elliptical, or otherwise depart from a true circle, and, if so, how far?

In our judgment, the only answer that can be given to these questions is, that it must be so near to a true circle as substantially to embody the patentee's mode of operation, and thereby attain the same kind of result as was reached by his invention. It is not necessary that the defendant's cars should employ the plaintiff's invention to as good advantage as he employed it, or that the result should be precisely the same in degree. It must be the same in kind, and effected by the employment of his mode of operation in substance. Whether, in point of fact, the defendant's cars did copy the plaintiff's invention, in the sense above explained, is a question for the jury, and the court below erred in not leaving that question to them upon the evidence in the case, which tended to prove the affirmative.

The judgment of the court below must be reversed.

Mr. Chief Justice TANEY, Mr. Justice CATRON, Mr. Justice DANIEL, and Mr. Justice CAMPBELL, dissented.

## Context & Application

1. What did coal cars look like before Winans produced the alleged invention at issue in the case? How did they work? What kinds of problems were associated with those coal cars? How did Winans's coal car differ from those most commonly used? What advantages did it purportedly offer over existing coal cars?

2. *Winans v. Denmead* is now best known as the case in which the Supreme Court first permitted allegations of infringement to be premised on the basis that the accused device was equivalent to the patented one, even though the accused device did not fall within the literal words of the claim. This approach to infringement, now referred to as the doctrine of equivalents, will be explored in detail in Chapter 9 on Infringement.

3. In the first decades of the American patent system, patents did not have claims. By the mid-1800s, inventors began including in the specification a statement of the form "I claim as my invention . . ." Although *Winans* is now associated with the doctrine of equivalents, its approach to understanding the scope of the patent was typical in its era. The goal in reading the specification and the claims (if there were any claims) was "to allow inventors to retain to their own use, not any thing which is matter of common right, but what they themselves have created." In the Patent Act of 1870, Congress required that inventors include claims that "particularly point out and distinctly claim the part, improvement, or combination which he claims as his invention or discovery." This more pointedly raised the question of how the claims relate to the rest of the specification, as the next case illustrates.

4. One important aspect of the Court's opinion was its understanding of the claim language "the frustum of a cone." What did the Court understand that phrase to mean? How did the Court reach that understanding? In what way did that understanding influence its determination of whether the patent was infringed?

5. Suppose Winans had asked you to draft his patent application. How would you have drafted the claims? Is there anything in the specification that you would have changed from what you read in *Winans*? Bear in mind that Winans would likely have wanted a patent that would both withstand validity challenges and capture a wide range of potential infringers. Other doctrines, novelty and nonobviousness, would prevent Winans from including within the scope of his patent inventions that existed before his work; meanwhile, disclosure doctrines like written description and enablement would prevent Winans from including within the scope of his patent inventions that he could not adequately describe or teach others how to make and use.

6. Suppose Denmead walked into your office with the Winans patent in hand. He asks you for your advice on how to avoid infringement. What would you have told him?

*Merrill v. Yeomans*  
94 U.S. 568 (1876)

MR. JUSTICE MILLER delivered the opinion of the court.

The defendants were dealers in oils, and not manufacturers of them. If the appellant's patent was for a new oil, the product of a mode of treating the oils of that character which he describes in his application, the defendants may be liable . . . . If, however, appellant's patent is only for the mode of treating these oils invented and described by him,—in other words, for his new process of making this new article of hydrocarbon oil,—then it is clear the defendants have not infringed the patent, because . . . they manufactured none of the oils which they bought and sold.

The counsel for appellant here maintain that his patent is for the new article, and is not for the process, though he describes it fully, by which that article is produced. The appellees insist, with equal earnestness, that the patent is exclusively for the process by which the new oil is made.

The issue thus presented must be decided solely upon a correct construction of the plaintiff's patent, and the accompanying specifications, in which, as required by the act of Congress, he makes the statement of his invention.

No such question could have arisen if appellant had used language which clearly and distinctly points out what it is that he claims in his invention.

We use the word 'claim' as distinct from 'description.' It must be conceded that the appellant's specification describes with minuteness and precision both the instrumentality and the process by which he makes the oil in question. . . .

He also describes, though in short terms, the article produced, the main feature of which he declares to be its freedom from the offensive odor which, before his invention, seemed to be an inseparable quality of those oils; and he mentions some of the more important uses to which this deodorized oil is applicable in the arts.

It is fairly to be inferred from this statement, that, if all which is described as new in these specifications is really so, the inventor has a right to a patent for . . . :

[(1)] a new process or mode of distilling heavy hydrocarbon oils, by which they are deprived of their offensive odors[, and (2)] the product of this new process of distillation; namely, the deodorized heavy hydrocarbon oils fitted for use in the arts.

When a man supposes he has made an invention or discovery useful in the arts, and therefore the proper subject of a patent, it is, nine times out of ten, an improvement of some existing article, process, or machine, and is only useful in connection with it. It is

necessary, therefore, for him, in his application to the Patent Office, to describe that upon which he engrafts his invention, as well as the invention itself; and, in cases where the invention is a new combination of old devices, he is bound to describe with particularity all these old devices, and then the new mode of combining them, for which he desires a patent. It thus occurs that, in every application for a patent, the descriptive part is necessarily largely occupied with what is not new, in order to an understanding of what is new.

The act of Congress, therefore, very wisely requires of the applicant a distinct and specific statement of what he claims to be new, and to be his invention. In practice, this allegation of the distinct matters for which he claims a patent comes at the close of the schedule or specification, and is often accompanied by a disclaimer of any title to certain matters before described, in order to prevent conflicts with pre-existing patents.

This distinct and formal claim is, therefore, of primary importance, in the effort to ascertain precisely what it is that is patented to the appellant in this case.

. . . Turning our attention to the first claim, we are compelled to say that the language is far from possessing that precision and clearness of statement with which one who proposes to secure a monopoly at the expense of the public ought to describe the thing which no one but himself can use or enjoy, without paying him for the privilege of doing so. It is as follows:

I claim the above-described new manufacture of the deodorized heavy hydrocarbon oils, suitable for lubricating and other purposes, free from the characteristic odors of hydrocarbon oils, and having a slight smell like fatty oil, from hydrocarbon oils, by treating them substantially as is hereinbefore described.

The word "manufacture" in this sentence is one which is used with equal propriety to express the process of making an article, or the article so made. "The manufacture of hydrocarbon oils" means primarily the making of hydrocarbon oils. It may mean the thing made also. Are there other words in the sentence calculated to throw light on the meaning of this one? [Ed. note: The Court then quoted again from the patent, slightly modifying some of the language:]

I claim the above-described new manufacture of hydrocarbon oils, . . . by treating them substantially as hereinbefore described.

It seems to us that the most natural meaning of these words is, that "I claim this new mode of manufacturing hydrocarbon oils, by treating them as hereinbefore described." This is the meaning which would first suggest itself to the mind. If the product is meant, the words "by treating them substantially as hereinbefore described" are useless. They are not only useless, but embarrassing; for, by the well-settled rules of construing all



instruments, some importance must be attached to them; and, if they are to be regarded at all, they must either refer to the process of making the oils for which the applicant is claiming a patent, or they are intended to limit his claim for a patent for the product to that product only, when produced by treating the oils in the manner before described.

...

We can see no reason why the applicant for the patent, if he had in his mind a claim for the article produced, should have intended so to limit his claim. If the article was the discovery which he sought the exclusive right to make, use, and sell, he was entitled to that monopoly, however produced.

If, however, he had in his own mind only a claim for the process of manufacture by which the article was made, then his reference to the mode of treating the oils from which it came was evidently proper and intelligible.

But the language in the specifications aids us in construing the claim. In the sentence next preceding this claim, he says: "It will also be evident to those skilled in the art that my invention will be used, if the above-mentioned process be worked, to produce the deodorized heavy oils above described from distilled hydrocarbon oils," &c. It is very clear that what he here calls his invention is a thing which produces the deodorized oils, and not the oil itself. So again he says: "From the above it will be obvious that my invention consists in producing heavy hydrocarbon oils, suitable for lubricating and other purposes, and free from the characteristic odor, by distilling from them the volatile matter from which objectionable odors arise." Again he says: "In carrying on my new manufacture of deodorizing heavy oils with this apparatus, I place the oil to be deodorized in the still, and heat it by the fire beneath to the required temperature to commence the operation, the steam being shut off from the coil, and the outlet cock being opened to admit of the expulsion of any water from within the coil." Here the word "manufacture" is used in the sense of the word "process,"—a word which could be substituted for it, without a shade of change in the meaning. As it can here mean nothing else but process, we have a definition of the meaning to be attached to it in other parts of the same paper, if that meaning were otherwise doubtful.

But, apart from these verbal criticisms,—all of which are just, and tend strongly to show what was the invention claimed by appellant,—it is impossible to read the four printed pages of specifications, in which appellant minutely describes his invention, without observing that they are almost wholly directed to the apparatus, the mode of using it, and the peculiar process of distillation, by which the more volatile parts of the heavy oils, which contain the offensive odors, are separated from the main body of the oil, pass over in that process, and leave the remainder free from this great drawback in its use in the arts. Why should this be so, if the applicant for the patent was only looking to the

products as his invention,—the deodorized heavy hydrocarbon oils? If the oil alone was to be patented, by whatever process made, this elaborate description of one particular process was unnecessary.

A strong appeal is made by counsel to give the appellant the benefit of a liberal construction in support of the patent. Cases are cited in which this court has held that, rather than defeat a patent where it appears that a valuable invention has really been made, this court, giving full effect to all that is found in the application on which the Patent Office acted, will uphold that which was really invented, and which comes within any fair interpretation of the patentee's assertion of claim.

We are not disposed to depart from this rule in the present case. There is no question here but that the patent is good for the second claim,—for the superheating coil, with its steam-pipe, &c.; and we are all of opinion that it is good for the process of distillation described in the specifications, by which the heavy hydrocarbon oils are deodorized. It is, therefore, a valid patent for two important matters, well set forth and described. If the patentee is also entitled to a patent for the product of this distillation, and has failed, as we think he has, to obtain it, the law affords him a remedy, by a surrender and reissue. When this is done, the world will have fair notice of what he claims, of what his patent covers, and must govern themselves accordingly.

The growth of the patent system in the last quarter of a century in this country has reached a stage in its progress where the variety and magnitude of the interests involved require accuracy, precision, and care in the preparation of all the papers on which the patent is founded. It is no longer a scarcely recognized principle, struggling for a foothold, but it is an organized system, with well-settled rules, supporting itself at once by its utility, and by the wealth which it creates and commands. The developed and improved condition of the patent law, and of the principles which govern the exclusive rights conferred by it, leave no excuse for ambiguous language or vague descriptions. The public should not be deprived of rights supposed to belong to it, without being clearly told what it is that limits these rights. The genius of the inventor, constantly making improvements in existing patents,—a process which gives to the patent system its greatest value,—should not be restrained by vague and indefinite descriptions of claims in existing patents from the salutary and necessary right of improving on that which has already been invented. It seems to us that nothing can be more just and fair, both to the patentee and to the public, than that the former should understand, and correctly describe, just what he has invented, and for what he claims a patent.

In consistency with these views, we are of opinion that the appellant in this case has described and claimed a patent for the process of deodorizing the heavy hydrocarbon oils, and that he has not claimed as his invention the product of that process.

## Context & Application

1. What problem was Merrill trying to solve? How did he solve it? To what extent does the claim reflect his solution? Could you have drafted a claim for Merrill that would both have withstood a novelty or nonobviousness challenge and also captured the activity of the defendants in this case?

2. Contrast the role that the claim played in *Merrill* with the role that it played in *Winans*. Recall that in *Winans*, the Court saw itself as trying to ensure that inventors could “retain to their own use, not any thing which is matter of common right, but what they themselves have created.” To what extent does that accord with how the Court understood its role in *Merrill*? What might justify the approach to the claim taken in *Merrill*?

3. What did the Court think was ambiguous about the claim language in *Merrill*? What gave rise to the ambiguity? Suppose you had to draft a claim to the process at issue—what would that claim look like? Now suppose you had to draft a claim to the produce at issue—what would that claim look like? The Court in *Merrill* began by identifying a purported ambiguity in the claim language. Go back to *Winans*—can you identify an ambiguity in the claim language that would permit the Court to interpret the patent in that case to cover the accused device?

4. The patent in *Merrill* had, of course, not only a claim but also a specification that described the invention. How did the specification inform the Court’s analysis? How did the Court see the relationship between what Merrill invented, his description of the invention in the specification, and the claims at the end of the patent?



Courts today take yet another approach to understanding the scope of the patent. The case that follows is an emblematic (if perhaps a bit extreme) example of the modern approach to claim scope. As you read it, consider what role the inventor’s contribution plays in the court’s effort to reconcile the claim and specification.

*Liebel-Flarsheim Co. v. Medrad, Inc.*  
358 F.3d 898 (Fed. Cir. 2004)

Judge BRYSON delivered the opinion of the Court.

Appellants Liebel-Flarsheim Company and Mallinckrodt Inc. (collectively, “Liebel”) sued appellee Medrad, Inc. for infringement . . . . The patents claim certain methods and

## CHAPTER 2

devices for use in connection with powered fluid injectors, which can be used to inject fluids into patients during medical procedures. One of the patents, U.S. Patent No. 5,456,669 (“the ‘669 patent”), is drawn to methods of loading powered injectors from the front. A related patent, U.S. Patent No. 5,658,261 (“the ‘261 patent”), is drawn to front-loadable powered injectors and to disposable front-loadable syringes for use in such injectors. . . . [The district court construed the asserted claims to require the use of pressure jackets around the syringes. Because Medrad’s accused injectors did not use pressure jackets, the district court granted summary judgment of noninfringement.]

### I

Powered injectors are used in various medical applications, such as injecting contrast agents into the vascular systems of patients who undergo certain diagnostic imaging procedures. A powered injector ordinarily uses a motor drive that is attached to a syringe plunger. The drive pulls the plunger rearward to draw contrast agent into the syringe and then drives the plunger forward to inject contrast agent through a tube and into the patient. The contrast agent is usually injected into the patient under high pressure.

### A

Liebel asserted that Medrad’s powered injectors infringed seven claims of the ‘669 patent and twenty claims of the ‘261 patent. The ‘669 and ‘261 patents derive from a 1991 application, Ser. No. 712,110 (“the ‘110 application”). Prior to the filing of the ‘110 application, the injectors sold by both Liebel and Medrad required that the syringes be breech loaded, i.e., loaded through the rear of the injectors. Breech loading has disadvantages, including inefficiency in the loading process and the risk of spillage and contamination that can result from disconnecting the syringe from the tube through which contrast agent is delivered to the patient. The ‘110 application and the patents that eventually issued from it were directed to front loading, rather than breech loading, the powered injectors.

The specifications of the ‘669 and ‘261 patents are essentially identical. Each of the embodiments of the injector described in the two patents includes a pressure jacket into which the syringe is inserted. The pressure jacket surrounds the syringe and prevents it from breaking under the internal pressure generated when the contrast agent is injected into the patient. Based largely on the fact that the ‘669 and ‘261 patents do not contain any description of an injector that lacks a pressure jacket, the district court construed all of the asserted claims from those two patents to require a pressure jacket, even though none of the asserted claims expressly refers to a pressure jacket. The district court concluded that “the specification makes clear that the injector includes a pressure jacket.” Based on that observation, the court ruled that “the asserted claims do not cover a jacketless injector,

## THE INVENTION, THE PATENT, AND THE CLAIM

even though the asserted claims might be considered broad enough to disclose a jacketless injector when read without reference to the specification.”

### II

Liebel’s appeal with respect to the asserted claims of the ’669 and ’261 patents turns on whether the common specification of the two patents limits the scope of the asserted claims to injectors that include pressure jackets. We hold that it does not. The asserted claims do not expressly require pressure jackets, and the common specification does not state that a pressure jacket is a required component of the inventions. Moreover, even if the original disclosure supported Medrad’s contention that the invention, as originally conceived, required the use of a pressure jacket, the prosecution history of the ’669 and ’261 patents makes clear that the patentee drafted the asserted claims specifically to cover injectors lacking pressure jackets. In light of the applicants’ clearly stated intention to cover jacketless injectors, any question regarding the support or lack of support for the claims in the original disclosure bears on the issues of priority and validity, not on the issue of claim construction. Accordingly, for the reasons more fully set forth below, we conclude that the district court erred by construing the asserted claims to require pressure jackets.

### A

Claim 10 of the ’669 patent is representative of the asserted claims of the ’669 and ’261 patents. It provides as follows:

A method of loading a tubular replacement syringe into a high pressure power injector for injecting fluid into an animal, the method comprising the steps of:

providing a power injector having:

a syringe receiving opening with a generally circular periphery therein adapted to receive a rearward end of a syringe having a generally circular rim,

a ram and a motor linked to the ram and operable to reciprocate the ram along a segment of a line projecting through the opening; and providing a hollow tubular syringe that includes:

a cylindrical body having an axis, a generally circular rim, a rearward end and a closed forward end with a fluid discharge orifice therein, and

a plunger axially slidable in the body, the syringe body being structurally capable of withstanding, at least from the rim to the orifice, fluid at an operating pressure of at least 100 psi within the interior thereof;

then:

## CHAPTER 2

inserting into the opening, by generally rearward axial movement of the syringe, the rearward end of the body;

rotating the syringe in the opening a fraction of a turn to thereby lock the body around the rim to the injector around the periphery of the opening; and

engaging the plunger with the ram;

then:

energizing the motor and thereby driving the ram forward along the line and parallel to the axis to move the plunger axially forward at a programmed speed to inject the fluid at the operating pressure from within the syringe and through the orifice at a programmed rate into the animal.

Neither claim 10 of the '669 patent nor any of the other asserted claims recites a pressure jacket. The district court, however, construed the claims to require pressure jackets by focusing on the "syringe receiving opening" limitation . . . . After finding that limitation to be ambiguous with respect to the location of the opening, the court looked to the specification and concluded that, because the syringe-receiving opening in each of the embodiments of the invention was located at the front end of a pressure jacket, the "opening" referred to in each of the asserted claims had to be located at the front end of a pressure jacket. Medrad embraces the district court's claim construction analysis and makes the more general argument that because the "pressure-jacketed injector" is the only subject matter described in the specification, that subject matter constitutes the invention itself, not simply a preferred embodiment of a broader invention.

We have had many occasions to cite one or both of the twin axioms regarding the role of the specification in claim construction: On the one hand, claims "must be read in view of the specification, of which they are a part." On the other hand, it is improper to read a limitation from the specification into the claims. . . . We have recognized that "there is sometimes a fine line between reading a claim in light of the specification, and reading a limitation into the claim from the specification." As we have explained, "an inherent tension exists as to whether a statement is a clear lexicographic definition or a description of a preferred embodiment. The problem is to interpret claims 'in view of the specification' without unnecessarily importing limitations from the specification into the claims." . . .

At the outset, we reject the district court's conclusion that the term "opening" should be defined as limited to an opening in a pressure jacket. The specification does not define "opening" restrictively, nor is there anything in the specification that supports the district court's conclusion that the term is ambiguous. The asserted claims refer to the "syringe receiving opening," or simply the "opening," as having various characteristics, but none of the asserted claims state, explicitly or by necessary implication, that the opening must

be formed in or in conjunction with a pressure jacket. Claim 10 of the '669 patent, for example, requires "a ram and a motor linked to the ram and operable to reciprocate the ram along a segment of a line projecting through the opening." The claim further provides that the rearward end of the syringe will be inserted into the opening and rotated in the opening to lock it in place. Thus, the "opening" must be located so that the ram reciprocates along a segment of a line projecting through the opening and so that the rear end of the syringe can be inserted into the opening and affixed to the injector at that point. But the claim language does not suggest that the "opening" must also be located at the front end of a pressure jacket.

Other asserted claims likewise refer to the location of the opening without referring to the location of the opening vis-à-vis a pressure jacket. . . . In each case, the claim specifies the location and structure of the opening while making no mention of a pressure jacket.

In common usage, an opening is simply an aperture, and nothing in the '669 and '261 patents indicates that the term "opening" should be understood to carry with it the requirement that it must always be located in the front of a pressure jacket. Accordingly, contrary to the district court, we find no ambiguity in the term "opening" and no reason to resolve the purported ambiguity by reading that term restrictively. . . .

B

Medrad argues that because all the embodiments described in the common specification of the '669 and '261 patents feature pressure jackets, the claims of those patents must be construed as limited to devices that use pressure jackets. In Medrad's words, when "the subject matter claimed in the patent-in-suit is the *only* subject matter described . . . that subject matter is the invention, and not simply a 'preferred embodiment' of a broader invention."

There are several answers to Medrad's argument. The first is that this court has expressly rejected the contention that if a patent describes only a single embodiment, the claims of the patent must be construed as being limited to that embodiment. Even when the specification describes only a single embodiment, the claims of the patent will not be read restrictively unless the patentee has demonstrated a clear intention to limit the claim scope using "words or expressions of manifest exclusion or restriction."

For example, in *Brookhill–Wilk 1, LLC v. Intuitive Surgical, Inc.*, 334 F.3d 1294, 1301 (Fed. Cir. 2003), the court interpreted the term "remote" broadly to include surgical procedures performed with the surgeon present in the same room as the patient, although the written description only described performing the surgical procedure without the surgeon

## CHAPTER 2

present in the same room as the patient, because “no statement in the written description constituted a limitation on the scope of the invention.” . . .

In this case, the specification does not describe the invention as limited to embodiments having pressure jackets, and none of the other reasons that have been invoked for giving claims a narrow reading are present. Although all the embodiments described in the common specification of the '669 and '261 patents include a pressure jacket, the written description does not contain a clear disavowal of embodiments lacking a pressure jacket. . . . The abstract of the patents states that an “animal fluid injector, replaceable syringe and method of replacement of the syringe in the injector are provided in which the syringe is loadable and unloadable into and from the injector through the open front end of a pressure jacket of the injector.” Although that language can reasonably be understood as constituting a general description of the invention, the quoted passage does not suggest that a pressure jacket is an essential component of the invention, nor is there any language in that passage, or elsewhere in the specification, that disclaims the use of the invention in the absence of a pressure jacket.

### D

Apart from the literal language of the asserted claims and the prosecution history, the doctrine of claim differentiation provides significant added support for Liebel's claim construction. As we noted above, the '669 and '261 patents both contain claims that explicitly recite the requirement of a pressure jacket and that are dependent from asserted independent claims that do not contain such a requirement. In the '669 patent, asserted claim 10 recites a method of loading a tubular replacement syringe into a high pressure power injector without reference to a pressure jacket. Claim 14, which depends from claim 10, adds four limitations that recite the use of a pressure jacket in the process of inserting the syringe. A comparison of claims 10 and 14 makes clear that the only significant distinction between the two is that claim 14 requires the use of a pressure jacket.

. . . As this court has frequently stated, the presence of a dependent claim that adds a particular limitation raises a presumption that the limitation in question is not found in the independent claim. Although that presumption can be overcome if the circumstances suggest a different explanation, or if the evidence favoring a different claim construction is strong, the presumption is un rebutted in this case, as Medrad has offered no alternative explanation for why the “pressure jacket” limitation is found in the dependent claims but not in the corresponding independent claims. In such a setting, where the limitation that is sought to be “read into” an independent claim already appears in a dependent claim, the doctrine of claim differentiation is at its strongest. The doctrine thus substantially undermines Medrad's contention that all of the claims of the '669 and '261 patents require



the presence of a pressure jacket, even though the express requirement of a pressure jacket is found only in certain claims and not in any of the claims asserted in this case.

E

In support of its claim construction, the district court stated, without elaboration, that it is “unlikely that the specification, which was drafted for claims that disclosed an injector that included a pressure jacket, would describe an injector that does not require a pressure jacket, much less enable one skilled in the art to make and use such a device.” Medrad supplements that observation by arguing, also without elaboration, that if the asserted claims are not construed to require a pressure jacket, those claims “would be of doubtful validity.”

This court has frequently alluded to the “familiar axiom that claims should be so construed, if possible, as to sustain their validity.” At the same time, however, the court has “admonished against judicial rewriting of claims to preserve validity.” Accordingly, unless the court concludes, after applying all the available tools of claim construction, that the claim is still ambiguous, the axiom regarding the construction to preserve the validity of the claim does not apply.

...

In this case, the applicants in effect drafted particular claims of the applications that matured into the '669 and '261 patents so as to omit the pressure jacket limitation that had been present in all of the claims of the parent '110 application. . . . [I]t would be improper to disregard the effect of that action on the scope of those claims simply because the claims, if broadly construed, might be vulnerable to a challenge to their priority and validity. Rather, because the proper construction of the claims is clear, the questions of priority and validity are separate issues that must be separately addressed on remand.

...

Reversed and remanded.

## Context & Application

1. What did powered fluid injectors look like before Liebel-Flarsheim produced the alleged invention at issue in the case? How did they work? What kinds of problems were associated with the preexisting powered fluid injectors? How did Liebel-Flarsheim's differ from those and what advantages did it purportedly offer?

2. What role does the specification play in the *Liebel-Flarsheim* court's analysis? How does it compare to the role of the specification in *Winans v. Denmead* and *Merrill v. Yeomans*?

## CHAPTER 2

3. What does the court mean when it cautions against “read[ing] a limitation from the specification into the claims”? Why would that be undesirable? How does it differ from reading a claim “in view of the specification”? Did *Winans* read the claim “in view of the specification” or did it “read a limitation from the specification into the claims”? What about *Merrill*?

4. The *Liebel-Flarsheim* court also relies on the claim differentiation canon. The intuition here is that each claim should cover some variation on the invention; if the scope of coverage was identical, there would be no reason to include both claims. We will explore the claim differentiation canon, along with other claim construction tools, in more detail in our chapter on claim construction.

5. Suppose you wanted to argue that the claim language itself implicitly included the requirement that the invention include a pressure jacket. You also conclude that there is insufficient support for interpreting the “syringe receiving opening” to require a pressure jacket. Is there any other language in the claim would you rely on?

### 3. PATENTABLE SUBJECT MATTER

In order to be eligible for a patent, an applicant must claim patentable subject matter. This might seem tautological: of course you can only obtain a patent on subject matter that is amenable to patenting. And indeed there are many things that seem as though they must qualify as patentable subject matter—a new pencil sharpener, for example, or a new lightbulb. So too are there many things that seem as though they must not qualify as patentable subject matter; poems, the quality of light at sunset, and the feeling of being thirsty all appear to lie well outside the boundaries of patent law.

But hard questions arise when we try to define patent law’s boundaries precisely. Consider again, as we did in Chapter 2, the constitutional clause from which Congress derives the authority to create a patent system:

The Congress shall have the power . . . [t]o promote the Progress of Science and useful Arts, by securing for limited Times to Authors and Inventors the exclusive Right to their respective Writings and Discoveries.

U.S. Const., Art. 1, § 8, cl. 8. This clause does not explicitly refer to patent eligibility. But there may be implicit limits in the references to “Inventors” and “Discoveries,” as well as in the nature of “Progress” that Congress is empowered to promote.

The first patent statute enacted by Congress in 1790 similarly made no explicit mention of patentable subject matter as a distinct doctrine. Nor did the Act of 1793, which redefined patentable subject matter as “any new and useful art, machine, manufacture, or composition of matter, or any new and useful improvement thereof.” But these statutory categories (which survive largely intact in the current version of Section 101 of the Patent Act) implicitly limit the scope of things that can be patented. By the late 1800s, the statutory categories were defined, although some more precisely than others. *See* Sarah R. Burstein, *The “Article of Manufacture” in 1887*, 32 BERKELEY TECH. L.J. 1, 26-31 (2017) (describing the “well-established” view in 1887 that the “statutory classes of invention” were each “separate categories, between which the lines of division are sharply drawn,” even if there were disputes about where some of those lines were, precisely). Still, the (perhaps inevitable) proposition that only patentable things can be patented seems to have been taken mostly for granted in the earliest days of the American patent system.

The roots of modern patentable subject matter doctrine, with its emphasis on judge-made exclusions from the scope of eligible subject matter, emerged in the mid-1800s. In its initial incarnation, the American patent system was a creature of the First Industrial Revolution. Inventors created an array of machines capable of performing manufacturing

tasks more efficiently than humans could on their own. Many of those machines—ranging from the threshing machine (which removed seeds from grain stalks) to the Fourdrinier machine (which turned paper-making from a hand-made craft into an industrial-scale activity)—were the subject of patents, as were industrial processes.

The Second Industrial Revolution soon put pressure on the legal system's understanding of just what it is that can be patented. Inventions harnessed powers of nature that were previously only poorly understood (or even entirely unknown) and that sometimes remained so even as people begin to make use of them. Electricity is the foremost example, but other efforts to deploy an improved scientific understanding of the natural world into our daily lives brought hard questions of patentable subject matter to the bench, where courts began to develop what is now recognized as patentable subject matter doctrine. These technological developments eventually forced the patent system to reconsider its basic foundations.

Further complicating matters, Congress also created two new types of patents—design and plant patents—with their own statutory subject matter provisions. This chapter will focus on utility patents and the patentable subject requirement of § 101; we will address the subject matter requirements that apply to design and plant patents in subsequent chapters.

Note also that patent eligibility has an unsettled relationship to other statutory requirements for obtaining a patent. The ambiguities here are made more challenging by the sometimes-contested terminology applied to the various requirements. We will use the terms “patent eligibility” and “patentable subject matter” to refer to doctrines that determine whether an invention is the kind of thing that might possibly be patented and that flow from the statutory language in Section 101. We will avoid the term “patentability,” which comes up frequently in judicial opinions, but is used inconsistently; at times, it refers to the novelty, nonobviousness, and utility apart from the eligibility requirement and at other times to all four of these requirements together—eligibility, novelty, nonobviousness, and utility.

The relevance of limits on the scope of patent eligibility has ebbed and flowed over time. At times, the legal system has been exceptionally reluctant to deny patents on the grounds that they do not claim patentable subject matter. At other times, including right now, the PTO and the courts frequently invoke patentable subject matter to deny applications and invalidate issued patents.

Immediately prior to the current resurgence of patentable subject matter doctrine, the landscape was dominated by *Diamond v. Chakrabarty*. Doctor Ananda Chakrabarty had applied for a patent claiming bacteria that were capable of breaking down crude oil; the goal was to use these bacteria to help clean the ocean after oil spills. Chakrabarty

produced the bacteria by incorporating plasmids—short strands of genetic material—into the bacteria. Bacteria with the plasmids produced proteins that degraded oil into smaller components, which do not inflict the ecological damage that crude oil does. The bacteria at issue, drawn from the genus *Pseudomonas*, did not naturally incorporate those plasmids.

The Court held that the patentable subject matter requirement did not prevent Chakrabarty from obtaining a claim to the bacteria incorporating the plasmids. Focusing on Section 101’s categories, the Court articulated the following framework for interpreting the statutory boundaries of patentable subject matter:

[T]his Court has read the term “manufacture” in § 101 in accordance with its dictionary definition to mean “the production of articles for use from raw or prepared materials by giving to these materials new forms, qualities, properties, or combinations, whether by hand-labor or by machinery.” Similarly, “composition of matter” has been construed consistent with its common usage to include “all compositions of two or more substances and . . . all composite articles, whether they be the results of chemical union, or of mechanical mixture, or whether they be gases, fluids, powders or solids.” In choosing such expansive terms as “manufacture” and “composition of matter,” modified by the comprehensive “any,” Congress plainly contemplated that the patent laws would be given wide scope.

The relevant legislative history also supports a broad construction. The Patent Act of 1793, authored by Thomas Jefferson, defined statutory subject matter as “any new and useful art, machine, manufacture, or composition of matter, or any new or useful improvement [thereof].” The Act embodied Jefferson’s philosophy that “ingenuity should receive a liberal encouragement.” Subsequent patent statutes in 1836, 1870, and 1874 employed this same broad language. In 1952, when the patent laws were recodified, Congress replaced the word “art” with “process,” but otherwise left Jefferson’s language intact. The Committee Reports accompanying the 1952 Act inform us that Congress intended statutory subject matter to “include *anything under the sun that is made by man.*”

*Diamond v. Chakrabarty*, 447 U.S. 303, 308-09 (1980) (emphasis added).

That last line—that patentable subject matter includes “anything under the sun that is made by man”—aptly characterized the legal system’s approach to eligibility following *Chakrabarty*. Patents issued for inventions ranging from isolated strands of human DNA to a method of exercising a cat with a laser pointer to a method of buying things on the Internet with one click. Perhaps the high point of this era was the Federal Circuit’s decision in *State Street Bank & Trust Co. v. Signature Financial Group*, which affirmed the

## CHAPTER 3

eligibility of business methods and, more generally, anything that “produce[d] a useful, concrete, and tangible result.” 149 F.3d 1368, 1373 (Fed. Cir. 1998).

The exceptionally lax approach to patentable subject matter of the *Chakrabarty/State Street* era came to a close in 2010, with the Supreme Court’s decision in *Bilski v. Kappos*. That was the first of four patentable subject matter cases in five years—a remarkable degree of attention from the Court to a single doctrine in patent law.

The Supreme Court’s recent patentable subject matter quartet—*Bilski*, *Mayo*, *Myriad*, and *Alice*—imposed relatively stringent limits on what can be patented. In doing so, the Court dug deep into the historical development of this doctrine, often relying heavily on cases decided well over a century ago. Because even quite old cases can influence the outcomes in contemporary cases, it is important to have a firm understanding of those old cases. We might therefore begin in the mid- to late-1800s, when something like what is now called patentable subject matter first emerged in courts. That would permit us to track the development of this doctrine as it happened.

But doing so might render it difficult to see why those cases matter now for two reasons. First, because the doctrine was so ill-formed at the time, it can be hard to start picking up its contours in cases decided when patentable subject matter was blended with other doctrines like nonobviousness (which itself developed in the courts at around the same time) and enablement. And second, the more recent cases have at times recast the old ones, such that it is not always apparent just from a reading of the old cases how they might apply today. That is, the current implications of the old cases become clear only in light of how those cases have been read by more recent ones.

We begin with the case that formalized the modern framework for patentable subject matter, *Alice Corp. v. CLS Bank International*. We then go back to the earliest cases to see how we arrived at our current crossroads. That historical development will be reviewed with an eye to understanding how to apply the modern test, as well as the core conceptual issues raised by patentable subject matter. With the historical background in place, we’ll explore how courts have applied the tests recently developed by the Supreme Court. Still, other ways to sequence this material are eminently viable, and you should feel no qualms about moving through this chapter in the order that makes the most sense for your studies. With that said, let’s begin *in media res*, with the Court’s decision in *Alice*.

## A. Patentable Subject Matter: The Modern Framework

*Alice Corp. v. CLS Bank Int'l*  
573 U.S. 208 (2014)

Justice THOMAS delivered the opinion of the Court.

The patents at issue in this case disclose a computer-implemented scheme for mitigating “settlement risk” (*i.e.*, the risk that only one party to a financial transaction will pay what it owes) by using a third-party intermediary. The question presented is whether these claims are patent eligible under 35 U.S.C. § 101, or are instead drawn to a patent-ineligible abstract idea. We hold that the claims at issue are drawn to the abstract idea of intermediated settlement, and that merely requiring generic computer implementation fails to transform that abstract idea into a patent-eligible invention. We therefore affirm the judgment of the United States Court of Appeals for the Federal Circuit.

I

A

Petitioner Alice Corporation is the assignee of several patents [United States Patent Nos. 5,970,479, 6,912,510, 7,149,720, and 7,725,375] that disclose schemes to manage certain forms of financial risk. According to the specification largely shared by the patents, the invention “enables the management of risk relating to specified, yet unknown, future events.” The specification further explains that the “invention relates to methods and apparatus, including electrical computers and data processing systems applied to financial matters and risk management.”

The claims at issue relate to a computerized scheme for mitigating “settlement risk” – *i.e.*, the risk that only one party to an agreed-upon financial exchange will satisfy its obligation. In particular, the claims are designed to facilitate the exchange of financial obligations between two parties by using a computer system as a third-party intermediary.<sup>2</sup>

<sup>2</sup> The parties agree that claim 33 of the '479 patent is representative of the method claims. Claim 33 recites:

“A method of exchanging obligations as between parties, each party holding a credit record and a debit record with an exchange institution, the credit records and debit records for exchange of predetermined obligations, the method comprising the steps of:

## CHAPTER 3

“(a) creating a shadow credit record and a shadow debit record for each stakeholder party to be held independently by a supervisory institution from the exchange institutions;

“(b) obtaining from each exchange institution a start-of-day balance for each shadow credit record and shadow debit record;

“(c) for every transaction resulting in an exchange obligation, the supervisory institution adjusting each respective party’s shadow credit record or shadow debit record, allowing only these transactions that do not result in the value of the shadow debit record being less than the value of the shadow credit record at any time, each said adjustment taking place in chronological order, and

“(d) at the end-of-day, the supervisory institution instructing one of the exchange institutions to exchange credits or debits to the credit record and debit record of the respective parties in accordance with the adjustments of the said permitted transactions, the credits and debits being irrevocable, time invariant obligations placed on the exchange institutions.”

The intermediary creates “shadow” credit and debit records (*i.e.*, account ledgers) that mirror the balances in the parties’ real-world accounts at “exchange institutions” (*e.g.*, banks). The intermediary updates the shadow records in real time as transactions are entered, allowing “only those transactions for which the parties’ updated shadow records indicate sufficient resources to satisfy their mutual obligations.” At the end of the day, the intermediary instructs the relevant financial institutions to carry out the “permitted” transactions in accordance with the updated shadow records, thus mitigating the risk that only one party will perform the agreed-upon exchange.

In sum, the patents in suit claim (1) the foregoing method for exchanging obligations (the method claims), (2) a computer system configured to carry out the method for exchanging obligations (the system claims), and (3) a computer-readable medium containing program code for performing the method of exchanging obligations (the media claims). All of the claims are implemented using a computer; the system and media claims expressly recite a computer, and the parties have stipulated that the method claims require a computer as well.

### B

Respondents CLS Bank International and CLS Services Ltd. (together, CLS Bank) operate a global network that facilitates currency transactions. . . . The District Court held that all of the claims are patent ineligible because they are directed to the abstract idea of “employing a neutral intermediary to facilitate simultaneous exchange of obligations in order to minimize risk.”



## PATENTABLE SUBJECT MATTER

A divided panel of the United States Court of Appeals for the Federal Circuit reversed, holding that it was not “manifestly evident” that petitioner’s claims are directed to an abstract idea. The Federal Circuit granted rehearing *en banc*, vacated the panel opinion, and affirmed the judgment of the District Court in a one-paragraph *per curiam* opinion. . . .

We . . . now affirm.

## II

Section 101 of the Patent Act defines the subject matter eligible for patent protection. It provides:

“Whoever invents or discovers any new and useful process, machine, manufacture, or composition of matter, or any new and useful improvement thereof, may obtain a patent therefor, subject to the conditions and requirements of this title.” 35 U.S.C. § 101.

“We have long held that this provision contains an important implicit exception: Laws of nature, natural phenomena, and abstract ideas are not patentable.” *Association for Molecular Pathology v. Myriad Genetics, Inc.*, 569 U.S. 576 (2013). We have interpreted § 101 and its predecessors in light of this exception for more than 150 years. *Bilski [v. Kappos]*, 561 U.S. 593, 601–602 (2010)]; *see also O’Reilly v. Morse*, 15 How. 62, 112–120 (1854); *Le Roy v. Tatham*, 14 How. 156, 174–175 (1853).

We have described the concern that drives this exclusionary principle as one of pre-emption. Laws of nature, natural phenomena, and abstract ideas are “the basic tools of scientific and technological work.” “Monopolization of those tools through the grant of a patent might tend to impede innovation more than it would tend to promote it,” thereby thwarting the primary object of the patent laws. We have “repeatedly emphasized this . . . concern that patent law not inhibit further discovery by improperly tying up the future use of” these building blocks of human ingenuity.

At the same time, we tread carefully in construing this exclusionary principle lest it swallow all of patent law. At some level, “all inventions . . . embody, use, reflect, rest upon, or apply laws of nature, natural phenomena, or abstract ideas.” Thus, an invention is not rendered ineligible for patent simply because it involves an abstract concept. *See Diamond v. Diehr*, 450 U.S. 175, 187 (1981). “Applications” of such concepts “to a new and useful end,” we have said, remain eligible for patent protection. *Gottschalk v. Benson*, 409 U.S. 63, 67 (1972).

Accordingly, in applying the § 101 exception, we must distinguish between patents that claim the “building blocks” of human ingenuity and those that integrate the building blocks into something more, thereby “transforming” them into a patent-eligible invention. The former “would risk disproportionately tying up the use of the underlying”

## CHAPTER 3

ideas, and are therefore ineligible for patent protection. The latter pose no comparable risk of pre-emption, and therefore remain eligible for the monopoly granted under our patent laws.

### III

In *Mayo Collaborative Services v. Prometheus Laboratories, Inc.*, we set forth a framework for distinguishing patents that claim laws of nature, natural phenomena, and abstract ideas from those that claim patent-eligible applications of those concepts. First, we determine whether the claims at issue are directed to one of those patent-ineligible concepts. If so, we then ask, “what else is there in the claims before us?” To answer that question, we consider the elements of each claim both individually and “as an ordered combination” to determine whether the additional elements “transform the nature of the claim” into a patent-eligible application. We have described step two of this analysis as a search for an “‘inventive concept’”—*i.e.*, an element or combination of elements that is “sufficient to ensure that the patent in practice amounts to significantly more than a patent upon the ineligible concept itself.”<sup>3</sup>

<sup>3</sup> Because the approach we made explicit in *Mayo* considers all claim elements, both individually and in combination, it is consistent with the general rule that patent claims “must be considered as a whole.” *Diamond v. Diehr*, 450 U.S. 175, 188 (1981); see *Parker v. Flook*, 437 U.S. 584, 594.

### A

We must first determine whether the claims at issue are directed to a patent-ineligible concept. We conclude that they are: These claims are drawn to the abstract idea of intermediated settlement.

The “abstract ideas” category embodies “the longstanding rule that an idea of itself is not patentable.” *Benson, supra*, at 67; see also *Le Roy, supra*, at 175 (“A principle, in the abstract, is a fundamental truth; an original cause; a motive; these cannot be patented, as no one can claim in either of them an exclusive right”). . . .

We most recently addressed the category of abstract ideas in *Bilski v. Kappos*, 561 U.S. 593 (2010). The claims at issue in *Bilski* described a method for hedging against the financial risk of price fluctuations. Claim 1 recited a series of steps for hedging risk, including: (1) initiating a series of financial transactions between providers and consumers of a commodity; (2) identifying market participants that have a counterrisk for the same commodity; and (3) initiating a series of transactions between those market participants and the commodity provider to balance the risk position of the first series of consumer transactions. Claim 4 “put the concept articulated in claim 1 into a simple

mathematical formula.” The remaining claims were drawn to examples of hedging in commodities and energy markets.

“All members of the Court agreed” that the patent at issue in *Bilski* claimed an “abstract idea.” Specifically, the claims described “the basic concept of hedging, or protecting against risk.” The Court explained that “hedging is a fundamental economic practice long prevalent in our system of commerce and taught in any introductory finance class.” “The concept of hedging” as recited by the claims in suit was therefore a patent-ineligible “abstract idea, just like the algorithms at issue in *Benson* and *Flook*.”

It follows from our prior cases, and *Bilski* in particular, that the claims at issue here are directed to an abstract idea. Petitioner’s claims involve a method of exchanging financial obligations between two parties using a third-party intermediary to mitigate settlement risk. The intermediary creates and updates “shadow” records to reflect the value of each party’s actual accounts held at “exchange institutions,” thereby permitting only those transactions for which the parties have sufficient resources. At the end of each day, the intermediary issues irrevocable instructions to the exchange institutions to carry out the permitted transactions.

On their face, the claims before us are drawn to the concept of intermediated settlement, *i.e.*, the use of a third party to mitigate settlement risk. Like the risk hedging in *Bilski*, the concept of intermediated settlement is “a fundamental economic practice long prevalent in our system of commerce.” *See, e.g., Emery, Speculation on the Stock and Produce Exchanges of the United States, in 7 STUDIES IN HISTORY, ECONOMICS AND PUBLIC LAW 283, 346–356 (1896)* (discussing the use of a “clearing-house” as an intermediary to reduce settlement risk). The use of a third-party intermediary (or “clearing house”) is also a building block of the modern economy. *See, e.g., Yadav, The Problematic Case of Clearinghouses in Complex Markets, 101 GEO. L.J. 387, 406–412 (2013); J. HULL, RISK MANAGEMENT AND FINANCIAL INSTITUTIONS 103–104 (3d ed. 2012)*. Thus, intermediated settlement, like hedging, is an “abstract idea” beyond the scope of § 101.

Petitioner acknowledges that its claims describe intermediated settlement, but rejects the conclusion that its claims recite an “abstract idea.” Drawing on the presence of mathematical formulas in some of our abstract-ideas precedents, petitioner contends that the abstract-ideas category is confined to “preexisting, fundamental truths” that ““exist in principle apart from any human action.””

*Bilski* belies petitioner’s assertion. The concept of risk hedging we identified as an abstract idea in that case cannot be described as a “preexisting, fundamental truth.” The patent in *Bilski* simply involved a “series of steps instructing how to hedge risk.” Although hedging is a longstanding commercial practice, it is a method of organizing human activity, not a “truth” about the natural world “that has always existed.” One of the claims

in *Bilski* reduced hedging to a mathematical formula, but the Court did not assign any special significance to that fact, much less the sort of talismanic significance petitioner claims. Instead, the Court grounded its conclusion that all of the claims at issue were abstract ideas in the understanding that risk hedging was a “fundamental economic practice.”

## B

Because the claims at issue are directed to the abstract idea of intermediated settlement, we turn to the second step in *Mayo*’s framework. We conclude that the method claims, which merely require generic computer implementation, fail to transform that abstract idea into a patent-eligible invention.

## 1

At *Mayo* step two, we must examine the elements of the claim to determine whether it contains an “inventive concept” sufficient to “transform” the claimed abstract idea into a patent-eligible application. A claim that recites an abstract idea must include “additional features” to ensure “that the claim is more than a drafting effort designed to monopolize the abstract idea.” *Mayo* made clear that transformation into a patent-eligible application requires “more than simply stating the abstract idea while adding the words ‘apply it.’”

*Mayo* itself is instructive. The patents at issue in *Mayo* claimed a method for measuring metabolites in the bloodstream in order to calibrate the appropriate dosage of thiopurine drugs in the treatment of autoimmune diseases. The respondent in that case contended that the claimed method was a patent-eligible application of natural laws that describe the relationship between the concentration of certain metabolites and the likelihood that the drug dosage will be harmful or ineffective. But methods for determining metabolite levels were already “well known in the art,” and the process at issue amounted to “nothing significantly more than an instruction to doctors to apply the applicable laws when treating their patients.” “Simply appending conventional steps, specified at a high level of generality,” was not “enough” to supply an “inventive concept.”

The introduction of a computer into the claims does not alter the analysis at *Mayo* step two. In *Benson*, for example, we considered a patent that claimed an algorithm implemented on “a general-purpose digital computer.” Because the algorithm was an abstract idea, the claim had to supply a “new and useful” application of the idea in order to be patent eligible. But the computer implementation did not supply the necessary inventive concept; the process could be “carried out in existing computers long in use.” We accordingly “held that simply implementing a mathematical principle on a physical machine, namely a computer, is not a patentable application of that principle.”

## PATENTABLE SUBJECT MATTER

*Flook* is to the same effect. There, we examined a computerized method for using a mathematical formula to adjust alarm limits for certain operating conditions (*e.g.*, temperature and pressure) that could signal inefficiency or danger in a catalytic conversion process. Once again, the formula itself was an abstract idea, and the computer implementation was purely conventional. In holding that the process was patent ineligible, we rejected the argument that “implementing a principle in some specific fashion” will “automatically fall within the patentable subject matter of § 101.” Thus, “*Flook* stands for the proposition that the prohibition against patenting abstract ideas cannot be circumvented by attempting to limit the use of [the idea] to a particular technological environment.”

In *Diehr*, by contrast, we held that a computer-implemented process for curing rubber was patent eligible, but not because it involved a computer. The claim employed a “well-known” mathematical equation, but it used that equation in a process designed to solve a technological problem in “conventional industry practice.” The invention in *Diehr* used a “thermocouple” to record constant temperature measurements inside the rubber mold—something “the industry had not been able to obtain.” The temperature measurements were then fed into a computer, which repeatedly recalculated the remaining cure time by using the mathematical equation. These additional steps, we recently explained, “transformed the process into an inventive application of the formula.” In other words, the claims in *Diehr* were patent eligible because they improved an existing technological process, not because they were implemented on a computer.

These cases demonstrate that the mere recitation of a generic computer cannot transform a patent-ineligible abstract idea into a patent-eligible invention. Stating an abstract idea “while adding the words ‘apply it’” is not enough for patent eligibility. Nor is limiting the use of an abstract idea “to a particular technological environment.” Stating an abstract idea while adding the words “apply it with a computer” simply combines those two steps, with the same deficient result. Thus, if a patent’s recitation of a computer amounts to a mere instruction to “implement” an abstract idea “on . . . a computer,” that addition cannot impart patent eligibility. This conclusion accords with the pre-emption concern that undergirds our § 101 jurisprudence. Given the ubiquity of computers, wholly generic computer implementation is not generally the sort of “additional feature” that provides any “practical assurance that the process is more than a drafting effort designed to monopolize the abstract idea itself.”

The fact that a computer “necessarily exists in the physical, rather than purely conceptual, realm,” is beside the point. There is no dispute that a computer is a tangible system (in § 101 terms, a “machine”), or that many computer-implemented claims are formally addressed to patent-eligible subject matter. But if that were the end of the § 101 inquiry, an applicant could claim any principle of the physical or social sciences by

reciting a computer system configured to implement the relevant concept. Such a result would make the determination of patent eligibility “depend simply on the draftsman’s art,” thereby eviscerating the rule that “‘laws of nature, natural phenomena, and abstract ideas are not patentable.’”

2

The representative method claim in this case recites the following steps: (1) “creating” shadow records for each counterparty to a transaction; (2) “obtaining” start-of-day balances based on the parties’ real-world accounts at exchange institutions; (3) “adjusting” the shadow records as transactions are entered, allowing only those transactions for which the parties have sufficient resources; and (4) issuing irrevocable end-of-day instructions to the exchange institutions to carry out the permitted transactions. Petitioner principally contends that the claims are patent eligible because these steps “require a substantial and meaningful role for the computer.” As stipulated, the claimed method requires the use of a computer to create electronic records, track multiple transactions, and issue simultaneous instructions; in other words, “the computer is itself the intermediary.”

In light of the foregoing, the relevant question is whether the claims here do more than simply instruct the practitioner to implement the abstract idea of intermediated settlement on a generic computer. They do not.

Taking the claim elements separately, the function performed by the computer at each step of the process is “purely conventional.” Using a computer to create and maintain “shadow” accounts amounts to electronic recordkeeping—one of the most basic functions of a computer. The same is true with respect to the use of a computer to obtain data, adjust account balances, and issue automated instructions; all of these computer functions are “well-understood, routine, conventional activities” previously known to the industry. In short, each step does no more than require a generic computer to perform generic computer functions.

Considered “as an ordered combination,” the computer components of petitioner’s method “add nothing . . . that is not already present when the steps are considered separately.” Viewed as a whole, petitioner’s method claims simply recite the concept of intermediated settlement as performed by a generic computer. The method claims do not, for example, purport to improve the functioning of the computer itself. Nor do they effect an improvement in any other technology or technical field. Instead, the claims at issue amount to “nothing significantly more” than an instruction to apply the abstract idea of intermediated settlement using some unspecified, generic computer. Under our precedents, that is not “enough” to transform an abstract idea into a patent-eligible invention. [The Court then concluded that the computer system and computer-readable

medium claims fail for “substantially the same reasons.”] For the foregoing reasons, the judgment of the Court of Appeals for the Federal Circuit is affirmed.

### Context and Application

1. *The Alice/Mayo Two-Step.* *Alice* purports to draw its two-step framework from the Court’s decision two years earlier in *Mayo Collaborative Services v. Prometheus Labs.*, 566 U.S. 66 (2012). *Mayo* involved method claims related to thiopurine drugs, which doctors used to treat autoimmune diseases before the invention. Patients did not have reasonably uniform reactions to thiopurine drugs; instead, some patients suffered from serious side effects while others experienced modest or no relief. Doctors had to adjust the dosage of the thiopurine drug until they achieved the desired results. The claimed methods in *Mayo* “help[ed] doctors . . . determine whether a given dosage level is too low or too high.”

In *Mayo*, the Court began by noting that “scientists already understood that the levels in a patient’s blood of certain metabolites, including, in particular, 6–thioguanine and its nucleotides (6–TG) and 6–methyl–mercaptapurine (6–MMP), were correlated with the likelihood that a particular dosage of a thiopurine drug could cause harm or prove ineffective.” Armed with this knowledge, the inventors set out to precisely identify the thiopurine-metabolite thresholds associated with toxicity and inefficacy. The inventors then obtained patents, of which the Court took as typical the following claim:

A method of optimizing therapeutic efficacy for treatment of an immune-mediated gastrointestinal disorder, comprising:

(a) administering a drug providing 6–thioguanine to a subject having said immune-mediated gastrointestinal disorder; and

(b) determining the level of 6–thioguanine in said subject having said immune-mediated gastrointestinal disorder,

wherein the level of 6–thioguanine less than about 230 pmol per  $8 \times 10^8$  red blood cells indicates a need to increase the amount of said drug subsequently administered to said subject and

wherein the level of 6–thioguanine greater than about 400 pmol per  $8 \times 10^8$  red blood cells indicates a need to decrease the amount of said drug subsequently administered to said subject.

The Court concluded that these claims were ineligible. *Alice* included an extensive discussion of the Step Two analysis in *Mayo*, but did not incorporate much about *Mayo*’s analysis at Step One. Here is the entirety of that analysis:

Prometheus' patents set forth laws of nature—namely, relationships between concentrations of certain metabolites in the blood and the likelihood that a dosage of a thiopurine drug will prove ineffective or cause harm. Claim 1, for example, states that *if* the levels of 6-TG in the blood (of a patient who has taken a dose of a thiopurine drug) exceed about 400 pmol per  $8 \times 10^8$  red blood cells, *then* the administered dose is likely to produce toxic side effects. While it takes a human action (the administration of a thiopurine drug) to trigger a manifestation of this relation in a particular person, the relation itself exists in principle apart from any human action. The relation is a consequence of the ways in which thiopurine compounds are metabolized by the body—entirely natural processes. And so a patent that simply describes that relation sets forth a natural law.

*Mayo*, 566 U.S. at 77. Do you see in here a requirement that courts evaluate whether a claim is “directed to” ineligible subject matter? How does the “directed to” analysis in *Mayo* compare to that in *Alice*? Are the claims in each case problematic for the same reasons? We will return to the question of what it means for a claim to be “directed to” ineligible subject matter when we explore post-*Alice* cases.

2. Justice Breyer's majority opinion for a unanimous Court in *Mayo* begins as follows:

Section 101 of the Patent Act defines patentable subject matter. It says: “Whoever invents or discovers any new and useful process, machine, manufacture, or composition of matter, or any new and useful improvement thereof, may obtain a patent therefor, subject to the conditions and requirements of this title. 35 U.S.C. § 101.” The Court has long held that this provision contains an important implicit exception. “Laws of nature, natural phenomena, and abstract ideas” are not patentable. *Diamond v. Diehr*, 450 U.S. 175, 185 (1981); *see also Bilski v. Kappos*, 561 U.S. 593 (2010); *Diamond v. Chakrabarty*, 447 U.S. 303, 309 (1980); *Le Roy v. Tatham*, 14 How. 156, 175 (1853); *O'Reilly v. Morse*, 15 How. 62, 112–120 (1854); *cf. Neilson v. Harford*, Webster's Patent Cases 295, 371 (1841).

Why do you think he began the opinion by quoting statutory language? And why did he then immediately follow with a reference to an implicit judicial exception? What is the relationship between the statutory language and the judicial exception? *Diehr*, *Le Roy*, *O'Reilly*, and *Neilson* will all make appearances in the next subsection of this chapter—when you read them, consider the extent to which they support the proposition for which they are cited here.

3. *Gene patents*. Between *Mayo* and *Alice*, the Court decided *Association for Molecular Pathology v. Myriad Genetics, Inc.*, 569 U.S. 576 (2013). The patents in *Myriad* related to the BRCA1 and BRCA2 genes. Mutations in those genes “can dramatically increase an individual's risk of developing breast and ovarian cancer.” “Before Myriad's discovery of



the BRCA1 and BRCA2 genes, scientists knew that heredity played a role in establishing a woman's risk of developing breast and ovarian cancer, but they did not know which genes were associated with those cancers." Researchers at Myriad "identified the exact location of the BRCA1 and BRCA2 genes on chromosomes 17 and 13." "Once it found the location and sequence of the BRCA1 and BRCA2 genes, Myriad sought and obtained a number of patents."

Some claims in those patents recited "isolated DNA coding for" BRCA1 and BRCA2 proteins and protein fragments with specified sequences of amino acids; other claims recited nucleotide sequences comprising only relevant cDNA exons. Exons comprise the portions of genetic sequences that code for the amino acids that make up proteins; exons exclude everything that does not code for the amino acids. cDNA does not normally occur naturally; instead, scientists create cDNA in the laboratory from mRNA, which cells themselves do produce as part of the ordinary process of making proteins from DNA. The case arose after Myriad asserted that doctors testing their patients for the presence of BRCA1 and BRCA2 mutations infringed its patents on the isolated DNA and cDNA sequences. One such doctor, "along with medical patients, advocacy groups, and other doctors" sought a declaratory judgment that Myriad's patents were invalid. At the time, the Court had not yet decided *Bilski*. The PTO, meanwhile, had been routinely issuing patents on human genes, especially in the wake of 1995 PTO Guidelines that articulated the PTO's view that utility concerns should not stand in the way of issuing biotechnology patents. See 1995 PTO Utility Examination Guidelines, 60 Fed. Reg. 36,263 (July 14, 1995).

The Court decided *Myriad* after deciding *Mayo*. But the two-step framework articulated in *Mayo* and formalized in *Alice* did not play any overt role in *Myriad*. For more on the *Myriad* opinion's curious omission of *Mayo*, see Dan L. Burk, *The Curious Incident of the Supreme Court in Myriad Genetics*, 90 NOTRE DAME L. REV. 505 (2014). Instead, the Court deemed *Chakrabarty* to be "central" to its inquiry, despite its intervening decisions in *Bilski* and *Mayo*. *Myriad* 569 U.S. at 591. Unlike the "new" bacterium "with markedly different characteristics from any found in nature" at issue in *Chakrabarty*, Myriad "did not create anything. To be sure, it found an important and useful gene, but separating that gene from its surrounding genetic material is not an act of invention." Relying on its decision in *Funk Brothers Seed Co. v. Kalo Inoculant Co.*, 333 U.S. 127 (1948), the Court held that Myriad's claim "fell squarely within the law of nature exception" because it "did not alter" the genetic material "in any way." *Myriad*, 569 U.S. at 590-91. The chemical changes required to isolate DNA "from the human genome" were irrelevant because Myriad's "claim is concerned primarily with the information contained in the genetic *sequence*, not with the specific chemical composition of a particular molecule"; the cDNA claims, however, were deemed to be patent eligible because it is "an exons-only molecule that is not naturally occurring." Justice Scalia filed a brief concurrence:

I join the judgment of the Court, and all of its opinion except Part I–A and some portions of the rest of the opinion going into fine details of molecular biology. I am unable to affirm those details on my own knowledge or even my own belief. It suffices for me to affirm, having studied the opinions below and the expert briefs presented here, that the portion of DNA isolated from its natural state sought to be patented is identical to that portion of the DNA in its natural state; and that complementary DNA (cDNA) is a synthetic creation not normally present in nature.

For more on the scientific and business context regarding the *Myriad* litigation, see Jorge Contreras, *Association for Molecular Pathology v. Myriad Genetics: A Critical Reassessment*, 27 MICH. TECH. L. REV. 1 (2020). For a comparative approach to the problem of gene patents, with a focus on Australia’s consideration of Myriad’s claims to the BRCA genes, see Rochelle C. Dreyfuss, Jane Nielsen & Dianne Nicol, *Patenting Nature—A Comparative Perspective*, 5 J.L. & BIOSCI. 550 (2018).

4. The Court asserts in *Alice*—as it does in *Bilski*, *Mayo*, and *Myriad*—that it has “long held that [Section 101] contains an important implicit exception: Laws of nature, natural phenomena, and abstract ideas are not patentable.” *Alice Corp. Pty. v. CLS Bank Int’l*, 573 U.S. 208, 216 (2014). As we’ll see, the Court has long engaged with the patentable subject matter doctrine. But the implicit exceptions to Section 101 have not always been so clear.

Consider the Court’s 2005 grant of *certiorari* in *Laboratory Corp. of America v. Metabolite Labs.*, which it subsequently dismissed as improvidently granted. 548 U.S. 124. The dismissal was over the vigorous dissent of Justices Breyer, Stevens, and Souter. Those Justices indicated that they would have held invalid the claimed process of “using any test (whether patented or unpatented) to measure the level in a body fluid of an amino acid called homocysteine and then noticing whether its level is elevated about the norm; if so, a vitamin deficiency is likely.” The primary reason for dismissing the case was that Section 101 and the “law of nature” objection to the claim was not squarely presented to the district court or the Federal Circuit. Justice Breyer’s dissent contended that LabCorp “argued the essence” of the patentable subject matter issue by asserting that, as construed by the district court, the claim was “too vague because that construction would allow anyone to obtain a patent on any scientific correlation” and “it would permit the respondents improperly to gain a monopoly over a basic scientific fact despite settled law that no such claim should be allowed.” Setting aside the question whether LabCorp’s arguments presented the “essence” of the eligibility issue, we might wonder why LabCorp did not more explicitly frame its arguments in Section 101 terms. One plausible answer is that the Section 101 bases for invalidity were not as clearly defined before the Court’s recent quartet as the Court would like to have you think. As you read the older cases that follow, consider the extent to which you think these exceptions have been

present in the Court's opinions and the extent to which they form three coherent and distinct categories of excluded subject matter.

5. Of the Court's recent quartet of patentable subject matter opinions, *Mayo* and *Alice* were both unanimous, and the only separate opinion in *Myriad* was Justice Scalia's brief concurrence. But the first of these cases, *Bilski v. Kappos*, produced more notable disagreements. While all the Justices agreed that the claims in the application at issue were ineligible, they disagreed about the reasons for their ineligibility. Their disagreement centered on the "machine-or-transformation test," which looks to whether a process "is tied to a particular machine or apparatus" or "transforms a particular article into a different state or thing" and on the patent eligibility of business methods. See *Bilski v. Kappos*, 561 U.S. 593 (2010).

Writing for the Court, Justice Kennedy first concluded that the machine-or-transformation test "is a useful clue," but "is not the sole test for deciding whether an invention is a patent-eligible 'process.'" This part of Justice Kennedy's opinion, however, was only joined in by Chief Justice Roberts and Justices Thomas and Alito. (Justice Scalia joined the remainder of Justice Kennedy's opinion but joined Justice Breyer's concurrence with respect to the machine-or-transformation test.) Second, Justice Kennedy concluded that business methods are not categorically excluded from the scope of patentable subject matter. Nevertheless, Justice Kennedy reasoned that the claims were ineligible because they "explain[ed] the basic concept of hedging, or protecting against risk," which "is a fundamental economic practice long prevalent in our system of commerce and taught in any introductory finance class" "Allowing petitioners to patent risk hedging would preempt use of this approach in all fields, and would effectively grant a monopoly over an abstract idea.

Justice Stevens concurred, joined by Justices Ginsburg, Breyer, and Sotomayor. They would have "restor[ed] patent law to its historical and constitutional moorings" by holding that the claims "describe[d] only a general method of engaging in business transactions—and business methods are not patentable." Suggesting that the Federal Circuit made "a grave mistake" in adopting the "useful, concrete, and tangible result" test in *State Street*, Justice Stevens's concurrence would have concluded that "a claim that merely describes a method of doing business does not qualify as a 'process' under § 101." The opinion is also notable for rejecting the proposition that the text of the statute alone can provide meaningful guidance to the scope of patentable subject matter, and for its extended discussion of "the history of our patent law" (including its English roots) to inform the modern contours of the doctrine.

Justice Breyer, with Justice Scalia joining, concurred in Justice Stevens's conclusion that business methods are not patentable, but wrote separately "to highlight the substantial agreement" on the Court. Justice Breyer's concurrence asserted that both the

Court’s opinion and Justice Stevens’s concurrence were consistent with the following four points: (1) “although the text of § 101 is broad, it is not without limit”; (2) “the so-called ‘machine-or-transformation test,’ has . . . repeatedly helped the Court to determine what is a patentable ‘process’”; (3) “while the machine-or-transformation test has always been a ‘useful and important clue,’ it has never been the ‘sole test’ for determining patentability”; and (4) “although the machine-or-transformation test is not the only test for patentability, this by no means indicates that anything which produces a ‘useful, concrete and tangible result’ is patentable.”

6. The *Bilski-Mayo-Myriad-Alice* quartet has had a massive impact on patent practice. Eligibility challenges are much more commonly raised and much more commonly successful, especially in the wake of *Alice*. According to one study, in the two years before *Alice*, only 26 patents were challenged on § 101 grounds, with 32.1% of those challenges succeeding; in the 32 months after *Alice*, 324 patents were challenged—a more than ten-fold increase—with 41.6% of those challenges succeeding. Software patents have come under particular scrutiny. The same study found that 201 of 325 software patents challenged between June 2014 and February 2017 were deemed ineligible. The two next most-commonly challenged fields of technology, communications and business methods, have significant overlaps with software. Patents in those fields were deemed ineligible in 184 of 283 challenges. All other fields combined to produce 64 ineligibility results in 121 challenges. For more details on this study and a broader assessment of the impacts of *Alice* and the Court’s other recent eligibility cases, see Jeffrey A. Lefstin, Peter S. Menell, & David O. Taylor, *Final Report of the Berkeley Center for Law & Technology Section 101 Workshop: Addressing Patent Eligibility Challenges*, 33 BERKELEY TECH. L.J. 551 (2018). For just some of the literature spawned by the quartet, see Symposium, *The Meaning of Myriad*, 5 U.C. IRVINE L. REV. 973 (2015); Symposium, *Cracking the Code: Ongoing Section 101 Patentability Concerns in Biotechnology and Computer Software*, 82 GEO. WASH. L. REV. 1751 (2014); Symposium, *The Future of Patents: Bilski and Beyond*, 63 STAN. L. REV. 1245 (2011).

7. The Supreme Court has repeatedly focused on “preemption” in its justifications for the patentable subject matter requirement:

We have described the concern that drives this exclusionary principle as one of pre-emption. Laws of nature, natural phenomena, and abstract ideas are the basic tools of scientific and technological work. Monopolization of those tools through the grant of a patent might tend to impede innovation more than it would tend to promote it, thereby thwarting the primary object of the patent laws. We have repeatedly emphasized this . . . concern that patent law not inhibit further discovery by improperly tying up the future use of these building blocks of human ingenuity.

## PATENTABLE SUBJECT MATTER

*Alice*, 573 U.S. 208, 216 (2014). We might wonder when and why preemption is undesirable. Although the Court states that granting exclusivity in “the basic tools of scientific and technological work” could “impede innovation,” the same might be said of patent exclusivity for all kinds of inventions, not just “the basic tools of scientific and technological work.” In other words, the public good justification for the patent system posits that there is a general tradeoff between the dynamic benefits of increased incentives and the static costs of reduced access. What, then, makes laws of nature, natural phenomena, and abstract ideas different?

One common view is that the preemption concern arises from the possibility that laws of nature, natural phenomena, and abstract ideas have a systematically broader impact on downstream innovation than do the kinds of things that fall within the scope of patentable subject matter. The intuition is that the kinds of things that are excluded are frequently used as the foundation for subsequent innovations and that they rarely have independent (commercial?) value. Think of  $E = mc^2$  and all manner of nuclear-related technology power; the former is a law of nature that is used as the foundation for developing technologies that depend on the energy contained in an atom.

But this explanation does not fit well with some of the actual disputes that the Court has confronted. For example, *Mayo* deemed the correlation between thiopurine metabolites and drug efficacy/toxicity to be an unpatentable law of nature. But that correlation doesn't seem likely to be the foundation for a wide array of subsequent innovation; instead, it seems to be limited to helping the set of patients who take these thiopurine drugs. As Katherine Strandburg argues,

The preemption rhetoric is a red herring. A sole focus on broad downstream impact is unsatisfactory, both as a theoretical matter and as an explanation of the Supreme Court's patentable subject matter jurisprudence. Most of the Court's patentable subject matter decisions rely, instead, on the fact that the claims at issue incorporate subject matter that is deemed per se excluded from patentability. Their outcomes turn, not on overbreadth, but on determining whether the inventor's application of per se unpatentable elements is sufficiently inventive to traverse the boundary between unpatentable and patentable terrain. Current doctrinal and theoretical shortcomings and confusion are exacerbated by attempts to shoehorn this type of analysis into a misunderstood preemption mold.

Katherine J. Strandburg, *Much Ado About Preemption*, 50 HOUS. L. REV. 563, 566 (2012). This still leaves the question of why certain subject matter is “per se excluded from patentability.” *Id.* For some plausible explanations, see Tun-Jen Chiang, *Competing Visions of Patentable Subject Matter*, 82 GEO. WASH. L. REV. 1858 (2014) (arguing that normative values, like those related to freedom of thought and the dignity of the human body, justify patentable subject matter exclusions better than do economic concerns arising from the

monopoly costs associated with patent exclusivity); Emily Michiko Morris, *Intuitive Patenting*, 66 S. CAROLINA L. REV. 61 (2014) (arguing that there is no “objective criteria” for determining whether certain subject matter should be excluded and that, instead, courts should simply rely on intuition to draw the boundary between patentable and unpatentable subject matter).

8. The patentable subject matter inquiry appears to require the resolution of some potential factual disputes. For example, the parties might dispute what is “conventional” or “well known in the art.” Despite this possibility, courts have frequently granted motions to dismiss complaints on the basis that the asserted claims covered only ineligible subject matter. Is it appropriate for them to do so? Or should parties have at least an opportunity to engage in discovery before the court decides whether the claims are ineligible?

## B. Patentable Subject Matter: How Did We Get Here?

The origin of patentable subject matter is generally traced to a pair of cases: *Neilson v. Harford* and *Le Roy v. Tatham*. *Neilson*, decided in England, was the first to set (or at least, to appear to set) some boundaries on the kinds of innovations that can be patented. *Le Roy* then brought those boundaries to America.

The patent in *Neilson* related to furnaces. Furnaces of various kinds had been used for millennia. To maintain the extremely high temperatures required for melting metal, furnaces need both fuel (e.g., coal) and air. Bellows were used to blow air into furnaces and engineers had noticed that these furnaces appeared to work better in the winter. This led to the view that the air blown into the furnace should be as cold as possible. The patent in *Neilson*, meanwhile, described heating the air before blowing it into the furnace. From the patent’s specification:

A blast or current of air must be produced by bellows or other blowing apparatus, in the ordinary way, to which mode of producing the blast or current of air this patent is not intended to extend. The blast or current of air so produced is to be passed from the bellows or blowing apparatus into an air-vessel or receptacle, made sufficiently strong to endure the blast, and from that vessel or receptacle, by means of a tube, pipe, or aperture, into the fire, forge, or furnace. The vessel or receptacle must be air-tight, or nearly so, except the apertures for the admission and emission of the air; and at the commencement and during the continuance of the blast, it must be kept artificially heated to a considerable temperature. It is better that the temperature be kept to a red heat, or nearly so; but so high a temperature is not absolutely necessary to produce a beneficial effect. The air-vessel or receptacle may be conveniently made of iron, but as the effect does not

## PATENTABLE SUBJECT MATTER

depend upon the nature of the material, other metals or convenient materials may be used. The size of the air-vessel must depend upon the blast, and upon the heat necessary to be produced. For an ordinary smith's fire or forge, an air-vessel or receptacle capable of containing 1200 cubic inches will be of proper dimensions; and for a cupola of the usual size for cast-iron founders, an air-vessel capable of containing 10,000 cubic inches will be of a proper size. . . . The form or shape of the vessel or receptacle is immaterial to the effect, and may be adapted to the local circumstances or situation. The air-vessel may generally be conveniently heated by a fire distinct from the fire to be affected by the blast or current of air; and generally, it will be better that the air-vessel, and the fire by which it is heated, should be inclosed in brick-work or masonry, through which the pipes or tubes connected with the air-vessel should pass. The manner of applying the heat to the air-vessel is, however, immaterial to the effect, if it be kept at a proper temperature.

The defendant raised a variety of objections to the patent's validity. Some of these appeared to raise questions about the adequacy of the patent's description of the invention, others about the nature of the invention itself:

[T]he alleged invention is not the subject of a patent, because it claims a principle: that the terms in which the subject of the patent is described, viz. "an invention for the improved application of air to produce heat in fires, forges, and furnaces, where bellows and other blowing apparatus are required," are ambiguous, and it is doubtful whether the patent is for the invention of the application of hot air, or only for an improved mode of applying hot air: . . . that the said specification, so far as it can be understood as descriptive of an apparatus for forming and supplying hot air, describes an apparatus which does not answer the purpose: that the said specification is invalid on account of its general vagueness: . . .

The plaintiff responded:

It has been suggested that this is a patent merely for a principle; but that is not so; it is a patent for the mode of carrying a principle into effect. The mode of heating air and increasing combustion was known before; this patent is taken out for the novel application of air so heated to certain useful purposes—for passing the air in a heated state instead of a cold state as formerly, into furnaces; and the mode of operation is by interposing a closed vessel, exposed to heat, between the blowing apparatus and the furnace.

As you read the case, bear in mind that the technology at issue was no minor thing; improvements to furnaces were crucial drivers of the Industrial Revolution, providing iron in the suddenly massive quantities required by a vast array of novel devices.

*Neilson v. Harford*  
151 E.R. 1266 (1841)

The judgment of the Court was now delivered by Parke, B.

[The Court first evaluated whether the construction of the specification was a question for the jury or the judge. Concluding that the judge was responsible, the Court went on to construe the specification.]

Then, taking the construction of this specification on ourselves, . . . it becomes necessary to examine what the nature of the invention is which the plaintiff has disclosed by this instrument. It is very difficult to distinguish it from the specification of a patent for a principle, and this at first created in the minds of some of the Court much difficulty; but, after full consideration, we think that the plaintiff does not merely claim a principle, but a machine embodying a principle, and a very valuable one. We think the case must be considered as if, the principle being well known, the plaintiff had first invented a mode of applying it by a mechanical apparatus to furnaces; and his invention then consists in this—the interposing a receptacle for heated air between the blowing apparatus and the furnace. In this receptacle he directs the air to be heated, by the application of heat externally to the receptacle, and thus he accomplishes the object of applying the blast, which before was of cold air, in a heated state to the furnace.

Now in this specification, after stating that air heated up to a red heat may be used, but that it is not necessary to go so far to produce a beneficial effect, he proceeds to state that the size of the receptacle will depend on the blast necessary for the furnace, and gives directions as to that; and then he adds, the shape of the receptacle “is immaterial to the effect, and may be adapted to local circumstances.” It is this part of the specification which has raised the difficulty. At the trial I construed this passage as meaning that the shape was immaterial to the degree of effect in heating the blast; and if this were so, the jury having, by their finding, negated the truth and accuracy of this statement, the specification would be bad, as containing a false statement in a material circumstance, of a nature that, if literally acted upon by a competent workman, it would mislead him, and cause the experiment to fail. Nor do we think that the point contended for by Sir W. Follett, that if a man acquainted with the process of heating air were employed, the mis-statement could not mislead him, would at all relieve the plaintiff from the difficulty; for this would be to support the specification by a fresh invention and correction by a scientific person; and no authority can be found that, in such a case, a specification would be good. To be valid, we think it should be such as, if fairly followed out by a competent workman, without invention or addition, would produce the machine for which a patent is taken out, and that such machine, so constructed, must be one beneficial to the public.



...

The word “effect” occurs four times in this specification; and it is a just rule of construction, to judge of the meaning of a particular phrase by taking the whole instrument together. In the first sentence, the patentee, speaking of the temperature being so high as that of a red heat, adds, “that so high a temperature is not absolutely necessary to produce a beneficial effect;” then he adds, that the receptacle may be made of iron, “but as the effect does not depend upon the nature of the material, other metals or convenient materials may be used.” Here he cannot mean that all metals, or convenient materials, will equally be heated by the application of external fire, for some heat more easily, and others more slowly; but he means that the quantity of the heated air, whether heated in an air-vessel or any other (if heated at a proper temperature), will not materially alter the beneficial effect on the furnace to which it is applied. “Effect” here, then, is equivalent to a beneficial effect; and the sense of the passage is this, — “but as the effect, to be a beneficial effect, does not depend on the nature of the material,” and so forth. The same is, we think, obviously the meaning of the word “effect,” in the concluding sentence of the specification — “the manner of applying the heat to the air-vessel is, however, immaterial to the effect, if it be kept at a proper temperature;” in other words, the effect will be a beneficial effect on the furnace, whatever be the manner in which you apply heat to the air-vessel, provided only that you so apply it as to raise its temperature sufficiently. Then if so, it is not unreasonable, we think, to construe the word “effect,” in the sentence on which this question turns, in a similar way, and to hold it to mean an assertion by the patentee, that though the size of the vessel must be regulated as directed, yet the shape of the air-vessel is immaterial to the effect; that is to say, any shape will produce a beneficial effect, and may be adapted to local circumstances. Now if this be so, still it casts upon him the necessity of proving, to the satisfaction of the jury, that any shape in which the air-vessel could reasonably be expected to be made by a competent workman, would produce a beneficial effect, and be a valuable discovery. On the present occasion we are bound, as to this point, by the finding of the jury, who have arrived at this conclusion of fact; and if they are right, we think the verdict was not correctly entered for the defendants on this 4th issue, but that it should have been entered for the plaintiffs. . . .

*Le Roy v. Tatham*  
55 U.S. 156 (1852)

Mr. Justice McLEAN delivered the opinion of the court. . . .

[John and Charles Hanson were the named inventors on a patent, which they assigned to Henry and Benjamin Tatham. The Tathams assigned an undivided third of the patent to George Tatham. The Tathams then sued Le Roy and others] to recover damages for an

alleged infringement of a patent for new and useful improvements in machinery for making pipes and tubes from metallic substances.

...

The schedule, which is annexed to the patent, and forms a part of it, states that the invention consists "in certain improvements upon, and additions to, the machinery used for manufacturing pipes and tubes from lead or tin, or an alloy of soft metals capable of being forced, by great pressure, from out of a receiver, through or between apertures, dies, and cores, when in a set or solid state," . . . the patentees say, "Pipes thus made are found to possess great solidity and unusual strength, and a fine uniformity of thickness and accuracy of bore is arrived at, [which], it is believed, has never before been attained by any other machinery."

"The essential difference in the character of this pipe, which distinguishes it . . . from all other heretofore known or attempted, is that it is wrought under heat, by pressure and constriction, from set metal; . . . it is not a casting formed in a mould."

. . . "We do not claim as our invention and improvement, any of the parts of the above-described machinery, independently of its arrangement and combination above set forth. What we do claim as our invention, and desire to secure, is, the combination of the following parts above described, to wit: the core and bridge, or guide-piece, with the cylinder, the piston, the chamber and the die, when used to form pipes of metal, under heat and pressure, in the manner set forth, or in any other manner substantially the same."

The plaintiffs gave in evidence . . . tending to prove . . . "that the lead pipe manufactured thereby, was superior in quality and strength, capable of resisting much greater pressure, and more free from defects than any pipe before made; that in all the modes of making lead pipe, previously known and in use, it could be made only in short pieces, but that by this improved mode it could be made of any required length, and also of any required size; . . ."

"And the plaintiffs also gave evidence tending to prove that lead, when recently become set, and while under heat and extreme pressure in a close vessel, would reunite perfectly, after a separation of its parts; and that in the process described in the said patent, lead pipe was manufactured by being thus separated and reunited . . ."

...

The word *principle* is used by elementary writers on patent subjects, and sometimes in adjudications of courts, with such a want of precision in its application, as to mislead. It is admitted, that a principle is not patentable. A principle, in the abstract, is a fundamental truth; an original cause; a motive; these cannot be patented, as no one can claim in either of them an exclusive right. Nor can an exclusive right exist to a new power, should one be

## PATENTABLE SUBJECT MATTER

discovered in addition to those already known. Through the agency of machinery a new steam power may be said to have been generated. But no one can appropriate this power exclusively to himself, under the patent laws. The same may be said of electricity, and of any other power in nature, which is alike open to all, and may be applied to useful purposes by the use of machinery.

In all such cases, the processes used to extract, modify, and concentrate natural agencies, constitute the invention. The elements of the power exist; the invention is not in discovering them, but in applying them to useful objects. Whether the machinery used be novel, or consist of a new combination of parts known, the right of the inventor is secured against all who use the same mechanical power, or one that shall be substantially the same.

A patent is not good for an effect, or the result of a certain process, as that would prohibit all other persons from making the same thing by any means whatsoever. This, by creating monopolies, would discourage arts and manufactures, against the avowed policy of the patent laws.

A new property discovered in matter, when practically applied, in the construction of a useful article of commerce or manufacture, is patentable; but the process through which the new property is developed and applied, must be stated, with such precision as to enable an ordinary mechanic to construct and apply the necessary process. This is required by the patent laws of England and of the United States, in order that when the patent shall run out, the public may know how to profit by the invention. It is said, in . . . *Househill Company v. Neilson*, Webster's Patent Cases, 683, "A patent will be good, though the subject of the patent consists in the discovery of a great, general, and most comprehensive principle in science or law of nature, if that principle is by the specification applied to any special purpose, so as thereby to effectuate a practical result and benefit not previously attained." In that case, Mr. Justice Clerk . . . said, "the specification does not claim any thing as to the form, nature, shape, materials, numbers, or mathematical character of the vessel or vessels in which the air is to be heated, or as to the mode of heating such vessels," &c. The patent was for "the improved application of air to produce heat in fires, forges and furnaces, where bellows or other blowing apparatus are required."

In that case, although the machinery was not claimed as a part of the invention, the jury were instructed to inquire, "whether the specification was not such as to enable workmen of ordinary skill to make machinery or apparatus capable of producing the effect set forth in said letters-patent and specification." [I]n order to ascertain whether the defendants had infringed the patent, the jury should inquire whether they [used] "machinery or apparatus substantially the same with the machinery or apparatus described in the plaintiffs' specification, and to the effect set forth in said letters-patent

and specification.” So it would seem that where a patent is obtained, without a claim to the invention of the machinery, through which a valuable result is produced, a precise specification is required; and the test of infringement is, whether the defendants have used substantially the same process to produce the same result.

In the case before us, the court instructed the jury that the invention did not consist “in the novelty of the machinery, but in bringing a newly discovered principle into practical application, by which a useful article of manufacture is produced, and wrought pipe made as distinguished from cast pipe.”

A patent for leaden pipes would not be good, as it would be for an effect, and would, consequently, prohibit all other persons from using the same article, however manufactured. Leaden pipes are the same, the metal being in no respect different. Any difference in form and strength must arise from the mode of manufacturing the pipes. The new property in the metal claimed to have been discovered by the patentees, belongs to the process of manufacture, and not to the thing made.

But we must look to the claim of the invention stated in their application by the patentees. They say, “We do not claim as our invention and improvement any of the parts of the above described machinery, independently of their arrangement and combination above set forth.” “What we claim as our invention . . . is, the combination of the following parts above described, to wit, the core and bridge or guide-piece, the chamber, and the die, when used to form pipes of metal, under heat and pressure, in the manner set forth, or in any other manner substantially the same.”

The patentees have founded their claim on this specification, and they can neither modify nor abandon it in whole or in part. The combination of the machinery is claimed, through which the new property of lead was developed, as a part of the process in the structure of the pipes. But the jury were instructed, “that the originality of the invention did not consist in the novelty of the machinery, but in bringing a newly discovered principle into practical application.” The patentees claimed the combination of the machinery as their invention in part, and no such claim can be sustained without establishing its novelty—not as to the parts of which it is composed, but as to the combination. The question whether the newly developed property of lead, used in the formation of pipes, might have been patented, if claimed as developed, without the invention of machinery, was not in the case.

...

We think there was error in the above instruction, that the novelty of the combination of the machinery, specifically claimed by the patentees as their invention, was not a material fact for the jury, and that on that ground, the judgment must be reversed. The

other rulings of the court excepted to, we shall not examine, as they are substantially correct.

### Context and Application

1. *Neilson* and *Le Roy* are often relied upon as the earliest patentable subject matter cases. Can you apply the *Alice* two-step analysis to the inventions in those cases? From what you read of the patent documents in those cases, which were quite different from the patents you would read today, do you think the claims were “directed to” potentially ineligible subject matter? If so, can you identify an “inventive application” that would save the claims?

2. The Supreme Court has taken to citing *Neilson* and *Le Roy* as support for its “inventive application” requirement. In the modern framework, that requirement has been relied on to reject claims that engage in “well-understood, routine, conventional activities.” *Alice*, 573 U.S. 208, 225 (2014). The idea appears to be that the discovery of a law of nature, natural phenomena, or abstract idea is insufficient to sustain a claim; instead, the patent system demands that the claim reflect some additional innovative contribution. But the discussion of patenting “principles” in *Neilson* and *Le Roy* appears to point in a different direction. Rather than requiring that the claim incorporate some innovation in addition to the ineligible subject matter, those cases seem to demand that the specification render it relatively straightforward for a skilled artisan to apply the ineligible subject matter to achieve a useful result. In other words, the concern expressed in the cases is that the specification enable the practical use of the ineligible subject matter. This contrasts with the modern demand that the specification reveal some innovation above and beyond the ineligible subject matter. For more on this reading of *Neilson* and *Le Roy*, as well as the subsequent development of the inventive application requirement, see Jeffrey A. Lefstin, *Inventive Application: A History*, 67 FLA. L. REV. 565 (2015).



In addition to *Neilson* and *Le Roy*, one more mid-1800s decision continues to play a prominent role in contemporary patentable subject matter jurisprudence: *O’Reilly v. Morse*, 56 U.S. 62 (1853). The case involved Samuel Morse’s efforts to patent his contributions to the development of the telegraph. Before evaluating the claim, the Court noted “the first fact of electro-magnetism was discovered by Oersted, of Copenhagen,” in the winter of 1819-20. Although “men of science” believed that “this newly-discovered power might be used to communicate intelligence to distant places,” they faced a significant obstacle:

## CHAPTER 3

The great difficulty in their way was the fact that the galvanic current, however strong in the beginning, became gradually weaker as it advanced on the wire; and was not strong enough to produce a mechanical effect, after a certain distance had been traversed. But, encouraged by the discoveries which were made from time to time, and strong in the belief that an electro-magnetic telegraph was practicable, many eminent and scientific men in Europe, as well as in this country, became deeply engaged in endeavoring to surmount what appeared to be the chief obstacle to its success.

The excerpt below focuses on the Court's analysis of claim 8 of Morse's patent. Pay attention not only to the grounds on which the Court thinks the claim is vulnerable but also the Court's understanding of the bases for decision in *Neilson* and *Le Roy*.

*O'Reilly v. Morse*  
56 U.S. 62 (1853)

Mr. Chief Justice TANEY delivered the opinion of the court.

[After rejecting other arguments for invalidating all of Morse's claims, the Court said that "the difficulty arises on" claim 8, specifically with the following language]:

I do not propose to limit myself to the specific machinery or parts of machinery described in the foregoing specification and claims; the essence of my invention being the use of the motive power of the electric or galvanic current, which I call electro-magnetism, however developed for marking or printing intelligible characters, signs, or letters, at any distances, being a new application of that power of which I claim to be the first inventor or discoverer.

It is impossible to misunderstand the extent of this claim. He claims the exclusive right to every improvement where the motive power is the electric or galvanic current, and the result is the marking or printing intelligible characters, signs, or letters at a distance.

If this claim can be maintained, it matters not by what process or machinery the result is accomplished. For aught that we now know some future inventor, in the onward march of science, may discover a mode of writing or printing at a distance by means of the electric or galvanic current, without using any part of the process or combination set forth in the plaintiff's specification. His invention may be less complicated—less liable to get out of order—less expensive in construction, and in its operation. But yet if it is covered by this patent the inventor could not use it, nor the public have the benefit of it without the permission of this patentee.

Nor is this all, while he shuts the door against inventions of other persons, the patentee would be able to avail himself of new discoveries in the properties and powers of electro-magnetism which scientific men might bring to light. For he says he does not confine his claim to the machinery or parts of machinery, which he specifies; but claims for himself a monopoly in its use, however developed, for the purpose of printing at a distance. New discoveries in physical science may enable him to combine it with new agents and new elements, and by that means attain the object in a manner superior to the present process and altogether different from it. And if he can secure the exclusive use by his present patent he may vary it with every new discovery and development of the science, and need place no description of the new manner, process, or machinery, upon the records of the patent office. And when his patent expires, the public must apply to him to learn what it is. In fine he claims an exclusive right to use a manner and process which he has not described and indeed had not invented, and therefore could not describe when he obtained his patent. The court is of opinion that the claim is too broad, and not warranted by law.

...

[The Court then turned to *Neilson*, the hot-blast furnaces patent case:]

[T]he defendant . . . insisted—that the machinery for heating the air and throwing it hot into the furnace was not sufficiently described in the specification, and the patent void on that account—and also, that a patent for throwing hot air into the furnace, instead of cold, and thereby increasing the intensity of the heat, was a patent for a principle, and that a principle was not patentable.

Upon the first of these defences, the jury found that a man of ordinary skill and knowledge of the subject, looking at the specification alone, could construct such an apparatus as would be productive of a beneficial result, sufficient to make it worth while to adapt it to the machinery in all cases of forges, cupolas, and furnaces, where the blast is used.

And upon the second ground of defence, Baron Parke, who delivered the opinion of the court, said:

It is very difficult to distinguish it from the specification of a patent for a principle, and this at first created in the minds of the court much difficulty; but after full consideration we think that the plaintiff does not merely claim a principle, but a machine, embodying a principle, and a very valuable one. We think the case must be considered as if the principle being well known, the plaintiff had first invented a mode of applying it by a mechanical apparatus to furnaces, and his invention then consists in this: by interposing a receptacle for heated air between the blowing apparatus and the furnace. In this receptacle he directs the air to be heated by the

application of heat externally to the receptacle, and thus he accomplishes the object of applying the blast, which was before cold air, in a heated state to the furnace.

We see nothing in this opinion differing in any degree from the familiar principles of law applicable to patent cases. Neilson claimed no particular mode of constructing the receptacle, or of heating it. He pointed out the manner in which it might be done; but admitted that it might also be done in a variety of ways; and at a higher or lower temperature; and that all of them would produce the effect in a greater or less degree, provided the air was heated by passing through a heated receptacle. And hence it seems that the court at first doubted, whether it was a patent for any thing more than the discovery that hot air would promote the ignition of fuel better than cold. And if this had been the construction, the court, it appears, would have held his patent to be void; because the discovery of a principle in natural philosophy or physical science, is not patentable.

But after much consideration, it was finally decided that this principle must be regarded as well known, and that the plaintiff had invented a mechanical mode of applying it to furnaces; and that his invention consisted in interposing a heated receptacle, between the blower and the furnace, and by this means heating the air after it left the blower, and before it was thrown into the fire. Whoever, therefore, used this method of throwing hot air into the furnace, used the process he had invented, and thereby infringed his patent, although the form of the receptacle or the mechanical arrangements for heating it, might be different from those described by the patentee. For whatever form was adopted for the receptacle, or whatever mechanical arrangements were made for heating it, the effect would be produced in a greater or less degree, if the heated receptacle was placed between the blower and the furnace, and the current of air passed through it.

. . . [H]is patent was supported, because he had invented a mechanical apparatus, by which a current of hot air, instead of cold, could be thrown in. And this new method was protected by his patent. The interposition of a heated receptacle, in any form, was the novelty he invented.

We do not perceive how the claim in the case before us, can derive any countenance from this decision. If the Court of Exchequer had said that Neilson's patent was for the discovery, that hot air would promote ignition better than cold, and that he had an exclusive right to use it for that purpose, there might, perhaps, have been some reason to rely upon it. But the court emphatically denied this right to such a patent. And his claim, as the patent was construed and supported by the court, is altogether unlike that of the patentee before us.

For Neilson discovered, that by interposing a heated receptacle between the blower and the furnace, and conducting the current of air through it, the heat in the furnace was increased. And this effect was always produced, whatever might be the form of the



## PATENTABLE SUBJECT MATTER

receptacle, or the mechanical contrivances for heating it, or for passing the current of air through it, and into the furnace.

But Professor Morse has not discovered, that the electric or galvanic current will always print at a distance, no matter what may be the form of the machinery or mechanical contrivances through which it passes. You may use electro-magnetism as a motive power, and yet not produce the described effect, that is, print at a distance intelligible marks or signs. To produce that effect, it must be combined with, and passed through, and operate upon, certain complicated and delicate machinery, adjusted and arranged upon philosophical principles, and prepared by the highest mechanical skill. And it is the high praise of Professor Morse, that he has been able, by a new combination of known powers, of which electro-magnetism is one, to discover a method by which intelligible marks or signs may be printed at a distance. And for the method or process thus discovered, he is entitled to a patent. But he has not discovered that the electro-magnetic current, used as motive power, in any other method, and with any other combination, will do as well.

[The Court then turned to *Leroy v. Tatham*:] [T]he patentee had discovered that lead, recently set, would, under heat and pressure in a close vessel, reunite perfectly, after a separation of its parts, so as to make wrought, instead of cast pipe. And the court held that he was not entitled to a patent for this newly-discovered principle or quality in lead; and that such a discovery was not patentable. But that he was entitled to a patent for the new process or method in the art of making lead pipe, which this discovery enabled him to invent and employ; and was bound to describe such process or method, fully, in his specification.

...

Indeed, independently of judicial authority, we do not think that the language used in the act of Congress, can justly be expounded otherwise.

The 5th section of the act of 1836, declares that a patent shall convey to the inventor for a term not exceeding fourteen years, the exclusive right of making, using, and vending to others to be used, his invention or discovery; referring to the specification for the particulars thereof.

The 6th section . . . provides that any person shall be entitled to a patent who has discovered or invented a new and useful art, machine, manufacture, or composition of matter; or a new and useful improvement on any previous discovery in either of them. But before he receives a patent, he shall deliver a written description of his invention or discovery, "and of the manner and process of making, constructing, using, and compounding the same," in such exact terms as to enable any person skilled in the art or science to which it appertains, or with which it is most nearly connected, to make, construct, compound, and use the same.

## CHAPTER 3

This court has decided, that the specification required by this law is a part of the patent; and that the patent issues for the invention described in the specification.

Now whether the Telegraph is regarded as an art or machine, the manner and process of making or using it must be set forth in exact terms. The act of Congress makes no difference in this respect between an art and a machine. An improvement in the art of making bar iron or spinning cotton must be so described; and so must the art of printing by the motive power of steam. And in all of these cases it has always been held, that the patent embraces nothing more than the improvement described and claimed as new, and that any one who afterwards discovered a method of accomplishing the same object, substantially and essentially differing from the one described, had a right to use it. Can there be any good reason why the art of printing at a distance, by means of the motive power of the electric or galvanic current, should stand on different principles? Is there any reason why the inventor's patent should cover broader ground? It would be difficult to discover any thing in the act of Congress which would justify this distinction. The specification of this patentee describes his invention or discovery, and the manner and process of constructing and using it; and his patent, like inventions in the other arts above mentioned, covers nothing more.

The provisions of the acts of Congress in relation to patents may be summed up in a few words.

Whoever discovers that a certain useful result will be produced, in any art, machine, manufacture, or composition of matter, by the use of certain means, is entitled to a patent for it; provided he specifies the means he uses in a manner so full and exact, that any one skilled in the science to which it appertains, can, by using the means he specifies, without any addition to, or subtraction from them, produce precisely the result he describes. And if this cannot be done by the means he describes, the patent is void. And if it can be done, then the patent confers on him the exclusive right to use the means he specifies to produce the result or effect he describes, and nothing more. And it makes no difference, in this respect, whether the effect is produced . . . by the application of discoveries or principles in natural philosophy known or unknown before his invention . . . . In either case he must describe the manner and process as above mentioned, and the end it accomplishes. And any one may lawfully accomplish the same end without infringing the patent, if he uses means substantially different from those described.

Indeed, if the eighth claim of the patentee can be maintained, there was no necessity for any specification, further than to say that he had discovered that, by using the motive power of electro-magnetism, he could print intelligible characters at any distance. We presume it will be admitted on all hands, that no patent could have issued on such a specification. Yet this claim can derive no aid from the specification filed. It is outside of it, and the patentee claims beyond it. And if it stands, it must stand simply on the ground

PATENTABLE SUBJECT MATTER

that the broad terms abovementioned were a sufficient description, and entitled him to a patent in terms equally broad. In our judgment the act of Congress cannot be so construed.

The patent then being illegal and void, so far as respects the eighth claim . . . .



While the earliest patentable subject matter cases involved inventions in the physical and mechanical fields, innovations arising from advancements in biology have consistently presented some of the thorniest eligibility problems. The next pair of cases, *Parke-Davis v. H.K. Mulford* and *Funk Bros. Seed Co. v. Kalo Inoculant Co.*, introduce some persistent themes regarding the relationship between what is claimed and what is, in some sense, found in nature.

*Parke-Davis v. H.K. Mulford*  
189 F. 95 (S.D.N.Y 1911)

HAND, District Judge.

I will first take up the consideration of [Patent] No. 730,176. . . .

The anticipations I will deal with first, because, in the view which I have taken of the two patents, that is the simpler consideration. The patentee originally attempted to claim the active principle itself. This was in his first application where he claimed process and product; but the examiner would not allow these claims, basing his rejection upon his interpretation of *American Wood Paper Co. v. Fibre Disintegrating Co.*, 23 Wall. 566, that no product is patentable, . . . which is merely separated by the patentee from its surrounding materials and remains unchanged. After some argument upon this score, the patentee voluntarily divided out the product patents expressing such intention on December 22, 1902. When he came to file his product patent, he proceeded upon the same theory, first claiming the active principle of the glands. The examiner required a division, but raised no objection to the form in which these claims were given. In his amendment of March 13, 1903, which was about two months after his first application, he changed all the claims so that they read substantially as they do at present and were not limited to the active principle. I think that this effected a substantial change in meaning, and that the defendant is right in insisting that the claims are now broader than a mere claim for the chemically free base, or active principle, and that they cover any substance which possesses the physiological characteristics of the glands and is substantially pure. By doing this, Takamine therefore laid himself open to any anticipation which was a substance of that character, even though the substance did not contain the chemically pure base.

. . . Nevertheless, as I have already said, the claims of patent No. 730,176 do not cover a salt and are especially designed to exclude a salt. It so happens, moreover, that all of four alleged anticipating products never existed except in the form of a salt. . . . the only necessary question here is: Since they were not actually themselves bases, whether pure or impure, whether it involved invention to produce the base of Takamine. This question does not deserve any extended consideration. The difficulties of the old products were so great as made any substantial advance from them important. It is enough that Takamine was the first to isolate any base whatever, all other products existing in the form of a salt, because prior investigators were all trying to reduce the principle down as purely as possible. The invention was therefore novel.

. . .

Nor do any of the claims call for only an 'effect.' That rule I understand to mean nothing more than that the claims must not be too abstract. I do not think that any of the claims in the patent are at all abstract, but each forms a concrete enough criterion to test the product intended. There is no claim which selects a single characteristic or function. The very phrase 'physiological characteristics and reactions of the suprarenal glands' refers to some 15 lines of the specification (page 2, lines 102-116), and this phrase is always coupled with at least two other differentia. That is sufficient to identify the product in my judgment in every case.

Nor is the patent only for a degree of purity, and therefore not for a new 'composition of matter.' As I have already shown, it does not include a salt, and no one had ever isolated a substance which was not in salt form, and which was anything like Takamine's. Indeed, Sadtler supposes it to exist as a natural salt, and that the base was an original production of Takamine's. That was a distinction not in degree, but in kind. But, even if it were merely an extracted product without change, there is no rule that such products are not patentable. Takamine was the first to make it available for any use by removing it from the other gland-tissue in which it was found, and, while it is of course possible logically to call this a purification of the principle, it became for every practical purpose a new thing commercially and therapeutically. That was a good ground for a patent. That the change here resulted in ample practical differences is fully proved. Everyone, not already saturated with scholastic distinctions, would recognize that Takamine's crystals were not merely the old dried glands in a purer state, nor would his opinion change if he learned that the crystals were obtained from the glands by a process of eliminating the inactive organic substances. The line between different substances and degrees of the same substance is to be drawn rather from the common usages of men than from nice considerations of dialectic.

. . .

## PATENTABLE SUBJECT MATTER

Whatever confusion the intricacy of the subject-matter causes, one fact stands out, which no one ought fairly to forget. Before Takamine's discovery the best experts were trying to get a practicable form of the active principle. The uses of the gland were so great that it became part of the usual therapy in the best form which was accessible. As soon as Takamine put out his discovery, other uses practically disappeared; by that I do not mean absolutely, but that the enormous proportion of use now is of Takamine's products. . . . All this ought to count greatly for the validity of the patent, and Takamine has a great start, so to speak, from such facts. It is true that he overstates the degree of stability of his acid solution without any preservative. Strictly it is not in that form fit for sale about in drug stores where it may be kept for long even in a stoppered bottle; but commercial or practical stability is a somewhat elastic term, and this is a case where he should be entitled to a lenient construction, for he has been author of a valuable invention and has succeeded where the most expert have failed.

### Context and Application

1. Which of the categories of ineligible subject matter were plausibly implicated by the claims in the '176 patent: laws of nature, natural phenomena, or abstract ideas?

2. How did the court evaluate the relationship between the argument that the claims were anticipated (i.e., not novel) and the argument that the claims were invalid because they "call for only an 'effect'"? Is the argument that "the patent [is] only for a degree of purity, and therefore not for a new 'composition of matter'" an argument that the patent is anticipated or an argument that it claims ineligible subject matter?

3. What is the "principle" to which the court refers? What about the "effect"?

4. Judge Hand concluded his opinion in *Parke-Davis* with the following commentary on some persistent questions about the allocation of authority among institutions in the patent system:

I cannot stop without calling attention to the extraordinary condition of the law which makes it possible for a man without any knowledge of even the rudiments of chemistry to pass upon such questions as these. The inordinate expense of time is the least of the resulting evils, for only a trained chemist is really capable of passing upon such facts, e.g., in this case the chemical character of Von Furth's so-called 'zinc compound,' or the presence of inactive organic substances. In Germany, where the national spirit eagerly seeks for all the assistance it can get from the whole range of human knowledge, they do quite differently. The court summons technical judges to whom technical questions are submitted and who can intelligently pass upon the issues without blindly groping among testimony

upon matters wholly out of their ken. How long we shall continue to blunder along without the aid of unpartisan and authoritative scientific assistance in the administration of justice, no one knows; but all fair persons not conventionalized by provincial legal habits of mind ought, I should think, unite to effect some such advance. . . .

189 F. at 115. Notwithstanding Judge Hand's pleas, the U.S. patent system continues to rely on non-technically trained trial judges and juries to resolve most factual issues in patent law. Do you think this is desirable or should we adopt something like the German system, in which patent cases are heard by judges who have technical expertise in the subject matter of the patents? What are some of the tradeoffs involved? *See* Sapna Kumar, *Judging Patents*, 62 WM. & MARY L. REV. 871 (2021) (describing the use of technically qualified judges in European patent courts and comparing it to the practice of relying on technically trained experts to advise U.S. courts). At the appellate level, the U.S. patent system now has a specialized court, the Federal Circuit, that hears appeals in patent cases (as well as a few other designated kinds of cases). While many of the judges on that court have some kind of formal education in a scientific or technical field, not all do. Should they? Keep in mind the allocation of authority between trial and appellate courts on matters of fact and matters of law. Finally, how does Judge Hand's closing lament compare to Justice Scalia's concurrence in *Myriad*?

5. For an analysis of the role that *Parke-Davis* played in the then-nascent embrace of patents by the pharmaceutical industry, as well as its more recent impact on gene patents, *see* Christopher Beauchamp, *Patenting Nature: A Problem of History*, 16 STAN. TECH. L. REV. 257 (2013).

*Funk Bros. Seed Co. v. Kalo Inoculant Co.*  
333 U.S. 127 (1948)

Mr. Justice DOUGLAS delivered the opinion of the Court.

This is a patent infringement suit brought by respondent. The charge of infringement is limited to certain product claims of Patent No. 2,200,532 issued to Bond on May 14, 1940.<sup>1</sup>

<sup>1</sup> The product claims in suit are 1, 3, 4, 5, 6, 7, 8, 13, and 14. Claim 4 is illustrative of the invention which is challenged. It reads as follows: "An inoculant for leguminous plants comprising a plurality of selected mutually non-inhibitive strains of different species of bacteria of the genus *Rhizobium*, said strains being unaffected by each other in respect to their ability to fix nitrogen in the leguminous plant for which they are specific."

. . . The question of validity is the only question presented by this petition for certiorari.

Through some mysterious process leguminous plants are able to take nitrogen from the air and fix it in the plant for conversion to organic nitrogenous compounds. The ability of these plants to fix nitrogen from the air depends on the presence of bacteria of the genus *Rhizobium* which infect the roots of the plant and form nodules on them. These root-nodule bacteria of the genus *Rhizobium* fall into at least six species. No one species will infect the roots of all species of leguminous plants. But each will infect well-defined groups of those plants. Each species of root-nodule bacteria is made up of distinct strains which vary in efficiency. Methods of selecting the strong strains and of producing a bacterial culture from them have long been known. The bacteria produced by the laboratory methods of culture are placed in a powder or liquid base and packaged for sale to and use by agriculturists in the inoculation of the seeds of leguminous plants. This also has long been well known.

It was the general practice, prior to the Bond patent, to manufacture and sell inoculants containing only one species of root-nodule bacteria. The inoculant could therefore be used successfully only in plants of the particular cross-inoculation group corresponding to this species. Thus if a farmer had crops of clover, alfalfa, and soy beans he would have to use three separate inoculants. There had been a few mixed cultures for field legumes. But they had proved generally unsatisfactory because the different species of the *Rhizobia* bacteria produced an inhibitory effect on each other when mixed in a common base, with the result that their efficiency was reduced. Hence it had been assumed that the different species were mutually inhibitive. Bond discovered that there are strains of each species of root-nodule bacteria which do not exert a mutually inhibitive effect on each other. He also ascertained that those mutually non-inhibitive strains can, by certain methods of selection and testing, be isolated and used in mixed cultures. Thus he provided a mixed culture of *Rhizobia* capable of inoculating the seeds of plants belonging to several cross-inoculation groups. It is the product claims which disclose that mixed culture that the Circuit Court of Appeals had held valid.

We do not have presented the question whether the methods of selecting and testing the non-inhibitive strains are patentable. We have here only product claims. Bond does not create state of inhibition or of non-inhibition in the bacteria. Their qualities are the work of nature. Those qualities are of course not patentable. For patents cannot issue for the discovery of the phenomena of nature. See *Le Roy v. Tatham*, 14 How. 156, 175. The qualities of these bacteria, like the heat of the sun, electricity, or the qualities of metals, are part of the storehouse of knowledge of all men. They are manifestations of laws of nature, free to all men and reserved exclusively to none. He who discovers a hitherto unknown phenomenon of nature has no claim to a monopoly of it which the law recognizes. If there is to be invention from such a discovery, it must come from the application of the law of

nature to a new and useful end. The Circuit Court of Appeals thought that Bond did much more than discover a law of nature, since he made an new and different composition of non-inhibitive strains which contributed utility and economy to the manufacture and distribution of commercial inoculants. But we think that that aggregation of species fell short of invention within the meaning of the patent statutes.

Discovery of the fact that certain strains of each species of these bacteria can be mixed without harmful effect to the properties of either is a discovery of their qualities of non-inhibition. It is no more than the discovery of some of the handiwork of nature and hence is not patentable. The aggregation of select strains of the several species into one product is an application of that newly-discovered natural principle. But however ingenious the discovery of that natural principle may have been, the application of it is hardly more than an advance in the packaging of the inoculants. Each of the species of root-nodule bacteria contained in the package infects the same group of leguminous plants which it always infected. No species acquires a different use. The combination of species produces no new bacteria, no change in the six species of bacteria, and no enlargement of the range of their utility. Each species has the same effect it always had. The bacteria perform in their natural way. Their use in combination does not improve in any way their natural functioning. They serve the ends nature originally provided and act quite independently of any effort of the patentee.

There is, of course, an advantage in the combination. The farmer need not buy six different packages for six different crops. He can buy one package and use it for any or all of his crops of leguminous plants. And, as respondent says, the packages of mixed inoculants also hold advantages for the dealers and manufacturers by reducing inventory problems and the like. But a product must be more than new and useful to be patented; it must also satisfy the requirements of invention or discovery. *Cuno Engineering Corp. v. Automatic Devices Corp.*, 314 U.S. 84, 90, 91 (1941). The application of this newly-discovered natural principle to the problem of packaging of inoculants may well have been an important commercial advance. But once nature's secret of the non-inhibitive quality of certain strains of the species of *Rhizobium* was discovered, the state of the art made the production of a mixed inoculant a simple step. Even though it may have been the product of skill, it certainly was not the product of invention. There is no way in which we could call it such unless we borrowed invention from the discovery of the natural principle itself. That is to say, there is no invention here unless the discovery that certain strains of the several species of these bacteria are non-inhibitive and may thus be safely mixed is invention. But we cannot so hold without allowing a patent to issue on one of the ancient secrets of nature now disclosed. All that remains, therefore, are advantages of the mixed inoculants themselves. They are not enough.

. . . Reversed.



## PATENTABLE SUBJECT MATTER

Mr. Justice FRANKFURTER, concurring.

My understanding of Bond's contribution is that prior to his attempts, packages of mixed cultures of inoculants presumably applicable to two or more different kinds of legumes had from time to time been prepared, but had met with indifferent success. The reasons for failure were not understood, but the authorities had concluded that in general pure culture inoculants were alone reliable because mixtures were ineffective due to the mutual inhibition of the combined strains of bacteria. Bond concluded that there might be special strains which lacked this mutual inhibition, or were at all events mutually compatible. Using techniques that had previously been developed to test efficiency in promoting nitrogen fixation of various bacterial strains, Bond tested such efficiency of various mixtures of strains. He confirmed his notion that some strains were mutually compatible . . . .

If this is a correct analysis of Bond's endeavors two different claims of originality are involved: (1) the idea that there are compatible strains, and (2) the experimental demonstration that there were in fact some compatible strains. . . . The strains by which Bond secured compatibility are not identified and are identifiable only by their compatibility.

Unless I misconceive the record, Bond makes no claim that Funk Brothers used the same combination of strains that he had found mutually compatible. He appears to claim that since he was the originator of the idea that there might be mutually compatible strains and had practically demonstrated that some such strains exist, everyone else is forbidden to use a combination of strains whether they are or are not identical with the combinations that Bond selected and packaged together. . . .

The consequences of such a conclusion call for its rejection. . . .

It only confuses the issue, however, to introduce such terms as "the work of nature" and the "laws of nature." For these are vague and malleable terms infected with too much ambiguity and equivocation. Everything that happens may be deemed "the work of nature," and any patentable composite exemplifies in its properties "the laws of nature." Arguments drawn from such terms for ascertaining patentability could fairly be employed to challenge almost every patent. On the other hand, the suggestion that "if there is to be invention from such a discovery, it must come from the application of the law of nature to a new and useful end" may readily validate Bond's claim. Nor can it be contended that there was no invention because the composite has no new properties other than its ingredients in isolation. Bond's mixture does in fact have the new property of multi-service applicability. Multi-purpose tools, multivalent vaccines, vitamin complex composites, are examples of complexes whose sole new property is the conjunction of the properties of their components. Surely the Court does not mean unwittingly to pass on

the patentability of such products by formulating criteria by which future issues of patentability may be prejudged. In finding Bond’s patent invalid I have tried to avoid a formulation which, while it would in fact justify Bond’s patent, would lay the basis for denying patentability to a large area within existing patent legislation.

### Context and Application

1. Although the Court has cited earlier decisions for the “inventive application” analysis, Jeffrey Lefstin argues that the “true origin of inventive application as a test for patent eligibility was Justice Douglas’s opinion in *Funk Brothers*.” Jeffrey A. Lefstin, *Inventive Application: A History*, 67 FLA. L. REV. 565, 624 (2015). Starting with a historical analysis of the early hot-blast cases, Lefstin concludes that *Funk Brothers* radically altered the law of patent eligibility by demanding that, when an inventor discovers a law of nature or natural phenomena, the patent must claim not merely “a *practical application* of the inventor’s discovery,” but instead “an *inventive application*” of that discovery. This heightened requirement prevented patents on straightforward applications of even remarkable discoveries. *Id.* at 628-31.

2. *Funk Brothers* was also the first case in which the Court clearly articulated “laws of nature” and “natural phenomena” as distinct categories of prohibited subject matter. But what exactly is a law of nature or natural phenomenon? The boundaries between the “manmade” and “natural” worlds are not always sharply defined. See Jacob S. Sherkow, *The Natural Complexity of Patent Eligibility*, 99 IOWA L. REV. 1137 (2014) (urging more reliance on scientific and philosophical perspectives, especially those associated with the theory of natural complexity, to define “laws of nature” and “natural phenomena”).



Developments in computers, software, and related technologies have forced the patent system to consider claims with more attenuated connections to the material world. Two cases in particular, *Parker v. Flook* and *Diamond v. Diehr*, have become touchstones for navigating the waters between ineligible abstract ideas and eligible inventions. As you read these cases, consider how—if at all—you might be able to reconcile them.

*Parker v. Flook*  
437 U.S. 584 (1978)

Mr. Justice STEVENS delivered the opinion of the Court.

Respondent applied for a patent on a “Method for Updating Alarm Limits.” The only novel feature of the method is a mathematical formula. In *Gottschalk v. Benson*, 409 U.S. 63 (1972), we held that the discovery of a novel and useful mathematical formula may not be patented. The question in this case is whether the identification of a limited category of useful, though conventional, post-solution applications of such a formula makes respondent’s method eligible for patent protection.

I

An “alarm limit” is a number. During catalytic conversion processes, operating conditions such as temperature, pressure, and flow rates are constantly monitored. When any of these “process variables” exceeds a predetermined “alarm limit,” an alarm may signal the presence of an abnormal condition indicating either inefficiency or perhaps danger. Fixed alarm limits may be appropriate for a steady operation, but during transient operating situations, such as start-up, it may be necessary to “update” the alarm limits periodically.

Respondent’s patent application describes a method of updating alarm limits. In essence, the method consists of three steps: an initial step which merely measures the present value of the process variable (*e.g.*, the temperature); an intermediate step which uses an algorithm to calculate an updated alarm-limit value; and a final step in which the actual alarm limit is adjusted to the updated value. The only difference between the conventional methods of changing alarm limits and that described in respondent’s application rests in the second step—the mathematical algorithm or formula. . . .

The patent application does not purport to explain how to select the appropriate margin of safety, the weighting factor, or any of the other variables. Nor does it purport to contain any disclosure relating to the chemical processes at work, the monitoring of process variables, or the means of setting off an alarm or adjusting an alarm system. All that it provides is a formula for computing an updated alarm limit. Although the computations can be made by pencil and paper calculations, the abstract of disclosure makes it clear that the formula is primarily useful for computerized calculations producing automatic adjustments in alarm settings.

The patent claims cover any use of respondent’s formula for updating the value of an alarm limit on any process variable involved in a process comprising the catalytic chemical conversion of hydrocarbons. Since there are numerous processes of that kind in the petrochemical and oil-refining industries, the claims cover a broad range of potential

uses of the method. They do not, however, cover every conceivable application of the formula.

### III

This case turns entirely on the proper construction of § 101 of the Patent Act, which describes the subject matter that is eligible for patent protection. It does not involve the familiar issues of novelty and obviousness that routinely arise under §§ 102 and 103 when the validity of a patent is challenged. For the purpose of our analysis, we assume that respondent's formula is novel and useful and that he discovered it. We also assume . . . that the formula is the only novel feature of respondent's method. The question is whether the discovery of this feature makes an otherwise conventional method eligible for patent protection.

The plain language of § 101 does not answer the question. It is true, as respondent argues, that his method is a "process" in the ordinary sense of the word. But that was also true of the algorithm, which described a method for converting binary-coded decimal numerals into pure binary numerals, that was involved in *Gottschalk v. Benson*. The holding that the discovery of that method could not be patented as a "process" forecloses a purely literal reading of § 101. Reasoning that an algorithm, or mathematical formula, is like a law of nature, *Benson* applied the established rule that a law of nature cannot be the subject of a patent. Quoting from earlier cases, we said:

"A principle, in the abstract, is a fundamental truth; an original cause; a motive; these cannot be patented, as no one can claim in either of them an exclusive right." *Le Roy v. Tatham*, 14 How. 156, 175 (1852). Phenomena of nature, though just discovered, mental processes, and abstract intellectual concepts are not patentable, as they are the basic tools of scientific and technological work.

The line between a patentable "process" and an unpatentable "principle" is not always clear. Both are "conceptions of the mind, seen only by their effects when being executed or performed." In *Benson* we concluded that the process application in fact sought to patent an idea, noting that

the mathematical formula involved here has no substantial practical application except in connection with a digital computer, which means that if the judgment below is affirmed, the patent would wholly pre-empt the mathematical formula and in practical effect would be a patent on the algorithm itself.

Respondent correctly points out that this language does not apply to his claims. He does not seek to "wholly preempt the mathematical formula," since there are uses of his formula outside the petrochemical and oil-refining industries that remain in the public domain. And he argues that the presence of specific "post-solution" activity—the

## PATENTABLE SUBJECT MATTER

adjustment of the alarm limit to the figure computed according to the formula—distinguishes this case from *Benson* and makes his process patentable. We cannot agree.

The notion that post-solution activity, no matter how conventional or obvious in itself, can transform an unpatentable principle into a patentable process exalts form over substance. A competent draftsman could attach some form of post-solution activity to almost any mathematical formula; the Pythagorean theorem would not have been patentable, or partially patentable, because a patent application contained a final step indicating that the formula, when solved, could be usefully applied to existing surveying techniques. . . .

Yet it is equally clear that a process is not unpatentable simply because it contains a law of nature or a mathematical algorithm.<sup>12</sup>

<sup>12</sup> In *Eibel Process Co.*, the Court upheld a patent on an improvement on a papermaking machine that made use of the law of gravity to enhance the flow of the product. The patentee, of course, did not claim to have discovered the force of gravity, but that force was an element in his novel conception. *Tilghman v. Proctor* involved a process claim for “the manufacturing of fat acids and glycerine from fatty bodies.” The Court distinguished the process from the principle involved as follows: “The claim of the patent is not for a mere principle. The chemical principle or scientific fact upon which it is founded is, that the elements of neutral fat require to be severally united with an atomic equivalent of water in order to separate from each other and become free. This chemical fact was not discovered by Tilghman. He only claims to have invented a particular mode of bringing about the desired chemical union between the fatty elements and water.”

For instance, in *Mackay Radio & Telegraph Co. v. Radio Corp. of America*, 306 U.S. 86, the applicant sought a patent on a directional antenna system in which the wire arrangement was determined by the logical application of a mathematical formula. . . . Mr. Justice Stone, writing for the Court, explained:

While a scientific truth, or the mathematical expression of it, is not patentable invention, a novel and useful structure created with the aid of knowledge of scientific truth may be.

*Funk Bros. Seed Co. v. Kalo Co.*, 333 U.S. 127, 130, expresses a similar approach:

He who discovers a hitherto unknown phenomenon of nature has no claim to a monopoly of it which the law recognizes. If there is to be invention from such a discovery, it must come from the application of the law of nature to a new and useful end.

*Mackay Radio* and *Funk Bros.* point to the proper analysis for this case: The process itself, not merely the mathematical algorithm, must be new and useful. Indeed, the novelty of the mathematical algorithm is not a determining factor at all. Whether the algorithm was in fact known or unknown at the time of the claimed invention, as one of the “basic tools of scientific and technological work,” it is treated as though it were a familiar part of the prior art.

This is also the teaching of our landmark decision in *O’Reilly v. Morse*, 15 How. 62. In that case the Court rejected Samuel Morse’s broad claim covering any use of electromagnetism for printing intelligible signs, characters, or letters at a distance. In reviewing earlier cases applying the rule that a scientific principle cannot be patented, the Court placed particular emphasis on the English case of *Neilson v. Harford*, Web. Pat. Cases 295, 371 (1844), which involved the circulation of heated air in a furnace system to increase its efficiency. The English court rejected the argument that the patent merely covered the principle that furnace temperature could be increased by injecting hot air, instead of cold into the furnace. That court’s explanation of its decision was relied on by this Court in *Morse*:

“It is very difficult to distinguish the Neilson patent from the specification of a patent for a principle, and this at first created in the minds of the court much difficulty; but after full consideration, we think that the plaintiff does not merely claim a principle, but a machine, embodying a principle, and a very valuable one. *We think the case must be considered as if the principle being well known, the plaintiff had first invented a mode of applying it . . .*”

We think this case must also be considered as if the principle or mathematical formula were well known.

Respondent argues that this approach improperly imports into § 101 the considerations of “inventiveness” which are the proper concerns of §§ 102 and 103. This argument is based on two fundamental misconceptions.

First, respondent incorrectly assumes that if a process application implements a principle in some specific fashion, it automatically falls within the patentable subject matter of § 101 and the substantive patentability of the particular process can then be determined by the conditions of §§ 102 and 103. This assumption is based on respondent’s narrow reading of *Benson*, and is as untenable in the context of § 101 as it is in the context of that case. It would make the determination of patentable subject matter depend simply on the draftsman’s art and would ill serve the principles underlying the prohibition against patents for “ideas” or phenomena of nature. The rule that the discovery of a law of nature cannot be patented rests, not on the notion that natural phenomena are not

processes, but rather on the more fundamental understanding that they are not the kind of “discoveries” that the statute was enacted to protect.<sup>15</sup>

<sup>15</sup> The underlying notion is that a scientific principle, such as that expressed in respondent’s algorithm, reveals a relationship that has always existed. “An example of such a discovery of a scientific principle was Newton’s formulation of the law of universal gravitation, relating the force of attraction between two bodies,  $F$ , to their masses,  $m$  and  $m'$ , and the square of the distance,  $d$ , between their centers, according to the equation  $F=mm'/d^2$ . But this relationship always existed—even before Newton announced his celebrated law. Such ‘mere’ recognition of a theretofore existing phenomenon or relationship carries with it no rights to exclude others from its enjoyment. . . . Patentable subject matter must be new (novel); not merely heretofore unknown. There is a very compelling reason for this rule. The reason is founded upon the proposition that in granting patent rights, the public must not be deprived of any rights that it theretofore freely enjoyed.” P. ROSENBERG, PATENT LAW FUNDAMENTALS, § 4, p. 13 (1975).

The obligation to determine what type of discovery is sought to be patented must precede the determination of whether that discovery is, in fact, new or obvious.

Second, respondent assumes that the fatal objection to his application is the fact that one of its components—the mathematical formula—consists of unpatentable subject matter. In countering this supposed objection, respondent relies on opinions by the Court of Customs and Patent Appeals which reject the notion “that a claim may be dissected, the claim components searched in the prior art, and, if the only component found novel is outside the statutory classes of invention, the claim may be rejected under 35 U.S.C. § 101.” Our approach to respondent’s application is, however, not at all inconsistent with the view that a patent claim must be considered as a whole. Respondent’s process is unpatentable under § 101, not because it contains a mathematical algorithm as one component, but because once that algorithm is assumed to be within the prior art, the application, considered as a whole, contains no patentable invention. Even though a phenomenon of nature or mathematical formula may be well known, an inventive application of the principle may be patented. Conversely, the discovery of such a phenomenon cannot support a patent unless there is some other inventive concept in its application.

Here it is absolutely clear that respondent’s application contains no claim of patentable invention. The chemical processes involved in catalytic conversion of hydrocarbons are well known, as are the practice of monitoring the chemical process variables, the use of alarm limits to trigger alarms, the notion that alarm limit values must be recomputed and readjusted, and the use of computers for “automatic monitoring-alarming.” Respondent’s application simply provides a new and presumably better method for calculating alarm

limit values. If we assume that that method was also known, as we must under the reasoning in *Morse*, then respondent's claim is, in effect, comparable to a claim that the formula  $2\pi r$  can be usefully applied in determining the circumference of a wheel. . . .

To a large extent our conclusion is based on reasoning derived from opinions written before the modern business of developing programs for computers was conceived. The youth of the industry may explain the complete absence of precedent supporting patentability. Neither the dearth of precedent, nor this decision, should therefore be interpreted as reflecting a judgment that patent protection of certain novel and useful computer programs will not promote the progress of science and the useful arts, or that such protection is undesirable as a matter of policy. Difficult questions of policy concerning the kinds of programs that may be appropriate for patent protection and the form and duration of such protection can be answered by Congress on the basis of current empirical data not equally available to this tribunal.

. . .

Reversed.

Mr. Justice STEWART, with whom THE CHIEF JUSTICE and Mr. Justice REHNQUIST join, dissenting.

It is a commonplace that laws of nature, physical phenomena, and abstract ideas are not patentable subject matter. A patent could not issue, in other words, on the law of gravity, or the multiplication tables, or the phenomena of magnetism, or the fact that water at sea level boils at 100 degrees centigrade and freezes at zero—even though newly discovered. *Le Roy v. Tatham*, 14 How. 156, 175; *O'Reilly v. Morse*, 15 How. 62, 112–121; *Rubber-Tip Pencil Co. v. Howard*, 20 Wall. 498, 507; *Tilghman v. Proctor*, 102 U.S. 707; *Mackay Radio & Telegraph Co. v. Radio Corp. of America*, 306 U.S. 86, 94; *Funk Bros. Seed Co. v. Kalo Co.*, 333 U.S. 127, 130.

The recent case of *Gottschalk v. Benson*, 409 U.S. 63, stands for no more than this long-established principle, which the Court there stated in the following words: "Phenomena of nature, though just discovered, mental processes, and abstract intellectual concepts are not patentable, as they are the basic tools of scientific and technological work." In *Benson* the Court held unpatentable claims for an algorithm that "were not limited to any particular art or technology, to any particular apparatus or machinery, or to any particular end use." A patent on such claims, the Court said, "would wholly pre-empt the mathematical formula and in practical effect would be a patent on the algorithm itself."

The present case is a far different one. The issue here is whether a claimed process loses its status of subject-matter patentability simply because *one step* in the process would not be patentable subject matter if considered in isolation. The Court of Customs and



## PATENTABLE SUBJECT MATTER

Patent Appeals held that the process is patentable subject matter, *Benson* being inapplicable since “the present claims do not preempt the formula or algorithm contained therein, because solution of the algorithm, per se, would not infringe the claims.”

That decision seems to me wholly in conformity with basic principles of patent law. Indeed, I suppose that thousands of processes and combinations have been patented that contained one or more steps or elements that themselves would have been unpatentable subject matter. *Eibel Process Co. v. Minnesota & Ontario Paper Co.*, 261 U.S. 45, is a case in point. There the Court upheld the validity of an improvement patent that made use of the law of gravity, which by itself was clearly unpatentable.

The Court today . . . strikes what seems to me an equally damaging blow at basic principles of patent law by importing into its inquiry under 35 U.S.C. § 101 the criteria of novelty and inventiveness. Section 101 is concerned only with subject-matter patentability. Whether a patent will actually *issue* depends upon the criteria of §§ 102 and 103, which include novelty and inventiveness, among many others. It may well be that under the criteria of §§ 102 and 103 no patent should issue on the process claimed in this case . . . . But in my view the claimed process clearly meets the standards of subject-matter patentability of § 101.

. . . Accordingly, I would affirm the judgment before us.

*Diamond v. Diehr*  
450 U.S. 175 (1981)

Justice REHNQUIST delivered the opinion of the Court.

We granted certiorari to determine whether a process for curing synthetic rubber which includes in several of its steps the use of a mathematical formula and a programmed digital computer is patentable subject matter under 35 U.S.C. § 101.

### I

The patent application at issue was filed by the respondents on August 6, 1975. The claimed invention is a process for molding raw, uncured synthetic rubber into cured precision products. The process uses a mold for precisely shaping the uncured material under heat and pressure and then curing the synthetic rubber in the mold so that the product will retain its shape and be functionally operative after the molding is completed.

Respondents claim that their process ensures the production of molded articles which are properly cured. Achieving the perfect cure depends upon several factors including the thickness of the article to be molded, the temperature of the molding process, and the amount of time that the article is allowed to remain in the press. It is possible using well-

known time, temperature, and cure relationships to calculate by means of the Arrhenius equation when to open the press and remove the cured product. Nonetheless, according to the respondents, the industry has not been able to obtain uniformly accurate cures because the temperature of the molding press could not be precisely measured, thus making it difficult to do the necessary computations to determine cure time.

Because the temperature *inside* the press has heretofore been viewed as an uncontrollable variable, the conventional industry practice has been to calculate the cure time as the shortest time in which all parts of the product will definitely be cured, assuming a reasonable amount of mold-opening time during loading and unloading. But the shortcoming of this practice is that operating with an uncontrollable variable inevitably led in some instances to overestimating the mold-opening time and overcuring the rubber, and in other instances to underestimating that time and undercuring the product.

Respondents characterize their contribution to the art to reside in the process of constantly measuring the actual temperature inside the mold. These temperature measurements are then automatically fed into a computer which repeatedly recalculates the cure time by use of the Arrhenius equation. When the recalculated time equals the actual time that has elapsed since the press was closed, the computer signals a device to open the press. According to the respondents, the continuous measuring of the temperature inside the mold cavity, the feeding of this information to a digital computer which constantly recalculates the cure time, and the signaling by the computer to open the press, are all new in the art.

The patent examiner rejected the respondents' claims on the sole ground that they were drawn to nonstatutory subject matter under 35 U.S.C. § 101. . . .

## II

Last Term in *Diamond v. Chakrabarty*, 447 U.S. 303 (1980), this Court discussed the historical purposes of the patent laws and in particular 35 U.S.C. § 101. As in *Chakrabarty*, we must here construe 35 U.S.C. § 101 which provides:

Whoever, invents or discovers any new and useful process, machine manufacture, or composition of matter, or any new and useful improvement thereof, may obtain a patent therefor, subject to the conditions and requirements of this title.

In cases of statutory construction, we begin with the language of the statute. Unless otherwise defined, "words will be interpreted as taking their ordinary, contemporary, common meaning," and, in dealing with the patent laws, we have more than once cautioned that "courts should not read into the patent laws limitations and conditions which the legislature has not expressed."

## PATENTABLE SUBJECT MATTER

The Patent Act of 1793 defined statutory subject matter as “any new and useful art, machine, manufacture or composition of matter, or any new or useful improvement thereof.” Not until the patent laws were recodified in 1952 did Congress replace the word “art” with the word “process.” It is that latter word which we confront today, and in order to determine its meaning we may not be unmindful of the Committee Reports accompanying the 1952 Act which inform us that Congress intended statutory subject matter to “include anything under the sun that is made by man.”

Although the term “process” was not added to 35 U.S.C. § 101 until 1952 a process has historically enjoyed patent protection because it was considered a form of “art” as that term was used in the 1793 Act. . . .

Analysis of the eligibility of a claim of patent protection for a “process” did not change with the addition of that term to § 101. Recently, in *Gottschalk v. Benson*, 409 U.S. 63 (1972), we . . . added: “Transformation and reduction of an article ‘to a different state or thing’ is the clue to the patentability of a process claim that does not include particular machines.”

Analyzing respondents’ claims according to the above statements from our cases, we think that a physical and chemical process for molding precision synthetic rubber products falls within the § 101 categories of possibly patentable subject matter. That respondents’ claims involve the transformation of an article, in this case raw, uncured synthetic rubber, into a different state or thing cannot be disputed. The respondents’ claims describe in detail a step-by-step method for accomplishing such, beginning with the loading of a mold with raw, uncured rubber and ending with the eventual opening of the press at the conclusion of the cure. Industrial processes such as this are the types which have historically been eligible to receive the protection of our patent laws.

### III

Our conclusion regarding respondents’ claims is not altered by the fact that in several steps of the process a mathematical equation and a programmed digital computer are used. This Court has undoubtedly recognized limits to § 101 and every discovery is not embraced within the statutory terms. Excluded from such patent protection are laws of nature, natural phenomena, and abstract ideas. See *Parker v. Flook*, 437 U.S. 584 (1978); *Gottschalk v. Benson*, *supra*, at 67; *Funk Bros. Seed Co. v. Kalo Inoculant Co.*, 333 U.S. 127, 130, (1948). “An idea of itself is not patentable,” *Rubber-Tip Pencil Co. v. Howard*, 20 Wall. 498, 507 (1874). “A principle, in the abstract, is a fundamental truth; an original cause; a motive; these cannot be patented, as no one can claim in either of them an exclusive right.” *Le Roy v. Tatham*, 14 How. 156, 175 (1853). Only last Term, we explained:

A new mineral discovered in the earth or a new plant found in the wild is not patentable subject matter. Likewise, Einstein could not patent his celebrated law

that  $E = mc^2$ ; nor could Newton have patented the law of gravity. Such discoveries are “manifestations of . . . nature, free to all men and reserved exclusively to none.”

*Diamond v. Chakrabarty*, 447 U.S., at 309.

Our recent holdings in *Gottschalk v. Benson*, and *Parker v. Flook*, both of which are computer-related, stand for no more than these long-established principles. In *Benson*, we held unpatentable claims for an algorithm used to convert binary code decimal numbers to equivalent pure binary numbers. The sole practical application of the algorithm was in connection with the programming of a general purpose digital computer. We defined “algorithm” as a “procedure for solving a given type of mathematical problem,” and we concluded that such an algorithm, or mathematical formula, is like a law of nature, which cannot be the subject of a patent.

*Parker v. Flook*, presented a similar situation. The claims were drawn to a method for computing an “alarm limit.” An “alarm limit” is simply a number and the Court concluded that the application sought to protect a formula for computing this number. Using this formula, the updated alarm limit could be calculated if several other variables were known. The application, however, did not purport to explain how these other variables were to be determined, nor did it purport “to contain any disclosure relating to the chemical processes at work, the monitoring of process variables, or the means of setting off an alarm or adjusting an alarm system. All that it provides is a formula for computing an updated alarm limit.”

In contrast, the respondents here do not seek to patent a mathematical formula. Instead, they seek patent protection for a process of curing synthetic rubber. Their process admittedly employs a well-known mathematical equation, but they do not seek to preempt the use of that equation. Rather, they seek only to foreclose from others the use of that equation in conjunction with all of the other steps in their claimed process. These include installing rubber in a press, closing the mold, constantly determining the temperature of the mold, constantly recalculating the appropriate cure time through the use of the formula and a digital computer, and automatically opening the press at the proper time. Obviously, one does not need a “computer” to cure natural or synthetic rubber, but if the computer use incorporated in the process patent significantly lessens the possibility of “overcuring” or “undercuring,” the process as a whole does not thereby become unpatentable subject matter.

Our earlier opinions lend support to our present conclusion that a claim drawn to subject matter otherwise statutory does not become nonstatutory simply because it uses a mathematical formula, computer program, or digital computer. . . . It is now commonplace that an *application* of a law of nature or mathematical formula to a known structure or process may well be deserving of patent protection. *See, e. g., Funk Bros. Seed*

## PATENTABLE SUBJECT MATTER

*Co. v. Kalo Inoculant Co.*, 333 U.S. 127 (1948); *Eibel Process Co. v. Minnesota & Ontario Paper Co.*, 261 U.S. 45 (1923); *Cochrane v. Deener*, 94 U.S. 780 (1877); *O'Reilly v. Morse*, 15 How. 62 (1854); and *Le Roy v. Tatham*, 14 How. 156 (1853). As Justice Stone explained four decades ago: "While a scientific truth, or the mathematical expression of it, is not a patentable invention, a novel and useful structure created with the aid of knowledge of scientific truth may be." *Mackay Radio & Telegraph Co. v. Radio of America*, 306 U.S. 86, 94 (1939).

We think this statement in *Mackay* takes us a long way toward the correct answer in this case. Arrhenius' equation is not patentable in isolation, but when a process for curing rubber is devised which incorporates in it a more efficient solution of the equation, that process is at the very least not barred at the threshold by § 101.

In determining the eligibility of respondents' claimed process for patent protection under § 101, their claims must be considered as a whole. It is inappropriate to dissect the claims into old and new elements and then to ignore the presence of the old elements in the analysis. This is particularly true in a process claim because a new combination of steps in a process may be patentable even though all the constituents of the combination were well known and in common use before the combination was made. The "novelty" of any element or steps in a process, or even of the process itself, is of no relevance in determining whether the subject matter of a claim falls within the § 101 categories of possibly patentable subject matter.<sup>12</sup>

<sup>12</sup> It is argued that the procedure of dissecting a claim into old and new elements is mandated by our decision in *Flook* which noted that a mathematical algorithm must be assumed to be within the "prior art." It is from this language that the petitioner premises his argument that if everything other than the algorithm is determined to be old in the art, then the claim cannot recite statutory subject matter. The fallacy in this argument is that we did not hold in *Flook* that the mathematical algorithm could not be considered at all when making the § 101 determination. To accept the analysis proffered by the petitioner would, if carried to its extreme, make all inventions unpatentable because all inventions can be reduced to underlying principles of nature which, once known, make their implementation obvious. . . .

It has been urged that novelty is an appropriate consideration under § 101. Presumably, this argument results from the language in § 101 referring to any "new and useful" process, machine, etc. Section 101, however, is a general statement of the type of subject matter that is eligible for patent protection "subject to the conditions and requirements of this title." Specific conditions for patentability follow and § 102 covers in detail the conditions relating to novelty. The question therefore of whether a particular invention is novel is "wholly apart from whether the invention falls into a category of

## CHAPTER 3

statutory subject matter.” The legislative history of the 1952 Patent Act is in accord with this reasoning. The Senate Report stated:

Section 101 sets forth the subject matter that can be patented, “subject to the conditions and requirements of this title.” The conditions under which a patent may be obtained follow, and *Section 102 covers the conditions relating to novelty*.

It is later stated in the same Report:

Section 102, in general, may be said to describe the statutory novelty required for patentability, and includes, in effect, an amplification and definition of “new” in section 101.

Finally, it is stated in the “Revision Notes”:

The corresponding section of the existing statute is split into two sections, section 101 relating to the subject matter for which patents may be obtained, and section 102 defining statutory novelty and stating other conditions for patentability.

In this case, it may later be determined that the respondents’ process is not deserving of patent protection because it fails to satisfy the statutory conditions of novelty under § 102 or nonobviousness under § 103. A rejection on either of these grounds does not affect the determination that respondents’ claims recited subject matter which was eligible for patent protection under § 101.

## IV

We have before us today only the question of whether respondents’ claims fall within the § 101 categories of possibly patentable subject matter. We view respondents’ claims as nothing more than a process for molding rubber products and not as an attempt to patent a mathematical formula. We recognize, of course, that when a claim recites a mathematical formula (or scientific principle or phenomenon of nature), an inquiry must be made into whether the claim is seeking patent protection for that formula in the abstract. A mathematical formula as such is not accorded the protection of our patent laws, *Gottschalk v. Benson*, and this principle cannot be circumvented by attempting to limit the use of the formula to a particular technological environment. *Parker v. Flook*. Similarly, insignificant post-solution activity will not transform an unpatentable principle into a patentable process.<sup>14</sup>

<sup>14</sup> Arguably, the claims in *Flook* did more than present a mathematical formula. The claims also solved the calculation in order to produce a new number or “alarm limit” and then replaced the old number with the number newly produced. The claims covered all uses of the formula in processes “comprising the catalytic chemical conversion of hydrocarbons.” There are numerous such processes in the petrochemical and oil refinery industries and the claims therefore covered a broad

## PATENTABLE SUBJECT MATTER

range of potential uses. The claims, however, did not cover every conceivable application of the formula. We rejected in *Flook* the argument that because all possible uses of the mathematical formula were not pre-empted, the claim should be eligible for patent protection. Our reasoning in *Flook* is in no way inconsistent with our reasoning here. A mathematical formula does not suddenly become patentable subject matter simply by having the applicant acquiesce to limiting the reach of the patent for the formula to a particular technological use. A mathematical formula in the abstract is nonstatutory subject matter regardless of whether the patent is intended to cover all uses of the formula or only limited uses. Similarly, a mathematical formula does not become patentable subject matter merely by including in the claim for the formula token postsolution activity such as the type claimed in *Flook*. We were careful to note in *Flook* that the patent application did not purport to explain how the variables used in the formula were to be selected, nor did the application contain any disclosure relating to chemical processes at work or the means of setting off an alarm or adjusting the alarm unit. All the application provided was a “formula for computing an updated alarm limit.”

To hold otherwise would allow a competent draftsman to evade the recognized limitations on the type of subject matter eligible for patent protection. On the other hand, when a claim containing a mathematical formula implements or applies that formula in a structure or process which, when considered as a whole, is performing a function which the patent laws were designed to protect (e.g., transforming or reducing an article to a different state or thing), then the claim satisfies the requirements of § 101. Because we do not view respondents’ claims as an attempt to patent a mathematical formula, but rather to be drawn to an industrial process for the molding of rubber products, we affirm the judgment of the Court of Customs and Patent Appeals.<sup>15</sup>

<sup>15</sup> The dissent’s analysis rises and falls on its characterization of respondents’ claims as presenting nothing more than “an improved method of calculating the time that the mold should remain closed during the curing process.” The dissent states that respondents claim only to have developed “a new method of programming a digital computer in order to calculate—promptly and repeatedly—the correct curing time in a familiar process.” Respondents’ claims, however, are not limited to the isolated step of “programming a digital computer.” Rather, respondents’ claims describe a process of curing rubber beginning with the loading of the mold and ending with the opening of the press and the production of a synthetic rubber product that has been perfectly cured—a result heretofore unknown in the art. The fact that one or more of the steps in respondents’ process may not, in isolation, be novel or independently eligible for

patent protection is irrelevant to the question of whether the claims as a whole recite subject matter *eligible* for patent protection under § 101. As we explained when discussing machine patents in *Deepsouth Packing Co. v. Laitram Corp.*, 406 U.S. 518 (1972): “The patents were warranted not by the novelty of their elements but by the novelty of the combination they represented. Invention was recognized because Laitram’s assignors combined ordinary elements in an extraordinary way—a novel union of old means was designed to achieve new ends. Thus, for both inventions the whole in some way exceeded the sum of its parts.”

It is so ordered.

Justice STEVENS, with whom Justice BRENNAN, Justice MARSHALL, and Justice BLACKMUN join, dissenting.

The starting point in the proper adjudication of patent litigation is an understanding of what the inventor claims to have discovered. The Court’s decision in this case rests on a misreading of the Diehr and Lutton patent application. Moreover, the Court has compounded its error by ignoring the critical distinction between the character of the subject matter that the inventor claims to be novel—the § 101 issue—and the question whether that subject matter is in fact novel—the § 102 issue.

## I

Before discussing the major flaws in the Court’s opinion, a word of history may be helpful. . . .

Prior to 1968, well-established principles of patent law probably would have prevented the issuance of a valid patent on almost any conceivable computer program. Under the “mental steps” doctrine, processes involving mental operations were considered unpatentable. The mental-steps doctrine was based upon the familiar principle that a scientific concept or mere idea cannot be the subject of a valid patent. The doctrine was regularly invoked to deny patents to inventions consisting primarily of mathematical formulae or methods of computation. It was also applied against patent claims in which a mental operation or mathematical computation was the sole novel element or inventive contribution; it was clear that patentability could not be predicated upon a mental step. Under the “function of a machine” doctrine, a process which amounted to nothing more than a description of the function of a machine was unpatentable. This doctrine had its origin in several 19th-century decisions of this Court, and it had been consistently followed thereafter by the lower federal courts. Finally, the definition of “process” announced by this Court in *Cochrane v. Deener*, 94 U.S. 780, 787–788 (1877), seemed to indicate that a patentable process must cause a physical transformation in the materials to which the process is applied.



...

In *Flook*, this Court clarified *Benson* in three significant respects. First, *Flook* held that the *Benson* rule of unpatentable subject matter was not limited, as the lower court believed, to claims which wholly pre-empted an algorithm or amounted to a patent on the algorithm itself. Second, the Court made it clear that an improved method of calculation, even when employed as part of a physical process, is not patentable subject matter under § 101. Finally, the Court explained the correct procedure for analyzing a patent claim employing a mathematical algorithm. Under this procedure, the algorithm is treated for § 101 purposes as though it were a familiar part of the prior art; the claim is then examined to determine whether it discloses “some other inventive concept.”<sup>22</sup>

<sup>22</sup> This form of claim analysis did not originate with *Flook*. Rather, the Court derived it from the landmark decision of *O’Reilly v. Morse*, 15 How. 62, 115 (1854). In addition, this analysis is functionally the same as the point-of-novelty analysis used in conjunction with the mental-steps doctrine. . . .

## II

[T]he starting point in the proper adjudication of patent litigation is an understanding of what the inventor claims to have discovered. . . .

In the first sentence of its opinion, the Court states the question presented as “whether a process for curing synthetic rubber . . . is patentable subject matter.” Of course, that question was effectively answered many years ago when Charles Goodyear obtained his patent on the vulcanization process. The patent application filed by Diehr and Lutton, however, teaches nothing about the chemistry of the synthetic rubber-curing process, nothing about the raw materials to be used in curing synthetic rubber, nothing about the equipment to be used in the process, and nothing about the significance or effect of any process variable such as temperature, curing time, particular compositions of material, or mold configurations. In short, Diehr and Lutton do not claim to have discovered anything new about the process for curing synthetic rubber.

As the Court reads the claims in the Diehr and Lutton patent application, the inventors’ discovery is a method of constantly measuring the actual temperature inside a rubber molding press. As I read the claims, their discovery is an improved method of calculating the time that the mold should remain closed during the curing process. If the Court’s reading of the claims were correct, I would agree that they disclose patentable subject matter. On the other hand, if the Court accepted my reading, I feel confident that the case would be decided differently.

There are three reasons why I cannot accept the Court’s conclusion that Diehr and Lutton claim to have discovered a new method of constantly measuring the temperature

inside a mold. First, there is not a word in the patent application that suggests that there is anything unusual about the temperature-reading devices used in this process—or indeed that any particular species of temperature-reading device should be used in it. Second, since devices for constantly measuring actual temperatures—on a back porch, for example—have been familiar articles for quite some time, I find it difficult to believe that a patent application filed in 1975 was premised on the notion that a “process of constantly measuring the actual temperature” had just been discovered. Finally, the Patent and Trademark Office Board of Appeals expressly found that “the only difference between the conventional methods of operating a molding press and that claimed in [the] application rests in those steps of the claims which relate to the calculation incident to the solution of the mathematical problem or formula used to control the mold heater and the automatic opening of the press.” . . .

A fair reading of the entire patent application, as well as the specific claims, makes it perfectly clear that what Diehr and Lutton claim to have discovered is a method of using a digital computer to determine the amount of time that a rubber molding press should remain closed during the synthetic rubber-curing process. There is no suggestion that there is anything novel in the instrumentation of the mold, in actuating a timer when the press is closed, or in automatically opening the press when the computed time expires. Nor does the application suggest that Diehr and Lutton have discovered anything about the temperatures in the mold or the amount of curing time that will produce the best cure. What they claim to have discovered, in essence, is a method of updating the original estimated curing time by repetitively recalculating that time pursuant to a well-known mathematical formula in response to variations in temperature within the mold. Their method of updating the curing time calculation is strikingly reminiscent of the method of updating alarm limits that Dale Flook sought to patent.

During the [*Flook*] conversion process, variables such as temperature, pressure, and flow rates were constantly monitored and fed into the computer; in this case, temperature in the mold is the variable that is monitored and fed into the computer. In *Flook*, the digital computer repetitively recalculated the “alarm limit”—a number that might signal the need to terminate or modify the catalytic conversion process; in this case, the digital computer repetitively recalculates the correct curing time—a number that signals the time when the synthetic rubber molding press should open.

The essence of the claimed discovery in both cases was an algorithm that could be programmed on a digital computer. In *Flook*, the algorithm made use of multiple process variables; in this case, it makes use of only one. In *Flook*, the algorithm was expressed in a newly developed mathematical formula; in this case, the algorithm makes use of a well-known mathematical formula. Manifestly, neither of these differences can explain today’s holding. . . .

## III

The Court misapplies *Parker v. Flook* because . . . it fails to understand or completely disregards the distinction between the subject matter of what the inventor *claims* to have discovered—the § 101 issue—and the question whether that claimed discovery is in fact novel—the § 102 issue. If there is not even a claim that anything constituting patentable subject matter has been discovered, there is no occasion to address the novelty issue. Or, as was true in *Flook*, if the only concept that the inventor claims to have discovered is not patentable subject matter, § 101 requires that the application be rejected without reaching any issue under § 102 . . . .

Proper analysis, therefore, must start with an understanding of what the inventor claims to have discovered—or phrased somewhat differently—what he considers his inventive concept to be. It seems clear to me that Diehr and Lutton claim to have developed a new method of programming a digital computer in order to calculate—promptly and repeatedly—the correct curing time in a familiar process. In the § 101 analysis, we must assume that the sequence of steps in this programming method is novel, unobvious, and useful. The threshold question of whether such a method is patentable subject matter remains.

If that method is regarded as an “algorithm” . . . and if no other inventive concept is disclosed in the patent application, the question must be answered in the negative. In both *Benson* and *Flook*, the parties apparently agreed that the inventor’s discovery was properly regarded as an algorithm; the holding that an algorithm was a “law of nature” that could not be patented therefore determined that those discoveries were not patentable processes within the meaning of § 101.

As the Court recognizes today, *Flook* also rejected the argument that patent protection was available if the inventor did not claim a monopoly on every conceivable use of the algorithm but instead limited his claims by describing a specific postsolution activity . . . . [T]he Court characterizes that postsolution activity as “insignificant,” or as merely “token” activity. As a practical matter however, the postsolution activity described in the *Flook* application was no less significant than the automatic opening of the curing mold involved in this case. For setting off an alarm limit at the appropriate time is surely as important to the safe and efficient operation of a catalytic conversion process as is actuating the mold-opening device in a synthetic rubber-curing process. In both cases, the post-solution activity is a significant part of the industrial process. But in neither case should that activity have any *legal* significance because it does not constitute a part of the inventive concept that the applicants claimed to have discovered.

. . .

## CHAPTER 3

Even the Court does not suggest that the computer program developed by Diehr and Lutton is a patentable discovery. Accordingly, if we treat the program as though it were a familiar part of the prior art—as well-established precedent requires—it is absolutely clear that their application contains no claim of patentable invention. Their application was therefore properly rejected under § 101 by the Patent Office and the Board of Appeals.

### IV

The broad question whether computer programs should be given patent protection involves policy considerations that this Court is not authorized to address. . . .

. . . Because invention claimed in the patent application at issue in this case makes no contribution to the art that is not entirely dependent upon the utilization of a computer in a familiar process, I would reverse. . . .

### Context and Application

1. *Flook* and *Diehr* have play an important role in the current patent eligibility framework. The Court in *Mayo* relied on the difference between these two cases to buttress its conclusion that the claim at issue was ineligible. See *Mayo Collaborative Services v. Prometheus Labs.*, 566 U.S. 66, 82 (2012) (“The claim before us presents a case for patentability that is weaker than the (patent-eligible) claim in *Diehr* and no stronger than the (unpatentable) claim in *Flook*.”). But there is considerable tension in how these cases evaluate the question of patent eligibility. See Bernard Chao, *Moderating Mayo*, 107 NW. U. L. REV. COLLOQUY 82, 89 (2012) (“*Flook* and *Diehr* are simply irreconcilable”). This tension arises in large part because the cases appear to disagree on whether it is appropriate to separately identify elements in a claim that are “old” from those that are “new,” and consider only the “new” elements in the eligibility analysis. As John Golden explains,

[*Diehr*] emphasizes the principle that, in an assessment of subject-matter eligibility, claims “must be considered as a whole,” it being “inappropriate to dissect the claims into old and new elements and then to ignore the presence of the old elements in the analysis.” At the same time, *Diehr* advocates an “anti-principle” that reveals some willingness to dissect claims: *Diehr* instructs that inclusion of “insignificant post-solution activity” into a claim “will not transform an unpatentable principle into a patentable process.” In support of this anti-principle, *Diehr* cites the Court’s 1978 opinion in *Parker v. Flook*, in which the opinion for the Court had suggested the possibility of at least partial dissection of claims into old and new elements for purposes of subject-matter eligibility analysis. In *Flook*, the Court rejected “the notion that post-solution activity, no matter how conventional

or obvious in itself, can transform an unpatentable principle into a patentable process,” saying that such an idea “exalts form over substance.”

John Golden, *Flook Says One Thing, Diehr Says Another: A Need for Housecleaning in the Law of Patentable Subject Matter*, 82 GEO. WASH. L. REV. 1765, 1781 (2014). One possible way to resolve this tension is to view *Flook* as covering “a relatively limited class [of cases involving claims to] essentially trivial combinations of excluded subject matter and conventional steps,” while viewing *Diehr* as standing for the proposition that claims are eligible so long as they (1) cover solutions to “technological problem[s]” or (2) “improve[] an existing technological process.” *Id.* at 1788, 1792.

The Court also characterizes *Flook* and *Diehr* as Step Two cases; that is, it has used them to illustrate the difference between claims that incorporate an inventive concept and claims that do not. Another way to resolve the tension between the cases is to view them as Step One cases. If we apply a central claiming approach to understanding the claims, we can distinguish *Flook* from *Diehr* on the grounds that the patent in *Flook* characterized the inventor’s contribution as encompassing ineligible subject matter (the novel algorithm for recalculating alarm limits) while the patent in *Diehr* characterized the inventor’s contribution as encompassing eligible subject matter (the improved method of molding rubber). From this perspective, the claim in *Flook* was “directed to” ineligible subject matter, while the claim in *Diehr* was not. See Andres Sawicki, *The Central Claiming Renaissance*, 103 CORNELL L. REV. 645, 704-07 (2018).

### C. Applying the Modern Framework

The *Mayo/Alice* framework has had an enormous impact on contemporary patent practice. Its impacts have been particularly acute in the fields of software, biotechnology, and medical diagnostics. In each of those fields, § 101 has become the principal hurdle to obtaining a patent, and the primary mechanism for attacking an issued patent. For a comprehensive overview of the post-*Alice* landscape, see Jeffrey A. Lefstin, Peter S. Menell, & David O. Taylor, *Final Report of the Berkeley Center for Law & Technology Section 101 Workshop: Addressing Patent Eligibility Challenges*, 33 BERKELEY TECH. L.J. 551 (2018).

The Federal Circuit, the district courts, and the USPTO have all weighed in on the flurry of Section 101 issues being presented in the wake of the Court’s recent eligibility jurisprudence. As you read the following opinions, consider whether they help clarify (1) what it means for a claim to be “directed to” ineligible subject matter; (2) what kinds of things qualify as an “inventive concept” that would save an otherwise ineligible claim; and (3) how patentable subject matter relates to the “newness” and disclosure doctrines that are explored in more detail in other chapters. In addition, consider the procedural and institutional implications of the evolving eligibility doctrine.

*BASCOM Global Internet Services, Inc. v. AT&T Mobility LLC*  
827 F.3d 1341 (2016)

CHEN, Circuit Judge.

BASCOM Global Internet Services, Inc. appeals from the grant of a motion to dismiss under Rule 12(b)(6), in which the United States District Court for the Northern District of Texas held that . . . the claims of U.S. Patent No. 5,987,606 are invalid as a matter of law under 35 U.S.C. § 101. BASCOM has alleged that the claims of the '606 patent contain an “inventive concept” in their ordered combination of limitations sufficient to satisfy the second step of the Supreme Court’s *Alice* test. We find nothing in the intrinsic record to refute that allegation as a matter of law. We therefore vacate the district court’s order dismissing BASCOM’s complaint, and remand for further proceedings.

*Background*

The '606 patent was filed March 19, 1997. Back in 1997, the Internet was known to contain information that consumers, students, and businesses wanted to access. As the patent describes in the “Background of the Present Invention” section, web browsers “such as the Netscape Navigator™ or the Microsoft Explorer™” allowed users to access websites in the form of HTML files. Some websites, however, contained information deemed unsuitable for some users. . . .

The computer industry responded to this need by developing a software tool that allowed control over the type of information received over the Internet. The software tool inspected a user’s request to access a website and applied one or more filtering mechanisms: “exclusive filtering (‘black-listing’) which prevents access to all sites on a predetermined list of Internet sites; inclusive filtering (‘white-listing’) which allows access only to a predetermined list of Internet sites; and word-screening or phrase-screening which prevents access to web site ‘pages’ which contain any word or phrase on a predetermined list.”

According to the '606 patent, filtering software was first placed on local computers, such that each local computer had its own tool for filtering websites (or other Internet content) requested by the operator of the computer. . . .

To overcome some of the disadvantages of installing filtering software on each local computer, another prior art system relocated the filter to a local server. For example, a corporation with one connection to the Internet might have placed a server between the computers of its employees and the Internet connection. . . . “A computer literate end-user” therefore could no longer easily “modify or thwart” the filtering tool to gain access to blocked websites. However, the one-size-fits-all filter on the local server was not ideal

because “a single set of filtering criteria is often not appropriate for all of the end-users.”  
...

[The same tradeoffs existed when] some Internet Service Providers (ISPs), such as “America Online,” installed a filter on their remote servers . . . .

The '606 patent describes its invention as combining the advantages of the then-known filtering tools while avoiding their drawbacks. . . .

The claimed invention is able to provide individually customizable filtering at the remote ISP server by taking advantage of the technical capability of certain communication networks. In these networks, the ISP is able to associate an individual user with a specific request to access a website (or other Internet content), and can distinguish that user's requests from other users' requests. One way that the ISP is able to make this association, as described in the '606 patent, is by requiring each user to first complete a log-in process with the ISP server. After a user has logged in, the ISP server can associate the user with a request to access a specific website. Because the filtering tool on the ISP server contains each user's customized filtering mechanism, the filtering tool working in combination with the ISP server can apply a specific user's filtering mechanism to the websites requested by that user. . . . The '606 patent describes its filtering system as a novel advance over prior art computer filters, in that no one had previously provided customized filters at a remote server.

The claims of the '606 patent generally recite a system for filtering Internet content. The claimed filtering system is located on a remote ISP server that associates each network account with (1) one or more filtering schemes and (2) at least one set of filtering elements from a plurality of sets of filtering elements, thereby allowing individual network accounts to customize the filtering of Internet traffic associated with the account. . . . For the individually customizable filtering claims, BASCOM points to claim 1 as instructive.

1. A content filtering system for filtering content retrieved from an Internet computer network by individual controlled access network accounts, said filtering system comprising:

a local client computer generating network access requests for said individual controlled access network accounts;

at least one filtering scheme;

a plurality of sets of logical filtering elements; and

a remote ISP server coupled to said client computer and said Internet computer network, said ISP server associating each said network account to at least one filtering scheme and at least one set of filtering elements, said ISP server further receiving said network access requests from said client computer and executing

said associated filtering scheme utilizing said associated set of logical filtering elements.

For the hybrid filtering scheme claims, BASCOM points to claim 23, which depends on claim 22, as instructive.

22. An ISP server for filtering content forwarded to controlled access network account generating network access requests at a remote client computer, each network access request including a destination address field, said ISP server comprising:

a master inclusive-list of allowed sites;

a plurality of sets of exclusive-lists of excluded sites, each controlled access network account associated with at least one set of said plurality of exclusive-lists of excluded sites; and

a filtering scheme, said filtering scheme allowing said network access request if said destination address exists on said master inclusive-list but not on said at least one associated exclusive-list, whereby said controlled access accounts may be uniquely associated with one or more sets of excluded sites.

23. The ISP server of claim 22 further comprising:

a plurality of inclusive-lists of allowed sites, each controlled access user associated with at least one of said plurality of inclusive-lists of allowed sites, said filtering program further allowing said network access request if said requested destination address exists on said at least one associated inclusive-list.

bBASCOM sued [AT&T]. AT&T moved to dismiss BASCOM's complaint under FRCP 12(b)(6), on the basis that each claim of the '606 patent was invalid under 35 U.S.C. § 101. . . .

*Standard of Review*

. . . We review the district court's determination of patent-eligibility under § 101 de novo.

*Discussion*

A patent may be obtained for "any new and useful process, machine, manufacture, or composition of matter, or any new and useful improvement thereof." 35 U.S.C. § 101. The Supreme Court has "long held that this provision contains an important implicit exception: Laws of nature, natural phenomena, and abstract ideas are not patentable." The Supreme Court has also consistently held that § 101 provides a basis for a patentability/validity determination that is independent of—and on an equal footing



with—any other statutory patentability provision. Courts may therefore dispose of patent-infringement claims under § 101 whenever procedurally appropriate. . . .

We have found software-related patents eligible under both steps of the test *Alice* sets out. We found a patent to a particular improvement to a database system patent-eligible under step one in *Enfish LLC v. Microsoft Corp.*, 822 F.3d 1327, 1339–40 (Fed. Cir. 2016). There, we found claim language reciting the invention’s specific improvements to help our determination in step one of the *Alice* framework that the invention was directed to those specific improvements in computer technology. But we also recognized that, “in other cases involving computer-related claims, there may be close calls about how to characterize what the claims are directed to.” “In such cases . . . an analysis of whether there are arguably concrete improvements in the recited computer technology could take place under step two.” That is, some inventions’ basic thrust might more easily be understood as directed to an abstract idea, but under step two of the *Alice* analysis, it might become clear that the specific improvements in the recited computer technology go beyond “well-understood, routine, conventional activities” and render the invention patent-eligible. . . .

The claims of the ‘606 patent are directed to filtering content on the Internet. Specifically, claim 1 is directed to a “content filtering system for filtering content retrieved from an Internet computer network.” Claim 22 similarly is directed to an “ISP server for filtering content.” The specification reinforces this notion by describing the invention as relating “generally to a method and system for filtering Internet content.” We agree with the district court that filtering content is an abstract idea because it is a longstanding, well-known method of organizing human behavior, similar to concepts previously found to be abstract. See *Intellectual Ventures I LLC v. Capital One Bank (USA)*, 792 F.3d 1363, 1367 (Fed. Cir. 2015) (holding that “tracking financial transactions to determine whether they exceed a pre-set spending limit (i.e., budgeting)” is an abstract idea that “is not meaningfully different from the ideas found to be abstract in other cases . . . involving methods of organizing human activity”); see also *Content Extraction*, 776 F.3d at 1347 (finding that “1) collecting data, 2) recognizing certain data within the collected data set, and 3) storing that recognized data in a memory” was an abstract idea because “data collection, recognition, and storage is undisputedly well-known” and “humans have always performed these functions”); *Digitech Image Techs., LLC v. Elecs. for Imaging, Inc.*, 758 F.3d 1344, 1350 (Fed. Cir. 2014) (finding that “a process of organizing information through mathematical correlations” is an abstract idea). An abstract idea on “an Internet computer network” or on a generic computer is still an abstract idea.

BASCOM argues that the claims are directed to something narrower: the specific implementation of filtering content set forth in the claim limitations. Specifically, BASCOM asserts that claim 1 is “directed to the more specific problem of providing

Internet-content filtering in a manner that can be customized for the person attempting to access such content while avoiding the need for (potentially millions of) local servers or computers to perform such filtering and while being less susceptible to circumvention by the user,” and claim 23 is directed to “the even more particular problem of structuring a filtering scheme not just to be effective, but also to make user-level customization remain administrable as users are added instead of becoming intractably complex.” We recognize that this court sometimes incorporates claim limitations into its articulation of the idea to which a claim is directed. *See Enfish*, 822 F.3d at 1337 (relying on a step of an algorithm . . . in defining the idea of a claim for step-one purposes). . . . The *Enfish* claims, understood in light of their specific limitations, were unambiguously directed to an improvement in computer capabilities. Here, in contrast, the claims and their specific limitations do not readily lend themselves to a step-one finding that they are directed to a nonabstract idea. . . .

We now turn to step two, and the search for an “inventive concept.” The “inventive concept” may arise in one or more of the individual claim limitations or in the ordered combination of the limitations. An inventive concept that transforms the abstract idea into a patent-eligible invention must be significantly more than the abstract idea itself, and cannot simply be an instruction to implement or apply the abstract idea on a computer.

The district court looked at each limitation individually and noted that the limitations “local client computer,” “remote ISP server,” “Internet computer network,” and “controlled access network accounts” are described in the specification as well-known generic computer components. The district court also noted that a filtering system is described in the specification as “any type of code which may be executed” along with database entries. *See* ’606 patent, 4:28–30 (“It will be obvious to one of ordinary skill in the art that the filtering scheme can be any of a number of known-schemes, or hybrids thereof.”). The district court then looked at the limitations collectively, and held that “filtering software, apparently composed of filtering schemes and filtering elements, was well-known in the prior art,” and “using ISP servers to filter content was well-known to practitioners.” The district court thus concluded that BASCOM had not asserted adequately that the claims disclose an inventive concept because the limitations, “considered individually, or as an ordered combination, are no more than routine additional steps involving generic computer components and the Internet, which interact in well-known ways to accomplish the abstract idea of filtering Internet content.”

We agree with the district court that the limitations of the claims, taken individually, recite generic computer, network and Internet components, none of which is inventive by itself. BASCOM does not assert that it invented local computers, ISP servers, networks, network accounts, or filtering. Nor does the specification describe those elements as inventive.

## PATENTABLE SUBJECT MATTER

However, we disagree with the district court's analysis of the ordered combination of limitations. In light of *Mayo* and *Alice*, it is of course now standard for a § 101 inquiry to consider whether various claim elements simply recite "well-understood, routine, conventional activities." The district court's analysis in this case, however, looks similar to an obviousness analysis under 35 U.S.C. § 103, except lacking an explanation of a reason to combine the limitations as claimed. The inventive concept inquiry requires more than recognizing that each claim element, by itself, was known in the art. As is the case here, an inventive concept can be found in the non-conventional and non-generic arrangement of known, conventional pieces.

The inventive concept described and claimed in the '606 patent is the installation of a filtering tool at a specific location, remote from the end-users, with customizable filtering features specific to each end user. This design gives the filtering tool both the benefits of a filter on a local computer and the benefits of a filter on the ISP server. BASCOM explains that the inventive concept rests on taking advantage of the ability of at least some ISPs to identify individual accounts that communicate with the ISP server, and to associate a request for Internet content with a specific individual account. . . . [T]he inventive concept harnesses this technical feature of network technology in a filtering system by associating individual accounts with their own filtering scheme and elements while locating the filtering system on an ISP server. *See Research Corp. Techs. v. Microsoft Corp.*, 627 F.3d 859, 869 (Fed. Cir. 2010) ("Inventions with specific applications or improvements to technologies in the marketplace are not likely to be so abstract that they override the statutory language and framework of the Patent Act."). On this limited record, this specific method of filtering Internet content cannot be said, as a matter of law, to have been conventional or generic.

The claims do not merely recite the abstract idea of filtering content along with the requirement to perform it on the Internet, or to perform it on a set of generic computer components. Such claims would not contain an inventive concept. *See CyberSource Corp. v. Retail Decisions, Inc.*, 654 F.3d 1366, 1370 (Fed. Cir. 2011) (reasoning that the use of the Internet to verify a credit card transaction does not meaningfully add to the abstract idea of verifying the transaction). Nor do the claims preempt all ways of filtering content on the Internet; rather, they recite a specific, discrete implementation of the abstract idea of filtering content. Filtering content on the Internet was already a known concept, and the patent describes how its particular arrangement of elements is a technical improvement over prior art ways of filtering such content. . . . [P]rior art filters were either susceptible to hacking and dependent on local hardware and software, or confined to an inflexible one-size-fits-all scheme. BASCOM asserts that the inventors recognized there could be a filter implementation versatile enough that it could be adapted to many different users' preferences while also installed remotely in a single location. Thus, construed in favor of

the nonmovant—BASCOM—the claims are “more than a drafting effort designed to monopolize the [abstract idea].” Instead, the claims may be read to “improve an existing technological process.”

This court’s recent case law on step two of the *Alice* test further establishes the patent-eligibility of the claims before us. . . .

Turning first to *DDR*, we held that *DDR*’s patent claimed a technical solution to a problem unique to the Internet—websites instantly losing views upon the click of a link, which would send the viewer across cyberspace to another company’s website. The claimed invention solved that problem in a particular, technical way by sending the viewer to a hybrid webpage that combined visual elements of the first website with the desired content from the second website that the viewer wished to access. The creation of this hybrid webpage that co-displays the look and feel of the first website with the desired content from the second website required a specific technical solution that did more than claim all implementations for retaining web viewers.

Although the invention in *DDR*’s patent was engineered in the context of retaining potential customers, the invention was not claiming a business method *per se*, but was instead claiming a technical way to satisfy an existing problem for website hosts and viewers. Similarly, although the invention in the ’606 patent is engineered in the context of filtering content, the invention is not claiming the idea of filtering content simply applied to the Internet. The ’606 patent is instead claiming a technology-based solution (not an abstract-idea-based solution implemented with generic technical components in a conventional way) to filter content on the Internet that overcomes existing problems with other Internet filtering systems. By taking a prior art filter solution (one-size-fits-all filter at the ISP server) and making it more dynamic and efficient (providing individualized filtering at the ISP server), the claimed invention represents a “software-based invention that improves the performance of the computer system itself.”

. . .

As explained above, construed in favor of BASCOM as they must be in this procedural posture, the claims of the ’606 patent do not preempt the use of the abstract idea of filtering content on the Internet or on generic computer components performing conventional activities. The claims carve out a specific location for the filtering system (a remote ISP server) and require the filtering system to give users the ability to customize filtering for their individual network accounts.

#### *Conclusion*

While the claims of the ’606 patent are directed to the abstract idea of filtering content, BASCOM has adequately alleged that the claims pass step two of *Alice*’s two-part

PATENTABLE SUBJECT MATTER

framework. BASCOM has alleged that an inventive concept can be found in the ordered combination of claim limitations that transform the abstract idea of filtering content into a particular, practical application of that abstract idea. We find nothing on this record that refutes those allegations as a matter of law or justifies dismissal under Rule 12(b)(6). . . .

Vacated and remanded.

NEWMAN, Circuit Judge, concurring in the result.

I agree with the court that the claims of the Bascom patent are eligible for participation in the system of patents. . . . However, it has become increasingly apparent, as various factual situations have been brought into Section 101 challenges, that these new litigation opportunities have led to judicial protocols that are time-consuming and usually unnecessary. . . .

I write separately to urge a more flexible approach to the determination of patent eligibility, for the two-step protocol for ascertaining whether a patent is for an “abstract idea” is not always necessary to resolve patent disputes. There is no good reason why the district court should be constrained from determining patentability, instead of eligibility based on “abstract idea,” when the patentability/validity determination would be dispositive of the dispute.

*Patentability v. Eligibility*

A new and useful process or machine or manufacture or composition of matter is not an abstract idea, and if the claims are deemed to be so broad as to be abstract, application of the requirements of patentability is a direct path to resolution of validity disputes. Claims that are imprecise or that read on prior art or that are unsupported by description or that are not enabled raise questions of patentability, not eligibility.

35 U.S.C. § 112(a) requires a written description in “full, clear, concise, and exact terms,” and § 112(b) requires “claims particularly pointing out and distinctly claiming the subject matter” of the invention. The process, machine, manufacture, or composition of Section 101 must comply with Section 112. Subject matter that complies with Section 112 averts the generality or vagueness or imprecision or over-breadth that characterize abstract ideas. These are conditions of patentability, not of eligibility. The “conditions and requirements of this title” weed out the abstract idea.

The Court recognized that “all inventions at some level embody, use, reflect, rest upon, or apply . . . abstract ideas.” I have come upon no guide to when a claim crosses the boundary between unacceptable abstractness and acceptable specificity. Experience with this aspect demonstrates its imprecision. This conundrum is resolved on application of the criteria of patentability. Nor is this a new observation: “precedent illustrates that

pragmatic analysis of section 101 is facilitated by considerations analogous to those of section 102 and 103 as applied to the particular case.”

*AT&T's Motion to Dismiss*

In arguing “inventive concept,” both sides presented arguments that would also be relevant to patentability. . . . AT&T, supporting the “abstract idea” position on which it prevailed before the district court, argues that content filtration was a generally known concept, and thus was an “abstract idea” under *Alice* step one. AT&T argues that the Bascom filtration method is not an “inventive concept” under step two. AT&T also argues that the Bascom claims are invalid under Sections 103 and 112.

Bascom states that for issues under Sections 103 and 112, additional evidence would be provided, evidence not needed for response to a motion to dismiss for abstractness. We agree that Bascom must be accorded the opportunity to litigate these issues directly, rather than as overflow from the eligibility debate.

On appellate review, I agree with the majority that the Bascom claims contain an “inventive concept” in the claims’ “ordered combination of limitations,” and that this establishes eligibility. In the district court, the only issue that was finally decided is that of eligibility. Thus remand is the appropriate next step. However, I again point to the increased efficiency, and savings in cost and time, by direct resolution of patentability. The Court’s rulings in *Alice* and *Mayo* do not require that every broadly claimed patent must be treated in two separate litigation procedures, if charged with abstractness.

While the two-step protocol helps to decide whether a particular claim is “eligible” for patenting, we should clarify the district court’s authority to resolve the issues of patent validity directly. Direct application to the Bascom claims of the law of sections 102, 103, or 112, could have resolved this dispute in one litigation cycle of trial and appeal, instead of the repeated effort now required.

### Context and Application

1. What did *BASCOM* identify as the inventive concept in the claims? Was it the technological nature of what the patent purported to cover that saved it? Or was it the fact that others hadn’t done quite the same thing before the inventor’s work? If the latter, how does the eligibility analysis differ from an analysis that looks for whether the claim is novel and nonobvious?

2. Judge Newman’s concurrence emphasizes procedural considerations associated with the eligibility determination. Many of her concerns flow from the fact that eligibility decisions are frequently made on motions to dismiss, rather than at summary judgment or trial. As a result of trial courts’ tendency to resolve Section 101 challenges before

PATENTABLE SUBJECT MATTER

discovery, other potentially dispositive questions (including on issues like nonobviousness or enablement) are not resolved before appeal. The consequence is that alleged infringers prevail in the trial court on eligibility grounds, patentees then prevail on appeal, and the process must return to the trial court for resolution of all other issues, before ultimately (in many cases) returning to the appellate court. Judge Newman argues that trial courts should defer consideration of eligibility questions until after other matters are resolved. Are you persuaded that eligibility should be considered only after novelty and nonobviousness are resolved? *See* Paul R. Gugliuzza, *Quick Decisions in Patent Cases*, 106 GEO. L.J. 619, 649-63 (2018) (defending the reliance on patent eligibility as “a mechanism to dismiss low-merit suits before the parties incur significant litigation costs); Dennis Crouch & Robert P. Merges, *Operating Efficiently Post-Bilski by Ordering Patent Doctrine Decision-Making*, 25 BERKELEY TECH. L.J. 1673 (2010) (arguing that courts should, where possible, resolve straightforward novelty and nonobviousness challenges before evaluating difficult eligibility ones).

*McRO, Inc. v. AI Namco Games Am., Inc.*  
837 F.3d 1299 (Fed. Cir. 2016)

REYNA, Circuit Judge.

This appeal is from a grant of judgment on the pleadings . . . that the asserted claims of U.S. Patent Nos. 6,307,576 and 6,611,278 are invalid. The United States District Court for the Central District of California found that the asserted claims are . . . invalid under 35 U.S.C. § 101. We hold that the ordered combination of claimed steps, using unconventional rules that relate sub-sequences of phonemes, timings, and morph weight sets, is not directed to an abstract idea and is therefore patent-eligible subject matter under § 101. Accordingly, we reverse.

*Background*

A

The '576 patent and the '278 patent were both issued to Maury Rosenfeld and are both titled “Method for Automatically Animating Lip Synchronization and Facial Expression of Animated Characters.” The '278 patent is a continuation of the '576 patent and shares the same written description.

1

The patents relate to automating part of a preexisting 3-D animation method. As explained in the background of the patents, the admitted prior art method uses multiple 3-D models of a character’s face to depict various facial expressions made during speech.

To animate the character as it speaks, the method morphs the character's expression between the models. The "neutral model" is the 3-D representation of the resting, neutral facial expression of an animated character. The other models of the character's face are known as "morph targets," and each one represents that face as it pronounces a phoneme, i.e., makes a certain sound. This visual representation of the character's face making a sound is also called a "viseme." An example morph target for the "aah" phoneme is shown below. Each of these morph targets and the neutral model has identified points, called "vertices," in certain places on the face. The set of differences in the location of these vertices (and the corresponding point on the face) between the neutral model and the morph target form a "delta set" of vectors representing the change in location of the vertices between the two models. For each morph target, there is a corresponding delta set consisting of the vectors by which the vertices on that morph target differ from the neutral model.

Facial expressions are described as a function of the amount each morph target, and its corresponding delta set, is applied to modify the character model. "In producing animation products, a value usually from 0 to 1 is assigned to each delta set by the animator and the value is called the 'morph weight.'" The set of morph weights for all the delta sets is called a "morph weight set." The neutral model is represented by a morph weight set with all morph weights of 0. A desired morph target is represented by the morph weight of 1 for that morph target's delta set and a morph weight of 0 for all other delta sets.

The power of this prior art animation method is in generating intermediate faces by using morph weights between 0 and 1 to blend together multiple morph targets. For example, the face halfway between the neutral model and the "oh" face can be expressed simply by setting the "oh" morph weight to 0.5. . . . For each morph weight set, the resulting facial expression is calculated by determining the displacement of each vertex from the neutral model as the product of the morph weights in the morph weight set and the corresponding delta sets for the morph targets.

Animation of the character and lip synchronization preexisting the invention was generally accomplished by an animator with the assistance of a computer. Animators used "a 'keyframe' approach, where the artist set the appropriate morph weights at certain important times ('keyframes')" instead of at every frame. Animators knew what phoneme a character pronounced at a given time from a "time aligned phonetic transcription" ("timed transcript"). This listed the "occurrence in time" of each phoneme the character pronounced . . . .

Animators, using a computer, manually determined the appropriate morph weight sets for each keyframe based on the phoneme timings in the timed transcript. "For each keyframe, the artist would look at the screen and, relying on her judgment, manipulate



the character model until it looked right—a visual and subjective process.” . . . . A computer program would then interpolate between the keyframes set by the animator, creating the intermediate frames by determining the appropriate morph weight sets at intermediate points in time simply based on continuously transitioning between the keyframes.

## 2

The patents criticize the preexisting keyframe approach as “very tedious and time consuming, as well as inaccurate due to the large number of keyframes necessary to depict speech.” . . .

Essentially, the patents aim to automate a 3-D animator’s tasks, specifically, determining when to set keyframes and setting those keyframes. This automation is accomplished through rules that are applied to the timed transcript to determine the morph weight outputs. The patents describe many exemplary rule sets that go beyond simply matching single phonemes from the timed transcript with the appropriate morph target. Instead, these rule sets aim to produce more realistic speech by “taking into consideration the differences in mouth positions for similar phonemes based on context.”

One exemplary set of rules provided and applied in the specification of the ’576 patent is for a character transitioning from silence through saying “hello.” This exemplary set of rules provides for inserting a transition starting shortly before the first syllable after a silence. The transition marks when the character begins to transition from silence, shown by the closed-mouthed neutral model, to the morph target for the first syllable, with its open-mouthed shape. That is, the rule automates a character’s facial expressions so the character will wait until shortly before it starts speaking to begin opening its mouth. In terms of the prior art method, the effect of this rule is to automatically create a keyframe at a point that no phoneme is being pronounced. If instead no transition were placed at that position, the resulting animation would have an unrealistic quality. The character would open its mouth gradually from the beginning of the sequence through its first utterance as a result of the computer interpolating a continuous transition between those two points. In the prior art system, an animator would have to subjectively identify the problematic sequence and manually fix it by adding an appropriate keyframe. The invention, however, uses rules to automatically set a keyframe at the correct point to depict more realistic speech, achieving results similar to those previously achieved manually by animators.

Claim 1 of the ’576 patent is representative and dispositive of the asserted claims for the purposes of appeal:

A method for automatically animating lip synchronization and facial expression of three-dimensional characters comprising:

## CHAPTER 3

obtaining a first set of rules that define output morph weight set stream as a function of phoneme sequence and time of said phoneme sequence;

obtaining a timed data file of phonemes having a plurality of sub-sequences;

generating an intermediate stream of output morph weight sets and a plurality of transition parameters between two adjacent morph weight sets by evaluating said plurality of sub-sequences against said first set of rules;

generating a final stream of output morph weight sets at a desired frame rate from said intermediate stream of output morph weight sets and said plurality of transition parameters; and

applying said final stream of output morph weight sets to a sequence of animated characters to produce lip synchronization and facial expression control of said animated characters.

### *Standard of Review*

... We also review de novo whether a claim is invalid under the judicially created exceptions to § 101.

### *Discussion*

#### A

As an initial matter, we note that, in this case, claim construction is helpful to resolve the question of patentability under § 101. Specifically, the parties' dispute about whether the "first set of rules" must evaluate sequential phonemes or can evaluate individual phonemes is resolved by the claim language. We agree with McRO that the claims are limited to rules that evaluate sub-sequences consisting of multiple sequential phonemes. This limitation is apparent on the face of the claims. In particular, the intermediate morph weight sets and transition parameters are generated "by evaluating said plurality of sub-sequences against said first set of rules." This limitation could not be satisfied by rules that only evaluate individual phonemes. Instead, the claimed "first set of rules" must be formulated to evaluate sub-sequences of phonemes.

#### B

This appeal involves the abstract idea exception.

In *Alice*, the Court applied a two-step framework for analyzing whether claims are patent eligible. First, we determine whether the claim at issue is "directed to" a judicial exception, such as an abstract idea. Mathematical formulas are a type of abstract idea. The abstract idea exception prevents patenting a result where "it matters not by what process or machinery the result is accomplished." *O'Reilly v. Morse*, 56 U.S. (15 How.) 62, 113,

(1854). We do not assume that such claims are directed to patent ineligible subject matter because “all inventions at some level embody, use, reflect, rest upon, or apply laws of nature, natural phenomena, or abstract ideas.” Instead, “the claims are considered in their entirety to ascertain whether their character as a whole is directed to excluded subject matter.” . . .

In *Alice*, the Court applied some of its § 101 jurisprudence that preceded the two-step framework, including *Flook* and *Diehr*. In *Flook*, claims requiring the use of a specific equation were unpatentable because they “simply provided a new and presumably better method of calculating alarm limit values.” The mathematical “formula itself was an abstract idea” and “the computer implementation was purely conventional” because “the use of computers for automatic monitoring-alarming was well known.” “*Flook* stands for the proposition that the prohibition against patenting abstract ideas cannot be circumvented by attempting to limit the use of the idea to a particular technological environment.” *Alice*, 134 S. Ct. at 2358.

The claims in *Diehr*, in contrast, were patentable. The claims likewise “employed a well-known mathematical equation.” A computer performed the calculations as part of a broader process for curing rubber, but “the process as a whole did not thereby become unpatentable subject matter.” Instead, the Court looked to how the claims “used that equation in a process designed to solve a technological problem in conventional industry practice.” When looked at as a whole, “the claims in *Diehr* were patent eligible because they improved an existing technological process, not because they were implemented on a computer.” *Alice*, 134 S. Ct. at 2358.

1

The district court determined that claim 1 of the ‘567 patent is “drawn to the abstract idea of automated rules-based use of morph targets and delta sets for lip-synchronized three-dimensional animation.” We disagree. We have previously cautioned that courts “must be careful to avoid oversimplifying the claims” by looking at them generally and failing to account for the specific requirements of the claims. Here, the claims are limited to rules with specific characteristics. As the district court recognized during claim construction, “the claims themselves set out meaningful requirements for the first set of rules: they ‘define a morph weight set stream as a function of phoneme sequence and times associated with said phoneme sequence.’” They further require “applying said first set of rules to each sub-sequence . . . of timed phonemes.” Whether at step one or step two of the *Alice* test, in determining the patentability of a method, a court must look to the claims as an ordered combination, without ignoring the requirements of the individual steps. The specific, claimed features of these rules allow for the improvement realized by the invention.

As the specification confirms, the claimed improvement here is allowing computers to produce “accurate and realistic lip synchronization and facial expressions in animated characters” that previously could only be produced by human animators. As the district court correctly recognized, this computer automation is realized by improving the prior art through “the use of rules, rather than artists, to set the morph weights and transitions between phonemes.” The rules are limiting in that they define morph weight sets as a function of the timing of phoneme sub-sequences. Defendants do not dispute that processes that automate tasks that humans are capable of performing are patent eligible if properly claimed; instead, they argue that the claims here are abstract because they do not claim specific rules. This argument echoes the district court’s finding that the claims improperly purport to cover all rules. The claimed rules here, however, are limited to rules with certain common characteristics, i.e., a genus.

Claims to the genus of an invention, rather than a particular species, have long been acknowledged as patentable. *E.g.*, *Diamond v. Chakrabarty*, 447 U.S. 303, 305 (1980) (patentable claim to “a bacterium from the genus *Pseudomonas* containing therein at least two stable energy-generating plasmids, each of said plasmids providing a separate hydrocarbon degradative pathway.”). Patent law has evolved to place additional requirements on patentees seeking to claim a genus; however, these limits have not been in relation to the abstract idea exception to § 101. Rather they have principally been in terms of whether the patentee has satisfied the tradeoff of broad disclosure for broad claim scope implicit in 35 U.S.C. § 112. It is self-evident that genus claims create a greater risk of preemption, thus implicating the primary concern driving § 101 jurisprudence, but this does not mean they are unpatentable.

The preemption concern arises when the claims are not directed to a specific invention and instead improperly monopolize “the basic tools of scientific and technological work.” The abstract idea exception has been applied to prevent patenting of claims that abstractly cover results where “it matters not by what process or machinery the result is accomplished.” *Morse*, 56 U.S. at 113; *see also Mayo*, 132 S. Ct. at 1301. “A patent is not good for an effect, or the result of a certain process” because such patents “would prohibit all other persons from making the same thing by any means whatsoever.” *Le Roy v. Tatham*, 55 U.S. (14 How.) 156, 175 (1853). A patent may issue “for the means or method of producing a certain result, or effect, and not for the result or effect produced.” *Diehr*, 450 U.S. 175, 182 n.7. We therefore look to whether the claims in these patents focus on a specific means or method that improves the relevant technology or are instead directed to a result or effect that itself is the abstract idea and merely invoke generic processes and machinery.

Claim 1 of the '576 patent is focused on a specific asserted improvement in computer animation, i.e., the automatic use of rules of a particular type. We disagree with Defendants' arguments that the claims simply use a computer as a tool to automate conventional activity. While the rules are embodied in computer software that is processed by general-purpose computers, Defendants provided no evidence that the process previously used by animators is the same as the process required by the claims. In support, Defendants point to the background section of the patents, but that information makes no suggestion that animators were previously employing the type of rules required by claim 1. Defendants concede an animator's process was driven by subjective determinations rather than specific, limited mathematical rules. The prior art "animator would decide what the animated face should look like at key points in time between the start and end times, and then 'draw' the face at those times." The computer here is employed to perform a distinct process to automate a task previously performed by humans. McRO states that animators would initially set keyframes at the point a phoneme was pronounced to represent the corresponding morph target as a starting point for further fine tuning. This activity, even if automated by rules, would not be within the scope of the claims because it does not evaluate sub-sequences, generate transition parameters or apply transition parameters to create a final morph weight set. It is the incorporation of the claimed rules, not the use of the computer, that "improved the existing technological process" by allowing the automation of further tasks. This is unlike *Flook*, *Bilski*, and *Alice*, where the claimed computer-automated process and the prior method were carried out in the same way.

Further, the automation goes beyond merely "organizing existing information into a new form" or carrying out a fundamental economic practice. The claimed process uses a combined order of specific rules that renders information into a specific format that is then used and applied to create desired results: a sequence of synchronized, animated characters. While the result may not be tangible, there is nothing that requires a method "be tied to a machine or transform an article" to be patentable. The concern underlying the exceptions to § 101 is not tangibility, but preemption. *Mayo*, 132 S.Ct. at 1301.

The limitations in claim 1 prevent preemption of all processes for achieving automated lip-synchronization of 3-D characters. McRO has demonstrated that motion capture animation provides an alternative process for automatically animating lip synchronization and facial expressions. Even so, we have recognized that "the absence of complete preemption does not demonstrate patent eligibility." The narrower concern here is whether the claimed genus of rules preempts all techniques for automating 3-D animation that rely on rules. Claim 1 requires that the rules be rendered in a specific way: as a relationship between sub-sequences of phonemes, timing, and the weight to which

each phoneme is expressed visually at a particular timing (as represented by the morph weight set). The specific structure of the claimed rules would prevent broad preemption of all rules-based means of automating lip synchronization, unless the limits of the rules themselves are broad enough to cover all possible approaches.

...

Defendants' attorney's argument that any rules-based lip-synchronization process must use the claimed type of rules has appeal, but no record evidence supports this conclusion. Defendants again rely only on the patents' description of one type of rules, but the description of one set of rules does not mean that there exists only one set of rules, and does not support the view that other possible types of rules with different characteristics do not exist. The only information cited to this court about the relationship between speech and face shape points to the conclusion that there are many other possible approaches to automating lip synchronization using rules. For example, Amicus cites *Kiyoshi Honda, Physiological Processes of Speech Processing*, in *SPRINGER HANDBOOK OF SPEECH PRODUCTION* 7 (Jacob Benesty et al. eds., 2008), as support for the proposition that the claimed rules reflect natural laws. Honda shows, however, that the interaction between vocalization and facial expression is very complex, and there are relationships present other than those required by the claimed rules. This complex interaction permits development of alternative rules-based methods of animating lip synchronization and facial expressions of three-dimensional characters, such as simulating the muscle action underlying characters' facial expressions. Under these circumstances, therefore, we need not assume that future alternative discoveries are foreclosed.

Here, the structure of the limited rules reflects a specific implementation not demonstrated as that which "any animator engaged in the search for an automation process would likely have utilized." By incorporating the specific features of the rules as claim limitations, claim 1 is limited to a specific process for automatically animating characters using particular information and techniques and does not preempt approaches that use rules of a different structure or different techniques. *See Morse*, 56 U.S. at 113. When looked at as a whole, claim 1 is directed to a patentable, technological improvement over the existing, manual 3-D animation techniques. The claim uses the limited rules in a process specifically designed to achieve an improved technological result in conventional industry practice. . . .

Because we find that claim 1 is not directed to ineligible subject matter, we do not reach *Alice* step two. . . .

## Context and Application

1. The claims in *McRO* were deemed to be directed to patentable subject matter. In contrast, the claims in *BASCOM* were deemed to be directed to an ineligible abstract idea (although they were ultimately eligible because they contained an inventive concept). What differences in the claims account for this?

*Ariosa Diagnostics, Inc. v. Sequenom, Inc.*  
788 F.3d 1371 (Fed. Cir. 2015)

REYNA, Circuit Judge.

This appeal is from a grant of summary judgment of invalidity of the asserted claims of U.S. Patent No. 6,258,540. The United States District Court for the Northern District of California found that the asserted claims of the '540 patent are not directed to patent eligible subject matter and are therefore invalid under 35 U.S.C. § 101. For the reasons explained below, we affirm.

### I

In 1996, Drs. Dennis Lo and James Wainscoat discovered cell-free fetal DNA (“cffDNA”) in maternal plasma and serum, the portion of maternal blood samples that other researchers had previously discarded as medical waste. cffDNA is non-cellular fetal DNA that circulates freely in the blood stream of a pregnant woman. Applying a combination of known laboratory techniques to their discovery, Drs. Lo and Wainscoat implemented a method for detecting the small fraction of paternally inherited cffDNA in maternal plasma or serum to determine fetal characteristics, such as gender. The invention, commercialized by Sequenom as its MaterniT21 test, created an alternative for prenatal diagnosis of fetal DNA that avoids the risks of widely-used techniques that took samples from the fetus or placenta. In 2001, Drs. Lo and Wainscoat obtained the '540 patent . . . .

The parties agree that the patent does not claim cffDNA or paternally inherited cffDNA. Instead, the '540 patent claims certain methods of using cffDNA. The steps of the method of claim 1 . . . include amplifying the cffDNA contained in a sample of a plasma or serum from a pregnant female and detecting the paternally inherited cffDNA. . . . In the amplification step, DNA is extracted from the serum or plasma samples and amplified by polymerase chain reaction (“PCR”) or another method. PCR exponentially amplifies the cffDNA sample to detectable levels.

In the detecting step, the lab technician adds the amplified cffDNA to an agarose gel containing ethidium bromide to stain and visualize the paternally inherited cffDNA.

## CHAPTER 3

The '540 patent also provides for making a diagnosis of certain fetal characteristics based on the detection of paternally inherited cffDNA. The specification explains that analysis of cffDNA permits more efficient determination of genetic defects and that a pregnant woman carrying a fetus with certain genetic defects will have more cffDNA in her blood than will a woman with a normal fetus.

Claims 1, 2, 4, 5, 8, 19–22, 24, and 25 of the '540 patent are at issue in this appeal. Independent claim 1 [which the parties stipulated is representative] requires:

1. A method for detecting a paternally inherited nucleic acid of fetal origin performed on a maternal serum or plasma sample from a pregnant female, which method comprises

amplifying a paternally inherited nucleic acid from the serum or plasma sample and

detecting the presence of a paternally inherited nucleic acid of fetal origin in the sample.

### II

Appellee Ariosa Diagnostics, Inc. . . . makes and sells the Harmony Test, a non-invasive test used for prenatal diagnosis of certain fetal characteristics. . . .

. . . [T]he parties filed cross motions for summary judgment regarding invalidity under 35 U.S.C. § 101. The district court agreed with Ariosa's argument that the claims of the '540 patent were directed to the natural phenomenon of paternally inherited cffDNA and that the claims did not add enough to the natural phenomenon to make the claims patent eligible under § 101. . . .

### III

We review . . . de novo the question of whether a claim is invalid under section 101.

. . .

In *Mayo Collaborative Services v. Prometheus Laboratories, Inc.*, 566 U.S. 66 (2012), the Supreme Court set forth a framework for distinguishing patents that claim laws of nature, natural phenomena, and abstract ideas from those that claim patent-eligible applications of those concepts. First, we determine whether the claims at issue are directed to a patent-ineligible concept. If the answer is yes, then we next consider the elements of each claim both individually and "as an ordered combination" to determine whether additional elements "transform the nature of the claim" into a patent-eligible application. The Supreme Court has described the second step of this analysis as a search for an "inventive concept" — i.e., an element or combination of elements that is "sufficient to ensure that the



## PATENTABLE SUBJECT MATTER

patent in practice amounts to significantly more than a patent upon the ineligible concept itself.”

. . . [T]he asserted claims of the '540 patent are directed to a multistep method that starts with cffDNA taken from a sample of maternal plasma or serum—a naturally occurring non-cellular fetal DNA that circulates freely in the blood stream of a pregnant woman. It is undisputed that the existence of cffDNA in maternal blood is a natural phenomenon. Sequenom does not contend that Drs. Lo and Wainscoat created or altered any of the genetic information encoded in the cffDNA, and it is undisputed that the location of the nucleic acids existed in nature before Drs. Lo and Wainscoat found them. The method ends with paternally inherited cffDNA, which is also a natural phenomenon. The method therefore begins and ends with a natural phenomenon. Thus, the claims are directed to matter that is naturally occurring.

The written description supports the conclusion that the claims of the '540 patent are directed to a naturally occurring thing or natural phenomenon. In the Summary and Objects of the Invention section of the '540 patent, the patent states that “it has now been discovered that foetal DNA is detectable in maternal serum or plasma samples.” The patent goes on to state that “this is a surprising and unexpected finding; maternal plasma is the very material that is routinely discarded by investigators studying noninvasive prenatal diagnosis using foetal cells in maternal blood.” In the discussion, the patent notes: “In this study we have demonstrated the feasibility of performing non-invasive foetal RhD genotyping from maternal plasma. This represents the first description of single gene diagnosis from maternal plasma.”

Further, the description of the invention notes: “we have demonstrated that foetal DNA is present in maternal plasma and serum,” and “these observations indicate that maternal plasma/serum DNA may be a useful source of material for the non-invasive prenatal diagnosis of certain genetic disorders.” The patent also states: “the most important observation in this study is the very high concentration of foetal DNA in maternal plasma and serum.” Thus, the claims at issue, as informed by the specification, are generally directed to detecting the presence of a naturally occurring thing or a natural phenomenon, cffDNA in maternal plasma or serum. . . .

Because the claims at issue are directed to naturally occurring phenomena, we turn to the second step of *Mayo's* framework. In the second step, we examine the elements of the claim to determine whether the claim contains an inventive concept sufficient to “transform” the claimed naturally occurring phenomenon into a patent-eligible application. We conclude that the practice of the method claims does not result in an inventive concept that transforms the natural phenomenon of cffDNA into a patentable invention.

*Mayo* made clear that transformation into a patent-eligible application requires “more than simply stating the law of nature while adding the words ‘apply it.’” A claim that recites an abstract idea, law of nature, or natural phenomenon must include “additional features” to ensure “that the claim is more than a drafting effort designed to monopolize the abstract idea, law of nature, or natural phenomenon.” For process claims that encompass natural phenomenon, the process steps are the additional features that must be new and useful. *See Parker v. Flook*, 437 U.S. 584, 591 (1978).

...

Like the patentee in *Mayo*, Sequenom contends that the claimed methods are patent eligible applications of a natural phenomenon, specifically a method for detecting paternally inherited cffDNA. Using methods like PCR to amplify and detect cffDNA was well-understood, routine, and conventional activity in 1997. The method at issue here amounts to a general instruction to doctors to apply routine, conventional techniques when seeking to detect cffDNA. Because the method steps were well-understood, conventional and routine, the method of detecting paternally inherited cffDNA is not new and useful. The only subject matter new and useful as of the date of the application was the discovery of the presence of cffDNA in maternal plasma or serum.

The specification of the '540 patent confirms that the preparation and amplification of DNA sequences in plasma or serum were well-understood, routine, conventional activities performed by doctors in 1997. The '540 patent provides that “the preparation of serum or plasma from the maternal blood sample is carried out by standard techniques.” It also provides that “standard nucleic acid amplification systems can be used, including PCR, the ligase chain reaction, nucleic acid sequence based amplification (NASBA), branched DNA methods, and so on.”

Other evidence supports this conclusion. For example, Sequenom’s expert, Dr. Evans, testified at deposition that PCR and other methodologies for amplifying DNA were “already well known in science in 1997.” Similarly, in a declaration filed during prosecution of the '540 patent, Dr. Lo testified that “suitable amplification techniques can be ordinary PCR or more sophisticated developments thereof, but these techniques were all known in the literature before the date of my invention.”

The detecting step was similarly well-understood, routine, and conventional. During prosecution of the application that became the '540 patent, the applicant stated:

...

One skilled in the art is readily able to apply the teachings of the present application to any one of the well-known techniques for detection of DNA with a view to analysis of foetal DNA in paternal [sic] plasma or serum.

...

The dependent claims are broad examples of how to detect cffDNA in maternal plasma. The dependent claims are focused on the use of the natural phenomenon in combination with well-understood, routine, and conventional activity. For example, claim 2 identifies the polymerase chain reaction as the amplification technique to be used in the detection method of claim 1. As noted above, this technique was well-understood, routine, and conventional in 1997, as specified by the patent itself. Like claim 1, claims 5 and 8 focus on detecting a specific chromosome within the cffDNA—a natural phenomenon—again, adding no inventive concept to the limitations of claim 1. None of the remaining asserted dependent or independent claims differ substantially from these claims. Thus, in this case, appending routine, conventional steps to a natural phenomenon, specified at a high level of generality, is not enough to supply an inventive concept. Where claims of a method patent are directed to an application that starts and ends with a naturally occurring phenomenon, the patent fails to disclose patent eligible subject matter if the methods themselves are conventional, routine and well understood applications in the art. The claims of the '540 patent at issue in this appeal are not directed to patent eligible subject matter and are, therefore, invalid.

#### IV

In its opinion, the district court addressed the principle of preemption . . . :

The '540 patent does not merely claim uses or applications of cffDNA, it claims methods for detecting the natural phenomenon. Because generally one must be able to find a natural phenomenon to use it and apply it, claims covering the only commercially viable way of detecting that phenomenon do carry a substantial risk of preempting all practical uses of it.

Sequenom argues that there are numerous other uses of cffDNA aside from those claimed in the '540 patent, and thus, the '540 patent does not preempt all uses of cffDNA . . . . Sequenom also argues that “a method applying or using a natural phenomenon in a manner that does not preclude alternative methods in the same field is non-preemptive, and, by definition, patent-eligible under Section 101.” Similarly, Sequenom and amici argue that because the particular application of the natural phenomena that the '540 patent claims embody are narrow and specific, the claims should be upheld. . . .

The Supreme Court has made clear that the principle of preemption is the basis for the judicial exceptions to patentability. For this reason, questions on preemption are inherent in and resolved by the § 101 analysis. The concern is that “patent law not inhibit further discovery by improperly tying up the future use of these building blocks of human ingenuity.” In other words, patent claims should not prevent the use of the basic building blocks of technology—abstract ideas, naturally occurring phenomena, and natural laws.

While preemption may signal patent ineligible subject matter, the absence of complete preemption does not demonstrate patent eligibility. In this case, Sequenom's attempt to limit the breadth of the claims by showing alternative uses of cffDNA outside of the scope of the claims does not change the conclusion that the claims are directed to patent ineligible subject matter. Where a patent's claims are deemed only to disclose patent ineligible subject matter under the *Mayo* framework, as they are in this case, preemption concerns are fully addressed and made moot.

Sequenom and amici encourage us to draw distinctions among natural phenomena based on whether or not they will interfere significantly with innovation in other fields now or in the future. The Supreme Court cases, however, have not distinguished among different laws of nature or natural phenomenon according to whether or not the principles they embody are sufficiently narrow. In *Parker v. Flook*, the Supreme Court stated the issue in the case as follows: "The question in this case is whether the identification of a limited category of useful, though conventional, post-solution applications of such a formula makes respondent's method eligible for patent protection." The answer to that question was "no" because granting exclusive rights to the mathematical formula would be exempting it from any future use.

## V

For completeness, we address Sequenom's remaining arguments. Sequenom argues that "before the '540 patent, *no one* was using the plasma or serum of pregnant mothers to amplify and detect paternally-inherited cffDNA." This argument implies that the inventive concept lies in the discovery of cffDNA in plasma or serum. Even if so, this is not the invention claimed by the '540 patent.

Sequenom further argues that "one simple measure of Drs. Lo and Wainscoat's contribution is that their 1997 *Lancet* publication has been cited over a thousand times." Sequenom also notes that "the method reflects a significant human contribution in that Drs. Lo and Wainscoat combined and utilized man-made tools of biotechnology in a new way that revolutionized prenatal care." We agree but . . . the Supreme Court instructs that "groundbreaking, innovative, or even brilliant discovery does not by itself satisfy the § 101 inquiry." The discovery of the BRCA1 and BRCA2 genes was a significant contribution to the medical field, but it was not patentable. While Drs. Lo and Wainscoat's discovery regarding cffDNA may have been a significant contribution to the medical field, that alone does not make it patentable. We do not disagree that detecting cffDNA in maternal plasma or serum that before was discarded as waste material is a positive and valuable contribution to science. But even such valuable contributions can fall short of statutory patentable subject matter . . . .

LINN, Circuit Judge, concurring.

I join the court’s opinion invalidating the claims of the ‘540 patent only because I am bound by the sweeping language of the test set out in *Mayo Collaborative Services v. Prometheus Laboratories, Inc.*, 566 U.S. 66 (2012). In my view, the breadth of the second part of the test was unnecessary to the decision reached in *Mayo*. This case represents the consequence—perhaps unintended—of that broad language in excluding a meritorious invention from the patent protection it deserves and should have been entitled to retain.

...

In applying the second part of the test, the Supreme Court in *Mayo* discounted, seemingly without qualification, any “post-solution activity that is purely conventional or obvious.” This was unnecessary in *Mayo*, because doctors were already performing in combination all of the claimed steps of administering the drug at issue, measuring metabolite levels, and adjusting dosing based on the metabolite levels.

In *Diamond v. Diehr*, the Supreme Court held that “a new combination of steps in a process may be patentable even though all the constituents of the combination were well-known and in common use before the combination was made.” As *Mayo* explained: *Diehr* “pointed out that the basic mathematical equation, like a law of nature, was not patentable. But *Diehr* found the overall process patent eligible because of the way the additional steps of the process integrated the equation into the process as a whole.” Despite that recognition, *Mayo* discounted entirely the “conventional activity” recited in the claims in that case because the steps “add nothing specific to the laws of nature other than what is well-understood, routine, conventional activity, previously engaged in by those in the field.” While that conclusion might have been warranted in that case, given the fact that the “conventional activities” in *Mayo* were the very steps that doctors were already doing—administering the drug at issue, measuring metabolite levels, and adjusting dosing based on the metabolite levels—the Supreme Court did not limit its ruling to those particular facts and circumstances.

The Supreme Court’s blanket dismissal of conventional post-solution steps leaves no room to distinguish *Mayo* from this case, even though here *no one* was amplifying and detecting paternally-inherited cffDNA using the plasma or serum of pregnant mothers. Indeed, the maternal plasma used to be “routinely discarded,” ‘540 patent col. 1 ll.50–53, because, as Dr. Evans testified, “nobody thought that fetal cell-free DNA would be present.”

It is hard to deny that Sequenom’s invention is truly meritorious. Prior to the ‘540 patent, prenatal diagnoses required invasive methods, which “presented a degree of risk to the mother and to the pregnancy.” *Id.* at col. 1 ll.16–17. The available “techniques were time-consuming or required expensive equipment.” *Id.* at col. 1 ll.17–37. Dr. Mark Evans

testified that “despite years of trying by multiple methods, no one was ever able to achieve acceptable success and accuracy.” In a groundbreaking invention, Drs. Lo and Wainscoat discovered that there was cell-free fetal DNA in the maternal plasma. The Royal Society lauded this discovery as “a paradigm shift in non-invasive prenatal diagnosis,” and the inventors’ article describing this invention has been cited well over a thousand times. The commercial embodiment of the invention, the MaterniT21 test, was the first marketed non-invasive prenatal diagnostic test for fetal aneuploidies, such as Down’s syndrome, and presented fewer risks and a more dependable rate of abnormality detection than other tests. Unlike in *Mayo*, the ’540 patent claims a new method that should be patent eligible. While the instructions in the claims at issue in *Mayo* had been widely used by doctors—they had been measuring metabolites and recalculating dosages based on toxicity/inefficacy limits for years—here, the amplification and detection of cffDNA had never before been done. The new use of the previously discarded maternal plasma to achieve such an advantageous result is deserving of patent protection. Cf. Rebecca S. Eisenberg, *Prometheus Rebound: Diagnostics, Nature, and Mathematical Algorithms*, 122 YALE L.J. ONLINE 341, 343–44 (2013) (noting that despite *Mayo*’s declaration that a claim to “a new way of using an existing drug” is patentable, *Mayo*, it is unclear how a claim to new uses for existing drugs would survive *Mayo*’s sweeping test).

In short, Sequenom’s invention is nothing like the invention at issue in *Mayo*. Sequenom “effectuated a practical result and benefit not previously attained,” so its patent would traditionally have been valid. But for the sweeping language in the Supreme Court’s *Mayo* opinion, I see no reason, in policy or statute, why this breakthrough invention should be deemed patent ineligible.

### Context and Application

1. Of these three cases—*BASCOM*, *McRO*, and *Ariosa*—which contribution underlying the patent do you think contributed the most value to society (however you chose to understand “value to society”)? Which contribution most needed the incentives that patent law provides?

2. Do you agree with the court’s view that the claims here were indistinguishable from those in *Mayo*? What could the inventors in *Mayo* and those in *Ariosa* have done differently—either with respect to their inventive work or with respect specifically to their patent claims—to have obtained a valid patent?

## 4. UTILITY

Often, when people say “patents” they really mean “utility patents.” Utility patents, the only form of patent grant in the United States included in the Patent Act of 1790, are distinct from the later-added design and plant patents and will be the focus of this chapter.

Section 101 of the Patent Act provides:

Whoever invents or discovers any new and *useful* process, machine, manufacture, or composition of matter, or any new and *useful* improvement thereof, may obtain a patent therefor, subject to the conditions and requirements of this title.

35 U.S.C. § 101 (emphasis added). The concept of utility also appears in § 112 of the Patent Act, which provides:

The specification shall contain a written description of the invention, and of the manner and process of *making and using it*, in such full, clear, concise, and exact terms as to enable any person skilled in the art to which it pertains, or with which it is most nearly connected, to *make and use* the same, and shall set forth the best mode contemplated by the inventor or joint inventor of carrying out the invention.

35 U.S.C. § 112(a). These requirements—that a patentable invention be “useful” and that the patent document describe how to use it—form the basis for the utility doctrine.

But what does it mean for an invention to be useful? In patent law, “useful” does not mean the same thing as important. Inventions surrounding frivolous pursuits are patentable; they are useful in that they serve the purpose of bringing their users pleasure. As Sarah Rajec and Andrew Gilden explain in *Patenting Pleasure*:

The question of what is “useful” can be an incredibly complicated question about what pursuits are worthwhile and whether and how various inventions aid in those pursuits. Utility, it turns out, is inseparable from social norms about the worth of any given activity. . . A closer look shows that bringing pleasure has long been recognized as useful by the patent system. For example, the USPTO issued a patent to James L. Haven and Charles Hettrick in 1866 for a “new and useful bandelore,” now better known as a yo-yo. This was the same year Milton Bradley applied for a patent on a board game called “the checkered game of life,” which, although a game, is described as imparting on youthful minds “the great moral principles of virtue and vice.”

## CHAPTER 4

Andrew Gilden & Sarah R. Wasserman Rajec, *Patenting Pleasure* (draft at 12), available at [https://papers.ssrn.com/abstract\\_id=3792793](https://papers.ssrn.com/abstract_id=3792793).

A simple version of the utility doctrine is: A patented invention should have some purpose, and the specification should make that purpose clear. As you will see in *Lowell v. Lewis*, the courts have not always heavily enforced this patentability criteria, reasoning that there is little incentive to get or enforce patents on things that are useless and little cost to granting such patents. However, the utility requirement has served as a barrier in some circumstances.

Courts have developed three distinct strands of utility doctrine from the statutory language quoted above. The first is credible or operable utility: Is the invention capable of doing what it says it does? The second is beneficial or moral utility: Does the invention provide any social benefit—or, is it at least not socially harmful? The third is practical utility: Does the patent describe a specific and substantial utility? An invention must satisfy all three requirements to qualify for a utility patent, although generally only one sort of utility is relevant to any particular case.

### A. Credible Utility

Credible utility, also called operable utility, requires that a patent be able to do what it says it does. In simple terms, the doctrine bars patentability for impossible inventions, such as perpetual motion machines or time travel inventions. The Manual of Patent Examining Procedure instructs examiners not to impose a rejection based on lack of utility if the applicant has asserted a particular practical purpose and “the assertion would be considered credible by a person of ordinary skill in the art.” MPEP § 2107. Because the failure to assert that the invention credibly serves some purpose is also a failure to enable the invention, the MPEP pairs this rejection with an enablement rejection in an Examiner Note to the section.

However, the bar to credible utility is fairly low. The Federal Circuit has held that invalidity requires the claimed invention must be “totally incapable of achieving a useful result,” *Brooktree Corp. v. Advanced Micro Devices, Inc.*, 977 F.2d 1555, 1571 (Fed. Cir. 1992). Even if the invention performs a function “crudely,” that satisfies the requirement. And as we will see in *In re Brana*, partial success of an invention is enough to satisfy the requirement of credible utility.

### B. Beneficial Utility

Beneficial utility, also called moral utility, can be traced to a pair of cases from 1817 in which Justice Story sat by designation in Massachusetts district court. While *Lowell* has



been cited to reject patents for lack of morality, the invention at issue—an improvement to a pump—was not challenged as immoral. As you read the case, consider what sorts of value judgments are appropriate for different legal, political, and social institutions.

*Lowell v. Lewis*

15 F. Cas. 1018 (C.C.D. Mass. 1817)

STORY, Circuit Justice (charging jury).

The present action is brought by the plaintiff for a supposed infringement of a patent-right, granted, in 1813, to Mr. Jacob Perkins (from whom the plaintiff claims by assignment) for a new and useful improvement in the construction of pumps. The defendant asserts, in the first place, that the invention is neither new nor useful . . . .

To entitle the plaintiff to a verdict, he must establish, that his machine is a new and useful invention; and of these facts his patent is to be considered merely prima facie evidence of a very slight nature. He must, in the first place, establish it to be a useful invention; for the law will not allow the plaintiff to recover, if the invention be of a mischievous or injurious tendency. The defendant, however, has asserted a much more broad and sweeping doctrine; and one, which I feel myself called upon to negative in the most explicit manner. He contends, that it is necessary for the plaintiff to prove, that his invention is of general utility; so that in fact, for the ordinary purposes of life, it must supersede the pumps in common use. In short, that it must be, for the public, a better pump than the common pump; and that unless the plaintiff can establish this position, the law will not give him the benefit of a patent, even though in some peculiar cases his invention might be applied with advantage. I do not so understand the law. . . . All that the law requires is, that the invention should not be frivolous or injurious to the well-being, good policy, or sound morals of society. The word ‘useful,’ therefore, is incorporated into the act in contradistinction to mischievous or immoral. For instance, a new invention to poison people, or to promote debauchery, or to facilitate private assassination, is not a patentable invention. But if the invention steers wide of these objections, whether it be more or less useful is a circumstance very material to the interests of the patentee, but of no importance to the public. If it be not extensively useful, it will silently sink into contempt and disregard. There is no pretence, that Mr. Perkins’ pump is a mischievous invention; and if it has been used injuriously to the patentee by the defendant, it certainly does not lie in his mouth to contest its general utility. Indeed the defendant asserts, that Baker’s pump is useful in a very eminent degree, and, if it be substantially the same as Perkins’s, there is an end of the objection; if it be not substantially the same, then the plaintiff must fail in his action. So that, in either view, the abstract question seems hardly of any importance in this cause. . . .

## Context & Application

1. *Lowell* has come to stand for the proposition that the Patent Office and courts need not evaluate the relative merits of an invention in determining utility. Why does the court say that relative utility is “very material to the interests of the patentee, but of no importance to the public”? What happens to inventions that are useful, but not *as* useful as other inventions? And what do you make of the next sentence, where the court says that if the pumps are substantially the same, then there is an end of the objection (about utility)?

2. Why is this case cited for its holding about the morality of inventions? In another case decided the same year, Justice Story explained:

By useful invention, in the statute, is meant such a one as may be applied to some beneficial use in society, in contradistinction to an invention, which is injurious to the morals, the health, or the good order of society. It is not necessary to establish, that the invention is of such general utility, as to supersede all other inventions now in practice to accomplish the same purpose. It is sufficient, that it has no obnoxious or mischievous tendency, that it may be applied to practical uses, and that so far as it is applied, it is salutary. If its practical utility be very limited, it will follow, that it will be of little or no profit to the inventor; and if it be trifling, it will sink into utter neglect. The law, however, does not look to the degree of utility; it simply requires, that it shall be capable of use, and that the use is such as sound morals and policy do not discountenance or prohibit.

*Bedford v. Hunt*, 3 F. Cas. 37, 37 (C.C.D. Mass. 1817).

### *Juicy Whip, Inc. v. Orange Bang, Inc.* 185 F.3d 1364 (1999)

BRYSON, Circuit Judge.

The district court in this case held a patent invalid for lack of utility on the ground that the patented invention was designed to deceive customers by imitating another product and thereby increasing sales of a particular good. We reverse and remand.

Juicy Whip, Inc., is the assignee of US Pat. No. 5,575,405, which is entitled “Post-Mix Beverage Dispenser With an Associated Simulated Display of Beverage.” A “post-mix” beverage dispenser stores beverage syrup concentrate and water in separate locations until the beverage is ready to be dispensed. The syrup and water are mixed together immediately before the beverage is dispensed, which is usually after the consumer requests the beverage. In contrast, in a “pre-mix” beverage dispenser, the syrup

## UTILITY

concentrate and water are pre-mixed and the beverage is stored in a display reservoir bowl until it is ready to be dispensed. The display bowl is said to stimulate impulse buying by providing the consumer with a visual beverage display. A pre-mix display bowl, however, has a limited capacity and is subject to contamination by bacteria. It therefore must be refilled and cleaned frequently.

...

Section 101 of the Patent Act of 1952, 35 U.S.C. § 101, provides that “whoever invents or discovers any new and useful process, machine, manufacture, or composition of matter, or any new and useful improvement thereof,” may obtain a patent on the invention or discovery. The threshold of utility is not high: An invention is “useful” under section 101 if it is capable of providing some identifiable benefit. See *Brenner v. Manson*, 383 U.S. 519, 534, (1966); *Brooktree Corp. v. Advanced Micro Devices, Inc.*, 977 F.2d 1555, 1571 (Fed. Cir. 1992) (“To violate § 101 the claimed device must be totally incapable of achieving a useful result”); *Fuller v. Berger*, 120 F. 274, 275 (7th Cir. 1903) (test for utility is whether invention “is incapable of serving any beneficial end”).

To be sure, since Justice Story’s opinion in *Lowell v. Lewis*, it has been stated that inventions that are “injurious to the well-being, good policy, or sound morals of society” are unpatentable. As examples of such inventions, Justice Story listed “a new invention to poison people, or to promote debauchery, or to facilitate private assassination.” Courts have continued to recite Justice Story’s formulation, but the principle that inventions are invalid if they are principally designed to serve immoral or illegal purposes has not been applied broadly in recent years. For example, years ago courts invalidated patents on gambling devices on the ground that they were immoral, but that is no longer the law.

In holding the patent in this case invalid for lack of utility, the district court relied on two Second Circuit cases dating from the early years of this century, *Rickard v. Du Bon*, 103 F. 868 (2d Cir. 1900), and *Scott & Williams v. Aristo Hosiery Co.*, 7 F.2d 1003 (2d Cir. 1925). In the *Rickard* case, the court held invalid a patent on a process for treating tobacco plants to make their leaves appear spotted. At the time of the invention, according to the court, cigar smokers considered cigars with spotted wrappers to be of superior quality, and the invention was designed to make unspotted tobacco leaves appear to be of the spotted—and thus more desirable—type. The court noted that the invention did not promote the burning quality of the leaf or improve its quality in any way; “the only effect, if not the only object, of such treatment, is to spot the tobacco, and counterfeit the leaf spotted by natural causes.”

The *Aristo Hosiery* case concerned a patent claiming a seamless stocking with a structure on the back of the stocking that imitated a seamed stocking. The imitation was commercially useful because at the time of the invention many consumers regarded seams

in stockings as an indication of higher quality. The court noted that the imitation seam did not “change or improve the structure or the utility of the article,” and that the record in the case justified the conclusion that true seamed stockings were superior to the seamless stockings that were the subject of the patent. “At best,” the court stated, “the seamless stocking has imitation marks for the purposes of deception, and the idea prevails that with such imitation the article is more salable.” That was not enough, the court concluded, to render the invention patentable.

We decline to follow *Rickard* and *Aristo Hosiery*, as we do not regard them as representing the correct view of the doctrine of utility under the Patent Act of 1952. The fact that one product can be altered to make it look like another is in itself a specific benefit sufficient to satisfy the statutory requirement of utility.

It is not at all unusual for a product to be designed to appear to viewers to be something it is not. For example, cubic zirconium is designed to simulate a diamond, imitation gold leaf is designed to imitate real gold leaf, synthetic fabrics are designed to simulate expensive natural fabrics, and imitation leather is designed to look like real leather. In each case, the invention of the product or process that makes such imitation possible has “utility” within the meaning of the patent statute, and indeed there are numerous patents directed toward making one product imitate another. *See, e.g.*, U.S. Pat. No. 5,762,968 (method for producing imitation grill marks on food without using heat); U.S. Pat. No. 5,899,038 (laminated flooring imitating wood); U.S. Pat. No. 5,571,545 (imitation hamburger). Much of the value of such products resides in the fact that they appear to be something they are not. Thus, in this case the claimed post-mix dispenser meets the statutory requirement of utility by embodying the features of a post-mix dispenser while imitating the visual appearance of a pre-mix dispenser.

The fact that customers may believe they are receiving fluid directly from the display tank does not deprive the invention of utility. Orange Bang has not argued that it is unlawful to display a representation of the beverage in the manner that fluid is displayed in the reservoir of the invention, even though the fluid is not what the customer will actually receive. Moreover, even if the use of a reservoir containing fluid that is not dispensed is considered deceptive, that is not by itself sufficient to render the invention unpatentable. The requirement of “utility” in patent law is not a directive to the Patent and Trademark Office or the courts to serve as arbiters of deceptive trade practices. Other agencies, such as the Federal Trade Commission and the Food and Drug Administration, are assigned the task of protecting consumers from fraud and deception in the sale of food products. As the Supreme Court put the point more generally, “Congress never intended that the patent laws should displace the police powers of the States, meaning by that term those powers by which the health, good order, peace and general welfare of the community are promoted.” *Webber v. Virginia*, 103 U.S. 344, 347–48 (1880).

## UTILITY

Of course, Congress is free to declare particular types of inventions unpatentable for a variety of reasons, including deceptiveness. *Cf.* 42 U.S.C. § 2181(a) (exempting from patent protection inventions useful solely in connection with special nuclear material or atomic weapons). Until such time as Congress does so, however, we find no basis in section 101 to hold that inventions can be ruled unpatentable for lack of utility simply because they have the capacity to fool some members of the public. The district court therefore erred in holding that the invention of the '405 patent lacks utility because it deceives the public through imitation in a manner that is designed to increase product sales. Reversed and remanded.

### Context & Application

1. Is deception “injurious to the well-being, good policy, or sound morals of society?” Does it matter who is being deceived—or, to put it another way, does it matter who the audience for the deception is? Is the juice dispenser at issue in *Juicy Whip* more comparable to the gambling machines or the hosiery and tobacco leaves that were found unpatentable in the past?

2. Lowell and *Juicy Whip* are separated by 182 years, which included massive changes in social values and in patent doctrine. Perhaps the more important legal change was the rise of the administrative state. Is there reason to think that the existence of the FDA and the FTC make it less necessary to have the PTO determine what inventions are “injurious” to morals? Which direction does it cut that some agencies make ex ante decisions on protection (PTO) and market access (FDA) while others govern behavior ex post (FTC)? Does a robust moral utility requirement make it more or less likely that immoral goods will make it to market?

### C. Practical Utility

Practical utility is the area of utility doctrine with the most bite, particularly in modern times. It has developed primarily in fields surrounding chemistry and biochemistry. In mechanical fields, it is generally a simple enough matter to describe the utility of a machine—it moves itself or things from one place or state of matter to another place or state of matter. But it can be more difficult to discern or describe the utility of a new chemical composition. Sean Seymore has pointed out that judicial application of the doctrine results in technology-specific patentability requirements, allowing patents on inventions in most fields but providing a more serious bar to patentability in chemical fields as well as other unpredictable fields or new technologies that aren't yet well understood. *Making Patents Useful*, 98 MINN. L. REV. 1046 (2014). This is because of the

requirement that an inventor state the purpose of her invention. In unpredictable fields, inventors may discover a new molecule or develop a new organism that has promising qualities, but the specific use of which is not yet known. In a sense, the utility requirement, as applied in these novel and unpredictable technologies, is a timing requirement: an inventor must have done enough research to state a use for her invention before applying for a patent.

The Supreme Court set forth the current law of practical utility in *Brenner v. Manson* (1960). Two Federal Circuit cases, *In re Brana* (1995) and *In re Fisher* (2005) interpret and apply *Brenner* in different ways. As you read the cases, think about whether both Federal Circuit interpretations are consistent with *Brenner*, and with each other. What distinguishes them from each other, besides time? And, to the extent that practical utility is often a timing question of how far along researchers are in their discoveries, are differences in the state of the art sufficient to explain the different case outcomes?

*Brenner v. Manson*  
383 U.S. 519 (1966)

[In December 1957, Howard Ringold and George Rosenkranz applied for a patent on a novel process for making a known steroid, claiming priority to a Mexican filing on December 17, 1956. Manson filed an application for the same method three years later, but claimed an earlier priority date and requested an interference to determine who was entitled to the patent, under the first to invent system of priority. The Patent Office denied Manson's application on the ground that he had not disclosed utility for the chemical compound that was produced by the claimed process, unpersuaded by his argument that the steroids produced were of a class that was being screened for tumor-inhibiting properties in mice and that an adjacent homologue had proven effective in that role. The Court of Customs and Patent Appeals reversed, holding that "where a claimed process produces a known product it is not necessary to show utility for the product" so long as the product "is not alleged to be detrimental to the public interest." The Court granted certiorari.]

Mr. Justice FORTAS delivered the opinion of the Court.

Our starting point is the proposition, neither disputed nor disputable, that one may patent only that which is "useful." . . . [T]he concept of utility has maintained a central place in all of our patent legislation, beginning with the first patent law in 1790 and culminating in the present law's provision that

## UTILITY

Whoever invents or discovers any new and useful process, machine, manufacture, or composition of matter, or any new and useful improvement thereof, may obtain a patent therefor, subject to the conditions and requirements of this title.

As is so often the case, however, a simple, everyday word can be pregnant with ambiguity when applied to the facts of life. That this is so is demonstrated by the present conflict between the Patent Office and the CCPA over how the test is to be applied to a chemical process which yields an already known product whose utility—other than as a possible object of scientific inquiry—has not yet been evidenced. It was not long ago that agency and court seemed of one mind on the question. In *Application of Bremner*, 182 F.2d 216, 217 (C.C.P.A.) the court affirmed rejection by the Patent Office of both process and product claims. It noted that “no use for the products claimed to be developed by the processes had been shown in the specification.” It held that “It was never intended that a patent be granted upon a product, or a process producing a product, unless such product be useful.” Nor was this new doctrine in the court.

The Patent Office has remained steadfast in this view. The CCPA, however, has moved sharply away from *Bremner*. The trend began in *Application of Nelson*, 280 F.2d 172. There, the court reversed the Patent Office’s rejection of a claim on a process yielding chemical intermediates “useful to chemists doing research on steroids,” despite the absence of evidence that any of the steroids thus ultimately produced were themselves “useful.” The trend has accelerated, culminating in the present case where the court held it sufficient that a process produces the result intended and is not “detrimental to the public interest.”

It is not remarkable that differences arise as to how the test of usefulness is to be applied to chemical processes. Even if we knew precisely what Congress meant in 1790 when it devised the “new and useful” phraseology and in subsequent re-enactments of the test, we should have difficulty in applying it in the context of contemporary chemistry where research is as comprehensive as man’s grasp and where little or nothing is wholly beyond the pale of “utility” —if that word is given its broadest reach.

Respondent does not—at least in the first instance—rest upon the extreme proposition, advanced by the court below, that a novel chemical process is patentable so long as it yields the intended product and so long as the product is not itself “detrimental.” Nor does he commit the outcome of his claim to the slightly more conventional proposition that any process is “useful” within the meaning of § 101 if it produces a compound whose potential usefulness is under investigation by serious scientific researchers, although he urges this position, too, as an alternative basis for affirming the decision of the CCPA. Rather, he begins with the much more orthodox argument that his process has a specific utility which would entitle him to a declaration of interference even under the Patent Office’s reading of §101. The claim is that the supporting affidavits filed pursuant to Rule 204(b), by reference to Ringold’s 1956 article, reveal that an adjacent

homologue of the steroid yielded by his process has been demonstrated to have tumor-inhibiting effects in mice, and that this discloses the requisite utility. We do not accept any of these theories as an adequate basis for overriding the determination of the Patent Office that the “utility” requirement has not been met.

Even on the assumption that the process would be patentable were respondent to show that the steroid produced had a tumor-inhibiting effect in mice, we would not overrule the Patent Office finding that respondent has not made such a showing. The Patent Office held that, despite the reference to the adjacent homologue, respondent’s papers did not disclose a sufficient likelihood that the steroid yielded by his process would have similar tumor-inhibiting characteristics. Indeed, respondent himself recognized that the presumption that adjacent homologues have the same utility has been challenged in the steroid field because of “a greater known unpredictability of compounds in that field.” In these circumstances and in this technical area, we would not overturn the finding of the Primary Examiner, affirmed by the Board of Appeals and not challenged by the CCPA.

The second and third points of respondent’s argument present issues of much importance. Is a chemical process “useful” within the meaning of § 101 either (1) because it works—i.e., produces the intended product? or (2) because the compound yielded belongs to a class of compounds now the subject of serious scientific investigation? These contentions present the basic problem for our adjudication. Since we find no specific assistance in the legislative materials underlying § 101, we are remitted to an analysis of the problem in light of the general intent of Congress, the purposes of the patent system, and the implications of a decision one way or the other.

In support of his plea that we attenuate the requirement of “utility,” respondent relies upon Justice Story’s well-known statement that a “useful” invention is one “which may be applied to a beneficial use in society, in contradistinction to an invention injurious to the morals, health, or good order of society, or frivolous and insignificant” —and upon the assertion that to do so would encourage inventors of new processes to publicize the event for the benefit of the entire scientific community, thus widening the search for uses and increasing the fund of scientific knowledge. Justice Story’s language sheds little light on our subject. Narrowly read, it does no more than compel us to decide whether the invention in question is “frivolous and insignificant” —a query no easier of application than the one built into the statute. Read more broadly, so as to allow the patenting of any invention not positively harmful to society, it places such a special meaning on the word “useful” that we cannot accept it in the absence of evidence that Congress so intended. There are, after all, many things in this world which may not be considered “useful” but which, nevertheless are totally without a capacity for harm.



## UTILITY

It is true, of course, that one of the purposes of the patent system is to encourage dissemination of information concerning discoveries and inventions. And it may be that inability to patent a process to some extent discourages disclosure and leads to greater secrecy than would otherwise be the case. The inventor of the process, or the corporate organization by which he is employed, has some incentive to keep the invention secret while uses for the product are searched out. However, in light of the highly developed art of drafting patent claims so that they disclose as little useful information as possible—while broadening the scope of the claim as widely as possible—the argument based upon the virtue of disclosure must be warily evaluated. Moreover, the pressure for secrecy is easily exaggerated, for if the inventor of a process cannot himself ascertain a “use” for that which his process yields, he has every incentive to make his invention known to those able to do so. Finally, how likely is disclosure of a patented process to spur research by others into the uses to which the product may be put? To the extent that the patentee has power to enforce his patent, there is little incentive for others to undertake a search for uses.

Whatever weight is attached to the value of encouraging disclosure and of inhibiting secrecy, we believe a more compelling consideration is that a process patent in the chemical field, which has not been developed and pointed to the degree of specific utility, creates a monopoly of knowledge which should be granted only if clearly commanded by the statute. Until the process claim has been reduced to production of a product shown to be useful, the metes and bounds of that monopoly are not capable of precise delineation. It may engross a vast, unknown, and perhaps unknowable area. Such a patent may confer power to block off whole areas of scientific development, without compensating benefit to the public. The basic quid pro quo contemplated by the Constitution and the Congress for granting a patent monopoly is the benefit derived by the public from an invention with substantial utility. Unless and until a process is refined and developed to this point—where specific benefit exists in currently available form—there is insufficient justification for permitting an applicant to engross what may prove to be a broad field.

These arguments for and against the patentability of a process which either has no known use or is useful only in the sense that it may be an object of scientific research would apply equally to the patenting of the product produced by the process. Respondent appears to concede that with respect to a product, as opposed to a process, Congress has struck the balance on the side of nonpatentability unless “utility” is shown. Indeed, the decisions of the CCPA are in accord with the view that a product may not be patented absent a showing of utility greater than any adduced in the present case. We find absolutely no warrant for the proposition that although Congress intended that no patent be granted on a chemical compound whose sole “utility” consists of its potential role as an object of use-testing, a different set of rules was meant to apply to the process which yielded the

unpatentable product. That proposition seems to us little more than an attempt to evade the impact of the rules which concededly govern patentability of the product itself.

This is not to say that we mean to disparage the importance of contributions to the fund of scientific information short of the invention of something “useful,” or that we are blind to the prospect that what now seems without “use” may tomorrow command the grateful attention of the public. But a patent is not a hunting license. It is not a reward for the search, but compensation for its successful conclusion. “[A] patent system must be related to the world of commerce rather than to the realm of philosophy. . . .”

The judgment of the CCPA is reversed.

Mr. Justice HARLAN, concurring in part and dissenting in part.

What I find most troubling about the result reached by the Court is the impact it may have on chemical research. Chemistry is a highly interrelated field and a tangible benefit for society may be the outcome of a number of different discoveries, one discovery building upon the next. To encourage one chemist or research facility to invent and disseminate new processes and products may be vital to progress, although the product or process be without ‘utility’ as the Court defines the term, because that discovery permits someone else to take a further but perhaps less difficult step leading to a commercially useful item. In my view, our awareness in this age of the importance of achieving and publicizing basic research should lead this Court to resolve uncertainties in its favor and uphold the respondent’s position in this case.

...

Fully recognizing that there is ample room for disagreement on this problem when, as here, it is reviewed in the abstract, I believe the decision below should be affirmed.

### Context & Application

1. What does the Court mean when it invokes “the world of commerce” in opposition to “the realm of philosophy?”

2. Michael Risch has suggested reinvigorating the utility requirement through a doctrine of “commercial utility.” Risch explains that practical utility is already targeted towards commercial goals, but suggests that “granting patents only when a purpose is discovered might shift limited resources toward discovering how new chemicals might benefit society.” Michael Risch, *Reinventing Usefulness*, 2010 BYU L. REV. 1195 (2010). What are the benefits of allowing patents only for inventions that are ready for commercial distribution? What are the costs?

UTILITY

*In Re Brana*

51 F.3d 1560 (Fed. Cir. 1995)

PLAGER, Circuit Judge.

Miguel F. Brana, *et al.* (applicants), appeal the . . . decision of the United States Patent and Trademark Office (PTO) Board of Patent Appeals and Interferences (Board). The Board affirmed the examiner's rejection of claims 10–13 of patent application Serial No. 533,944 under 35 U.S.C. § 112 ¶ 1 [for lack of utility].

I

On June 30, 1988, applicants filed patent application Serial No. 213,690 (the '690 application) directed to 5-nitrobenzo[de]isoquinoline-1,3-dione compounds, for use as antitumor substances, having the following formula:

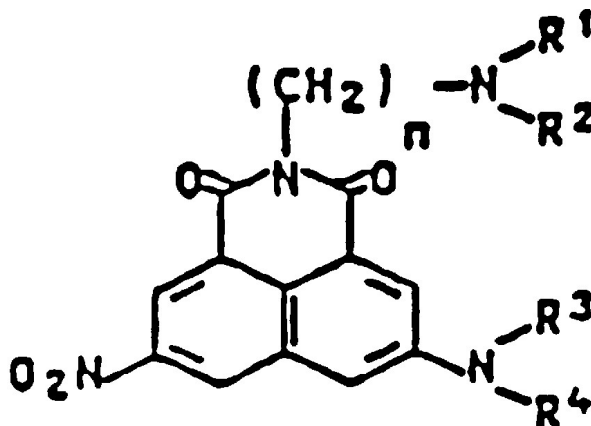

where n is 1 or 2, R<sub>1</sub> and R<sub>2</sub> are identical or different and are each hydrogen, C<sub>1</sub>–C<sub>6</sub>–alkyl, C<sub>1</sub>–C<sub>6</sub>–hydroxyalkyl, pyrrolidinyl, morpholino, piperidinyl or piperacetyl, and R<sub>3</sub> and R<sub>4</sub> are identical or different and are each hydrogen, C<sub>1</sub>–C<sub>6</sub>–alkyl, C<sub>1</sub>–C<sub>6</sub>–acyl, C<sub>2</sub>–C<sub>7</sub>–alkoxycarbonyl, ureyl, aminocarbonyl or C<sub>2</sub>–C<sub>7</sub>–alkylaminocarbonyl. These claimed compounds differ from several prior art benzo[de]isoquinoline-1,3-dione compounds due to the presence of a nitro group (O<sub>2</sub>N) at the 5-position and an amino or other amino group (NR<sub>3</sub>R<sub>4</sub>) at the 8-position of the isoquinoline ring.

The specification states that these non-symmetrical substitutions at the 5- and 8-positions produce compounds with “a better action and a better action spectrum as antitumor substances” than known benzo[de]isoquinolines, namely those in K.D. Paull *et al.*, Computer Assisted Structure–Activity Correlations, *Drug Research*, 34(II), 1243–46 (1984) (Paull). Paull describes a computer-assisted evaluation of benzo[de]isoquinoline-1,3-diones and related compounds which have been screened for antitumor activity by

testing their efficacy *in vivo* against two specific implanted murine (i.e., utilizing mice as test subjects) lymphocytic leukemias, P388 and L1210. These two *in vivo* tests are widely used by the National Cancer Institute (NCI) to measure the antitumor properties of a compound. Paull noted that one compound in particular, ["NSC 308847"], was found to show excellent activity against these two specific tumor models. Based on their analysis, compound NSC 308847 was selected for further studies by NCI. In addition to comparing the effectiveness of the claimed compounds with structurally similar compounds in Paull, applicants' patent specification illustrates the cytotoxicity of the claimed compounds against human tumor cells, *in vitro*, and concludes that these tests "had a good action."

The examiner initially rejected applicants' claims in the '690 application as obvious under 35 U.S.C. § 103 in light of U.S. Patent No. 4,614,820, issued to and referred to hereafter as Zee-Cheng et al. Zee-Cheng et al. discloses a benzo[de]isoquinoline compound for use as an antitumor agent with symmetrical substitutions on the 5-position and 8-position of the quinoline ring; in both positions the substitution was either an amino or nitro group.

In a response . . . , the applicants rebutted the § 103 rejection. Applicants asserted that their mixed disubstituted compounds had unexpectedly better antitumor properties than the symmetrically substituted compounds in Zee-Cheng et al. In support of this assertion applicants attached the declaration of Dr. Gerhard Keilhauer. In his declaration Dr. Keilhauer reported that his tests indicated that applicants' claimed compounds were far more effective as antitumor agents than the compounds disclosed in Zee-Cheng et al. when tested, *in vitro*, against two specific types of human tumor cells, HEp and HCT-29. . . . Although the applicants overcame the § 103 rejection, the examiner nevertheless issued a final rejection . . . based on 35 U.S.C. § 112 ¶ 1. The examiner first noted that the specification failed to describe any specific disease against which the claimed compounds were active. Furthermore, the examiner concluded that the prior art tests performed in Paull and the tests disclosed in the specification were not sufficient to establish a reasonable expectation that the claimed compounds had a practical utility (i.e. antitumor activity in humans).

[The Board affirmed the examiner's final rejection, relying entirely on the examiner's reasoning. the Board affirmed solely on the basis of the Examiner's § 112 ¶ 1 rejection. Applicants appealed.]

## II

At issue in this case is an important question of the legal constraints on patent office examination practice and policy. The question is, with regard to pharmaceutical inventions, what must the applicant prove regarding the practical utility or usefulness of the invention for which patent protection is sought.

## UTILITY

The requirement that an invention have utility is found in 35 U.S.C. § 101: “Whoever invents . . . any new and useful . . . composition of matter . . . may obtain a patent therefor . . . .” It is also implicit in § 112 ¶ 1, which reads:

The specification shall contain a written description of the invention, and of the manner and process of making and using it, in such full, clear, concise, and exact terms as to enable any person skilled in the art to which it pertains, or with which it is most nearly connected, to make and use the same, and shall set forth the best mode contemplated by the inventor of carrying out his invention.

Obviously, if a claimed invention does not have utility, the specification cannot enable one to use it.

As noted, although the examiner and the Board both mentioned § 101, and the rejection appears to be based on the issue of whether the compounds had a practical utility, a § 101 issue, the rejection according to the Board stands on the requirements of § 112 ¶ 1. It is to that provision that we address ourselves. The Board gives two reasons for the rejection; we will consider these in turn.

### 2

The second basis for the Board’s rejection was that, even if the specification did allege a specific use, applicants failed to prove that the claimed compounds are useful. Citing various references, the Board found, and the Commissioner now argues, that the tests offered by the applicants to prove utility were inadequate to convince one of ordinary skill in the art that the claimed compounds are useful as antitumor agents.

This court’s predecessor has stated:

A specification disclosure which contains a teaching of the manner and process of making and using the invention in terms which correspond in scope to those used in describing and defining the subject matter sought to be patented must be taken as in compliance with the enabling requirement of the first paragraph of § 112 unless there is reason to doubt the objective truth of the statements contained therein which must be relied on for enabling support.

*In re Marzocchi*, 439 F.2d 220, 223 (C.C.P.A. 1971). From this it follows that the PTO has the initial burden of challenging a presumptively correct assertion of utility in the disclosure. Only after the PTO provides evidence showing that one of ordinary skill in the art would reasonably doubt the asserted utility does the burden shift to the applicant to provide rebuttal evidence sufficient to convince such a person of the invention’s asserted utility.

The PTO has not met this initial burden. The references cited by the Board, Pazdur and Martin, do not question the usefulness of any compound as an antitumor agent or provide any other evidence to cause one of skill in the art to question the asserted utility

of applicants' compounds. Rather, these references merely discuss the therapeutic predictive value of *in vivo* murine tests—relevant only if applicants must prove the ultimate value in humans of their asserted utility. Likewise, we do not find that the nature of applicants' invention alone would cause one of skill in the art to reasonably doubt the asserted usefulness.

The purpose of treating cancer with chemical compounds does not suggest an inherently unbelievable undertaking or involve implausible scientific principles. Modern science has previously identified numerous successful chemotherapeutic agents. In addition, the prior art, specifically Zee Cheng et al., discloses structurally similar compounds to those claimed by the applicants which have been proven *in vivo* to be effective as chemotherapeutic agents against various tumor models.

Taking these facts—the nature of the invention and the PTO's proffered evidence—into consideration we conclude that one skilled in the art would be without basis to reasonably doubt applicants' asserted utility on its face. The PTO thus has not satisfied its initial burden. Accordingly, applicants should not have been required to substantiate their presumptively correct disclosure to avoid a rejection under the first paragraph of § 112.

We do not rest our decision there, however. Even if one skilled in the art would have reasonably questioned the asserted utility, i.e., even if the PTO met its initial burden thereby shifting the burden to the applicants to offer rebuttal evidence, applicants proffered sufficient evidence to convince one of skill in the art of the asserted utility. In particular, applicants provided through Dr. Kluge's declaration test results showing that several compounds within the scope of the claims exhibited significant antitumor activity against the L1210 standard tumor model *in vivo*. Such evidence alone should have been sufficient to satisfy applicants' burden.

The prior art further supports the conclusion that one skilled in the art would be convinced of the applicants' asserted utility. As previously mentioned, prior art—Zee Cheng et al. and Paull—disclosed structurally similar compounds which were proven *in vivo* against various tumor models to be effective as chemotherapeutic agents. Although it is true that minor changes in chemical compounds can radically alter their effects on the human body, evidence of success in structurally similar compounds is relevant in determining whether one skilled in the art would believe an asserted utility.

The Commissioner counters that such *in vivo* tests in animals are only preclinical tests to determine whether a compound is suitable for processing in the second stage of testing, by which he apparently means *in vivo* testing in humans, and therefore are not reasonably predictive of the success of the claimed compounds for treating cancer in humans. The Commissioner, as did the Board, confuses the requirements under the law for obtaining a

## UTILITY

patent with the requirements for obtaining government approval to market a particular drug for human consumption.

Our court's predecessor has determined that proof of an alleged pharmaceutical property for a compound by statistically significant tests with standard experimental animals is sufficient to establish utility. In concluding that similar *in vivo* tests were adequate proof of utility the court in *In re Krimmel* stated:

We hold as we do because it is our firm conviction that one who has taught the public that a compound exhibits some desirable pharmaceutical property in a standard experimental animal has made a significant and useful contribution to the art, even though it may eventually appear that the compound is without value in the treatment in humans.

*Krimmel*, 292 F.2d 948, 953 (C.C.P.A. 1961). Moreover, NCI apparently believes these tests are statistically significant because it has explicitly recognized both the P388 and L1210 murine tumor models as standard screening tests for determining whether new compounds may be useful as antitumor agents.

In the context of this case the Martin and Pazdur references, on which the Commissioner relies, do not convince us otherwise. Pazdur only questions the reliability of the screening tests against lung cancer; it says nothing regarding other types of tumors. Although the Martin reference does note that some laboratory oncologists are skeptical about the predictive value of *in vivo* murine tumor models for human therapy, Martin recognizes that these tumor models continue to contribute to an increasing human cure rate. In fact, the authors conclude that this perception (i.e. lack of predictive reliability) is not tenable in light of present information.

On the basis of animal studies, and controlled testing in a limited number of humans (referred to as Phase I testing), the Food and Drug Administration may authorize Phase II clinical studies. See 21 U.S.C. § 355(i)(1); 21 C.F.R. § 312.23(a)(5), (a)(8) (1994). Authorization for a Phase II study means that the drug may be administered to a larger number of humans, but still under strictly supervised conditions. The purpose of the Phase II study is to determine primarily the safety of the drug when administered to a larger human population, as well as its potential efficacy under different dosage regimes. See 21 C.F.R. § 312.21(b).

FDA approval, however, is not a prerequisite for finding a compound useful within the meaning of the patent laws. Usefulness in patent law, and in particular in the context of pharmaceutical inventions, necessarily includes the expectation of further research and development. The stage at which an invention in this field becomes useful is well before it is ready to be administered to humans. Were we to require Phase II testing in order to prove utility, the associated costs would prevent many companies from obtaining patent

protection on promising new inventions, thereby eliminating an incentive to pursue, through research and development, potential cures in many crucial areas such as the treatment of cancer.

In view of all the foregoing, we conclude that applicants' disclosure complies with the requirements of 35 U.S.C. § 112 ¶ 1.

...

Reversed.

*In re Fisher*  
421 F.3d 1365 (Fed. Cir. 2005)

MICHEL, Chief Judge.

Dane K. Fisher and Raghunath Lalgudi (collectively "Fisher") appeal from the decision of the U.S. Patent and Trademark Office Board of Patent Appeals and Interferences affirming the examiner's final rejection of the only pending claim of application Serial No. 09/619,643 (the "'643 application"), entitled "Nucleic Acid Molecules and Other Molecules Associated with Plants," as unpatentable for lack of utility under 35 U.S.C. § 101 and lack of enablement under 35 U.S.C. § 112, first paragraph. . . .

I

A

The claimed invention relates to five purified nucleic acid sequences that encode proteins and protein fragments in maize plants. The claimed sequences are commonly referred to as "expressed sequence tags" or "ESTs." Before delving into the specifics of this case, it is important to understand more about the basic principles of molecular genetics and the role of ESTs.

Genes are located on chromosomes in the nucleus of a cell and are made of deoxyribonucleic acid ("DNA"). DNA is composed of two strands of nucleotides in double helix formation. The nucleotides contain one of four bases, adenine ("A"), guanine ("G"), cytosine ("C"), and thymine ("T"), that are linked by hydrogen bonds to form complementary base pairs (i.e., A-T and G-C).

When a gene is expressed in a cell, the relevant double-stranded DNA sequence is transcribed into a single strand of messenger ribonucleic acid ("mRNA"). Messenger RNA contains three of the same bases as DNA (A, G, and C), but contains uracil ("U") instead of thymine. mRNA is released from the nucleus of a cell and used by ribosomes found in the cytoplasm to produce proteins.



## UTILITY

Complementary DNA (“cDNA”) is produced synthetically by reverse transcribing mRNA. cDNA, like naturally occurring DNA, is composed of nucleotides containing the four nitrogenous bases, A, T, G, and C. Scientists routinely compile cDNA into libraries to study the kinds of genes expressed in a certain tissue at a particular point in time. One of the goals of this research is to learn what genes and downstream proteins are expressed in a cell so as to regulate gene expression and control protein synthesis.

An EST is a short nucleotide sequence that represents a fragment of a cDNA clone. It is typically generated by isolating a cDNA clone and sequencing a small number of nucleotides located at the end of one of the two cDNA strands. When an EST is introduced into a sample containing a mixture of DNA, the EST may hybridize with a portion of DNA. Such binding shows that the gene corresponding to the EST was being expressed at the time of mRNA extraction.

Claim 1 of the '643 application recites:

A substantially purified nucleic acid molecule that encodes a maize protein or fragment thereof comprising a nucleic acid sequence selected from the group consisting of SEQ ID NO: 1 through SEQ ID NO: 5.

The ESTs . . . are obtained from cDNA library LIB3115, which was generated from pooled leaf tissue harvested from maize plants . . . grown in the fields at Asgrow research stations. [The ESTs] consist of 429, 423, 365, 411, and 331 nucleotides, respectively. When Fisher filed the '643 application, he claimed ESTs corresponding to genes expressed from the maize pooled leaf tissue at the time of anthesis. Nevertheless, Fisher did not know the precise structure or function of either the genes or the proteins encoded for by those genes.

The '643 application generally discloses that the five claimed ESTs may be used in a variety of ways, including: (1) serving as a molecular marker for mapping the entire maize genome, which consists of ten chromosomes that collectively encompass roughly 50,000 genes; (2) measuring the level of mRNA in a tissue sample via microarray technology to provide information about gene expression; (3) providing a source for primers for use in the polymerase chain reaction (“PCR”) process to enable rapid and inexpensive duplication of specific genes; (4) identifying the presence or absence of a polymorphism; (5) isolating promoters via chromosome walking; (6) controlling protein expression; and (7) locating genetic molecules of other plants and organisms.

...

[The examiner rejected claim 1 for lack of utility and found that the claimed ESTs were not supported by a specific and substantial utility. The Board affirmed the rejection for lack of utility under § 101 and lack of enablement under § 112. This appeal followed.]

## CHAPTER 4

### II

Whether an application discloses a utility for a claimed invention is a question of fact. We consequently review the Board's determination that the '643 application failed to satisfy the utility requirement of § 101 for substantial evidence.

### A

We agree with both the government and the amici that none of Fisher's seven asserted uses meets the utility requirement of § 101. In *Brenner*, the Supreme Court . . . announced a more rigorous test [than *Lowell*], stating:

The basic quid pro quo contemplated by the Constitution and the Congress for granting a patent monopoly is the benefit derived by the public from an invention with substantial utility. Unless and until a process is refined and developed to this point—where specific benefit exists in currently available form—there is insufficient justification for permitting an applicant to engross what may prove to be a broad field.

Following *Brenner*, our predecessor court, the Court of Customs and Patent Appeals, and this court have required a claimed invention to have a specific and substantial utility to satisfy § 101.

The Supreme Court has not defined what the terms "specific" and "substantial" mean per se. Nevertheless, together with the Court of Customs and Patent Appeals, we have offered guidance as to the uses which would meet the utility standard of § 101. From this, we can discern the kind of disclosure an application must contain to establish a specific and substantial utility for the claimed invention.

Courts have used the labels "practical utility" and "real world" utility interchangeably in determining whether an invention offers a "substantial" utility. Indeed, the Court of Customs and Patent Appeals stated that "'practical utility' is a shorthand way of attributing 'real-world' value to claimed subject matter. In other words, one skilled in the art can use a claimed discovery in a manner which provides some immediate benefit to the public." *Nelson*, 626 F.2d at 856. It thus is clear that an application must show that an invention is useful to the public as disclosed in its current form, not that it may prove useful at some future date after further research. Simply put, to satisfy the "substantial" utility requirement, an asserted use must show that that claimed invention has a significant and presently available benefit to the public.

Turning to the "specific" utility requirement, an application must disclose a use which is not so vague as to be meaningless. . . . Thus, in addition to providing a "substantial" utility, an asserted use must also show that that claimed invention can be used to provide a well-defined and particular benefit to the public.

## UTILITY

In 2001, partially in response to questions about the patentability of ESTs, the PTO issued Utility Guidelines governing its internal practice for determining whether a claimed invention satisfies § 101. *See* Utility Examination Guidelines, 66 Fed. Reg. 1092 (Jan. 5, 2001). The PTO incorporated these guidelines into the Manual of Patent Examining Procedure (“MPEP”). The MPEP and Guidelines “are not binding on this court, but may be given judicial notice to the extent they do not conflict with the statute.” *Enzo Biochem v. Gen-Probe*, 323 F.3d 956, 964 (Fed. Cir. 2002). According to the Utility Guidelines, a specific utility is particular to the subject matter claimed and would not be applicable to a broad class of invention. Manual of Patent Examining Procedure § 2107.01. The Utility Guidelines also explain that a substantial utility defines a “real world” use. In particular, “utilities that require or constitute carrying out further research to identify or reasonably confirm a ‘real world’ context of use are not substantial utilities.” *Id.* Further, the Utility Guidelines discuss “research tools,” a term often given to inventions used to conduct research. The PTO particularly cautions that

an assessment that focuses on whether an invention is useful only in a research setting thus does not address whether the invention is in fact “useful” in a patent sense. The PTO must distinguish between inventions that have a specifically identified substantial utility and inventions whose asserted utility requires further research to identify or reasonably confirm.

The PTO’s standards for assessing whether a claimed invention has a specific and substantial utility comport with this court’s interpretation of the utility requirement of § 101.

Turning to the parties’ arguments, Fisher first raises a legal issue, charging that the Board applied a heightened standard for utility in the case of ESTs. Fisher apparently bases this argument on statements made by the Board in connection with its discussion of whether the claimed ESTs can be used to identify a polymorphism. In that context, the Board stated:

Somewhere between having no knowledge (the present circumstances) and having complete knowledge of the gene and its role in the plant’s development lies the line between “utility” and “substantial utility.” We need not draw the line or further define it in this case because the facts in this case represent the lowest end of the spectrum, i.e., an insubstantial use.

Fisher reads the word “spectrum” out of context, claiming that the word somehow implies the application of a higher standard for utility than required by § 101. We conclude, however, that the Board did not apply an incorrect legal standard. In its decision, the Board made reference to a “spectrum” to differentiate between a substantial utility, which satisfies the utility requirement of § 101, and an insubstantial utility, which fails to satisfy

§ 101. The Board plainly did not announce or apply a new test for assessing the utility of ESTs. It simply followed the Utility Guidelines and MPEP, which mandate the specific and substantial utility test set forth in *Brenner*. Indeed, we note that Example 9 of the PTO's "Revised Interim Utility Guidelines Training Materials" is applicable to the facts here. In that example, a cDNA fragment disclosed as being useful as a probe to obtain the full length gene corresponding to a cDNA fragment was deemed to lack a specific and substantial utility. Additionally, the MPEP particularly explains that a claim directed to a polynucleotide disclosed to be useful as a "gene probe" or "chromosome marker," as is the case here, fails to satisfy the specific utility requirement unless a specific DNA target is also disclosed. MPEP § 2107.01.

Regarding the seven uses asserted by Fisher, we observe that each claimed EST uniquely corresponds to the single gene from which it was transcribed ("underlying gene"). As of the filing date of the '643 application, Fisher admits that the underlying genes have no known functions. Fisher, nevertheless, claims that this fact is irrelevant because the seven asserted uses are not related to the functions of the underlying genes. We are not convinced by this contention. Essentially, the claimed ESTs act as no more than research intermediates that may help scientists to isolate the particular underlying protein-encoding genes and conduct further experimentation on those genes. The overall goal of such experimentation is presumably to understand the maize genome—the functions of the underlying genes, the identity of the encoded proteins, the role those proteins play during anthesis, whether polymorphisms exist, the identity of promoters that trigger protein expression, whether protein expression may be controlled, etc. Accordingly, the claimed ESTs are, in words of the Supreme Court, mere "objects of use-testing," to wit, objects upon which scientific research could be performed with no assurance that anything useful will be discovered in the end. *Brenner*, 383 U.S. at 535.

Fisher compares the claimed ESTs to certain other patentable research tools, such as a microscope. Although this comparison may, on first blush, be appealing in that both a microscope and one of the claimed ESTs can be used to generate scientific data about a sample having unknown properties, Fisher's analogy is flawed. As the government points out, a microscope has the specific benefit of optically magnifying an object to immediately reveal its structure. One of the claimed ESTs, by contrast, can only be used to detect the presence of genetic material having the same structure as the EST itself. It is unable to provide any information about the overall structure let alone the function of the underlying gene. Accordingly, while a microscope can offer an immediate, real world benefit in a variety of applications, the same cannot be said for the claimed ESTs. Fisher's proposed analogy is thus inapt. Hence, we conclude that Fisher's asserted uses are insufficient to meet the standard for a "substantial" utility under § 101.

## UTILITY

Moreover, all of Fisher's asserted uses represent merely hypothetical possibilities, objectives which the claimed ESTs, or any EST for that matter, could possibly achieve, but none for which they have been used in the real world. Focusing on the two uses emphasized by Fisher at oral argument, Fisher maintains that the claimed ESTs could be used to identify polymorphisms or to isolate promoters. Nevertheless, in the face of a utility rejection, Fisher has not presented any evidence, as the Board well noted, showing that the claimed ESTs have been used in either way. . . . Further, Fisher has not shown that a polymorphism or promoter so identified would have a "specific and substantial" use. The Board, in fact, correctly recognized this very deficiency and cited it as one of the reasons for upholding the examiner's final rejection.

With respect to the remaining asserted uses, there is no disclosure in the specification showing that any of the claimed ESTs were used as a molecular marker on a map of the maize genome. There also is no disclosure establishing that any of the claimed ESTs were used or, for that matter, could be used to control or provide information about gene expression. . . . Consequently, because Fisher failed to prove that its claimed ESTs can be successfully used in the seven ways disclosed in the '643 application, we have no choice but to conclude that the claimed ESTs do not have a "substantial" utility under § 101.

Furthermore, Fisher's seven asserted uses are plainly not "specific." Any EST transcribed from any gene in the maize genome has the potential to perform any one of the alleged uses. . . .

We agree with the Board that the facts here are similar to those in *Brenner*. . . . The *Brenner* court held that the claimed process lacked a utility because it could be used only to produce a compound of unknown use. The *Brenner* court stated: "We find absolutely no warrant for the proposition that although Congress intended that no patent be granted on a chemical compound whose sole 'utility' consists of its potential role as an object of use-testing, a different set of rules was meant to apply to the process which yielded the unpatentable product." 383 U.S. at 535. Applying that same logic here, we conclude that the claimed ESTs, which do not correlate to an underlying gene of known function, fail to meet the standard for utility intended by Congress.

. . .

. . . In *Brenner*, the Supreme Court was primarily concerned with creating an unwarranted monopoly to the detriment of the public:

Whatever weight is attached to the value of encouraging disclosure and of inhibiting secrecy, we believe a more compelling consideration is that a process patent in the chemical field, which has not been developed and pointed to the degree of specific utility, creates a monopoly of knowledge which should be granted only if clearly commanded by the statute. Until the process claim has been

reduced to production of a product shown to be useful, the metes and bounds of that monopoly are not capable of precise delineation. It may engross a vast, unknown, and perhaps unknowable area. Such a patent may confer power to block off whole areas of scientific development, without compensating benefit to the public. This is not to say that we mean to disparage the importance of contributions to the fund of scientific information short of the invention of something “useful,” or that we are blind to the prospect that what now seems without “use” may tomorrow command the grateful attention of the public. But a patent is not a hunting license. It is not a reward for the search, but compensation for its successful conclusion. . . .

Here, granting a patent to Fisher for its five claimed ESTs would amount to a hunting license because the claimed ESTs can be used only to gain further information about the underlying genes and the proteins encoded for by those genes. The claimed ESTs themselves are not an end of Fisher’s research effort, but only tools to be used along the way in the search for a practical utility.

. . .

As a final matter, we observe that the government and its amici express concern that allowing EST patents without proof of utility would discourage research, delay scientific discovery, and thwart progress in the “useful Arts” and “Science.” *See* U.S. Const. art. I, § 8, cl. 8. The government and its amici point out that allowing EST claims like Fisher’s would give rise to multiple patents, likely owned by several different companies, relating to the same underlying gene and expressed protein. Such a situation, the government and amici predict, would result in an unnecessarily convoluted licensing environment for those interested in researching that gene and/or protein.

The concerns of the government and amici, which may or may not be valid, are not ones that should be considered in deciding whether the application for the claimed ESTs meets the utility requirement of § 101. They are public policy considerations which are more appropriately directed to Congress as the legislative branch of government, rather than this court as a judicial body responsible simply for interpreting and applying statutory law. . . . Policy reasons aside, because we conclude that the utility requirement of § 101 is not met, we hold that Fisher is not entitled to a patent for the five claimed ESTs.

. . .

RADER, Circuit Judge, dissenting.

This court today determines that expressed sequence tags (ESTs) do not satisfy 35 U.S.C. § 101 unless there is a known use for the genes from which each EST is transcribed. While I agree that an invention must demonstrate utility to satisfy § 101, these claimed

## UTILITY

ESTs have such a utility, at least as research tools in isolating and studying other molecules. Therefore, I respectfully dissent.

Several, if not all, of Fisher's asserted utilities claim that ESTs function to study other molecules. In simple terms, ESTs are research tools. Admittedly ESTs have use only in a research setting. However, the value and utility of research tools generally is beyond question, even though limited to a laboratory setting. . . . These research tools are similar to a microscope; both take a researcher one step closer to identifying and understanding a previously unknown and invisible structure. Both supply information about a molecular structure. Both advance research and bring scientists closer to unlocking the secrets of the corn genome to provide better food production for the hungry world. If a microscope has § 101 utility, so too do these ESTs.

...

In truth, I have some sympathy with the Patent Office's dilemma. The Office needs some tool to reject inventions that may advance the "useful arts" but not sufficiently to warrant the valuable exclusive right of a patent. The Patent Office has seized upon this utility requirement to reject these research tools as contributing "insubstantially" to the advance of the useful arts. The utility requirement is ill suited to that task, however, because it lacks any standard for assessing the state of the prior art and the contributions of the claimed advance. The proper tool for assessing sufficient contribution to the useful arts is the obviousness requirement of 35 U.S.C. § 103. . . .

### Context & Application

1. How do *Fisher* and *Brana* differ? Can their holdings be reconciled? The rejection in *In re Brana* was based on a failure to meet the requirements of § 112, whereas the rejection in *In re Fisher* was based on the requirements of § 101. Is there a difference between the utility requirements of the two statutory sections? If so, how do those requirements differ?

2. In dissent in *In re Fisher*, Judge Rader suggests that nonobviousness is the better standard by which to reject inventions that do not sufficiently contribute to the useful arts. Note that in *In re Brana*, the Examiner rejected on both utility and obviousness grounds, but the Board affirmed solely on the basis of the utility ruling. Keep these cases in mind as you read the materials on the § 103 nonobviousness requirement. Consider whether that doctrine is better suited to the line the court is trying to draw.





## 5. DISCLOSURE

To get a patent, you have to publicly disclose certain information about your invention. Why might we want to require such disclosures? Why might a patent applicant not want to provide them? As we begin to explore these questions, consider the famous case of *O'Reilly v. Morse*, 56 U.S. 62 (1853). According to the record before the Court, “the first fact of electro-magnetism was discovered” in the winter of 1819–1820. At that point, scientists around the world recognized “that this newly-discovered power might be used to communicate intelligence to distant places” but they struggled with how, exactly, to do so. In 1832, Samuel Morse, a painter, turned his attention to that problem. He eventually developed a working telegraph. But when he tried to enforce his patent in court, the accused infringers argued that the patent was too broad. Specifically, they attacked claim eight, which stated:

I do not propose to limit myself to the specific machinery or parts of machinery described in the foregoing specification and claims; the essence of my invention being the use of the motive power of the electric or galvanic current, which I call electro-magnetism, however developed, for marking or printing intelligible characters, signs, or letters, at any distances, being a new application of that power of which I claim to be the first inventor or discoverer.

Thus, Morse claimed “the exclusive right to every improvement where the motive power is the electric or galvanic current, and the result is the marking or printing intelligible characters, signs, or letters at a distance.” The Court ruled that while Morse was entitled to a patent on the actual method or process or machine that he discovered or invented, he was not entitled to a patent that covered all future variations on that theme. The Court expressed concern that:

[S]ome future inventor, in the onward march of science, may discover a mode of writing or printing at a distance by means of the electric or galvanic current, without using any part of the process or combination set forth in the plaintiff's specification. His invention may be less complicated—less liable to get out of order—less expensive in construction, and in its operation. But yet if it is covered by this patent the inventor could not use it, nor the public have the benefit of it without the permission of this patentee.

Nor is this all, while he shuts the door against inventions of other persons, the patentee would be able to avail himself of new discoveries in the properties and powers of electro-magnetism which scientific men might bring to light. . . . New

discoveries in physical science may enable him to combine it with new agents and new elements, and by that means attain the object in a manner superior to the present process and altogether different from it. And if he can secure the exclusive use by his present patent he may vary it with every new discovery and development of the science, and need place no description of the new manner, process, or machinery, upon the records of the patent office. . . . The court is of opinion that the claim is too broad, and not warranted by law.

Under the Patent Act of 1836, which the Supreme Court applied in *Morse*, the specification had to disclose “the manner and process of making, constructing, using, and compounding” the invention, “in such exact terms as to enable any person skilled in the art or science to which it appertains, or with which it is most nearly connected, to make, construct, compound, and use the same.” See *Morse*, 56 U.S. at 118. The current Patent Act contains similar language:

The specification shall contain a written description of the invention, and of the manner and process of making and using it, in such full, clear, concise, and exact terms as to enable any person skilled in the art to which it pertains, or with which it is most nearly connected, to make and use the same, and shall set forth the best mode contemplated by the inventor or joint inventor of carrying out the invention.

35 U.S.C. § 112(a). It also states that: “The specification shall conclude with one or more claims particularly pointing out and distinctly claiming the subject matter which the inventor or a joint inventor regards as the invention.” *Id.* § 112(b). Courts have read these provisions of § 112 as creating four distinct requirements for patentability: (1) enablement; (2) written description; (3) definiteness; and (4) best mode. Together, these requirements are often referred to as the “disclosure doctrines.” This Chapter will discuss them in turn.

Before we begin, a quick note on terminology: Prior to the enactment of the AIA, § 112 did not have defined subsections. So you may read (or hear) people say “section 112, first paragraph” or “section 112, ¶ 1” when referring to enablement, written description, and best mode. Similarly, you may see “section 112, second paragraph” or “section 112, ¶ 2” when referring to definiteness. The AIA assigned letters to the subsections of section 112; post-AIA cases accordingly refer to section 112(a), section 112(b), and so on. But the main substance of these provisions has not changed.

## A. Enablement

Under § 112(a), the specification must describe “the manner and process of making and using” the invention “in such full, clear, concise, and exact terms as to *enable* any

## DISCLOSURE

person skilled in the art to which it pertains, or with which it is most nearly connected, to make and use the same.” (emphasis added) We call this the requirement of “enablement.”

*CFMT, Inc. v. YieldUp Int’l Corp.*  
349 F.3d 1333 (Fed. Cir. 2003)

RADER, Circuit Judge.

On summary judgment, the United States District Court for the District of Delaware determined that CFMT, Inc.’s U.S. Patent No. 4,778,532 (the ‘532 patent) and U.S. Patent No. 4,917,123 (the ‘123 patent) are invalid . . . . [T]his court reverses-in-part, vacates-in-part, and remands.

### I

The ‘532 and ‘123 patents cover a system for cleaning semiconductor wafers. The process for manufacturing semiconductor wafers must keep them as free as possible from contamination to prevent defects in semiconductors. To keep the wafers clean, conventional processes sequentially immerse the wafers in various liquids in an open environment. This bathing procedure exposes the wafers to airborne contaminants and also exposes workers to hazardous chemicals.

The ‘532 and ‘123 patents claim improvements in these open cleaning systems. Specifically, the ‘532 and ‘123 patents claim a system that is closed to the outside environment and requires no human handling. Instead the wafers remain at all times in a closed container that sequentially introduces different chemicals to clean the wafers. Because the ‘123 patent is a divisional of the ‘532 patent, the two patents have identical disclosures. The parent ‘532 patent contains method claims only. Independent claim[] 1 . . . [is] representative:

1. An enclosed, full flow method for the cleaning of semiconductor wafers comprising positioning said wafers in a vessel, closing said vessel to the environment, and flowing process fluids sequentially and continuously past said wafers in said vessel, including the steps of

(a) contacting said wafers with at least one cleaning fluid to remove contaminants from said wafers;

(b) removing said cleaning fluid from said wafers with a rinsing fluid; and

(c) removing said rinsing fluid from said wafers with a drying fluid;

whereby the processing does not require (sic) movement or operator handling of said wafers between said steps; and

maintaining the vessel containing said wafers hydraulically full during each process step.

...

The divisional '123 patent contains corresponding apparatus claims. Independent claim[] 1 . . . [is] representative:

1. Apparatus for wet processing of semiconductor wafers comprising:

(a) vessel means for supporting said wafers in a closed circulation process stream wherein process fluids may sequentially flow past said wafers, said vessel being hydraulically full with process fluid when said process fluids flow past said wafers;

(b) means for supplying at least one cleaning fluid to said process stream for removing contaminants from said wafers, and means for withdrawing said cleaning fluid from said process stream;

(c) means for supplying a rinsing fluid to said process stream for removing other fluids from said wafers, means for minimizing gas/liquid interfaces in said rinsing fluid and means for withdrawing said rinsing fluid from said process stream; and

(d) means for supplying a drying fluid to said process stream for removing other fluids from said wafers and means for withdrawing said drying fluid from said process stream.

...

The record in this case shows that the inventors installed for Texas Instruments (TI) a machine that performed the claimed method. At first the apparatus did not meet this customer's standards for wafer cleanliness. The inventors adjusted the apparatus and experimented for months before meeting the customer's standards. In fact, the inventors obtained a third patent claiming the improvements in their initial apparatus.

CFMT and CFM Technologies, Inc. (collectively CFMT) sued YieldUp International Corp. (YieldUp) for infringement of the '532 and '123 patents. . . .

## I

YieldUp based its nonenablement argument on problems CFMT faced in setting up a commercial embodiment of the invention, the "beta tool Full Flow" machine. As noted before, CFMT had installed the Full Flow machine at a TI site. In its first runs, the machine did not meet TI's cleanliness standards. After months of experiments, the inventors identified the problem in a drying step and solved it. Concurrently, a patent application that led to the '532 patent was pending before the PTO. While prosecuting the application,

## DISCLOSURE

CFMT submitted a list of advantages of the invention to the PTO, but did not tell the PTO of the problems at TI. The examiner allowed the case and the '532 patent issued. As also noted, the inventors eventually filed a patent application on the improvement that solved the problem. That application matured into U.S. Patent No. 4,911,761 (the '761 patent).

[T]he district court granted YieldUp's motion for summary judgment that the '532 and '123 patents were invalid for nonenablement. . . .

### II

Enablement is a question of law with factual underpinnings; this court reviews the ultimate legal conclusion without deference. . . .

### A

The district court based its nonenablement judgment on two grounds: (1) lack of utility or inoperability and (2) undue experimentation needed to carry out the invention. The district court first construed each of the preamble terms "cleaning," "treatment," and "wet processing" as requiring "removal of contaminants." Based on that construction, the district court concluded that "the claims of the '532 and '123 patents must enable one skilled in the art to clean semiconductor wafers using the Full Flow system." The district court considered that "the first wafers processed with the Full Flow system appeared clean to the naked eye" but looked "filthy" viewed using laser scanning. The district court concluded that the TI data showed that the claimed system did not remove particles until the inventors developed the improvements leading to the '761 patent. The district court found that "the Full Flow system that was based on the '532 and '123 patents could not clean semiconductor wafers." The district court considered that the inventors experimented "for more than six months" making "hundreds of modifications." The district court concluded that the "fact that the solution to the problem eventually resulted in the '761 patent demonstrates that the experimentation required to enable the '532 and '123 patents was not routine."

The parties do not challenge the district court's construction . . . . The parties also do not dispute that the record shows CFMT's initial efforts to build the claimed apparatus and to carry out the individual steps of the claimed method required undue experimentation. Instead, this case asks this court to examine whether these claims required a specific level of contaminant removal that the disclosure did not enable. Further, this court must consider whether the improvements in the '761 patent show that the '532 and '123 patents did not enable the scope of those claimed inventions.

At the outset, the district court erred in requiring that the patent disclosures enable a single embodiment, the Full Flow system, to meet TI's commercial standards. In essence, the district court set the enablement bar too high. Enablement does not require an inventor

to meet lofty standards for success in the commercial marketplace. Title 35 does not require that a patent disclosure enable one of ordinary skill in the art to make and use a perfected, commercially viable embodiment absent a claim limitation to that effect.

Title 35 requires only that the inventor enable one of skill in the art to make and use the full scope of the claimed invention. Thus, when an invention claims a general system to improve the cleaning process for semiconductor wafers, the disclosure enables that invention by showing improvements in the overall system. Of course, if a patent claimed a system that achieved cleanliness up to a specified numerical particle-free range, then enablement would require disclosure of a method that enables one of ordinary skill to achieve that range without undue experimentation. Thus, the level of disclosure necessary to satisfy section 112 of title 35 varies according to the scope of the claimed invention.

The claims of the '532 and '123 patents state no standard of cleaning. As the district court correctly found, "cleaning" in the context of this invention means generally removing contaminants from the wafer surface. Absent some standard for cleanliness in the claims, this court proceeds to examine the record for a showing that the disclosures of the CFMT patents would enable a person of skill in the art to make and use a system or apparatus to achieve any level of contaminant removal without undue experimentation.

The record contains evidence that the inventors' prototype removed grease stains. The inventors testified that before setting up the TI apparatus, they verified by naked eye that a prototype of the invention removed penciled grease marks. This record evidence is probative of whether the "removal of contaminants" limitation is enabled. This court also notes that the record contains no evidence that a person of ordinary skill would have to undertake undue experimentation to build a similar prototype and carry out the claimed method to remove the contaminants—in this instance, grease marks.

The lengthy experiments at TI do not show nonenablement because the inventors undertook that work to satisfy TI's particular commercial requirements, not to show enablement of the scope of the claimed inventions. "Patents are not production documents, and nothing in the patent law requires that a patentee must disclose data on how to mass-produce the invented product. The law requires that patents disclose inventions, not mass-production data, and that patents enable the practice of inventions, not the organization and operation of factories." Reliance on the TI data alone also betrays another error, namely that this court gauges enablement at the date of the filing, not in light of later developments.

...

Because the preamble term "cleaning" means only "removal of contaminants," not removal of all contaminants or removal of contaminants according to the TI commercial standard, the inventor shows utility and enables the invention by disclosing "removal of

## DISCLOSURE

contaminants.” . . . In this case, with its specific claims and invention, the specification needed to teach one of ordinary skill to make and use a system or apparatus that removes any contaminants. In sum, any meaningful “cleaning” would satisfy the claimed goal of “cleaning of semiconductor wafers.”

The district court’s second ground for nonenablement invoked the ’761 improvement patent as evidence that the inventors engaged in undue experimentation to “clean” semiconductor wafers. The district court reasoned that the inventor had not enabled the ’532 and ’123 patents because only the further invention of the ’761 improvement patent sufficed to meet TI’s commercial standard.

Improvement and selection inventions are ubiquitous in patent law; such developments do not alone cast doubt on enablement of the original invention. In general, few patented inventions are an immediate commercial success. Rather, most inventions require further development to achieve commercial success. Thus, additional inventive work does not alone show nonenablement.

Moreover, the district court’s reasoning presumes incorrectly that development of an improvement patent, the ’761 in this case, implies extensive experimentation. To the contrary, patent acquisition does not require any threshold level of effort or ingenuity. Thus, the ’761 improvement patent alone is not conclusive evidence of undue experimentation.

Because the district court misapplied the law of enablement in concluding that the claims of the ’532 and ’123 patents are invalid, this court vacates that part of the decision. . . . The district court may decide, under the correct legal standard, whether to grant CFMT’s cross-motion for summary judgment of enablement or whether to proceed to trial on that issue. . . . This court therefore reverses-in-part, vacates-in-part, and remands.

### Context & Application

1. What is the purpose (or purposes) of the enablement requirement? In other words, why do we make inventors disclose how to make and use their inventions?
2. Many people consider *Morse* an enablement case. Now that you know more about the current approach to enablement, do you agree? What other doctrines might *Morse* be based on?
3. In practice, analyzing enablement issues can be technically complicated. But the core concept is simple. Imagine that you are writing a recipe for making enchiladas. You might safely assume that anyone using your recipe knows how to put a liquid in a pot and “bring it to a boil.” But what if you tell them to “fold in the cheese”? Will your readers know how to do that? The answer depends on how much experience your anticipated

readers have with cooking. Those with limited cooking experience may struggle if you just say “fold in the cheese.” But if you’re writing a cookbook aimed at more experienced cooks, you might not need to explain. Of course, a patent is not a recipe (or, as we learned in *CFMT*, a “production document”). But the basic principle is the same; the amount of explanation needed depends on the level of knowledge and skill we’d expect the readers to have.

4. In *CFMT*, the court says that “Title 35 requires only that the inventor enable one of skill in the art to make and use the full scope of the claimed invention.” Where does the court look to determine what constitutes “the claimed invention”?

5. In *CFMT*, the court mentioned that the parties did not appeal the district judge’s “construction” —i.e., the interpretation of the key claim terms. *See* Chapter 8. As you read these cases, notice how claim construction and invalidity are intertwined. When you’re making arguments about what a claim term means, you have to think about whether the claim will cover the accused product while also paying attention to whether a certain construction will create validity problems. We’ll see this again in the next case.

*McRO, Inc. v. Bandai Namco Games Am. Inc.*  
959 F.3d 1091 (Fed. Cir. 2020)

TARANTO, Circuit Judge.

McRO, Inc., d/b/a Planet Blue brought this case against more than a dozen video game developers (the Developers), alleging that the Developers infringed . . . U.S. Patent No. 6,611,278, owned by McRO. The district court held the claims invalid for ineligibility under 35 U.S.C. § 101, but we reversed that holding in *McRO, Inc. v. Bandai Namco Games America Inc.*, 837 F.3d 1299 (Fed. Cir. 2016) (*McRO I*). On remand, the district court ultimately held that the Developers were entitled . . . to summary judgment of invalidity because the specification fails to enable the full scope of the claims.

McRO appeals. We affirm the judgment of noninfringement. We vacate the judgment of invalidity and remand for the district court to consider any appropriate further proceedings . . . .

I

A

McRO asserts claims 1, 4, and 13 of its patent. Claim 1 is representative for purposes of the issues on appeal:

1. A method for automatically animating lip synchronization and facial expression of three-dimensional characters comprising:



## DISCLOSURE

obtaining a first set of rules that defines a morph weight set stream as a function of phoneme sequence and times associated with said phoneme sequence;

obtaining a plurality of sub-sequences of timed phonemes corresponding to a desired audio sequence for said three-dimensional characters;

generating an output morph weight set stream by applying said first set of rules to each sub-sequence of said plurality of sub-sequences of timed phonemes; and

applying said output morph weight set stream to an input sequence of animated characters to generate an output sequence of animated characters with lip and facial expression synchronized to said audio sequence.

### B

In 2012, McRO sued the Developers for patent infringement based on the Developers' production and sale of video games that used one of two third-party software applications—FaceFX or Annosoft—to model facial animations. . . .

[The Federal Circuit reversed the district court's judgment on the pleadings holding the claims invalid under 35 U.S.C. § 101. On remand, the district court noted that the Developers had identified two animation techniques—bones animation and the "BALDI system"—that are not enabled by the specification but were practiced by the accused infringers. The court concluded that the Developers had provided clear and convincing evidence that "at the time of the invention, a person of skill in the art would not have the tools to practice the full scope of the 'first set of rules' limitation."]

### II

[W]hether a patent satisfies the enablement requirement is a question of law based on underlying factual findings. The party challenging the validity of the patent must provide clear and convincing evidence to support such factual findings.

### B

We now address McRO's appeal of the judgment of invalidity based on the specification's failure to enable the full scope of claim 1's required "first set of rules." We agree with McRO that the Developers failed to identify with particularity any method of animation that falls within the scope of claim 1 and is not enabled. Without any specific examples, the district court's reasoning is too abstract, too conclusory, to support summary judgment. We do not go so far as to hold that there is a triable issue of fact on enablement—instead, we vacate the judgment and remand for the district court to consider how to proceed.

The requirement of enablement, stated in 35 U.S.C. § 112, enforces the essential “*quid pro quo* of the patent bargain” by requiring a patentee to teach the public how “to practice the full scope of the claimed invention.” . . . Although a patent’s specification need not “describe how to make and use every possible variant of the claimed invention,” “when a range is claimed, there must be reasonable enablement of the scope of the range.” To qualify as “reasonable,” “the specification must teach those skilled in the art how to make and use the full scope of the claimed invention without ‘undue experimentation.’”

This statutory requirement is limited to what is claimed. Section 112 requires enablement of “only the claimed invention,” not matter outside the claims. For that reason, the “enablement inquiry necessarily depends on an interpretation of the claims.”

Once the precise scope of the claimed invention is defined, the question is whether undue experimentation is required to make and use the full scope of embodiments of the invention claimed. Whether undue experimentation is required “is not a single, simple factual determination, but rather is a conclusion reached by weighing many factual considerations.” *ALZA*, 603 F.3d at 940 (citing *In re Wands*, 858 F.2d 731, 737 (Fed. Cir. 1988)). Conducting the *Wands* analysis has routinely involved concrete identification of at least some embodiment or embodiments asserted not to be enabled—including what particular products or processes are or may be within the claim, so that breadth is shown concretely and not just as an abstract possibility, and how much experimentation a skilled artisan would have to undertake to make and use those products or processes.

All the enablement cases on which the district court relied, and on which the Developers rely in this court, involved specific identification of products or processes that were or may be within the scope of the claims and were allegedly not enabled. In *Automotive Technologies International, Inc. v. BMW of North America*, for example, we considered whether a claimed “side impact crash sensor for a vehicle having front and rear wheels” was enabled. 501 F.3d 1274, 1277 (Fed. Cir. 2007). We observed that, under the governing claim construction (not disputed by the parties), the claim term embraced “electronic side impact sensors.” The enablement question, then, was a concrete one: whether the “specification did not enable the full scope of the invention because it did not enable electronic side impact sensors.”

. . . In *Sitrick v. Dreamworks, LLC*, 516 F.3d 993, 999–1001 (Fed. Cir. 2008), the claim covered both video games and movies, and it was movies that the court held to be not enabled. . . . In *Trustees of Boston University v. Everlight Electronics Co. Ltd.*, 896 F.3d 1357, 1360, 1362 (Fed. Cir. 2018), the parties agreed that the claim covered six permutations for the relationship between a growth layer and a buffer layer, and it was one of those permutations that the court concluded was not enabled.

## DISCLOSURE

In short, none of the cases invoked by the district court and by the Developers have involved an abstract assertion of breadth, without concrete identification of matter that is not enabled but is or may be within the claim scope. As next explained, this case, in its current posture, involves such an abstract assertion of breadth. Under our claim construction, the bones and BALDI techniques are noninfringing and so cannot support a nonenablement determination. And no other concretely identified animation techniques have been advanced to support the district court's and Developers' enablement analyses.

### 2

The district court in this case determined that the specification of the '278 patent fails to enable claim 1's "first set of rules" limitation. Specifically, claim 1 requires "obtaining a first set of rules that defines a morph weight set stream as a function of phoneme sequence and times associated with said phoneme sequence." This claim, the specification reveals, requires at least two operations.

First, the specification makes clear that obtaining the set of rules presupposes identifying which mouth shapes (morph targets) should be used for representing a particular phoneme (or phoneme sequence) appearing on the "time aligned phonetic transcription" that is being synched to an animation. For example, the specification explains, an artist would have to know that "the 'l' in 'hello'" requires a wider mouth shape than the "'l' in 'burly.'"

But on the record before us, this aspect of the claimed rules need not have been taught in the specification, and the district court did not rule otherwise. An "artisan's knowledge of the prior art and routine experimentation can often fill gaps, interpolate between embodiments, and perhaps even extrapolate beyond the disclosed embodiments, depending upon the predictability of the art" and a "patent need not teach, and preferably omits, what is well known in the art." Here, the district court explained that "both experts apparently agree that the state of computer animation overall and the development of rules for animation was well-developed in other contexts." The specification itself indicates that animators knew how to match mouth positions to phonemes—doing so just took a significant amount of time because the process was manual. The inventors here do not purport to have discovered that the "l" in "hello" requires a wider mouth shape than the "l" in "burly."

The second, and assertedly novel, aspect of the invention, is a set of rules that tells the system how to automatically output the chosen mouth shapes in a format that can create an animation—as a continuous stream of morph weight sets that can transform a neutral model. Because this process is the novel aspect of the claimed invention, the specification must reasonably teach how to make and use this aspect of the invention.

The Developers have not, at this point in the case, met their burden of identifying a set of rules, for automatically outputting chosen mouth shapes, that is or may be within the scope of claim 1.

The district court identified, and relied on for the “more important” part of its analysis, two specific examples offered by Dr. Wyvill (the Developers’ expert): bones animation (the accused product) and the BALDI system. . . .

Given our construction of the term “morph weight sets,” however, both bones animation and the BALDI system are clearly “outside the scope of the claims” and are thus “irrelevant to enablement.” With respect to bones animation, our noninfringement decision compels this conclusion—“bones” are not, and do not use, three-dimensional geometric vectors to move vertices. Record evidence compels the same conclusion with respect to the BALDI process, at least in the context of a summary-judgment motion. Dr. Wyvill, in the context of an expert opinion regarding obviousness, conceded that BALDI’s “parameter target values corresponding to each phoneme do not represent delta sets as construed” and that BALDI’s equations “do not represent the displacements of each vertex in terms of a simple xyz displacement vector.”

Without bones animation and the BALDI process available as claim-covered techniques that must be enabled, the district court’s reasoning is too abstract and too conclusory to support summary judgment.

...

We see no reason in this case to depart from our usual requirement that the challenger identify specifics that are or may be within the claim but are not enabled. Specifics have always mattered. Here, a “fuller set of fact-findings about what is within the scope of the claims” is necessary “to decide the enablement issue.”

### III

We affirm the district court’s judgment that the Developers did not infringe the ’278 patent. We vacate the district court’s judgment that the Developers were entitled to summary judgment that the ’278 patent is invalid for lack of enablement. Without holding that the Developers could not make such a showing, we remand the case for such further proceedings as are appropriate . . . .

## Context &amp; Application

1. In *McRO*, the court says that enablement “enforces the essential *quid pro quo* of the patent bargain by requiring a patentee to teach the public how to practice the full scope of the claimed invention.” What does the court mean by “the public” here?

2. In *McRO*, the court talks about enabling “the full scope” of the invention. How does the court determine what constitutes “the claimed invention”? And how “full” does full-scope enablement have to be? According to Jacob Sherkow, the full-scope doctrine requires a patent to “enable every potential embodiment of the invention—every way or mechanism it can be achieved—arising from the way the claim is drafted.” *Patent Law’s Reproducibility Paradox*, 66 DUKE L.J. 845, 875 (2017). But “[t]here is an enablement subdoctrine—the inoperative embodiments doctrine—which renders a broad claim not necessarily invalid as long as some (perhaps most) of the subject matter works as described.” Sean B. Seymore, *Patenting Around Failure*, 166 U. PA. L. REV. 1139, 1166 (2018) (citing *In re Cook*, 439 F.2d 730, 735 (C.C.P.A. 1971); *In re Sarett*, 327 F.2d 1005, 1019 (C.C.P.A. 1964)). What are the costs and benefits of these two approaches? If there is a conflict between these doctrines, how should it be reconciled?

3. In a post about *McRO*, Dennis Crouch notes that, because enablement is a question of law, not of fact, “the defendant has the burden of *persuading the judge* on enablement, not proving its case. Lack of enablement can be supported by various factual conclusions, and those must be proven with clear and convincing evidence.” *McRO Returns to Federal Circuit: Valid but Not Infringed*, PATENTLYO (May 20, 2020), <https://patentlyo.com/patent/2020/05/returns-federal-infringed.html>. We’ll see in the next section that written description is treated as a question of fact. Does it make sense to treat these two parts of § 112(a) differently?

4. To satisfy the enablement requirement, “it is common to provide examples of how the invention is made or used. Examples often describe experiments and may provide instructions on how to make an invention or the effects of using said invention. While examples are not required, they are frequently included in patents and the absence thereof is frowned upon by the courts.” See Janet Freilich, *Prophetic Patents*, 53 U.C. DAVIS L. REV. 663, 672 (2019). Would it surprise you to know that these examples can be fictional? As Janet Freilich has explained, the USPTO and the courts “explicitly permit made-up experiments and fictional data in patents,” or “prophetic examples.” See *id.* at 666. Why would applicants want to include fictional examples in their patents? Why would the system allow them to do so? Should we be concerned that Freilich “found that 99% of citations to prophetic examples incorrectly cited the example as if it represented work that had actually been done”? *Id.* at 670.

5. One major issue in enablement is what constitutes “undue experimentation.” According to case law, “[t]he key word is ‘undue,’ not ‘experimentation.’” *In re Angstadt*, 537 F.2d 498, 504 (C.C.P.A. 1976). But how much experimentation is “undue”? There is no bright-line rule; instead, courts can consider a variety of factors, including those set forth in *In re Wands*:

Factors to be considered in determining whether a disclosure would require undue experimentation . . . (1) the quantity of experimentation necessary, (2) the amount of direction or guidance presented, (3) the presence or absence of working examples, (4) the nature of the invention, (5) the state of the prior art, (6) the relative skill of those in the art, (7) the predictability or unpredictability of the art, and (8) the breadth of the claims.

858 F.2d 731, 737 (Fed. Cir. 1988). Which way do each of these factors cut? Are there other factors that might be helpful to consider? For more details on the *Wands* factors and how courts have applied them, see JANICE M. MUELLER, *PATENT LAW* 169–82 (6th ed. 2020).

*Amgen, Inc. v. Chugai Pharm. Co.*  
927 F.2d 1200 (Fed. Cir. 1991)

LOURIE, Circuit Judge.

This appeal and cross appeal . . . involve issues of patent validity, infringement, and inequitable conduct with respect to two patents: U.S. Patent 4,703,008 ('008), owned by Kirin–Amgen Inc. (Amgen), and U.S. Patent 4,677,195 ('195), owned by Genetics Institute, Inc. (GI).

...

We affirm the district court’s holdings in all respects, except that we reverse the court’s ruling that claims 1 and 3 of the '195 patent are enabled. We also vacate that part of the district court’s judgment relating to infringement of those claims.

*Background*

Erythropoietin (EPO) is a protein consisting of 165 amino acids which stimulates the production of red blood cells. It is therefore a useful therapeutic agent in the treatment of anemias or blood disorders characterized by low or defective bone marrow production of red blood cells.

The preparation of EPO products generally has been accomplished through the concentration and purification of urine from both healthy individuals and those exhibiting high EPO levels. A new technique for producing EPO is recombinant DNA technology in which EPO is produced from cell cultures into which genetically-

## DISCLOSURE

engineered vectors containing the EPO gene have been introduced. The production of EPO by recombinant technology involves expressing an EPO gene through the same processes that occur in a natural cell.

### *The Patents*

[T]he United States Patent and Trademark Office (PTO) issued to Dr. Rodney Hewick U.S. Patent 4,677,195, entitled “Method for the Purification of Erythropoietin and Erythropoietin Compositions” (the ‘195 patent). The patent claims both homogeneous EPO and compositions thereof and a method for purifying human EPO using reverse phase high performance liquid chromatography. . . . The relevant claims of the ‘195 patent are:

1. Homogeneous erythropoietin characterized by a molecular weight of about 34,000 daltons on SDS PAGE, movement as a single peak on reverse phase high performance liquid chromatography and a specific activity of at least 160,000 IU per absorbance unit at 280 nanometers.
3. A pharmaceutical composition for the treatment of anemia comprising a therapeutically effective amount of the homogeneous erythropoietin of claim 1 in a pharmaceutically acceptable vehicle.

...

Dr. Hewick assigned the patent to GI.

The other patent in this litigation is U.S. Patent 4,703,008, entitled “DNA Sequences Encoding Erythropoietin” (the ‘008 patent), issued . . . to Dr. Fu-Kuen Lin, an employee of Amgen. The claims of the ‘008 patent cover purified and isolated DNA sequences encoding erythropoietin and host cells transformed or transfected with a DNA sequence. [The key claim in the ‘008 patent, claim 7, recited: “A purified and isolated DNA sequence consisting essentially of a DNA sequence encoding a polypeptide having an amino acid sequence sufficiently duplicative of that of erythropoietin to allow possession of the biological property of causing bone marrow cells to increase production of reticulocytes and red blood cells, and to increase hemoglobin synthesis or iron uptake.”]

### *Discussion*

#### I

Amgen argues that the district court’s holding that GI “provided clear and convincing evidence that the patent specification is insufficient to enable one of ordinary skill in the art to make and use the invention claimed in claim 7 of the ‘008 patent without undue experimentation” constituted legal error. Amgen specifically argues that the district court erred because it “did not properly address the factors which this court has held must be

considered in determining lack of enablement based on assertion of undue experimentation,” citing this court's decision in *In re Wands*.

Claim 7 is a generic claim, covering all possible DNA sequences that will encode any polypeptide having an amino acid sequence “sufficiently duplicative” of EPO to possess the property of increasing production of red blood cells. . . .

Whether a claimed invention is enabled under 35 U.S.C. § 112 is a question of law, which we review *de novo*. “To be enabling under § 112, a patent must contain a description that enables one skilled in the art to make and use the claimed invention.”

That some experimentation is necessary does not constitute a lack of enablement; the amount of experimentation, however, must not be unduly extensive. The essential question here is whether the scope of enablement of claim 7 is as broad as the scope of the claim. *See generally In re Fisher*, 427 F.2d 833 (CCPA 1970); 2 D. CHISUM, PATENTS § 7.03[7][b] (1990).

The specification of the '008 patent provides that:

one may readily design and manufacture genes coding for microbial expression of polypeptides having primary conformations which differ from that herein specified for mature EPO in terms of the identity or location of one or more residues (e.g., substitutions, terminal and intermediate additions and deletions).

DNA sequences provided by the present invention are thus seen to comprehend all DNA sequences suitable for use in securing expression in a procaryotic or eucaryotic host cell of a polypeptide product having at least a part of the primary structural conformation and one or more of the biological properties of erythropoietin, and selected from among: (a) the DNA sequences set out in FIGS. 5 and 6; (b) DNA sequences which hybridize to the DNA sequences defined in (a) or fragments thereof; and (c) DNA sequences which, but for the degeneracy of the genetic code, would hybridize to the DNA sequences defined in (a) and (b).

The district court found that over 3,600 different EPO analogs can be made by substituting at only a single amino acid position, and over a million different analogs can be made by substituting three amino acids. The patent indicates that it embraces means for preparation of “numerous” polypeptide analogs of EPO. Thus, the number of claimed DNA encoding sequences that can produce an EPO-like product is potentially enormous.

In a deposition, Dr. Elliott, who was head of Amgen’s EPO analog program, testified that he did not know whether the fifty to eighty EPO analogs Amgen had made “had the biological property of causing bone marrow cells to increase production of reticulocytes and red blood cells, and to increase hemoglobin synthesis or iron uptake.” Based on this evidence, the trial court concluded that “defendants had provided clear and convincing



## DISCLOSURE

evidence that the patent specification is insufficient to enable one of ordinary skill in the art to make and use the invention claimed in claim 7 of the '008 patent without undue experimentation." In making this determination, the court relied in particular on the lack of predictability in the art, as demonstrated by the testimony of both Dr. Goldwasser, another scientist who worked on procedures for purifying urinary EPO (uEPO), and Dr. Elliott. After five years of experimentation, the court noted, "Amgen is still unable to specify which analogs have the biological properties set forth in claim 7."

We believe the trial court arrived at the correct decision, although for the wrong reason. By focusing on the biological properties of the EPO analogs, it failed to consider the enablement of the DNA sequence analogs, which are the subject of claim 7. Moreover, it is not necessary that a patent applicant test all the embodiments of his invention; what is necessary is that he provide a disclosure sufficient to enable one skilled in the art to carry out the invention commensurate with the scope of his claims. For DNA sequences, that means disclosing how to make and use enough sequences to justify grant of the claims sought. Amgen has not done that here. In addition, it is not necessary that a court review all the *Wands* factors to find a disclosure enabling. They are illustrative, not mandatory. What is relevant depends on the facts, and the facts here are that Amgen has not enabled preparation of DNA sequences sufficient to support its all-encompassing claims.

It is well established that a patent applicant is entitled to claim his invention generically, when he describes it sufficiently to meet the requirements of Section 112. Here, however, despite extensive statements in the specification concerning all the analogs of the EPO gene that can be made, there is little enabling disclosure of particular analogs and how to make them. Details for preparing only a few EPO analog genes are disclosed. Amgen argues that this is sufficient to support its claims; we disagree. This "disclosure" might well justify a generic claim encompassing these and similar analogs, but it represents inadequate support for Amgen's desire to claim all EPO gene analogs. There may be many other genetic sequences that code for EPO-type products. Amgen has told how to make and use only a few of them and is therefore not entitled to claim all of them.

In affirming the district court's invalidation . . . , we do not intend to imply that generic claims to genetic sequences cannot be valid where they are of a scope appropriate to the invention disclosed by an applicant. That is not the case here, where Amgen has claimed every possible analog of a gene containing about 4,000 nucleotides, with a disclosure only of how to make EPO and a very few analogs.

The district court properly relied upon *Fisher* in making its decision. In that case, an applicant was attempting to claim an adrenocorticotrophic hormone preparation containing a polypeptide having at least twenty-four amino acids of a specified sequence. Only a thirty-nine amino acid product was disclosed. The court found that applicant could

not obtain claims that are insufficiently supported and hence not in compliance with the first paragraph of 35 U.S.C. § 112. It stated:

Appellant's parent application . . . discloses no products, inherently or expressly, containing other than 39 amino acids, yet the claim includes all polypeptides, of the recited potency and purity, having at least 24 amino acids in the chain in the recited sequence. The parent specification does not enable one skilled in the art to make or obtain ACTHs with other than 39 amino acids in the chain, and there has been no showing that one of ordinary skill would have known how to make or obtain such other ACTHs without undue experimentation. . . .

Section 112 requires that the scope of the claims must bear a reasonable correlation to the scope of enablement provided by the specification to persons of ordinary skill in the art.

*Fisher*, 427 F.2d at 836, 839.

Considering the structural complexity of the EPO gene, the manifold possibilities for change in its structure, with attendant uncertainty as to what utility will be possessed by these analogs, we consider that more is needed concerning identifying the various analogs that are within the scope of the claim, methods for making them, and structural requirements for producing compounds with EPO-like activity. It is not sufficient, having made the gene and a handful of analogs whose activity has not been clearly ascertained, to claim all possible genetic sequences that have EPO-like activity. Under the circumstances, we find no error in the court's conclusion that the generic DNA sequence claims are invalid under Section 112.

## II

Amgen challenges the district court's determination that "the '195 patent enables a person of ordinary skill in the art to obtain homogeneous EPO including rEPO and uEPO from natural sources" having a mean *in vivo* specific activity of at least 160,000. Claims 1 and 3 contain the limitation that EPO have a specific activity of at least 160,000 IU/AU. The district court found, based upon expert testimony from both sides, that to those skilled in the art, in the absence of an express statement in the patent, the claims would be construed to refer to *in vivo* rather than *in vitro* specific activity. To support its challenge, Amgen asserts that the district court's determination is contradicted by GI's own bioassay data and by the district court's finding that "the '195 patent fails to enable the purification of rEPO." . . .

. . .

. . . [T]he question is whether the court erred in concluding that the claims requiring 160,000 IU/AU by an *in vivo* measurement were enabled. We conclude that it did err.

## DISCLOSURE

Defendants have produced no evidence that it ever prepared EPO with a specific activity of at least 160,000 IU/AU *in vivo* using the disclosed methods. In its report to the FDA, GI stated that it had purified uEPO material “to homogeneity” by subjecting partially purified uEPO material to reverse phase high performance liquid chromatography (RP-HPLC), the technique taught by Hewick in the '195 patent. The district court found that GI reported to the FDA that the specific activity of uEPO, based on *in vivo* bioassays, was only 109,000 IU/AU.<sup>11</sup> GI originally arrived at the figure of 160,000 IU/AU by calculation, before it had the capacity to derive quantitative information from bioassays. Hewick subjected the EPO to RP-HPLC, the EPO having an actual value of 83,000 IU/AU. After weighing the chromatograph, he found that “at least fifty percent” of the area under the chromatograph curve was attributable to something other than EPO. He then doubled the 83,000, and arrived at a theoretical specific activity of “at least about 160,000 IU/AU.” That procedure, while possibly valid as a means for estimating the specific activity of a pure sample, does not establish that GI had a workable method for actually obtaining the pure material that it claimed.

Moreover, the work of others shows that Hewick did not enable the preparation of uEPO having an *in vivo* specific activity of at least 160,000, as the claims required. Dr. Kawakita, a scientist at Kumamoto University in Japan, reported an *in vivo* specific activity of 101,000 IU/AU when using RP-HPLC according to Hewick’s method. This is similar to the 109,000 value reported to the FDA by GI. Kawakita did report a value of 188,000, but did not follow the teachings in the '195 patent. Defendants also rely on the testimony of Fritsch that “I’ve also seen further data in Chugai’s PLA indicating additional urinary EPO preparation that had activities of 190,000, I believe, units per absorbance unit.” However, the document to which Fritsch referred was not offered into evidence by GI after Amgen objected to its introduction and is not before us.

...

In addition to the question of enablement regarding uEPO, the district court found that the only purification attempt on rEPO in the manner set out in the '195 patent failed to provide homogeneous EPO. The patent itself, in Example 2, discloses GI’s purification efforts on rEPO and indicates that GI did not obtain purified rEPO. As the district court found, “the patent does not contain any procedures for purifying rEPO to the point that RP-HPLC will be successful.” Thus, the patent fails to enable purification of either rEPO or uEPO.

The burden of showing non-enablement is Amgen’s, not GI’s, but in the case of a challenged patent, when substantial discovery has occurred, and there is no credible evidence that the claimed purified material can be made by those skilled in the art by the disclosed process, and all evidence from both the inventor and his assignee and from third parties is to the contrary, we conclude that Amgen has met its burden to show that the

claims have not been adequately enabled. We do not hold that one must always prove that a disclosed process operates effectively to produce a claimed product. But, under these circumstances, we conclude that the court erred in holding that claims 1 and 3 were properly enabled.

## Context & Application

1. In this case, the court discusses what are known as “genus claims.” A genus claim is “a broad patent claim that covers a group of structurally related products that incorporate the basic advance of the patented invention.” Dmitry Karshedt, Mark A. Lemley & Sean B. Seymore, *The Death of the Genus Claim*, 35 HARV. J.L. & TECH. (forthcoming 2021). Recently, a group of scholars argued that, today, genus claims in the chemical arts (*e.g.*, those filed by pharmaceutical, biotechnology, and chemical companies) “are almost invariably held invalid under 35 U.S.C. § 112(a) for failure to enable or describe the full scope of the claimed invention.” *Id.* The authors argue that this is a problem but also state that despite “the death of genus claims,” *id.* at 4, “the industry proceeds apace—investing in innovation, obtaining and enforcing patents—despite this surprising turn in the case law,” *id.* at 5. If these broad claims are now pretty much always invalid but that hasn’t changed behaviors in the marketplace, what does that tell us about patent law in the chemical arts? Patent law more generally?

## B. Written Description

Section 112(a) says that the specification must “contain a written description of the invention.” Whether this should be a separate requirement from enablement—and if so, when it applies—has been an issue of some debate. This section will examine the development of that doctrine and why it matters. But before we dive in, let’s talk a bit about patent prosecution. Patent applicants can amend and add claims during prosecution, either in the original application or in later applications.

Today, patents are often thought of not as individual documents but as part of a family of patents that is related by their connection to a common written description . . . . For example, a patent family might include an original patent application that ultimately issued as a patent (the “parent”); a continuation filed off that original patent that, also, issued as a patent at a later date (the “child”); and a continuation-in-part that issued off the second patent in the family that, too, issued as a patent at a later date (the “grandchild”).

Jason Rantanen, *The Malleability of Patent Rights*, 2015 MICH. ST. L. REV. 895, 947 (2015). The Patent Act provides:

## DISCLOSURE

An application for patent for an invention disclosed in the manner provided by section 112(a) (other than the requirement to disclose the best mode) in an application previously filed in the United States, . . . which names an inventor or joint inventor in the previously filed application *shall have the same effect, as to such invention, as though filed on the date of the prior application, if filed before the patenting or abandonment of or termination of proceedings on the first application or on an application similarly entitled to the benefit of the filing date of the first application and if it contains or is amended to contain a specific reference to the earlier filed application. . . .*

35 U.S.C. § 120 (emphasis added). These applications are called “continuations.” As Stephanie Plamondon Bair has explained:

The main categories of continuation applications include *continuations*, *requests for continued examination* (RCEs, which are technically a subset of continuations), *continuations-in-part* (CIPs), and *divisionals*. Applicants file traditional continuation applications when they wish to argue for broader claims after some claims have been allowed. When no claims have been allowed and a final rejection has been issued, a continuation is labeled as an RCE. In contrast to traditional continuations and RCEs, a CIP application allows the applicant to add new information [i.e., “new matter”] to the continuation application. For CIPs, the priority date of the parent application is only available for those claims that do not make use of this additional information. Finally, a divisional application is usually filed following a finding by the USPTO that a single patent application contains two or more distinct inventions. The patentee may then file multiple related divisional applications, one for each distinct invention.

*Adjustments, Extensions, Disclaimers, and Continuations: When Do Patent Term Adjustments Make Sense?*, 41 CAP. U. L. REV. 445, 465 (2013) (emphasis added).

[A] continuation allows an applicant to pursue claims broader than those that were allowed for possible later issue. A continuation application provides an attractive alternative to filing a new application for these broader claims because the continuation application effectively continues the initial application, allowing an applicant to claim the initial filing date for these claims, and thereby avoiding the possibility that intervening innovations (or the parent application itself) will act as prior art that renders the later, broader claims unpatentable.

*Id.* at 464. And “[t]here is no limit to the number of continuation applications that may be filed.” *Id.* But why wait? As you read the following cases, think about why an applicant might want to save its broader claims (or any claims) for a continuation application, as opposed to putting them all in the original application. Why might we, as a system, not

want to let patent applicants make any changes that they want, any time they want to? As you read the next case, pay close attention to how and when the disputed claim was added to the patent.

*In re Ruschig*  
379 F.2d 990 (C.C.P.A. 1967)

RICH, Judge.

This appeal is from the decision of the Patent Office Board of Appeals affirming the rejection of claim 13 of application serial No. 601,107, filed July 31, 1956, for "New Benzene Sulfonyl Ureas and Process for Their Preparation" Apparently The Upjohn Company has been prosecuting the application.

. . . The claim on appeal . . . reads: "13. N-(p-chlorobenzenesulfonyl) -N-propylurea." . . . It is known by the generic name chlorpropamide and is sold under the trademark Diabinese by Chas. Pfizer & Co., Inc., as an oral medication for the control of diabetes mellitus . . . .

The sole issue on this appeal is whether claim 13 is supported by the disclosure of appellants' application . . . .

[Upjohn added Claim 13 to the application "about a year after it was filed" and there was a dispute about whether Upjohn or Pfizer, who had filed a separate application, was entitled to the patent for chlorpropamide.]

. . .

It does not seem to be contested that the general disclosure of the application encompasses something like half a million possible compounds. It also discloses a number of specific compounds. Appellants' argument is that one skilled in the art would find certain "guides" in the specification which would lead him to the compound of claim 13 and that the compound is therefore disclosed. . . .

. . .

Appellants say . . . that the "guide" becomes more crystallized by the recitation of the alkylamines which can be employed in the four or five reactions described as using them. This list contains at least 19 primary amines which the specification says may be used. Appellants emphasize two, n-butylamine, which is elsewhere specifically disclosed as having been used, and n-propylamine. We do not see that listing the latter with the 18 others adds anything to the initial statement that one may use an alkyl amine containing from 2 to 6 carbon atoms. Propylamine is such an amine but one is not led to it in

## DISCLOSURE

preference to the others merely by listing them all and identifying it, with the others, by name.

Finally appellants refer to two tables listing, respectively, ten and twelve specific compounds, the first being the list of specific compounds whose blood sugar lowering activity is shown in the specification, the other, which duplicates the first and adds two compounds, being the specific examples of the specification. There is no N'-n-propyl compound among them. Perhaps one of appellants' best points is that the activity table "stresses" compounds in which R(2) is a primary alkyl radical, i.e., ethyl, butyl, isobutyl and hexyl. The stress resides in the fact that eight of the ten are such compounds. And one of them, N-(4-chlorobenzenesulphonyl)-N'n-butyl urea, is a homolog of the compound of claim 13. It must be admitted that this is getting close. If n-propylamine had been used in making the compound instead of n-butylamine, the compound of claim 13 would have resulted. Appellants submit to us, as they did to the board, an imaginary specific example patterned on specific example 6 by which the above butyl compound is made so that we can see what a simple change would have resulted in a specific supporting disclosure being present in the specification. The trouble is that there is no such disclosure, easy though it is to imagine it. It is equally easy to imagine that the compound of claim 13 might have been named in the specification. Working backward from a knowledge of chlorpropamide, that is by hindsight, it is all very clear what route one would travel through the forest of the specification to arrive at it. But looking at the problem, as we must, from the standpoint of one with no foreknowledge of the specific compound, it is our considered opinion that the board was correct in saying:

Not having been specifically named or mentioned in any manner, one is left to selection from the myriads of possibilities encompassed by the broad disclosure, with no guide indicating or directing that this particular selection should be made rather than any of the many others which could also be made.

Appellants refer to 35 U.S.C. § 112 as the presumed basis for this rejection and emphasize language therein about enabling one skilled in the art to make the invention, arguing therefrom that one skilled in the art would be enabled by the specification to make chlorpropamide. We find the argument unpersuasive for two reasons. First, it presumes some motivation for wanting to make the compound in preference to others. While we have no doubt a person so motivated would be enabled by the specification to make it, this is beside the point for the question is not whether he would be so enabled but whether the specification discloses the compound to him, specifically, as something appellants actually invented. We think it does not. Second, we doubt that the rejection is truly based on section 112, at least on the parts relied on by appellants. If based on section 112, it is on the requirement thereof that "The specification shall contain a written description of the invention." We have a specification which describes appellants' invention. The issue here

is in no wise a question of its compliance with section 112, it is a question of *fact*: *Is the compound of claim 13 described therein?* Does the specification convey clearly to those skilled in the art, to whom it is addressed, in any way, the information that appellants invented that specific compound? Having considered the specification in the light that has been shed on it by all the arguments pro and con, we conclude that it does not.

The decision of the board is affirmed.

*Vas-Cath Inc. v. Mahurkar*  
935 F.2d 1555 (Fed. Cir. 1991)

RICH, Circuit Judge.

Sakharam D. Mahurkar and Quinton Instruments Company (collectively Mahurkar) appeal . . . Granting partial summary judgment to Vas-Cath Incorporated and its licensee Gambro, Inc. (collectively Vas-Cath), the district court declared Mahurkar's two United States utility patents Nos. 4,568,329 ('329 patent) and 4,692,141 ('141 patent), titled "Double Lumen Catheter," invalid as anticipated under 35 U.S.C. § 102(b). In reaching its decision . . . , the district court concluded that none of the twenty-one claims of the two utility patents was entitled, under 35 U.S.C. § 120, to the benefit of the filing date of Mahurkar's earlier-filed United States design patent application Serial No. 356,081 ('081 design application), which comprised the same drawings as the utility patents, because the design application did not provide a "written description of the invention" as required by 35 U.S.C. § 112, first paragraph. We reverse the grant of summary judgment with respect to all claims.

#### *Background*

Sakharam Mahurkar filed the '081 design application, also titled "Double Lumen Catheter," on March 8, 1982. The application was abandoned on November 30, 1984. Figures 1–6 of the '081 design application are reproduced below.



DISCLOSURE

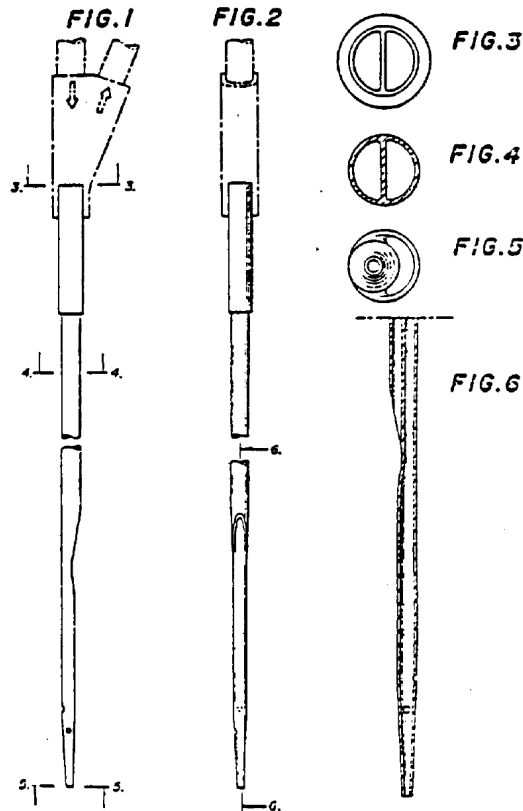

As shown, Mahurkar's catheter comprises a pair of tubes (lumens) designed to allow blood to be removed from an artery, processed in an apparatus that removes impurities, and returned close to the place of removal. Prior art catheters utilized concentric circular lumens, while Mahurkar's employs joined semi-circular tubes that come to a single tapered tip. Advantageously, the puncture area of Mahurkar's semicircular catheter is 42% less than that of a coaxial catheter carrying the same quantity of blood, and its conical tip yields low rates of injury to the blood. The prior art coaxial catheters are now obsolete; Mahurkar's catheters appear to represent more than half of the world's sales.

After filing the '081 design application, Mahurkar also filed a Canadian Industrial Design application comprising the same drawings plus additional textual description. On August 9, 1982, Canadian Industrial Design 50,089 (Canadian '089) issued on that application.

More than one year later, on October 1, 1984, Mahurkar filed the first of two utility patent applications that would give rise to the patents now on appeal. Notably, both utility applications included the same drawings as the '081 design application. Serial No. 656,601 ('601 utility application) claimed the benefit of the filing date of the '081 design

application, having been denominated a “continuation” thereof. In an Office Action mailed June 6, 1985, the Patent and Trademark Office (PTO) examiner noted that “the prior application is a design application,” but did not dispute that the ’601 application was entitled to its filing date. On January 29, 1986, Mahurkar filed Serial No. 823,592 (’592 utility application), again claiming the benefit of the filing date of the ’081 design application (the ’592 utility application was denominated a continuation of the ’601 utility application). In an office action mailed April 1, 1987, the examiner stated that the ’592 utility application was “considered to be fully supported by applicant’s parent application [the ’081 design application].” The ’601 and ’592 utility applications issued in 1986 and 1987, respectively, as the ’329 and ’141 patents, the subjects of this appeal. . . .

Vas–Cath sued Mahurkar in June 1988, seeking a declaratory judgment that the catheters it manufactured did not infringe Mahurkar’s ’329 and ’141 utility patents. Vas–Cath’s complaint alleged, *inter alia*, that the ’329 and ’141 patents were both invalid as anticipated under 35 U.S.C. § 102(b) by Canadian ’089. Vas–Cath’s anticipation theory was premised on the argument that the ’329 and ’141 patents were not entitled under 35 U.S.C. § 1204 to the filing date of the ’081 design application because its drawings did not provide an adequate “written description” of the claimed invention as required by 35 U.S.C. § 112, first paragraph.

Mahurkar counterclaimed, alleging infringement. Both parties moved for summary judgment on certain issues, including validity. For purposes of the summary judgment motion, Mahurkar conceded that, if he could not antedate it, Canadian ’089 would represent an enabling and thus anticipating § 102(b) reference against the claims of his ’329 and ’141 utility patents. Vas–Cath conceded that the ’081 design drawings enabled one skilled in the art to practice the claimed invention within the meaning of 35 U.S.C. § 112, first paragraph. Thus, the question before the district court was whether the disclosure of the ’081 design application, namely, the drawings without more, adequately meets the “written description” requirement also contained in § 112, first paragraph, so as to entitle Mahurkar to the benefit of the 1982 filing date of the ’081 design application for his two utility patents and thereby antedates Canadian ’089.

Concluding that the drawings do not do so, and that therefore the utility patents are anticipated by Canadian ’089, the district court held the ’329 and ’141 patents wholly invalid under 35 U.S.C. § 102(b), and subsequently granted Mahurkar’s motion for entry of a partial final judgment under Fed. R. Civ. P. 54(b) on the validity issue. This appeal followed.

#### *Discussion*

The issue before us is whether the district court erred in concluding, on summary judgment, that the disclosure of the ’081 design application does not provide a §112, first

## DISCLOSURE

paragraph “written description” adequate to support each of the claims of the ’329 and ’141 patents. If the court so erred as to any of the 21 claims at issue, the admittedly anticipatory disclosure of Canadian ’089 will have been antedated (and the basis for the court’s grant of summary judgment nullified) as to those claims.

### *The “Written Description” Requirement of § 112*

The first paragraph of 35 U.S.C. § 112 requires that

the specification shall contain *a written description of the invention*, and of the manner and process of making and using it, in such full, clear, concise, and exact terms as to enable any person skilled in the art to which it pertains, or with which it is most nearly connected, to make and use the same, and shall set forth the best mode contemplated by the inventor of carrying out his invention.

Application of the “written description” requirement, derived from the portion of § 112 emphasized above, is central to resolution of this appeal. The district court, having reviewed this court’s decisions on the subject, remarked that “unfortunately, it is not so easy to tell what the law of the Federal Circuit is.” Perhaps that is so, and, therefore, before proceeding to the merits, we review the case law development of the “written description” requirement with a view to improving the situation.

The cases indicate that the “written description” requirement most often comes into play where claims not presented in the application when filed are presented thereafter. Alternatively, patent applicants often seek the benefit of the filing date of an earlier-filed foreign or United States application under 35 U.S.C. § 119 or 35 U.S.C. § 120, respectively, for claims of a later-filed application. The question raised by these situations is most often phrased as whether the application provides “adequate support” for the claim(s) at issue; it has also been analyzed in terms of “new matter” under 35 U.S.C. § 132. The “written description” question similarly arises in the interference context, where the issue is whether the specification of one party to the interference can support the claim(s) corresponding to the count(s) at issue, i.e., whether that party “can make the claim” corresponding to the interference count.

To the uninitiated, it may seem anomalous that the first paragraph of 35 U.S.C. § 112 has been interpreted as requiring a separate “description of the invention,” when the invention is, necessarily, the subject matter defined in the claims under consideration. One may wonder what purpose a separate “written description” requirement serves, when the second paragraph of § 112 expressly requires that the applicant conclude his specification “with one or more claims particularly pointing out and distinctly claiming the subject matter which the applicant regards as his invention.”

One explanation is historical: the “written description” requirement was a part of the patent statutes at a time before claims were required. A case in point is *Evans v. Eaton*, 20 U.S. (7 Wheat.) 356 (1822), in which the Supreme Court affirmed the circuit court’s decision that the plaintiff’s patent was “deficient,” and that the plaintiff could not recover for infringement thereunder. The patent laws then in effect, namely the Patent Act of 1793, did not require claims, but did require, in its 3d section, that the patent applicant “deliver a written description of his invention, and of the manner of using, or process of compounding, the same, in such full, clear and exact terms, as to distinguish the same from all things before known, and to enable any person skilled in the art or science of which it is a branch, or with which it is most nearly connected, to make, compound and use the same.” In view of this language, the Court concluded that the specification of a patent had two objects, the first of which was “to enable artizans to make and use the invention.” The second object of the specification was

to put the public in possession of what the party claims as his own invention, so as to ascertain if he claims anything that is in common use, or is already known, and to guard against prejudice or injury from the use of an invention which the party may otherwise innocently suppose not to be patented. It is, therefore, for the purpose of warning an innocent purchaser, or other person using a machine, of his infringement of the patent; and at the same time, of taking from the inventor the means of practising upon the credulity or the fears of other persons, by pretending that his invention is more than what it really is, or different from its ostensible objects, that the patentee is required to distinguish his invention in his specification.

A second, policy-based rationale for the inclusion in § 112 of both the first paragraph “written description” and the second paragraph “definiteness” requirements was set forth in *Rengo Co. v. Molins Mach. Co.*, 657 F.2d 535, 551 (3d Cir. 1981):

There is a subtle relationship between the policies underlying the description and definiteness requirements, as the two standards, while complementary, approach a similar problem from different directions. Adequate description of the invention guards against the inventor's overreaching by insisting that he recount his invention in such detail that his future claims can be determined to be encompassed within his original creation. The definiteness requirement shapes the future conduct of persons other than the inventor, by insisting that they receive notice of the scope of the patented device.

With respect to the first paragraph of § 112 the severability of its “written description” provision from its enablement (“make and use”) provision was recognized by this court’s predecessor, the Court of Customs and Patent Appeals, as early as *In re Ruschig*, 379 F.2d 990 (CCPA 1967). . . . The issue, as the court saw it, was one of fact: “Does the specification

## DISCLOSURE

convey clearly to those skilled in the art, to whom it is addressed, in any way, the information that appellants invented that specific compound claimed?”

In a 1971 case again involving chemical subject matter, the court expressly stated that “it is possible for a specification to *enable* the practice of an invention as broadly as it is claimed, and still not *describe* that invention.” *In re DiLeone*, 436 F.2d 1404, 1405 (CCPA 1971). As an example, the court posited the situation “where the specification discusses only compound A and contains no broadening language of any kind. This might very well enable one skilled in the art to make and use compounds B and C; yet the class consisting of A, B and C has not been described.”

The CCPA also recognized a subtle distinction between a written description adequate to support a claim under § 112 and a written description sufficient to anticipate its subject matter under § 102(b). The difference between “claim-supporting disclosures” and “claim-anticipating disclosures” was dispositive in *In re Lukach*, 442 F.2d 967 (CCPA 1971), where the court held that a U.S. “grandparent” application did not sufficiently describe the later-claimed invention, but that the appellant’s intervening British application, a counterpart to the U.S. application, anticipated the claimed subject matter. As the court pointed out, “the description of a single embodiment of broadly claimed subject matter constitutes a description of the invention for anticipation purposes, whereas the same information in a specification might not alone be enough to provide a description of that invention for purposes of adequate disclosure.”

The purpose and applicability of the “written description” requirement were addressed in *In re Smith and Hubin*, 481 F.2d 910 (CCPA 1973), where the court stated:

Satisfaction of the description requirement insures that subject matter presented in the form of a claim subsequent to the filing date of the application was sufficiently disclosed at the time of filing so that the prima facie date of invention can fairly be held to be the filing date of the application. This concept applies whether the case factually arises out of an assertion of entitlement to the filing date of a previously filed application under § 120 or arises in the interference context wherein the issue is support for a count in the specification of one or more of the parties or arises in an ex parte case involving a single application, but where the claim at issue was filed subsequent to the filing of the application.

The CCPA’s “written description” cases often stressed the fact-specificity of the issue. The court even went so far as to state:

It should be readily apparent from recent decisions of this court involving the question of compliance with the description requirement of § 112 that each case must be decided on its own facts. Thus, the precedential value of cases in this area is extremely limited.

*In re Driscoll*, 562 F.2d 1245, 1250 (CCPA 1977).

Since its inception, the Court of Appeals for the Federal Circuit has frequently addressed the “written description” requirement of § 112. A fairly uniform standard for determining compliance with the “written description” requirement has been maintained throughout: “Although the applicant does not have to describe exactly the subject matter claimed, the description must clearly allow persons of ordinary skill in the art to recognize that he or she invented what is claimed.” “The test for sufficiency of support in a parent application is whether the disclosure of the application relied upon reasonably conveys to the artisan that the inventor had possession at that time of the later claimed subject matter.” Our cases also provide that compliance with the “written description” requirement of § 112 is a question of fact, to be reviewed under the clearly erroneous standard.

There appears to be some confusion in our decisions concerning the extent to which the “written description” requirement is separate and distinct from the enablement requirement. For example, in *In re Wilder*, 736 F.2d 1516, 1520 (Fed. Cir. 1984), we flatly stated: “The description requirement is found in 35 U.S.C. § 112 and is separate from the enablement requirement of that provision.” However, in a later case we said, “The purpose of the written description requirement of section 112, first paragraph is to state what is needed to fulfill the enablement criteria. These requirements may be viewed separately, but they are intertwined.” *Kennecott Corp. v. Kyocera Int’l, Inc.*, 835 F.2d 1419, 1421 (Fed. Cir. 1987). “The written description must communicate that which is needed to enable the skilled artisan to make and use the claimed invention.”

To the extent that *Kennecott* conflicts with *Wilder*, we note that decisions of a three-judge panel of this court cannot overturn prior precedential decisions. This court in *Wilder* (and the CCPA before it) clearly recognized, and we hereby reaffirm, that 35 U.S.C. § 112, first paragraph, requires a “written description of the invention” which is separate and distinct from the enablement requirement. The purpose of the “written description” requirement is broader than to merely explain how to “make and use”; the applicant must also convey with reasonable clarity to those skilled in the art that, as of the filing date sought, he or she was in possession of the invention. The invention is, for purposes of the “written description” inquiry, whatever is now claimed.

#### *The District Court’s Analysis*

We agree with the district court’s conclusion that drawings alone may be sufficient to provide the “written description of the invention” required by § 112, first paragraph. Several earlier cases, though not specifically framing the issue in terms of compliance with the “written description” requirement, support this conclusion.

## DISCLOSURE

For example, we previously stated that “there is no statutory prohibition against an applicant’s reliance, in claiming priority under 35 U.S.C. § 120, on a disclosure in a design application if the statutory conditions are met.”

...

These cases support our holding that, under proper circumstances, drawings alone may provide a “written description” of an invention as required by § 112. Whether the drawings are those of a design application or a utility application is not determinative, although in most cases the latter are much more detailed. In the instant case, however, the design drawings are substantially identical to the utility application drawings.

Although we join with the district court in concluding that drawings may suffice to satisfy the “written description” requirement of § 112, we can not agree with the legal standard that the court imposed for “written description” compliance, nor with the court’s conclusion that no genuine issues of material fact were in dispute.

With respect to the former, the district court stated that although the ’081 design drawings in question “allowed practice” i.e., enabled, they did not necessarily “show what the invention is . . . .” We find the district court’s concern with “what the invention is” misplaced, and its requirement that the ’081 drawings “describe what is novel or important” legal error. There is “no legally recognizable or protected ‘essential’ element, ‘gist’ or ‘heart’ of the invention in a combination patent.” “The invention” is defined by the claims on appeal. The instant claims do not recite only a pair of semi-circular lumens, or a conical tip, or a ratio at which the tip tapers, or the shape, size, and placement of the inlets and outlets; they claim a double lumen catheter having a combination of those features. That combination invention is what the ’081 drawings show. As the district court itself recognized, “what Mahurkar eventually patented is exactly what the pictures in serial ’081 show.”

...

The district court erred in taking Mahurkar’s other patents into account. Mahurkar’s later patenting of inventions involving different range limitations is irrelevant to the issue at hand. Application sufficiency under § 112, first paragraph, must be judged as of the filing date.

### *Conclusion*

The district court’s grant of summary judgment, holding all claims of the ’329 and ’141 patents invalid under 35 U.S.C. § 102(b), is hereby reversed as to all claims, and the case remanded for further proceedings consistent herewith.

## Context & Application

1. Why don't we let patent applicants amend or add claims at will? The Federal Circuit has said that:

[T]here is nothing improper, illegal or inequitable in filing a patent application for the purpose of obtaining a right to exclude a known competitor's product from the market; nor is it in any manner improper to amend or insert claims intended to cover a competitor's product the applicant's attorney has learned about during the prosecution of a patent application.

*Kingsdown Med. Consultants, Ltd. v. Hollister Inc.*, 863 F.2d 867, 874 (Fed. Cir. 1988). Where is the line between allowable amendments and prohibited ones? Where *should* that line be? Now that you know a little about patent continuation practice, do you see any opportunities for shenanigans? How does the written description requirement help (or not help) address those issues?

2. We've seen that utility patent applications can claim priority to design patent applications. The reverse is also true; design patent applications can claim priority to non-provisional utility patent applications. MPEP §§ 1504.10, 1504.20. This means that someone could try to get a utility patent, have it rejected, then file a continuation application seeking a design patent for a design disclosed in original application's drawings. This also has implications for patent terms. Utility patent terms are calculated based on the filing date, *see* 35 U.S.C. § 154(a)(2), while design patent terms are based on the issuance date, *see* 35 U.S.C. § 173.

3. As the court alluded to in *Vas-Cath*, a piece of prior art must be enabling to invalidate. (For more on invalidating claims, *see* Chapter 6.) What would happen if someone made a working transporter, like the fictional one shown on "Star Trek"? Could the television show anticipate a patent claim that covered the working transporter? How would you start to analyze that issue, based just on what you know now?

4. In *Vas-Cath*, the court mentions the concept of "new matter." The Patent Act states: "No amendment shall introduce new matter into the disclosure of the invention." 35 U.S.C. § 132(a). Why should new matter be prohibited? What consequences flow if new matter is added?

5. In *Vas-Cath*, the court also talks about interferences. "An interference is a contest under pre-AIA 35 U.S.C. 135(a) between an application and either another application or a patent. An interference is declared to assist the [USPTO] . . . in determining priority, that is, which party first invented the commonly claimed invention . . ." MPEP § 2301. As we'll see in Chapter 6, the AIA changed the rules for patent priority; one consequence of that change is that there are no interferences for patents governed by the AIA.



DISCLOSURE

*Ariad Pharmaceuticals, Inc. v. Eli Lilly & Co.*  
598 F.3d 1336 (Fed. Cir. 2010) (*en banc*)

LOURIE, Circuit Judge.

Ariad Pharmaceuticals, Inc., Massachusetts Institute of Technology, the Whitehead Institute for Biomedical Research, and the President and Fellows of Harvard College (collectively, “Ariad”) brought suit against Eli Lilly & Company (“Lilly”) in the United States District Court for the District of Massachusetts, alleging infringement of U.S. Patent 6,410,516 (“the ‘516 patent”). . . . [A] panel of this court reversed the district court’s denial of Lilly’s motion for judgment as a matter of law (“JMOL”) and held the asserted claims invalid for lack of written description.

. . .

In light of the controversy concerning the distinctness and proper role of the written description requirement, we granted Ariad’s petition [for rehearing *en banc*], . . . directing the parties to brief two questions:

- (1) Whether 35 U.S.C. § 112, paragraph 1, contains a written description requirement separate from an enablement requirement?
- (2) If a separate written description requirement is set forth in the statute, what is the scope and purpose of that requirement?

In addition to the parties’ briefs, the court received twenty-five amicus briefs. . . .

I

[A]lthough the parties take diametrically opposed positions on the existence of a written description requirement separate from enablement, both agree that the specification must contain a written description of the invention to establish what the invention is. The dispute, therefore, centers on the standard to be applied and whether it applies to original claim language.

A

As in any case involving statutory interpretation, we begin with the language of the statute itself. Section 112, first paragraph, reads as follows:

The specification shall contain a written description of the invention, and of the manner and process of making and using it, in such full, clear, concise, and exact terms as to enable any person skilled in the art to which it pertains, or with which it is most nearly connected, to make and use the same, and shall set forth the best mode contemplated by the inventor of carrying out his invention.

## CHAPTER 5

According to Ariad, a plain reading of the statute reveals two components: a written description (i) of the invention, and (ii) of the manner and process of making and using it. Yet those two components, goes Ariad's argument, must be judged by the final prepositional phrase . . . . Specifically, Ariad parses the statute as follows:

The specification shall contain

[A] a written description

[i] of the invention, and

[ii] of the manner and process of making and using it,

[B] in such full, clear, concise, and exact terms as to enable any person skilled in the art to which it pertains, or with which it is most nearly connected, to make and use the same ...

Ariad argues that its interpretation best follows the rule of English grammar that prepositional phrases (here, "of the invention," "of the manner and process of making and using it," and "in such full, clear, concise, and exact terms") modify another word in the sentence (here, "written description"), and that it does not inexplicably ignore the comma after "making and using it" or sever the "description of the invention" from the requirement that it be in "full, clear, concise, and exact terms," leaving the description without a legal standard.

Ariad also argues that earlier versions of the Patent Act support its interpretation. Specifically, Ariad contends that the first Patent Act, adopted in 1790, and its immediate successor, adopted in 1793, required a written description of the invention that accomplished two purposes: (i) to distinguish the invention from the prior art, and (ii) to enable a person skilled in the art to make and use the invention. Ariad then asserts that when Congress assigned the function of defining the invention to the claims in 1836, Congress amended the written description requirement so that it served a single purpose: enablement.

Lilly disagrees, arguing that § 112, first paragraph, contains three separate requirements. Specifically, Lilly parses the statute as follows:

(1) "The specification shall contain a written description of the invention, and"

(2) "The specification shall contain a written description . . . of the manner and process of making and using it, in such full, clear, concise, and exact terms as to enable any person skilled in the art to which it pertains, or with which it is most nearly connected, to make and use the same, and "

(3) "The specification . . . shall set forth the best mode contemplated by the inventor of carrying out the invention."

## DISCLOSURE

Lilly argues that Ariad's construction ignores a long line of judicial precedent interpreting the statute's predecessors to contain a separate written description requirement, an interpretation Congress adopted by reenacting the current language of § 112, first paragraph, without significant amendment.

We agree with Lilly and read the statute to give effect to its language that the specification "shall contain a written description of the invention" and hold that § 112, first paragraph, contains two separate description requirements: a "written description [i] of the invention, *and* [ii] of the manner and process of making and using the invention." 35 U.S.C. § 112, ¶ 1. On this point, we do not read Ariad's position to be in disagreement as Ariad concedes the existence of a written description requirement. Instead Ariad contends that the written description requirement exists, not for its own sake as an independent statutory requirement, but only to identify the invention that must comply with the enablement requirement.

But, unlike Ariad, we see nothing in the statute's language or grammar that unambiguously dictates that the adequacy of the "written description of the invention" must be determined solely by whether that description identifies the invention so as to enable one of skill in the art to make and use it. The prepositional phrase "in such full, clear, concise, and exact terms as to enable any person skilled in the art . . . to make and use the same" modifies only "the written description . . . of the manner and process of making and using the invention," as Lilly argues, without violating the rules of grammar. That the adequacy of the description of the manner and process of making and using the invention is judged by whether that description enables one skilled in the art to make and use the same follows from the parallelism of the language.

While Ariad agrees there is a requirement to describe the invention, a few amici appear to suggest that the only description requirement is a requirement to describe enablement. If Congress had intended enablement to be the sole description requirement of § 112, first paragraph, the statute would have been written differently. Specifically, Congress could have written the statute to read, "The specification shall contain a written description of the invention, in such full, clear, concise, and exact terms as to enable any person skilled in the art . . . to make and use the same," or "The specification shall contain a written description of the manner and process of making and using the invention, in such full, clear, concise, and exact terms as to enable any person skilled in the art . . . to make and use the same." Under the amici's construction a portion of the statute—either "and of the manner and process of making and using it" or "a written description of the invention"—becomes surplusage, violating the rule of statutory construction that Congress does not use unnecessary words.

Furthermore, since 1793, the Patent Act has expressly stated that an applicant must provide a written description of the invention, and after the 1836 Act added the

requirement for claims, the Supreme Court applied this description requirement separate from enablement. Congress recodified this language in the 1952 Act, and nothing in the legislative history indicates that Congress intended to rid the Act of this requirement. On the contrary, “Congress is presumed to be aware of a judicial interpretation of a statute and to adopt that interpretation when it reenacts a statute without change.”

Finally, a separate requirement to describe one’s invention is basic to patent law. Every patent must describe an invention. It is part of the quid pro quo of a patent; one describes an invention, and, if the law’s other requirements are met, one obtains a patent. The specification must then, of course, describe how to make and use the invention (i.e., enable it), but that is a different task. A description of the claimed invention allows the United States Patent and Trademark Office (“PTO”) to examine applications effectively; courts to understand the invention, determine compliance with the statute, and to construe the claims; and the public to understand and improve upon the invention and to avoid the claimed boundaries of the patentee’s exclusive rights.

## B

Ariad argues . . . that in *Evans v. Eaton*, 20 U.S. (7 Wheat.) (1822), the Supreme Court recognized just two requirements under § 3 of the 1793 Act, the requirements “to enable” the invention and “to distinguish” it from all things previously known. And, goes Ariad’s argument, since the 1836 Act, which removed the latter language and added the requirement for claims, the Court has consistently held that a patent applicant need fulfill but a single “written description” requirement, the measure of which is enablement.

Lilly disagrees and reads *Evans* as acknowledging a written description requirement separate from enablement. Lilly further contends that the Court has continually confirmed the existence of a separate written description requirement, including in *O’Reilly v. Morse*, 56 U.S. (15 How.) 62 (1853) under the 1836 Act; *Schriber-Schroth Co. v. Cleveland Trust Co.*, 305 U.S. 47 (1938), under the 1870 Act; and more recently in *Festo Corp. v. Shoketsu Kinzoku Kogyo Kabushiki Co.*, 535 U.S. 722, 736 (2002).

Like Lilly, we also read Supreme Court precedent as recognizing a written description requirement separate from an enablement requirement even after the introduction of claims. Specifically, in *Schriber-Schroth*, the Court held that a patent directed to pistons for a gas engine with “extremely rigid” webs did not adequately describe amended claims that recited flexible webs under the then-in-force version of § 112, first paragraph. The Court ascribed two purposes to this portion of the statute, only the first of which involved enablement:

[1] to require the patentee to describe his invention so that others may construct and use it after the expiration of the patent and [2] to inform the public during the life of the patent of the limits of the monopoly asserted, so that it may be known

## DISCLOSURE

which features may be safely used or manufactured without a license and which may not.

The Court then concluded that even if the original specification enabled the use of a flexible web, the claim could derive no benefit from it because “that was not the invention which the patentee described by his references to an extremely rigid web.” Although the Court did not expressly state that it was applying a description of the invention requirement separate from enablement, that is exactly what the Court did.

Further, both before and after *Schriber-Schroth*, the Court has stated that the statute serves a purpose other than enablement. In *Gill v. Wells*, 89 U.S. (22 Wall.) 1 (1874), the Court held invalid a reissue patent for claiming a combination not described in the original application, but the Court also emphasized the need for all patents to meet the “three great ends” of § 26, only one of which was enablement. Specifically, the Court stated:

(1) That the government may know what they have granted and what will become public property when the term of the monopoly expires. (2) That licensed persons desiring to practice the invention may know, during the term, how to make, construct, and use the invention. (3) That other inventors may know what part of the field of invention is unoccupied.

As a subordinate federal court, we may not so easily dismiss such statements as dicta but are bound to follow them.

## C

In addition to the statutory language and Supreme Court precedent supporting the existence of a written description requirement separate from enablement, *stare decisis* impels us to uphold it now. Ariad acknowledges that this has been the law for over forty years, and to change course now would disrupt the settled expectations of the inventing community, which has relied on it in drafting and prosecuting patents, concluding licensing agreements, and rendering validity and infringement opinions. As the Supreme Court stated in admonishing this court, we “must be cautious before adopting changes that disrupt the settled expectations of the inventing community.” If the law of written description is to be changed, contrary to sound policy and the uniform holdings of this court, the settled expectations of the inventing and investing communities, and PTO practice, such a decision would require good reason and would rest with Congress.

## E

In contrast to amended claims, the parties have more divergent views on the application of a written description requirement to original claims. Ariad argues that *Regents of the University of California v. Eli Lilly & Co.*, 119 F.3d 1559 (Fed. Cir. 1997),

extended the requirement beyond its proper role of policing priority as part of enablement and transformed it into a heightened and unpredictable general disclosure requirement in place of enablement. Rather, Ariad argues, the requirement to describe what the invention is does not apply to original claims because original claims, as part of the original disclosure, constitute their own written description of the invention. Thus, according to Ariad, as long as the claim language appears *in ipsius verbis* in the specification as filed, the applicant has satisfied the requirement to provide a written description of the invention.

Lilly responds that the written description requirement applies to all claims and requires that the specification objectively demonstrate that the applicant actually invented—was in possession of—the claimed subject matter. Lilly argues that § 112 contains no basis for applying a different standard to amended versus original claims and that applying a separate written description requirement to original claims keeps inventors from claiming beyond their inventions and thus encourages innovation in new technological areas by preserving patent protection for actual inventions.

Again we agree with Lilly. If it is correct to read § 112, first paragraph, as containing a requirement to provide a separate written description of the invention, as we hold here, Ariad provides no principled basis for restricting that requirement to establishing priority. Certainly nothing in the language of § 112 supports such a restriction; the statute does not say “The specification shall contain a written description of the invention for purposes of determining priority.” And although the issue arises primarily in cases involving priority, Congress has not so limited the statute, and neither will we.

Furthermore, while it is true that original claims are part of the original specification, that truism fails to address the question whether original claim language necessarily discloses the subject matter that it claims. Ariad believes so, arguing that original claims identify whatever they state, e.g., a perpetual motion machine, leaving only the question whether the applicant has enabled anyone to make and use such an invention. We disagree that this is always the case. Although many original claims will satisfy the written description requirement, certain claims may not. For example, a generic claim may define the boundaries of a vast genus of chemical compounds, and yet the question may still remain whether the specification, including original claim language, demonstrates that the applicant has invented species sufficient to support a claim to a genus. The problem is especially acute with genus claims that use functional language to define the boundaries of a claimed genus. In such a case, the functional claim may simply claim a desired result, and may do so without describing species that achieve that result. But the specification must demonstrate that the applicant has made a generic invention that achieves the claimed result and do so by showing that the applicant has invented species sufficient to support a claim to the functionally-defined genus.

## DISCLOSURE

Recognizing this, we held in *Eli Lilly* that an adequate written description of a claimed genus requires more than a generic statement of an invention's boundaries. The patent at issue in *Eli Lilly* claimed a broad genus of cDNAs purporting to encode many different insulin molecules, and we held that its generic claim language to "vertebrate insulin cDNA" or "mammalian insulin cDNA" failed to describe the claimed genus because it did not distinguish the genus from other materials in any way except by function, i.e., by what the genes do, and thus provided "only a definition of a useful result rather than a definition of what achieves that result."

We held that a sufficient description of a genus instead requires the disclosure of either a representative number of species falling within the scope of the genus or structural features common to the members of the genus so that one of skill in the art can "visualize or recognize" the members of the genus. We explained that an adequate written description requires a precise definition, such as by structure, formula, chemical name, physical properties, or other properties, of species falling within the genus sufficient to distinguish the genus from other materials. We have also held that functional claim language can meet the written description requirement when the art has established a correlation between structure and function. But merely drawing a fence around the outer limits of a purported genus is not an adequate substitute for describing a variety of materials constituting the genus and showing that one has invented a genus and not just a species.

...

Ariad argues that *Eli Lilly* constituted a change in the law, imposing new requirements on biotechnology inventions. We disagree. . . . Neither the statute nor legal precedent limits the written description requirement to cases of priority or distinguishes between original and amended claims. . . . Once again we reject Ariad's argument and hold that generic language in the application as filed does not automatically satisfy the written description requirement.

## F

Since its inception, this court has consistently held that § 112, first paragraph, contains a written description requirement separate from enablement, and we have articulated a "fairly uniform standard," which we now affirm. *Vas-Cath Inc. v. Mahurkar*, 935 F.2d 1555, 1562-63 (Fed. Cir. 1991). Specifically, the description must "clearly allow persons of ordinary skill in the art to recognize that the inventor invented what is claimed." In other words, the test for sufficiency is whether the disclosure of the application relied upon reasonably conveys to those skilled in the art that the inventor had possession of the claimed subject matter as of the filing date.

The term “possession,” however, has never been very enlightening. It implies that as long as one can produce records documenting a written description of a claimed invention, one can show possession. But the hallmark of written description is disclosure. Thus, “possession as shown in the disclosure” is a more complete formulation. Yet whatever the specific articulation, the test requires an objective inquiry into the four corners of the specification from the perspective of a person of ordinary skill in the art. Based on that inquiry, the specification must describe an invention understandable to that skilled artisan and show that the inventor actually invented the invention claimed.

This inquiry, as we have long held, is a question of fact. . . . [T]he level of detail required to satisfy the written description requirement varies depending on the nature and scope of the claims and on the complexity and predictability of the relevant technology. For generic claims, we have set forth a number of factors for evaluating the adequacy of the disclosure, including “the existing knowledge in the particular field, the extent and content of the prior art, the maturity of the science or technology, [and] the predictability of the aspect at issue.”

The law must be applied to each invention at the time it enters the patent process, for each patented advance has a novel relationship with the state of the art from which it emerges. Thus, we do not try here to predict and adjudicate all the factual scenarios to which the written description requirement could be applied. Nor do we set out any bright-line rules governing, for example, the number of species that must be disclosed to describe a genus claim, as this number necessarily changes with each invention, and it changes with progress in a field. Thus, whatever inconsistencies may appear to some to exist in the application of the law, those inconsistencies rest not with the legal standard but with the different facts and arguments presented to the courts.

There are, however, a few broad principles that hold true across all cases. We have made clear that the written description requirement does not demand either examples or an actual reduction to practice; a constructive reduction to practice that in a definite way identifies the claimed invention can satisfy the written description requirement. Conversely, we have repeatedly stated that actual “possession” or reduction to practice outside of the specification is not enough. Rather, as stated above, it is the specification itself that must demonstrate possession. And while the description requirement does not demand any particular form of disclosure, or that the specification recite the claimed invention *in haec verba*, a description that merely renders the invention obvious does not satisfy the requirement.

We also reject the characterization, cited by Ariad, of the court’s written description doctrine as a “super enablement” standard for chemical and biotechnology inventions. The doctrine never created a heightened requirement to provide a nucleotide-by-nucleotide recitation of the entire genus of claimed genetic material; it has always



## DISCLOSURE

expressly permitted the disclosure of structural features common to the members of the genus. It also has not just been applied to chemical and biological inventions.

Perhaps there is little difference in some fields between describing an invention and enabling one to make and use it, but that is not always true of certain inventions, including chemical and chemical-like inventions. Thus, although written description and enablement often rise and fall together, requiring a written description of the invention plays a vital role in curtailing claims that do not require undue experimentation to make and use, and thus satisfy enablement, but that have not been invented, and thus cannot be described. For example, a propyl or butyl compound may be made by a process analogous to a disclosed methyl compound, but, in the absence of a statement that the inventor invented propyl and butyl compounds, such compounds have not been described and are not entitled to a patent.

The written description requirement also ensures that when a patent claims a genus by its function or result, the specification recites sufficient materials to accomplish that function—a problem that is particularly acute in the biological arts. . . .

### Context & Application

1. What tools of statutory interpretation does the Federal Circuit use in *Ariad*? Notice here that, as with patentable subject matter, the court relies heavily on cases decided over a century ago. What inferences can we draw from this pattern?

2. In this case, Eli Lilly suggests that *Morse* was a written description case. Do you agree?

3. To reach its conclusion in *Ariad*, the Federal Circuit relies in part on *Ariad*'s admission that a separate written description requirement had "been the law for over forty years" and expressed concern about upsetting "the settled expectations of the inventing and investing communities." But what if those expectations were based on case law that clearly misinterpreted the statute? Would courts really have to, as the Federal Circuit suggests here, wait for Congress to change the law? Alternatively, what if the "inventing and investing communities" had expectations based on rules promulgated by the USPTO? Those rules do not have the force of law and are not entitled to deference from the courts. Based on the reasoning in *Ariad*, should courts defer to them anyway if they've been in place for 40 years? What about 30 years? Twenty? How long is enough for "settled expectations" to develop, with respect to either USPTO rules or Federal Circuit case law?

4. So far, we have focused mainly on the law established in *Ariad*. But what about the underlying dispute? As the court explained:

The [asserted] claims are genus claims, encompassing the use of all substances that achieve the desired result of reducing the binding of [a particular protein whose structure and function was discovered by the inventors] to [that protein's] recognition sites [on DNA molecules . . . . The specification also hypothesizes three types of molecules with the potential to reduce [the protein's] activity in cells: decoy, dominantly interfering, and specific inhibitor molecules.

...

Specific inhibitors are molecules that are 'able to block (reduce or eliminate) [the protein's] binding' to DNA in the nucleus. . . .

Dominantly interfering molecules are 'a truncated form of the [protein] ... [that] would block [the actual protein] from inducing the expression of its target genes.

...

Decoy molecules are 'designed to mimic a region of the gene whose expression would normally be induced by [the protein, leading the protein to] bind the decoy, and thus, not be available to bind its natural target. . . .

...

The '516 patent discloses no working or even prophetic examples of methods that reduce [the protein's] activity, and no completed syntheses of any of the molecules prophesized to be capable of reducing [that] activity. The state of the art at the time of filing was primitive and uncertain, leaving Ariad with an insufficient supply of prior art knowledge with which to fill the gaping holes in its disclosure. . . .

[W]e hold that the asserted claims of the '516 patent are invalid for lack of written description . . . .

So, what did Ariad actually invent or discover? What was wrong with its patent?

### C. Definiteness

Section 112(b) requires a specification to "conclude with one or more claims particularly pointing out and distinctly claiming the subject matter which the inventor or a joint inventor regards as the invention." But just how particular and distinct does a patent claim have to be? This section will explore this requirement, generally referred to as "definiteness." The Supreme Court set the contemporary standard for definiteness in its 2014 decision in *Nautilus, Inc. v. Biosig Instruments, Inc.* But before we read that case, let's see how at least one Federal Circuit panel interpreted and applied the definiteness standard pre-*Nautilus*.

DISCLOSURE

*Datamize, LLC v. Plumtree Software, Inc.*  
417 F.3d 1342 (2005)

PROST, Circuit Judge.

Datamize, L.L.C. (“Datamize”) appeals from a decision . . . holding each claim of United States Patent No. 6,014,137 (“the ‘137 patent”) invalid as indefinite under 35 U.S.C. § 112, ¶ 2. We affirm.

*Background*

A

The ‘137 patent, entitled “Electronic Kiosk Authoring System,” discloses a software program that allows a person to author user interfaces for electronic kiosks. “The authoring system enables the user interface for each individual kiosk to be customized quickly and easily within wide limits of variation, yet subject to constraints adhering the resulting interface to good standards of aesthetics and user friendliness.”

The authoring system gives the system author a limited range of pre-defined design choices for stylistic and functional elements appearing on the screens. “Major aesthetic or functional design choices as well as hierarchical methods of retrieving information may be built into the system while taking into account the considered opinions of aesthetic design specialists, database specialists, and academic studies on public access kiosk systems and user preferences and problems.”

...

At issue in this appeal is the definiteness of “aesthetically pleasing” as it is used in the context of claim 1 of the ‘137 patent.

The “aesthetically pleasing” claim language was not discussed by the inventor or the patent examiner during prosecution of the application that led to the ‘137 patent. The language was discussed, however, during prosecution of a continuation application to the ‘137 patent, which eventually issued as United States Patent No. 6,460,040 (“the ‘040 patent”). The patent examiner reviewing the application leading to the ‘040 patent rejected a claim as being indefinite for using the phrase “aesthetically pleasing.” In response to this rejection, the inventor argued that the phrase is definite, but ultimately deleted it, stating in part that it is “not intended to identify qualities separate and apart from the remainder of this claim element” and is “superfluous and unnecessary.”

## CHAPTER 5

### B

Datamize sued Plumtree Software, Inc. (“Plumtree”) for infringing the ’137 patent, and Plumtree responded by moving for summary judgment on the ground that the ’137 patent is invalid for indefiniteness under 35 U.S.C. § 112, ¶ 2. . . .

Concluding that the phrase “aesthetically pleasing” in claim 1 is “hopelessly indefinite,” the district court granted Plumtree’s motion for summary judgment of invalidity. Since claim 1 is the ’137 patent’s sole independent claim, the court’s grant of summary judgment of indefiniteness as to claim 1 invalidated each claim in the ’137 patent.

Datamize appeals the grant of summary judgment of invalidity for indefiniteness. We have jurisdiction under 28 U.S.C. § 1295(a)(1).

### *Discussion*

#### A

“A determination of claim indefiniteness is a legal conclusion that is drawn from the court’s performance of its duty as the construer of patent claims.” Thus, . . . we exercise *de novo* review over the conclusion that a claim is indefinite under 35 U.S.C. § 112, ¶ 2.

#### B

[T]he purpose of the definiteness requirement is to ensure that the claims delineate the scope of the invention using language that adequately notifies the public of the patentee’s right to exclude.

According to the Supreme Court, “the statutory requirement of particularity and distinctness in claims is met only when the claims clearly distinguish what is claimed from what went before in the art and clearly circumscribe what is foreclosed from future enterprise.” The definiteness requirement, however, does not compel absolute clarity. Only claims “not amenable to construction” or “insolubly ambiguous” are indefinite. Thus, the definiteness of claim terms depends on whether those terms can be given any reasonable meaning. Furthermore, a difficult issue of claim construction does not ipso facto result in a holding of indefiniteness. “If the meaning of the claim is discernible, even though the task may be formidable and the conclusion may be one over which reasonable persons will disagree, we have held the claim sufficiently clear to avoid invalidity on indefiniteness grounds.” In this regard it is important to note that an issued patent is entitled to a statutory presumption of validity. *See* 35 U.S.C. § 282. “By finding claims indefinite only if reasonable efforts at claim construction prove futile, we accord respect to the statutory presumption of validity and we protect the inventive contribution of patentees, even when the drafting of their patents has been less than ideal.” In this way

## DISCLOSURE

we also follow the requirement that clear and convincing evidence be shown to invalidate a patent.

...

### C

With these principles in mind, we proceed to the question at hand: whether the '137 patent's use of "aesthetically pleasing" meets the standards articulated in our case law concerning definiteness. We begin our analysis by noting our agreement with the district court's understanding that the ordinary meaning of "aesthetically pleasing" includes "having beauty that gives pleasure or enjoyment" or, in other words, "beautiful." We also recognize that the district court's opinion presents a reasoned and detailed analysis of both the intrinsic evidence, including the specification of the '137 patent and the prosecution history of the '040 patent, and the extrinsic evidence in the form of Datamize's expert testimony. Datamize, however, argues that the district court erred by considering the phrase "aesthetically pleasing" divorced from the context of claim 1.

Datamize is right to point out that the phrase "aesthetically pleasing" should be considered in the context of claim 1. . . . "Aesthetically pleasing" is used three times in claim 1. The first use of "aesthetically pleasing" relates to the look and feel of custom interface screens on kiosks:

providing a plurality of pre-defined interface screen element types, each element type defining a form of element available for presentation on said custom interface screens, wherein each said element type permits limited variation in its on-screen characteristics in conformity with a desired uniform and aesthetically pleasing look and feel for said interface screens on all kiosks of said kiosk system,

The second use relies on the first use for antecedent basis and similarly relates to the look and feel of interface screens:

each element type having a plurality of attributes associated therewith, wherein each said element type and its associated attributes are subject to pre-defined constraints providing element characteristics in conformance with said uniform and aesthetically pleasing look and feel for said interface screens,

The third use provides a slightly different context, relating to the aggregate layout of elements on the interface screen:

assigning values to the attributes associated with each of said selected elements consistent with said pre-defined constraints, whereby the aggregate layout of said plurality of selected elements on said interface screen under construction will be aesthetically pleasing and functionally operable for effective delivery of information to a kiosk user;

Thus, in the context of claim 1, “aesthetically pleasing” relates to the look and feel of custom interface screens on kiosks, and the aggregate layout of elements on an interface screen is apparently one example or aspect of the interface screens that may be “aesthetically pleasing.”

This context, while helpful in terms of identifying the components of the claimed invention that must be “aesthetically pleasing,” does not suggest or provide any meaningful definition for the phrase “aesthetically pleasing” itself. Merely understanding that “aesthetically pleasing” relates to the look and feel of interface screens, or more specifically to the aggregate layout of elements on interface screens, fails to provide one of ordinary skill in the art with any way to determine whether an interface screen is “aesthetically pleasing.”

Datamize, however, contends that when construed in the context of claim 1, the phrase “aesthetically pleasing” applies to the process of defining a “desired” result and not the actual result itself. Datamize believes a reasonable construction of “aesthetically pleasing” in the context of the claims involves the intent, purpose, wish, or goal of a person practicing the invention: that person simply must intend to create an “aesthetically pleasing” interface screen; whether that person actually succeeds is irrelevant. In other words, Datamize suggests we adopt a construction of “aesthetically pleasing” that only depends on the subjective opinion of a person selecting features to be included on an interface screen. Indeed, Datamize argues that the district court erred by requiring an objective definition for the phrase “aesthetically pleasing.” Citing our decision in *Orthokinetics, Inc. v. Safety Travel Chairs, Inc.*, 806 F.2d 1565, 1575–76 (Fed. Cir. 1986), Datamize maintains that a claim term need not be subject to a single, objective definition to be definite but rather may include a subjective element. According to Datamize, subjective terms are permissible so long as one of ordinary skill in the art would understand their scope. In this regard, Datamize implies that “aesthetically pleasing” includes “words of degree” that are not fatally imprecise. Datamize also contends that the existence of aesthetic constraints in a computer program, as opposed to purely functional constraints, would be circumstantial evidence of a person’s subjective “desire” to achieve an “aesthetically pleasing” look and feel for an interface screen. Related to these arguments, Datamize believes that the person practicing the invention is the “system creator,” defined by Datamize as the person who creates the authoring software. According to Datamize, the appropriate inquiry would focus on whether a system creator makes aesthetic choices to limit or constrain the possible on-screen characteristics of screen elements since these choices would reflect a subjective intent to create an “aesthetically pleasing” look and feel for an interface screen.

Datamize’s proposed construction of “aesthetically pleasing” in the context of claim 1 is not reasonable for several reasons. First and foremost, the plain meaning of the claim

## DISCLOSURE

language requires that the look and feel of interface screens actually be “aesthetically pleasing.” The first use of “aesthetically pleasing” in claim 1 clearly sets forth two requirements for the look and feel of interface screens: the look and feel must be (1) uniform and (2) “aesthetically pleasing.” That the uniform and “aesthetically pleasing” look and feel must also be “desired” does not alter that fact.

Furthermore, in *Orthokinetics* we did not conclude, as Datamize suggests, that the absence of an objective definition for a claim term does not render the phrase indefinite. In that case we concluded that the phrase “so dimensioned” in the following limitation is not indefinite: “wherein said front leg portion is so dimensioned as to be insertable through the space between the doorframe of an automobile and one of the seats thereof.” We noted that based on expert testimony it was undisputed that one of ordinary skill in the art would easily have been able to determine the appropriate dimensions that the claim language required. One desiring to build and use the invention, a travel chair, “must measure the space between the selected automobile's doorframe and its seat and then dimension the front legs of the travel chair so they will fit in that particular space in that particular automobile.” The fact that the claims were intended to cover the use of the invention with various types of automobiles made no difference; we concluded that the phrase “so dimensioned” is as accurate as the subject matter permits since automobiles are of various sizes. Thus, in *Orthokinetics* we recognized that an objective definition encompassed by the claim term “so dimensioned” could be applied to innumerable specific automobiles.

In stark contrast to *Orthokinetics*, here Datamize has offered no objective definition identifying a standard for determining when an interface screen is “aesthetically pleasing.” In the absence of a workable objective standard, “aesthetically pleasing” does not just include a subjective element, it is completely dependent on a person’s subjective opinion. To the extent Datamize argues that such a construction of “aesthetically pleasing” does not render the phrase indefinite, we disagree. The scope of claim language cannot depend solely on the unrestrained, subjective opinion of a particular individual purportedly practicing the invention. Some objective standard must be provided in order to allow the public to determine the scope of the claimed invention. Even if the relevant perspective is that of the system creator, the identity of who makes aesthetic choices fails to provide any direction regarding the relevant question of how to determine whether that person succeeded in creating an “aesthetically pleasing” look and feel for interface screens. A purely subjective construction of “aesthetically pleasing” would not notify the public of the patentee’s right to exclude since the meaning of the claim language would depend on the unpredictable vagaries of any one person’s opinion of the aesthetics of interface screens. While beauty is in the eye of the beholder, a claim term, to be definite,

requires an objective anchor. Thus, even if we adopted a completely subjective construction of “aesthetically pleasing,” this would still render the ’137 patent invalid.

...

Datamize also argues that one of ordinary skill in the art would understand the phrase “aesthetically pleasing” to distinguish aesthetic constraints from purely functional constraints. To support this argument, Datamize first points to the Supreme Court’s use of the phrase “aesthetically pleasing”: “to qualify for design patent protection, a design must present an *aesthetically pleasing* appearance that is not dictated by function alone, and must satisfy the other criteria of patentability.” *Bonito Boats, Inc. v. Thunder Craft Boats, Inc.*, 489 U.S. 141, 148 (1989). According to Datamize, “if the term ‘aesthetically pleasing’ is sufficiently definite for courts to apply in determining whether something qualifies for design patent protection, then it is also sufficiently definite for a trier of fact to apply in determining infringement.” Datamize also points to Mr. Rosenblatt’s declaration, which it believes shows that one of ordinary skill in the art would understand “aesthetically pleasing” to distinguish functionality from aesthetics. Datamize maintains that infringement could be shown by looking to constraints imposed by the system creator: aesthetic constraints, such as limitations in terms of size and placement of on-screen elements, would be objective evidence of the infringer’s “desire” to achieve a “uniform and aesthetically pleasing look and feel.”

We reject Datamize’s attempt to rely on an understanding of the phrase “aesthetically pleasing” derived from design patent law. Use of the phrase “aesthetically pleasing” in design patent law relates to the threshold question of patentability. *See Bonito Boats*, 489 U.S. at 148. A design patent protects a particular ornamental, or “aesthetically pleasing” as opposed to functional, design. In contrast, a utility patent protects “any new and useful process, machine, manufacture, or composition of matter, or any new and useful improvement thereof,” 35 U.S.C. § 101, the scope of which is defined by the patent’s written claims. In light of this basic difference between design patent law and utility patent law, it is clear that the understanding of “aesthetically pleasing” used in design patent law bears no reasonable relationship to utility patent law generally. Furthermore, Datamize has not pointed to any discussion in the ’137 patent indicating that “aesthetically pleasing” means “aesthetic rather than functional” as opposed to its ordinary meaning of beautiful in the context of this patent in particular. Thus, while creative, Datamize’s argument fails.

We also reject Datamize’s more general argument, based on its expert’s declaration, that one of ordinary skill in the art would understand the phrase “aesthetically pleasing” to distinguish aesthetic constraints from purely functional constraints. Datamize’s argument, as well as its citation to its expert’s declaration, improperly ignores the plain meaning of the claim language. Furthermore, its proposed construction would



## DISCLOSURE

improperly eliminate the word “pleasing” from the phrase “aesthetically pleasing.” We would subvert the definiteness requirement if we allowed a word to be eliminated from a phrase when the phrase cannot be given a reasonable meaning except in the absence of that word. Furthermore, because the phrase “aesthetically pleasing” does not simply distinguish aesthetic constraints from purely functional constraints, *Datamize*’s argument, again based on its expert’s declaration, that infringement could be shown by determining whether aesthetic constraints are imposed by the system creator is irrelevant.

### *Conclusion*

“Aesthetically pleasing,” as it is used in the only independent claim of the ’137 patent, fails to “particularly point out and distinctly claim the subject matter which the patentee regards as his invention.” We therefore affirm the district court’s grant of summary judgment of invalidity of all claims of the ’137 patent.

### Context & Application

1. How does the requirement of definiteness further the goals of patent law?
2. In *Datamize*, the challenged claim was deemed indefinite under the “insolubly ambiguous” test. How often do you think that happened? In other words, do you think the outcome in *Datamize* was typical or an outlier? Was “not insolubly ambiguous” a difficult standard for patent drafters to meet?
3. The court tells us that during the prosecution of the ’040 patent, the inventor deleted the phrase “aesthetically pleasing” because it was “not intended to identify qualities separate and apart from the remainder of this claim element” and was “superfluous and unnecessary.” If that is true, why do you think that language was included in the first place?
4. In a famous copyright case, the Supreme Court said that “it would be a dangerous undertaking for persons trained only to the law to constitute themselves final judges of the worth of pictorial illustrations, outside of the narrowest and most obvious limits.” *Bleistein v. Donaldson Lithographing Co.*, 188 U.S. 239, 251 (1903). Is *Datamize* an example of this “aesthetic nondiscrimination” principle? Or is there something else going on?
5. Was the invention claimed in *Datamize* “useful” under § 101? Is it the kind of innovation that should be protected by utility patents or would it fit better in a different regime, such as copyright or design patent?
6. In *Datamize*, the Federal Circuit also suggests that “aesthetically pleasing” (or “ornamental”) is the opposite of “functional.” Do you agree? Can you think of any examples of visual designs that are both aesthetically appealing *and* functional?

7. One word of warning: Neither *Datamize* nor the Federal Circuit gets design patent law quite right in this decision. Despite the quoted *dicta* from *Bonito Boats*, designs are not currently required to be “aesthetically pleasing” to get a design patent. *Seiko Epson Corp. v. Nu-Kote Int’l, Inc.*, 190 F.3d 1360, 1368 (Fed. Cir. 1999) (“Nor need the design be aesthetically pleasing. The ‘ornamental’ requirement of the design statute means that the design must not be governed solely by function, i.e., that this is not the only possible form of the article that could perform its function.”). For more on this topic, *see* Chapter 12.

8. In *Datamize*, the Federal Circuit also says that “the purpose of the definiteness requirement is to ensure that the claims delineate the scope of the invention using language that adequately notifies the public of the patentee’s right to exclude.” Who does (or should) count as the relevant “public” here? If “public” means “the general consuming public of the United States,” *cf.* 15 U.S.C. § 1125(c)(2)(A), the court could require the parties to go out and do surveys to determine what regular people think about the patent claims. But as you’ve seen, that’s not what courts do. What does that tell us about who the relevant “public” might be in this context? What “public” should patent law care about?

*Nautilus, Inc. v. Biosig Instruments, Inc.*  
572 U.S. 898 (2014)

Justice GINSBURG delivered the opinion of the Court.

The Patent Act requires that a patent specification “conclude with one or more claims particularly pointing out and distinctly claiming the subject matter which the applicant regards as the invention.” 35 U.S.C. § 112, ¶ 2. This case, involving a heart-rate monitor used with exercise equipment, concerns the proper reading of the statute’s clarity and precision demand. According to the Federal Circuit, a patent claim passes the § 112, ¶ 2 threshold so long as the claim is “amenable to construction,” and the claim, as construed, is not “insolubly ambiguous.” We conclude that the Federal Circuit’s formulation, which tolerates some ambiguous claims but not others, does not satisfy the statute’s definiteness requirement. In place of the “insolubly ambiguous” standard, we hold that a patent is invalid for indefiniteness if its claims, read in light of the specification delineating the patent, and the prosecution history, fail to inform, with reasonable certainty, those skilled in the art about the scope of the invention. Expressing no opinion on the validity of the patent-in-suit, we remand, instructing the Federal Circuit to decide the case employing the standard we have prescribed.

I

Authorized by the Constitution “to promote the Progress of Science and useful Arts, by securing for limited Times to Inventors the exclusive Right to their Discoveries,” Art. I,

## DISCLOSURE

§ 8, cl. 8, Congress has enacted patent laws rewarding inventors with a limited monopoly. “That monopoly is a property right,” and “like any property right, its boundaries should be clear.” Thus, when Congress enacted the first Patent Act in 1790, it directed that patent grantees file a written specification “containing a description of the thing or things invented or discovered,” which “shall be so particular” as to “distinguish the invention or discovery from other things before known and used.”

The patent laws have retained this requirement of definiteness even as the focus of patent construction has shifted. Under early patent practice in the United States, we have recounted, it was the written specification that “represented the key to the patent.” Eventually, however, patent applicants began to set out the invention’s scope in a separate section known as the “claim.” The Patent Act of 1870 expressly conditioned the receipt of a patent on the inventor’s inclusion of one or more such claims, described with particularity and distinctness.

The 1870 Act’s definiteness requirement survives today, largely unaltered. Section 112 of the Patent Act of 1952, applicable to this case, requires the patent applicant to conclude the specification with “one or more claims particularly pointing out and distinctly claiming the subject matter which the applicant regards as his invention.” 35 U.S.C. § 112, ¶ 2. A lack of definiteness renders invalid “the patent or any claim in suit.” § 282, ¶ 2.

## II

### A

The patent in dispute, U.S. Patent No. 5,337,753 (“753 patent”), issued to Dr. Gregory Lekhtman in 1994 and assigned to respondent Biosig Instruments, Inc., concerns a heart-rate monitor for use during exercise. Previous heart-rate monitors, the patent asserts, were often inaccurate in measuring the electrical signals accompanying each heartbeat (electrocardiograph or ECG signals). The inaccuracy was caused by electrical signals of a different sort, known as electromyogram or EMG signals, generated by an exerciser’s skeletal muscles when, for example, she moves her arm, or grips an exercise monitor with her hand. These EMG signals can “mask” ECG signals and thereby impede their detection.

Dr. Lekhtman’s invention claims to improve on prior art by eliminating that impediment. The invention focuses on a key difference between EMG and ECG waveforms: while ECG signals detected from a user’s left hand have a polarity opposite to that of the signals detected from her right hand, EMG signals from each hand have the same polarity. The patented device works by measuring equalized EMG signals detected at each hand and then using circuitry to subtract the identical EMG signals from each other, thus filtering out the EMG interference.

As relevant here, the '753 patent describes a heart-rate monitor contained in a hollow cylindrical bar that a user grips with both hands, such that each hand comes into contact with two electrodes, one "live" and one "common." The device is illustrated in figure 1 of the patent, reproduced in the Appendix to this opinion.

Claim 1 of the '753 patent, which contains the limitations critical to this dispute, refers to a "heart rate monitor for use by a user in association with exercise apparatus and/or exercise procedures." The claim "comprises," among other elements, an "elongate member" (cylindrical bar) with a display device; "electronic circuitry including a difference amplifier"; and, on each half of the cylindrical bar, a live electrode and a common electrode "mounted in spaced relationship with each other." The claim sets forth additional elements, including that the cylindrical bar is to be held in such a way that each of the user's hands "contacts" both electrodes on each side of the bar. Further, the EMG signals detected by the two electrode pairs are to be "of substantially equal magnitude and phase" so that the difference amplifier will "produce a substantially zero EMG signal" upon subtracting the signals from one another.

## B

The dispute between the parties arose in the 1990's, when Biosig allegedly disclosed the patented technology to StairMaster Sports Medical Products, Inc. According to Biosig, StairMaster, without ever obtaining a license, sold exercise machines that included Biosig's patented technology, and petitioner Nautilus, Inc., continued to do so after acquiring the StairMaster brand. In 2004, based on these allegations, Biosig brought a patent infringement suit against Nautilus in the U.S. District Court for the Southern District of New York.

. . . The District Court ultimately construed the term to mean "there is a defined relationship between the live electrode and the common electrode on one side of the cylindrical bar and the same or a different defined relationship between the live electrode and the common electrode on the other side of the cylindrical bar," without any reference to the electrodes' width.

Nautilus moved for summary judgment, arguing that the term "spaced relationship," as construed, was indefinite under § 112, ¶ 2. The District Court granted the motion. Those words, the District Court concluded, "did not tell the court or anyone what precisely the space should be," or even supply "any parameters" for determining the appropriate spacing.

The Federal Circuit reversed and remanded. A claim is indefinite, the majority opinion stated, "only when it is 'not amenable to construction' or 'insolubly ambiguous.'" Under that standard, the majority determined, the '753 patent survived indefiniteness review.

## DISCLOSURE

### III

#### A

Although the parties here disagree on the dispositive question—does the '753 patent withstand definiteness scrutiny—they are in accord on several aspects of the § 112, ¶ 2 inquiry. First, definiteness is to be evaluated from the perspective of someone skilled in the relevant art. Second, in assessing definiteness, claims are to be read in light of the patent's specification and prosecution history. Third, "definiteness is measured from the viewpoint of a person skilled in [the] art at the time the patent was filed."

The parties differ, however, in their articulations of just how much imprecision § 112, ¶ 2 tolerates. In *Nautilus*' view, a patent is invalid when a claim is "ambiguous, such that readers could reasonably interpret the claim's scope differently." *Biosig* and the Solicitor General would require only that the patent provide reasonable notice of the scope of the claimed invention.

Section 112, we have said, entails a "delicate balance." On the one hand, the definiteness requirement must take into account the inherent limitations of language. Some modicum of uncertainty, the Court has recognized, is the "price of ensuring the appropriate incentives for innovation." One must bear in mind, moreover, that patents are "not addressed to lawyers, or even to the public generally," but rather to those skilled in the relevant art.

At the same time, a patent must be precise enough to afford clear notice of what is claimed, thereby "apprising the public of what is still open to them." Otherwise there would be "a zone of uncertainty which enterprise and experimentation may enter only at the risk of infringement claims." And absent a meaningful definiteness check, we are told, patent applicants face powerful incentives to inject ambiguity into their claims.

To determine the proper office of the definiteness command, therefore, we must reconcile concerns that tug in opposite directions. Cognizant of the competing concerns, we read § 112, ¶ 2 to require that a patent's claims, viewed in light of the specification and prosecution history, inform those skilled in the art about the scope of the invention with reasonable certainty. The definiteness requirement, so understood, mandates clarity, while recognizing that absolute precision is unattainable. The standard we adopt accords with opinions of this Court stating that "the certainty which the law requires in patents is not greater than is reasonable, having regard to their subject-matter."

#### B

In resolving *Nautilus*' definiteness challenge, the Federal Circuit asked whether the '753 patent's claims were "amenable to construction" or "insolubly ambiguous." Those formulations can breed lower court confusion . . . . It cannot be sufficient that a court can

ascribe some meaning to a patent’s claims; the definiteness inquiry trains on the understanding of a skilled artisan at the time of the patent application, not that of a court viewing matters *post hoc*. To tolerate imprecision just short of that rendering a claim “insolubly ambiguous” would diminish the definiteness requirement’s public-notice function and foster the innovation-discouraging “zone of uncertainty,” against which this Court has warned.

Appreciating that “terms like ‘insolubly ambiguous’ may not be felicitous,” Biosig argues the phrase is a shorthand label for a more probing inquiry that the Federal Circuit applies in practice. The Federal Circuit’s fuller explications of the term “insolubly ambiguous,” we recognize, may come closer to tracking the statutory prescription. But although this Court does not “micromanage the Federal Circuit’s particular word choice” in applying patent-law doctrines, we must ensure that the Federal Circuit’s test is at least “probative of the essential inquiry.” Falling short in that regard, the expressions “insolubly ambiguous” and “amenable to construction” permeate the Federal Circuit’s recent decisions concerning § 112, ¶ 2’s requirement. We agree with *Nautilus* and its amici that such terminology can leave courts and the patent bar at sea without a reliable compass.

...

For the reasons stated, we vacate the judgment of the United States Court of Appeals for the Federal Circuit and remand the case for further proceedings consistent with this opinion.

It is so ordered.

### Context & Application

1. How—and if so, how much—did *Nautilus* actually change the law? One way to think about this: Do you think *Datamize* would (or should) come out differently if it were decided today?

2. Is definiteness a question of law or fact? The Federal Circuit says it “is a question of law that we review *de novo*, subject to a determination of underlying facts, which we review for substantial evidence.” *Guangdong Alison Hi-Tech Co. v. Int’l Trade Comm’n*, 936 F.3d 1353, 1359 (Fed. Cir. 2019). How does that compare to enablement and written description?

3. In *Nautilus*, the Court states that some level of uncertainty must be tolerated in patent claims due to “the inherent limitations of language.” But what if inventions weren’t claimed using words? What if certain types of inventions were claimed using models? Or pictures? Could—and should—we require more certainty then?

## DISCLOSURE

4. In *Nautilus*, the Court says that “patents are not addressed to lawyers, or even to the public generally, but rather to those skilled in the relevant art.” What happens if the actual inventor doesn’t know what a claim term means? In *Leupold & Stevens, Inc. v. Lightforce USA, Inc.*, 434 F. Supp. 3d 886, 899 (D. Or. 2020), the accused infringer argued that certain claim terms were indefinite because “the inventor of the [asserted] patent admitted that he does not know how ‘transversely to’ and ‘transversely of’ differ, and does not know what ‘rotatable transversely of’ means as used in the claims.” The court rejected that argument:

As a general matter, “[i]nventor testimony, obtained in the context of litigation, should not be used to invalidate issued claims under section 112, paragraph 2.” *Solomon v. Kimberly-Clark Corp.*, 216 F.3d 1372, 1380 (Fed. Cir. 2000). Indeed, as the Federal Circuit has explained in the context of claim construction, an inventor’s testimony may be “limited by the fact that an inventor understands the invention but may not understand the claims, which are typically drafted by the attorney prosecuting the patent applications.” *Howmedica Osteonics Corp. v. Wright Med. Tech., Inc.*, 540 F.3d 1337, 1346–47 (Fed. Cir. 2008).

Remember that while an inventor is, by definition, skilled in the art, that does not mean his or her point of view is controlling. After all, the POSITA is not a real person, but a hypothetical person, like the “reasonable person” in tort law. That means we can’t go out and survey anyone to determine what a term means to a POSITA or rest determinations of indefiniteness on the perspective of any particular person—even the inventor.

### D. Best Mode

Finally, the specification must “set forth the best mode contemplated by the inventor or joint inventor of carrying out the invention.” 35 U.S.C. § 112(a). According to the Federal Circuit:

[A] proper best mode analysis has two components. The first is whether, at the time the inventor filed his patent application, he knew of a mode of practicing his claimed invention that he considered to be better than any other. This part of the inquiry is wholly subjective, and resolves whether the inventor must disclose any facts in addition to those sufficient for enablement. If the inventor in fact contemplated such a preferred mode, the second part of the analysis compares what he knew with what he disclosed—is the disclosure adequate to enable one skilled in the art to practice the best mode or, in other words, has the inventor “concealed” his preferred mode from the “public”? Assessing the adequacy of the disclosure, as opposed to its necessity, is largely an objective inquiry that depends upon the scope of the claimed invention and the level of skill in the art.

## CHAPTER 5

*Chemcast Corp. v. Arco Indus. Corp.*, 913 F.2d 923, 927–28 (Fed. Cir. 1990). Why is best-mode disclosure required? As Lee Petherbridge and Jason Rantanen explain:

The policy purpose of the best mode requirement has been something of an enigma. Courts have reasoned, and commentators have repeated, that its purpose is to allow competitors to compete fairly with the patentee following the expiration of the patent. The underlying concern is that a strategically minded patent applicant can make an enabling disclosure of an invention it has conceived and at the same time keep secret details crucial to the practice of the most commercially valuable forms of the invention. When this happens, the public receives less than it bargained for in conferring a patent, and patentees that withhold best modes might obtain a de facto extension of their patent terms, thereby distorting the incentive structure Congress imposed with the patent system.

*In Memoriam Best Mode*, 64 STAN. L. REV. ONLINE 125, 126 (2012) (footnotes omitted). Before the enactment of the AIA, many argued that the best mode requirement should be eliminated entirely:

[O]pponents cited several reasons for abolishing best mode. First, they argued that best mode “significantly increased the expense and complexity of litigation” because it required extensive discovery into the inventor’s subjective belief regarding whether she had a preferred implementation of the invention at the time of the patent application’s filing. As a result, they claimed, best mode imposed an unnecessary cost on inventors. Second, opponents contended that best mode violations were difficult to prove because the doctrine is “inherently subjective” and “the best mode contemplated at the time of the invention may not be the best mode for practicing or using the invention years later” when the patent might wind up challenged in court. Third, best mode was noted as inconsistent with international norms, as the requirement was unique to American law. This imposed a burden on foreign applicants seeking patent protection in the U.S., as well as requiring domestic inventors to make a more detailed disclosure compared to foreign inventors who did not desire U.S. patent protection.

Brian J. Love & Christopher B. Seaman, *Best Mode Trade Secrets*, 15 YALE J. L. & TECH. 1, 8–9 (2013) (footnotes omitted).

When it passed the AIA, Congress retained the best mode requirement in 35 U.S.C. § 112(a). But Congress amended 35 U.S.C. § 282(b)(3)(A) to specify that “the failure to disclose the best mode shall not be a basis on which any claim of a patent may be canceled or held invalid or otherwise unenforceable.” So:

Technically, the Act still conditions a patent’s issuance on describing any best mode in the application. However, this provision is nearly toothless. An examiner



## DISCLOSURE

who can somehow detect that an inventor knew of a preferred embodiment, but failed to adequately detail it in the application, can respond with a rejection on this ground. But once a patent issues, failure to describe best mode cannot be used to invalidate the grant.

Derek E. Bambauer, *Paths or Fences: Patents, Copyrights, and the Constitution*, 104 IOWA L. REV. 1017, 1069 (2019).

### Context & Application

1. How is best mode similar to and different from the enablement requirement?
2. What do you think of the changes Congress made to best mode in the AIA? If it was a compromise, was it a good one?
3. While courts can no longer invalidate issued patents for failure to disclose the best mode, patent examiners must still evaluate patent applications for compliance with the best mode requirement. *See* MPEP § 2165(II). How easy (or difficult) do you think it would be for a patent examiner to tell if an application complied with the standard set forth in *Chemcast*? *See* Ryan Vacca, *Patent Reform and Best Mode: A Signal to the Patent Office or A Step Toward Elimination?*, 75 ALB. L. REV. 279, 293–95 (2012) (arguing that “the risk of rejection at the PTO for failure to disclose the best mode is almost nonexistent”).



## 6. NOVELTY

In order to be patentable, an invention must be new. This requirement, generally referred to as “novelty” is codified at 35 U.S.C. § 102. The requirement that a patentee disclose something new is part of the patent bargain. According to the Supreme Court: “Congress may not authorize the issuance of patents whose effects are to remove existent knowledge from the public domain, or to restrict free access to materials already available.” *Graham v. John Deere Co.*, 383 U.S. 1, 6 (1966). Instead, patents are meant to encourage the creation and disclosure of new information, which is supposed to enter the public domain at the end of the patent term.

How do the USPTO and the courts determine if an invention is new? This inquiry can be broken down into two main questions. First, what is the date as of which the invention’s novelty is measured? While the filing date of the patent at the USPTO serves as a simple starting point for measuring novelty, in many instances the applicant can rely on other actions to establish an earlier date. Second, what are the events or materials against which the invention’s novelty is judged the invention? We call these events or materials the “prior art.” If something is “anticipated by the prior art,” it is not novel.

One important wrinkle to the novelty determination is that § 102 was amended in the 2011 America Invents Act (“AIA”). Therefore, there is a different set of novelty rules for patents with an effective filing date on or after March 16, 2013. Because patent terms run for 20 years from filing, there are patents in force that are governed by the (old) pre-AIA version of § 102 and there are other patents in force, as well as applications being filed or examined, that are governed by the (new) AIA version of § 102. Some components of pre-AIA novelty are diminishing in importance as patents governed by the pre-AIA version of § 102 expire, such as the laws and doctrines that determined who among rivals was the first to invent under 35 USC § 102(g). Other parts of the statute remain similar in content, although form and priority dates may be different.

This chapter will focus on the AIA regime, the law that applies to patents filed today. Today, section 102(a) provides:

- (a) Novelty; Prior Art— A person shall be entitled to a patent unless—
  - (1) the claimed invention was patented, described in a printed publication, or in public use, on sale, or otherwise available to the public before the effective filing date of the claimed invention; or

(2) the claimed invention was described in a patent issued under section 151, or in an application for patent published or deemed published under section 122 (b), in which the patent or application, as the case may be, names another inventor and was effectively filed before the effective filing date of the claimed invention.

Even though the statutory language is new, older cases are still relevant to how the AIA is interpreted. For example, the principle that things in “public use” should not be patentable is an idea that long predates the AIA. Indeed, by the time the AIA was enacted, “public use” was a well-established term of art in patent law. When Congress uses a term of art in drafting a statute, courts generally presume that Congress knew about and adopted the specialized meaning. *See F.A.A. v. Cooper*, 566 U.S. 284, 292 (2012). Therefore, pre-AIA cases interpreting the phrase “public use”—including the two nineteenth-century cases that follow—remain relevant today.

This chapter begins with a discussion of the AIA and its determination of the novelty date and then the categories of prior art. Next, the chapter discusses exceptions to prior art before comparing novelty pre- and post-AIA.

### A. Prior Art: Timing

To determine what counts as prior art, it is necessary to assign a date to the claimed invention and a date to each piece of prior art. This section explains the timing provisions under the AIA which apply to new patent applications.

The current (AIA) version of § 102 applies to patents with an effective filing date on or after March 16, 2013. One of the goals of the AIA was to make U.S. law more consistent with foreign patent laws by switching from a system that measured novelty as of the date of invention to a system that measures novelty as of the date of filing the patent application. In other words, U.S. law has moved from a first-to-invent system to a first-to-file system of awarding priority. If two inventors simultaneously come up with the same idea, it is now ordinarily the first one to the patent office that is entitled to the patent. Patent applicants therefore generally want to claim earlier filing dates. However, “first-to-file” is not an entirely accurate description, either. As you will see, the AIA actually grants priority to the first inventor to disclose-and-then-file-within-a-year. But more on that later.

Another international piece of novelty analysis involves provisions in various international treaties, such as the TRIPS Agreement (the part of WTO Agreement that governs intellectual property standards). The TRIPS Agreement requires countries to allow patent applicants to claim priority to earlier, foreign applications. As a result, filing a patent application in one country allows a patent holder to claim that date as their

## NOVELTY

“effective filing date” in other member countries, with a year (or sometimes more) of grace period to file. When a U.S. patent application claims priority to a foreign application, it is analyzed for novelty as of its *effective* filing date, which is not necessarily the date of application in the USPTO. The AIA defines the effective filing date of an application that is not a reissue as:

(A) if subparagraph (B) does not apply, the actual filing date of the patent or the application for the patent containing a claim to the invention; or

(B) the filing date of the earliest application for which the patent or application is entitled, as to such invention, to a right of priority under section 119, 365(a), 365(b), 386(a), or 386(b) or to the benefit of an earlier filing date under section 120, 121, 365(c), or 386(c).

35 U.S.C. § 100(i). The pre-AIA novelty provisions, discussed later in this chapter, look to prior art that predates the date of invention, rather than the filing date.

One note about language: courts often discuss the day one year prior to the effective filing date as “the critical date” and, under pre-AIA caselaw, the year before the filing date was called a “grace period.” Conceptually, the idea was that an inventor had a period of time after they—or someone else—disclosed the invention to file a patent application. These terms are still used sometimes in practice and by courts, although the structure and the language of the AIA makes them an imperfect fit.

### B. Prior Art: Categories

Section 102 describes a number of different categories of prior art. Each category represents a different type of prior art. Some of these categories are more straightforward than others, as you’ll see in the cases below. Also, note that the two paragraphs of § 102(a) differ on the date as of which references are counted as prior art. So, the categories listed in § 102(a)(1) are printed publications, public use, on sale, or otherwise available to the public. These count as prior art as of the date of publication, use, or sale when those happen “before the effective filing date of the claimed invention.” But § 102(a)(2) is different. It covers patents or published patent applications *filed* any time prior to the applicant’s effective filing date, even though they may only be published or issue later. That means that sometimes, these applications are only made public after the patent applicant has filed for a patent. In a sense, then, the types of prior art listed in § 102(a)(2) aren’t *publicly known* prior to the applicant’s filing. We turn to the various types of prior art now.

## 1. Patented or Described in a Printed Publication

The first categories of prior art identified by § 102(a)(1) are patents and printed publications. For printed publications, the inquiry can include a determination of whether something is (1) printed and (2) published.

*Medtronic, Inc. v. Barry*  
891 F.3d 1368 (Fed. Cir. 2018)

CHEN, Circuit Judge.

This is a consolidated appeal from two related decisions of the U.S. Patent and Trademark Office’s Patent Trial and Appeals Board in inter partes review (IPR) proceedings. The Board concluded that the petitioner, Medtronic, Inc., had not proven that the challenged patent claims are unpatentable.

We affirm-in-part and vacate-in-part. Substantial evidence supports the Board’s determination that the challenged claims would not have been [invalid] over two references: (1) U.S. Patent Application No. 2005/0245928 (the ‘928 Application); and (2) a book chapter which appears in *MASTERS TECHNIQUES IN ORTHOPAEDIC SURGERY: THE SPINE* (2d ed.) (MTOS). However, we vacate the Board’s conclusion that certain other references, i.e., a video entitled “Thoracic Pedicle Screws for Idiopathic Scoliosis” and slides entitled “Free Hand Thoracic Screw Placement and Clinical Use in Scoliosis and Kyphosis Surgery” (Video and Slides), were not prior art because the Board did not fully consider all the factors for determining whether the Video and Slides were publicly accessible. We thus remand for further proceedings.

### *Background*

Medtronic manufactures surgical systems and tools used in spinal surgeries. In February 2014, spine surgeon Dr. Mark Barry sued Medtronic for patent infringement in the Eastern District of Texas. Barry alleged that Medtronic’s products infringed a group of Barry’s patents, including U.S. Patent Nos. 7,670,358 (the ‘358 Patent) and 7,776,072 (the ‘072 Patent). Medtronic then petitioned for, and the Board instituted, IPR proceedings for all claims in both patents.

...

Medtronic submitted the following prior art references relevant to the issues raised in this appeal: (1) the ‘928 Application; (2) MTOS; and (3) Video and Slides. . . .

Medtronic distributed a video demonstration and a related slide presentation to spinal surgeons at various industry meetings and conferences in 2003. These video and slide sets

## NOVELTY

depict derotation surgeries that use pedicle screws and other instrumentation to correct scoliosis. The Video consists of a narrated derotation surgery performed in 2001 by Dr. Lenke, who testified as Medtronic's expert in this case. The Slides include information about the use of pedicle screws in derotation surgeries, including numerous pictures from surgeries performed and x-rays of preoperative and post-operative spines. The Board found that the Video and Slides, although presented at three different meetings in 2003, were not publicly accessible and therefore were not "printed publications," in accordance with 35 U.S.C. § 102.2. As a result, the Board, in its final decisions, refused to consider these materials as prior art in its evaluation of the '358 and '072 Patents.

### *Discussion*

On appeal, the parties dispute whether the Video and Slides constitute printed publications within the meaning of [the pre-AIA version of] § 102.

A CD containing the Video was distributed at three separate programs in 2003: (1) a meeting of the "Spinal Deformity Study Group" (SDSG) in Scottsdale, Arizona, on April 10-13, 2003 (the Scottsdale program); (2) the Advanced Concepts in Spinal Deformity Surgery meeting in Colorado Springs, Colorado, on May 18-19, 2003 (the Colorado Springs program); and (3) the Spinal Deformity Study Symposium meeting in St. Louis, Missouri, on November 13-15, 2003 (the St. Louis program). Binders containing relevant portions of the Slides were also distributed at the Colorado Springs and St. Louis programs.

The earliest of the three 2003 programs, the Scottsdale program, was limited to SDSG members. Medtronic's witness, David Poley, described SDSG as "a gathering of experts within the field of spinal deformity." About 20 SDSG members attended the Scottsdale program. The other two programs were open to other surgeons. Medtronic sponsored these programs as medical education courses. Approximately 20 and 55 surgeons attended the Colorado Springs and St. Louis programs, respectively.

Medtronic argues that the Board committed legal error in concluding that the Video and Slides were not sufficiently accessible to the public. According to Medtronic, the Board's sole basis for this conclusion rested on its faulty assumption that the materials were distributed only to members of the SDSG. Medtronic points out two problems with this assumption. First, it argues that the Board improperly ignored evidence that the Video and Slides were distributed at programs that were not limited to SDSG members. Second, Medtronic contends that, even if the assumption were correct, a reference need only be accessible to the "interested public" to satisfy the public accessibility requirement, and that, members of the SDSG fall squarely within that category.

According to Barry, the Board correctly found that "members of the Spinal Deformity Study Group, who received the Video and Slides, were experts voted into membership by

an executive board based on their qualifications and ability to conduct research.” Because the slides were only available to experts who are part of a group limited to members only, and not those of ordinary skill, Barry argues that the Video and Slides were not publicly accessible to ordinarily skilled artisans.

... “The printed publication provision of § 102(b) was designed to prevent withdrawal by an inventor of that which was already in the possession of the public.” ...

The determination of whether a document is a “printed publication” under 35 U.S.C. § 102(b) “involves a case-by-case inquiry into the facts and circumstances surrounding the reference’s disclosure to members of the public.” *In re Klopfenstein*, 380 F.3d 1345, 1350 (Fed. Cir. 2004). “Because there are many ways in which a reference may be disseminated to the interested public, ‘public accessibility’ has been called the touchstone in determining whether a reference constitutes a ‘printed publication’ bar under 35 U.S.C. § 102(b).” “A reference will be considered publicly accessible if it was ‘disseminated or otherwise made available to the extent that persons interested and ordinarily skilled in the subject matter or art exercising reasonable diligence can locate it.’” *Id.*

The issue of a reference’s public accessibility often arises in the context of references stored in libraries. In such cases, we generally inquire whether the reference was sufficiently indexed or cataloged. Here, we encounter a different question: whether the distribution of certain materials to groups of people at one or more meetings renders such materials printed publications under [pre-AIA § 102(b)]. We have stated that a printed publication “need not be easily searchable after publication if it was sufficiently disseminated at the time of its publication.” *Suffolk Techs., LLC v. AOL Inc.*, 752 F.3d 1358, 1365 (Fed. Cir. 2014) (concluding that an electronic newsgroup post was sufficiently disseminated where the newsgroup was populated by those of ordinary skill in the art and “dialogue with the intended audience was the entire purpose of the newsgroup postings,” even though the post was non-indexed and non-searchable). The parties here do not allege that the Video and Slides were stored somewhere for public access after the conferences. Thus, the question becomes whether such materials were sufficiently disseminated at the time of their distribution at the conferences. A survey of previous cases involving distribution of materials at meetings provides factors relevant to this case.

For example, in *Massachusetts Institute of Technology v. AB Fortia (MIT)*, a paper that was orally presented at a conference to a group of cell culturists interested in the subject matter was considered a “printed publication.” 774 F.2d 1104, 1109 (Fed. Cir. 1985). In that case, between 50 and 500 persons having ordinary skill in the art were told of the existence of the paper and informed of its contents by the oral presentation. We took note that the document itself was disseminated without restriction to at least six persons. Thus, whether the copies were freely distributed to interested members of the public was a key consideration in our analysis.



## NOVELTY

We highlighted a similar consideration concerning expectations of confidentiality as part of the public-accessibility inquiry in *Cordis Corp. v. Boston Scientific Corp.*, 561 F.3d 1319 (Fed. Cir. 2009). There, the issue pertained to whether a set of research papers distributed by a doctor to certain colleagues and two commercial entities rendered the documents printed publications. We concluded that such documents were not publicly accessible. As for the doctor's presentation of his work to his university and hospital colleagues, we noted that the record contained clear evidence that the academic norms gave rise to an expectation that disclosures would remain confidential. Likewise, we held that the doctor giving the research papers to two companies in an attempt to commercialize the technology did not make the documents accessible to the public. In so concluding, we emphasized the importance of an expectation of confidentiality between the doctor and each of the two commercial entities. The mere fact that there was no legal obligation of confidentiality was insufficient by itself to show that the doctor's expectation of confidentiality was unreasonable.

*In re Klopfenstein* is also instructive in its identification of the relevant factors. The reference in dispute in that case was a printed slide presentation that was displayed prominently for three days at a conference to a wide variety of participants. The reference was shown with no stated expectation that the information would not be copied or reproduced by those viewing it. But copies were never distributed to the public and never indexed. Under such a scenario, we identified the relevant factors to include: (1) "the length of time the display was exhibited," (2) "the expertise of the target audience" (to determine how easily those who viewed the material could retain the information), (3) "the existence (or lack thereof) of reasonable expectations that the material displayed would not be copied," and (4) "the simplicity or ease with which the material displayed could have been copied." After reviewing these factors, we determined that the reference was sufficiently publicly accessible to count as a "printed publication" for the purposes of [pre-AIA § 102(b)].

These decisions illustrate some common considerations about materials that are distributed at meetings or conferences. As relevant to this case, the size and nature of the meetings and whether they are open to people interested in the subject matter of the material disclosed are important considerations. Another factor is whether there is an expectation of confidentiality between the distributor and the recipients of the materials. Even if there is no formal, legal obligation of confidentiality, it still may be relevant to determine whether any policies or practices associated with a particular group meeting would give rise to an expectation that disclosures would remain confidential.

The record does not show that the Board fully considered all of the relevant factors. As a threshold matter, the Board did not address the potentially-critical difference between the SDSG meeting in Arizona and the programs in Colorado Springs and St.

Louis, which were not limited to members of the SDSG but instead were attended by at least 75 other surgeons, collectively. Also, Medtronic's expert, Dr. Lenke, testified that the materials were distributed without restrictions at the Colorado Springs and St. Louis programs. Although the Board found that disclosure to a small group of experts in the members-only SDSG meeting was insufficient to compel a finding that the Video and Slides were publicly available, its analysis was silent on the distribution that occurred in the two non-SDSG programs.

Further, even if the Board were correct in its assumption that Medtronic only gave the Video and Slides to the SDSG members, it did not address whether the disclosures would remain confidential. The Board found that SDSG members were experts voted into membership by an executive board based on their qualifications and research, but the relatively exclusive nature of the SDSG membership is only one factor in the public accessibility analysis. It may be relevant, for example, to consider the purpose of the meetings and to determine whether the SDSG members were expected to maintain the confidentiality of received materials or would be permitted to share or even publicize the insights gained and materials collected at the meetings.

Accordingly, whether dissemination of the Video and Slides to a set of supremely-skilled experts in a technical field precludes finding such materials to be printed publications warrants further development in the record. The expertise of the target audience can be a factor in determining public accessibility. *See In re Klopfenstein*, 380 F.3d at 1350–51 (“The expertise of the intended audience can help determine how easily those who viewed it could retain the displayed material.”). But this factor alone is not dispositive of the inquiry. Distributing materials to a group of experts, does not, without further basis, render those materials publicly accessible or inaccessible, simply by virtue of the relative expertise of the recipients. The nature of those meetings, as well as any restrictions on public disclosures, expectations of confidentiality, or, alternatively, expectations of sharing the information gained, can bear important weight in the overall inquiry.

For these reasons, we vacate the Board's finding that the Video and Slides are not printed publications and remand for further proceedings consistent with this opinion.

### Context & Application

1. In addition to the video and slides, Medtronic submitted that “(1) U.S. Patent Application No. 2005/0245928 (the '928 Application); and (2) a book chapter which appears in *MASTERS TECHNIQUES IN ORTHOPAEDIC SURGERY: THE SPINE* (2d ed.) (MTOS)” qualified as prior art. Which category of 102(a) does each fall into?

## NOVELTY

2. As information is increasingly distributed electronically, the PTO and the courts have had to evaluate more ephemeral and less tangible distribution modes as “printed publications.” In *Medtronic*, the court discussed numerous precedents to reason its way to its holding. One of those, *In re Klopfenstein*, involved a presentation about cereal preparation methods given at a meeting of the American Association of Cereal Chemists. In that case, the court catalogued prior cases:

*Cronyn* involved college students’ presentations of their undergraduate theses to a defense committee made up of four faculty members. Their theses were later catalogued in an index in the college’s main library. The index was made up of thousands of individual cards that contained only a student’s name and the title of his or her thesis. The index was searchable by student name and the actual theses themselves were neither included in the index nor made publicly accessible. We held that because the theses were only presented to a handful of faculty members and “had not been cataloged or indexed in a meaningful way,” they were not sufficiently publicly accessible for the purposes of 35 U.S.C. § 102(b).

In *Hall*, this court determined that a thesis filed and indexed in a university library did count as a “printed publication.” The *Hall* court arrived at its holding after taking into account that copies of the indexed thesis itself were made freely available to the general public by the university more than one year before the filing of the relevant patent application in that case. But the court in *Hall* did not rest its holding merely on the indexing of the thesis in question. Instead, it used indexing as a factor in determining “public accessibility.”

In *MIT*, a paper delivered orally to the First International Cell Culture Congress was considered a “printed publication.” In that case, as many as 500 persons having ordinary skill in the art heard the presentation, and at least six copies of the paper were distributed. The key to the court’s finding was that actual copies of the presentation were distributed. The court did not consider the issue of indexing. The *MIT* court determined the paper in question to be a “printed publication” but did not limit future determinations of the applicability of the “printed publication” bar to instances in which copies of a reference were actually offered for distribution.

Finally, the *Wyer* court determined that an Australian patent application kept on microfilm at the Australian Patent Office was “sufficiently accessible to the public and to persons skilled in the pertinent art to qualify as a ‘printed publication.’” The court so found even though it did not determine whether or not there was “actual viewing or dissemination” of the patent application. It was sufficient for the court’s purposes that the records of the application were kept so that they could be accessible to the public. According to the *Wyer* court, the entire purpose

of the “printed publication” bar was to “prevent withdrawal” of disclosures “already in the possession of the public” by the issuance of a patent.

*In re Klopfenstein*, 380 F.3d 1345, 1349 (Fed. Cir. 2004) (citing *In re Cronyn*, 890 F.2d 1158, 1161 (Fed. Cir. 1989); *In re Hall*, 781 F.2d 897, 898–99 (Fed. Cir. 1986); *Mass. Inst. of Tech. v. AB Fortia*, 774 F.2d 1104, 1108–10 (Fed. Cir. 1985); *In re Wyer*, 655 F.2d 221, 226 (C.C.P.A. 1981)). Does *Medtronic* appear to be consistent with these precedents? Should the changing nature of information-sharing and the technologies through which it is accomplished inform courts’ determinations of what is a printed publication? If you were university counsel advising professors about patents and presentations, how would you advise them?

3. *Medtronic* and the cases cited in the previous note are all based on the pre-AIA version of § 102. Nonetheless, the general consensus is that the use of mostly identical terminology for prior art categories indicates congressional intent for the doctrinal development surrounding these terms to remain good law.

4. Patents are generally published documents, and so it may seem strange that they comprise their own category. Usually, patents do count as printed publications. In fact, most countries publish applications 18 months post-filing, making those count as prior art as well. In limited circumstances, however, patents do not count as publications, such as when they are issued by a foreign country that does not make patents publicly accessible. For example, if a foreign country has a utility model patent system (a registration system that allows for lower protection and a lower obviousness standard), it might not make the patents publicly accessible such that they would be considered a printed publication. When this is the case, only its claims constitute prior art, not the entire disclosure of the document. *See, e.g., Reeves Bros. v. United States Laminating Corp.*, 282 F. Supp. 118 (E.D.N.Y. 1966) (holding that the structure of the utility model patent was sufficiently similar to utility patents to count as a patent under § 102, though the document was not published). Moreover, as noted above, patents and published applications are prior art as of their filing dates under § 102(a)(2).

## 2. Public Use

A claimed invention is not patentable if it was “in public use . . . before the effective filing date of the claimed invention.” 35 U.S.C. § 102(a)(1). So what is a “public use” for the purposes of patent law? The answer may surprise you.

*City of Elizabeth v. American Nicholson Pavement Co.*  
97 U.S. 126 (1877)

MR. JUSTICE BRADLEY delivered the opinion of the court.

This suit was brought by the American Nicholson Pavement Company against the city of Elizabeth, N. J., George W. Tubbs, and the New Jersey Wood-Paving Company, a corporation of New Jersey, upon a patent issued to Samuel Nicholson, dated Aug. 20, 1867, for a new and improved wooden pavement, being a second reissue of a patent issued to said Nicholson Aug. 8, 1854. . . .

. . .

The bill charges that the defendants infringed this patent by laying down wooden pavements in the city of Elizabeth, N.J., constructed in substantial conformity with the process patented, and prays an account of profits, and an injunction.

The defendants answered in due course . . . [and, among other things,] averred that the alleged invention of Nicholson was in public use, with his consent and allowance, for six years before he applied for a patent, on a certain avenue in Boston called the Mill-dam; and contended that said public use worked an abandonment of the pretended invention.

. . .

The next question to be considered is, whether Nicholson's invention was in public use or on sale, with his consent and allowance, for more than two years prior to his application for a patent, within the meaning of the sixth, seventh, and fifteenth sections of the act of 1836, as qualified by the seventh section of the act of 1839, which were the acts in force in 1854, when he obtained his patent. It is contended by the appellants that the pavement which Nicholson put down by way of experiment, on Mill-dam Avenue in Boston, in 1848, was publicly used for the space of six years before his application for a patent, and that this was a public use within the meaning of the law.

To determine this question, it is necessary to examine the circumstances under which this pavement was put down, and the object and purpose that Nicholson had in view. It is perfectly clear from the evidence that he did not intend to abandon his right to a patent. He had filed a caveat in August, 1847, and he constructed the pavement in question by way of experiment, for the purpose of testing its qualities. The road in which it was put down, though a public road, belonged to the Boston and Roxbury Mill Corporation, which received toll for its use; and Nicholson was a stockholder and treasurer of the corporation. The pavement in question was about seventy-five feet in length, and was laid adjoining to the toll-gate and in front of the toll-house. It was constructed by Nicholson at his own expense, and was placed by him where it was, in order to see the effect upon it of heavily

loaded wagons, and of varied and constant use; and also to ascertain its durability, and liability to decay. Joseph L. Lang, who was toll-collector for many years, commencing in 1849, familiar with the road before that time, and with this pavement from the time of its origin, testified as follows: "Mr. Nicholson was there almost daily, and when he came he would examine the pavement, would often walk over it, cane in hand, striking it with his cane, and making particular examination of its condition. He asked me very often how people liked it, and asked me a great many questions about it. I have heard him say a number of times that this was his first experiment with this pavement, and he thought that it was wearing very well. The circumstances that made this locality desirable for the purpose of obtaining a satisfactory test of the durability and value of the pavement were: that there would be a better chance to lay it there; he would have more room and a better chance than in the city; and, besides, it was a place where most everybody went over it, rich and poor. It was a great thoroughfare out of Boston. It was frequently travelled by teams having a load of five or six tons, and some larger. As these teams usually stopped at the toll-house, and started again, the stopping and starting would make as severe a trial to the pavement as it could be put to."

This evidence is corroborated by that of several other witnesses in the cause; the result of the whole being that Nicholson merely intended this piece of pavement as an experiment, to test its usefulness and durability. Was this a public use, within the meaning of the law?

An abandonment of an invention to the public may be evinced by the conduct of the inventor at any time, even within the two years named in the law. The effect of the law is, that no such consequence will necessarily follow from the invention being in public use or on sale, with the inventor's consent and allowance, at any time within two years before his application; but that, if the invention is in public use or on sale prior to that time, it will be conclusive evidence of abandonment, and the patent will be void.

But, in this case, it becomes important to inquire what is such a public use as will have the effect referred to. That the use of the pavement in question was public in one sense cannot be disputed. But can it be said that the invention was in public use? The use of an invention by the inventor himself, or of any other person under his direction, by way of experiment, and in order to bring the invention to perfection, has never been regarded as such a use. CURTIS, PATENTS, sect. 381; *Shaw v. Cooper*, 7 Pet. 292.

Now, the nature of a street pavement is such that it cannot be experimented upon satisfactorily except on a highway, which is always public.

When the subject of invention is a machine, it may be tested and tried in a building, either with or without closed doors. In either case, such use is not a public use, within the meaning of the statute, so long as the inventor is engaged, in good faith, in testing its

## NOVELTY

operation. He may see cause to alter it and improve it, or not. His experiments will reveal the fact whether any and what alterations may be necessary. If durability is one of the qualities to be attained, a long period, perhaps years, may be necessary to enable the inventor to discover whether his purpose is accomplished. And though, during all that period, he may not find that any changes are necessary, yet he may be justly said to be using his machine only by way of experiment; and no one would say that such a use, pursued with a bona fide intent of testing the qualities of the machine, would be a public use, within the meaning of the statute. So long as he does not voluntarily allow others to make it and use it, and so long as it is not on sale for general use, he keeps the invention under his own control, and does not lose his title to a patent.

It would not be necessary, in such a case, that the machine should be put up and used only in the inventor's own shop or premises. He may have it put up and used in the premises of another, and the use may inure to the benefit of the owner of the establishment. Still, if used under the surveillance of the inventor, and for the purpose of enabling him to test the machine, and ascertain whether it will answer the purpose intended, and make such alterations and improvements as experience demonstrates to be necessary, it will still be a mere experimental use, and not a public use, within the meaning of the statute.

Whilst the supposed machine is in such experimental use, the public may be incidentally deriving a benefit from it. If it be a grist-mill, or a carding-machine, customers from the surrounding country may enjoy the use of it by having their grain made into flour, or their wool into rolls, and still it will not be in public use, within the meaning of the law.

But if the inventor allows his machine to be used by other persons generally, either with or without compensation, or if it is, with his consent, put on sale for such use, then it will be in public use and on public sale, within the meaning of the law.

If, now, we apply the same principles to this case, the analogy will be seen at once. Nicholson wished to experiment on his pavement. He believed it to be a good thing, but he was not sure; and the only mode in which he could test it was to place a specimen of it in a public roadway. He did this at his own expense, and with the consent of the owners of the road. Durability was one of the qualities to be attained. He wanted to know whether his pavement would stand, and whether it would resist decay. Its character for durability could not be ascertained without its being subjected to use for a considerable time. He subjected it to such use, in good faith, for the simple purpose of ascertaining whether it was what he claimed it to be. Did he do any thing more than the inventor of the supposed machine might do, in testing his invention? The public had the incidental use of the pavement, it is true; but was the invention in public use, within the meaning of the statute? We think not. The proprietors of the road alone used the invention, and used it at

Nicholson's request, by way of experiment. The only way in which they could use it was by allowing the public to pass over the pavement.

Had the city of Boston, or other parties, used the invention, by laying down the pavement in other streets and places, with Nicholson's consent and allowance, then, indeed, the invention itself would have been in public use, within the meaning of the law; but this was not the case. Nicholson did not sell it, nor allow others to use it or sell it. He did not let it go beyond his control. He did nothing that indicated any intent to do so. He kept it under his own eyes, and never for a moment abandoned the intent to obtain a patent for it.

...

It is sometimes said that an inventor acquires an undue advantage over the public by delaying to take out a patent, inasmuch as he thereby preserves the monopoly to himself for a longer period than is allowed by the policy of the law; but this cannot be said with justice when the delay is occasioned by a bona fide effort to bring his invention to perfection, or to ascertain whether it will answer the purpose intended. His monopoly only continues for the allotted period, in any event; and it is the interest of the public, as well as himself, that the invention should be perfect and properly tested, before a patent is granted for it. Any attempt to use it for a profit, and not by way of experiment, for a longer period than two years before the application, would deprive the inventor of his right to a patent.

*Egbert v. Lippman*  
104 U.S. 333 (1881)

MR. JUSTICE WOODS delivered the opinion of the court.

This suit was brought for an alleged infringement of the complainant's reissued letters-patent, No. 5216, dated Jan. 7, 1873, for an improvement in corset-springs.

The original letters bear date July 17, 1866, and were issued to Samuel H. Barnes. The reissue was made to the complainant, under her then name, Frances Lee Barnes, executrix of the original patentee.

The specification for the reissue declares:—

“This invention consists in forming the springs of corsets of two or more metallic plates, placed one upon another, and so connected as to prevent them from sliding off each other laterally or edgewise, and at the same time admit of their playing or sliding upon each other, in the direction of their length or longitudinally, whereby



## NOVELTY

their flexibility and elasticity are greatly increased, while at the same time much strength is obtained.”

The second claim is as follows:—

“A pair of corset-springs, each member of the pair being composed of two or more metallic plates, placed one on another, and fastened together at their centres, and so connected at or near each end that they can move or play on each other in the direction of their length.”

The bill alleges that Barnes was the original and first inventor of the improvement covered by the reissued letters-patent, and that it had not, at the time of his application for the original letters, been for more than two years in public use or on sale, with his consent or allowance. . . .

We have . . . to consider whether the defense that the patented invention had, with the consent of the inventor, been publicly used for more than two years prior to his application for the original letters, is sustained by the testimony in the record.

The [statutes in effect at the relevant times] render letters-patent invalid if the invention which they cover was in public use, with the consent and allowance of the inventor, for more than two years prior to his application. . . .

. . .

The evidence on which the defendants rely to establish a prior public use of the invention consists mainly of the testimony of the complainant.

She testifies that Barnes invented the improvement covered by his patent between January and May, 1855; that between the dates named the witness and her friend Miss Cugier were complaining of the breaking of their corset-steels. Barnes, who was present, and was an intimate friend of the witness, said he thought he could make her a pair that would not break. At their next interview he presented her with a pair of corset-steels which he himself had made. The witness wore these steels a long time. In 1858 Barnes made and presented to her another pair, which she also wore a long time. When the corsets in which these steels were used wore out, the witness ripped them open and took out the steels and put them in new corsets. This was done several times.

It is admitted . . . that these steels embodied the invention afterwards patented by Barnes and covered by the reissued letters-patent on which this suit is brought.

Joseph H. Sturgis, another witness for complainant, testifies that in 1863 Barnes spoke to him about two inventions made by himself, one of which was a corset-steel, and that he went to the house of Barnes to see them. Before this time, and after the transactions testified to by the complainant, Barnes and she had intermarried. Barnes said his wife had

a pair of steels made according to his invention in the corsets which she was then wearing, and if she would take them off he would show them to witness. Mrs. Barnes went out, and returned with a pair of corsets and a pair of scissors, and ripped the corsets open and took out the steels. Barnes then explained to witness how they were made and used.

...

We observe, in the first place, that to constitute the public use of an invention it is not necessary that more than one of the patented articles should be publicly used. The use of a great number may tend to strengthen the proof, but one well-defined case of such use is just as effectual to annul the patent as many. For instance, if the inventor of a mower, a printing-press, or a railway-car makes and sells only one of the articles invented by him, and allows the vendee to use it for two years, without restriction or limitation, the use is just as public as if he had sold and allowed the use of a great number.

We remark, secondly, that, whether the use of an invention is public or private does not necessarily depend upon the number of persons to whom its use is known. If an inventor, having made his device, gives or sells it to another, to be used by the donee or vendee, without limitation or restriction, or injunction of secrecy, and it is so used, such use is public, even though the use and knowledge of the use may be confined to one person.

We say, thirdly, that some inventions are by their very character only capable of being used where they cannot be seen or observed by the public eye. An invention may consist of a lever or spring, hidden in the running gear of a watch, or of a ratchet, shaft, or cog-wheel covered from view in the recesses of a machine for spinning or weaving. Nevertheless, if its inventor sells a machine of which his invention forms a part, and allows it to be used without restriction of any kind, the use is a public one. So, on the other hand, a use necessarily open to public view, if made in good faith solely to test the qualities of the invention, and for the purpose of experiment, is not a public use within the meaning of the statute. *Elizabeth v. Pavement Company*, 97 U.S. 126; *Shaw v. Cooper*, 7 Pet. 292.

Tested by these principles, we think the evidence of the complainant herself shows that for more than two years before the application for the original letters there was, by the consent and allowance of Barnes, a public use of the invention, covered by them. He made and gave to her two pairs of corset-steels, constructed according to his device, one in 1855 and one in 1858. They were presented to her for use. He imposed no obligation of secrecy, nor any condition or restriction whatever. They were not presented for the purpose of experiment, nor to test their qualities. . . . The invention was at the time complete, and there is no evidence that it was afterwards changed or improved. The donee of the steels used them for years for the purpose and in the manner designed by the

inventor. They were not capable of any other use. She might have exhibited them to any person, or made other steels of the same kind, and used or sold them without violating any condition or restriction imposed on her by the inventor.

According to the testimony of the complainant, the invention was completed and put into use in 1855. The inventor slept on his rights for eleven years. Letters-patent were not applied for till March, 1866. In the mean time, the invention had found its way into general, and almost universal, use. A great part of the record is taken up with the testimony of the manufacturers and venders of corset-steels, showing that before he applied for letters the principle of his device was almost universally used in the manufacture of corset-steels. It is fair to presume that having learned from this general use that there was some value in his invention, he attempted to resume, by his application, what by his acts he had clearly dedicated to the public.

“An abandonment of an invention to the public may be evinced by the conduct of the inventor at any time, even within the two years named in the law. The effect of the law is that no such consequence will necessarily follow from the invention being in public use or on sale, with the inventor’s consent and allowance, at any time within the two years before his application; but that, if the invention is in public use or on sale prior to that time, it will be conclusive evidence of abandonment, and the patent will be void.” *Elizabeth v. Pavement Company*, supra.

We are of opinion that the defense of two years’ public use, by the consent and allowance of the inventor, before he made application for letters-patent, is satisfactorily established by the evidence.

MR. JUSTICE MILLER dissenting.

The sixth section of the act of July 4, 1836, c. 357, makes it a condition of the grant of a patent that the invention for which it was asked should not, at the time of the application for a patent, “have been in public use or on sale with the consent or allowance” of the inventor or discoverer. Section fifteen of the same act declares that it shall be a good defense to an action for infringement of the patent, that it had been in public use or on sale with the consent or allowance of the patentee before his application. This was afterwards modified by the seventh section of the act of March 3, 1839, c. 88, which declares that no patent shall be void on that ground unless the prior use has been for more than two years before the application.

This is the law under which the patent of the complainant is held void by the opinion just delivered. The previous part of the same section requires that the invention must be one “not known or used by others” before the discovery or invention made by the applicant. In this limitation, though in the same sentence as the other, the word “public” is not used, so that the use by others which would defeat the applicant, if without his

consent, need not be public; but where the use of his invention is by his consent or allowance, it must be public or it will not have that affect.

The reason of this is undoubtedly that, if without his consent others have used the machine, composition, or manufacture, it is strong proof that he was not the discoverer or first inventor. In that case he was not entitled to a patent. If the use was with his consent or allowance, the fact that such consent or allowance was first obtained is evidence that he was the inventor, and claimed to be such. In such case, he was not to lose his right to a patent, unless the use which he permitted was such as showed an intention of abandoning his invention to the public. It must, in the language of the act, be in public use or on sale. If on sale, of course the public who buy can use it, and if used in public with his consent, it may be copied by others. In either event there is an end of his exclusive right of use or sale.

The word public is, therefore, an important member of the sentence. A private use with consent, which could lead to no copy or reproduction of the machine, which taught the nature of the invention to no one but the party to whom such consent was given, which left the public at large as ignorant of this as it was before the author's discovery, was no abandonment to the public, and did not defeat his claim for a patent. If the little steep spring inserted in a single pair of corsets, and used by only one woman, covered by her outer-clothing, and in a position always withheld from public observation, is a public use of that piece of steel, I am at a loss to know the line between a private and a public use.

The opinion argues that the use was public, because, with the consent of the inventor to its use, no limitation was imposed in regard to its use in public. It may be well imagined that a prohibition to the party so permitted against exposing her use of the steel spring to public observation would have been supposed to be a piece of irony. An objection quite the opposite of this suggested by the opinion is, that the invention was incapable of a public use. That is to say, that while the statute says the right to the patent can only be defeated by a use which is public, it is equally fatal to the claim, when it is permitted to be used at all, that the article can never be used in public.

I cannot on such reasoning as this eliminate from the statute the word public, and disregard its obvious importance in connection with the remainder of the act, for the purpose of defeating a patent otherwise meritorious.

### Context & Application

1. It might seem like *Elizabeth* would have been a helpful precedent for Egbert. Do you think that *Elizabeth* shaped how Egbert's attorneys elicited (and made arguments based on) her testimony? Why did *Elizabeth* ultimately end up being unhelpful for Egbert?

2. Kara Swanson has argued that “it was not that Samuel ‘slept on his rights,’” but that Frances wielded those rights, publicly and successfully, which better explains the Supreme Court’s broad definition of ‘public’” in *Egbert*. Kara W. Swanson, *Getting A Grip on the Corset: Gender, Sexuality, and Patent Law*, 23 YALE J.L. & FEMINISM 57, 73 (2011).

Gender roles in Victorian America were understood by what is often referred to by historians, although not by Victorians themselves, as the “ideology of separate spheres.” This ideology . . . described a sex-segregated society in which men engaged in commerce, the business of earning a livelihood, in the public sphere, and then retreated to the domestic sphere, where their wives and daughters, angels of the home, used their feminine nature to provide a welcoming private life. The public sphere and its activities and relationships were masculine; the private sphere and its activities and relationships were feminine. This ideology did not reflect reality for most American men and women, but as an ideology, it was enormously influential in these decades in shaping how men and women enacted their gender roles.

*Id.* at 89–90. The corset itself helped to police the boundary between these spheres, “through its physical effects” (i.e., actually making women weaker) and through “cultural meanings” (such as defining the idealized feminine shape). *See id.* at 91. Swanson argues that while the decision in *Egbert* suggests that “the majority was motivated by a suspicion that Samuel had acted unfairly in delaying his application,” *id.* at 109, that view might be better understood “as reflecting the gender assumptions of the Court, at work even as the Justices surprisingly placed Frances in the public realm.” *Id.* at 110. According to Swanson:

The Court assumed that Samuel as a male inventor was commercially savvy and economically rational in his actions. There is no indication in the record, however, that Samuel felt that his invention had increased in commercial worth during the 1850s, or that he paid particular attention to developments in corset technology. Rather, he appears to have been an underemployed, dreamy tinkerer, with many unrelated ideas, and no personal or financial resources to realize any of them. It was Frances, as a consumer of corsets, who testified that she had owned multiple pairs during the decade in question, and she who was in a position to appreciate the value of Samuel’s invention. Her estimation may have motivated her marriage, after eight years’ intimacy, to a man she described as poor, sick, and depressed. It was after the marriage that Samuel decided to test the steels on a “very stout lady.” It may well have been at Frances’s initiative that he did so, and also at her urging that he finally “nerved himself” to patent the invention three years after their marriage. Less than two months after receiving the patent, Samuel was dead, leaving a written will despite his apparent lack of worldly goods, and Frances moved quickly to go into business and to maximize the value of his estate.

Frances showed every sign of being a savvy businesswoman both before and after her re-marriage to Wesley Egbert in 1870. Ironically, while there was no evidence that Frances moved to exploit Samuel's invention or to reveal it to the public in any way before he filed his application, after his death, she brought her corseted self firmly into the public sphere, engaging in all the activities which the Court suggested she might have earlier—exhibiting the steels, making others, and selling them. After eleven years of merely experiencing the private benefit of durable corset steels, by the time she testified as a litigant, she was using her commercial exploitation of Samuel's steels to support herself and her new husband. In 1881, Frances, as a businesswoman, was unquestionably engaged in the public use of Samuel's steels, while between 1855 and 1863, she had kept them, as far as the record reveals, as an undisclosed element of her personal wardrobe. The Supreme Court's opinion thus involved a temporal sleight of hand, shifting Frances and her corset *nunc pro tunc*, and also a transposition of Frances's ambition (a masculine trait with no place in the private feminine sphere of home and hearth) to the hapless Samuel.

. . . Frances was not unique as a female business owner and patentee in corset manufacture, but in the facts of *Egbert*, she becomes unique as a woman who made a transition from an intimate friend of the inventor, who wore his personal gift of a reinforced pair of corset steels, to a manufacturer of corset steels and enforcer of the Barnes patent. . . . Frances remains singular as a donee who became a patent owner and litigator. This transition moved Frances from a relationship in which male and female actions could be understood through the prevailing gender ideology of the time, into a role in which she acted in the public sphere directly, without the mediation of a man, and in unspoken defiance of the separate spheres ideology.

*Id.* at 110–11. Do you think this case would have come out differently if Samuel and Frances had been married at the time he started making corset-springs? Or if Wesley had been the one to lead the effort to commercialize the patent?

3. These cases mention a two-year statutory bar to patenting. In 1939, Congress changed this “grace period” from two years to one. Act of Aug. 5, 1939 ch. 450, § 1, 53 Stat. 1212. *See also* 2A CHISUM ON PATENTS § 6.02 (2020). While the AIA restructured § 102, public use remains invalidating and the doctrinal developments preceding these notes remain good law.

4. If you're ever in Pittsburgh, Pennsylvania, you can see “the only street in the country paved entirely in accordance with . . . Nicholson pavement.” Jenna Solomon, *Pittsburgh's Wood-Paved Roslyn Place*, PENNSYLVANIA HERITAGE, Winter 2020, at 40, 41.

*Moleculon Research Corp. v. CBS, Inc.*

793 F.2d 1261(Fed. Cir. 1986)

BALDWIN, Circuit Judge.

This is an appeal from the judgment of the United States District Court for the District of Delaware . . . holding claims 3-5 and 9 of Moleculon Research Corporation's U.S. Patent No. 3,655,201 ('201 patent) valid and infringed by certain of the well-known Rubik's Cube puzzles. We affirm in part, vacate in part, and remand.

*Background*

Moleculon, as assignee of the '201 patent which issued to Larry D. Nichols, sued CBS Inc., as successor to the Ideal Toy Corporation, alleging infringement of claims 3, 4, 5, 6, and 9 of the '201 patent.

A puzzle enthusiast since childhood, Nichols, in the summer of 1957, conceived of a three-dimensional puzzle capable of rotational movement. He envisioned an assembly of eight cubes attached in a  $2 \times 2 \times 2$  arrangement, with each of the six faces of the composite cube distinguished by a different color and the individual cubes being capable of rotation in sets of four around one of three mutually perpendicular axes.

During the period 1957-1962, while doing graduate work in organic chemistry, Nichols constructed several paper models of his puzzle, making cubes of heavy file-card type paper and affixing small magnets to the inside of the cubes. Although these models confirmed the feasibility of Nichols' conception, they lacked durability. A few close friends, including two roommates and a colleague in the chemistry department, had occasion to see one of these paper models in Nichols' room and Nichols explained its operation to at least one of them.

In 1962, Nichols accepted employment as a research scientist at Moleculon. In 1968, Nichols constructed a working wood block prototype of his puzzle which he usually kept at home but on occasion brought into his office. In January 1969, Dr. Obermayer, the president of Moleculon, entered Nichols' office and happened to see the model sitting on his desk. Obermayer expressed immediate interest in the puzzle and Nichols explained its workings. Obermayer asked whether Nichols intended to commercialize the puzzle. When Nichols said no, Obermayer suggested that Moleculon try to do so. In March 1969, Nichols assigned all his rights in the puzzle invention to Moleculon in return for a share of any proceeds of commercialization. On March 7, 1969, Moleculon sent Parker Brothers an actual model and a description of the cube puzzle. In the next three years, Moleculon contacted between fifty and sixty toy and game manufacturers, including Ideal. Ideal responded to the effect that it did not currently have an interest in marketing the puzzle. Moleculon itself did not succeed in marketing the Nichols cube.

## CHAPTER 6

On March 3, 1970, Nichols filed on behalf of Moleculon a patent application covering his invention. The '201 patent issued on April 11, 1972.

The subject matter of the '201 patent, in its preferred embodiment, is a cube puzzle composed of eight smaller cubelets that may be rotated in groups of four adjacent cubes, and a method by which the sets of cubes may be rotated, first to randomize, and then to restore a predetermined pattern on the six faces of the composite cube. . . .

### *Opinion*

CBS argues that the subject matter of the '201 patent was in "public use" and "on sale" by Nichols, prior to the March 3, 1969 critical date (i.e., one year prior to filing of the patent application), thus rendering the patent invalid under [pre-AIA] section 102(b).

### A

CBS labels as public use Nichols' displaying of the models to other persons (such as his colleagues at school) without any mention of secrecy. CBS ascribes only commercial purpose and intent to Obermeyer's use of the wood model and argues that a conclusion of barring public use under § 102(b) is compelled. We disagree.

This is what the district court had to say:

The essence of "public use" is the free and unrestricted giving over of an invention to a member of the public or the public in general. What I see here, by contrast, is the inventor's private use of his own invention for his own enjoyment. "Private use of one's own invention is permissible."

While it is true that Nichols explained his puzzle to a few close colleagues who inquired about it and allowed Obermayer to in fact use it, the personal relationships and other surrounding circumstances were such that Nichols at all times retained control over its use as well as over the distribution of information concerning it. He never used the puzzle or permitted it used in a place or at a time when he did not have a legitimate expectation of privacy and of confidentiality. In these respects, I consider the exposure to Obermayer in Nichols' office no different than the exposure of Nichols' close friends in his home . . . .

. . .

The district court distinguished *Egbert* because here Nichols had not given over the invention for free and unrestricted use by another person. Based on the personal relationships and surrounding circumstances, the court found that Nichols at all times retained control over the puzzle's use and the distribution of information concerning it. The court characterized Nichols' use as private and for his own enjoyment. We see neither legal error in the analysis nor clear error in the findings.



## NOVELTY

As for Obermayer's brief use of the puzzle, the court found that Nichols retained control even though he and Obermayer had not entered into any express confidentiality agreement. The court held, and we agree, that the presence or absence of such an agreement is not determinative of the public use issue. . . .

. . .

CBS had the burden at trial to prove public use with facts supported by clear and convincing evidence. We think the district court's characterization of the evidence of record is entirely apt and we see no ground for reversal. Moreover, we agree with the district court that its conclusion on public use is consistent with the policies underlying the bar.

CBS further argues in connection with public use that the district court erred when it found no evidence of commercially motivated activity by Nichols prior to the critical date. Although CBS attempts to paint a picture of commercialization from the discussions between Obermayer and Nichols, we see only the brush strokes of speculation. The record lacks hard evidence. Discussion between employer and employee does not by itself convert an employee's private pursuit into commercial enterprise with the employer. CBS also makes much of a February 6, 1969 phone call by Obermayer to Parker Brothers to see if the latter was interested in receiving a submission of a puzzle idea from an outside inventor. Nothing concerning the nature or workings of Nichols' puzzle was disclosed. Obermayer simply inquired whether and how an outsider could submit a puzzle for Parker Brothers' consideration. We agree with the district court that those facts do not show commercialization. Thus this case differs from other cases where commercial activity was said to violate the policies of section 102(b).

### B

CBS argues that the claimed invention was on sale within the meaning of 35 U.S.C. § 102(b) because Nichols orally agreed prior to the critical date (e.g., during a January 1969 conversation between Nichols and Obermayer) to assign "all his rights in the puzzle invention" to Moleculon. According to CBS, Nichols not only assigned the right to apply for a patent on the invention but also conveyed title in his single wooden model.

Although the formal written assignment occurred after the critical date, the district court held that even if there were an earlier oral agreement, an assignment or sale of the rights in the invention and potential patent rights is not a sale of "the invention" within the meaning of section 102(b). We agree. . . .

. . .

Accordingly, we sustain the district court's determination that the claims are not invalid under section 102(b). . . .

*Metallizing Eng'g Co. v. Kenyon Bearing & Auto Parts Co.*  
153 F.2d 516 (2d Cir. 1946)

HAND, Circuit Judge.

[John Meduna filed a patent application on August 6, 1942 for a process for conditioning metal surfaces to better bond with spray metal, useful for building up worn, metal parts of machines. The patent, issued on May 25, 1943, was assigned to Metallizing Engineering, which sued defendants for infringement. The district court held the patent not invalid and infringed and defendants appealed.]

The only question which we find necessary to decide is as to Meduna's public use of the patented process more than one year before August 6, 1942. The district judge made findings about this, which are supported by the testimony and which we accept. . . . The kernel of them is the following: "the inventor's main purpose in his use of the process prior to August 6, 1941, and especially in respect to all jobs for owners not known to him, was commercial, and an experimental purpose in connection with such use was subordinate only." Upon this finding he concluded as matter of law that, since the use before the critical date—August 6, 1941—was not primarily for the purposes of experiment, the use was not excused for that reason. Moreover, he also concluded that the use was not public but secret, and for that reason that its predominantly commercial character did prevent it from invalidating the patent. For the last he relied upon our decisions in *Peerless Roll Leaf Co. v. Griffin & Sons*, 29 F.2d 646, and *Gillman v. Stern*, 114 F.2d 28. We think that his analysis of *Peerless Roll Leaf Co. v. Griffin & Sons*, was altogether correct, and that he had no alternative but to follow that decision; on the other hand, we now think that we were then wrong and that the decision must be overruled for reasons we shall state. *Gillman v. Stern, supra*, was, however, rightly decided.

...

In the lower courts we may begin with the often cited decision in *Macbeth-Evans Glass Co. v. General Electric Co.*, 6 Cir., 246 F. 695, which concerned a process patent for making illuminating glass. The patentee had kept the process as secret as possible, but for ten years had sold the glass, although this did not, so far as appears, disclose the process. The court held the patent invalid for two reasons, as we understand them: the first was that the delay either indicated an intention to abandon, or was of itself a forfeiture, because of the inconsistency of a practical monopoly by means of secrecy and of a later legal monopoly by means of a patent. Judge Warrington seems to have been construing [the phrase "public use"] and to hold that the sales were such a use. In *Allinson Manufacturing Co. v. Ideal Filter Co.*, 8 Cir., 21 F.2d 22, the patent was for a machine for purifying gasoline: the machine was kept secret, but the gasoline had been sold for a period of six years before

the application was filed. As in *Macbeth-Evans*, the court apparently invalidated the patent on two grounds: one was that the inventor had abandoned the right to a patent, or had forfeited it by his long delay. We are disposed however to read the latter part as holding that the sale of gasoline was a “prior use” of the machine, notwithstanding its concealment. . . .

Coming now to our own decisions . . . the first was *Grasselli Chemical Co. v. National Aniline & Chemical Co.*, 2 Cir., 26 F.2d 305, in which the patent was for a process which had been kept secret, but the product had been sold upon the market for more than two years. We held that, although the process could not have been discovered from the product, the sales constituted a “prior use,” relying upon *Egbert v. Lippmann*, and *Hall v. Macneale*. There was nothing in this inconsistent with what we are now holding. But in *Peerless*, where the patent was for a machine, which had been kept secret, but whose output had been freely sold on the market, we sustained the patent on the ground that “the sale of the product was irrelevant, since no knowledge could possibly be acquired of the machine in that way. In this respect the machine differs from a process . . . or from any other invention necessarily contained in a product.” So far as we can now find, there is nothing to support this distinction in the authorities, and we shall try to show that we misapprehended the theory on which the prior use by an inventor forfeits his right to a patent. . . . In *Gillman*, it was not the inventor, but a third person who used the machine secretly and sold the product openly, and there was therefore no question either of abandonment or forfeiture by the inventor. The only issue was whether a prior use which did not disclose the invention to the art was within the statute; and it is well settled that it is not. As in the case of any other anticipation, the issue of invention must then be determined by how much the inventor has contributed any new information to the art.

From the foregoing it appears that in *Peerless*, we confused two separate doctrines: (1) The effect upon his right to a patent of the inventor’s competitive exploitation of his machine or of his process; (2) the contribution which a prior use by another person makes to the art. Both do indeed come within the phrase, “prior use”; but the first is a defence for quite different reasons from the second. It had its origin—at least in this country—in *Pennock v. Dialogue*, 2 Pet. 1, 7 L.Ed. 327, [holding] that it is a condition upon an inventor’s right to a patent that he shall not exploit his discovery competitively after it is ready for patenting; he must content himself with either secrecy, or legal monopoly. It is true that for the limited period of two years he was allowed to do so, possibly in order to give him time to prepare an application; and even that has been recently cut down by half. But if he goes beyond that period of probation, he forfeits his right regardless of how little the public may have learned about the invention; just as he can forfeit it by too long concealment, even without exploiting the invention at all. . . .

It is indeed true that an inventor may continue for more than a year to practice his invention for his private purposes of his own enjoyment and later patent it. But that is, properly considered, not an exception to the doctrine, for he is not then making use of his secret to gain a competitive advantage over others; he does not thereby extend the period of his monopoly. Besides, as we have seen, even that privilege has its limits, for he may conceal it so long that he will lose his right to a patent even though he does not use it at all. With that question we have not however any concern here.

Judgment reversed; complaint dismissed.

### Context & Application

1. What distinguishes *Moleculon* from *Metallizing Engineering*? Neither inventor intended for their uses to be public. Is the result in *Metallizing Engineering* consistent with the stated purpose of the novelty requirement: to stop things that are in the public domain from being withdrawn and protected by a patent? And if not, what is the court's justification for invalidating a patent based on secret, non-informing uses?

### 3. On Sale

The next category of prior art is the "on sale" bar. The statute provides that a claimed invention is not patentable if it was "on sale . . . before the effective filing date of the claimed invention." 35 U.S.C. § 102(a)(1). Just as the "public use" category of prior art forced courts to ascertain whether particular uses are sufficiently "public" to fall within the scope of the statute, the "on sale" category has raised some thorny questions about what exactly it means for something to be sold. In 1998, the Supreme Court addressed some of the questions that arise from the several steps—advertisement, offer, development, construction—associated with selling products and processes.

*Pfaff v. Wells Electronics, Inc.*,  
525 U.S. 55 (1998)

JUSTICE STEVENS delivered the opinion of the Court.

Section 102(b) of the Patent Act of 1952 provides that no person is entitled to patent an "invention" that has been "on sale" more than one year before filing a patent application. We granted certiorari to determine whether the commercial marketing of a newly invented product may mark the beginning of the 1-year period even though the invention has not yet been reduced to practice.

## NOVELTY

### I

On April 19, 1982, petitioner, Wayne Pfaff, filed an application for a patent on a computer chip socket. Therefore, April 19, 1981, constitutes the critical date for purposes of the on-sale bar of 35 U.S.C. § 102(b); if the 1-year period began to run before that date, Pfaff lost his right to patent his invention.

Pfaff commenced work on the socket in November 1980, when representatives of Texas Instruments asked him to develop a new device for mounting and removing semiconductor chip carriers. In response to this request, he prepared detailed engineering drawings that described the design, the dimensions, and the materials to be used in making the socket. Pfaff sent those drawings to a manufacturer in February or March 1981.

Prior to March 17, 1981, Pfaff showed a sketch of his concept to representatives of Texas Instruments. On April 8, 1981, they provided Pfaff with a written confirmation of a previously placed oral purchase order for 30,100 of his new sockets for a total price of \$91,155. In accord with his normal practice, Pfaff did not make and test a prototype of the new device before offering to sell it in commercial quantities.

The manufacturer took several months to develop the customized tooling necessary to produce the device, and Pfaff did not fill the order until July 1981. The evidence therefore indicates that Pfaff first reduced his invention to practice in the summer of 1981. The socket achieved substantial commercial success before Patent No. 4,491,377 (the '377 patent) issued to Pfaff on January 1, 1985.

After the patent issued, petitioner brought an infringement action against respondent, Wells Electronics, Inc., the manufacturer of a competing socket. Wells prevailed on the basis of a finding of no infringement. When respondent began to market a modified device, petitioner brought this suit, alleging that the modifications infringed six of the claims in the '377 patent.

...

The Court of Appeals reversed, finding all six claims invalid. Four of the claims (1, 6, 7, and 10) described the socket that Pfaff had sold to Texas Instruments prior to April 8, 1981. Because that device had been offered for sale on a commercial basis more than one year before the patent application was filed on April 19, 1982, the court concluded that those claims were invalid under § 102(b). That conclusion rested on the court's view that as long as the invention was "substantially complete at the time of sale," the 1-year period began to run, even though the invention had not yet been reduced to practice. The other two claims (11 and 19) described a feature that had not been included in Pfaff's initial design, but the Court of Appeals concluded as a matter of law that the additional feature

was not itself patentable because it was an obvious addition to the prior art. Given the court's § 102(b) holding, the prior art included Pfaff's first four claims.

Because other courts have held or assumed that an invention cannot be "on sale" within the meaning of § 102(b) unless and until it has been reduced to practice and because the text of § 102(b) makes no reference to "substantial completion" of an invention, we granted certiorari.

## II

The primary meaning of the word "invention" in the Patent Act unquestionably refers to the inventor's conception rather than to a physical embodiment of that idea. The statute does not contain any express requirement that an invention must be reduced to practice before it can be patented. Neither the statutory definition of the term in § 100 nor the basic conditions for obtaining a patent set forth in § 101 make any mention of "reduction to practice." The statute's only specific reference to that term is found in § 102(g), which sets forth the standard for resolving priority contests between two competing claimants to a patent. [Ed. note: Section 102(g) governed disputes regarding who was the first to invent the subject matter of a claimed invention; because the AIA replaced the first-to-invent regime with a first-to-file regime, there is no longer an equivalent provision in Section 102.] That subsection provides:

In determining priority of invention there shall be considered not only the respective dates of conception and reduction to practice of the invention, but also the reasonable diligence of one who was first to conceive and last to reduce to practice, from a time prior to conception by the other.

Thus, assuming diligence on the part of the applicant, it is normally the first inventor to conceive, rather than the first to reduce to practice, who establishes the right to the patent.

It is well settled that an invention may be patented before it is reduced to practice. In 1888, this Court upheld a patent issued to Alexander Graham Bell even though he had filed his application before constructing a working telephone. Chief Justice Waite's reasoning in that case merits quoting at length:

It is quite true that when Bell applied for his patent he had never actually transmitted telegraphically spoken words so that they could be distinctly heard and understood at the receiving end of his line, but in his specification he did describe accurately and with admirable clearness his process, that is to say, the exact electrical condition that must be created to accomplish his purpose, and he also described, with sufficient precision to enable one of ordinary skill in such matters to make it, a form of apparatus which, if used in the way pointed out, would produce the required effect, receive the words, and carry them to and

## NOVELTY

deliver them at the appointed place. The particular instrument which he had, and which he used in his experiments, did not, under the circumstances in which it was tried, reproduce the words spoken, so that they could be clearly understood, but the proof is abundant and of the most convincing character, that other instruments, carefully constructed and made exactly in accordance with the specification, without any additions whatever, have operated and will operate successfully. A good mechanic of proper skill in matters of the kind can take the patent and, by following the specification strictly, can, without more, construct an apparatus which, when used in the way pointed out, will do all that it is claimed the method or process will do . . . .

“The law does not require that a discoverer or inventor, in order to get a patent for a process, must have succeeded in bringing his art to the highest degree of perfection. It is enough if he describes his method with sufficient clearness and precision to enable those skilled in the matter to understand what the process is, and if he points out some practicable way of putting it into operation.” *The Telephone Cases*, 126 U.S. 1 (1888).

When we apply the reasoning of *The Telephone Cases* to the facts of the case before us today, it is evident that Pfaff could have obtained a patent on his novel socket when he accepted the purchase order from Texas Instruments for 30,100 units. At that time he provided the manufacturer with a description and drawings that had “sufficient clearness and precision to enable those skilled in the matter” to produce the device. The parties agree that the sockets manufactured to fill that order embody Pfaff’s conception as set forth in claims 1, 6, 7, and 10 of the ’377 patent. We can find no basis in the text of § 102(b) or in the facts of this case for concluding that Pfaff’s invention was not “on sale” within the meaning of the statute until after it had been reduced to practice.

### III

Pfaff nevertheless argues that longstanding precedent, buttressed by the strong interest in providing inventors with a clear standard identifying the onset of the 1-year period, justifies a special interpretation of the word “invention” as used in § 102(b). [T]his nontextual argument should be rejected.

As we have often explained, most recently in *Bonito Boats, Inc. v. Thunder Craft Boats, Inc.*, 489 U.S. 141, 151 (1989), the patent system represents a carefully crafted bargain that encourages both the creation and the public disclosure of new and useful advances in technology, in return for an exclusive monopoly for a limited period of time. The balance between the interest in motivating innovation and enlightenment by rewarding invention with patent protection on the one hand, and the interest in avoiding monopolies that unnecessarily stifle competition on the other, has been a feature of the federal patent laws since their inception. As this Court explained in 1871:

## CHAPTER 6

Letters patent are not to be regarded as monopolies . . . but as public franchises granted to the inventors of new and useful improvements for the purpose of securing to them, as such inventors, for the limited term therein mentioned, the exclusive right and liberty to make and use and vend to others to be used their own inventions, as tending to promote the progress of science and the useful arts, and as matter of compensation to the inventors for their labor, toil, and expense in making the inventions, and reducing the same to practice for the public benefit, as contemplated by the Constitution and sanctioned by the laws of Congress.

*Seymour v. Osborne*, 78 U.S. 516 , 11 Wall. 516, 533-534, 20 L. Ed. 33.

Consistent with these ends, § 102 of the Patent Act serves as a limiting provision, both excluding ideas that are in the public domain from patent protection and confining the duration of the monopoly to the statutory term.

We originally held that an inventor loses his right to a patent if he puts his invention into public use before filing a patent application. “His voluntary act or acquiescence in the public sale and use is an abandonment of his right” *Pennock v. Dialogue*, 2 Pet. 1, 24 (1829) (Story, J.). A similar reluctance to allow an inventor to remove existing knowledge from public use undergirds the on-sale bar.

Nevertheless, an inventor who seeks to perfect his discovery may conduct extensive testing without losing his right to obtain a patent for his invention -- even if such testing occurs in the public eye. The law has long recognized the distinction between inventions put to experimental use and products sold commercially. In 1878, we explained why patentability may turn on an inventor’s use of his product.

It is sometimes said that an inventor acquires an undue advantage over the public by delaying to take out a patent, inasmuch as he thereby preserves the monopoly to himself for a longer period than is allowed by the policy of the law; but this cannot be said with justice when the delay is occasioned by a bona fide effort to bring his invention to perfection, or to ascertain whether it will answer the purpose intended. His monopoly only continues for the allotted period, in any event; and it is the interest of the public, as well as himself, that the invention should be perfect and properly tested, before a patent is granted for it. *Any attempt to use it for a profit, and not by way of experiment, for a longer period than two years before the application, would deprive the inventor of his right to a patent.*

*Elizabeth v. Pavement Co.*, 97 U.S. 126.

The patent laws therefore seek both to protect the public’s right to retain knowledge already in the public domain and the inventor’s right to control whether and when he may patent his invention. The Patent Act of 1836 was the first statute that expressly



## NOVELTY

included an on-sale bar to the issuance of a patent. Like the earlier holding in *Pennock*, that provision precluded patentability if the invention had been placed on sale at any time before the patent application was filed. In 1839, Congress ameliorated that requirement by enacting a 2-year grace period in which the inventor could file an application.

In *Andrews v. Hovey*, 123 U.S. 267, 274 (1887), we noted that the purpose of that amendment was “to fix a period of limitation which should be certain”; it required the inventor to make sure that a patent application was filed “within two years from the completion of his invention.” In 1939, Congress reduced the grace period from two years to one year.

Petitioner correctly argues that these provisions identify an interest in providing inventors with a definite standard for determining when a patent application must be filed. A rule that makes the timeliness of an application depend on the date when an invention is “substantially complete” seriously undermines the interest in certainty. More-over, such a rule finds no support in the text of the statute. Thus, petitioner’s argument calls into question the standard applied by the Court of Appeals, but it does not persuade us that it is necessary to engraft a reduction to practice element into the meaning of the term “invention” as used in § 102(b).

The word “invention” must refer to a concept that is complete, rather than merely one that is “substantially complete.” It is true that reduction to practice ordinarily provides the best evidence that an invention is complete. But just because reduction to practice is sufficient evidence of completion, it does not follow that proof of reduction to practice is necessary in every case. Indeed, both the facts of the *Telephone Cases* and the facts of this case demonstrate that one can prove that an invention is complete and ready for patenting before it has actually been reduced to practice.

We conclude, therefore, that the on-sale bar applies when two conditions are satisfied before the critical date. First, the product must be the subject of a commercial offer for sale. An inventor can both understand and control the timing of the first commercial marketing of his invention. The experimental use doctrine, for example, has not generated concerns about indefiniteness, and we perceive no reason why unmanageable uncertainty should attend a rule that measures the application of the on-sale bar of § 102(b) against the date when an invention that is ready for patenting is first marketed commercially. In this case the acceptance of the purchase order prior to April 8, 1981, makes it clear that such an offer had been made, and there is no question that the sale was commercial rather than experimental in character.

Second, the invention must be ready for patenting. That condition may be satisfied in at least two ways: by proof of reduction to practice before the critical date; or by proof that prior to the critical date the inventor had prepared drawings or other descriptions of the

invention that were sufficiently specific to enable a person skilled in the art to practice the invention. In this case the second condition of the on-sale bar is satisfied because the drawings Pfaff sent to the manufacturer before the critical date fully disclosed the invention.

The evidence in this case thus fulfills the two essential conditions of the on-sale bar. As succinctly stated by Learned Hand:

It is a condition upon an inventor's right to a patent that he shall not exploit his discovery competitively after it is ready for patenting; he must content himself with either secrecy, or legal monopoly.

*Metallizing Eng'g Co. v. Kenyon Bearing & Auto Parts Co.*, 153 F.2d 516, 520 (2d. Cir. 1946).

The judgment of the Court of Appeals finds support not only in the text of the statute but also in the basic policies underlying the statutory scheme, including § 102(b). When Pfaff accepted the purchase order for his new sockets prior to April 8, 1981, his invention was ready for patenting. The fact that the manufacturer was able to produce the socket using his detailed drawings and specifications demonstrates this fact. Furthermore, those sockets contained all the elements of the invention claimed in the '377 patent. Therefore, Pfaff's '377 patent is invalid because the invention had been on sale for more than one year in this country before he filed his patent application. Accordingly, the judgment of the Court of Appeals is affirmed.

*Helsinn Healthcare S.A. v. Teva Pharmaceuticals USA, Inc.*

855 F.3d 1356 (Fed. Cir. 2017)

DYK, Circuit Judge.

Helsinn Healthcare is the owner of the four patents-in-suit directed to intravenous formulations of palonosetron for reducing, or reducing the likelihood of, chemotherapy-induced nausea and vomiting ("CINV").

Helsinn brought suit against Teva Pharmaceuticals alleging that the filing of Teva's Abbreviated New Drug Application ("ANDA") constituted an infringement of various claims of those patents. Teva defended, inter alia, on the ground that the asserted claims were invalid under the on-sale bar provision of 35 U.S.C. § 102. The district court found that the patents in suit were not invalid. With respect to three of the patents, which are governed by the pre-Leahy-Smith America In-vents Act ("pre-AIA") version of § 102, the district court concluded that there was a commercial offer for sale before the critical date, but that the invention was not ready for patenting before the critical date. With respect to the fourth patent, which is governed by the AIA version of § 102, the district court

## NOVELTY

concluded that there was no commercial offer for sale because the AIA changed the relevant standard, and that, in any event, the invention was not ready for patenting before the critical date.

We reverse. The asserted claims of the patents-in-suit were subject to an invalidating contract for sale prior to the critical date of January 30, 2002, and the AIA did not change the statutory meaning of “on sale” in the circumstances involved here. The asserted claims were also ready for patenting prior to the critical date.

### *Background*

Helsinn owns four patents, U.S. Patent 7,947,724; 7,947,725; 7,960,424; and 8,598,219, directed to reducing the likelihood of CINV. CINV is a serious side effect of chemotherapy treatment.

The use of palonosetron to treat CINV was not new. . . . The patents in suit purport to disclose novel intravenous formulations using unexpectedly low concentrations of palonosetron that were not taught by the prior art. All four of the patents in suit claim priority to a provisional patent application filed on January 30, 2003. The critical date for the on-sale bar is one year earlier, January 30, 2002. The significance of the critical date is that a sale of the invention before that date can be invalidating.

. . .

The claims of the patents-in-suit to some extent all express the same concepts in different terms. . . . It is undisputed that each asserted claim covers the 0.25 mg dose of palonosetron. In order to simplify the relevant discussion, we refer to the patents as covering the 0.25 mg dose.

In 1998, Helsinn acquired a license under the '333 patent from Roche Palo Alto LLC to palonosetron and all intellectual property resulting from ongoing palonosetron research. Roche and its predecessor, Syntex (USA) Inc., had already conducted Phase I and Phase II clinical trials. A Phase II trial—Study 2330—found that the 0.25 mg dose “was effective in suppressing chemotherapy-induced emesis for 24 hours.” Helsinn then submitted safety and efficacy protocols for Phase III clinical trials to FDA in early 2000, proposing to study two dosages—0.25 mg and 0.75 mg. By early 2001 the Phase III trials were ongoing but not yet completed.

On April 6, 2001, almost two years before applying for a patent, Helsinn and MGI Pharma, Inc., an oncology-focused pharmaceutical company that markets and distributes in the United States, entered into two agreements: (1) a License Agreement and (2) a Supply and Purchase Agreement. . . .

Under the terms of the License Agreement, MGI agreed to pay \$11 million in initial payments to Helsinn, plus additional future royalties on distribution of “products” in the

United States. The parties agree that the “products” covered by the License Agreement were 0.25 mg and 0.75 mg doses of palonosetron.

Under the Supply and Purchase Agreement, MGI agreed to purchase exclusively from Helsinn, and Helsinn agreed to supply MGI’s requirements of the 0.25 mg and 0.75 mg palonosetron products, or whichever of the two dosages were approved for sale by FDA. The agreement required MGI to submit purchase forecasts to Helsinn and to place firm orders at least 90 days before delivery. It also specified that such orders would be “subject to written acceptance and confirmation by [Helsinn] before becoming binding.” But, in the event that Helsinn were unable to meet MGI’s firm orders and to the extent they fell within the previously forecasted amount, Helsinn would then be obligated to designate a third party manufacturer to supply MGI with the product. The agreement specified price (29% of the gross sales price by MGI with a minimum of \$28.50 per vial), method of payment (wire transfer within 30 days of receipt of an invoice), and method of delivery (DDU—which means delivery duty unpaid).

The License Agreement made reference to the ongoing clinical trials and stated that in the event that the results were unfavorable and FDA did not approve the sale of either dosage of the product, Helsinn could terminate the agreement. If the License Agreement were terminated, the Supply and Purchase Agreement would “terminate automatically.”

All of the above information about the transaction was publicly disclosed with two exceptions. The two features of the agreements that were not publicly disclosed were the price terms and the specific dosage formulations covered by the agreements—that is the 0.25 and 0.75 mg doses.

Helsinn admitted at oral argument that the agreement was binding as of its effective date, April 6, 2001, and that it would cover either or both of the 0.25 and 0.75 mg doses, subject to FDA approval. Helsinn also agreed that, if the Phase III trials were successful and the products were approved by FDA, then the agreement obligated MGI to purchase and Helsinn to supply the approved doses. But if FDA did not approve either dose, then the agreement likewise would terminate automatically with the License Agreement. As Helsinn stated [at oral argument], in such a scenario “both parties could accept that fact and walk away.”

After the signing of the agreements, and still before the critical date, Helsinn prepared [a] preliminary statistical analysis of the earliest Phase III trial on January 7, 2002. The data showed that 81% of patients who received the 0.25 mg dose of palonosetron experienced relief from CINV for 24 hours. After the critical date of January 30, 2002, Helsinn submitted its preliminary Phase III data to FDA in early February. In September 2002, after the successful completion of all Phase III trials, Helsinn filed its New Drug Application for the 0.25 mg dose, but did not seek FDA approval of the 0.75 mg dose. On

## NOVELTY

January 30, 2003, Helsinn filed a provisional patent application covering the 0.25 mg dose (and also the 0.75 mg dose). FDA issued approval for the 0.25 dose on July 2003. [Helsinn then applied for and received four patents, all of which cover the 0.25 mg dose, are listed in FDA's "Orange Book," and claim priority to the January 30, 2003 date of the provisional application.]

In 2011, Teva filed an ANDA seeking FDA approval to market a generic 0.25 mg palonosetron product. Teva's ANDA filing included a Paragraph IV certification that the claims of the patents-in-suit were invalid and/or not infringed. Helsinn then brought suit

.....

### *Discussion*

#### I

We first address whether the invention of the '724, '725, and '424 patents was subject to a sale or offer for sale prior to the critical date. We recently had occasion to address the pre-AIA on-sale bar *en banc* in *Medicines Co. v. Hospira, Inc.*, 827 F.3d 1363 (Fed. Cir. 2016). There we established a framework for determining whether there is an offer for sale. We explained that the question must be "analyzed under the law of contracts as generally understood" and "must focus on those activities that would be understood to be commercial sales and offers for sale 'in the commercial community.'" While acknowledging that it is not of "talismanic significance" to our inquiry, "[a]s a general proposition, we will look to the Uniform Commercial Code ('UCC') to define whether a communication or series of communications rises to the level of a commercial offer for sale." A sale occurs when there is a "contract between parties to give and to pass rights of property for consideration which the buyer pays or promises to pay the seller for the thing bought or sold."

In *Medicines* we also pointed to other factors that are important to this analysis, but noted that, like the UCC itself, none is determinative individually. We noted that the absence of the passage of title, the confidential nature of a transaction, and the absence of commercial marketing of the invention all counsel against applying the on-sale bar. We deemed these factors important because they helped shed light on whether a transaction would be understood "in the commercial community" to constitute a commercial offer for sale. But those additional factors are not at issue in this case. . . .

We agree with the district court that there was a sale for purposes of pre-AIA § 102(b) prior to the critical date because there was a sale of the invention under the law of contracts as generally understood.

Helsinn admits that the Supply and Purchase Agreement was binding as of its effective date, April 6, 2001, and that, if FDA approved the 0.25 mg dose and/or the 0.75

mg dose of palonosetron, the agreement obligated Helsinn to sell and MGI to purchase those products. The Supply and Purchase Agreement bears all the hallmarks of a commercial contract for sale. It obligated MGI to purchase exclusively from Helsinn and obligated Helsinn to supply MGI's requirements of the 0.25 and 0.75 mg doses if approved by FDA.

The agreement here included other specific terms, such as price, method of payment, and method of delivery. Even though MGI's firm orders pursuant to the agreement were ostensibly "subject to written acceptance and confirmation by [Helsinn] before becoming binding," Helsinn was nonetheless obligated to meet or designate a third party manufacturer to meet MGI's firm orders. The public 8-K filing described the Supply and Purchase Agreement as obligating Helsinn to supply MGI's "requirements of finished product." . . . [T]he fact that an agreement covered one party's requirements as opposed to a specified quantity does not prevent application of the on-sale bar.

. . . Helsinn argues that the Supply and Purchase Agreement is not invalidating because at the critical date it was uncertain whether FDA would approve the 0.25 mg dose, and FDA approval was a condition precedent to the sale.

There can be no real dispute that an agreement contracting for the sale of the claimed invention contingent on regulatory approval is still a commercial sale as the commercial community would understand that term. The UCC expressly provides that a "purported present sale of future goods operates as a contract to sell." UCC § 2-105(2) (defining "future goods" as "goods which are not both existing and identified"). This is true irrespective of whether those future goods have yet to receive necessary regulatory approval. A contract for sale that includes a condition precedent is a valid and enforceable contract. Indeed, conditions precedent such as regulatory approval are a basic feature of contract law.

It has been implicit in our prior opinions that the absence of FDA or other regulatory approval before the critical date does not prevent a sale or offer for sale from triggering the on-sale bar. For instance, in *Enzo*, we applied the on-sale bar even though the contract for sale covered the buyer's reasonable requirements for "perform[ing] all preclinical and clinical studies," by definition before FDA approval, because the "claimed invention, the polynucleotide probe, is a tangible item or product that can be sold or offered for sale." . . .

. . .

It is clear that the Supply and Purchase Agreement constituted a commercial sale or offer for sale for purposes of § 102(b) as to the asserted claims of the '724, '725, and '424 patents.

## NOVELTY

### II

We next address whether the AIA changed the meaning of the on-sale bar under 35 U.S.C. § 102 so that there was no qualifying sale as to the '219 patent. . . .

Before the AIA, § 102(b) barred the patentability of an invention that was “patented or described in a printed publication in this or a foreign country or in public use or on sale in this country, more than one year prior to the date of the application for patent.” 35 U.S.C. § 102(b). Under that earlier provision, we concluded that, although confidentiality weighs against application of the on-sale bar, that fact alone is not determinative. For instance, in *In re Caveney*, a British company offered to sell the claimed invention to an American company that would be its exclusive seller in the United States before the critical date. The court rejected the argument that a sale or offer for sale did not trigger the on-sale bar when it had been “kept secret from the trade,” concluding that “sales or offers by one person of a claimed invention bar another party from obtaining a patent if the sale or offer to sell is made over a year before the latter’s filing date.”

By enacting the AIA, Congress amended § 102 to bar the patentability of an “invention [that] was patented, described in a printed publication, or in public use, on sale, or otherwise available to the public before the effective filing date of the claimed invention.” 35 U.S.C. § 102(a)(1).

Teva and various amici assert that by reenacting the existing statutory term, “on sale,” Congress did not change the meaning of the on-sale bar or disturb settled law. Helsinn, the government, and other amici argue that the AIA changed the law by adding the “otherwise available to the public” phrase. They argue that the on-sale bar now does not encompass secret sales and requires that a sale make the invention available to the public in order to trigger application of the on-sale bar. Apart from the additional statutory language, this argument primarily relies on floor statements made by individual members of Congress. While recognizing that such floor statements are typically not reliable as indicators of congressional intent, they argue that here we should look to the floor statements to determine the meaning of the provision. These floor statements include material such as the following:

Subsection 102(a) was drafted in part to do away with precedent under current law that *private offers for sale* or private uses or secret processes practiced in the United States that result in a product or service that is then made public may be deemed patent-defeating prior art. That will no longer be the case.

157 Cong. Rec. 3415 (2011) (remarks of Sen. Leahy).

The current on-sale bar imposes penalties not demanded by any legitimate public interest. There is no reason to fear “commercialization” that merely consists of a

*secret sale or offer for sale* but that does not operate to disclose the invention to the public. The present bill's new section 102(a) precludes extreme results such as these.

157 Cong. Rec. 3424 (2011) (remarks of Sen. Kyl).

...

The floor statements do not identify any sale cases that would be overturned by the amendments. Even if the floor statements were intended to overrule... *secret or confidential sale cases*..., that would have no effect here since those cases were concerned entirely with whether the existence of a sale or offer was public. Here, the existence of the sale—i.e., the Supply and Purchase Agreement between Helsinn and MGI—was publicly announced in MGI's 8-K filing with the SEC. The 8-K filing also included a copy of the contract for sale as an attachment, albeit partially redacted. Detailed information about palonosetron, its benefits and uses in treating CINV were also disclosed. The statements disclosed the chemical structure of palonosetron and specified that the covered products were “pharmaceutical preparations for human use in [intravenous] dosage form, containing [palonosetron] as an active ingredient.” And, as described above, the agreements disclosed all the pertinent details of the transaction other than the price and dosage levels.

Helsinn argues that the AIA did more than overrule the “secret sale” cases, and relies on the “otherwise available to the public” language in the statute and the floor statements. Helsinn argues that those statements suggest that the on-sale bar does not apply unless the sale “discloses the invention to the public” before the critical date. 157 Cong. Rec. 3424 (2011). It urges that since the 0.25 mg dose was not disclosed, the invention was not disclosed and the on-sale bar does not apply. The suggestion is that Congress required that the details of the claimed invention be publicly disclosed before the on-sale bar is triggered.

Requiring such disclosure as a condition of the on-sale bar would work a foundational change in the theory of the statutory on-sale bar. Indeed, the seminal Supreme Court decision in *Pennock* addressed exactly such a situation—the public sale of an item but the withholding from “the public the secrets of [the] invention.” *Pennock v. Dialogue*, 27 U.S. 1, 19 (1829). Failing to find such a sale invalidating... “would materially retard the progress of science and the useful arts, and give a premium to those who should be least prompt to communicate their discoveries.”

So too under our cases, an invention is made available to the public when there is a commercial offer or contract to sell a product embodying the invention and that sale is made public. Our cases explicitly rejected a requirement that the details of the invention be disclosed in the terms of sale.



## NOVELTY

A primary rationale of the on-sale bar is that publicly offering a product for sale that embodies the claimed invention places it in the public domain, regardless of when or whether actual delivery occurs. The patented product need not be on hand or even delivered prior to the critical date to trigger the on-sale bar. And, as previously noted, we have never required that a sale be consummated or an offer accepted for the invention to be in the public domain and the on-sale bar to apply, nor have we distinguished sales from mere offers for sale. We have also not required that members of the public be aware that the product sold actually embodies the claimed invention. For instance, in *Abbott Laboratories v. Geneva Pharmaceuticals, Inc.*, 182 F.3d 1315 (Fed. Cir. 1999), at the time of the sale, neither party to the transaction knew whether the product sold embodied the claimed invention and had no easy way to determine what the product was.

Thus, our prior cases have applied the on-sale bar even when there is no delivery, when delivery is set after the critical date, or, even when, upon delivery, members of the public could not ascertain the claimed invention. There is no indication in the floor statements that these members intended to overrule these cases. In stating that the invention must be available to the public they evidently meant that the public sale itself would put the patented product in the hands of the public. Senator Kyl himself seems to have agreed with this proposition, stating explicitly that “once a product is sold on the market, any invention that is inherent to the product becomes publicly available prior art and cannot be patented.” 157 Cong. Rec. 3423 (2011). There are no floor statements suggesting that the sale or offer documents must themselves publicly disclose the details of the claimed invention before the critical date. If Congress intended to work such a sweeping change to our on-sale bar jurisprudence and “wished to repeal these prior cases legislatively, it would do so by clear language.”

We conclude that, after the AIA, if the existence of the sale is public, the details of the invention need not be publicly disclosed in the terms of sale. For the reasons already stated, the Supply and Purchase Agreement between Helsinn and MGI constituted a sale of the claimed invention—the 0.25 mg dose—before the critical date, and therefore both the pre-AIA and AIA on-sale bars apply. We do not find that distribution agreements will always be invalidating under § 102. We simply find that this particular Supply and Purchase Agreement is.

...

We hold that the asserted claims . . . are invalid under the on-sale bar.

## Context &amp; Application

1. In another portion of the opinion, the *Helsinn* court stated:

At oral argument for the first time, *Helsinn* contended that applying the on-sale bar would be unfair because it would distinguish between vertically-integrated manufacturers that have in-house distribution capacity and smaller entities like *Helsinn* that must contract for distribution services from a third party. *Helsinn* asserts that *Medicines* stands for the proposition that we should not allow commercial activities to be invalidating if those same activities could be performed in-house without triggering the on-sale bar. Such a broad principle would largely eviscerate the on-sale bar provision except as to sales to end users; that was not the holding of *Medicines*. There we concluded that “stockpiling,” including purchases from a supplier, “does not trigger the on-sale bar.” We also expressed concern over a policy of “penalizing a company for relying, by choice or by necessity, on the confidential services of a contract manufacturer.” But the concern that *Medicines* focused on is not applicable here. *Helsinn* did not contract for MGI’s confidential marketing or distribution services as *Medicines* contracted for Ben Venue’s confidential manufacturing services. Instead, the Supply and Purchase Agreement between *Helsinn* and MGI unambiguously contemplated the sale by *Helsinn* of MGI’s requirements of the claimed invention.

The argument *Helsinn* is making here is about treating disaggregated entities engaged in different parts of innovation similarly to in-house innovation in a large company. In *Innovation and the Firm: A New Synthesis*, Peter Lee explains how some see a large role for “patents in promoting technology transactions between separate entities, thus facilitating vertical disintegration.” 70 STAN. L. REV. 1431, 1439-40 (2018). Lee goes on to explain that this vertical disintegration is not seen as frequently as one might expect; in contrast, one often sees vertical integration in innovation-heavy markets. He posits that one reason is that valuable information and resources, such as the tacit knowledge a company develops surrounding how to practice a patent and the scientists involved in development, add value beyond that contained in the patent document. *Id.* at 1455-87.

## C. Exceptions under § 102(b)

The effective filing date of a patent is not always the date against which prior art is measured. Under the AIA, prior art includes everything before the effective filing date, but some of that prior art will be excluded and not count for novelty purposes, if it meets certain requirements. This section will walk through a number of scenarios to

## NOVELTY

demonstrate when a disclosure will be considered prior art under the AIA and when it will be excluded.

Section 102(b) lists the disclosures that are excluded from the scope of the prior art:

(1) Disclosures made 1 year or less before the effective filing date of the claimed invention.—A disclosure made 1 year or less before the effective filing date of a claimed invention shall not be prior art to the claimed invention under subsection (a)(1) if—

(A) the disclosure was made by the inventor or joint inventor or by another who obtained the subject matter disclosed directly or indirectly from the inventor or a joint inventor; or

(B) the subject matter disclosed had, before such disclosure, been publicly disclosed by the inventor or a joint inventor or another who obtained the subject matter disclosed directly or indirectly from the inventor or a joint inventor.

(2) Disclosures appearing in applications and patents.—A disclosure shall not be prior art to a claimed invention under subsection (a)(2) if—

(A) the subject matter disclosed was obtained directly or indirectly from the inventor or a joint inventor;

(B) the subject matter disclosed had, before such subject matter was effectively filed under subsection (a)(2), been publicly disclosed by the inventor or a joint inventor or another who obtained the subject matter disclosed directly or indirectly from the inventor or a joint inventor; or

(C) the subject matter disclosed and the claimed invention, not later than the effective filing date of the claimed invention, were owned by the same person or subject to an obligation of assignment to the same person.

Let us break these down a bit. Section 102(b)(1)(A) says that if the inventor is the originator of the disclosure, and it is made in the year prior to the effective filing date, then it will not count as prior art. The timeline below represents this exclusion:

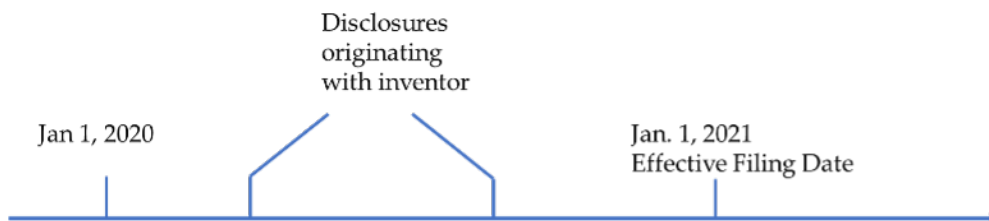

## CHAPTER 6

Section 102(b)(1)(A) provides that publications and acts by the inventor in the year leading up to filing will not count as invalidating prior art. This means that disclosures under section 102(a)(1) (i.e., when the invention is described in a patent, printed publication, in public use, on sale, or otherwise available to the public) originating with the inventor (i.e., the disclosure is by the inventor or joint inventor or by another who obtained the subject matter disclosed directly or indirectly from the inventor or a joint inventor) are excepted from the prior art. Skipping ahead to 102(b)(1)(C), disclosures that are commonly owned by the owner of the inventor before the effective filing date of a patent are also excepted from the prior art.

Section 102(b)(1)(B) addresses which disclosures made by third parties can be excepted from prior art. In the figure below, acts by the inventor/applicant are above the timeline. Acts by third parties are below it. To illustrate:

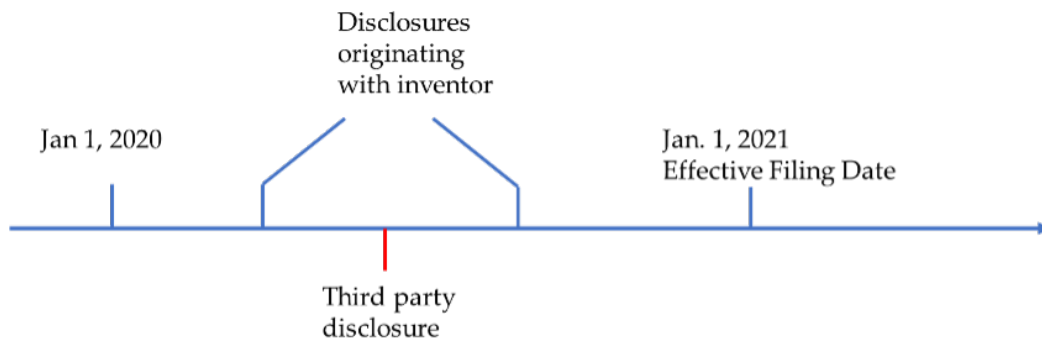

As shown above, there has been a third-party disclosure before the effective filing date. However, one of the inventor disclosures predates the third-party disclosure, therefore excepting it from the prior art. Thus, the disclosure shown below the line would be prior art if the inventor was not able to point to an earlier disclosure. And, of course, that earlier, inventor disclosure must still be within one year, or else it will count as prior art. The figure also depicts one inventor disclosure after the third-party disclosure; this disclosure would not result in the exclusion of the third-party disclosure from the scope of the prior art.

The set of exceptions in section 102(b)(2) relate to the disclosures in § 102(a)(2), namely published applications and issued patents. Remember that under § 102(a)(2) patents and published applications are prior art as of their effective filing dates. (They also count as printed publications as of their publication dates.)

Section 102(b)(2)(A) provides that any patents filed that describe the invention and originate with the inventor will not count as prior art against the invention. This could

include applications for related technologies, for example, that an inventor or company might file within months of each other.



Section 102(b)(2)(B) is the reason that the AIA is not a true first-to-file system, but instead may better be described as a first-to-disclose-and-file system. This is because an inventor's disclosure, such as a publication, for example, can knock a competitor's filed patent out of the prior art. This section provides that 102(a)(2) disclosures (patent applications that are later published or issued) are not prior art if the subject matter was previously "publicly disclosed by the inventor or a joint inventor or another who obtained the subject matter disclosed directly or indirectly from the inventor or a joint inventor." As illustrated below:



The third party filed *before* our inventor in the illustration above, and yet their filing will not count as invalidating prior art. That is because our inventor disclosed the invention before the third party. Does this mean that both are entitled to patents? No. Look at the situation from the third party's perspective, and you will see that the inventor's disclosure will count as § 102(a)(1) prior art against the third party's application. You may want to keep these timelines in mind when we return to the pre-AIA grace period in Section E, below.

#### D. Prior Art: Standards for Anticipation

Sections A and B demonstrated how courts determine whether certain materials or acts fit within the prior art categories of § 102(a). But that is not the end of the inquiry. Now we turn to the substance of prior art references, and the question of anticipation. The basic explanation of anticipation is as follows:

## CHAPTER 6

Section 102 embodies the concept of novelty—if a device or process has been previously invented (and disclosed to the public), then it is not new, and therefore the claimed invention is “anticipated” by the prior invention.

*Net MoneyIN, Inc. v. VeriSign, Inc.*, 545 F.3d 1359, 1369 (Fed. Cir. 2008). A prior art reference anticipates an invention if it (1) includes every element of a claimed invention (2) such that a person of skill in the art would understand from the reference how to make or use the invention. The Federal Circuit has explained the “all elements rule” this way:

Anticipation under 35 U.S.C. § 102 requires the presence in a single prior art disclosure of each and every element of a claimed invention. . . . That which would literally infringe if later in time anticipates if earlier than the date of invention.

*Lewmar Marine, Inc. v. Barient, Inc.*, 827 F.2d 744 (Fed. Cir. 1987). The second requirement, that a person of skill in the art would understand how to make or use the invention, is described as follows:

Because the hallmark of anticipation is prior invention, the prior art reference . . . must not only disclose all elements of the claim within the four corners of the document, but must also disclose those elements “arranged as in the claim.”

*Net MoneyIN*, 545 at 1369. Contrast this with the § 112 enablement requirement for patentability. It requires that a person of skill in the art be able to make *or* use the invention based on the disclosure, whereas section 112 requires that a person of skill in the art be able to make *and* use the invention based on its disclosure. Why might there be a lower standard to invalidate a patent based on prior art references than the standard for disclosure of an invention? The next cases demonstrate how courts apply the all elements rule and how they treat prior art that inherently discloses an invention.

### *Marrin v. Griffin* 599 F.3d 1290 (Fed. Cir. 2010)

DYK, Judge:

Appellants Jeffrey and Claudia Griffin (“the Griffins”) appeal from a judgment of the . . . district court grant[ing] summary judgment, finding the Griffins’ United States Patent No. 5,154,448 invalid under 35 U.S.C. § 102(b) as anticipated.

On appeal, the Griffins’ primary contention is that the trial court improperly failed to treat the “for permitting” language in the preamble as a claim limitation. We affirm.

## NOVELTY

### *Background*

In July of 1990, Jeffrey and Claudia Griffin conceived of the idea of using a scratch-off label to mark beverage containers and cups so that attendees of a gathering or party could keep track of their beverage cups. The Griffins filed a patent application in April 1991, and the '448 patent, entitled "Scratch-Off Marking Label," issued on October 13, 1992. Claim 1 of the patent, which is representative of the four disputed claims, reads as follows:

1. A scratch-off label for permitting a user to write thereon without the use of a marking implement, comprising:

a permanent base having a colored near side which is normally visible to the user and having a far side; and

a coating of scratch-off non-transparent material having a color which contrasts with the color of the near side of the permanent base, which coating is applied directly onto the near side of the permanent base with sufficient thickness so as to obscure the color of the permanent base, and which when scratched off reveals the color of the near side of the permanent base.

...

Michael Marrin formed a company, Upardi, Inc., to manufacture the labels, and containers with the labels . . . . On June 5, 2002, the Griffins entered into a license agreement with Upardi. The relationship between Michael Marrin and the Griffins broke down swiftly . . . . On April 11, 2006, the Griffins notified Michael Marrin that the license was terminated. In January 2007, Michael Marrin and Etch-It, Inc., a company Michael Marrin had created to market and sell scratch-off labels, filed an action for declaratory relief against the Griffins . . . seeking a determination, *inter alia*, that the Griffins '448 patent was invalid.

[The suit was consolidated with a state court claim of patent infringement brought by the Griffins against the Marrins and subsequently removed. The district court ruled on summary judgment that the '448 patent was invalid as anticipated.]

### *Discussion*

The Griffins' main argument on appeal is that the preamble's "for permitting" language should have been construed as a limitation on the scope of the claims and that the asserted prior art therefore does not anticipate. The Griffins acknowledge that the prior art disclosed scratch-off devices. However, the Griffins contend that the prior art did not disclose the ability of a user of a scratch-off device to write without the use of a marking implement, which was disclosed in the preamble to the claims of the '448 patent. The district court ruled that the "for permitting" language in the preamble was not a claim limitation based on its findings that (1) the preamble language added in the amendment

only added a statement of a purpose or an intended use for the invention, and (2) the patentee did not demonstrate clear reliance on the preamble during prosecution to distinguish the claimed invention from the prior art. We agree.

The preamble language indicates that the intended use of the scratch-off labels was “for permitting a user to write thereon without the use of a marking implement.” But use descriptions such as this are rarely treated as claim limitations. . . . “Preamble language that merely states the purpose or intended use of an invention is generally not treated as limiting the scope of the claim.” For apparatus claims, such as those in the ’448 patent, generally patentability “depends on the claimed structure, not on the use or purpose of that structure.” Here, the preamble language only added an intended use, namely, that the scratch-off layer may be used for writing. . . .

...

The Griffins also now argue that the asserted prior art fails to anticipate additional limitations from the body of the claims—namely, that the patented device includes a scratch-off coating that contrasts with the color of the device's permanent base. The law of anticipation is clear: “A prior art reference anticipates a patent claim if the reference discloses, either expressly or inherently, all of the limitations of the claim.” We agree with the district court that all of the limitations present in the claims of the ’448 patent were present in the prior art references. In particular, the Malinovitz patent taught scratch-off technologies for parking cards. The side-by-side comparison below of the prior art Malinovitz patent and the Griffins patent is sufficient to demonstrate that the Griffins patent does not include any limitations that were not in the Malinovitz patent.

Griffins Patent	Malinovitz (parking card) Patent
“a permanent base”	Teaches a “base card” that the removable coating is applied to. The base card’s surface is not removed when the coating is scratched off.
“a coating of scratch off non-transparent material”	The scratch off coating must be non-transparent since the coating “covers” dates which are only revealed when removed.
“having a color which contrasts with the color of the near side of the permanent base”	“The friable removable coating is of a different color, usually silver, than the underlying color of the card....”



## NOVELTY

Thus, we reject the Griffins' argument that the asserted prior art fails to disclose additional limitations present in the body of the claims of the Griffins patent.

### *In re Cruciferous Sprout Litigation* 301 F.3d 1343 (Fed. Cir. 2002)

PROST, Judge:

Brassica Protection Products LLC and Johns Hopkins University (collectively "Brassica") appeal from the decision . . . granting summary judgment that U.S. Patent Nos. 5,725,895; 5,968,567; and 5,968,505 are invalid as anticipated by the prior art. We affirm the district court's ruling.

#### *Background*

The three patents-in-suit relate to growing and eating sprouts to reduce the level of carcinogens in animals, thereby reducing the risk of developing cancer. Specifically, the patents describe methods of preparing food products that contain high levels of substances that induce Phase 2 enzymes. These enzymes are part of the human body's mechanism for detoxifying potential carcinogens. Thus, they have a chemoprotective effect against cancer. Foods that are rich in glucosinolates, such as certain cruciferous sprouts, have high Phase 2 enzyme-inducing potential. The inventors of the patents-in-suit recognized that the Phase 2 enzyme-inducing agents (or their glucosinolate precursors) are far more concentrated in certain sprouts (such as broccoli and cauliflower but not cabbage, cress, mustard or radish) that are harvested before the two-leaf stage than in corresponding adult plants. However, glucosinolate levels in cruciferous plants can be highly variable. According to the inventors, it is therefore desirable to select the seeds of those cruciferous plants which, when germinated and harvested before the two-leaf stage, produce sprouts that contain high levels of the desired enzyme-inducing potential.

The '895 patent was filed on September 15, 1995, and claims, *inter alia*, "A method of preparing a food product rich in glucosinolates, comprising germinating cruciferous seeds, with the exception of cabbage, cress, mustard and radish seeds, and harvesting sprouts prior to the 2-leaf stage, to form a food product comprising a plurality of sprouts." The '567 patent is a continuation of the '895 application and it claims a "method of preparing a human food product" from sprouts. The '505 patent is a divisional of the '895 application and it claims a "method of increasing the chemoprotective amount of Phase 2 enzymes in a mammal," as well as a "method of reducing the level of carcinogens in a mammal," by creating a "food product" from sprouts and then "administering said food product" to a mammal.

## CHAPTER 6

The three patents-in-suit are owned by Johns Hopkins University and exclusively licensed to Brassica Protection Products LLC. Johns Hopkins and Brassica sued Sunrise Farms [and others in various district courts and the cases were consolidated] . . . for pretrial proceedings.

### *Discussion*

Anticipation is a question of fact, and is determined by first construing the claims and then comparing the properly construed claims to the prior art . . . .

#### I

Brassica contends that the district court erroneously construed the claims by failing to treat the preamble of claim 1 of the '895 patent as a limitation of the claims. . . .

No litmus test defines when a preamble limits claim scope. Whether to treat a preamble as a limitation is a determination “resolved only on review of the entirety of the patent to gain an understanding of what the inventors actually invented and intended to encompass by the claim.” In general, a preamble limits the claimed invention if it recites essential structure or steps, or if it is “necessary to give life, meaning, and vitality” to the claim. Clear reliance on the preamble during prosecution to distinguish the claimed invention from the prior art may indicate that the preamble is a claim limitation because the preamble is used to define the claimed invention.

In this case, both the specification and prosecution history indicate that the phrase “rich in glucosinolates” helps to define the claimed invention and is, therefore, a limitation of claim 1 of the '895 patent. The specification, for example, states that “this invention relates to the production and consumption of foods which are rich in cancer chemoprotective compounds.” A stated object of the invention is “to provide food products and food additives that are rich in cancer chemoprotective compounds.” The specification therefore indicates that the inventors believed their invention to be making food products that are rich in chemoprotective compounds, [i.e.,] food products “rich in glucosinolates.” In addition, during reexamination of the '895 patent the patentee argued as follows:

Claim 1 of the patent, for example, is directed to “a method of preparing a food product rich in glucosinolates, and harvesting sprouts prior to the 2-leaf stage, to form a food product comprising a plurality of sprouts.” Although “rich in glucosinolates” is recited in the preamble of the claim, the pertinent case law holds that the preamble is given weight if it breathes life and meaning into the claim. Accordingly, the cited prior art does not anticipate the claims because it does not explicitly teach a method of preparing a food product comprising cruciferous

## NOVELTY

sprouts that are rich in glucosinolates or contain high levels of Phase 2 inducer activity.

This language shows a clear reliance by the patentee on the preamble to persuade the Patent Office that the claimed invention is not anticipated by the prior art. As such, the preamble is a limitation of the claims.

## II

In order to prove that a claim is anticipated under 35 U.S.C. § 102(b), defendants must present clear and convincing evidence that a single prior art reference discloses, either expressly or inherently, each limitation of the claim.

Brassica argues that the prior art does not expressly or inherently disclose the claim limitations of “preparing a food product rich in glucosinolates” or “identifying seeds which produce cruciferous sprouts . . . containing high Phase 2 enzyme-inducing potential.” According to Brassica, the prior art merely discusses growing and eating sprouts without mention of any glucosinolates or Phase 2 enzyme-inducing potential, and without specifying that particular sprouts having these beneficial characteristics should be assembled into a “food product.” Moreover, Brassica argues, the prior art does not inherently disclose these limitations because “at most, one following the prior art would have a possibility or probability of producing a food product high in Phase 2 enzyme-inducing potential” and the “fact that one following the prior art might have selected seeds meeting the limitations of the claims is not sufficient to establish inherent anticipation.”

It is well settled that a prior art reference may anticipate when the claim limitations not expressly found in that reference are nonetheless inherent in it. “Under the principles of inherency, if the prior art necessarily functions in accordance with, or includes, the claimed limitations, it anticipates.” *MEHL/Biophile Int’l Corp. v. Milgraum*, 192 F.3d 1362, 1365 (Fed. Cir. 1999) (finding anticipation of a method of hair depilation by an article teaching a method of skin treatment but recognizing the disruption of hair follicles). “Inherency is not necessarily coterminous with the knowledge of those of ordinary skill in the art. Artisans of ordinary skill may not recognize the inherent characteristics or functioning of the prior art.” *MEHL/Biophile*, 192 F.3d at 1365.

Brassica does not claim to have invented a new kind of sprout, or a new way of growing or harvesting sprouts. Rather, Brassica recognized that some sprouts are rich in glucosinolates and high in Phase 2 enzyme-inducing activity while other sprouts are not. But the glucosinolate content and Phase 2 enzyme-inducing potential of sprouts necessarily have existed as long as sprouts themselves, which is certainly more than one year before the date of application at issue here. *See, e.g.*, KAREN CROSS WHYTE, *THE COMPLETE SPROUTING COOKBOOK* 4 (1973) (noting that in “2939 B.C., the Emperor of China

recorded the use of health giving sprouts”). Stated differently, a sprout’s glucosinolate content and Phase 2 enzyme-inducing potential are inherent characteristics of the sprout. It matters not that those of ordinary skill heretofore may not have recognized these inherent characteristics of the sprouts.

*Titanium Metals Corp. v. Banner* is particularly instructive in this regard. In that case, the claim at issue recited:

A titanium base alloy consisting essentially by weight of about 0.6% to 0.9% nickel, 0.2% to 0.4% molybdenum, up to 0.2% maximum iron, balance titanium, said alloy being characterized by good corrosion resistance in hot brine environments.

The prior art disclosed a titanium base alloy having the recited components of the claim, but the prior art did not disclose that such an alloy was “characterized by good corrosion resistance in hot brine environments.” We nevertheless held that the claim was anticipated by the prior art, because “it is immaterial, on the issue of their novelty, what inherent properties the alloys have or whether these applicants discovered certain inherent properties.” *Titanium Metals* explained the rationale behind this common-sense conclusion:

The basic provision of Title 35 applicable here is § 101, providing in relevant part: “Whoever invents or discovers any new composition of matter, or any new improvement thereof, may obtain a patent therefor, subject to the conditions and requirements of this title.”

Counsel never came to grips with the real issues: (1) what do the claims cover and (2) is what they cover new? Under the laws Congress wrote, they must be considered. Congress has not seen fit to permit the patenting of an old alloy, known to others through a printed publication, by one who has discovered its corrosion resistance or other useful properties, or has found out to what extent one can modify the composition of the alloy without losing such properties.

Brassica has done nothing more than recognize properties inherent in certain prior art sprouts, just like the corrosion resistance properties inherent to the prior art alloy in *Titanium Metals*. While Brassica may have recognized something quite interesting about those sprouts, it simply has not invented anything new.

...

In summary, the prior art inherently contains the claim limitations that Brassica relies upon to distinguish its claims from the prior art. While Brassica may have recognized something about sprouts that was not known before, Brassica’s claims do not describe a new method.

## NOVELTY

### *Conclusion*

For the foregoing reasons, we affirm the district court's summary judgment that the claims at issue are anticipated by the prior art. The prior art indisputably includes growing, harvesting and eating particular sprouts which Brassica has recognized as being rich in glucosinolates and high in Phase 2 enzyme-inducing potential. But the glucosinolate content and Phase 2 enzyme-inducing potential of these sprouts are inherent properties of the sprouts put there by nature, not by Brassica. Brassica simply has not claimed anything that is new and its claims are therefore invalid.

### E. Comparing Novelty Pre- and Post-AIA

You have now read a number of cases that were decided under the pre-AIA novelty standards, so you have seen that much of the doctrine from before the AIA is still considered controlling. However, the structure of the earlier act was different, and because the patent system awarded priority to the first inventor—as opposed to the first filer—there were complicated factual determinations for the PTO and courts to make. In this section, we will start by looking at the pre-AIA version of § 102 and then we will compare it to the AIA.

Here is the pre-AIA version of § 102:

A person shall be entitled to a patent unless —

(a) the invention was known or used by others in this country, or patented or described in a printed publication in this or a foreign country, before the invention thereof by the applicant for patent, or

(b) the invention was patented or described in a printed publication in this or a foreign country or in public use or on sale in this country, more than one year prior to the date of the application for patent in the United States . . .

These provisions are fairly similar to those under AIA § 102(a). There are two notable differences. First, pre-AIA § 102 limited the geographic scope of the “known or used by others” and “in public use or on sale” categories to the United States; the AIA, on the other hand, accords a worldwide scope to the public use and sale categories.

Second, the pre-AIA § 102(a) refers to acts that occur “before the invention” by the applicant. This section is keyed towards acts by third parties that happen before the invention date—namely, disclosures that demonstrate the applicant was not the first to invent. In contrast, pre-AIA § 102(b) keys all activities to the critical date—one year prior to the filing date. This section is referred to as a statutory bar, and grants the “grace period” referred to in the cases we read, above. It means that disclosures in the year prior

to filing—whether originating with the inventor *or* made by a third party—will not count against the novelty of the invention. Under pre-AIA § 102(b), there is no need for the inventor to show that they have disclosed before a third-party disclosure. *All* activity within the grace period is excepted. The reason for this is that, while the AIA uses prior disclosure to prove priority, before the AIA, priority as between multiple applicants went to the first to have invented.

The next two provisions are also statutory bars, and also relate to acts by the inventor that can lead to invalidation, if:

(c) he has abandoned the invention,

(d) the invention was first patented or caused to be patented, or was the subject of an inventor's certificate, by the applicant or his legal representatives or assigns in a foreign country prior to the date of the application for patent in this country on an application for patent or inventor's certificate filed more than twelve months before the filing of the application in the United States,

These provisions are fairly straightforward, pertaining to abandonment and foreign filings more than one year prior to U.S. filing. We include the remainder of the statute, below.

(e) the invention was described in — (1) an application for patent, published under section 122(b), by another filed in the United States before the invention by the applicant for patent or (2) a patent granted on an application for patent by another filed in the United States before the invention by the applicant for patent, except that an international application filed under the treaty defined in section 351(a) shall have the effects for the purposes of this subsection of an application filed in the United States only if the international application designated the United States and was published under Article 21(2) of such treaty in the English language; or

(f) he did not himself invent the subject matter sought to be patented, or

(g) (1) during the course of an interference conducted under section 135 or section 291, another inventor involved therein establishes, to the extent permitted in section 104, that before such person's invention thereof the invention was made by such other inventor and not abandoned, suppressed, or concealed, or (2) before such person's invention thereof, the invention was made in this country by another inventor who had not abandoned, suppressed, or concealed it. In determining priority of invention under this subsection, there shall be considered not only the respective dates of conception and reduction to practice of the invention, but also the reasonable diligence of one who was first to conceive and last to reduce to practice, from a time prior to conception by the other.

## NOVELTY

Section 102(g) describes the proceedings for interferences, which was at the heart of the first to invent system. These proceedings, at the USPTO, involved dual—or more—claims to a patent, in which inventors would produce evidence of the date on which each claimed to have conceived of the invention. Whoever was able to prove the earliest date, and that from the time before their competitor conceived of the invention, they worked with reasonable diligence towards reducing the invention to practice, would prevail, gaining entitlement to a patent.

The pre-AIA novelty, statutory bar, and priority provisions are important for more than merely historical reasons. There are still patents very much in force that were filed under the pre-AIA provisions. However, with each year that passes, more of these patents expire, making it less likely that current law students will come across them in practice.





## 7. NONOBVIOUSNESS

To be patentable, an invention must not only be new, it must be new *enough*. This general principle—that a patentable invention must be more than merely novel—has been a part of U.S. patent law for a long time, though the name and precise contours of this requirement have changed. Even today, the requirement goes by different names; some say “nonobvious,” some “unobvious,” and other variations abound. In this chapter, we’ll learn how this requirement evolved and how it is applied and understood today.

### A. From “Invention” to “Nonobviousness”

This section will trace the development of this doctrine from its the nineteenth century origins to the Supreme Court’s first decisions under the Patent Act of 1952.

*Hotchkiss v. Greenwood*  
52 U.S. 248 (1850)

Mr. Justice NELSON delivered the opinion of the court.

This is a writ of error to the Circuit Court of the United States for the District of Ohio.

The suit was brought against the defendants for the alleged infringement of a patent for a new and useful improvement in making door and other knobs of all kinds of clay used in pottery, and of porcelain.

The improvement consists in making the knobs of clay or porcelain, and in fitting them for their application to doors, locks, and furniture, and various other uses to which they may be adapted; but more especially in this, that of having the cavity in the knob in which the screw or shank is inserted, and by which it is fastened, largest at the bottom and in the form of dovetail, or wedge reversed, and a screw formed therein by pouring in metal in a fused state; and, after referring to drawings of the article thus made, the patentees conclude as follows: “What we claim as our invention, and desire to secure by letters patent, is the manufacturing of knobs, as stated in the foregoing specifications, of potter’s clay, or any kind of clay used in pottery, and shaped and finished by moulding, turning, burning, and glazing; and also of porcelain.”

...

The court . . . charged the jury that [the patent would be invalid] if knobs of the same form and for the same purposes as that claimed by the patentees, made of metal or other material, had been before known and used; and if the spindle and shank, in the form used by them, had been before known and used, and had been attached to the metallic knob by means of a cavity in the form of dovetail and infusion of melted metal, the same as the mode claimed by the patentees, in the attachment of the shank and spindle to their knob; and the knob of clay was simply the substitution of one material for another, the spindle and shank being the same as before in common use, and also the mode of connecting them by dovetail to the knob the same as before in common use, and no more ingenuity or skill required to construct the knob in this way than that possessed by an ordinary mechanic acquainted with the business . . . .

This instruction, it is claimed, is erroneous, and one for which a new trial should be granted.

The instruction assumes, and, as was admitted on the argument, properly assumes, that knobs of metal, wood, &c., connected with a shank and spindle, in the mode and by the means used by the patentees in their manufacture, had been before known, and were in public use at the date of the patent; and hence the only novelty which could be claimed on their part was the adaptation of this old contrivance to knobs of potter's clay or porcelain; in other words, the novelty consisted in the substitution of the clay knob in the place of one made of metal or wood, as the case might be. And in order to appreciate still more clearly the extent of the novelty claimed, it is proper to add, that this knob of potter's clay is not new, and therefore constitutes no part of the discovery. If it was, a very different question would arise; as it might very well be urged, and successfully urged, that a knob of a new composition of matter, to which this old contrivance had been applied, and which resulted in a new and useful article, was the proper subject of a patent.

The novelty would consist in the new composition made practically useful for the purposes of life, by the means and contrivances mentioned. It would be a new manufacture, and none the less so, within the meaning of the patent law, because the means employed to adapt the new composition to a useful purpose was old, or well known.

But in the case before us, the knob is not new, nor the metallic shank and spindle, nor the dovetail form of the cavity in the knob, nor the means by which the metallic shank is securely fastened therein. All these were well known, and in common use; and the only thing new is the substitution of a knob of a different material from that heretofore used in connection with this arrangement.

Now it may very well be, that, by connecting the clay or porcelain knob with the metallic shank in this well-known mode, an article is produced better and cheaper than in

## NONOBVIOUSNESS

the case of the metallic or wood knob; but this does not result from any new mechanical device or contrivance, but from the fact, that the material of which the knob is composed happens to be better adapted to the purpose for which it is made. The improvement consists in the superiority of the material, and which is not new, over that previously employed in making the knob.

But this, of itself, can never be the subject of a patent. . . .

. . .

Now if the foregoing view of the improvement claimed in this patent be correct, . . . there was an absence of that degree of skill and ingenuity which constitute essential elements of every invention. In other words, the improvement is the work of the skilful mechanic, not that of the inventor.

We think, therefore, that the judgment is, and must be, affirmed.

### Context & Application

1. What is the source of the *Hotchkiss* “invention” requirement? Does it come from the statute or was it a judge-made doctrine?

2. At the end of *Hotchkiss*, the Supreme Court suggests that something must be the work of an “inventor,” not a “mechanic” to be patentable. What do you think it meant by that? Are “inventors” and “skillful mechanics” mutually exclusive categories?

3. The Court mentions that *Hotchkiss* was on appeal from the Circuit Court of the United States for the District of Ohio. Before 1891, patent cases were appealable directly to the Supreme Court. After that, all the appeals went to the regional circuits until 1982, when Congress created the Federal Circuit. What benefits can you see to each of these allocations of appellate jurisdiction? What are the potential costs?

4. Following *Hotchkiss*, the novelty-plus requirement was generally referred to as a requirement of “invention” or sometimes, “patentable novelty” or “inventive genius.” Which of these terms, if any, seem to best capture what the Court was concerned about in *Hotchkiss*?



Fast forward almost 100 years. In 1941, the Supreme Court issued its decision in *Cuno Engineering Corp. v. Automatic Devices Corp.* The asserted claims were directed to “improvements in lighters, commonly found in automobiles, for cigars, cigarettes and pipes.” The Supreme Court held they were not patentable:

## CHAPTER 7

We may concede that the functions performed by Mead's combination were new and useful. But that does not necessarily make the device patentable. Under the statute, the device must not only be "new and useful", it must also be an "invention" or "discovery." Since *Hotchkiss v. Greenwood*, decided in 1851, it has been recognized that if an improvement is to obtain the privileged position of a patent more ingenuity must be involved than the work of a mechanic skilled in the art. "Perfection of workmanship, however much it may increase the convenience, extend the use, or diminish expense, is not patentable." The principle of the *Hotchkiss* case applies to the adaptation or combination of old or well known devices for new uses. That is to say the new device, however useful it may be, *must reveal the flash of creative genius not merely the skill of the calling*. If it fails, it has not established its right to a private grant on the public domain.

Tested by that principle Mead's device was not patentable. We cannot conclude that his skill in making this contribution reached the level of inventive genius which the Constitution, Art. I, § 8, authorizes Congress to reward. He merely incorporated the well-known thermostat into the old "wireless" lighter to produce a more efficient, useful and convenient article. A new application of an old device may not be patented if the "result claimed as new is the same in character as the original result" even though the new result had not before been contemplated. Certainly the use of a thermostat to break a circuit in a "wireless" cigar lighter is analogous to or the same in character as the use of such a device in electric heaters, toasters, or irons, whatever may be the difference in detail of design. Ingenuity was required to effect the adaptation, but no more than that to be expected of a mechanic skilled in the art.

314 U.S. 84, 90–92 (1941) (emphasis added). Is this a fair reading of *Hotchkiss*? What does *Cuno* suggest the basis is for *Hotchkiss*'s novelty-plus requirement?

*Great Atlantic & Pac. Tea Co. v. Supermarket Equip. Corp.*  
340 U.S. 147 (1950)

Mr. Justice JACKSON delivered the opinion of the Court.

Two courts below have concurred in holding three patent claims to be valid, and it is stipulated that, if valid, they have been infringed. The issue, for the resolution of which we granted certiorari, is whether they applied correct criteria of invention. We hold that they have not, and that by standards appropriate for a combination patent these claims are invalid.

## NONOBVIOUSNESS

Stated without artifice, the claims assert invention of a cashier's counter equipped with a three-sided frame, or rack, with no top or bottom, which, when pushed or pulled, will move groceries deposited within it by a customer to the checking clerk and leave them there when it is pushed back to repeat the operation. It is kept on the counter by guides. That the resultant device works as claimed, speeds the customer on his way, reduces checking costs for the merchant, has been widely adopted and successfully used, appear beyond dispute.

The District Court explicitly found that each element in this device was known to prior art. "However," it found, "the conception of a counter with an extension to receive a bottomless self-unloading tray with which to push the contents of the tray in front of the cashier was a decidedly novel feature and constitutes a new and useful combination."

The Court of Appeals regarded this finding of invention as one of fact, sustained by substantial evidence, and affirmed it as not clearly erroneous. . . .

...

While this Court has sustained combination patents, it never has ventured to give a precise and comprehensive definition of the test to be applied in such cases. The voluminous literature which the subject has excited discloses no such test. It is agreed that the key to patentability of a mechanical device that brings old factors into cooperation is presence or lack of invention. In course of time the profession came to employ the term "combination" to imply its presence and the term "aggregation" to signify its absence, thus making antonyms in legal art of words which in ordinary speech are more nearly synonyms. However useful as words of art to denote in short form that an assembly of units has failed or has met the examination for invention, their employment as tests to determine invention results in nothing but confusion. The concept of invention is inherently elusive when applied to combination of old elements. This, together with the imprecision of our language, have counselled courts and text writers to be cautious in affirmative definitions or rules on the subject.

...

Neither court below has made any finding that old elements which made up this device perform any additional or different function in the combination than they perform out of it. This counter does what a store counter always has done—it supports merchandise at a convenient height while the customer makes his purchases and the merchant his sales. The three-sided rack will draw or push goods put within it from one place to another—just what any such a rack would do on any smooth surface—and the guide rails keep it from falling or sliding off from the counter, as guide rails have ever done. Two and two have been added together, and still they make only four.

Courts should scrutinize combination patent claims with a care proportioned to the difficulty and improbability of finding invention in an assembly of old elements. The function of a patent is to add to the sum of useful knowledge. Patents cannot be sustained when, on the contrary, their effect is to subtract from former resources freely available to skilled artisans. A patent for a combination which only unites old elements with no change in their respective functions, such as is presented here, obviously withdraws what already is known into the field of its monopoly and diminishes the resources available to skillful men. This patentee has added nothing to the total stock of knowledge, but has merely brought together segments of prior art and claims them in congregation as a monopoly.

The Court of Appeals and the respondent both lean heavily on evidence that this device filled a long-felt want and has enjoyed commercial success. But commercial success without invention will not make patentability. The courts below concurred in finding that every element here claimed (except extension of the counter) was known to prior art. When, for the first time, those elements were put to work for the supermarket type of stores, although each performed the same mechanical function for them that it had been known to perform, they produced results more striking, perhaps, than in any previous utilization. To bring these devices together and apply them to save the time of customer and checker was a good idea, but scores of progressive ideas in business are not patentable, and we conclude on the findings below that this one was not.

. . . The defect that we find in this judgment is that a standard of invention appears to have been used that is less exacting than that required where a combination is made up entirely of old components. It is on this ground that the judgment below is reversed.

Reversed.

Mr. Justice DOUGLAS, with whom Mr. Justice BLACK agrees, concurring.

It is worth emphasis that every patent case involving validity presents a question which requires reference to a standard written into the Constitution. Article I, § 8, contains a grant to the Congress of the power to permit patents to be issued. But unlike most of the specific powers which Congress is given, that grant is qualified. The Congress does not have free reign, for example, to decide that patents should be easily or freely given. The Congress acts under the restraint imposed by the statement of purpose in Art. I, § 8. The purpose is "To promote the Progress of Science and useful Arts." The means for achievement of that end is the grant for a limited time to inventors of the exclusive right to their inventions.

Every patent is the grant of a privilege of exacting tolls from the public. The Framers plainly did not want those monopolies freely granted. The invention, to justify a patent, had to serve the ends of science—to push back the frontiers of chemistry, physics, and the

## NONOBVIOUSNESS

like; to make a distinctive contribution to scientific knowledge. That is why through the years the opinions of the Court commonly have taken “inventive genius” as the test. It is not enough that an article is new and useful. The Constitution never sanctioned the patenting of gadgets. Patents serve a higher end—the advancement of science. An invention need not be as startling as an atomic bomb to be patentable. But it has to be of such quality and distinction that masters of the scientific field in which it falls will recognize it as an advance. Mr. Justice Bradley stated in *Atlantic Works v. Brady*, 107 U.S. 192, 200, the consequences of a looser standard:

It was never the object of those laws to grant a monopoly for every trifling device, every shadow of a shade of an idea, which would naturally and spontaneously occur to any skilled mechanic or operator in the ordinary progress of manufactures. Such an indiscriminate creation of exclusive privileges tends rather to obstruct than to stimulate invention. It creates a class of speculative schemers who make it their business to watch the advancing wave of improvement, and gather its foam in the form of patented monopolies, which enable them to lay a heavy tax upon the industry of the country, without contributing anything to the real advancement of the arts. It embarrasses the honest pursuit of business with fears and apprehensions of concealed liens and unknown liabilities to lawsuits and vexatious accountings for profits made in good faith.

...

The attempts through the years to get a broader, looser conception of patents than the Constitution contemplates have been persistent. The Patent Office, like most administrative agencies, has looked with favor on the opportunity which the exercise of discretion affords to expand its own jurisdiction. And so it has placed a host of gadgets under the armour of patents—gadgets that obviously have had no place in the constitutional scheme of advancing scientific knowledge. A few that have reached this Court show the pressure to extend monopoly to the simplest of devices:

*Hotchkiss v. Greenwood*, 11 How. 248: Doorknob made of clay rather than metal or wood, where different shaped door knobs had previously been made of clay.

*Rubber-Tip Pencil Co. v. Howard*, 20 Wall. 498: Rubber caps put on wood pencils to serve as erasers.

*Union Paper Collar Co. v. Van Dusen*, 23 Wall. 530: Making collars of parchment paper where linen paper and linen had previously been used.

*Brown v. Piper*, 91 U.S. 37: A method for preserving fish by freezing them in a container operating in the same manner as an ice cream freezer.

...

The patent involved in the present case belongs to this list of incredible patents which the Patent Office has spawned. The fact that a patent as flimsy and as spurious as this one has to be brought all the way to this Court to be declared invalid dramatically illustrates how far our patent system frequently departs from the constitutional standards which are supposed to govern.

### Context & Application

1. What is a “combination patent,” as that term is used in *Great A&P*?

2. The Court says that the commercial embodiment of (i.e., the product covered by) the patent at issue in *Great A&P* had “been widely adopted and successfully used.” Why wasn’t that enough to make the patent valid? What factors, other than “invention,” might make a product successful in the marketplace?

3. The concurrence suggests that we can’t trust the USPTO to correctly delineate the contours of patentability. Why not? Are there any reasons to think the USPTO might actually do a good job? And are there any reasons to think that courts would do better?

4. In *Great A&P*, the court starts by saying that three lower courts had held the asserted claims “to be valid.” But, based on the law today, it’s more accurate to say that those lower courts had held the patents to be “not invalid.” Because patents are entitled to a presumption of validity, *see* 35 U.S.C. § 282, and because the party challenging a patent’s validity bears the burden of proof, a court never actually decides that a patent-in-suit “is valid.” Instead, the question before the court is whether or not the challenger has proved that the patent is invalid. *See Durango Assocs., Inc. v. Reflange, Inc.*, 843 F.2d 1349, 1356 n.4 (Fed. Cir. 1988) (“A patent should not be declared ‘valid’ by a court because other challengers may be able to prove invalidity using different evidence.”). *See also Ball Aerosol & Specialty Container, Inc. v. Ltd. Brands, Inc.*, 555 F.3d 984, 994 (Fed. Cir. 2009) (“To the extent that the district court declared the patent ‘valid,’ or all the claims of the patent ‘valid,’ we vacate that declaration. Aside from the fact that courts do not declare patents to be valid, and only declare that they have not been proved to be invalid . . .”). This is not just a semantic distinction. Patent owners often assert the same patent claims against multiple parties. A patent owner can’t just pick the weakest target to sue first and then, if they prevail on the issue of validity, use that judgment to estop other accused infringers from challenging the patent. As a matter of due process, each accused infringer is entitled to its own opportunity to challenge the patent. *See Blonder-Tongue Labs., Inc. v. Univ. of Illinois Found.*, 402 U.S. 313, 329 (1971). But once a court holds a patent claim invalid, it should be invalid against the world. *See id.* Should patent validity be a one-way ratchet? Can you see any good reasons for this asymmetry? Any potential problems?



## NONOBVIOUSNESS



The opinion in *Great A&P* was briefed and decided while the Patent Act of 1952 was drafted. See Giles S. Rich, *Congressional Intent - or, Who Wrote the Patent Act of 1952*, 1 PATENT PROCUREMENT AND EXPLOITATION: PROTECTING INTELLECTUAL RIGHTS 61, 70 (1963). According to Giles Sutherland Rich, a patent attorney who helped draft the 1952 Act (and who was later appointed to the C.C.P.A.):

The Patent Act was written basically . . . by patent lawyers drawn from the Patent Office, from industry, from private practice, and from some government departments. They, in turn, drew upon the combined judgment of organizations of patent lawyers in a most remarkable way. They got the bill together, refined it, and presented it to the legislature to be enacted.

*Id.* at 73. Do you think this is a common or uncommon method for drafting federal statutes? How, if at all, should this drafting process affect the way we think about or interpret the 1952 Act? If a new patent statute were drafted today, which additional stakeholders do you think should be at the table?

One of the other drafters of the 1952 Act was Patent Office Examiner-in-Chief P. J. Federico. In his official commentary on the 1952 Act, Federico stated:

Patentable novelty or invention (section 103). The Committee Report state[s], in the general part, that one of the two “major changes or innovations” in the new statute consisted in “incorporating a requirement for invention in section 103.” Section 103 states that “A patent may not be obtained though the invention is not identically disclosed or described as set forth in section 102 of this title, if the differences between the subject matter sought to be patented and the prior art are such that the subject matter as a whole would have been obvious at the time the invention was made to a person having ordinary skill in the art to which said subject matter pertains. Patentability shall not be negated by the manner in which the invention was made.”

In form this section is a limitation on section 102 and it should more logically have been made part of section 102, but it was made a separate section to prevent 102 from becoming too long and involved and because of its importance.

*Commentary on the New Patent Act*, 75 J. PAT. & TRADEMARK OFF. SOC’Y 161, 180 (1993), reprinted from Title 35, United States Code Annotated (1954 ed.). Even after the enactment of § 103, “[t]he problem of what is obvious and hence not patentable is still of necessity one of judgment,” noting that “[t]he statute does not purport to categorize the particular criteria according to which the judgment is to be exercised . . . .” *Id.* at 184.

Thus, the question of how to apply this new provision—and what it might mean for the *Hotchkiss* “invention” standard—was left to the courts. It took over a decade for that question to reach the Supreme Court. On a single day in 1966, the Court decided its first three § 103 cases. The first one, *Graham v. John Deere*, included an extensive analysis of the constitutional framework, judicial development, and legislative action regarding what we now call “nonobviousness.” We’ll read that analysis first, then consider the Court’s application of its new framework in the notes.

*Graham v. John Deere Co.*  
383 U.S. 1 (1966)

Mr. Justice CLARK delivered the opinion of the Court.

After a lapse of 15 years, the Court again focuses its attention on the patentability of inventions under the standard of Art. I, § 8, cl. 8, of the Constitution and under the conditions prescribed by the laws of the United States. Since our last expression on patent validity, *Great A. & P. Tea Co. v. Supermarket Equipment Corp.*, the Congress has for the first time expressly added a third statutory dimension to the two requirements of novelty and utility that had been the sole statutory test since the Patent Act of 1793. This is the test of obviousness, i.e., whether “the subject matter sought to be patented and the prior art are such that the subject matter as a whole would have been obvious at the time the invention was made to a person having ordinary skill in the art to which said subject matter pertains. Patentability shall not be negated by the manner in which the invention was made.” 35 U.S.C. § 103 (1964 ed.).

The questions, involved in each of the companion cases before us, are what effect the 1952 Act had upon traditional statutory and judicial tests of patentability and what definitive tests are now required. We have concluded that the 1952 Act was intended to codify judicial precedents embracing the principle long ago announced by this Court in *Hotchkiss v. Greenwood*, and that, while the clear language of § 103 places emphasis on an inquiry into obviousness, the general level of innovation necessary to sustain patentability remains the same.

...

II

At the outset it must be remembered that the federal patent power stems from a specific constitutional provision which authorizes the Congress “To promote the Progress of . . . useful Arts, by securing for limited Times to . . . Inventors the exclusive Right to their . . . Discoveries.” Art. I, § 8, cl. 8.1 The clause is both a grant of power and a limitation. This qualified authority, unlike the power often exercised in the sixteenth and seventeenth

## NONOBVIOUSNESS

centuries by the English Crown, is limited to the promotion of advances in the “useful arts.” It was written against the backdrop of the practices—eventually curtailed by the Statute of Monopolies—of the Crown in granting monopolies to court favorites in goods or businesses which had long before been enjoyed by the public. The Congress in the exercise of the patent power may not overreach the restraints imposed by the stated constitutional purpose. Nor may it enlarge the patent monopoly without regard to the innovation, advancement or social benefit gained thereby. Moreover, Congress may not authorize the issuance of patents whose effects are to remove existent knowledge from the public domain, or to restrict free access to materials already available. Innovation, advancement, and things which add to the sum of useful knowledge are inherent requisites in a patent system which by constitutional command must “promote the Progress of . . . useful Arts.” This is the standard expressed in the Constitution and it may not be ignored. And it is in this light that patent validity “requires reference to a standard written into the Constitution.” *Great A. & P. Tea Co. v. Supermarket Equipment Corp.*, *supra* (concurring opinion).

Within the limits of the constitutional grant, the Congress may, of course, implement the stated purpose of the Framers by selecting the policy which in its judgment best effectuates the constitutional aim. This is but a corollary to the grant to Congress of any Article I power. Within the scope established by the Constitution, Congress may set out conditions and tests for patentability. It is the duty of the Commissioner of Patents and of the courts in the administration of the patent system to give effect to the constitutional standard by appropriate application, in each case, of the statutory scheme of the Congress.

Congress quickly responded to the bidding of the Constitution by enacting the Patent Act of 1790 during the second session of the First Congress. It created an agency in the Department of State headed by the Secretary of State, the Secretary of the Department of War and the Attorney General, any two of whom could issue a patent for a period not exceeding 14 years to any petitioner that “hath invented or discovered any useful art, manufacture, or device, or any improvement therein not before known or used” if the board found that “the invention or discovery (was) sufficiently useful and important.” 1 Stat. 110. This group, whose members administered the patent system along with their other public duties, was known by its own designation as “Commissioners for the Promotion of Useful Arts.”

Thomas Jefferson, who as Secretary of State was a member of the group, was its moving spirit and might well be called the “first administrator of our patent system.” See Federico, *Operation of the Patent Act of 1790*, 18 J. PAT. OFF. SOC. 237, 238 (1936). He was not only an administrator of the patent system under the 1790 Act, but was also the author of the 1793 Patent Act. In addition, Jefferson was himself an inventor of great note. His unpatented improvements on plows, to mention but one line of his inventions, won

acclaim and recognition on both sides of the Atlantic. Because of his active interest and influence in the early development of the patent system, Jefferson's views on the general nature of the limited patent monopoly under the Constitution, as well as his conclusions as to conditions for patentability under the statutory scheme, are worthy of note.

Jefferson, like other Americans, had an instinctive aversion to monopolies. It was a monopoly on tea that sparked the Revolution and Jefferson certainly did not favor an equivalent form of monopoly under the new government. His abhorrence of monopoly extended initially to patents as well. From France, he wrote to Madison urging a Bill of Rights provision restricting monopoly, and as against the argument that limited monopoly might serve to incite "ingenuity," he argued forcefully that "the benefit even of limited monopolies is too doubtful to be opposed to that of their general suppression."

...

Jefferson's philosophy on the nature and purpose of the patent monopoly is expressed in a letter to Isaac McPherson (Aug. 1813), a portion of which we set out in the margin.<sup>2</sup>

<sup>2</sup> "Stable ownership is the gift of social law, and is given late in the progress of society. It would be curious then, if an idea, the fugitive fermentation of an individual brain, could, of natural right, be claimed in exclusive and stable property. If nature has made any one thing less susceptible than all others of exclusive property, it is the action of the thinking power called an idea, which an individual may exclusively possess as long as he keeps it to himself; but the moment it is divulged, it forces itself into the possession of every one, and the receiver cannot dispossess himself of it. Its peculiar character, too, is that no one possesses the less, because every other possesses the whole of it. He who receives an idea from me, receives instruction himself without lessening mine; as he who lights his taper at mine, receives light without darkening me. That ideas should freely spread from one to another over the globe, for the moral and mutual instruction of man, and improvement of his condition, seems to have been peculiarly and benevolently designed by nature, when she made them, like fire, expansible over all space, without lessening their density in any point, and like the air in which we breathe, move, and have our physical being, incapable of confinement or exclusive appropriation. Inventions then cannot, in nature, be a subject of property. Society may give an exclusive right to the profits arising from them, as an encouragement to men to pursue ideas which may produce utility, but this may or may not be done, according to the will and convenience of the society, without claim or complaint from anybody." VI WRITINGS OF THOMAS JEFFERSON, at 180–181 (Washington ed.).

## NONOBVIOUSNESS

He rejected a natural-rights theory in intellectual property rights and clearly recognized the social and economic rationale of the patent system. The patent monopoly was not designed to secure to the inventor his natural right in his discoveries. Rather, it was a reward, an inducement, to bring forth new knowledge. The grant of an exclusive right to an invention was the creation of society—at odds with the inherent free nature of disclosed ideas—and was not to be freely given. Only inventions and discoveries which furthered human knowledge, and were new and useful, justified the special inducement of a limited private monopoly. Jefferson did not believe in granting patents for small details, obvious improvements, or frivolous devices. His writings evidence his insistence upon a high level of patentability.

### III

The difficulty of formulating conditions for patentability was heightened by the generality of the constitutional grant and the statutes implementing it, together with the underlying policy of the patent system that “the things which are worth to the public the embarrassment of an exclusive patent,” as Jefferson put it, must outweigh the restrictive effect of the limited patent monopoly. The inherent problem was to develop some means of weeding out those inventions which would not be disclosed or devised but for the inducement of a patent.

This Court formulated a general condition of patentability in 1851 in *Hotchkiss v. Greenwood*. The patent involved a mere substitution of materials—porcelain or clay for wood or metal in doorknobs—and the Court condemned it . . . .

*Hotchkiss*, by positing the condition that a patentable invention evidence more ingenuity and skill than that possessed by an ordinary mechanic acquainted with the business, merely distinguished between new and useful innovations that were capable of sustaining a patent and those that were not. The *Hotchkiss* test laid the cornerstone of the judicial evolution suggested by Jefferson and left to the courts by Congress. The language in the case, and in those which followed, gave birth to “invention” as a word of legal art signifying patentable inventions. Yet, as this Court has observed, “the truth is, the word ‘invention’ cannot be defined in such manner as to afford any substantial aid in determining whether a particular device involves an exercise of the inventive faculty or not.” Its use as a label brought about a large variety of opinions as to its meaning both in the Patent Office, in the courts, and at the bar. The *Hotchkiss* formulation, however, lies not in any label, but in its functional approach to questions of patentability. In practice, *Hotchkiss* has required a comparison between the subject matter of the patent, or patent application, and the background skill of the calling. It has been from this comparison that patentability was in each case determined.

## IV

The pivotal section around which the present controversy centers is § 103. It provides:

§ 103. Conditions for patentability; non-obvious subject matter

A patent may not be obtained though the invention is not identically disclosed or described as set forth in section 102 of this title, if the differences between the subject matter sought to be patented and the prior art are such that the subject matter as a whole would have been obvious at the time the invention was made to a person having ordinary skill in the art to which said subject matter pertains. Patentability shall not be negated by the manner in which the invention was made.

The section is cast in relatively unambiguous terms. Patentability is to depend, in addition to novelty and utility, upon the “non-obvious” nature of the “subject matter sought to be patented” to a person having ordinary skill in the pertinent art.

The first sentence of this section is strongly reminiscent of the language in *Hotchkiss*. Both formulations place emphasis on the pertinent art existing at the time the invention was made and both are implicitly tied to advances in that art. The major distinction is that Congress has emphasized “nonobviousness” as the operative test of the section, rather than the less definite “invention” language of *Hotchkiss* that Congress thought had led to “a large variety” of expressions in decisions and writings. In the title itself the Congress used the phrase “Conditions for patentability; *non-obvious subject matter*,” thus focusing upon “nonobviousness” rather than “invention.” . . .

It is undisputed that this section was . . . a statutory expression of an additional requirement for patentability, originally expressed in *Hotchkiss*. It also seems apparent that Congress intended by the last sentence of § 103 to abolish the test it believed this Court announced in the controversial phrase “flash of creative genius,” used in *Cuno Engineering Corp. v. Automatic Devices Corp.*

. . .

We believe that this legislative history, as well as other sources, shows that the revision was not intended by Congress to change the general level of patentable invention. We conclude that the section was intended merely as a codification of judicial precedents embracing the *Hotchkiss* condition, with congressional directions that inquiries into the obviousness of the subject matter sought to be patented are a prerequisite to patentability.

Approached in this light, the § 103 additional condition, when followed realistically, will permit a more practical test of patentability. The emphasis on non-obviousness is one of inquiry, not quality, and, as such, comports with the constitutional strictures.

While the ultimate question of patent validity is one of law, the § 103 condition, which is but one of three conditions, each of which must be satisfied, lends itself to several basic factual inquiries. Under § 103, the scope and content of the prior art are to be determined; differences between the prior art and the claims at issue are to be ascertained; and the level of ordinary skill in the pertinent art resolved. Against this background, the obviousness or nonobviousness of the subject matter is determined. Such secondary considerations as commercial success, long felt but unsolved needs, failure of others, etc., might be utilized to give light to the circumstances surrounding the origin of the subject matter sought to be patented. As indicia of obviousness or nonobviousness, these inquiries may have relevancy. See Note, *Subtests of "Nonobviousness": A Nontechnical Approach to Patent Validity*, 112 U. PA. L. REV. 1169 (1964).

This is not to say, however, that there will not be difficulties in applying the nonobviousness test. What is obvious is not a question upon which there is likely to be uniformity of thought in every given factual context. The difficulties, however, are comparable to those encountered daily by the courts in such frames of reference as negligence and scienter, and should be amenable to a case-by-case development. We believe that strict observance of the requirements laid down here will result in that uniformity and definiteness which Congress called for in the 1952 Act.

...

Although we conclude here that the inquiry which the Patent Office and the courts must make as to patentability must be beamed with greater intensity on the requirements of § 103, it bears repeating that we find no change in the general strictness with which the overall test is to be applied. . . .

### Context & Application

1. In *Graham*, the Supreme Court lays out a framework for analyzing § 103 cases but doesn't tell us how to apply that framework. The Court did, however, apply its own framework three in three cases decided that day—*Graham v. John Deere Co.*, the *Cook Chemical* cases, and *United States v. Adams*, 383 U.S. 39 (1966).

a. *Graham v. John Deere Co.*

This case involved “the validity of a single patent on a ‘Clamp for vibrating Shank Plows.’ The invention, a combination of old mechanical elements, involves a device designed to absorb shock from plow shanks as they plow through rocky soil and thus to prevent damage to the plow.” *Graham v. John Deere Co.*, 383 U.S. 1, 4 (1966). The Court provided the following illustration:

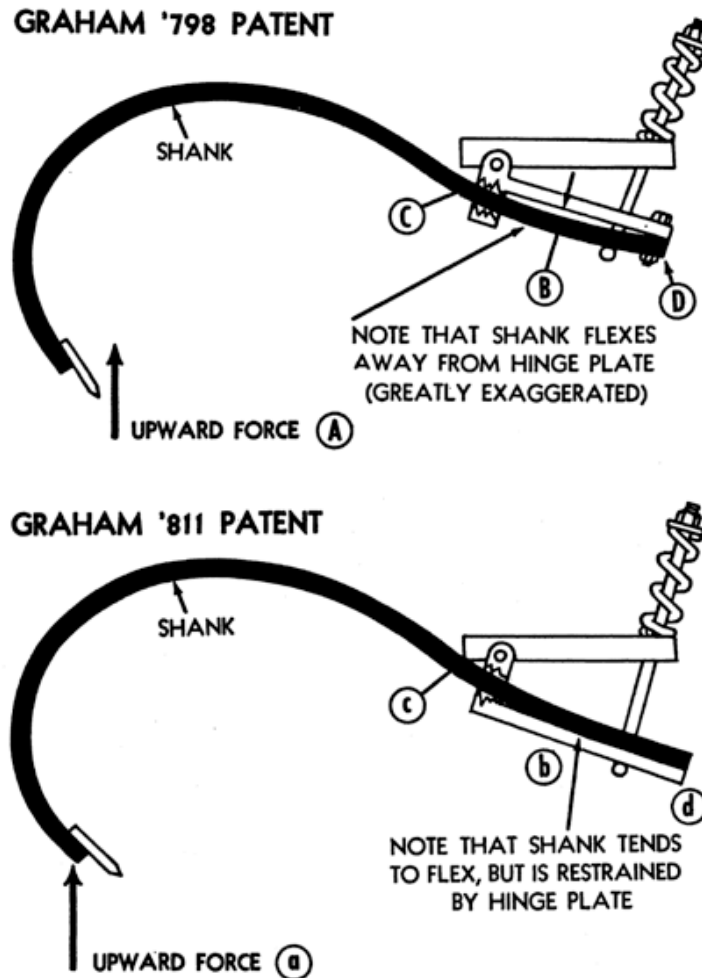

The Court analyzed the issue of nonobviousness as follows:

The sole element in patent '798 which petitioners argue [makes the invention nonobvious] before us is the interchanging of the shank and hinge plate and the consequences flowing from this arrangement. The contention is that this arrangement—which petitioners claim is not disclosed in the prior art—permits



## NONOBVIOUSNESS

the shank to flex under stress for its entire length. As we have sketched (see sketch, “Graham ’798 Patent” in Appendix, Fig. 2), when the chisel hits an obstruction the resultant force (A) pushes the rear of the shank upward and the shank pivots against the rear of the hinge plate at (C). The natural tendency is for that portion of the shank between the pivot point and the bolted connection (i.e., between C and D) to bow downward and away from the hinge plate. The maximum distance (B) that the shank moves away from the plate is slight—for emphasis, greatly exaggerated in the sketches. This is so because of the strength of the shank and the short—nine inches or so—length of that portion of the shank between (C) and (D). On the contrary, in patent ’811 (see sketch, “Graham ’811 Patent” in Appendix, Fig. 2), the pivot point is the upper plate at point (c); and while the tendency for the shank to bow between points (c) and (d) is the same as in ’798, the shank is restricted because of the underlying hinge plate and cannot flex as freely. In practical effect, the shank flexes only between points (a) and (c), and not along the entire length of the shank, as in ’798.

The patent owner argued “that this difference in flex, though small, effectively absorbs the tremendous forces of the shock of obstructions whereas prior art arrangements failed.” According to the Court, this difference was not enough to make the improvement patentable:

We assume that the prior art does not disclose such an arrangement as petitioners claim in patent ’798. Still we do not believe that the argument on which petitioners’ contention is bottomed supports the validity of the patent. The tendency of the shank to flex is the same in all cases. If free-flexing, as petitioners now argue, is the crucial difference above the prior art, then it appears evident that the desired result would be obtainable by not boxing the shank within the confines of the hinge. The only other effective place available in the arrangement was to attach it below the hinge plate and run it through a stirrup or bracket that would not disturb its flexing qualities. Certainly a person having ordinary skill in the prior art, given the fact that the flex in the shank could be utilized more effectively if allowed to run the entire length of the shank, would immediately see that the thing to do was what Graham did, i.e., invert the shank and the hinge plate.

...

We find no nonobvious facets in the ’798 arrangement. The wear and repair claims were sufficient to overcome the patent examiner’s original conclusions as to the validity of the patent. However, some of the prior art, notably Glencoe, was not before him. There the hinge plate is below the shank but, as the courts below found, all of the elements in the ’798 patent are present in the Glencoe structure. Furthermore, even though the position of the shank and hinge plate appears

reversed in Glencoe, the mechanical operation is identical. The shank there pivots about the underside of the stirrup, which in Glencoe is above the shank. In other words, the stirrup in Glencoe serves exactly the same function as the heel of the hinge plate in '798. The mere shifting of the wear point to the heel of the '798 hinge plate from the stirrup of Glencoe—itself a part of the hinge plate—presents no operative mechanical distinctions, much less nonobvious differences.

Thus, the court concluded that the '798 patent was invalid as obvious.

b. The *Cook Chemical* cases

These consolidated cases, *Calmar, Inc. v. Cook Chemical Co.* and *Colgate-Palmolive Co. v. Cook Chemical Co.*, involved “a finger-operated sprayer with a ‘hold-down’ cap of the type commonly seen on grocers’ shelves inserted in bottles of insecticides and other liquids prior to shipment.” *Graham v. John Deere Co. of Kansas City*, 383 U.S. 1, 4 (1966). The sprayer was invented by “an officer of Cook Chemical, Scoggin,” so the court refers to it as “the Scoggins patent.” *See id.* at 28. After describing the patented invention and prior art in detail, the Court focused on what it called the “distinguishing features” in Scoggins’ claims—“the space between the skirt of the overcap and the container cap” and “[t]he substitution of a rib built into a collar”:

As to the space between the skirt of the overcap and the container cap, the District Court found: “Certainly without a space so described, there could be no inner seal within the cap, but such a space is not new or novel, but it is necessary to the formation of the seal within the hold-down cap.”

“To me this language is descriptive of an element of the patent but not a part of the invention. It is too simple, really, to require much discussion. In this device the hold-down cap was intended to perform two functions—to hold down the sprayer head and to form a solid tight seal between the shoulder and the collar below. In assembling the element it is necessary to provide this space in order to form the seal.”

The court correctly viewed the significance of that feature. We are at a loss to explain the Examiner’s allowance on the basis of such a distinction. Scoggin was able to convince the Examiner that Mellon’s cap contacted the bottle neck while his did not. . . . Moreover, the space so strongly asserted by Cook Chemical appears quite plainly on the Livingstone device, a reference not cited by the Examiner.

The substitution of a rib built into a collar likewise presents no patentable difference above the prior art. It was fully disclosed and dedicated to the public in the Livingstone patent. Cook Chemical argues, however, that Livingstone is not in the pertinent prior art because it relates to liquid containers having pouring spouts

## NONOBVIOUSNESS

rather than pump sprayers. Apart from the fact that respondent made no such objection to similar references cited by the Examiner, so restricted a view of the applicable prior art is not justified. The problems confronting Scoggin and the insecticide industry were not insecticide problems; they were mechanical closure problems. Closure devices in such a closely related art as pouring spouts for liquid containers are at the very least pertinent references.

The Court included this drawing, figure 3 from the Scoggins patent (U.S. Patent No. 2,870,943), in the appendix to its decision:

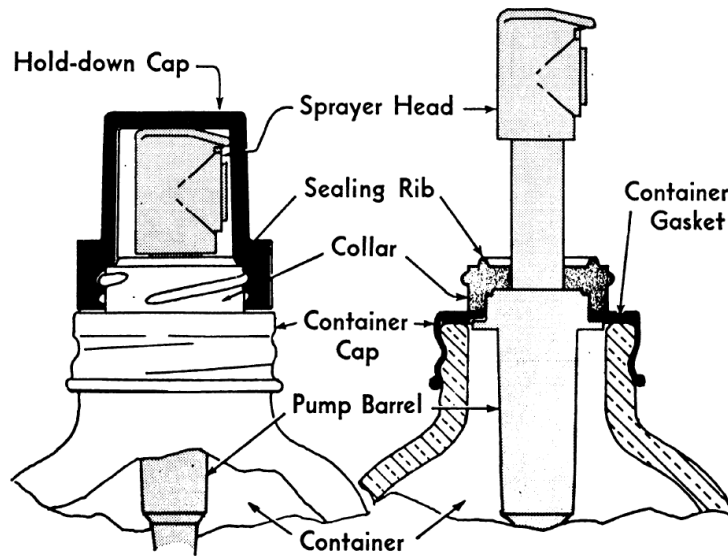

The Court also rejected Cook Chemical's arguments about certain secondary considerations:

Cook Chemical insists, however, that the development of a workable shipper-sprayer eluded Calmar, who had long and unsuccessfully sought to solve the problem. And, further, that the long-felt need in the industry for a device such as Scoggin's together with its wide commercial success supports its patentability. These legal inferences or subttests do focus attention on economic and motivational rather than technical issues and are, therefore, more susceptible of judicial treatment than are the highly technical facts often present in patent litigation. Such inquiries may lend a helping hand to the judiciary which, as Mr. Justice Frankfurter observed, is most ill-fitted to discharge the technological duties cast upon it by patent legislation. They may also serve to "guard against slipping into

use of hindsight” and to resist the temptation to read into the prior art the teachings of the invention in issue.

However, these factors do not, in the circumstances of this case, tip the scales of patentability. The Scoggin invention, as limited by the Patent Office and accepted by Scoggin, rests upon exceedingly small and quite non-technical mechanical differences in a device which was old in the art. . . . To us, the limited claims of the Scoggin patent are clearly evident from the prior art as it stood at the time of the invention.

Therefore, the Court concluded that the invention claimed in the Scoggin patent was invalid as obvious.

c. *United States v. Adams*

In a third case decided the same day as *John Deere*, the Court considered the validity of U.S. Patent No. 2,322,210, which was directed to a nonrechargeable electric battery. See *United States v. Adams*, 383 U.S. 39, 42 (1966). According to the Court, the claimed battery “comprises two electrodes—one made of magnesium, the other of cuprous chloride—which are placed in a container. The electrolyte, or battery fluid, used may be either plain or salt water.” As the Court explained:

The specifications of the patent state that the object of the invention is to provide constant voltage and current without the use of acids, conventionally employed in storage batteries, and without the generation of dangerous fumes. Another object is “to provide a battery which is relatively light in weight with respect to capacity” and which “may be manufactured and distributed to the trade in a dry condition and rendered serviceable by merely filling the container with water.”

At that point, batteries were not new. But the Adams battery had several advantages over the prior art:

The Adams invention was the first practical, water-activated, constant potential battery which could be fabricated and stored indefinitely without any fluid in its cells. It was activated within 30 minutes merely by adding water. Once activated, the battery continued to deliver electricity at a voltage which remained essentially constant regardless of the rate at which current was withdrawn. Furthermore, its capacity for generating current was exceptionally large in comparison to its size and weight. The battery was also quite efficient in that substantially its full capacity could be obtained over a wide range of currents. . . . [T]hese chemical reactions were highly exothermic, liberating large quantities of heat during operation. . . . Relatively high temperatures would not damage the battery.

## NONOBVIOUSNESS

Consequently, the battery was operable from 65 below zero Fahrenheit to 200 Fahrenheit.

After describing the patented invention and prior art in detail, the Court analyzed the issue of nonobviousness as follows:

We conclude the Adams battery was also nonobvious. . . . [T]he operating characteristics of the Adams battery have been shown to have been unexpected and to have far surpassed then-existing wet batteries. Despite the fact that each of the elements of the Adams battery was well known in the prior art, to combine them as did Adams required that a person reasonably skilled in the prior art must ignore that (1) batteries which continued to operate on an open circuit and which heated in normal use were not practical; and (2) water-activated batteries were successful only when combined with electrolytes detrimental to the use of magnesium. These long-accepted factors, when taken together, would, we believe, deter any investigation into such a combination as is used by Adams. This is not to say that one who merely finds new uses for old inventions by shutting his eyes to their prior disadvantages thereby discovers a patentable innovation. We do say, however, that known disadvantages in old devices which would naturally discourage the search for new inventions may be taken into account in determining obviousness.

Nor are these the only factors bearing on the question of obviousness. We have seen that at the time Adams perfected his invention noted experts expressed disbelief in it. Several of the same experts subsequently recognized the significance of the Adams invention, some even patenting improvements on the same system. Furthermore, in a crowded art replete with a century and a half of advancement, the Patent Office found not one reference to cite against the Adams application.

Does this analysis suggest any other secondary considerations that might be relevant to the question of nonobviousness?

2. In *Graham*, the Court says that, in evaluating the issue of obviousness, courts may utilize “secondary considerations” in order “to give light to the circumstances surrounding the origin of the subject matter sought to be patented.” 383 U.S. 1, 17–18 (1966). The court lists three such considerations:

- Commercial success,
- Long felt but unsolved needs; and
- Failure of others.

In doing so, the Court cites a student note, Richard L. Robbins, Note, *Subtests of “Nonobviousness”: A Nontechnical Approach to Patent Validity*, 112 U. PA. L. REV. 1169 (1964).

That note suggested additional considerations, including “commercial acquiescence” as evidenced by licensing, “simultaneous solution” of a problem, and “professional approval.” *Id.* at 1178–82. Indeed, since *Graham*, courts have used other factors in analyzing issues of obviousness, including:

- Industry praise;
- Copying;
- Unexpected results;
- Licensing by the patentee; and
- Simultaneous invention.

Which way do (or should) each of these factors cut? Do any of these strike you as more or less useful in the ultimate inquiry—i.e., in determining whether a claimed invention would have been obvious to a person of ordinary skill in the art?

5. In a case decided later in the same year as *Graham*, the C.C.P.A. stated that: “We think the proper way to apply the 103 obviousness test to a case like this is to first picture the inventor as working in his shop with the prior art references—which he is presumed to know—hanging on the walls around him.” *In re Winslow*, 365 F.2d 1017, 1020 (C.C.P.A. 1966). Do you think most (if any) inventors actually work this way? Are they likely to be aware of everything in the prior art? If not, why did the C.C.P.A. frame the test this way? (Remember that the person of skill, from whose perspective obviousness is judged, is a hypothetical person, not a real person.) In any case, how does this “*Winslow* tableau” approach, which is still used today, affect how you think about the framework set forth in *Graham*?

## A. Nonobviousness Today

In this section, we’ll explore how the requirement of nonobviousness is understood and applied today. First, we’ll read the Supreme Court’s most recent decision on nonobviousness and see some examples of how the Federal Circuit has interpreted and applied that precedent. Then, we’ll explore the way courts have handled two of the *Graham* factors, namely: (1) What is the scope and content of the prior art? and (2) What is the level of skill in the art? Notice that one difference between novelty and nonobviousness is that a successful novelty challenge must be based on a single reference, while a successful nonobviousness challenge may (but need not be) based on multiple references.

## 1. The Modern Framework

The next case involves U.S. Patent No. 6,237,565 (referred to in the case as “the Engelau patent.” Here is figure 1 of the Engelau patent:

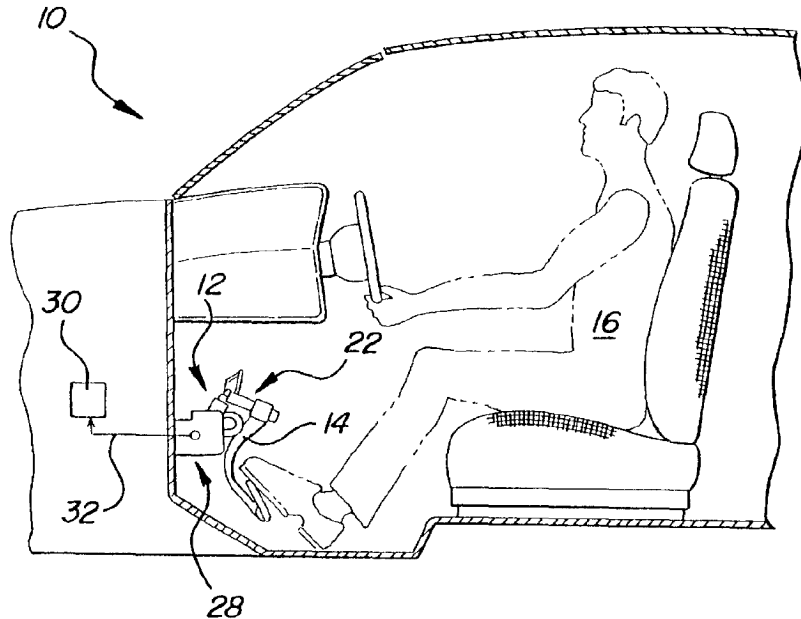

*KSR Int'l Co. v. Teleflex Inc.*  
550 U.S. 398 (2007)

Justice KENNEDY delivered the opinion of the Court.

Teleflex Incorporated and its subsidiary Technology Holding Company—both referred to here as Teleflex—sued KSR International Company for patent infringement. The patent at issue, United States Patent No. 6,237,565, is entitled “Adjustable Pedal Assembly With Electronic Throttle Control.” The patentee is Steven J. Engelgau, and the patent is referred to as “the Engelgau patent.” Teleflex holds the exclusive license to the patent.

Claim 4 of the Engelgau patent describes a mechanism for combining an electronic sensor with an adjustable automobile pedal so the pedal’s position can be transmitted to a computer that controls the throttle in the vehicle’s engine. When Teleflex accused KSR of infringing the Engelgau patent by adding an electronic sensor to one of KSR’s previously designed pedals, KSR countered that claim 4 was invalid under the Patent Act because its subject matter was obvious.

## CHAPTER 7

Section 103(a) forbids issuance of a patent when “the differences between the subject matter sought to be patented and the prior art are such that the subject matter as a whole would have been obvious at the time the invention was made to a person having ordinary skill in the art to which said subject matter pertains.”

...

Seeking to resolve the question of obviousness with more uniformity and consistency, the Court of Appeals for the Federal Circuit has employed an approach referred to by the parties as the “teaching, suggestion, or motivation” test (TSM test), under which a patent claim is only proved obvious if “some motivation or suggestion to combine the prior art teachings” can be found in the prior art, the nature of the problem, or the knowledge of a person having ordinary skill in the art. KSR challenges that test, or at least its application in this case. Because the Court of Appeals addressed the question of obviousness in a manner contrary to § 103 and our precedents, we granted certiorari. We now reverse.

I

A

In car engines without computer-controlled throttles, the accelerator pedal interacts with the throttle via cable or other mechanical link. . . .

In the 1990’s it became more common to install computers in cars to control engine operation. Computer-controlled throttles open and close valves in response to electronic signals, not through force transferred from the pedal by a mechanical link. Constant, delicate adjustments of air and fuel mixture are possible. The computer’s rapid processing of factors beyond the pedal’s position improves fuel efficiency and engine performance.

For a computer-controlled throttle to respond to a driver’s operation of the car, the computer must know what is happening with the pedal. A cable or mechanical link does not suffice for this purpose; at some point, an electronic sensor is necessary to translate the mechanical operation into digital data the computer can understand.

Before discussing sensors further we turn to the mechanical design of the pedal itself. In the traditional design a pedal can be pushed down or released but cannot have its position in the footwell adjusted by sliding the pedal forward or back. As a result, a driver who wishes to be closer or farther from the pedal must either reposition himself in the driver’s seat or move the seat in some way. In cars with deep footwells these are imperfect solutions for drivers of smaller stature. To solve the problem, inventors, beginning in the 1970’s, designed pedals that could be adjusted to change their location in the footwell. Important for this case are two adjustable pedals disclosed in U.S. Patent Nos. 5,010,782 (filed July 28, 1989) (Asano) and 5,460,061 (filed Sept. 17, 1993) (Redding). The Asano patent reveals a support structure that houses the pedal so that even when the pedal



location is adjusted relative to the driver, one of the pedal's pivot points stays fixed. The pedal is also designed so that the force necessary to push the pedal down is the same regardless of adjustments to its location. The Redding patent reveals a different, sliding mechanism where both the pedal and the pivot point are adjusted.

We return to sensors. Well before Engelgau applied for his challenged patent, some inventors had obtained patents involving electronic pedal sensors for computer-controlled throttles. These inventions, such as the device disclosed in U.S. Patent No. 5,241,936 ('936), taught that it was preferable to detect the pedal's position in the pedal assembly, not in the engine. The '936 patent disclosed a pedal with an electronic sensor on a pivot point in the pedal assembly. U.S. Patent No. 5,063,811 (Smith) taught that to prevent the wires connecting the sensor to the computer from chafing and wearing out, and to avoid grime and damage from the driver's foot, the sensor should be put on a fixed part of the pedal assembly rather than in or on the pedal's footpad.

In addition to patents for pedals with integrated sensors inventors obtained patents for self-contained modular sensors. A modular sensor is designed independently of a given pedal so that it can be taken off the shelf and attached to mechanical pedals of various sorts, enabling the pedals to be used in automobiles with computer-controlled throttles. One such sensor was disclosed in U.S. Patent No. 5,385,068 ('068). In 1994, Chevrolet manufactured a line of trucks using modular sensors "attached to the pedal assembly support bracket, adjacent to the pedal and engaged with the pivot shaft about which the pedal rotates in operation."

The prior art contained patents involving the placement of sensors on adjustable pedals as well. For example, U.S. Patent No. 5,819,593 (Rixon) discloses an adjustable pedal assembly with an electronic sensor for detecting the pedal's position. In the Rixon pedal the sensor is located in the pedal footpad. The Rixon pedal was known to suffer from wire chafing when the pedal was depressed and released.

This short account of pedal and sensor technology leads to the instant case.

## B

KSR, a Canadian company, manufactures and supplies auto parts, including pedal systems. Ford Motor Company hired KSR in 1998 to supply an adjustable pedal system for various lines of automobiles with cable-actuated throttle controls. KSR developed an adjustable mechanical pedal for Ford and obtained U.S. Patent No. 6,151,986 ('986) for the design. In 2000, KSR was chosen by General Motors Corporation (GMC or GM) to supply adjustable pedal systems for Chevrolet and GMC light trucks that used engines with computer-controlled throttles. To make the '986 pedal compatible with the trucks, KSR merely took that design and added a modular sensor.

## CHAPTER 7

Teleflex is a rival to KSR in the design and manufacture of adjustable pedals. As noted, it is the exclusive licensee of the Engelgau patent. Engelgau filed the patent application on August 22, 2000, as a continuation of a previous application for U.S. Patent No. 6,109,241, which was filed on January 26, 1999. He has sworn he invented the patent's subject matter on February 14, 1998. The Engelgau patent discloses an adjustable electronic pedal described in the specification as a "simplified vehicle control pedal assembly that is less expensive, and which uses fewer parts and is easier to package within the vehicle." Claim 4 of the patent, at issue here, describes:

A vehicle control pedal apparatus comprising:

- a support adapted to be mounted to a vehicle structure;
- an adjustable pedal assembly having a pedal arm moveable in for[e] and aft directions with respect to said support;
- a pivot for pivotally supporting said adjustable pedal assembly with respect to said support and defining a pivot axis; and
- an electronic control attached to said support for controlling a vehicle system;

said apparatus characterized by said electronic control being responsive to said pivot for providing a signal that corresponds to pedal arm position as said pedal arm pivots about said pivot axis between rest and applied positions wherein the position of said pivot remains constant while said pedal arm moves in fore and aft directions with respect to said pivot.

We agree with the District Court that the claim discloses "a position-adjustable pedal assembly with an electronic pedal position sensor attached to the support member of the pedal assembly. Attaching the sensor to the support member allows the sensor to remain in a fixed position while the driver adjusts the pedal."

Before issuing the Engelgau patent the U.S. Patent and Trademark Office (PTO) rejected one of the patent claims that was similar to, but broader than, the present claim 4. The claim did not include the requirement that the sensor be placed on a fixed pivot point. The PTO concluded the claim was an obvious combination of the prior art disclosed in Redding and Smith . . . . [According to the PTO,] Redding provided an example of an adjustable pedal, and Smith explained how to mount a sensor on a pedal's support structure, and the rejected patent claim merely put these two teachings together.

Although the broader claim was rejected, claim 4 was later allowed because it included the limitation of a fixed pivot point, which distinguished the design from Redding's. Engelgau had not included Asano among the prior art references, and Asano was not mentioned in the patent's prosecution. Thus, the PTO did not have before it an

adjustable pedal with a fixed pivot point. The patent issued on May 29, 2001, and was assigned to Teleflex.

## C

Under the controlling cases from the Court of Appeals for the Federal Circuit, however, the District Court was . . . required also to apply the TSM test. The District Court held KSR had satisfied the test. It reasoned (1) the state of the industry would lead inevitably to combinations of electronic sensors and adjustable pedals, (2) Rixon provided the basis for these developments, and (3) Smith taught a solution to the wire-chafing problems in Rixon, namely, locating the sensor on the fixed structure of the pedal. This could lead to the combination of Asano, or a pedal like it, with a pedal position sensor.

The conclusion that the Engelgau design was obvious was supported, in the District Court's view, by the PTO's rejection of the broader version of claim 4. Had Engelgau included Asano in his patent application, it reasoned, the PTO would have found claim 4 to be an obvious combination of Asano and Smith, as it had found the broader version an obvious combination of Redding and Smith. . . . The District Court granted summary judgment for KSR.

With principal reliance on the TSM test, the Court of Appeals reversed. It ruled the District Court had not been strict enough in applying the test, having failed to make "findings as to the specific understanding or principle within the knowledge of a skilled artisan that would have motivated one with no knowledge of the invention to attach an electronic control to the support bracket of the Asano assembly." The Court of Appeals held that the District Court was incorrect that the nature of the problem to be solved satisfied this requirement because unless the "prior art references addressed the precise problem that the patentee was trying to solve," the problem would not motivate an inventor to look at those references.

Here, the Court of Appeals found, the Asano pedal was designed to solve the "constant ratio problem" — that is, to ensure that the force required to depress the pedal is the same no matter how the pedal is adjusted—whereas Engelgau sought to provide a simpler, smaller, cheaper adjustable electronic pedal. As for Rixon, the court explained, that pedal suffered from the problem of wire chafing but was not designed to solve it. In the court's view Rixon did not teach anything helpful to Engelgau's purpose. Smith, in turn, did not relate to adjustable pedals and did not "necessarily go to the issue of motivation to attach the electronic control on the support bracket of the pedal assembly." When the patents were interpreted in this way, the Court of Appeals held, they would not have led a person of ordinary skill to put a sensor on the sort of pedal described in Asano.

That it might have been obvious to try the combination of Asano and a sensor was likewise irrelevant, in the court's view, because "'obvious to try' has long been held not to constitute obviousness."

The Court of Appeals also faulted the District Court's consideration of the PTO's rejection of the broader version of claim 4. The District Court's role, the Court of Appeals explained, was not to speculate regarding what the PTO might have done had the Engelgau patent mentioned Asano. Rather, the court held, the District Court was obliged first to presume that the issued patent was valid and then to render its own independent judgment of obviousness based on a review of the prior art. The fact that the PTO had rejected the broader version of claim 4, the Court of Appeals said, had no place in that analysis.

## II

## A

We begin by rejecting the rigid approach of the Court of Appeals. Throughout this Court's engagement with the question of obviousness, our cases have set forth an expansive and flexible approach inconsistent with the way the Court of Appeals applied its TSM test here. To be sure, *Graham* recognized the need for "uniformity and definiteness." Yet the principles laid down in *Graham* reaffirmed the "functional approach" of *Hotchkiss*. To this end, *Graham* set forth a broad inquiry and invited courts, where appropriate, to look at any secondary considerations that would prove instructive.

Neither the enactment of § 103 nor the analysis in *Graham* disturbed this Court's earlier instructions concerning the need for caution in granting a patent based on the combination of elements found in the prior art. For over a half century, the Court has held that a "patent for a combination which only unites old elements with no change in their respective functions obviously withdraws what already is known into the field of its monopoly and diminishes the resources available to skillful men." *Great Atlantic & Pacific Tea Co. v. Supermarket Equipment Corp.* . . . The combination of familiar elements according to known methods is likely to be obvious when it does no more than yield predictable results. Three cases decided after *Graham* illustrate the application of this doctrine.

In *United States v. Adams*, a companion case to *Graham*, the Court considered the obviousness of a "wet battery" that varied from prior designs in two ways: It contained water, rather than the acids conventionally employed in storage batteries; and its electrodes were magnesium and cuprous chloride, rather than zinc and silver chloride. The Court recognized that when a patent claims a structure already known in the prior art that is altered by the mere substitution of one element for another known in the field, the combination must do more than yield a predictable result. It nevertheless rejected the Government's claim that Adams' battery was obvious. The Court relied upon the

## NONOBVIOUSNESS

corollary principle that when the prior art teaches away from combining certain known elements, discovery of a successful means of combining them is more likely to be nonobvious. When Adams designed his battery, the prior art warned that risks were involved in using the types of electrodes he employed. The fact that the elements worked together in an unexpected and fruitful manner supported the conclusion that Adams' design was not obvious to those skilled in the art.

In *Anderson's-Black Rock, Inc. v. Pavement Salvage Co.*, 396 U.S. 57 (1969), the Court elaborated on this approach. The subject matter of the patent before the Court was a device combining two pre-existing elements: a radiant-heat burner and a paving machine. The device, the Court concluded, did not create some new synergy: The radiant-heat burner functioned just as a burner was expected to function; and the paving machine did the same. The two in combination did no more than they would in separate, sequential operation. In those circumstances, "while the combination of old elements performed a useful function, it added nothing to the nature and quality of the radiant-heat burner already patented," and the patent failed under § 103.

Finally, in *Sakraida v. Ag Pro, Inc.*, 425 U.S. 273 (1976), the Court derived from the precedents the conclusion that when a patent "simply arranges old elements with each performing the same function it had been known to perform" and yields no more than one would expect from such an arrangement, the combination is obvious.

The principles underlying these cases are instructive when the question is whether a patent claiming the combination of elements of prior art is obvious. When a work is available in one field of endeavor, design incentives and other market forces can prompt variations of it, either in the same field or a different one. If a person of ordinary skill can implement a predictable variation, § 103 likely bars its patentability. For the same reason, if a technique has been used to improve one device, and a person of ordinary skill in the art would recognize that it would improve similar devices in the same way, using the technique is obvious unless its actual application is beyond his or her skill. A court must ask whether the improvement is more than the predictable use of prior art elements according to their established functions.

Following these principles may be more difficult in other cases than it is here because the claimed subject matter may involve more than the simple substitution of one known element for another or the mere application of a known technique to a piece of prior art ready for the improvement. Often, it will be necessary for a court to look to interrelated teachings of multiple patents; the effects of demands known to the design community or present in the marketplace; and the background knowledge possessed by a person having ordinary skill in the art, all in order to determine whether there was an apparent reason to combine the known elements in the fashion claimed by the patent at issue. To facilitate review, this analysis should be made explicit. As our precedents make clear, however, the

## CHAPTER 7

analysis need not seek out precise teachings directed to the specific subject matter of the challenged claim, for a court can take account of the inferences and creative steps that a person of ordinary skill in the art would employ.

### B

When it first established the requirement of demonstrating a teaching, suggestion, or motivation to combine known elements in order to show that the combination is obvious, the Court of Customs and Patent Appeals captured a helpful insight. As is clear from cases such as *Adams*, a patent composed of several elements is not proved obvious merely by demonstrating that each of its elements was, independently, known in the prior art. Although common sense directs one to look with care at a patent application that claims as innovation the combination of two known devices according to their established functions, it can be important to identify a reason that would have prompted a person of ordinary skill in the relevant field to combine the elements in the way the claimed new invention does. This is so because inventions in most, if not all, instances rely upon building blocks long since uncovered, and claimed discoveries almost of necessity will be combinations of what, in some sense, is already known.

Helpful insights, however, need not become rigid and mandatory formulas; and when it is so applied, the TSM test is incompatible with our precedents. The obviousness analysis cannot be confined by a formalistic conception of the words teaching, suggestion, and motivation, or by overemphasis on the importance of published articles and the explicit content of issued patents. The diversity of inventive pursuits and of modern technology counsels against limiting the analysis in this way. In many fields it may be that there is little discussion of obvious techniques or combinations, and it often may be the case that market demand, rather than scientific literature, will drive design trends. Granting patent protection to advances that would occur in the ordinary course without real innovation retards progress and may, in the case of patents combining previously known elements, deprive prior inventions of their value or utility.

### C

The flaws in the analysis of the Court of Appeals relate for the most part to the court's narrow conception of the obviousness inquiry reflected in its application of the TSM test. In determining whether the subject matter of a patent claim is obvious, neither the particular motivation nor the avowed purpose of the patentee controls. What matters is the objective reach of the claim. If the claim extends to what is obvious, it is invalid under § 103. One of the ways in which a patent's subject matter can be proved obvious is by noting that there existed at the time of invention a known problem for which there was an obvious solution encompassed by the patent's claims.

## NONOBVIOUSNESS

The first error of the Court of Appeals in this case was to foreclose this reasoning by holding that courts and patent examiners should look only to the problem the patentee was trying to solve. The Court of Appeals failed to recognize that the problem motivating the patentee may be only one of many addressed by the patent's subject matter. The question is not whether the combination was obvious to the patentee but whether the combination was obvious to a person with ordinary skill in the art. Under the correct analysis, any need or problem known in the field of endeavor at the time of invention and addressed by the patent can provide a reason for combining the elements in the manner claimed.

The second error of the Court of Appeals lay in its assumption that a person of ordinary skill attempting to solve a problem will be led only to those elements of prior art designed to solve the same problem. The primary purpose of Asano was solving the constant ratio problem; so, the court concluded, an inventor considering how to put a sensor on an adjustable pedal would have no reason to consider putting it on the Asano pedal. Common sense teaches, however, that familiar items may have obvious uses beyond their primary purposes, and in many cases a person of ordinary skill will be able to fit the teachings of multiple patents together like pieces of a puzzle. Regardless of Asano's primary purpose, the design provided an obvious example of an adjustable pedal with a fixed pivot point; and the prior art was replete with patents indicating that a fixed pivot point was an ideal mount for a sensor. The idea that a designer hoping to make an adjustable electronic pedal would ignore Asano because Asano was designed to solve the constant ratio problem makes little sense. A person of ordinary skill is also a person of ordinary creativity, not an automaton.

The same constricted analysis led the Court of Appeals to conclude, in error, that a patent claim cannot be proved obvious merely by showing that the combination of elements was "obvious to try." When there is a design need or market pressure to solve a problem and there are a finite number of identified, predictable solutions, a person of ordinary skill has good reason to pursue the known options within his or her technical grasp. If this leads to the anticipated success, it is likely the product not of innovation but of ordinary skill and common sense. In that instance the fact that a combination was obvious to try might show that it was obvious under § 103.

The Court of Appeals, finally, drew the wrong conclusion from the risk of courts and patent examiners falling prey to hindsight bias. A factfinder should be aware, of course, of the distortion caused by hindsight bias and must be cautious of arguments reliant upon ex post reasoning. Rigid preventative rules that deny factfinders recourse to common sense, however, are neither necessary under our case law nor consistent with it.

...

## III

When we apply the standards we have explained to the instant facts, claim 4 must be found obvious. We agree with and adopt the District Court's recitation of the relevant prior art and its determination of the level of ordinary skill in the field. . . . A person having ordinary skill in the art could have combined Asano with a pedal position sensor in a fashion encompassed by claim 4, and would have seen the benefits of doing so.

## B

The District Court was correct to conclude that, as of the time Engelgau designed the subject matter in claim 4, it was obvious to a person of ordinary skill to combine Asano with a pivot-mounted pedal position sensor. There then existed a marketplace that created a strong incentive to convert mechanical pedals to electronic pedals, and the prior art taught a number of methods for achieving this advance. The Court of Appeals considered the issue too narrowly by, in effect, asking whether a pedal designer writing on a blank slate would have chosen both Asano and a modular sensor similar to the ones used in the Chevrolet truckline and disclosed in the '068 patent. The District Court employed this narrow inquiry as well, though it reached the correct result nevertheless. The proper question to have asked was whether a pedal designer of ordinary skill, facing the wide range of needs created by developments in the field of endeavor, would have seen a benefit to upgrading Asano with a sensor.

In automotive design, as in many other fields, the interaction of multiple components means that changing one component often requires the others to be modified as well. Technological developments made it clear that engines using computer-controlled throttles would become standard. As a result, designers might have decided to design new pedals from scratch; but they also would have had reason to make pre-existing pedals work with the new engines. Indeed, upgrading its own pre-existing model led KSR to design the pedal now accused of infringing the Engelgau patent.

For a designer starting with Asano, the question was where to attach the sensor. The consequent legal question, then, is whether a pedal designer of ordinary skill starting with Asano would have found it obvious to put the sensor on a fixed pivot point. The prior art discussed above leads us to the conclusion that attaching the sensor where both KSR and Engelgau put it would have been obvious to a person of ordinary skill.

The '936 patent taught the utility of putting the sensor on the pedal device, not in the engine. Smith, in turn, explained to put the sensor not on the pedal's footpad but instead on its support structure. And from the known wire-chafing problems of Rixon, and Smith's teaching that "the pedal assemblies must not precipitate any motion in the connecting wires," the designer would know to place the sensor on a nonmoving part of the pedal structure. The most obvious nonmoving point on the structure from which a



sensor can easily detect the pedal's position is a pivot point. The designer, accordingly, would follow Smith in mounting the sensor on a pivot, thereby designing an adjustable electronic pedal covered by claim 4.

Just as it was possible to begin with the objective to upgrade Asano to work with a computer-controlled throttle, so too was it possible to take an adjustable electronic pedal like Rixon and seek an improvement that would avoid the wire-chafing problem. Following similar steps to those just explained, a designer would learn from Smith to avoid sensor movement and would come, thereby, to Asano because Asano disclosed an adjustable pedal with a fixed pivot.

...

Like the District Court, finally, we conclude Teleflex has shown no secondary factors to dislodge the determination that claim 4 is obvious. Proper application of *Graham* and our other precedents to these facts therefore leads to the conclusion that claim 4 encompassed obvious subject matter. As a result, the claim fails to meet the requirement of § 103.

...

We build and create by bringing to the tangible and palpable reality around us new works based on instinct, simple logic, ordinary inferences, extraordinary ideas, and sometimes even genius. These advances, once part of our shared knowledge, define a new threshold from which innovation starts once more. And as progress beginning from higher levels of achievement is expected in the normal course, the results of ordinary innovation are not the subject of exclusive rights under the patent laws. Were it otherwise patents might stifle, rather than promote, the progress of useful arts. See U.S. Const., Art. I, § 8, cl. 8. These premises led to the bar on patents claiming obvious subject matter established in *Hotchkiss* and codified in § 103. Application of the bar must not be confined within a test or formulation too constrained to serve its purpose.

KSR provided convincing evidence that mounting a modular sensor on a fixed pivot point of the Asano pedal was a design step well within the grasp of a person of ordinary skill in the relevant art. Its arguments, and the record, demonstrate that claim 4 of the Engelgau patent is obvious. In rejecting the District Court's rulings, the Court of Appeals analyzed the issue in a narrow, rigid manner inconsistent with § 103 and our precedents. The judgment of the Court of Appeals is reversed, and the case is remanded for further proceedings consistent with this opinion. It is so ordered.

## Context & Application

1. Is the TSM test dead after *KSR*? Or only mostly dead? Why do you think the Federal Circuit developed the TSM test in the first place?

2. What is the “obvious to try” test? Why did the Federal Circuit reject it? What is the status of “obvious to try” after *KSR*?

3. In *KSR*, the Supreme Court says that factfinders must be able to use “common sense” in analyzing whether a claimed invention is obvious, and that “[a] person of ordinary skill is also a person of ordinary creativity, not an automaton.” What evidence can or should courts and the USPTO use to determine what constitutes ordinary creativity? To demonstrate that something is a matter of common sense?

4. For one example of how common sense might come into play in the § 103 analysis, consider this recent concurrence:

[W]hen the record shows a finite number of identified, predictable solutions to a design need that existed at the relevant time, which a person of ordinary skill in the art had a good reason to pursue, common sense can supply a motivation to combine. . . . [W]e [have] explained that a person of ordinary skill provided with a simple design choice to address a problem is presumed to have a good reason to pursue the known options within his or her technical grasp.

Obviousness is particularly apparent where the alleged novelty of the patent is not related to the differences between a finite number of identified, predictable solutions, identified in the prior art. Because the use of a look-up table and an ordered list was only one of a number of finite, predictable solutions, it would have been obvious to use a technique that was known to one of ordinary skill in the art. The Board erred by requiring FanDuel to supply a specific motivation to use a look-up table and ordered list in this particular context when that choice would have been a simple alternative design choice to a skilled artisan.

*Fanduel, Inc. v. Interactive Games LLC*, 966 F.3d 1334, 1346 (Fed. Cir. 2020) (Dyk, J., concurring in part and dissenting in part) (internal quotation marks omitted). Is this a good approach for addressing issues of common sense? Can you imagine problems for which making “a simple alternative design choice” might *not* result in an obvious solution?

*Transocean Offshore Deepwater Drilling, Inc. v. Maersk Drilling USA*  
699 F.3d 1340 (Fed. Cir. 2012)

MOORE, Circuit Judge.

Transocean Offshore Deepwater Drilling, Inc. appeals from the decision . . . granting judgment as a matter of law that . . . the asserted claims of U.S. Patent Nos. 6,047,781 ('781 patent), 6,085,851 ('851 patent), and 6,068,069 ('069 patent) are invalid for obviousness . . . . For the reasons set forth below, we reverse.

*Background*

The patents-in-suit, which share a common specification, are directed to an improved apparatus for conducting offshore drilling. We described the process of offshore drilling in detail in our opinion resolving the first appeal in this case, and repeat this description only to the extent necessary for this appeal. See *Transocean Offshore Deepwater Drilling, Inc. v. Maersk Contractors USA, Inc.*, 617 F.3d 1296, 1301 (Fed. Cir. 2010) (*Transocean I*).

The process of creating a borehole in the seafloor requires lowering several components to the seabed from a derrick on the ocean surface. These include the drill bit, the casings that form the wall of the borehole, and a device called a blowout preventer. Id. The components are lowered on a "drill string," which is made up of a series of pipe sections ("tubular members"). The drill string is assembled on the derrick, with pipe sections being added to the top of the string one by one to extend it to the seafloor.

The drill bit is the first component to be lowered. Once enough pipe sections have been added to the drill string to lower the drill bit to the seabed, a "top drive" on the derrick rotates the drill string to create a borehole. Additional pipe sections are added to the drill string as the bit drills deeper into the seabed. Once the drill creates a portion of the borehole, the derrick retracts the drill bit to the surface, removing each section of the drill string piece by piece. A section of casing is then lowered into the borehole, with the drill string again being constructed on the derrick, one pipe section at a time. The next step is lowering the blowout preventer to the seabed, again with the drill string being assembled piece by piece. The process of drilling and lowering casing into the borehole then repeats until the hole is the desired depth. Each time a component is lowered to the seafloor, a drill string must be assembled and disassembled.

Conventional drilling rigs use a derrick with a single drawworks and thus can only raise or lower one component at a time. Transocean sought to improve the efficiency of this time-consuming process using the "dual-activity" drilling apparatus disclosed in the patents-in-suit. The patents recite a derrick with both a main and an auxiliary advancing station, each of which can separately assemble drill strings and lower components to the seafloor. Each advancing station has a drawworks for raising and lowering the drill string

and a top drive for rotating the drill string. While the auxiliary advancing station drills and cases the first portion of the borehole, the main advancing station lowers the blowout preventer. The auxiliary advancing station then retracts the drill string and supports the main advancing station by preparing lengths of drill string in advance. Transocean's patents disclose a pipe handling system, also called a transfer assembly, which allows the transfer of casing, drill string, and other components between the two advancing stations and from the advancing stations to storage areas.

...

... [A] jury found that Maersk failed to prove that the asserted claims would have been obvious. . . . The jury made specific findings that the prior art failed to disclose every element of the asserted claims and that each of seven objective factors indicated nonobviousness. . . . The district court, however, granted Maersk's motions for judgment as a matter of law (JMOL) that the asserted claims are invalid as obvious. . . .

#### *Discussion*

We review a district court's grant or denial of JMOL under the law of the regional circuit. The Fifth Circuit reviews the grant or denial of JMOL de novo. JMOL is appropriate only if "the facts and inferences point so strongly and overwhelmingly in favor of one party that the Court believes that reasonable men could not arrive at a contrary verdict." We have interpreted the Fifth Circuit's JMOL standard to mean that the jury's determination must be supported by substantial evidence. Substantial evidence is "such evidence as a reasonable mind might accept as adequate to support a conclusion." In determining whether a jury's finding is supported by substantial evidence, "we must presume that the jury resolved all factual disputes in favor of the prevailing party."

#### I

A patent is invalid as obvious "if the differences between the subject matter sought to be patented and the prior art are such that the subject matter as a whole would have been obvious at the time the invention was made to a person having ordinary skill in the art to which said subject matter pertains." 35 U.S.C. § 103(a). Obviousness is a question of law with several underlying factual inquiries: (1) the scope and content of the prior art; (2) the differences between the prior art and the claims at issue; (3) the level of ordinary skill in the field of the invention; and (4) objective considerations such as commercial success, long felt but unsolved need, and the failure of others. *Graham v. John Deere Co. of Kan. City*, 383 U.S. 1, 17–18 (1966); *see also KSR Int'l Co. v. Teleflex, Inc.*, 550 U.S. 398, 406 (2007). Patent invalidity must be established by clear and convincing evidence.

## NONOBVIOUSNESS

### A

In *Transocean I*, we expressly held that the Horn and Lund references teach every limitation of the asserted claims. Claim 17 of the '069 patent, which is exemplary of the claims at issue on appeal, recites:

A multi-activity drilling assembly operable to be supported from a position above the surface of a body of water for conducting drilling operations to the seabed and into the bed of the body of water, said multi-activity drilling assembly including:

a drilling superstructure operable to be mounted upon a drilling deck for simultaneously supporting drilling operations for a well and operations auxiliary to drilling operations for the well;

a first tubular advancing station connected to said drilling superstructure for advancing tubular members to the seabed and into the bed of body of water;

a second tubular advancing station connected to said drilling superstructure for advancing tubular members simultaneously with said first tubular advancing station to the seabed and into the body of water to the seabed; and

an assembly positioned adjacent to said first and second tubular advancing stations operable to transfer tubular assemblies between said first tubular advancing station and said second tubular advancing station to facilitate simultaneous drilling operations auxiliary to said drilling operations, wherein drilling activity can be conducted for the well from said drilling superstructure by said first or second tubular advancing stations and auxiliary drilling activity can be simultaneously conducted for the well from said drilling superstructure by the other of said first or second tubular advancing stations.

As we explained in *Transocean I*, Horn discloses a drilling rig with a single derrick that supports two advancing stations, each of which can advance tubular members to the seabed. Although Horn fails to disclose a pipe transfer assembly that can move tubular members between the two advancing stations, Lund teaches this limitation. We also explained that Horn provides a motivation to combine the teachings of these two references to arrive at the claimed invention, stating that “of other obvious advantages, there is the possibility of concentrating common auxiliary equipment.” We concluded that these references “present a prima facie case of obviousness.” *Transocean I* thus establishes as law of the case that Horn and Lund teach every limitation of the asserted claims and provide a motivation to combine their respective teachings. It was thus erroneous for the district court to permit the jury to engage in fact finding regarding whether Lund and Horn disclose all of the claim elements.

The establishment of a prima facie case, however, is not a conclusion on the ultimate issue of obviousness. . . . The prima facie inquiry is based on the first three *Graham* factors—the scope and content of the prior art, the differences between the prior art and the claims, and the level of ordinary skill in the art—which the Supreme Court described as the background against which the obviousness or nonobviousness of the subject matter is determined. A party is also free to introduce evidence relevant to the fourth *Graham* factor, objective evidence of nonobviousness, which may be sufficient to disprove or rebut a prima facie case of obviousness.

As we have repeatedly held, “evidence rising out of the so-called ‘secondary considerations’ must always when present be considered en route to a determination of obviousness.” *Stratoflex, Inc. v. Aeroquip Corp.*, 713 F.2d 1530, 1538 (Fed. Cir. 1983). Objective evidence of nonobviousness is an important component of the obviousness inquiry because “evidence of secondary considerations may often be the most probative and cogent evidence in the record. It may often establish that an invention appearing to have been obvious in light of the prior art was not.” This objective evidence must be “considered as part of all the evidence, not just when the decisionmaker remains in doubt after reviewing the art.” Thus, in order to determine obviousness, the decisionmaker must be able to consider all four *Graham* factors. Although we held in *Transocean I* that Maersk presented a prima facie case of obviousness, it was not error to allow the jury to consider the strength of that prima facie case in making the ultimate determination of obviousness. When the ultimate question of obviousness is put to the jury, the jury must be able to review all of the evidence of obviousness. Hence it was not error for the court to allow the jury to weigh the strength of the prima facie case together with the objective evidence in order to reach a conclusion on the ultimate question of obviousness.

## B

Although we held in *Transocean I* that Horn and Lund establish a prima facie case that the asserted claims would have been obvious, we reversed the district court's grant of summary judgment because the court failed to consider *Transocean's* objective evidence of nonobviousness. On the summary judgment record, *Transocean* presented evidence of industry praise, commercial success, industry skepticism, and copying. We stated that, “if all of the factual disputes regarding the objective evidence resolve in favor of *Transocean*, it has presented a strong basis for rebutting the prima facie case” of obviousness.

On remand, the jury made express findings on seven types of objective evidence of nonobviousness: commercial success, industry praise, unexpected results, copying, industry skepticism, licensing, and long-felt but unsolved need. The jury found that each of these considerations supported the nonobviousness of *Transocean's* claims. In granting Maersk's motion for JMOL of obviousness, however, the district court concluded that the record evidence fails to support these findings. We disagree. As detailed below,

## NONOBVIOUSNESS

Transocean presented substantial evidence from which a reasonable jury could find that each of the seven objective factors supports the nonobviousness of Transocean's claims.

1

The district court rejected the jury's finding that commercial success supports nonobviousness. The court found that sales of Transocean's dual-activity rigs are "due primarily to various litigations," and thus they "are not a result of a free market." The court also found that, at the time Transocean's patents issued, the drilling industry was "fully aware of the possibilities of a dual string rig as prior art" and that Transocean's patent application on this technology had been rejected in Europe as lacking inventiveness. Maersk contends that Transocean failed to tie its commercial success evidence to the claimed combination of two advancing stations with a pipe transfer assembly. Maersk also argues that unclaimed features of Transocean's rigs, such as increased size and capacity, are responsible for any commercial success.

As an initial matter, the district court erred by considering proceedings before the European Patent Office in its commercial success analysis. Transocean needed to show both commercial success and that a nexus exists between that success and the merits of the claimed invention. It is irrelevant to the commercial success analysis, however, that a foreign patent office rejected Transocean's patent application on the dual-activity technology. The district court's analysis seems to have been clouded by its view that the asserted claims would have been obvious over the prior art. This is precisely the sort of hindsight bias that evaluation of objective evidence is intended to avoid. See, e.g., *Graham*.

Transocean presented sufficient evidence of both commercial success and nexus to the features of the claimed invention. It showed, for example, that its dual-activity drilling rigs commanded a market premium over single-activity rigs. Transocean points to two contracts it signed on the same day with Anadarko Petroleum Corporation, one for a dual-activity drilling rig and one for a single-activity rig. Transocean charged a roughly 12% premium for the dual-activity rig. Transocean introduced other contracts that provided for reduced daily rates if the dual-activity feature on the rig was not available. Transocean's damages expert, Mr. Bratic, testified that the average reduction in this circumstance is 10%.

Transocean also presented evidence that some customers expressly require dual-activity rigs. For example, a Maersk employee testified at trial that Maersk added dual-activity to its new drilling rig design based on market surveys showing customer demand for this feature. Testimony by Maersk's own employee shows that customers request the dual-activity feature specifically based on the efficiency gains it provides by "involving two well centers in drilling the wells." The Maersk employee stated that "many operators do require dual activity ... for flexibility and for improved efficiency." Maersk sought to

“incorporate the same efficiency improvement features as used by our competition” by incorporating Transocean’s “dual-activity” technology, which Maersk distinguished from the “dual drilling” disclosed in the prior art. Transocean also offered testimony that dual-activity rigs account for an increasing percentage of the rigs sold and that they have become the industry standard.

From this evidence, a reasonable jury could conclude that Transocean’s dual-activity rigs have been a commercial success and that this success has a nexus to the features claimed in the patents. We thus conclude that substantial evidence supports the jury’s finding that commercial success weighs in favor of nonobviousness.

2

The jury found that Transocean’s dual-activity rigs received industry praise and achieved unexpectedly superior results, and that these factors supported nonobviousness. The district court rejected the jury’s findings, reasoning that Transocean presented no statistical data to support these conclusions.

Maersk contends that any praise or unexpected and superior results are due to unclaimed features of Transocean’s rig or elements from the prior art. Maersk argues that Transocean’s evidence of praise for dual-activity rigs is no different from praise for the dual-drilling technology taught in the prior art. With dual-activity rigs, only one of two advancing stations actually drills, whereas dual-drilling involves using both advancing stations to simultaneously drill two wells.

We conclude that substantial evidence supports the jury’s findings on industry praise and unexpected results. Transocean presented numerous documents showing industry praise for the unexpected increase in drilling efficiency made possible using Transocean’s patented dual-activity technology. . . .

Transocean also relied on an article in *Offshore Magazine* stating that multi-functionality (i.e., dual-activity) is “critical to [the] future.” This article specifically describes the features of Transocean’s dual-activity rigs: “a modified derrick and drill floor will allow for the makeup of drillstring and bottom hole assemblies separate from the drilling line where other functions such as casing installation may be underway.” The article states that the dual-activity operation will “allow for 20–40% faster tripping of drillstrings.” Transocean cites a second *Offshore Magazine* article, which praises the development of Transocean’s dual-activity drillship as one of the fifty key events or technologies in history that shaped the offshore drilling industry. The article notes the ability of the rig to reduce drilling time and costs by “conducting drilling operations simultaneously rather than sequentially via two full capability drilling rigs.” This is quite an impressive accolade, and the jury was free to credit it as such.



## NONOBVIOUSNESS

Additionally, one of the named inventors of the patents-in-suit, Mr. Scott, testified that industry members doubted whether the claimed dual-activity feature would increase drilling efficiency. BP, for example, doubted whether dual-activity would cut costs so it had its own efficiency engineers analyze one of Transocean's dual-activity drilling rigs. BP concluded that the rig could lead to even greater efficiency and cost savings than Transocean suggested.

This is substantial evidence from which the jury could reasonably conclude that Transocean's claimed dual-activity apparatus produced unexpected efficiency gains and that this benefit garnered praise in the drilling industry. Transocean's evidence also links both the industry praise and the unexpected efficiency gains directly to the claimed dual-activity feature. The first Offshore Magazine article, for example, expressly attributes improved efficiency to a derrick that can prepare drill string separate from the drilling line, as described in Transocean's patents. This description clearly distinguishes Transocean's dual-activity technology from the dual-drilling technology described in the prior art. We conclude that the district court erred by determining that the jury lacked substantial evidence to find that industry praise and unexpected results support nonobviousness.

### 3

The district court failed to address the jury's finding that copying of the claimed invention supported nonobviousness. Maersk argues that Transocean's copying evidence is not tied to the novel features of its invention. We disagree. Transocean points to an internal Maersk document stating "we have to incorporate the same efficiency improvement features as used by our competition," and that "this feature is generally described as 'dual-activity.'" The Maersk document describes the features of dual-activity drilling, which it distinguishes from the "dual drilling" disclosed by Horn. The document states that Transocean's drillships are probably the "best known examples of dual activity vessels."

Transocean also presented evidence that Maersk was aware of Transocean's patents during the time Maersk was designing its accused rig. For example, a Maersk employee testified that he became aware of Transocean's patents "early on in the design development phase" of building the accused rig. Another Maersk employee stated that he became aware of the patents-in-suit during the design of the accused rig, but concluded that the patents were "not necessarily something that could be seen as protected" based on the prior art. A third Maersk employee stated that Maersk discussed Transocean's patents with customers in the United States and told them that Maersk did not infringe because the patents are invalid in view of the prior art.

This evidence shows that Maersk was aware of Transocean's patents and its drillships embodying the patents while Maersk designed its accused rig. The evidence also shows that Maersk decided to incorporate the claimed dual-activity feature anyway because it believed Transocean's patents were invalid over the prior art. Moreover, Maersk's internal document expressly ties its copying to the novel "dual-activity" features of Transocean's invention, which it distinguishes from the "dual drilling" taught in the prior art. This is substantial evidence that supports the jury's finding of copying.

4

The jury found that industry skepticism supports nonobviousness. Although the district court admitted that "it may be argued that a few in the market were skeptical," the court nonetheless concluded that Transocean presented insufficient evidence of industry skepticism to support the jury's finding. The court did not credit Transocean's evidence that people in the industry were skeptical of dual-activity rigs due to fears of "clashing," which occurs when the two drill strings collide with one another. The court reasoned that literature predating the filing of the patents-in-suit stated that concerns over clashing were unfounded. Maersk echoes this argument, pointing to a brochure by Horn dismissing concerns about clashing.

We conclude that the jury's fact finding was supported by substantial evidence. Transocean proffered testimony regarding skepticism by two named inventors of the patents-in-suit, Mr. Scott and Mr. Herrmann. They testified that even though they personally did not believe clashing was a concern, industry experts and Transocean's customers were skeptical of the claimed dual-activity feature due to fears of clashing. Mr. Herrmann recounted several occasions when industry experts stated that clashing would prevent dual-activity drilling from working and he stated that some people are still concerned with clashing even today. Mr. Scott recounted similar experiences.

This evidence is sufficient for a reasonable jury to conclude that members of the drilling industry were skeptical of Transocean's dual-activity rigs. Although Maersk presented evidence that it contends dispels concerns over clashing, Transocean's evidence indicates that skepticism persists nonetheless. A reasonable jury could accept Transocean's evidence of skepticism even if the evidence could also support a contrary conclusion. We thus conclude that the district court erred by rejecting the jury's finding that skepticism supports nonobviousness.

5

The jury found that Transocean established that its licenses to customers and competitors were due to the merits of the claimed invention and thus support nonobviousness. The district court did not directly address licensing, but found that Transocean's sales of its dual-activity technology were due primarily to litigation or threat

## NONOBVIOUSNESS

of litigation, and thus seems not to have credited Transocean's licensing evidence. Maersk similarly contends that Transocean's licenses do not support nonobviousness because they are attributable to the threat of litigation. Maersk also argues that Transocean's licenses are not tied to the asserted claims because they convey rights not only to the patents-in-suit, but also to foreign counterparts and other patents that are not part of this case.

Transocean counters that the royalties paid under the licenses exceed any litigation costs, and thus are an accurate reflection of the value of the claimed invention. For example, Transocean introduced evidence at trial of a royalty payment by Noble Drilling (U.S.) Inc. totaling nearly \$500,000 for one month of operations for one dual-activity rig. Transocean contends that large, sophisticated companies would not pay royalties exceeding the cost of litigation if the royalty did not reflect the value of the licensed technology. Transocean also offered testimony that at least three companies licensed its dual-activity drilling patents despite being under no threat of litigation. For example, Transocean's in-house counsel testified that both Shell and Pride Global, Limited, approached Transocean seeking to license its dual-activity technology

We conclude that Transocean presented sufficient evidence for the jury to find that Transocean's licensing supports nonobviousness. From Transocean's testimony regarding the value of the licenses relative to litigation costs and regarding licenses with companies under no apparent threat of litigation, a reasonable jury could have found that the licenses reflect the value of the claimed invention and are not solely attributable to litigation. As a result, the district court erred by holding that the jury lacked substantial evidence to support its finding regarding licensing.

6

The jury found that Transocean's invention provided a solution to a long-felt but unsolved need, and that this supports nonobviousness. The district court disagreed, finding that there was no long-felt but unresolved need because the prior art already disclosed dual string drilling technology. According to the court, no substantial demand existed for dual string drilling technology until deepwater drilling became more prevalent around the year 2000. On appeal, Maersk similarly argues that Transocean failed to present evidence linking any unmet need to the claimed features of the asserted claims.

We disagree. Transocean presented evidence at trial that its dual-activity technology satisfied a long-felt need for greater drilling efficiency. Transocean proffered testimony by two of the named inventors that the drilling industry had been operating in deepwater since the 1970s. One of Transocean's expert witnesses similarly testified that companies began to move towards deepwater drilling in the 1970s and that the drilling industry is always seeking greater efficiency from its rigs. The expert concluded that Transocean's

dual-activity technology thus fulfilled a long-felt but unsolved need for a drilling rig that could operate efficiently in deep water.

Two of the named inventors testified that, prior to the claimed invention, the industry had been searching for ways to increase efficiency by building sections of drill string “offline,” out of the path of the well conducting the drilling. These efforts were unsuccessful, however, and left an unsolved need for an efficient method of building the long drill strings needed for deepwater drilling without interrupting operations on the drilling well.

We conclude that substantial evidence supports the jury’s finding that long-felt but unsolved need supports nonobviousness. From this testimony, a reasonable jury could conclude that Transocean’s patents fulfilled a need in the drilling industry for a more efficient way to drill in deep water by allowing offline building of drill string and also including an auxiliary advancing station capable of lowering drilling components to the seabed. The district court erred by concluding that the jury lacked substantial evidence to support its finding on long-felt need.

## C

We held in *Transocean I* that Horn and Lund teach each limitation of the asserted claims, provide a motivation to combine their teachings, and thus make out a prima facie case of obviousness. In granting Maersk’s motion for JMOL of obviousness, the district court concluded that the objective evidence of nonobviousness was “insufficient, as a matter of law, to overcome Maersk’s prima facie case of obviousness.” We disagree.

...

Few cases present such extensive objective evidence of nonobviousness, and thus we have rarely held that objective evidence is sufficient to overcome a prima facie case of obviousness.

This, however, is precisely the sort of case where the objective evidence “establishes that an invention appearing to have been obvious in light of the prior art was not.” The jury found that seven distinct objective factors support nonobviousness and, as discussed above, these findings are all supported by substantial evidence. Weighing this objective evidence along with all the other evidence relevant to obviousness, we conclude that Maersk failed to prove by clear and convincing evidence that the asserted claims would have been obvious. We therefore reverse the district court’s grant of JMOL of obviousness.

...

## Context & Application

1. In *Transocean*, as in many other cases, the Federal Circuit refers to what the Supreme Court calls “secondary” considerations as “objective” evidence (or “indicia”) of nonobviousness. What does each court’s word choice tell us about the value they place upon this type of evidence?

2. The Federal Circuit also says that “evidence rising out of the so-called ‘secondary considerations’ must always when present be considered en route to a determination of obviousness,” relying on one of its own pre-KSR decisions. Is this consistent with KSR?

3. In *Transocean*, we also see that the Federal Circuit requires a patent owner to show a “nexus” between the secondary consideration and the claimed invention. Is this a good rule? Are you satisfied with the evidence that the patent owner used to prove such a nexus in this case? Which pieces of evidence in support of the secondary factors did you find more or less persuasive in this case?

4. Congress revised § 103 in 2012, as part of the AIA. It now says:

A patent for a claimed invention may not be obtained, notwithstanding that the claimed invention is not identically disclosed as set forth in section 102, if the differences between the claimed invention and the prior art are such that the claimed invention as a whole would have been obvious *before the effective filing date* of the claimed invention to a person having ordinary skill in the art to which the claimed invention pertains. Patentability shall not be negated by the manner in which the invention was made.

35 U.S.C. § 103 (2018) (emphasis added). You may have noticed that some of the prior decisions we’ve read refer to “§ 103(a)” but now, there are no subheadings. You can also see that the statute now refers to “the effective filing date” as opposed to “the time the invention was made.” Can you see why the latter change was necessary to comport with the other changes in the AIA? Do any of these changes affect the substance of the cases we’ve read so far?

*B/E Aerospace, Inc. v. C&D Zodiac, Inc.*  
962 F.3d 1373 (Fed. Cir. 2020)

REYNA, Circuit Judge.

B/E Aerospace, Inc. appeals a final written decision of the Patent Trial and Appeal Board that found certain claims of B/E’s aircraft lavatory-related patents obvious. . . . We conclude that the Board’s final determination of obviousness is correct. . . . On that basis we affirm the Board’s final written decision.

## CHAPTER 7

### *Background*

This appeal arises from an inter partes review (“IPR”) proceeding. Petitioner, C&D Zodiac, Inc. (“Zodiac”), challenged two patents owned by B/E Aerospace, Inc. (“B/E”), U.S. Patent No. 9,073,641 (“the ‘641 patent”) and U.S. Patent No. 9,440,742 (“the ‘742 patent”).

The technology involved in this appeal is simple. The challenged patents relate to space-saving technologies for aircraft enclosures such as lavatory enclosures, closets, and galleys. Each patent contains a two-page written description that teaches an enclosure with contoured walls designed to “reduce or eliminate the gaps and volumes of space required between lavatory enclosures and adjacent structures.” In other words, the patents are directed to space-saving modifications to the walls of aircraft enclosures; they are not directed to the structures contained within those walls.

The parties agree that, for purposes of this appeal, the challenged patents and claims are not materially different and that claim 1 of the ‘641 patent is representative of the challenged claims.

Claim 1 of the ‘641 patent provides:

1. An aircraft lavatory for a cabin of an aircraft of a type that includes a forward-facing passenger seat that includes an upwardly and aftwardly inclined seat back and an aft-extending seat support disposed below the seat back, the lavatory comprising:

a lavatory unit including a forward wall portion and defining an enclosed interior lavatory space, said forward wall portion configured to be disposed proximate to and aft of the passenger seat and including an exterior surface having a shape that is substantially not flat in a vertical plane; and

wherein said forward wall portion is shaped to substantially conform to the shape of the upwardly and aftwardly inclined seat back of the passenger seat, and includes a first recess configured to receive at least a portion of the upwardly and aftwardly inclined seat back of the passenger seat therein, and further includes a second recess configured to receive at least a portion of the aft-extending seat support therein when at least a portion of the upwardly and aftwardly inclined seat back of the passenger seat is received within the first recess.

This appeal focuses on the “first recess” and “second recess” limitations . . . .

A

In its petition, Zodiac defined the “Admitted Prior Art” as certain portions of the challenged patents, including Figure 1. As shown below, Figure 1 of the Admitted Prior

NONOBVIOUSNESS

Art discloses a flat, forward-facing lavatory wall immediately behind a passenger seat that has a rear seat leg extending toward the back of the plane (referred to as an “aft-extending seat support”).

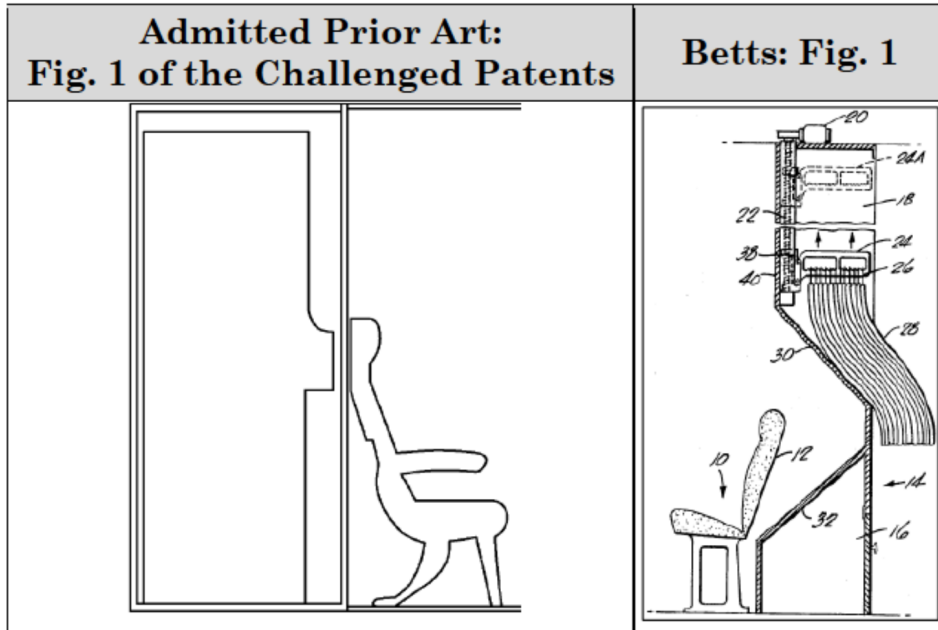

Betts discloses an airplane passenger seat with a tilting backrest. Behind the seat is a coat closet that has luggage space along the floor and an overhead coat compartment. Rather than a flat forward-facing wall, Betts discloses a contoured forward-facing wall to receive the tilted backrest. The “lower portion 30 of the coat compartment 18” of Betts “slants rearwardly to provide a space for seatback 12 to be tilted rearwardly.” The “top 32 of storage space 16 also slants rearwardly so as not to interfere with seatback 12 when tilted.”

B

In its final written decision, the Board concluded that Zodiac had proven that the challenged claims would have been “obvious over the Admitted Prior Art and Betts.” The Board determined that Betts’s contoured wall design met the “first recess” claim limitation. The Board also found that skilled artisans (airplane interior designers) would have been motivated to modify the flat forward-facing wall of the lavatory in the Admitted Prior Art with Betts’s contoured, forward-facing wall because skilled artisans were interested in adding space to airplane cabins, and Betts’s design added space by permitting the seat to be moved further aft.

## CHAPTER 7

The Board found that a skilled artisan would have found it “obvious to further modify the Admitted Prior Art/Betts combination to include the ‘second recess’ to receive passenger seat supports.” The Board used two separate approaches presented by Zodiac to reach that conclusion.

First, Zodiac argued that “the logic of using a recess to receive the seat back applies equally to using another recess to receive the aft extending seat support.” The Board found Zodiac’s arguments and testimony “credible and convincing.” The Board agreed with Zodiac that creating a recess in the wall to receive the seat support was an obvious solution to a known problem. The Board relied on the testimony of Zodiac’s expert, Mr. Anderson, who opined that the addition of a second recess “is nothing more than the application of a known technology (i.e., Betts) for its intended purpose with a predictable result (i.e., to position the seat as far back as possible). Mr. Anderson explained that a skilled artisan “would be motivated to modify an enclosure, such as a lavatory, to include a second recess to receive aft facing seat supports”; that this “modification is nothing more than the application of known technology for its intended purpose”; and that the “result of such a modification is predictable, allowing the seat to be positioned further aft in an aircraft.”

Second, the Board found that Zodiac “established a strong case of obviousness based on the Admitted Prior Art and Betts, coupled with common sense and the knowledge of a person of ordinary skill in the art. Relying on the testimony of Mr. Anderson, the Board found that recesses configured to receive seat supports “were known in the art” and that “it would have been a matter of common sense” to incorporate a second recess in the Admitted Prior Art/Betts combination.

### *Analysis*

B/E . . . argues that the Board’s obviousness determination is erroneous because it improperly incorporated a second recess limitation not disclosed in the prior art. . . .

### A

The Board found that Zodiac established a “strong case of obviousness.” We agree. There is no dispute that Betts’s contoured wall design meets the “first recess” claim limitation. Nor do the parties dispute that a skilled artisan would have been motivated to modify the Admitted Prior Art with Betts’s contoured wall because skilled artisans were interested in maximizing space in airplane cabins. Only the “second recess” limitation is at issue.

We find no error in the Board’s conclusion that—under both approaches it employed—“it would have been obvious to further modify the Admitted Prior Art/Betts combination to include the claimed ‘second recess’ to receive passenger seat supports.”



## NONOBVIOUSNESS

First, we affirm the Board's conclusion that the challenged claims would have been obvious because modifying the Admitted Prior Art/Betts combination to include a second recess was nothing more than the predictable application of known technology. The prior art yields a predictable result, the "second recess," because a person of skill in the art would have applied a variation of the first recess and would have seen the benefit of doing so. *KSR Int'l Co. v. Teleflex Inc.* The Board's conclusion is supported by substantial evidence, namely the expert testimony of Mr. Anderson, who opined:

A person of ordinary skill in the art would recognize that as a seat is moved further aft the seat support necessarily is also moved further aft. As the seat is moved aft the feet of the seat support may come into contact with the lower section of the wall. Creating one or more recesses to accommodate whatever portion(s) of the seat support that would contact the forward wall of the enclosure is the obvious solution to this known problem.

Second, we also affirm the Board's conclusion that the challenged claims would have been obvious because "it would have been a matter of common sense" to incorporate a second recess in the Admitted Prior Art/Betts combination. B/E asserts that the Board legally erred by relying on "an unsupported assertion of common sense" to "fill a hole in the evidence formed by a missing limitation in the prior art." B/E argues that the Board acted contrary to our precedent in *Arendi S.A.R.L. v. Apple Inc.*, 832 F.3d 1355, 1361 (Fed. Cir. 2016), because the Board failed to provide a "reasoned explanation and record evidence to support its position." We disagree.

In *KSR*, the Supreme Court opined that common sense serves a critical role in determining obviousness. As the Court explained, common sense teaches that familiar items may have obvious uses beyond their primary purposes, and in many cases a person of ordinary skill will be able to fit the teachings of multiple patents together like pieces of a puzzle. The Court held that "rules that deny factfinders recourse to common sense" are inconsistent with our case law.

After *KSR*, we recognized that courts must "consider common sense, common wisdom, and common knowledge in analyzing obviousness." *Arendi*. However, we cautioned that common sense cannot be used as a "wholesale substitute for reasoned analysis and evidentiary support, especially when dealing with a limitation missing from the prior art references specified." Likewise, in *Perfect Web Techs, Inc. v. InfoUSA, Inc.*, we reiterated that "common sense has long been recognized to inform the analysis of obviousness if explained with sufficient reasoning." 587 F.3d 1324, 1328 (Fed. Cir. 2009).

Here, the Board's invocation of common sense was properly accompanied by reasoned analysis and evidentiary support. The Board dedicated more than eight pages of analysis to the "second recess" limitation and relied on Mr. Anderson's detailed expert

testimony. The Board noted Mr. Anderson's opinion that a "person of ordinary skill in the art would recognize that as a seat is moved further aft the seat support necessarily is also moved further aft." The Board also cited Mr. Anderson's opinion that "lower recesses were a well-known solution to provide space for seat supports where a recess for a seat back in the forward wall of the enclosure unit permitted the seat to be located further aft."

In *Perfect Web*, we affirmed a district court's invocation of common sense to supply a missing claim limitation. The missing limitation was step D of steps A-D of a method for delivering a predetermined quantity of emails. The record showed that the technology was simple and that "step (D) merely involves repeating earlier steps" until success is achieved. We also determined that the district court "adequately explained its invocation of common sense."

Here, just like in *Perfect Web*, the evidence shows that the technology of the claimed invention is simple. The patents relate to contoured walls that "reduce or eliminate the gaps and volumes of space required between lavatory enclosures and adjacent structures." The missing claim limitation (the "second recess") involves repetition of an existing element (the "first recess") until success is achieved.

We find no error in the Board's conclusion that a skilled artisan would have used common sense to incorporate a second recess in the Admitted Prior Art/Betts combination. We therefore affirm the Board's obviousness conclusion under both of its approaches.

### Context & Application

1. What do *B/E Aerospace* and the *Perfect Web* case cited therein teach us about the role of "common sense" post-KSR? What types of evidence has the Federal Circuit accepted on this issue?

2. How would *Transocean* and *B/E Aerospace* come out under the Federal Circuit's TSM test (at least, as that test was described in *KSR*)? In other words, how much did *KSR* really change the law?

3. Pharmaceuticals raise difficult questions with respect to § 103. You've already seen that hindsight bias is a concern in this area. But what if, as Rebecca Eisenberg has argued, chemical and pharmaceutical inventions often "appear less obvious in hindsight than they seemed *ex ante*"? See Rebecca S. Eisenberg, *Pharma's Nonobvious Problem*, 12 LEWIS & CLARK L. REV. 375, 378 (2008). These inventions also get analyzed differently. As Nicholson Price has explained:

To determine whether new chemicals—including pharmaceuticals—are obvious, the Federal Circuit has adopted a doctrine known as "lead compound analysis."

## NONOBVIOUSNESS

Essentially, if you want to show that a new chemical is obvious, you do two things: First, you find a close relative that is already known and second, you argue that the inventive step from that prior art compound to the new compound would be an obvious step for a PHOSITA to take. This is hard. Under the lead compound analysis framework, the prior art must essentially contain each step rather plainly to demonstrate prima facie obviousness. To show that a chemist of ordinary skill would select that chemical as a “lead compound” — “a compound in the prior art that would be most promising to modify” — structural similarity is necessary but insufficient; the field must know something about the putative lead compound, such as activity, solubility, or toxicity, that makes it a promising lead. Once a lead compound (or a small set of lead compounds) is identified, you must show that “prior art would have supplied one of ordinary skill in the art with a reason or motivation to modify a lead compound to make the claimed compound with a reasonable expectation of success.” This is a lot to ask of the prior art.

W. Nicholson Price II, *The Cost of Novelty*, 120 COLUM. L. REV. 769, 786–87 (2020). What do you think of this approach?

## 2. Other Factual Issues

*Graham* tells us that: “Under § 103, the scope and content of the prior art are to be determined; differences between the prior art and the claims at issue are to be ascertained; and the level of ordinary skill in the pertinent art resolved.” This section will explore in more detail what courts count as prior art for the purposes of § 103 and then will discuss how courts have determined the level of ordinary skill in the art.

*Circuit Check Inc. v. QXQ Inc.*  
795 F.3d 1331 (Fed. Cir. 2015)

MOORE, Circuit Judge.

Circuit Check, Inc. appeals from . . . judgment as a matter of law after a jury verdict that claims of U.S. Patent Nos. 7,592,796; 7,695,766; and 7,749,566 are invalid as obvious. We reverse the court’s judgment . . . and remand.

### *Background*

Manufacturers of circuit boards, which are used in various electronic devices, use circuit board testers to test circuit boards before the boards are integrated into finished products. Many testers require an interface plate, which is a plastic grid with holes that permit connections between the tester and the circuit board. In order to align circuit

boards during testing, it is advantageous to mark certain holes on the interface plate. Prior art methods of marking interface plates included placing Mylar masks on the surface of the interface plate, painting the surface of interface plates, and making shallow drill marks on interface plates.

The patents at issue claim systems and methods related to marking interface plates. Claim 1 of the '796 patent is representative:

1. An indicator interface plate configured to provide readily visible identification of predetermined holes, the plate comprising:

a surface including a plurality of holes having visually discernable markings to allow a user to visually determine which of said plurality of holes are to be populated, wherein a region of the plate said plurality of holes have a first predetermined indicia covering the surface surrounding said plurality of holes, the plate further comprising: a second removable indicia overlying said first predetermined indicia, said second indicia being different from said first predetermined indicia, wherein said second indicia is removed from areas of said plate adjacent each of said predetermined holes, said predetermined holes are visually identifiable to a user by the appearance of the first indicia.

Circuit Check sued QXQ, Inc., alleging that QXQ's interface plates infringed its patents. QXQ stipulated to infringement and the parties stipulated that three references describing interface plate marking techniques were prior art to the patents: the TTCI Specifications; the Plexus Specification; and the method depicted in Figure 1 of the '796 patent and described in its specification (collectively, the "stipulated prior art"). These documents disclosed several marking techniques, such as painting near the hole or drilling near the hole and painting over the drill mark. QXQ concedes in its briefing that the stipulated prior art does not disclose an interface plate comprising "a second removable indicia overlying said first predetermined indicia ... wherein said second indicia is removed from areas of said plate adjacent each of said predetermined holes."

At trial, QXQ argued that three additional references—rock carvings, engraved signage, and a machining technique known as Prussian Blue (collectively, the "disputed prior art")—disclose the limitation not present in the stipulated prior art and constitute analogous prior art. Circuit Check argued that the references were not analogous. With respect to rock carvings, in which a varnish is applied to rocks and then scrapped off to make designs, Circuit Check presented testimony that a skilled artisan at the time of the invention would not have considered rock carvings to have been reasonably pertinent to the marking problem. With respect to engraved signage, in which the top layer of a multi-layer product is removed to expose a bottom layer, Circuit Check presented testimony that engraved signage was not relevant to the problem solved by the patents. And with

## NONOBVIOUSNESS

respect to Prussian Blue, a machining technique whereby dye is applied to a workpiece and then removed by a scribe or drill, Circuit Check presented testimony that Prussian Blue could not be used to make the claimed invention and had no connection to the problem solved by the patents.

. . . The jury found the asserted claims not invalid for obviousness. . . .

After the jury verdict, QXQ filed a motion for judgment as a matter of law that the asserted claims are invalid as obvious. The district court granted QXQ's motion, acknowledging that QXQ's "obviousness argument is not premised on citing specific examples of prior art in the applicable field, nor does it rely on nuanced discussion about the level of ordinary skill in that particular field." It found that although there was no doubt that rock carvings "are not technically pertinent to the 'field' of circuit testers," and "witnesses credibly testified that Prussian Blue dye had not been used on alignment plates," "any layman" would have understood that interface plates could be marked using the techniques described in the disputed prior art. It further noted that "any vandal who has 'keyed' a car knows that stripping the paint with a key will result in the underlying metal color showing through." It found that none of the objective considerations affected its conclusion that the asserted claims would have been obvious. With respect to claims 5 and 11 of the '796 patent, the court determined that even though QXQ did not present evidence that the additional limitations of the claims would have been obvious, those additional limitations were too trivial to support nonobviousness. Circuit Check appeals. . . .

### *Discussion*

Judgment as a matter of law is permitted on an issue following jury trial if "the court finds that a reasonable jury would not have a legally sufficient evidentiary basis to find for the party on that issue." We review a district court's grant of judgment as a matter of law after a jury verdict *de novo*. Under Seventh Circuit law, we can overturn a jury's decision only if no rational jury could have come to the same conclusion. In reviewing a jury's obviousness verdict, "we first presume that the jury resolved the underlying factual disputes in favor of the verdict winner and leave those presumed findings undisturbed if they are supported by substantial evidence. Then we examine the legal conclusion *de novo* to see whether it is correct in light of the presumed jury fact findings."

A patent is invalid for obviousness "if the differences between the subject matter sought to be patented and the prior art are such that the subject matter as a whole would have been obvious at the time the invention was made to a person having ordinary skill in the art to which said subject matter pertains." 35 U.S.C. § 103(a) (2006). "Obviousness is a question of law based on underlying factual findings." The underlying factual inquiries include: (1) the scope and content of the prior art, (2) the differences between the

prior art and the claims at issue, (3) the level of ordinary skill in the art, and (4) any relevant objective considerations, such as commercial success, long felt but unsolved needs, and the failure of others. *Graham v. John Deere Co.*, 383 U.S. 1 (1966).

By finding the claims nonobvious, the jury presumably found that the disputed prior art is not analogous and therefore not within the scope of the prior art. Substantial evidence supports the jury's presumed finding. To be considered within the prior art for purposes of the obviousness analysis, a reference must be analogous. Whether a reference is analogous art is a question of fact. Prior art is analogous if it is from the same field of endeavor or if it is reasonably pertinent to the particular problem the inventor is trying to solve.

The jury was instructed that “the field of the invention is circuit board testers and test fixtures used in the manufacture of electronics.” The disputed prior art—rock carvings, engraved signage, and Prussian Blue—is not part of the field of circuit board testers and test figures. Therefore, the disputed prior art can be analogous only if it is reasonably pertinent to the particular problem solved by the inventor. Although “familiar items may have obvious uses beyond their primary purposes,” *KSR Int'l Co. v. Teleflex, Inc.*, 550 U.S. 398 (2007), a reference is only reasonably pertinent when it “logically would have commended itself to an inventor’s attention in considering his problem,” *In re Clay*, 966 F.2d 656, 659 (Fed. Cir. 1992). The jury heard testimony that a person of ordinary skill in the art would not have thought about rock carvings, engraved signage, or Prussian Blue in considering how to mark interface plates. The jury was entitled to weigh this testimony, find that an ordinarily skilled artisan would not find that the disputed prior art “logically would have commended itself to an inventor’s attention,” and thus find the disputed prior art not analogous. *See In re Clay*, 966 F.2d at 659.

Just because keying a car, for example, is within the common knowledge of humankind does not mean that keying a car is analogous art. An alleged infringer should not be able to transform all systems and methods within the common knowledge into analogous prior art simply by stating that anyone would have known of such a system or method. The question is not whether simple concepts such as rock carvings, engraved signage, or Prussian Blue dye are within the knowledge of lay people or even within the knowledge of a person of ordinary skill in the art. Rather, the question is whether an inventor would look to this particular art to solve the particular problem at hand. Here, Circuit Check put forward evidence that an inventor would not have considered the disputed prior art when trying to improve marking. It is not hard to arrive at that conclusion. Even though an inventor may be aware of rock carvings, it is not surprising that the inventor would not have looked to rock carvings to improve the process of painting small dots on interface plates for expensive circuit board testers. And, even though an inventor may work in an office with engraved signage, the inventor would not

## NONOBVIOUSNESS

necessarily have considered using the techniques disclosed in engraved signage to solve the problem of marking circuit board tester interface plates. Finally, even though an inventor in this case was aware of Prussian Blue, it is not surprising that one of skill in the art would not consider using a machining technique that employed removable dye on interface plates where such dye could fall into and interfere with the underlying electronics of the circuit board testers. Because the jury's presumed finding that the disputed references are not analogous is supported by substantial evidence, the only references within the scope of the prior art are the stipulated prior art.

...

Whatever doubts we have about these patents, the jury verdict was supported by substantial evidence. We therefore reverse the district court's grant of judgment as a matter of law and remand for further proceedings consistent with this opinion.

### Context & Application

1. In *Circuit Check*, the Federal Circuit tells us that just because something "is within the common knowledge of humankind" does not mean that thing qualifies as analogous art. Why not? Should it count?

2. How can a court know what "an inventor would look" at "to solve the particular problem at hand"? Also, is the Federal Circuit's focus on "the problem at hand" consistent with the Supreme Court's decision in *KSR*?

3. In *Circuit Check*, the Federal Circuit notes that on certain issues, it has to follow the regional circuit—in this case, the Seventh Circuit—case law. The Federal Circuit applies its own law to questions that are "unique to U.S. patent law." *Voda v. Cordis Corp.*, 476 F.3d 887, 892 (Fed. Cir. 2007). For other legal questions, it applies the law of the relevant regional circuit. *See id.* So, if an appeal involved claims for both patent and trademark infringement, which circuit's law should the Federal Circuit apply to each claim on appeal?

*Innovention Toys, LLC v. MGA Entertainment, Inc.*  
637 F.3d 1314 (Fed. Cir. 2011)

LOURIE, Circuit Judge.

MGA Entertainment, Inc.; Wal-Mart Stores, Inc.; and Toys "R" Us, Inc. (collectively, "MGA") appeal from the summary judgment decision . . . that the asserted claims of U.S. Patent 7,264,242 ("the '242 patent") were infringed and were not invalid for obviousness. Because the district court correctly found no genuine issues of material fact regarding

infringement based on its construction of the claim term “movable,” we affirm the court’s grant of summary judgment of literal infringement. The district court, however, erred in several of its factual findings underlying its nonobviousness determination. We therefore vacate the court’s grant of summary judgment of nonobviousness and remand.

### *Background*

#### I

Innovention Toys, LLC brought suit against MGA for infringement of the ’242 patent, which claims a chess-like, light-reflecting board game and methods of playing the same. The disclosed game includes a chess-styled playing surface, laser sources positioned to project light beams over the playing surface when “fired,” mirrored and non-mirrored playing pieces used to direct the lasers’ beams, and non-mirrored “key playing pieces” equivalent to the king pieces in chess. To play the game, players take turns either moving a playing piece to an unoccupied, adjacent square or rotating (reorienting) a piece within a square. After moving or rotating a piece, a player then fires his laser, and if the laser’s beam strikes the non-mirrored surface of a playing piece, that piece is eliminated from the game. To win the game, a player must direct his laser beam to strike, or illuminate, his opponent’s non-mirrored key playing piece, ending the game.

All the asserted claims . . . include a “key playing pieces” limitation in which the key pieces are “movable.” Claim 31 is representative:

A board game for two opposing players or teams of players comprising:

a game board, movable playing pieces having at least one mirrored surface, movable key playing pieces having no mirrored surfaces, and a laser source,

wherein alternate turns are taken to move playing pieces for the purpose of deflecting laser beams, so as to illuminate the key playing piece of the opponent.

MGA counterclaimed, denying infringement and alleging, *inter alia*, that the ’242 patent was invalid under 35 U.S.C. § 103. In making its obviousness argument, MGA relied on the combination of (1) two articles describing computer-based, chess-like strategy games, Laser Chess and Advanced Laser Chess (collectively, “the Laser Chess references”); and (2) U.S. Patent 5,145,182 (“the Swift patent”) describing a physical, chess-like, laser-based strategy game.

The Laser Chess game is described in an article entitled “Laser Chess™ First Prize \$5,000.00 Winner Atari ST Programming Contest,” published in the April 1987 edition of *Compute!*. Advanced Laser Chess is described in an article published in the Summer 1989 edition of *Compute!’s Amiga Resource*. Both articles disclose chess-like computer games with virtual lasers and mirrored and non-mirrored pieces, which are moved or rotated by players during alternating turns on a virtual, chess-like playing board. The goal of each



## NONOBVIOUSNESS

game is to manipulate one's laser beam using the various game pieces to eliminate the other player's non-mirrored king piece by striking it with the laser beam. In Laser Chess, a player's king piece may move squares during game play: "The king can capture any opposing piece by moving onto its square." Similarly, in Advanced Laser Chess "Kings possess the ability to capture other pieces by moving on top of them."

The Swift patent discloses a physical (rather than electronic) strategy game in which players take turns placing mirrored game pieces onto squares of a chess-styled game board. The players position the pieces so as to direct their laser's beam towards the opposing player's scoring module and away from their own. A player scores when his laser beam, having been deflected around the game board, strikes his opponent's scoring module. The scoring modules are mounted to the frame of the game board, and thus are not physically capable of movement on the game board.

MGA's accused game, Laser Battle, is a physical board game for playing a chess-like strategy game. Players take turns moving or rotating mirrored playing pieces so as to direct a laser beam to strike the opposing player's non-mirrored Tower playing piece to win the game. According to the rules of Laser Battle, in "Classic Game Play," the Tower pieces are placed on the board at the beginning of the game at one of various standard positions. Although the Towers are physically capable of movement on the game board, the rules provide that they "should always remain in their original positions on the board." However, the standard starting configuration illustrated in the rules show that the Tower pieces can be placed at different locations on the board, and the rules state that during "Advanced Game Play," the Towers need not remain in their standard positions.

## II

The district court . . . granted Innovention's motion for summary judgment of nonobviousness. The court first found that the Laser Chess references were non-analogous art because they described electronic, rather than real-world, laser games. The district court then held that, because MGA had provided no evidence to support a finding as to the level of ordinary skill in the art, MGA's obviousness argument could be pursued only on the basis of what would have been obvious to a layperson. The court then decided that because MGA had not provided any evidence that a layperson would have known of the Laser Chess articles or would have had any reason to modify the teachings of the Laser Chess references, MGA had failed to state a prima facie case of obviousness.

Finally, the court found that Innovention had demonstrated several secondary considerations of nonobviousness. These included (1) commercial success based on the sale of 140,000 games by Innovention, a small company with minimal marketing capabilities, and evidence that fans had started clubs and tournaments around the world; (2) long-felt need based on the game's sudden success and media praise; and (3) industry

praise based on, inter alia, the game's nomination for Outstanding Technology of the Year by the International Academy of Science and its being one of five finalists for the Toy Industry Association's 2007 Game of the Year award. In light of its summary judgment rulings, the district court granted Innovention's motion for a permanent injunction . . . .

MGA appealed. We have jurisdiction pursuant to 28 U.S.C. § 1295(a)(1).

### *Discussion*

This court reviews a district court's decision on summary judgment de novo, reapplying the same standard applied by the district court. Summary judgment is appropriate "if the movant shows that there is no genuine dispute as to any material fact and the movant is entitled to judgment as a matter of law." Fed. R. Civ. P. 56(a).

. . . .

## II

Under the Patent Act, "a patent may not be obtained if the differences between the subject matter sought to be patented and the prior art are such that the subject matter as a whole would have been obvious at the time the invention was made to a person having ordinary skill in the art to which said subject matter pertains." 35 U.S.C. § 103(a). Although the ultimate determination of obviousness under § 103 is a question of law, it is based on several underlying factual findings, including (1) the scope and content of the prior art; (2) the level of ordinary skill in the pertinent art; (3) the differences between the claimed invention and the prior art; and (4) evidence of secondary factors, such as commercial success, long-felt need, and the failure of others. *Graham v. John Deere Co.* A patent is presumed valid, 35 U.S.C. § 282, and this presumption can be overcome only by clear and convincing evidence to the contrary.

MGA argues that, rather than being nonobvious, the asserted claims would have been obvious based on the combination of the Laser Chess references, which teach the claimed game in electronic form, and the Swift patent, which teaches a physical laser-based game. According to MGA, the district court erred both (1) in concluding that because the '242 patent relates to a physical game, the Laser Chess articles were non-analogous art; and (2) in assuming that a person of skill in the art was a layperson rather than, as put forth by Innovention, a mechanical engineer with knowledge of optics. Finally, MGA argues, Innovention's unsupported and conclusory assertions of secondary considerations fail to overcome MGA's prima facie case of obviousness.

Innovention responds that the Laser Chess references in combination with the Swift patent fail to teach or suggest every limitation of the asserted claims, and thus MGA has failed to state a prima facie case of obviousness. Specifically, Innovention argues that Swift, as MGA admits, fails to disclose movable key pieces and that the Laser Chess

## NONOBVIOUSNESS

references fail to disclose any physical, non-virtual game components. Accordingly, Innovention argues that the Laser Chess references are non-analogous art because they are neither within the inventors' field of endeavor, i.e., a non-virtual, three-dimensional, laser board game, nor reasonably pertinent to it. Innovention also argues that because MGA offered no evidence as to the level of skill in the art, the skill level defaults to that of a layperson, and that its evidence of secondary considerations provides further evidence that the claimed invention would not have been obvious.

We conclude that the district court clearly erred in several of the factual findings underlying its obviousness analysis. The district court erred in finding that the Laser Chess references fail to qualify as analogous art. The court also erred in concluding that the level of skill in the art is that of a layperson. We address each in turn.

### A

A reference qualifies as prior art for a determination under § 103 when it is analogous to the claimed invention. *In re Clay*, 966 F.2d 656, 658 (Fed. Cir. 1992). "Two separate tests define the scope of analogous art: (1) whether the art is from the same field of endeavor, regardless of the problem addressed, and (2) if the reference is not within the field of the inventor's endeavor, whether the reference still is reasonably pertinent to the particular problem with which the inventor is involved." *In re Bigio*, 381 F.3d 1320, 1325 (Fed. Cir. 2004). "A reference is reasonably pertinent if it is one which, because of the matter with which it deals, logically would have commended itself to an inventor's attention in considering his problem." *Clay*, 966 F.2d at 659. "If a reference disclosure has the same purpose as the claimed invention, the reference relates to the same problem, and that fact supports use of that reference in an obviousness rejection." *Id.* Whether a prior art reference is "analogous" is a question of fact. *Id.* at 658.

Innovention argues that the Laser Chess articles are non-analogous art because the '242 patent's inventors were concerned with making a non-virtual, three-dimensional, laser-based board game, a project that involves mechanical engineering and optics, not computer programming. The district court appears to have agreed, finding that the Laser Chess references were non-analogous art since each discloses "an electronic version of the '242 patent." The court, however, failed to consider whether a reference disclosing an electronic, laser-based strategy game, even if not in the same field of endeavor, would nonetheless have been reasonably pertinent to the problem facing an inventor of a new, physical, laser-based strategy game. In this case, the district court clearly erred in not finding the Laser Chess references to be analogous art based on this test as a matter of law.

The '242 patent and the Laser Chess references are directed to the same purpose: detailing the specific game elements comprising a chess-like, laser-based strategy game.

Specifically, the '242 patent describes (1) the game's components, including the game board, and various types of playing pieces; (2) the game's specific rules, including how the pieces may move on the game board during a player's turn; and (3) the game's ultimate objective, namely, illuminating an opponent's key playing piece with a laser beam. The specification even distinguishes prior art patents based on these game elements, stating that U.S. Patent 3,516,671 lacks "the unique elements and rules of the ['242 patent's] invention," and U.S. Patent 6,702,286 contemplates a game in which the objective is not to "illuminate playing pieces," but rather "to maneuver one's pieces to flank (or surround) those of the opposing player."

The Laser Chess references likewise describe specific playing pieces, rules, and objectives to create a chess-like, laser-based strategy game. Both Laser Chess and Advanced Laser Chess disclose, for example, (1) various game pieces, each with unique capabilities; (2) rules for each player's turn; and (3) an ultimate objective of eliminating an opponent's king piece.

Accordingly, the '242 patent and the Laser Chess references relate to the same goal: designing a winnable yet entertaining strategy game. The '242 patent's specification confirms that game design was one objective facing its inventors. In particular, the specification states that "strategy games may differ in a variety of ways," such as in board layout, the number and types of playing pieces, and the manner in which each piece moves on the game board, and that "each of these variations affects the strategy of the play and the degree of skill required to play the game." The specification thus admonishes that if the game elements "are overly simplistic, the game is too easy, will usually end in a draw or a predictable manner, and quickly become uninteresting for the average player." Conversely, according to the specification, if the game elements "are overly complicated, the game takes too long to learn and is frustrating and uninteresting for the average player."

The specific combination of game elements disclosed and claimed in the '242 patent thus deals with the problem of game design, and game elements from any strategy game, regardless how implemented, "logically would have commended itself to an inventor's attention in considering this problem." *Clay*, 966 F.2d at 659. Basic game elements remain the same regardless of the medium in which they are implemented: whether molded in plastic by a mechanical engineer or coded in software by a computer scientist. And, as MGA's evidence shows, inventors of numerous prior art patents contemplated the implementation of their strategy games in both physical and electronic formats. For example, the Swift patent states that "although the preferred embodiment is played by two players, obvious modifications of the game allow for a single player playing against a computer." Thus, because no reasonable jury could find that the Laser Chess references

## NONOBVIOUSNESS

do not qualify as analogous prior art, and the district court erred in not so concluding as a matter of law.

Because of its error, the district court failed to properly consider the scope and content of the relevant prior art as well as the differences between that art and the claimed invention, including whether one of ordinary skill in the art would have been motivated to combine the teachings of the Laser Chess references with the Swift patent in light of the standard articulated in *KSR International Co. v. Teleflex, Inc.* We therefore remand these factual determinations to the district court to consider in the first instance. Furthermore, should the district court conclude that MGA has made out a prima facie case of obviousness based on the Laser Chess articles and the Swift patent, the court must then determine whether Innovention's secondary considerations overcome MGA's prima facie case.

### B

A determination of obviousness requires a factual finding of the level of ordinary skill in the art. Yet, a district court's failure to make a correct finding on the level of skill constitutes reversible error only where it affects the ultimate conclusion under § 103. For example, no reversal is necessary where a district court makes a determination that an invention would have been obvious to one having the lowest level of skill, i.e., a layperson, because what is obvious to a layperson is necessarily obvious to one with a higher level of skill in the field of the invention. Conversely, no reversal is necessary where a district court makes a determination of nonobviousness based on a finding of the highest possible level of skill in the relevant art, as fewer inventions are obvious to a person with a lower level of skill than to one with a higher level of skill. A less sophisticated level of skill generally favors a determination of nonobviousness, and thus the patentee, while a higher level of skill favors the reverse.

In this case, the district court found that MGA had failed to provide any evidence of the level of skill in the art, and thus concluded that MGA's obviousness argument could be pursued only on the basis of what is obvious to a layperson. In so concluding, the district court erred. While MGA is permitted to argue that any level of skill, and thus the skill of a layperson, would suffice to support a holding of obviousness, the factual record in this case does not support such a finding. Here, Innovention conceded to the district court that the level of ordinary skill in the art was greater than that of a layperson. Specifically, Innovention asserted that the development of a three-dimensional game would not, in fact, be easy for the average layperson, as it took Innovention's game creators, a Ph.D. in mechanical engineering and two mechanical engineering students, a year and a half to develop and finalize Innovention's game and that Innovention's patent reveals that the claimed invention requires an understanding of geometrical optics. The district court appeared to agree, stating that "it seems some knowledge of mechanical

engineering or optics is required.” The district court thus clearly erred in basing its obviousness analysis on what would have been obvious to a layperson notwithstanding evidence in the record and its apparent factual finding that one of ordinary skill in the art would possess a higher level of skill in the art.

Because the district court found nonobviousness based on an inappropriately low level of skill in the art, the error was not harmless. Accordingly, on remand, the district court must make a finding on the level of skill in the art and base its obviousness analysis on that level of skill.

### *Conclusion*

For the foregoing reasons, we affirm the district court's grant of summary judgment of literal infringement, and we vacate and remand the district court's grant of summary judgment of nonobviousness.

### Context & Application

1. What are the two tests for analogous art? What do the cases we've read tell us about what it means for an invention to be in the same “field of endeavor” as something else? What do they tell us about whether a reference would be “reasonably pertinent”?

2. Why do you think courts have limited the scope of prior art that can be used in analyzing validity under § 103? In other words, why not use the full scope of things that count as prior art under § 102 when analyzing validity under § 103?

3. What does the Federal Circuit say was wrong with the District Court's analysis in *Innovention Toys*? Who got it right—are these the kinds of references you think should be considered analogous art?

4. Would you consider a toothbrush to be analogous art for a hairbrush? In *In re Bigio*, the Board of Patent Appeals and Interferences ruled that a reference directed to a toothbrush was from the same field of invention as a claimed design for a hair brush because both were “hand-held brushes having a handle segment and a bristle substrate segment.” See 381 F.3d 1320, 1325 (Fed. Cir. 2004). The Federal Circuit affirmed:

Bigio argues that the “field of endeavor” test for analogous art is unworkable because the lack of clear guidelines leaves the application of this test to an examiner's subjective judgment. To the contrary, the field of endeavor test is neither wholly subjective nor unworkable. This test for analogous art requires the PTO to determine the appropriate field of endeavor by reference to explanations of the invention's subject matter in the patent application, including the embodiments, function, and structure of the claimed invention.

...

[T]he Board determined that the [toothbrush] reference fell within the scope of arts analogous to the claimed invention. Because substantial evidence supports the Board's factual findings regarding the function and structure of the toothbrush art, this court affirms those findings.

*Id.* at 1325–26. Judge Newman dissented:

The toothbrush art is not analogous to the hair brush art. Bigio's patent application is directed to a hair brush, and his claims are limited to a hair brush. A brush for hair has no more relation to a brush for teeth than does hair resemble teeth.

The mode and mechanics of brushing teeth cannot reasonably be viewed as analogous to the mode and mechanics of brushing hair. To state the obvious: teeth require a brush that penetrates around the edges of relatively large and hard substrates, a brush that administers a soapy abrasive, a brush that works in the up-and-down and circular motion needed to scrub teeth; a brush for hair must serve entirely different shapes and textures and purposes. Neither the PTO nor my colleagues on this panel points to any ground on which a person seeking to design an improved hairbrush would deem the toothbrush art to be a source of usable technology, and thus "analogous," whereby that source is relevant to a determination of obviousness.

*Id.* at 1327 (Newman, J., dissenting). Which side—the majority or dissent—do you find more convincing? Also note that the case cited by Judge Newman talks about whether the use of a certain field or technology "would be suggested or motivated or taught, by sources in the prior art." How, if at all, might the Supreme Court's decision in *KSR* affect the strength of that precedent?

3. What is the relationship between § 112 and § 103? According to the Federal Circuit:

To render a claim obvious, the prior art, taken as a whole, must enable a skilled artisan to make and use the claimed invention. In general, a prior art reference asserted under § 103 does not necessarily have to enable its own disclosure, i.e., be "self-enabling," to be relevant to the obviousness inquiry. . . .

But even though a non-enabling reference can play a role in an obviousness analysis, the evidence of record must still establish that a skilled artisan could have made the claimed invention. . . .

In the absence of . . . other supporting evidence to enable a skilled artisan to make the claimed invention, a standalone § 103 reference must enable the portions of its disclosure being relied upon. In this context the reference must necessarily enable

the relied-upon portion of its own disclosure—the same standard applied to anticipatory references.

*Raytheon Techs. Corp. v. Gen. Elec. Co.*, 993 F.3d 1374, 1380–81 (Fed. Cir. 2021). What do the cases we’ve read so far suggest about what kinds of “other supporting evidence” could (or should) be used in this context?

4. What role does the level of skill in the art play in a § 103 analysis? The Federal Circuit has said:

[T]he level of skill in the art is a prism or lens through which a judge, jury, or the Board views the prior art and the claimed invention. This reference point prevents these factfinders from using their own insight or, worse yet, hindsight, to gauge obviousness. Skill in the art does not act as a bridge over gaps in substantive presentation of an obviousness case, but instead supplies an important guarantee of objectivity in the process.

*Okajima v. Bourdeau*, 261 F.3d 1350, 1354–55 (Fed. Cir. 2001).

5. What happens if a court (or the PTAB) does not make a specific finding as to the level of skill in the art? The Federal Circuit has repeatedly held that is not always a fatal error:

Genzyme’s third argument is that the Board erred by not making an explicit finding as to the level of skill of a person of ordinary skill as part of its obviousness analysis. This court has explained that the failure to make explicit findings regarding the level of skill in the art does not constitute reversible error when “the prior art itself reflects an appropriate level and a need for testimony is not shown.”

Here the Board’s failure to make an explicit finding as to the level of skill is not reversible error because both parties proposed nearly identical language to describe a person of ordinary skill. Both proposed that such a person is a medical doctor or a Ph.D. in a biology-related field, has experience in lysosomal diseases, and has experience developing drugs and treatments for patients. Genzyme has not shown that there are any meaningful differences between its proposed definition of a person of ordinary skill and Biomarin’s, or that the outcome of this case would have been different based on which definition the Board used. The Board’s failure to make a specific finding as to the level of skill is therefore not reversible error.

*Genzyme Therapeutic Prod. Ltd. P’ship v. Biomarin Pharm. Inc.*, 825 F.3d 1360, 1371–72 (Fed. Cir. 2016). And if the parties don’t raise the issue, the court is not necessarily required to raise it *sua sponte*:



## NONOBVIOUSNESS

Failure to address the level of skill in the art is not error when the parties do not put such a determination at issue and when the level of an artisan's skill is evident from the prior art and patent. While it is preferable that the fact finder specify the level of skill it has found to apply to the invention at issue, "the absence of specific findings on the level of skill in the art does not give rise to reversible error where the prior art itself reflects an appropriate level and a need for testimony is not shown."

*Rudolph Techs., Inc. v. Camtek, Ltd.*, 666 F. App'x 925, 931 (Fed. Cir. 2016).

6. What happens when people research in teams? Pre-AIA § 103(c) created a "safe harbor" of sorts for certain researchers. As Margo Bagley has explained:

Prior to [2004], the joint collaboration of coworkers for the same employer could not be used as prior art for obviousness against later work, but that protection did not extend to the collaborations of coworkers from different organizations, such as those in university-industry joint research agreements. The CREATE Act eliminated the "same/different" organization distinction by disqualifying from the state of the art for determining obviousness information that is the work of researchers from different research organizations if there had been a pre-existing agreement for research collaboration.

*Academic Discourse and Proprietary Rights: Putting Patents in Their Proper Place*, 47 B.C. L. REV. 217, 237 (2006).

In enacting the CREATES Act, Congress rejected "the Court of Appeals for the Federal Circuit's 1995 *OddzOn v. Just Toys* decision." *Id.* at 236. In *OddzOn*, the Federal Circuit held that, under the pre-2004 version of § 103(c), "subject matter derived from another not only is itself unpatentable to the party who derived it under § 102(f), but, when combined with other prior art, may make a resulting obvious invention unpatentable to that party under a combination of §§ 102(f) and 103." *OddzOn Prod., Inc. v. Just Toys, Inc.*, 122 F.3d 1396, 1403–04 (Fed. Cir. 1997). Can you see why this was a problem for some joint researchers?

Following the 2004 enactment of the CREATES Act, § 103(c) read as follows:

- (1) Subject matter developed by another person, which qualifies as prior art only under one or more of subsections (e), (f), and (g) of section 102 of this title, shall not preclude patentability under this section where the subject matter and the claimed invention were, at the time the claimed invention was made, owned by the same person or subject to an obligation of assignment to the same person.
- (2) For purposes of this subsection, subject matter developed by another person and a claimed invention shall be deemed to have been owned by the same person or subject to an obligation of assignment to the same person if--

## CHAPTER 7

(A) the claimed invention was made by or on behalf of parties to a joint research agreement that was in effect on or before the date the claimed invention was made;

(B) the claimed invention was made as a result of activities undertaken within the scope of the joint research agreement; and

(C) the application for patent for the claimed invention discloses or is amended to disclose the names of the parties to the joint research agreement.

(3) For purposes of paragraph (2), the term “joint research agreement” means a written contract, grant, or cooperative agreement entered into by two or more persons or entities for the performance of experimental, developmental, or research work in the field of the claimed invention.

When Congress passed the AIA, however, it eliminated § 103(c). Can you see why? (Hint: Review how the AIA defines what counts as prior art under § 102 (b)(2)(C) and § 102(c).)

## 8. CLAIM CONSTRUCTION

The patent statute provides that each patent “specification shall conclude with one or more claims particularly pointing out and distinctly claiming the subject matter which the inventor or a joint inventor regards as the invention.” 35 U.S.C. § 112(b). Claims perform a vital role in the modern patent system: for utility patents, they define the boundaries of the patentee’s legal rights. As a result, claims form the foundation for analyses of validity and infringement. Because of their importance, patent applicants, patentees, and accused infringers frequently engage in disputes about their meaning. The process by which these disputes are resolved is referred to as claim construction. That is the focus of this chapter.

The problems of claim construction are similar to those that arise in other areas, like the interpretation of statutes and contracts. Claim construction does, however, present some unique twists on these familiar problems. Some of this is due to the technical nature of the underlying inventions, which is unfamiliar to many of the potential decision-makers. Some of it is due to the novelty of the underlying inventions, which makes it more likely that the words used in the patent will lack settled definitions. And some of it is due to the back-and-forth between the inventor and the patent examiner that produces claim language. As you read the material in this chapter, consider whether the problems that arise fit within familiar patterns from other areas of the law—and are accordingly amenable to familiar solutions—or instead appear distinct from other areas, justifying special treatment.

### A. Interpreting Claims

#### 1. The *Phillips* Framework

In *Phillips v. AWH Corp.*, the Federal Circuit established the framework that governs claim construction disputes today. See 415 F.3d 1303 (Fed. Circ. 2005) (*en banc*). The focus of the case is on the weight that courts should place on the various sources used to resolve claim construction questions. In particular, *Phillips* addressed some tension in prior Federal Circuit cases regarding the role of the patent document itself as compared to other sources like dictionaries. As you read the case, consider how you might apply its framework to resolve debates about the meaning of patent language claiming inventions in fields of technology with which you are not familiar.

CHAPTER 8

*Phillips v. AWH Corp.*  
415 F.3d 1303 (Fed. Cir. 2005) (*en banc*)

BRYSON, Circuit Judge.

Edward H. Phillips invented modular, steel-shell panels that can be welded together to form vandalism-resistant walls. The panels are especially useful in building prisons because they are load-bearing and impact-resistant, while also insulating against fire and noise. Mr. Phillips obtained a patent on the invention, U.S. Patent No. 4,677,798, and he subsequently entered into an arrangement with AWH Corporation, Hopeman Brothers, Inc., and Lofton Corporation (collectively “AWH”) to market and sell the panels. That arrangement ended in 1990. In 1991, however, Mr. Phillips received a sales brochure from AWH that suggested to him that AWH was continuing to use his . . . patented technology without his consent. . . .

In February 1997, Mr. Phillips brought suit in the United States District Court for the District of Colorado charging AWH with . . . infringement of claims 1, 21, 22, 24, 25, and 26 of the ’798 patent. . . .

. . .

This court agreed to rehear the appeal *en banc* and vacated the judgment of the panel. We . . . reverse the portion of the court’s judgment addressed to the issue of infringement.

I

Claim 1 of the ’798 patent is representative of the asserted claims with respect to the use of the term “baffles.” It recites:

Building modules adapted to fit together for construction of fire, sound and impact resistant security barriers and rooms for use in securing records and persons, comprising in combination, an outer shell . . . , sealant means . . . and further means disposed inside the shell for increasing its load bearing capacity comprising internal steel baffles extending inwardly from the steel shell walls.

. . . [W]e must determine the correct construction of the structural term “baffles,” as used in the ’798 patent.

II

The first paragraph of section 112 of the Patent Act, 35 U.S.C. § 112, states that the specification

shall contain a written description of the invention, and of the manner and process of making and using it, in such full, clear, concise, and exact terms as to enable any person skilled in the art to which it pertains . . . to make and use the same . . . .

## CLAIM CONSTRUCTION

The second paragraph of section 112 provides that the specification

shall conclude with one or more claims particularly pointing out and distinctly claiming the subject matter which the applicant regards as his invention.

Those two paragraphs of section 112 frame the issue of claim interpretation for us. The second paragraph requires us to look to the language of the claims to determine what “the applicant regards as his invention.” On the other hand, the first paragraph requires that the specification describe the invention set forth in the claims. The principal question that this case presents to us is the extent to which we should resort to and rely on a patent’s specification in seeking to ascertain the proper scope of its claims.

This is hardly a new question. The role of the specification in claim construction has been an issue in patent law decisions in this country for nearly two centuries. . . .

### A

It is a “bedrock principle” of patent law that “the claims of a patent define the invention to which the patentee is entitled the right to exclude.” That principle has been recognized since at least 1836, when Congress first required that the specification include a portion in which the inventor “shall particularly specify and point out the part, improvement, or combination, which he claims as his own invention or discovery.” Act of July 4, 1836, ch. 357, § 6, 5 Stat. 117, 119. In the following years, the Supreme Court made clear that the claims are “of primary importance, in the effort to ascertain precisely what it is that is patented.” *Merrill v. Yeomans*, 94 U.S. 568, 570 (1876). Because the patentee is required to “define precisely what his invention is,” the Court explained, it is “unjust to the public, as well as an evasion of the law, to construe it in a manner different from the plain import of its terms.”

We have frequently stated that the words of a claim “are generally given their ordinary and customary meaning,” [which] is the meaning that the term would have to a person of ordinary skill in the art in question at the time of the invention, i.e., as of the effective filing date of the patent application.

The inquiry into how a person of ordinary skill in the art understands a claim term provides an objective baseline from which to begin claim interpretation. That starting point is based on the well-settled understanding that inventors are typically persons skilled in the field of the invention and that patents are addressed to and intended to be read by others of skill in the pertinent art.

Importantly, the person of ordinary skill in the art is deemed to read the claim term not only in the context of the particular claim in which the disputed term appears, but in the context of the entire patent, including the specification. This court explained . . . :

It is the person of ordinary skill in the field of the invention through whose eyes the claims are construed. Such person is deemed to read the words used in the patent documents with an understanding of their meaning in the field, and to have knowledge of any special meaning and usage in the field. The inventor's words that are used to describe the invention—the inventor's lexicography—must be understood and interpreted by the court as they would be understood and interpreted by a person in that field of technology. Thus the court starts the decisionmaking process by reviewing the same resources as would that person, *viz.*, the patent specification and the prosecution history.

## B

In some cases, the ordinary meaning of claim language as understood by a person of skill in the art may be readily apparent even to lay judges, and claim construction in such cases involves little more than the application of the widely accepted meaning of commonly understood words. In such circumstances, general purpose dictionaries may be helpful. In many cases that give rise to litigation, however, determining the ordinary and customary meaning of the claim requires examination of terms that have a particular meaning in a field of art. Because the meaning of a claim term as understood by persons of skill in the art is often not immediately apparent, and because patentees frequently use terms idiosyncratically, the court looks to “those sources available to the public that show what a person of skill in the art would have understood disputed claim language to mean.” Those sources include “the words of the claims themselves, the remainder of the specification, the prosecution history, and extrinsic evidence concerning relevant scientific principles, the meaning of technical terms, and the state of the art.”

## 1

[T]he claims themselves provide substantial guidance as to the meaning of particular claim terms.

To begin with, the context in which a term is used in the asserted claim can be highly instructive. To take a simple example, the claim in this case refers to “steel baffles,” which strongly implies that the term “baffles” does not inherently mean objects made of steel. . . .

Other claims of the patent in question, both asserted and unasserted, can also be valuable sources of enlightenment as to the meaning of a claim term. Because claim terms are normally used consistently throughout the patent, the usage of a term in one claim can often illuminate the meaning of the same term in other claims. Differences among claims can also be a useful guide in understanding the meaning of particular claim terms. For example, the presence of a dependent claim that adds a particular limitation gives rise to a presumption that the limitation in question is not present in the independent claim.

## CLAIM CONSTRUCTION

2

The claims, of course, do not stand alone. Rather, they are part of “a fully integrated written instrument,” consisting principally of a specification that concludes with the claims. For that reason, claims “must be read in view of the specification, of which they are a part.” [T]he specification “is always highly relevant to the claim construction analysis. Usually, it is dispositive; it is the single best guide to the meaning of a disputed term.”

...

The importance of the specification in claim construction derives from its statutory role. The close kinship between the written description and the claims is enforced by the statutory requirement that the specification describe the claimed invention in “full, clear, concise, and exact terms.” 35 U.S.C. § 112, ¶ 1. In light of the statutory directive that the inventor provide a “full” and “exact” description of the claimed invention, the specification necessarily informs the proper construction of the claims. In *Renishaw*, this court summarized that point succinctly:

Ultimately, the interpretation to be given a term can only be determined and confirmed with a full understanding of what the inventors actually invented and intended to envelop with the claim. The construction that stays true to the claim language and most naturally aligns with the patent’s description of the invention will be, in the end, the correct construction.

158 F.3d at 1250.

Consistent with that general principle, our cases recognize that the specification may reveal a special definition given to a claim term by the patentee that differs from the meaning it would otherwise possess. In such cases, the inventor’s lexicography governs. In other cases, the specification may reveal an intentional disclaimer, or disavowal, of claim scope by the inventor. In that instance as well, the inventor has dictated the correct claim scope, and the inventor’s intention, as expressed in the specification, is regarded as dispositive.

The pertinence of the specification to claim construction is reinforced by the manner in which a patent is issued. The Patent and Trademark Office determines the scope of claims in patent applications not solely on the basis of the claim language, but upon giving claims their broadest reasonable construction “in light of the specification as it would be interpreted by one of ordinary skill in the art.” Indeed, the rules of the PTO require that application claims must “conform to the invention as set forth in the remainder of the specification and the terms and phrases used in the claims must find clear support or

antecedent basis in the description so that the meaning of the terms in the claims may be ascertainable by reference to the description.” 37 C.F.R. § 1.75(d)(1). . . .

## 3

In addition to consulting the specification, we have held that a court “should also consider the patent’s prosecution history, if it is in evidence.” The prosecution history, which we have designated as part of the “intrinsic evidence,” consists of the complete record of the proceedings before the PTO and includes the prior art cited during the examination of the patent. Like the specification, the prosecution history provides evidence of how the PTO and the inventor understood the patent. Furthermore, like the specification, the prosecution history was created by the patentee in attempting to explain and obtain the patent. Yet because the prosecution history represents an ongoing negotiation between the PTO and the applicant, rather than the final product of that negotiation, it often lacks the clarity of the specification and thus is less useful for claim construction purposes. Nonetheless, the prosecution history can often inform the meaning of the claim language by demonstrating how the inventor understood the invention and whether the inventor limited the invention in the course of prosecution, making the claim scope narrower than it would otherwise be.

## C

Although we have emphasized the importance of intrinsic evidence in claim construction, we have also authorized district courts to rely on extrinsic evidence, which “consists of all evidence external to the patent and prosecution history, including expert and inventor testimony, dictionaries, and learned treatises.” However, while extrinsic evidence “can shed useful light on the relevant art,” we have explained that it is “less significant than the intrinsic record in determining the legally operative meaning of claim language.”

Within the class of extrinsic evidence, the court has observed that dictionaries and treatises can be useful in claim construction. We have especially noted the help that technical dictionaries may provide to a court “to better understand the underlying technology” and the way in which one of skill in the art might use the claim terms. Because dictionaries, and especially technical dictionaries, endeavor to collect the accepted meanings of terms used in various fields of science and technology, those resources have been properly recognized as among the many tools that can assist the court in determining the meaning of particular terminology to those of skill in the art of the invention. Such evidence, we have held, may be considered if the court deems it helpful in determining “the true meaning of language used in the patent claims.”

We have also held that extrinsic evidence in the form of expert testimony can be useful to a court for a variety of purposes, such as to provide background on the technology at



## CLAIM CONSTRUCTION

issue, to explain how an invention works, to ensure that the court's understanding of the technical aspects of the patent is consistent with that of a person of skill in the art, or to establish that a particular term in the patent or the prior art has a particular meaning in the pertinent field. However, conclusory, unsupported assertions by experts as to the definition of a claim term are not useful to a court. Similarly, a court should discount any expert testimony "that is clearly at odds with the claim construction mandated by the claims themselves, the written description, and the prosecution history, in other words, with the written record of the patent."

We have viewed extrinsic evidence in general as less reliable than the patent and its prosecution history in determining how to read claim terms, for several reasons. First, extrinsic evidence by definition is not part of the patent and does not have the specification's virtue of being created at the time of patent prosecution for the purpose of explaining the patent's scope and meaning. Second, while claims are construed as they would be understood by a hypothetical person of skill in the art, extrinsic publications may not be written by or for skilled artisans and therefore may not reflect the understanding of a skilled artisan in the field of the patent. Third, extrinsic evidence consisting of expert reports and testimony is generated at the time of and for the purpose of litigation and thus can suffer from bias that is not present in intrinsic evidence. The effect of that bias can be exacerbated if the expert is not one of skill in the relevant art or if the expert's opinion is offered in a form that is not subject to cross-examination. Fourth, there is a virtually unbounded universe of potential extrinsic evidence of some marginal relevance that could be brought to bear on any claim construction question. In the course of litigation, each party will naturally choose the pieces of extrinsic evidence most favorable to its cause, leaving the court with the considerable task of filtering the useful extrinsic evidence from the fluff. Finally, undue reliance on extrinsic evidence poses the risk that it will be used to change the meaning of claims in derogation of the "indisputable public records consisting of the claims, the specification and the prosecution history," thereby undermining the public notice function of patents.

In sum, extrinsic evidence may be useful to the court, but it is unlikely to result in a reliable interpretation of patent claim scope unless considered in the context of the intrinsic evidence. Nonetheless, because extrinsic evidence can help educate the court regarding the field of the invention and can help the court determine what a person of ordinary skill in the art would understand claim terms to mean, it is permissible for the district court in its sound discretion to admit and use such evidence. In exercising that discretion, and in weighing all the evidence bearing on claim construction, the court should keep in mind the flaws inherent in each type of evidence and assess that evidence accordingly.

## CHAPTER 8

### IV

#### A

The critical language of claim 1 of the '798 patent—"further means disposed inside the shell for increasing its load bearing capacity comprising internal steel baffles extending inwardly from the steel shell walls"—imposes three clear requirements with respect to the baffles. First, the baffles must be made of steel. Second, they must be part of the load-bearing means for the wall section. Third, they must be pointed inward from the walls. Both parties, stipulating to a dictionary definition, also conceded that the term "baffles" refers to objects that check, impede, or obstruct the flow of something. The intrinsic evidence confirms that a person of skill in the art would understand that the term "baffles," as used in the '798 patent, would have that generic meaning.

The other claims of the '798 patent specify particular functions to be served by the baffles. For example, dependent claim 2 states that the baffles may be "oriented with the panel sections disposed at angles for deflecting projectiles such as bullets able to penetrate the steel plates." The inclusion of such a specific limitation on the term "baffles" in claim 2 makes it likely that the patentee did not contemplate that the term "baffles" already contained that limitation. Independent claim 17 . . . states that baffles are placed "projecting inwardly from the outer shell at angles tending to deflect projectiles that penetrate the outer shell." That limitation would be unnecessary if persons of skill in the art understood that the baffles inherently served such a function. Dependent claim 6 . . . stat[es] that "the internal baffles of both outer panel sections overlap and interlock at angles providing deflector panels extending from one end of the module to the other." If the baffles recited in claim 1 were inherently placed at specific angles, or interlocked to form an intermediate barrier, claim 6 would be redundant.

The specification further supports the conclusion that persons of ordinary skill in the art would understand the baffles recited in the '798 patent to be load-bearing objects that serve to check, impede, or obstruct flow. At several points, the specification discusses positioning the baffles so as to deflect projectiles. The patent states that one advantage of the invention over the prior art is that "[t]here have not been effective ways of dealing with these powerful impact weapons with inexpensive housing." While that statement makes clear the invention envisions baffles that serve that function, it does not imply that in order to qualify as baffles within the meaning of the claims, the internal support structures must serve the projectile-deflecting function in all the embodiments of all the claims. The specification must teach and enable all the claims, and the section of the written description discussing the use of baffles to deflect projectiles serves that purpose for claims 2, 6, 17, and 23, which specifically claim baffles that deflect projectiles.

CLAIM CONSTRUCTION

The specification discusses several other purposes served by the baffles. For example, the baffles are described as providing structural support. . . . The baffle 16 is described as a "strengthening triangular baffle." . . . Figures 4 and 6 do not show the baffles as part of an "intermediate interlocking, but not solid, internal barrier." In those figures, the baffle 16 simply provides structural support . . . :

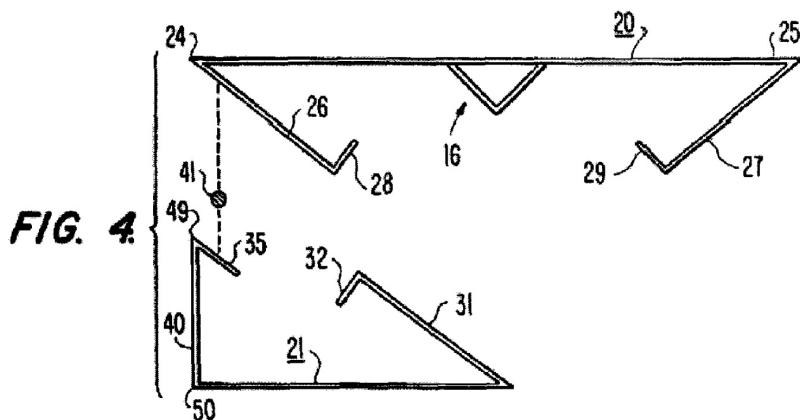
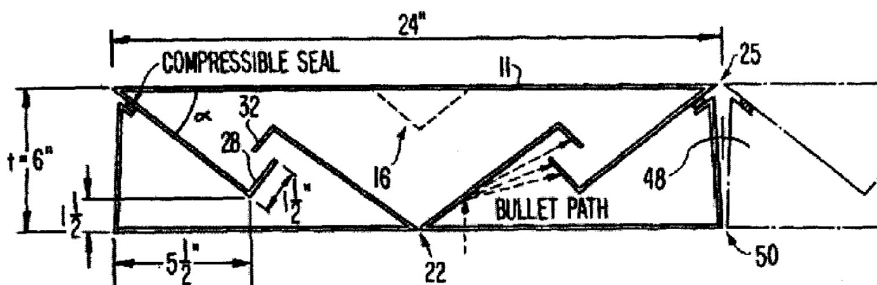
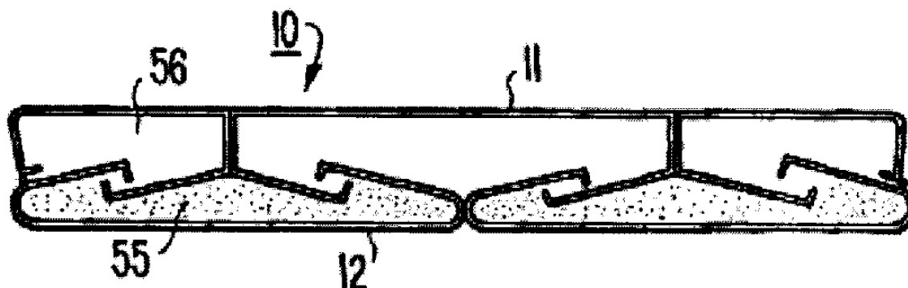

FIG. 6.



Other uses for the baffles are listed in the specification as well. In Figure 7, the overlapping flanges "provide for overlapping and interlocking the baffles to produce substantially an intermediate barrier wall between the opposite wall faces":



Those baffles thus create small compartments that can be filled with either sound and thermal insulation or rock and gravel to stop projectiles. By separating the interwall area into compartments, the user of the modules can choose different types of material for each compartment, so that the module can be “easily custom tailored for the specific needs of each installation.” When material is placed into the wall during installation, the baffles obstruct the flow of material from one compartment to another so that this “custom tailoring” is possible.

. . . We have held that “the fact that a patent asserts that an invention achieves several objectives does not require that each of the claims be construed as limited to structures that are capable of achieving all of the objectives.” Although deflecting projectiles is one of the advantages of the baffles of the ’798 patent, the patent does not require that the inward extending structures always be capable of performing that function. Accordingly, we conclude that a person of skill in the art would not interpret the disclosure and claims of the ’798 patent to mean that a structure extending inward from one of the wall faces is a “baffle” if it is at an acute or obtuse angle, but is not a “baffle” if it is disposed at a right angle.

## B

Invoking the principle that “claims should be so construed, if possible, as to sustain their validity,” AWH argues that the term “baffles” should be given a restrictive meaning . . . .

While we have acknowledged the maxim that claims should be construed to preserve their validity, we have not applied that principle broadly, and we have certainly not endorsed a regime in which validity analysis is a regular component of claim construction. Instead, we have limited the maxim to cases in which “the court concludes, after applying all the available tools of claim construction, that the claim is still ambiguous.” In such cases, we have looked to whether it is reasonable to infer that the PTO would not have issued an invalid patent, and that the ambiguity in the claim language should therefore be resolved in a manner that would preserve the patent’s validity.

. . .

In this case, . . . the claim term at issue is not ambiguous. Thus, it can be construed without the need to consider whether one possible construction would render the claim invalid while the other would not. The doctrine of construing claims to preserve their validity, a doctrine of limited utility in any event, therefore has no applicability here.

MAYER, Circuit Judge, with whom NEWMAN, Circuit Judge, joins, dissenting.

Now more than ever I am convinced of the futility, indeed the absurdity, of this court’s persistence in adhering to the falsehood that claim construction is a matter of law devoid

## CLAIM CONSTRUCTION

of any factual component. Because any attempt to fashion a coherent standard under this regime is pointless, as illustrated by our many failed attempts to do so, I dissent.

...

In the name of uniformity, *Cybor Corp. v. FAS Technologies, Inc.*, 138 F.3d 1448 (Fed. Cir. 1998) (*en banc*), held that claim construction does not involve subsidiary or underlying questions of fact and that we are, therefore, unbridled by either the expertise or efforts of the district court. What we have wrought, instead, is the substitution of a black box, as it so pejoratively has been said of the jury, with the black hole of this court. Out of this void we emit “legal” pronouncements by way of “interpretive necromancy”; these rulings resemble reality, if at all, only by chance. Regardless, and with a blind eye to the consequences, we continue to struggle under this irrational and reckless regime, trying every alternative—dictionaries first, dictionaries second, never dictionaries, etc., etc., etc.

...

While this court may persist in the delusion that claim construction is a purely legal determination, unaffected by underlying facts, it is plainly not the case. Claim construction is, or should be, made in context: a claim should be interpreted both from the perspective of one of ordinary skill in the art and in view of the state of the art at the time of invention. These questions, which are critical to the correct interpretation of a claim, are inherently factual. They are hotly contested by the parties, not by resort to case law as one would expect for legal issues, but based on testimony and documentary evidence. During so called *Markman* “hearings,” which are often longer than jury trials, parties battle over experts offering conflicting evidence regarding who qualifies as one of ordinary skill in the art; the meaning of patent terms to that person; the state of the art at the time of the invention; contradictory dictionary definitions and which would be consulted by the skilled artisan; the scope of specialized terms; the problem a patent was solving; what is related or pertinent art; whether a construction was disallowed during prosecution; how one of skill in the art would understand statements during prosecution; and on and on. In order to reconcile the parties’ inconsistent submissions and arrive at a sound interpretation, the district court is required to sift through and weigh volumes of evidence. While this court treats the district court as an intake clerk, whose only role is to collect, shuffle and collate evidence, the reality, as revealed by conventional practice, is far different.

...

Eloquent words can mask much mischief. The court’s opinion today is akin to rearranging the deck chairs on the Titanic—the orchestra is playing as if nothing is amiss, but the ship is still heading for Davey Jones’ locker.

## Context &amp; Application

1. The dissent mentions “*Markman* hearings.” This proceeding is named after the case that established that there is no Seventh Amendment right to a jury determination of claim interpretation. We’ll read more about *Markman* later in this chapter.

2. In the *Phillips* framework, claim terms must be given their “ordinary and customary meaning,” which “is the meaning that the term would have to a person of ordinary skill in the art in question at the time of the invention.” The Federal Circuit also established a hierarchy of sources for resolving disputes about claim language. Intrinsic evidence—that is, evidence from the patent document itself or the process by which it was obtained—takes precedence over extrinsic evidence like dictionaries and expert testimony. Suppose you had to determine the “ordinary and customary meaning” of a claim term “to a person of ordinary skill in the art” of the technology at issue in *Phillips* (i.e., modular wall design). How would you go about doing so? What sources would you use? What are the relative advantages and disadvantages of those sources? What if the technology at issue was in the field of software or cardiovascular stents or robotics? What do your answers suggest about the *Phillips* framework and the challenges of claim construction more generally?

3. *Phillips* says that the “starting point” for claim construction “is based on the well-settled understanding that inventors are typically persons skilled in the field of the invention and that patents are addressed to and intended to be read by others of skill in the pertinent art.” Who do you think actually reads patents? Who is the intended audience for a patent? Does your answer depend on which part of the patent we are focused on: the claims or the rest of the specification? For some theoretical perspectives, see Alan Devlin *The Misunderstood Function of Disclosure in Patent Law*, 23 HARV. J.L. & TECH. 401 (2010); Sean B. Seymore, *The Teaching Function of Patents*, 85 NOTRE DAME L. REV. 621 (2010); Jeanne C. Fromer, *Patent Disclosure*, 94 IOWA L. REV. 539 (2009). For empirical investigations of these questions, see Lisa Larrimore Ouellette, *Who Reads Patents?*, 35 NATURE BIOTECH. 421 (2017); Lisa Larrimore Ouellette, *Do Patents Disclose Useful Information?*, 25 HARVARD J.L. & TECH. 531 (2012).

4. The Federal Circuit has often warned against reading limitations from the specification into the claim. The idea is that, while the specification is designed to disclose technical information about how to make and use the invention, the claims must define the outer boundaries of the patentee’s rights. But the technical disclosure is not coextensive with the outer boundaries of the patentee’s rights; as *Phillips* explains, the technical disclosure might focus more narrowly on particular aspects of the invention. The patent system must therefore avoid using the technical disclosure in the specification to narrow the scope of the claims.

## CLAIM CONSTRUCTION

At the same time, the court tells us that the claims must be read in light of the specification. The idea here is that claim language is often somewhat bare-bones, but the specification provides much more detail on the invention. The specification might accordingly inform a reader as to how the words in the claims are being used. That is, because the claims themselves may well not provide sufficient context for discerning their meaning, the patent system should turn to the specification for that context, as would the skilled artisans who are the intended audience of the patent document.

The risk, according to *Phillips*, is that the context of the specification might appear to narrow the scope of the claim, even though the claim might permissibly reach embodiments of the invention that are not described in much detail in the specification (as an aside, why do you think that might happen?). Does *Phillips* provide adequate tools for mitigating this risk while still permitting adequate flexibility for judges and jurors to rely on the specification to learn about the invention and the way skilled artisans might understand the claims?

5. Lawyers and scholars have long debated the suitability of dictionaries for resolving disputes about the meanings of words in constitutions, statutes, contracts, and other legal texts. Many of the advantages and criticisms of dictionaries apply with equal force to claim construction. Should the patent system resolve some of these concerns by demanding that patent applicants specify, as part of their applications, which dictionary should be used to resolve ambiguities? Note also that some dictionaries are designed to be “descriptive” (i.e., to capture the meanings used by speakers of the language) or “prescriptive” (i.e., to include only meanings that are “correct,” at least in the view of the dictionary’s editors). Which dictionary design do you think would be a more appropriate source for claim construction?

6. *Phillips* endorses the canon that an inventor may act as her own lexicographer. Although lexicographers ordinarily explicitly articulate the definitions they are applying to words, this canon of claim construction is most often invoked to support an implicit definition drawn from the specification. How does this square with the warning about importing limitations from the specification into the claim?

7. Courts have developed a vast array of canons of claim constructions. Some of these are identified in *Phillips*. Like canons of statutory interpretation, it can seem that there is a canon to support any position one may wish to adopt in a particular case. Still, it’s worth paying some attention to them because courts frequently assert that they help guide their decisions. In addition to the “patentee as lexicographer” canon, another commonly invoked canon found in *Phillips* is that of claim differentiation. This canon states that claims should be interpreted so that each claim gets a meaning that is different from the meaning accorded to other claims; in other words, two different claims shouldn’t be

interpreted to cover exactly the same thing. Can you think of scenarios when it wouldn't make sense to apply this canon?

8. The dissent focuses on the factual nature of claim construction analysis. Is the dissent right to think of this as an essentially factual inquiry? If so, what does that tell you about the appropriate procedures and allocations of authority in claim construction? We will revisit this question, along with other procedural issues in claim construction, later in this chapter.

## 2. Special Kinds of Claims

Some claims are written in specialized formats that come with their own special rules of construction. This section focuses on two. First, is the means-plus-function claim, which is perhaps the most prominent specialized claim format. A means-plus-function claim permits a patentee to claim achieving a particular result without specifying in the claim the structures that achieve it. Second, a claim may be written in product-by-process form. This kind of claim is used to confine a patentee's rights to a process used for obtaining a specified product.

### a. Means-Plus-Function Claims

A means-plus-function claim specifies a particular function that must be performed; the specification then identifies the structures that perform that function. The construction of a means-plus-function term therefore (apparently) countenances greater reliance on the specification than the construction of an ordinary claim term. In a part of the *Phillips* opinion omitted from the main text above, the panel concluded that the relevant language in the claim did not trigger a "mean-plus-function" analysis. Here is the key portion of that analysis:

We agree with the panel that the term "baffles" is not means-plus-function language that invokes 35 U.S.C. § 112, ¶ 6. To be sure, the claim refers to "means disposed inside the shell for increasing its load bearing capacity," a formulation that would ordinarily be regarded as invoking the means-plus-function claim format. However, the claim specifically identifies "internal steel baffles" as structure that performs the recited function of increasing the shell's load-bearing capacity. In contrast to the "load bearing means" limitation, the reference to "baffles" does not use the word "means," and we have held that the absence of that term creates a rebuttable presumption that section 112, ¶ 6, does not apply.

Means-plus-function claiming applies only to purely functional limitations that do not provide the structure that performs the recited function. While the baffles in



## CLAIM CONSTRUCTION

the '798 patent are clearly intended to perform several functions, the term “baffles” is nonetheless structural; it is not a purely functional placeholder in which structure is filled in by the specification. The claims and the specification unmistakably establish that the “steel baffles” refer to particular physical apparatus. The claim characterizes the baffles as “extending inwardly” from the steel shell walls, which plainly implies that the baffles are structures. The specification likewise makes clear that the term “steel baffles” refers to particular internal wall structures and is not simply a general description of any structure that will perform a particular function. Because the term “baffles” is not subject to section 112, ¶ 6, we agree with the panel that the district court erred by limiting the term to corresponding structures disclosed in the specification and their equivalents. . . .

Why do you think the patent system includes this claim format? As you read the case below, think about whether the claim element at issue could have been written as an ordinary element, rather than as a means-plus-function element.



*Williamson v. Citrix Online, LLC*  
792 F.3d 1339 (Fed. Cir. 2015)

LINN, Circuit Judge.

Richard A. Williamson . . . owns U.S. Patent No. 6,155,840 and appeals from the stipulated final judgment in favor of defendants . . . . Because the district court correctly construed the limitation “distributed learning control module,” we affirm the judgment of invalidity of claims 8–12 of the '840 patent under 35 U.S.C. § 112, ¶ 2. . . .

I

A

The '840 patent describes methods and systems for “distributed learning” that utilize industry standard computer hardware and software linked by a network to provide a classroom or auditorium-like metaphor—i.e., a “virtual classroom” environment. The objective is to connect one or more presenters with geographically remote audience members. The disclosed inventions purport to provide “the benefits of classroom interaction without the detrimental effects of complicated hardware or software, or the costs and inconvenience of convening in a separate place.”

There are three main components of the “distributed learning” system set forth in the ‘840 patent: (1) a presenter computer, (2) audience member computers, and (3) a distributed learning server. The distributed learning server implements a “virtual classroom” over a computer network, such as the Internet, to facilitate communication and interaction among the presenter and audience members. The presenter computer is used by the presenter to communicate with the audience members and control information that appears on the audience member’s computer screen. An audience member’s computer is used to display the presentation and can be used to communicate with the presenter and other audience members.

The ‘840 patent includes the following [asserted claim], with disputed terms highlighted:

8. A system for conducting distributed learning among a plurality of computer systems coupled to a network, the system comprising:

a presenter computer system of the plurality of computer systems coupled to the network and comprising:

a content selection control . . . ; and

a presenter streaming data viewer . . . ;

an audience member computer system of the plurality of computer systems and coupled to the presenter computer system via the network, the audience member computer system comprising:

an audience member streaming data viewer . . . ; and

a distributed learning server remote from the presenter and audience member computer systems of the plurality of computer systems and coupled to the presenter computer system and the audience member computer system via the network and comprising:

a streaming data module for providing the streaming data from the remote streaming data source selected with the content selection control to the presenter and audience member computer systems; and

a *distributed learning control module* for receiving communications transmitted between the presenter and the audience member computer systems and for relaying the communications to an intended receiving computer system and for coordinating the operation of the streaming data module.

## CLAIM CONSTRUCTION

### II

#### A

Regarding questions of claim construction, including whether claim language invokes 35 U.S.C. § 112, ¶ 6, the district court's determinations based on evidence intrinsic to the patent as well as its ultimate interpretations of the patent claims are legal questions that we review de novo. . . .

#### C

##### *Applicability of 35 U.S.C. § 112, ¶ 6*

Means-plus-function claiming occurs when a claim term is drafted in a manner that invokes 35 U.S.C. § 112, ¶ 6, which states:

An element in a claim for a combination may be expressed as a means or step for performing a specified function without the recital of structure, material, or acts in support thereof, and such claim shall be construed to cover the corresponding structure, material, or acts described in the specification and equivalents thereof.

In enacting this provision, Congress struck a balance in allowing patentees to express a claim limitation by reciting a function to be performed . . . , while placing specific constraints on how such a limitation is to be construed, namely, by restricting the scope of coverage to only the structure, materials, or acts described in the specification as corresponding to the claimed function and equivalents thereof.

To determine whether § 112, ¶ 6 applies to a claim limitation, our precedent has long recognized the importance of the presence or absence of the word “means.” . . . [T]he use of the word “means” in a claim element creates a rebuttable presumption that § 112, ¶ 6 applies. Applying the converse, . . . the failure to use the word “means” also creates a rebuttable presumption—this time that § 112, ¶ 6 does not apply. We have not, however, blindly elevated form over substance . . . .

In making the assessment of whether the limitation in question is a means-plus-function term subject to the strictures of § 112, ¶ 6, our cases have emphasized that the essential inquiry is . . . whether the words of the claim are understood by persons of ordinary skill in the art to have a sufficiently definite meaning as the name for structure. . . .

In *Lighting World, Inc. v. Birchwood Lighting, Inc.*, 382 F.3d 1354, 1358 (Fed. Cir. 2004), we applied for the first time a different standard to the presumption flowing from the absence of the word “means” and held that “the presumption flowing from the absence of the term ‘means’ is a *strong one that is not readily overcome*,” . . . . In *Flo Healthcare Solutions, LLC v. Kappos*, 697 F.3d 1367, 1374 (Fed. Cir. 2012), . . . we raised the bar even

further, declaring that “when the claim drafter has not signaled his intent to invoke § 112, ¶ 6 by using the term ‘means,’ we are unwilling to apply that provision *without a showing that the limitation essentially is devoid of anything that can be construed as structure.*” Our opinions . . . have thus established a heightened bar to overcoming the presumption that a limitation expressed in functional language without using the word “means” is not subject to § 112, ¶ 6.

[We] conclude that such a heightened burden is unjustified and that we should abandon characterizing as “strong” the presumption that a limitation lacking the word “means” is not subject to § 112, ¶ 6. That characterization is unwarranted, is uncertain in meaning and application, and has the inappropriate practical effect of placing a thumb on what should otherwise be a balanced analytical scale. It has shifted the balance struck by Congress in passing § 112, ¶ 6 and has resulted in a proliferation of functional claiming untethered to § 112, ¶ 6 and free of the strictures set forth in the statute. Henceforth, we will apply the presumption . . . without requiring any heightened evidentiary showing and expressly overrule the characterization of that presumption as “strong.” We also overrule the strict requirement of “a showing that the limitation essentially is devoid of anything that can be construed as structure.”

The standard is whether the words of the claim are understood by persons of ordinary skill in the art to have a sufficiently definite meaning as the name for structure. When a claim term lacks the word “means,” the presumption can be overcome and § 112, ¶ 6 will apply if the challenger demonstrates that the claim term fails to “recite sufficiently definite structure” or else recites “function without reciting sufficient structure for performing that function.” The converse presumption remains unaffected: “use of the word ‘means’ creates a presumption that § 112, ¶ 6 applies.”

#### *Functional Nature of the Limitation*

We begin with the observation that the claim limitation in question is not merely the introductory phrase “distributed learning control module,” but the entire passage “distributed learning control module for receiving communications transmitted between the presenter and the audience member computer systems and for relaying the communications to an intended receiving computer system and for coordinating the operation of the streaming data module.” This passage, as lengthy as it is, is nonetheless in a format consistent with traditional means-plus-function claim limitations. It replaces the term “means” with the term “module” and recites three functions performed by the “distributed learning control module.”

“Module” is a well-known nonce word that can operate as a substitute for “means” in the context of § 112, ¶ 6. . . . “[M]odule’ is simply a generic description for software or hardware that performs a specified function.” Generic terms such as “mechanism,”

## CLAIM CONSTRUCTION

“element,” “device,” and other nonce words that reflect nothing more than verbal constructs may be used in a claim in a manner that is tantamount to using the word “means” because they “typically do not connote sufficiently definite structure” and therefore may invoke § 112, ¶ 6.

Here, the word “module” does not provide any indication of structure because it sets forth the same black box recitation of structure for providing the same specified function as if the term “means” had been used. Indeed, Williamson himself acknowledges that “the term ‘module,’ standing alone is capable of operating as a ‘nonce word’ substitute for ‘means.’”

The prefix “distributed learning control” does not impart structure into the term “module.” These words do not describe a sufficiently definite structure. Although the “distributed learning control module” is described in a certain level of detail in the written description, the written description fails to impart any structural significance to the term. At bottom, we find nothing in the specification or prosecution history that might lead us to construe that expression as the name of a sufficiently definite structure as to take the overall claim limitation out of the ambit of § 112, ¶ 6. While Williamson is correct that the presence of modifiers can change the meaning of “module,” the presence of these particular terms does not provide any structural significance to the term “module” in this case.

While portions of the claim do describe certain inputs and outputs at a very high level (e.g., communications between the presenter and audience member computer systems), the claim does not describe how the “distributed learning control module” interacts with other components in the distributed learning control server in a way that might inform the structural character of the limitation-in-question or otherwise impart structure to the “distributed learning control module” as recited in the claim.

### *Disclosure of Corresponding Structure*

Having found that the “distributed learning control module” is subject to . . . § 112, ¶ 6, we next determine whether the specification discloses sufficient structure that corresponds to the claimed function. We conclude that it does not.

Construing a means-plus-function claim term is a two-step process. The court must first identify the claimed function. Then, the court must determine what structure, if any, disclosed in the specification corresponds to the claimed function. Where there are multiple claimed functions, as we have here, the patentee must disclose adequate corresponding structure to perform all of the claimed functions. If the patentee fails to disclose adequate corresponding structure, the claim is indefinite.

The district court identified three claimed functions associated with the “distributed learning control module” term: (1) receiving communications transmitted between the presenter and the audience member computer systems; (2) relaying the communications to an intended receiving computer system; and (3) coordinating the operation of the streaming data module. The district court then found that the specification fails to disclose structure corresponding to the “coordinating” function. On appeal, it is undisputed that the claimed “coordinating” function is associated with the “distributed learning control module.” Thus, we must ascertain whether adequate structure corresponding to this function is disclosed in the specification.

Structure disclosed in the specification qualifies as “corresponding structure” if the intrinsic evidence clearly links or associates that structure to the function recited in the claim. Even if the specification discloses corresponding structure, the disclosure must be of “adequate” corresponding structure to achieve the claimed function. Under 35 U.S.C. § 112, ¶¶ 2 and 6, therefore, if a person of ordinary skill in the art would be unable to recognize the structure in the specification and associate it with the corresponding function in the claim, a means-plus-function clause is indefinite.

The . . . specification of the ’840 patent fails to disclose corresponding structure. The written description of the ’840 patent makes clear that the distributed learning control module cannot be implemented in a general purpose computer, but instead must be implemented in a special purpose computer—a general purpose computer programmed to perform particular functions pursuant to instructions from program software. A special purpose computer is required because the distributed learning control module has specialized functions as outlined in the written description. In cases such as this, involving a claim limitation that is subject to § 112, ¶ 6 that must be implemented in a special purpose computer, this court has consistently required that the structure disclosed in the specification be more than simply a general purpose computer or microprocessor. We require that the specification disclose an algorithm for performing the claimed function. The algorithm may be expressed as a mathematical formula, in prose, or as a flow chart, or in any other manner that provides sufficient structure.

Williamson points to certain disclosures in the specification that, it claims, meet the § 112, ¶ requirements. Williamson argues that the “distributed learning control module” controls communications among the various computer systems and that the “coordinating” function provides a presenter with streaming media selection functionality. These disclosures, however, are merely functions of the “distributed learning control module.” The specification does not set forth an algorithm for performing the claimed functions.

## CLAIM CONSTRUCTION

Williamson argues that figures 4 and 5 disclose the required algorithm. This is not the case. Figure 4 is a representative display from the presenter computer system under the direction of the “distributed learning control module.”

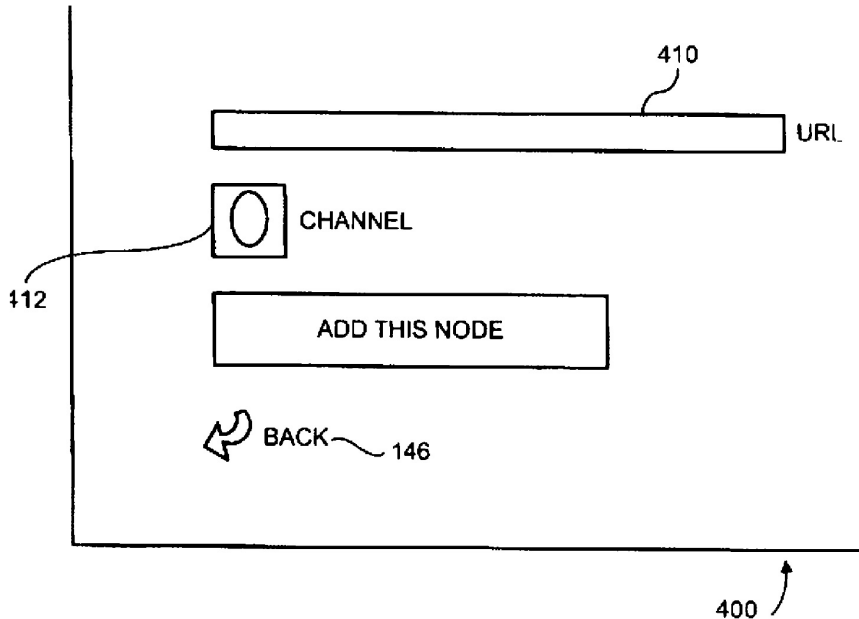

This display includes an address or uniform resource locator or URL field, a channel field, an “add this node” button, and a “back” link. This is not a disclosure of an algorithm corresponding to the claimed “coordinating” function; it is a description of a presenter display interface.

Figure 5 similarly fails to disclose an algorithm, as it is another representative display on the presenter computer system. This display allows the presenter to preview data before presenting it to the audience. This figure contains a box listing the sources of data and a media window that displays the current feed received from the source of data selected in the list box. Again, this figure is a description of a presenter display interface; it is not a disclosure of an algorithm corresponding to the claimed functions. . . .

Because the '840 patent fails to disclose any structure corresponding to the “coordinating” function of the “distributed learning control module,” we affirm the judgment that claims 8–16 are invalid for indefiniteness under 35 U.S.C. § 112, ¶ 2. . . .

## b. Product-by-Process Claims

*Abbott Laboratories v. Sandoz, Inc.*

566 F.3d 1282 (Fed. Cir. 2009)

RADER, Circuit Judge.

Abbott Laboratories . . . markets crystalline cefdinir according to the '507 patent under the trade name Omnicef. . . . Lupin's generic product contains almost exclusively the Crystal B form of crystalline cefdinir (cefдинir monohydrate), whereas Abbott's Omnicef product contains the Crystal A form of crystalline cefдинir (cefдинir anhydrate). Further, Lupin makes its products with processes other than those claimed in the '507 patent. For these reasons, Lupin brought the Virginia action to clarify that its proposed product would not infringe a valid patent. Abbott counterclaimed for infringement. . . .

[Abbott also sued Sandoz and Teva for infringement of the '507 patent in a parallel action in Illinois.]

Both cases arrived at this court on appeal. This court heard the cases together and decides them together with this decision.

## II

Claim 1 claims crystalline cefдинir, using its chemical name, and defining its unique characteristics with powder X-ray diffraction (PXRD) angle peaks:

1. Crystalline 7-[2-(2-a minothiazol-4-yl)-2-hydroxyiminoacetamido]-3-vinyl-3-cephem-4-carboxylic acid (syn isomer) which shows the peaks at the diffraction angles shown in the following table in its powder X-ray diffraction pattern:

diffraction angle (°)
about 14.7°
about 17.8°
about 21.5°
about 22.0°
about 23.4°
about 24.5°
about 28.1°

In contrast, claims 2–5 claim crystalline cefдинir, without any PXRD peak limitations, but with descriptions of processes used to obtain the crystalline cefдинir. Claims 2 and 5 are independent:



## CLAIM CONSTRUCTION

2. Crystalline 7-[2-(2-aminothiazol-4-yl)-2-hydroxyiminoacetamido]-3-vinyl-3-cephem-4-carboxylic acid (syn isomer) which is obtainable by acidifying a solution containing 7-[2-(2-aminothiazol-4-yl)-2-hydroxyiminoacetamido]-3-vinyl-3-cephem-4-carboxylic acid (syn isomer) at room temperature or under warming.

5. Crystalline 7-[2-(2-aminothiazol-4-yl)-2-hydroxyiminoacetamido]-3-vinyl-3-cephem-4-carboxylic acid (syn isomer) which is obtainable by dissolving 7-[2-(2-aminothiazol-4-yl)-2-hydroxyiminoacetamido]-3-vinyl-3-cephem-4-carboxylic acid (syn isomer) in an alcohol, continuing to stir the solution slowly under warming, then cooling the solution to room temperature and allowing the solution to stand.

These claims use PXRD as a way to claim the structure and characteristics of the unique crystalline form. PXRD is a method for identifying and distinguishing different crystalline compounds. The method beams X-rays toward a powdered chemical. The method then measures the ways the rays reflect or bend upon contact with the chemical. The diffraction angles and intensities vary with the type and purity of the test compound. A graph then plots the diffraction angle on one axis and the intensity on another. These graphs yield a unique “fingerprint” for each crystalline form of a chemical. A more sensitive form of X-ray diffraction is single crystal X-ray diffraction (SCXRD). As this name suggests, this method uses only a single crystal as a sample. SCXRD does not detect intensity, but produces a more precise diffraction angle measurement.

The '507 patent was not the first cefdinir patent. Rather, Astellas' prior art U.S. Patent No. 4,559,334 describes the discovery of cefdinir as a compound demonstrating high antimicrobial activity. The '334 patent expired on May 6, 2007.

The '507 patent claims priority to Japanese Patent Application No. 62-206199, which claimed two crystalline forms of cefdinir, “Crystal A” and “Crystal B.” The JP '199 application claimed Crystals A and B very specifically, defining Crystal A by three infrared (IR)-absorption wavelengths and sixteen PXRD angles and intensities. In contrast, Crystal B featured five IR-absorption wavelengths and twenty-one PXRD angles/intensities.

Despite using the JP '199 application for priority, the '507 patent's specification differs significantly. Specifically, Abbott . . . jettisoned the Crystal B disclosure found in the JP '199 application and crafted broader claims in its prosecution of the '507 patent. Because the JP '199 applications defines Crystal A and Crystal B physiochemically rather than structurally, the forms actually represent subgenres of crystalline cefdinir. Thus Crystals A and B comprise crystalline forms of varying structures, which in the context of this case means varying levels of hydration.

## III

Evaluation of a summary judgment of noninfringement requires two steps: claim construction, which this court reviews without deference, and comparison of the properly construed claims to the accused product, process, or composition of matter, which in the context of summary judgment also occurs without deference. Although infringement by equivalency is a question of fact, this court may affirm summary judgment “where no reasonable fact finder could find equivalence.”

1

[The court first concluded that the trial court properly limited “crystalline” in claims 1–5 to “Crystal A.”]

2

[Ed. note: The court, *sua sponte*, took *en banc* the issue of how to interpret product-by-process claims. Chief Judge Michel and Judges Rader, Bryson, Gajarsa, Linn, Dyk, Prost, and Moore joined this portion of the opinion.] Claims 2–5 of the ‘507 patent begin by reciting a product, crystalline cefdinir, and then recite a series of steps by which this product is “obtainable.” The Eastern District of Virginia correctly categorized claims 2–5 as product-by-process claims. On appeal, Abbott argues that the Eastern District erred in construing the process steps of claims 2–5 under the rule in *Atlantic Thermoplastics* that “process terms in product-by-process claims serve as limitations in determining infringement,” rather than in accordance with *Scripps Clinic & Research Foundation v. Genentech, Inc.* (“The correct reading of product-by-process claims is that they are not limited to product prepared by the process set forth in the claims.”). This court takes this opportunity to clarify *en banc* the scope of product-by-process claims by adopting the rule in *Atlantic Thermoplastics*.

In *Atlantic Thermoplastics*, this court considered the scope of product-by-process claim 26 in the patent at issue: “the molded innersole produced by the method of claim 1.” The patentee urged that competing, indistinguishable innersoles made by a different method nonetheless infringed claim 26. This court rejected the patentee’s position [and] construed product-by-process claims as limited by the process.

...

The Supreme Court has long emphasized the limiting requirement of process steps in product-by-process claims. In *BASF*, the Court considered a patent [that] claimed “artificial alizarine, produced from anthracine or its derivatives by either of the methods herein described, or by any other method which will produce a like result.” In turn, the specification generally described a method for making artificial alizarine involving anthracine or its derivatives. Alizarine had been in use for thousands of years as a red

## CLAIM CONSTRUCTION

textile dye, traditionally extracted from madder root. Pure alizarine has the chemical formula  $C_{14}H_8O_4$ , but “artificial alizarines” available in the market at the time of the litigation varied from almost completely pure alizarine, to combinations of alizarine and anthrapurpurine, to pure purpurine containing no alizarine whatsoever. The defendant’s product contained approximately sixty percent anthrapurpurine. Thus both alizarine and artificial alizarines were known in the prior art. The Supreme Court clearly articulated some of the scope and validity problems that arise when process limitations of product-by-process claims are ignored:

[The defendant’s product] is claimed by the plaintiff to be the artificial alizarine described in No. 4,321, and to be physically, chemically, and in coloring properties similar to that. But what that is is not defined in No. 4,321, except that it is the product of the process described in No. 4,321. Therefore, unless it is shown that the process of No. 4,321 was followed to produce the defendant’s article, or unless it is shown that that article could not be produced by any other process, the defendant’s article cannot be identified as the product of the process of No. 4,321. Nothing of the kind is shown.

If the words of the claim are to be construed to cover all artificial alizarine, whatever its ingredients, produced from anthracine or its derivatives by methods invented since Graebe and Liebermann invented the bromine process, we then have a patent for a product or composition of matter which gives no information as to how it is to be identified. *Every patent for a product or composition of matter must identify it so that it can be recognized aside from the description of the process for making it, or else nothing can be held to infringe the patent which is not made by that process.*

...

Thus, . . . this court now restates that “process terms in product-by-process claims serve as limitations in determining infringement.” . . . [T]his holding follows this court’s clear statement in *In re Thorpe* that “product by process claims are limited by and defined by the process.”

More recently, the Supreme Court has reiterated the broad principle that “each element contained in a patent claim is deemed material to defining the scope of the patented invention.” Although *Warner–Jenkinson* specifically addressed the doctrine of equivalents, this rule applies to claim construction overall. As applied to product-by-process claims, *Warner–Jenkinson* thus reinforces the basic rule that the process terms limit product-by-process claims. To the extent that *Scripps Clinic* is inconsistent with this rule, this court hereby expressly overrules *Scripps Clinic*.

The dissenting opinions lament the loss of a “right” that has never existed in practice or precedent—the right to assert a product-by-process claim against a defendant who does

not practice the express limitations of the claim. This court's *en banc* decision in no way abridges an inventor's right to stake claims in product-by-process terms. Instead this decision merely restates the rule that the defining limitations of a claim—in this case process terms—are also the terms that show infringement.

Thus this court does not question at all whether product-by-process claims are legitimate as a matter of form. The legitimacy of this claim form was indeed a relevant issue in the nineteenth century . . . [h]owever, this court need not address that settled issue. The issue here is only whether such a claim is infringed by products made by processes other than the one claimed. This court holds that it is not.

...

Product-by-process claims, especially for those rare situations when products were difficult or impossible to describe, historically presented a concern that the Patent Office might deny *all* product protection to such claims. In the modern context, however, if an inventor invents a product whose structure is either not fully known or too complex to analyze . . . , this court clarifies that the inventor is absolutely free to use process steps to define this product. The patent will issue subject to the ordinary requirements of patentability. The inventor will not be denied protection. Because the inventor chose to claim the product in terms of its process, however, that definition also governs the enforcement of the bounds of the patent right. This court cannot simply ignore as verbiage the only definition supplied by the inventor.

This court's rule regarding the proper treatment of product-by-process claims in infringement litigation carries its own simple logic. Assume a hypothetical chemical compound defined by process terms. The inventor declines to state any structures or characteristics of this compound. The inventor of this compound obtains a product-by-process claim: "Compound X, obtained by process Y." Enforcing this claim without reference to its defining terms would mean that an alleged infringer who produces compound X by process Z is still liable for infringement. But how would the courts ascertain that the alleged infringer's compound is really the same as the patented compound? After all, the patent holder has just informed the public and claimed the new product solely in terms of a single process. Furthermore, what analytical tools can confirm that the alleged infringer's compound is in fact infringing, other than a comparison of the claimed and accused infringing processes? If the basis of infringement is not the similarity of process, it can only be similarity of structure or characteristics, which the inventor has not disclosed. Why also would the courts deny others the right to freely practice process Z that may produce a better product in a better way?

In sum, it is both unnecessary and logically unsound to create a rule that the process limitations of a product-by-process claim should not be enforced in some exceptional

## CLAIM CONSTRUCTION

instance when the structure of the claimed product is unknown and the product can be defined only by reference to a process by which it can be made. Such a rule would expand the protection of the patent beyond the subject matter that the inventor has “particularly pointed out and distinctly claimed” as his invention.

3

In this case, Abbott’s plain language argument, that “*obtainable by*” introduces an optional process, even if “*obtained by*” would introduce limiting process steps, is also unavailing. The *BASF* case, an analogous situation to this case, controls. . . . [The] Supreme Court in *BASF* considered the following claim language: “Artificial alizarine, produced from anthracine or its derivatives by either of the methods herein described, *or by any other method which will produce a like result.*” The patentee argued that even though the defendant did not make artificial alizarine by “either of the methods herein described,” the claim should capture the product because of the “or by another method” language. The Supreme Court refused to attach importance to those expansive words: “No. 4,321 furnishes no test by which to identify the product it covers, except that such product is to be the result of the process it describes.” Abbott’s claims 2–5, like those in *BASF* and like product-by-process claims in general, do not furnish any test by which to identify the cefdinir crystals except that they are the result of their respectively claimed processes. As per *BASF*, Abbott’s claim cannot capture a product obtained by or obtainable by processes other than those explicitly recited in the claims.

If this court were to strip the process elements from the claims, as Abbott would urge, for infringement purposes, there would then be nothing to differentiate independent claim 2 from independent claim 5. After all, if those claims are not bound by the process terms but only “define” the basic cefdinir compound, then each of the claims recite the same thing, over and over again. Though Abbott argues that it merely intends to give meaning to the word “obtainable,” it instead seeks to have this court render meaningless the explicit process limitations that the applicant chose to define its invention.

The intrinsic evidence in this case further rebuts Abbott’s contention . . . . In column 2 of the ’507 patent, under the title heading “The Process for Preparing Crystal A of the Compound (I),” the patentee used specific language to describe the very two processes that are mirrored in claims 2 and 5. This language is not open-ended, nor does it constitute a mere description of the product by reference to the manner in which it can be made . . . . By drafting claims 2 and 5 to incorporate these specific processes, Abbott made a conscious choice to place process requirements on its claimed product. If Abbott had wanted to obtain broader coverage for crystalline cefdinir devoid of any process limitations . . . , it could have simply done so (if . . . it is really the product that is the heart of the invention, not the process). But it did not. The crystals of claims 2 and 5 are simply

not identifiable other than by the processes disclosed in column 2. This court must enforce the ways and terms that a party chooses to define its invention.

The prosecution history also does not support Abbott's contention that "obtainable by" offers merely an optional set of definitional process conditions. During prosecution, Abbott faced obviousness rejections based on application claims 6–9, which were process claims that mirrored the *very* process limitations of issued claims 2–5. The PTO refused to issue the claims until one set of duplicates was cancelled. Abbott's action in cancelling claims 6–9 demonstrates its acquiescence to the PTO's view that the process elements of claims 2–5 are critical parts of those claims. In addition, in a response to the PTO's office action, Abbott chose to differentiate a cited § 103 reference, Takaya, on the basis that Abbott's claimed processes are different. For these reasons, the applicant's statement in the file wrapper that "the method of preparation . . . is not considered the heart of the present invention" should not be afforded undue gravitas. The process limitations cannot be haphazardly jettisoned for an infringement analysis when they were so important in the patentability analysis.

In sum, a patentee's use of the word "obtainable" rather than "obtained by" cannot give it a free pass to escape the ambit of the product-by-process claiming doctrine. Claims that include such ambiguous language should be viewed extremely narrowly. If this court does not require, as a precondition for infringement, that an accused infringer actually use a recited process, simply because of the patentee's choice of the probabilistic suffix "able," the very recitation of that process becomes redundant. This would widen the scope of the patentee's claims beyond that which is actually invented—a windfall to the inventor at the expense of future innovation and proper notice to the public of the scope of the claimed invention. For all the above reasons, the [trial court] correctly construed the process limitations beginning with "obtainable by" in claims 2–5 as limiting the asserted claims to products made by those process steps.

NEWMAN, Circuit Judge, with whom Circuit Judges MAYER and LOURIE join, dissenting from *en banc* Section III.A.2.

The court today acts *en banc* to overturn a century of precedent and practice, and holds that a new product that is difficult to describe without reference to how it was made, but that is nonetheless a new and unobvious product, cannot be protected as a product if its description is aided by reference to how it was made. Heretofore a new product whose structure was not fully known or not readily described could be patented as a product by including in the product description sufficient reference to how it can be made, to distinguish the new product from prior art products. Patentability was determined as a product, independent of any process reference in the claim, and validity and infringement were based on the product itself. This expedient for patenting products whose structure was not fully known at the time of filing the patent application has been called the "rule

## CLAIM CONSTRUCTION

of necessity.” It was pragmatic, fair, and just, for it attuned patent law and practice to the realities of invention.

Today the court rejects this expedient and discards this practice, ruling that all claims containing a process term under the rule of necessity now must be construed, for purposes of infringement, as limited to use of any process term that was used to assist in defining the product. That is, such a product is not patented as a product, however it is produced, but is limited to the process by which it was obtained. This is a new restraint on patents for new products, particularly today’s complex chemical and biological products whose structure may be difficult to analyze with precision. It is a change of law with unknown consequences for patent-based innovation.

LOURIE, Circuit Judge, dissenting from *en banc* Section III.A.2.

I respectfully dissent from the court’s *en banc* holding in Section III.A.2 that product-by-process claims always require use of the recited process in order to be infringed.

I agree that there is substantial Supreme Court precedent that holds that product-by-process claims require use of the recited process for there to be infringement. However, many of those cases applied overly broad language to fact situations involving old products or used vague language that makes it difficult to determine whether the products were old or new. Clearly, however, when a product is old, a product-by-process claim cannot be interpreted as a claim to the product made by any means. The product is old and unpatentable *per se*. *BASF* in fact involved an old product.

There is arguably a different situation that should apply to chemical-biological products today than to mechanical products of more than a century ago. When a product is new and the inventor claims it by a process of preparation, I fail to see why the product-by-process claim should not be interpreted as a product claim that can be infringed even when the product is made by means other than that recited in the claim. . . . The Court years ago did not have occasion to consider today’s innovations or decide whether a distinction should be made between a new chemical-biological product and an old product made by a new process.

And there may be differing results depending upon the exact wording of a claim at issue. For example, a claim reading “when made by” might only be infringed when the recited process is used by the accused, as it is situational. On the other hand, a claim reading “obtainable by” refers to capability, so it might not require use of the process to infringe. “Obtained by” is ambiguous. Bright lines have their uses, but judging should take account of differing circumstances. In addition, of course, in order to sustain any claim for infringement, a patent owner must prove that an accused product is the same as that covered by an asserted claim. If the reason a product was claimed by its process was that its structure was unknown, then, if, at the time infringement is asserted, there still is

no means to ascertain structurally whether the accused product is the same as that claimed, the infringement claim fails. However, that should not mean that a new product claimed by a process of preparation cannot ever be infringed when made by another process.

It may be that with today's analytical techniques there is little need for product-by-process claims. After all, claim 1 of the Abbott patent is a claim to a compound, not only by name, but also by certain of its characteristics. A claim to a product defined by its characteristics or properties surely is a proper claim.

However, product-by-process issues still seem to come before us and I would make a distinction between old products and new products in interpreting product-by-process claims. Accordingly, I respectfully dissent from the court's *en banc* holding.

## B. Institutional Dimensions of Claim Construction

Claim construction raises an array of difficult questions regarding the allocation of authority between judges and juries, trial courts and appellate courts, and the judicial and executive branches. These questions have taken their turn in the patent system's spotlight. In this section, we will explore how each of those questions have been resolved and the impact they have had on patent process.

### *Markman v. Westview Instruments, Inc.* 517 U.S. 370 (1996)

Justice SOUTER delivered the opinion of the Court.

The question here is whether the interpretation of a so-called patent claim, the portion of the patent document that defines the scope of the patentee's rights, is a matter of law reserved entirely for the court, or subject to a Seventh Amendment guarantee that a jury will determine the meaning of any disputed term of art about which expert testimony is offered. We hold that the construction of a patent, including terms of art within its claim, is exclusively within the province of the court.

#### I

[A] patent must describe the exact scope of an invention and its manufacture to "secure to the patentee all to which he is entitled, and to apprise the public of what is still open to them." . . . [T]hese objectives are served by two distinct elements of a patent document. First, it contains a specification describing the invention "in such full, clear, concise, and exact terms as to enable any person skilled in the art . . . to make and use the same." 35 U.S.C. § 112. Second, a patent includes one or more "claims," which



## CLAIM CONSTRUCTION

“particularly point out and distinctly claim the subject matter which the applicant regards as his invention.” *Id.* . . . The claim “defines the scope of a patent grant,” and functions to forbid not only exact copies of an invention, but products that go to “the heart of an invention but avoids the literal language of the claim by making a noncritical change.” . . .

Characteristically, patent lawsuits charge what is known as infringement, and rest on allegations that the defendant “without authority made, used or sold the patented invention” . . . . Victory in an infringement suit requires a finding that the patent claim “covers the alleged infringer’s product or process,” which in turn necessitates a determination of “what the words in the claim mean.”

Petitioner in this infringement suit, Markman, owns United States Reissue Patent No. 33,054 for his “Inventory Control and Reporting System for Drycleaning Stores.” The patent describes a system that can monitor and report the status, location, and movement of clothing in a dry-cleaning establishment. . . .

Part of the dispute hinged upon the meaning of the word “inventory,” a term found in Markman’s independent claim 1, which states that Markman’s product can “maintain an inventory total” and “detect and localize spurious additions to inventory.” The case was tried before a jury, which heard, among others, a witness produced by Markman who testified about the meaning of the claim language.

After the jury compared the patent to Westview’s device, it found an infringement of Markman’s independent claim 1 and dependent claim 10. The District Court nevertheless granted Westview’s deferred motion for judgment as a matter of law, one of its reasons being that the term “inventory” in Markman’s patent encompasses “both cash inventory and the actual physical inventory of articles of clothing.” Under the trial court’s construction of the patent, . . . a tracking system for dry cleaners would not infringe Markman’s patent unless the product was capable of tracking articles of clothing throughout the cleaning process and generating reports about their status and location. . . . [T]he District Court directed a verdict on the ground that Westview’s device does not have the “means to maintain an inventory total” and thus cannot “detect and localize spurious additions to inventory as well as spurious deletions therefrom” . . . .

Markman appealed, arguing it was error for the District Court to substitute its construction of the disputed claim term “inventory” for the construction the jury had presumably given it. The United States Court of Appeals for the Federal Circuit affirmed, holding the interpretation of claim terms to be the exclusive province of the court and the Seventh Amendment to be consistent with that conclusion. Markman sought our review on each point, and we granted certiorari. We now affirm.

## CHAPTER 8

### II

The Seventh Amendment provides that “in Suits at common law, where the value in controversy shall exceed twenty dollars, the right of trial by jury shall be preserved . . . .” Since Justice Story’s day, we have understood that “the right of trial by jury thus preserved is the right which existed under the English common law when the Amendment was adopted.” In keeping with our longstanding adherence to this “historical test,” we ask, first, whether we are dealing with a cause of action that either was tried at law at the time of the founding or is at least analogous to one that was. If the action in question belongs in the law category, we then ask whether the particular trial decision must fall to the jury in order to preserve the substance of the common-law right as it existed in 1791.

### A

As to the first issue, . . . “our analysis is familiar. First we compare the statutory action to 18th-century actions brought in the courts of England prior to the merger of the courts of law and equity.” Equally familiar is the descent of today’s patent infringement action from the infringement actions tried at law in the 18th century, and there is no dispute that infringement cases today must be tried to a jury . . . .

### B

This conclusion raises the second question, whether a particular issue occurring within a jury trial (here the construction of a patent claim) is itself necessarily a jury issue, the guarantee being essential to preserve the right to a jury’s resolution of the ultimate dispute. In some instances the answer to this second question may be easy because of clear historical evidence that the very subsidiary question was so regarded under the English practice of leaving the issue for a jury. But when, as here, the old practice provides no clear answer, we are forced to make a judgment about the scope of the Seventh Amendment guarantee without the benefit of any foolproof test.

The . . . answer to the second question “must depend on whether the jury must shoulder this responsibility *as necessary to preserve the substance of the common-law right of trial by jury.*” “Only those incidents which are regarded as fundamental, as inherent in and of the essence of the system of trial by jury, are placed beyond the reach of the legislature.”

The “substance of the common-law right” is, however, a pretty blunt instrument for drawing distinctions. We have tried to sharpen it, to be sure, by reference to the distinction between substance and procedure. We have also spoken of the line as one between issues of fact and law.

## CLAIM CONSTRUCTION

But the sounder course, when available, is to classify a mongrel practice (like construing a term of art following receipt of evidence) by using the historical method, much as we do in characterizing the suits and actions within which they arise. Where there is no exact antecedent, the best hope lies in comparing the modern practice to earlier ones whose allocation to court or jury we do know, seeking the best analogy we can draw between an old and the new.

### C

“Prior to 1790 nothing in the nature of a claim had appeared either in British patent practice or in that of the American states,” and we have accordingly found no direct antecedent of modern claim construction in the historical sources. Claim practice did not achieve statutory recognition until the passage of the Act of July 4, 1836, ch. 357, § 6, 5 Stat. 119, and inclusion of a claim did not become a statutory requirement until 1870, Act of July 8, 1870, ch. 230, § 26, 16 Stat. 201. Although, as one historian has observed, as early as 1850 “judges were . . . beginning to express more frequently the idea that in seeking to ascertain the invention ‘claimed’ in a patent the inquiry should be limited to interpreting the summary, or ‘claim,’ the idea that the claim is just as important if not more important than the description and drawings did not develop until the Act of 1870 or thereabouts.”

At the time relevant for Seventh Amendment analogies, in contrast, it was the specification, itself a relatively new development, that represented the key to the patent. Thus, patent litigation in that early period was typified by so-called novelty actions, testing whether “any essential part of the patent had been disclosed to the public before,” and “enablement” cases, in which juries were asked to determine whether the specification described the invention well enough to allow members of the appropriate trade to reproduce it.

The closest 18th-century analogue of modern claim construction seems, then, to have been the construction of specifications, and as to that function the mere smattering of patent cases that we have from this period shows no established jury practice sufficient to support an argument by analogy that today’s construction of a claim should be a guaranteed jury issue. Few of the case reports even touch upon the proper interpretation of disputed terms in the specifications at issue, and none demonstrates that the definition of such a term was determined by the jury. This absence of an established practice should not surprise us, given the primitive state of jury patent practice at the end of the 18th century . . . . Although by 1791 more than a century had passed since the enactment of the Statute of Monopolies, which provided that the validity of any monopoly should be determined in accordance with the common law, patent litigation had remained within the jurisdiction of the Privy Council until 1752 and hence without the option of a jury trial. Indeed, the state of patent law in the common-law courts before 1800 led one historian to observe that “the reported cases are destitute of any decision of importance . . . . At the

end of the eighteenth century, therefore, the Common Law Judges were left to pick up the threads of the principles of law without the aid of recent and reliable precedents." Earlier writers expressed similar discouragement at patent law's amorphous character, and, as late as the 1830's, English commentators were irked by enduring confusion in the field.

Markman seeks to supply what the early case reports lack in so many words by . . . arguing that the 18th-century juries must have acted as definers of patent terms just to reach the verdicts we know they rendered in patent cases turning on enablement or novelty. But the conclusion simply does not follow. There is no more reason to infer that juries supplied plenary interpretation of written instruments in patent litigation than in other cases implicating the meaning of documentary terms, and we do know that in other kinds of cases during this period judges, not juries, ordinarily construed written documents.

The probability that the judges were doing the same thing in the patent litigation of the time is confirmed by the fact that as soon as the English reports did begin to describe the construction of patent documents, they show the judges construing the terms of the specifications. This evidence is in fact buttressed by cases from this Court; when they first reveal actual practice, the practice revealed is of the judge construing the patent. *See, e.g., Winans v. Denmead*, 15 How. 330, 338 (1854). These indications of our patent practice are the more impressive for being all of a piece with what we know about the analogous contemporary practice of interpreting terms within a land patent, where it fell to the judge, not the jury, to construe the words.

#### D

Losing, then, on the contention that juries generally had interpretive responsibilities during the 18th century, Markman seeks a different anchor for analogy in the more modest contention that even if judges were charged with construing most terms in the patent, the art of defining terms of art employed in a specification fell within the province of the jury. Again, however, Markman has no authority from the period in question, but relies instead on the later case of *Neilson v. Harford*, Webs. Pat. Cas. 328 (Exch. 1841). There, an exchange between the judge and the lawyers indicated that although the construction of a patent was ordinarily for the court, judges should "leave the question of words of art to the jury." . . . [T]he most we can say is that an English report more than 70 years after the time that concerns us indicates an exception to what probably had been occurring earlier. In place of Markman's inference that this exceptional practice existed in 1791 there is at best only a possibility that it did, and for anything more than a possibility we have found no scholarly authority.

## CLAIM CONSTRUCTION

### III

Since evidence of common-law practice at the time of the framing does not entail application of the Seventh Amendment's jury guarantee to the construction of the claim document, we must look elsewhere to characterize this determination of meaning in order to allocate it as between court or jury. We accordingly consult existing precedent and consider both the relative interpretive skills of judges and juries and the statutory policies that ought to be furthered by the allocation.

#### A

The two elements of a simple patent case, construing the patent and determining whether infringement occurred, were characterized by the former patent practitioner, Justice Curtis. "The first is a question of law, to be determined by the court, construing the letters-patent, and the description of the invention and specification of claim annexed to them. The second is a question of fact, to be submitted to a jury."

In arguing for a different allocation of responsibility for the first question, *Markman* relies primarily on two cases . . . said to show that evidence of the meaning of patent terms was offered to 19th-century juries, and thus to imply that the meaning of a documentary term was a jury issue whenever it was subject to evidentiary proof. That is not what *Markman's* cases show, however.

. . .

*Bischoff* [v. *Wethered*, 9 Wall. 812 (1870)] does not . . . hold that the use of expert testimony about the meaning of terms of art requires the judge to submit the question of their construction to the jury. It is instead a case in which the Court drew a line between issues of document interpretation and product identification, and held that expert testimony was properly presented to the jury on the latter, ultimate issue . . . . The Court did not see the decision as bearing upon the appropriate treatment of disputed terms. As the opinion emphasized, the Court's "view of the case is not intended to, and does not, trench upon the doctrine that the construction of written instruments is the province of the court alone. *It is not the construction of the instrument, but the character of the thing invented, which is sought in questions of identity and diversity of inventions.*" . . .

If the line drawn . . . is a fine one, it is one that the Court has drawn repeatedly in explaining the respective roles of the jury and judge in patent cases, and one understood by commentators writing in the aftermath of the cases *Markman* cites. Walker, for example, read *Bischoff* as holding that the question of novelty is not decided by a construction of the prior patent, "but depends rather upon the outward embodiment of the terms contained in the prior patent; and that such outward embodiment is to be properly sought, like the explanation of latent ambiguities arising from the description of

external things, by evidence *in pais*." He also emphasized in the same treatise that matters of claim construction, even those aided by expert testimony, are questions for the court:

Questions of construction are questions of law for the judge, not questions of fact for the jury. As it cannot be expected, however, that judges will always possess the requisite knowledge of the meaning of the terms of art or science used in letters patent, it often becomes necessary that they should avail themselves of the light furnished by experts relevant to the significance of such words and phrases. The judges are not, however, obliged to blindly follow such testimony.

Virtually the same description of the court's use of evidence in its interpretive role was set out in another contemporary treatise:

The duty of interpreting letters-patent has been committed to the courts. A patent is a legal instrument, to be construed, like other legal instruments, according to its tenor. . . . Where technical terms are used, or where the qualities of substances or operations mentioned or any similar data necessary to the comprehension of the language of the patent are unknown to the judge, the testimony of witnesses may be received upon these subjects, and any other means of information be employed. *But in the actual interpretation of the patent the court proceeds upon its own responsibility, as an arbiter of the law, giving to the patent its true and final character and force.*

## B

Where history and precedent provide no clear answers, functional considerations also play their part in the choice between judge and jury to define terms of art. . . . [W]hen an issue "falls somewhere between a pristine legal standard and a simple historical fact, the fact/law distinction at times has turned on a determination that, as a matter of the sound administration of justice, one judicial actor is better positioned than another to decide the issue in question." So it turns out here, for judges, not juries, are the better suited to find the acquired meaning of patent terms.

The construction of written instruments is one of those things that judges often do and are likely to do better than jurors unburdened by training in exegesis. Patent construction in particular "is a special occupation, requiring, like all others, special training and practice. The judge, from his training and discipline, is more likely to give a proper interpretation to such instruments than a jury; and he is, therefore, more likely to be right, in performing such a duty, than a jury can be expected to be." Such was the understanding nearly a century and a half ago, and there is no reason to weigh the respective strengths of judge and jury differently in relation to the modern claim; quite the contrary, for "the claims of patents have become highly technical in many respects as

## CLAIM CONSTRUCTION

the result of special doctrines relating to the proper form and scope of claims that have been developed by the courts and the Patent Office.”

Markman would trump these considerations with his argument that a jury should decide a question of meaning peculiar to a trade or profession simply because the question is a subject of testimony requiring credibility determinations, which are the jury’s forte. It is, of course, true that credibility judgments have to be made about the experts who testify in patent cases, and in theory there could be a case in which a simple credibility judgment would suffice to choose between experts whose testimony was equally consistent with a patent’s internal logic. But our own experience with document construction leaves us doubtful that trial courts will run into many cases like that. In the main, we expect, any credibility determinations will be subsumed within the necessarily sophisticated analysis of the whole document, required by the standard construction rule that a term can be defined only in a way that comports with the instrument as a whole. Thus, in these cases a jury’s capabilities to evaluate demeanor, to sense the “mainsprings of human conduct,” or to reflect community standards, are much less significant than a trained ability to evaluate the testimony in relation to the overall structure of the patent. The decisionmaker vested with the task of construing the patent is in the better position to ascertain whether an expert’s proposed definition fully comports with the specification and claims and so will preserve the patent’s internal coherence. We accordingly think there is sufficient reason to treat construction of terms of art like many other responsibilities that we cede to a judge in the normal course of trial, notwithstanding its evidentiary underpinnings.

### C

Finally, we see the importance of uniformity in the treatment of a given patent as an independent reason to allocate all issues of construction to the court. “The limits of a patent must be known for the protection of the patentee, the encouragement of the inventive genius of others and the assurance that the subject of the patent will be dedicated ultimately to the public.” Otherwise, a “zone of uncertainty which enterprise and experimentation may enter only at the risk of infringement claims would discourage invention only a little less than unequivocal foreclosure of the field,” and “the public [would] be deprived of rights supposed to belong to it, without being clearly told what it is that limits these rights.” It was just for the sake of such desirable uniformity that Congress created the Court of Appeals for the Federal Circuit as an exclusive appellate court for patent cases, observing that increased uniformity would “strengthen the United States patent system in such a way as to foster technological growth and industrial innovation.”

Uniformity would, however, be ill served by submitting issues of document construction to juries. Making them jury issues would not, to be sure, necessarily leave evidentiary questions of meaning wide open in every new court in which a patent might

be litigated, for principles of issue preclusion would ordinarily foster uniformity. But whereas issue preclusion could not be asserted against new and independent infringement defendants even within a given jurisdiction, treating interpretive issues as purely legal will promote (though it will not guarantee) intrajurisdictional certainty through the application of *stare decisis* on those questions not yet subject to interjurisdictional uniformity under the authority of the single appeals court.

Accordingly, we hold that the interpretation of the word “inventory” in this case is an issue for the judge, not the jury, and affirm the decision of the Court of Appeals for the Federal Circuit.

### Context and Application

1. The *Markman* decision proved to be enormously consequential. Because the interpretation of patent claims was deemed to be the responsibility of judges, not juries, patent litigants began regularly filing pre-trial motions asking for a resolution of these disputes regarding claim language. Hearings of those motions, which are known as *Markman* hearings or claim construction hearings, frequently determine the outcome of the infringement lawsuit; once the meaning of the claim terms is set, the parties often come to an agreement on whether there has been infringement and what, if anything, an appropriate settlement would look like. See Lee Petherbridge & R. Polk Wagner, *Teva and the Process of Claim Construction*, 70 FLA. L. REV. 379, 385 (2018) (describing claim construction as “the dispositive issue in the overwhelming majority of cases”). District courts that hear large numbers of patent cases have developed local rules regarding the timing and procedure of these hearings. See, e.g., N.D. Cal. Patent Local Rules; see also *O2 Micro Int’l Ltd. v. Monolithic Power Systems, Inc.* 467 F.3d 1355 (Fed. Cir. 2006) (affirming the Northern District of California’s reliance on local patent rules). Savvy patent litigators focus intently on those local rules as part of the selection of a forum.

2. Is this any way to decide whether a judge or jury should resolve disputes about claim language? How valuable are those historical practices and analogies in light of the significant changes to the patent system, including the introduction of the claims themselves? How persuasive are the Court’s assessments of the functional considerations? See J. Jonas Anderson & Peter S. Menell, *Informal Deference: A Historical, Empirical, and Normative Analysis of Patent Claim Construction*, 108 NW. L. REV. 1 (2014) (demonstrating that the rate at which the Federal Circuit reversed district court claim construction decisions was as high as 44% in the year before *Phillips* was decided, and as low as 16.5% in 2009).

3. Even if there is no Seventh Amendment right to have a jury resolve questions of claim construction, Congress could mandate by statute that juries do so. Should it? Note



## CLAIM CONSTRUCTION

that in one area of patent litigation—Hatch-Waxman disputes involving applications to manufacture generic version of patented pharmaceuticals—judges resolve all questions of validity and infringement without a jury because the statute governing those disputes provides for only equitable claims for relief. *See* 35 U.S.C. § 271(e); *Sanofi-Synthelabo v. Apotex, Inc.*, 2002 WL 1917871 (S.D.N.Y. 2002).

4. Although *Markman* settled the question who between judges and juries has responsibility for claim construction, other questions persisted. Among the most prominent ones was whether claim construction ought to be reviewed by an appellate court as a factual decision for clear error or as a legal decision *de novo*. The Supreme Court took up that question in the following case. Before you read it, though, what do you think about whether these decisions should be reviewed for clear error or *de novo*?

### *Teva Pharmaceuticals, Inc. v. Sandoz, Inc.*

574 U.S. 318 (2015)

Justice BREYER delivered the opinion of the Court.

Today’s case involves claim construction with “evidentiary underpinnings.” And, it requires us to determine what standard the Court of Appeals should use when it reviews a trial judge’s resolution of an underlying factual dispute. . . .

## II

### A

Federal Rule of Civil Procedure 52(a)(6) states that a court of appeals “must not . . . set aside” a district court’s “findings of fact” unless they are “clearly erroneous.” In our view, this rule and the standard it sets forth must apply when a court of appeals reviews a district court’s resolution of subsidiary factual matters made in the course of its construction of a patent claim. We have made clear that the Rule sets forth a “clear command.” “It does not make exceptions or purport to exclude certain categories of factual findings from the obligation of a court of appeals to accept a district court’s findings unless clearly erroneous.” Accordingly, the Rule applies to both subsidiary and ultimate facts. And we have said that, when reviewing the findings of a “district court sitting without a jury, appellate courts must constantly have in mind that their function is not to decide factual issues *de novo*.”

. . .

Our opinion in *Markman* neither created, nor argued for, an exception to Rule 52(a). The question presented in that case was a Seventh Amendment question: Should a jury or a judge construe patent claims? We pointed out that history provides no clear answer.

The task primarily involves the construction of written instruments. And that task is better matched to a judge's skills. We consequently held that claim construction falls "exclusively within the province of the court," not that of the jury.

When describing claim construction we concluded that it was proper to treat the ultimate question of the proper construction of the patent as a question of law in the way that we treat document construction as a question of law. But this does not imply an exception to Rule 52(a) for underlying factual disputes. We used the term "question of law" while pointing out that a judge, in construing a patent claim, is engaged in much the same task as the judge would be in construing other written instruments, such as deeds, contracts, or tariffs. Construction of written instruments often presents a "question solely of law," at least when the words in those instruments are "used in their ordinary meaning." But sometimes, say, when a written instrument uses "technical words or phrases not commonly understood," those words may give rise to a factual dispute. If so, extrinsic evidence may help to "establish a usage of trade or locality." And in that circumstance, the "determination of the matter of fact" will "precede" the "function of construction." This factual determination, like all other factual determinations, must be reviewed for clear error.

[*Markman*] did not create an exception from the ordinary rule governing appellate review of factual matters. . . . A conclusion that an issue is for the judge does not indicate that Rule 52(a) is inapplicable.

While we held in *Markman* that the ultimate issue of the proper construction of a claim should be treated as a question of law, we also recognized that in patent construction, subsidiary factfinding is sometimes necessary. Indeed, we referred to claim construction as a practice with "evidentiary underpinnings," a practice that "falls somewhere between a pristine legal standard and a simple historical fact." We added that sometimes courts may have to make "credibility judgments" about witnesses. In other words, we recognized that courts may have to resolve subsidiary factual disputes. And . . . the Rule requires appellate courts to review all such subsidiary factual findings under the "clearly erroneous" standard.

. . .

Finally, practical considerations favor clear error review. We have previously pointed out that clear error review is "particularly" important where patent law is at issue because patent law is "a field where so much depends upon familiarity with specific scientific problems and principles not usually contained in the general storehouse of knowledge and experience." A district court judge who has presided over, and listened to, the entirety of a proceeding has a comparatively greater opportunity to gain that familiarity than an

## CLAIM CONSTRUCTION

appeals court judge who must read a written transcript or perhaps just those portions to which the parties have referred.

### B

Sandoz argues that claim construction mostly consists of construing a set of written documents that do not give rise to subsidiary factual disputes. It adds that separating “factual” from “legal” questions is often difficult. And Sandoz, like the Federal Circuit itself, argues that it is simpler for that appellate court to review the entirety of the district court’s claim construction *de novo* rather than to apply two separate standards.

But even were we free to ignore the Federal Rule (which we are not), we would not find this argument convincing. Courts of appeals have long found it possible to separate factual from legal matters. At the same time, the Federal Circuit’s efforts to treat factual findings and legal conclusions similarly have brought with them their own complexities. . . .

Finally, the Circuit feared that “clear error” review would bring about less uniformity. Neither the Circuit nor Sandoz, however, has shown that (or explained why) divergent claim construction stemming from divergent findings of fact (on subsidiary matters) should occur more than occasionally. After all, the Federal Circuit will continue to review *de novo* the district court’s ultimate interpretation of the patent claims. And the attorneys will no doubt bring cases construing the same claim to the attention of the trial judge; those prior cases will sometimes be binding because of issue preclusion, and sometimes will serve as persuasive authority. Moreover, it is always possible to consolidate for discovery different cases that involve construction of the same claims. And, as we said in *Markman*, subsidiary factfinding is unlikely to loom large in the universe of litigated claim construction.

### C

The dissent argues that claim construction does not involve any “factfinding,” or, if it does, claim construction factfinding is akin to the factfinding that underlies our interpretation of statutes. Its first, broader contention runs contrary to our recognition in *Markman* that claim construction has “evidentiary underpinnings” and that courts construing patent claims must sometimes make “credibility judgments” about witnesses. Indeed, . . . this case provides a perfect example of the factfinding that sometimes underlies claim construction: The parties here presented the District Court with competing fact-related claims by different experts, and the District Court resolved the issues of fact that divided those experts.

. . .

## CHAPTER 8

Neither do we find factfinding in this context sufficiently similar to the factfinding that underlies statutory interpretation. Statutes, in general, address themselves to the general public; patent claims concern a small portion of that public. Statutes typically (though not always) rest upon congressional consideration of general facts related to a reasonably broad set of social circumstances; patents typically (though not always) rest upon consideration by a few private parties, experts, and administrators of more narrowly circumscribed facts related to specific technical matters. The public, and often an adversarial public, typically considers and discusses the relevant general facts before Congress enacts a statute; only private parties, experts, and administrators likely consider the relevant technical facts before the award of a patent. Given these differences, it is not surprising that this Court has never previously compared patent claim construction in any here relevant way to statutory construction. . . . [H]owever, the Court has repeatedly compared patent claim construction to the construction of other written instruments such as deeds and contracts.

### D

Now that we have set forth *why* the Federal Circuit must apply clear error review when reviewing subsidiary factfinding in patent claim construction, it is necessary to explain *how* the rule must be applied in that context. We recognize that a district court's construction of a patent claim, like a district court's interpretation of a written instrument, often requires the judge only to examine and to construe the document's words without requiring the judge to resolve any underlying factual disputes. As all parties agree, when the district court reviews only evidence intrinsic to the patent (the patent claims and specifications, along with the patent's prosecution history), the judge's determination will amount solely to a determination of law, and the Court of Appeals will review that construction *de novo*.

In some cases, however, the district court will need to look beyond the patent's intrinsic evidence and to consult extrinsic evidence in order to understand, for example, the background science or the meaning of a term in the relevant art during the relevant time period. In cases where those subsidiary facts are in dispute, courts will need to make subsidiary factual findings about that extrinsic evidence. These are the "evidentiary underpinnings" of claim construction that we discussed in *Markman*, and this subsidiary factfinding must be reviewed for clear error on appeal.

For example, if a district court resolves a dispute between experts and makes a factual finding that, in general, a certain term of art had a particular meaning to a person of ordinary skill in the art at the time of the invention, the district court must then conduct a legal analysis: whether a skilled artisan would ascribe that same meaning to that term *in the context of the specific patent claim under review*. That is because "experts may be examined

## CLAIM CONSTRUCTION

to explain terms of art, and the state of the art, at any given time,” but they cannot be used to prove “the proper or legal construction of any instrument of writing.”

. . . The district judge, after deciding the factual dispute, will then interpret the patent claim in light of the facts as he has found them. This ultimate interpretation is a legal conclusion. The appellate court can still review the district court’s ultimate construction of the claim *de novo*. But, to overturn the judge’s resolution of an underlying factual dispute, the Court of Appeals must find that the judge, in respect to those factual findings, has made a clear error.

In some instances, a factual finding will play only a small role in a judge’s ultimate legal conclusion about the meaning of the patent term. But in some instances, a factual finding may be close to dispositive of the ultimate legal question of the proper meaning of the term in the context of the patent. Nonetheless, the ultimate question of construction will remain a legal question. Simply because a factual finding may be nearly dispositive does not render the subsidiary question a legal one. . . . It is analogous to a judge (sitting without a jury) deciding whether a defendant gave a confession voluntarily. The answer to the legal question about the voluntariness of the confession may turn upon the answer to a subsidiary factual question, say, “whether in fact the police engaged in the intimidation tactics alleged by the defendant.” An appellate court will review the trial judge’s factual determination about the alleged intimidation deferentially (though, after reviewing the factual findings, it will review a judge’s ultimate determination of voluntariness *de novo*). An appellate court similarly should review for clear error those factual findings that underlie a district court’s claim construction.

### III

We can illustrate our holding by considering an instance in which Teva, with the support of the Solicitor General, argues that the Federal Circuit wrongly reviewed the District Court’s factual finding *de novo*. . . . Teva’s patent claim specifies an active ingredient with a “molecular weight of about 5 to 9 kilodaltons.” . . . Sandoz’s basic argument [is] that the term “molecular weight” is indefinite or ambiguous. The term might refer to the weight of the most numerous molecule, it might refer to weight as calculated by the average weight of all molecules, or it might refer to weight as calculated by an average in which heavier molecules count for more. The claim, Sandoz argues, does not tell us which way we should calculate weight.

To illustrate, imagine we have a sample of copolymer-1 (the active ingredient) made up of 10 molecules: 4 weigh 6 kilodaltons each, 3 weigh 8 kilodaltons each, and 3 weigh 9 kilodaltons each. Using the first method of calculation, the “molecular weight” would be 6 kilodaltons, the weight of the most prevalent molecule. Using the second method, the molecular weight would be 7.5 (total weight, 75, divided by the number of molecules, 10).

Using the third method, the molecular weight would be more than 8, depending upon how much extra weight we gave to the heavier molecules.

Teva argued in the District Court that the term “molecular weight” in the patent meant molecular weight calculated in the first way (the weight of the most prevalent molecule, or peak average molecular weight). Sandoz, however, argued that figure 1 of the patent showed that . . . the patent claim term “molecular weight” did not mean molecular weight calculated by the first method. It must mean something else. It is indefinite.

The District Court did not accept Sandoz’s argument. Teva’s expert testified that a skilled artisan would understand that converting data from a chromatogram to molecular weight distribution curves like those in figure 1 would cause the peak on each curve to shift slightly; this could explain the difference between the value indicated by the peak of the curve (about 6.8) and the value in the figure’s legend (7.7). Sandoz’s expert testified that no such shift would occur. The District Court credited Teva’s expert’s account, thereby rejecting Sandoz’s expert’s explanation. The District Court’s finding about this matter was a factual finding—about how a skilled artisan would understand the way in which a curve created from chromatogram data reflects molecular weights. Based on that factual finding, the District Court reached the legal conclusion that figure 1 did not undermine Teva’s argument that molecular weight referred to the first method of calculation . . . .

When the Federal Circuit reviewed the District Court’s decision, it recognized that the peak of the curve did not match the 7.7 kilodaltons listed in the legend of figure 1. But the Federal Circuit did not accept Teva’s expert’s explanation as to how a skilled artisan would expect the peaks of the curves to shift. And it failed to accept that explanation without finding that the District Court’s contrary determination was “clearly erroneous.” The Federal Circuit should have accepted the District Court’s finding unless it was “clearly erroneous.” Our holding today makes clear that, in failing to do so, the Federal Circuit was wrong.

. . .

We vacate the Federal Circuit’s judgment, and we remand the case for further proceedings consistent with this opinion.



When the USPTO examines utility patent claims before issuance, it reads them according to a standard that it calls the “broadest reasonable interpretation.” The AIA established several administrative proceedings for reviewing the validity of issued

## CLAIM CONSTRUCTION

patents, the two most important of which are inter partes review and post-grant review. *See* 35 U.S.C. §§ 311-319 (establishing inter partes review proceeding); 35 U.S.C. §§ 321-329 (establishing post grant review proceeding). When the USPTO began administering those proceedings, it applied the same “broadest reasonable interpretation” standard. The case below evaluated whether the agency had the authority to do so.

### *Cuozzo Speed Technologies, LLC v. Lee* 136 S. Ct. 2131 (2016)

Justice BREYER delivered the opinion of the Court.

The Leahy–Smith America Invents Act creates a process called “inter partes review.” That review process allows a third party to ask the U.S. Patent and Trademark Office to reexamine the claims in an already-issued patent and to cancel any claim that the agency finds to be unpatentable in light of prior art.

...

[One AIA] provision grants the Patent Office the authority to issue “regulations . . . establishing and governing inter partes review under this chapter.”

Does this provision authorize the Patent Office to issue a regulation stating that the agency, in inter partes review, “shall construe a patent claim according to its broadest reasonable construction in light of the specification of the patent in which it appears”? 37 CFR § 42.100(b) (2015).

... We ... conclude that the ... provision authorizes the Patent Office to issue the regulation before us.

I

A

An inventor obtains a patent by applying to the Patent Office. A patent examiner with expertise in the relevant field reviews an applicant’s patent claims, considers the prior art, and determines whether each claim meets the applicable patent law requirements. Then, the examiner accepts a claim, or rejects it and explains why.

If the examiner rejects a claim, the applicant can resubmit a narrowed (or otherwise modified) claim, which the examiner will consider anew, measuring the new claim against the same patent law requirements. If the examiner rejects the new claim, the inventor typically has yet another chance to respond with yet another amended claim. Ultimately, the Patent Office makes a final decision allowing or rejecting the application. The applicant may seek judicial review of any final rejection.

## CHAPTER 8

For several decades, the Patent Office has also possessed the authority to reexamine—and perhaps cancel—a patent claim that it had previously allowed. . . .

In 2011, Congress enacted the statute before us. That statute modifies “inter partes reexamination,” which it now calls “inter partes review.” Like inter partes reexamination, any third party can ask the agency to initiate inter partes review of a patent claim. But the new statute has changed the standard that governs the Patent Office’s institution of the agency’s process. Instead of requiring that a request for reexamination raise a “substantial new question of patentability,” it now requires that a petition show “a reasonable likelihood that” the challenger “would prevail.”

The new statute provides a challenger with broader participation rights. It creates within the Patent Office a Patent Trial and Appeal Board (Board) composed of administrative patent judges, who are patent lawyers and former patent examiners, among others. That Board conducts the proceedings, reaches a conclusion, and sets forth its reasons.

The statute sets forth time limits for completing this review. It grants the Patent Office the authority to issue rules. Like its predecessors, the statute authorizes judicial review of a “final written decision” canceling a patent claim. And, the statute says that the agency’s initial decision “whether to institute an inter partes review” is “final and nonappealable.”

### III

Cuozzo . . . argues that the Patent Office lacked the legal authority to issue its regulation requiring the agency, when conducting an inter partes review, to give a patent claim “its broadest reasonable construction in light of the specification of the patent in which it appears.” 37 CFR § 42.100(b). Instead, Cuozzo contends that the Patent Office should, like the courts, give claims their “ordinary meaning . . . as understood by a person of skill in the art.” *Phillips*, 415 F.3d, at 1314.

The statute, however, contains a provision that grants the Patent Office authority to issue “regulations . . . establishing and governing inter partes review under this chapter.” 35 U.S.C. § 316(a)(4). The Court of Appeals held that this statute gives the Patent Office the legal authority to issue its broadest reasonable construction regulation. We agree.

### A

We interpret Congress’ grant of rulemaking authority in light of our decision in *Chevron, U.S.A. Inc.*, 467 U.S. 837. Where a statute is clear, the agency must follow the statute. But where a statute leaves a “gap” or is “ambiguous,” we typically interpret it as granting the agency leeway to enact rules that are reasonable in light of the text, nature, and purpose of the statute. The statute contains such a gap: No statutory provision unambiguously directs the agency to use one standard or the other. And the statute



## CLAIM CONSTRUCTION

“expressly . . . authorizes the Patent Office to engage in the process of rulemaking” to address that gap. Indeed, the statute allows the Patent Office to issue rules “governing inter partes review,” § 316(a)(4), and the broadest reasonable construction regulation is a rule that governs inter partes review.

Both the dissenting judges in the Court of Appeals and Cuozzo believe that other ordinary tools of statutory interpretation lead to a different conclusion. The dissenters, for example, point to cases in which the Circuit interpreted a grant of rulemaking authority in a different statute, § 2(b)(2)(A), as limited to *procedural* rules. These cases, however, as we just said, interpret a different statute. That statute does not clearly contain the Circuit’s claimed limitation, nor is its language the same as that of § 316(a)(4). Section 2(b)(2)(A) grants the Patent Office authority to issue “regulations” “which . . . shall govern . . . proceedings in the Office,” but the statute before us, § 316(a)(4), does not refer to “proceedings”—it refers more broadly to regulations “establishing and governing inter partes review.” The Circuit’s prior interpretation of § 2(b)(2)(A) cannot magically render unambiguous the different language in the different statute before us.

Cuozzo and its supporting *amici* believe we will reach a different conclusion if we carefully examine the purpose of inter partes review. That purpose, in their view, is to modify the previous reexamination procedures and to replace them with a “trial, adjudicatory in nature.” They point out that, under the statute, an opposing party can trigger inter partes review. Parties can engage in “discovery of relevant evidence,” including “depositions, . . . affidavits or declarations” as well as anything “otherwise necessary in the interest of justice.” § 316(a)(5). Parties may present “factual evidence and expert opinions” to support their arguments. § 316(a)(8). The challenger bears the burden of proving unpatentability. § 318(e). And, after oral argument before a panel of three of the Board’s administrative patent judges, it issues a final written decision. §§ 6, 316(a)(10), 318. Perhaps most importantly, a decision to cancel a patent normally has the same effect as a district court’s determination of a patent’s invalidity.

In light of these adjudicatory characteristics, which make these agency proceedings similar to court proceedings, Congress, in Cuozzo’s view, must have designed inter partes review as a “surrogate for court proceedings.” Cuozzo points to various sources of legislative history in support of its argument. And, if Congress intended to create a “surrogate” for court proceedings, why would Congress not also have intended the agency to use the claim construction standard that district courts apply (namely, the ordinary meaning standard), rather than the claim construction standard that patent examiners apply (namely, the broadest reasonable construction standard)?

The problem with Cuozzo’s argument, however, is that, in other significant respects, inter partes review is less like a judicial proceeding and more like a specialized agency proceeding. Parties that initiate the proceeding need not have a concrete stake in the

outcome; indeed, they may lack constitutional standing. As explained above, challengers need not remain in the proceeding; rather, the Patent Office may continue to conduct an inter partes review even after the adverse party has settled. § 317(a). Moreover, as is the case here, the Patent Office may intervene in a later *judicial* proceeding to defend its decision—even if the private challengers drop out. And the burden of proof in inter partes review is different than in the district courts: In inter partes review, the challenger (or the Patent Office) must establish unpatentability “by a preponderance of the evidence”; in district court, a challenger must prove invalidity by “clear and convincing evidence.”

Most importantly, these features, as well as inter partes review’s predecessors, indicate that the purpose of the proceeding is not quite the same as the purpose of district court litigation. The proceeding involves what used to be called a *reexamination* (and, as noted above, a cousin of inter partes review, *ex parte* reexamination, 35 U.S.C. § 302 *et seq.*, still bears that name). The name and accompanying procedures suggest that the proceeding offers a second look at an earlier administrative grant of a patent. Although Congress changed the name from “reexamination” to “review,” nothing convinces us that, in doing so, Congress wanted to change its basic purposes, namely, to reexamine an earlier agency decision. Thus, in addition to helping resolve concrete patent-related disputes among parties, inter partes review helps protect the public’s “paramount interest in seeing that patent monopolies . . . are kept within their legitimate scope.”

Finally, neither the statutory language, its purpose, or its history suggest that Congress considered what standard the agency should apply when reviewing a patent claim in inter partes review. *Cuozzo* contends that § 301(d), explaining that the Patent Office should “determine the proper meaning of a patent claim,” reinforces its conclusion that the ordinary meaning standard should apply. But viewed against a background of language and practices indicating that Congress designed a hybrid proceeding, § 301(d)’s reference to the “proper meaning” of a claim is ambiguous. It leaves open the question of which claim construction standard is “proper.”

The upshot is, whether we look at statutory language alone, or that language in context of the statute’s purpose, we find an express delegation of rulemaking authority, a “gap” that rules might fill, and “ambiguity” in respect to the boundaries of that gap. We consequently turn to the question whether the Patent Office’s regulation is a reasonable exercise of its rulemaking authority.

## B

We conclude that the regulation represents a reasonable exercise of the rulemaking authority that Congress delegated to the Patent Office. For one thing, construing a patent claim according to its broadest reasonable construction helps to protect the public. A reasonable, yet unlawfully broad claim might discourage the use of the invention by a

## CLAIM CONSTRUCTION

member of the public. Because an examiner's (or reexaminer's) use of the broadest reasonable construction standard increases the possibility that the examiner will find the claim too broad (and deny it), use of that standard encourages the applicant to draft narrowly. This helps ensure precision while avoiding overly broad claims, and thereby helps prevent a patent from tying up too much knowledge, while helping members of the public draw useful information from the disclosed invention and better understand the lawful limits of the claim.

For another, past practice supports the Patent Office's regulation. The Patent Office has used this standard for more than 100 years. It has applied that standard in proceedings, which, as here, resemble district court litigation. It also applies that standard in proceedings that may be consolidated with a concurrent inter partes review.

Cuozzo makes two arguments in response. First, Cuozzo says that there is a critical difference between the Patent Office's initial *examination* of an application to determine if a patent should issue, and this proceeding, in which the agency *reviews* an already-issued patent. In an initial examination of an application for a patent the examiner gives the claim its broadest reasonable construction. But if the patent examiner rejects the claim, then . . . the applicant has a right to amend and resubmit the claim. And the examiner and applicant may repeat this process at least once more. This system—broad construction with a chance to amend—both protects the public from overly broad claims and gives the applicant a fair chance to draft a precise claim that will qualify for patent protection. In inter partes review, however, the broadest reasonable construction standard may help protect certain public interests, but there is no absolute right to amend any challenged patent claims. This, Cuozzo says, is unfair to the patent holder.

The process however, is not as unfair as Cuozzo suggests. The patent holder may, at least once in the process, make a motion to do just what he would do in the examination process, namely, amend or narrow the claim. § 316(d). This opportunity to amend, together with the fact that the original application process may have presented several additional opportunities to amend the patent, means that use of the broadest reasonable construction standard is, as a general matter, not unfair to the patent holder in any obvious way.

Cuozzo adds that, as of June 30, 2015, only 5 out of 86 motions to amend have been granted. But these numbers may reflect the fact that no amendment could save the inventions at issue, *i.e.*, that the patent should have never issued at all.

To the extent Cuozzo's statistical argument takes aim at the manner in which the Patent Office has exercised its authority, that question is not before us. Indeed, in this particular case, the agency determined that Cuozzo's proposed amendment "enlarged,"

rather than narrowed, the challenged claims. *Cuozzo* does not contend that the decision not to allow its amendment is “arbitrary” or “capricious,” or “otherwise unlawful.”

Second, *Cuozzo* says that the use of the broadest reasonable construction standard in *inter partes* review, together with use of an ordinary meaning standard in district court, may produce inconsistent results and cause added confusion. A district court may find a patent claim to be valid, and the agency may later cancel that claim in its own review. We recognize that that is so. This possibility, however, has long been present in our patent system, which provides different tracks—one in the Patent Office and one in the courts—for the review and adjudication of patent claims. As we have explained above, *inter partes* review imposes a different burden of proof on the challenger. These different evidentiary burdens mean that the possibility of inconsistent results is inherent to Congress’ regulatory design.

Moreover, the Patent Office uses the broadest reasonable construction standard in other proceedings, . . . which may implicate patents that are later reviewed in district court. The statute gives the Patent Office the power to consolidate these other proceedings with *inter partes* review. To try to create uniformity of standards would consequently prove difficult. And we cannot find unreasonable the Patent Office’s decision to prefer a degree of inconsistency in the standards used between the courts and the agency, rather than among agency proceedings.

Finally, *Cuozzo* and its supporting *amici* offer various policy arguments in favor of the ordinary meaning standard. The Patent Office is legally free to accept or reject such policy arguments on the basis of its own reasoned analysis. Having concluded that the Patent Office’s regulation, selecting the broadest reasonable construction standard, is reasonable in light of the rationales described above, we do not decide whether there is a better alternative as a policy matter. That is a question that Congress left to the particular expertise of the Patent Office.

### Context and Application

1. In 2018, the USPTO changed course. In an *inter partes* review, the agency now uses “the same claim construction standard that would be used to construe the claim in a civil action . . . , including construing the claim in accordance with the ordinary and customary meaning of such claim as understood by one of ordinary skill in the art and the prosecution history pertaining to the patent.” 37 C.F.R. § 42.100. The same standard is also applied in post-grant review. 37 C.F.R. § 42.200. Having read *Cuozzo*, which standard do you think is better suited to the nature of the proceedings? Should the USPTO continue to apply the broadest reasonable construction approach during patent prosecution, or should it apply the “ordinary and customary meaning” standard there too?

## 9. INFRINGEMENT

Under 35 U.S.C. § 271(a), a patent is infringed when someone “makes, uses, offers to sell, or sells any patented invention, within the United States or imports into the United States any patented invention during the term of the patent therefor” without permission. Thus, to analyze infringement, a court must compare the accused product or process to the patent. If the claims of the patent, properly construed, encompass the product or process, then taking one of the aforementioned actions without permissions is a direct, literal infringement of the patent. To put it another way, direct infringement occurs when the alleged infringing product or process meets all elements of a utility patent claim. However, through common law development and statutory amendment, infringement liability can still attach even in some circumstances where these conditions are not met. For example, liability can be found under the doctrine of equivalents or for indirect infringement. There may also be liability when some components of a patented good, some step in a patented process, or some portion of an offer and delivery is made or performed abroad. As you read the following sections, think about how the courts try to balance fairness concerns for patent holders with certainty concerns for others in the field or consumers. What characteristics do courts use to distinguish between situations where infringement liability should be expanded beyond direct, literal infringement and those where it should not?

### A. Direct, Literal Infringement

Direct, literal infringement is when a person has engaged in one of the activities described in 35 U.S.C. § 271(a):

Except as otherwise provided in this title, whoever without authority makes, uses, offers to sell, or sells any patented invention, within the United States or imports into the United States any patented invention during the term of the patent therefor, infringes the patent.

35 U.S.C. § 271(a). The *direct* part of the infringement is that the defendant itself has engaged in the activity. The *literal* part is that the accused device or process “reads on” the patent—that is, it meets every limitation as construed during claim construction.

*Larami Corp. v. Amron*  
27 U.S.P.Q. 2d 1280 (E.D. Pa. 1993)

REED, J.

This is a patent case concerning toy water guns manufactured by plaintiff Larami Corporation (“Larami”). Currently before me is Larami’s motion for partial summary judgment of noninfringement of United States Patent No. 4,239,129 (“the ‘129 patent”).

I

Larami manufactures a line of toy water guns called “SUPER SOAKERS.” This line includes five models. All use a hand-operated air pump to pressurize water and a “pinch trigger” valve mechanism for controlling the ejection of the pressurized water. All feature detachable water reservoirs prominently situated outside and above the barrel of the gun.

...

Defendants Alan Amron and Talk To Me Products, Inc. (hereinafter referred to collectively as “TTMP”) claim that the SUPER SOAKER guns infringe on the ‘129 patent . . . . The ‘129 patent covers a water gun which, like the SUPER SOAKERS, operates by pressurizing water housed in a tank with an air pump. In the ‘129 patent, the pressure enables the water to travel out of the tank through a trigger-operated valve into an outlet tube and to squirt through a nozzle. Unlike the SUPER SOAKERS, the ‘129 patent also contains various electrical features to illuminate the water stream and create noises. Also, the water tank in the ‘129 patent is not detachable, but is contained within a housing in the body of the water gun.

The “Background of the Invention” contained in the ‘129 patent reads as follows:

Children of all ages, especially boys, through the years have exhibited a fascination for water, lights and noise and the subject invention deals with these factors embodied in a toy simulating a pistol.

An appreciable number of U.S. patents have been issued which are directed to water pistols but none appear to disclose a unique assemble of components which can be utilized to simultaneously produce a jet or stream of water, means for illuminating the stream and a noise, or if so desired, one which can be operated without employing the noise and stream illuminating means. A reciprocal pump is employed to obtain sufficient pressure whereby the pistol can eject a stream an appreciable distance in the neighborhood of thirty feet and this stream can be illuminated to more or less simulate a lazer beam.

Larami brought this action seeking a declaration that the “SUPER SOAKER” does not infringe the ‘129 patent, TTMP counterclaimed for infringement of the ‘129 patent.

## INFRINGEMENT

### II

#### B

A patent owner's right to exclude others from making, using or selling the patented invention is defined and limited by the language in that patent's claims. Thus, establishing infringement requires the interpretation of the "elements" or "limitations" of the claim and a comparison of the accused product with those elements as so interpreted. . . .

...

A patent holder can seek to establish patent infringement in either of two ways: by demonstrating that every element of a claim (1) is literally infringed or (2) is infringed under the doctrine of equivalents. To put it a different way, because every element of a claim is essential and material to that claim, a patent owner must, to meet the burden of establishing infringement, "show the presence of every element or its substantial equivalent in the accused device." If even *one* element of a patent's claim is missing from the accused product, then "there can be no infringement as a matter of law."

#### 1

TTMP claims that SUPER SOAKER 20 literally infringes claim 1 of the '129 patent. Claim 1 describes the water gun as:

a toy comprising an elongated housing case having a chamber therein for a liquid (tank), a pump including a piston having an exposed rod (piston rod) and extending rearwardly of said toy facilitating manual operation for building up an appreciable amount of pressure in said chamber for ejecting a stream of liquid therefrom an appreciable distance substantially forwardly of said toy, and means for controlling the ejection.

U.S. Patent No. 4,239,129 (bracketed words supplied; see Diagram A, the '129 patent, attached hereto).

Claim 1 requires, among other things, that the toy gun have "an elongated housing having a chamber therein for a liquid." The SUPER SOAKER 20 water gun, in contrast, has an external water reservoir (chamber) that is detachable from the gun housing, and not contained within the housing. TTMP argues that SUPER SOAKER 20 contains a "chamber therein for a liquid" *as well as* a detachable water reservoir. It is difficult to discern from TTMP's memorandum of law exactly where it contends the "chamber therein" is located in SUPER SOAKER 20. Furthermore, after having examined SUPER SOAKER 20, I find that it is plain that there is no "chamber" for liquid contained within the housing of the water gun. The only element of SUPER SOAKER 20 which could be described as a "chamber" for liquid is the external water reservoir located atop the housing. Indeed, liquid is located within the housing only when the trigger causes the

liquid to pass from the external water reservoir through the tubing in the housing and out of the nozzle at the front end of the barrel. SUPER SOAKER 20 itself shows that such a transitory avenue for the release of liquid is clearly not a “chamber therein for liquid.” Therefore, because the absence of even one element of a patent's claim from the accused product means there can be no finding of literal infringement, I find that SUPER SOAKER 20 does not infringe claim 1 of the '129 patent as a matter of law.

...

Accordingly, I conclude that the SUPER SOAKER 20 water gun does not literally infringe claim 1 of the '129 patent. . . .

### Context & Application

1. Think back to the cases you read on claim construction. Claim construction rulings often are determinative to infringement determinations, as terms are construed in ways that either include or exclude elements of accused products. At the same time, an overly broad construction may result in an invalidity ruling. Was there any construction of “therein” that would have reached the external chamber in the accused product?

2. The Larami case shows how the “all elements” rule is applied in the utility patent infringement analysis. It also involves a childhood toy beloved by many—the Super Soaker. The Super Soaker was invented by rocket scientist Lonnie Johnson, who worked on the Galileo and Cassini satellite programs and in development of the B2 stealth bomber. His biography and the story behind the invention are both interesting. On his background:

Born nearly 70 years ago in the segregated South, the African American inventor has had to prove himself as a talented and capable scientist. His parents picked cotton on his grandfather's farm and Johnson attended an all-black high school. He graduated from Tuskegee University before joining the U.S. Air Force as an engineer, then later working for NASA.

David Kindy, *The Accidental Invention of the Super Soaker*, SMITHSONIAN MAGAZINE (June 21, 2019), <https://www.smithsonianmag.com/innovation/accidental-invention-super-soaker-180972428/>. And how Johnson came up with the invention, while working for NASA:

Johnson was at home in 1982 working on an idea for an improved heat pump—a device for heating and cooling that mechanically transfers heat to another source—when his creation sprang a leak. A burst of water shot across the room and Johnson immediately thought, “That would make a great squirt gun.”



*Id.* How many inventions do you think come about this way? If inventions often come about when their inventors are trying to solve different problems, how does or should that impact the way we think about patent doctrines?

## B. The Doctrine of Equivalents

Courts and scholars often emphasize the importance of precise claim construction, recognizing that patent holders need to know what they have and third parties need to know what they are forbidden from doing—at least, without a license. But bright-line rules can have seemingly harsh consequences:

Strict interpretations of patent infringement boundaries sometimes operate in ways that appear unfair to patent holders. Early cases that extended infringement boundaries did so when a third party was deliberately circumventing a patent while producing goods that embodied the heart of the invention. In addition to circumvention, early indirect infringement cases addressed the difficulties some patent holders had enforcing their patents against end users when manufacturers and distributors were the least cost avoiders (and easiest to sue).

Sarah R. Wasserman Rajec, *Infringement, Unbound*, 32 HARV. J.L. & TECH. 117 (2018). Accordingly, we've seen a number of doctrines expand infringement liability to beyond literal, direct infringement in the United States.

One of these is the doctrine of equivalents (sometimes referred to as the "DOE"). The DOE is a judge-made doctrine that occurs when the elements of a claim are not all met literally by an accused device, yet the device is deemed infringing. For example, if a patent claim included elements A, B, C, and D, and the accused product included A, B, C, and X, the patent holder might yet be able to argue infringement if X performs the same function, in the same way, to achieve the same result as D, or if X is insubstantially different from D.

The DOE can be traced back to *Winans v. Denmead*, 56 U.S. 330 (1853) (covered in Chapter 2 of this book). The claim in that case covered "the body of a car for the transportation of coal, &c., in the form of a frustum of a cone." The accused device, rather than having a circular cross section, like the frustum of a cone, was an octagon. The Court rejected the argument that it had to be precisely a circle in order to infringe. Instead, the DOE was born.

There was some question whether the doctrine of equivalents, as a judge-made doctrine, survived passage of the 1952 Act, and if so, what role prosecution history estoppel would play in limiting the claim to equivalents. The Court took this question up in *Warner-Jenkinson*, which provides a summary of the doctrinal history of the DOE.

*Warner–Jenkinson Company, Inc. v. Hilton Davis Chemical Co.*  
520 U.S. 17 (1997)

Justice THOMAS delivered the opinion of the Court.

Nearly 50 years ago, this Court in *Graver Tank & Mfg. Co. v. Linde Air Products Co.*, 339 U.S. 605 (1950), set out the modern contours of what is known in patent law as the “doctrine of equivalents.” Under this doctrine, a product or process that does not literally infringe upon the express terms of a patent claim may nonetheless be found to infringe if there is “equivalence” between the elements of the accused product or process and the claimed elements of the patented invention. Petitioner, which was found to have infringed upon respondent’s patent under the doctrine of equivalents, invites us to speak the death of that doctrine. We decline that invitation. The significant disagreement within the Court of Appeals for the Federal Circuit concerning the application of *Graver Tank* suggests, however, that the doctrine is not free from confusion. We therefore will endeavor to clarify the proper scope of the doctrine.

I

The essential facts of this case are few. Petitioner Warner–Jenkinson Co. and respondent Hilton Davis Chemical Co. manufacture dyes. Impurities in those dyes must be removed. Hilton Davis holds United States Patent No. 4,560,746 (’746 patent), which discloses an improved purification process involving “ultrafiltration.” The ’746 process filters impure dye through a porous membrane at certain pressures and pH levels, resulting in a high purity dye product.

The ’746 patent issued in 1985. As relevant to this case, the patent claims as its invention an improvement in the ultrafiltration process as follows:

In a process for the purification of a dye the improvement which comprises: subjecting an aqueous solution to ultrafiltration through a membrane having a nominal pore diameter of 5–15 Angstroms under a hydrostatic pressure of approximately 200 to 400 p.s.i.g., at a pH from approximately 6.0 to 9.0, to thereby cause separation of said impurities from said dye.

The inventors added the phrase “at a pH from approximately 6.0 to 9.0” during patent prosecution. At a minimum, this phrase was added to distinguish a previous patent (the “Booth” patent) that disclosed an ultrafiltration process operating at a pH above 9.0. The parties disagree as to why the low-end pH limit of 6.0 was included as part of the claim.

In 1986, Warner–Jenkinson developed an ultrafiltration process that operated . . . at a pH of 5.0.

## INFRINGEMENT

### II

In *Graver Tank* we considered the application of the doctrine of equivalents to an accused chemical composition for use in welding that differed from the patented welding material by the substitution of one chemical element. The substituted element did not fall within the literal terms of the patent claim, but the Court nonetheless found that the “question which thus emerges is whether the substitution of one element for the other is a change of such substance as to make the doctrine of equivalents inapplicable; or conversely, whether under the circumstances the change was so insubstantial that the trial court’s invocation of the doctrine of equivalents was justified.” The Court also described some of the considerations that go into applying the doctrine of equivalents:

What constitutes equivalency must be determined against the context of the patent, the prior art, and the particular circumstances of the case. Equivalence, in the patent law, is not the prisoner of a formula and is not an absolute to be considered in a vacuum. It does not require complete identity for every purpose and in every respect. In determining equivalents, things equal to the same thing may not be equal to each other and, by the same token, things for most purposes different may sometimes be equivalents. Consideration must be given to the purpose for which an ingredient is used in a patent, the qualities it has when combined with the other ingredients, and the function which it is intended to perform. An important factor is whether persons reasonably skilled in the art would have known of the interchangeability of an ingredient not contained in the patent with one that was.

Considering those factors, the Court viewed the difference between the chemical element claimed in the patent and the substitute element to be “colorable only,” and concluded that the trial court’s judgment of infringement under the doctrine of equivalents was proper.

### A

Petitioner’s primary argument in this Court is that the doctrine of equivalents, as set out in *Graver Tank* in 1950, did not survive the 1952 revision of the Patent Act because it is inconsistent with several aspects of that Act. In particular, petitioner argues: (1) The doctrine of equivalents is inconsistent with the statutory requirement that a patentee specifically “claim” the invention covered by a patent, § 112; (2) the doctrine circumvents the patent reissue process—designed to correct mistakes in drafting or the like—and avoids the express limitations on that process, §§ 251–252; (3) the doctrine is inconsistent with the primacy of the Patent and Trademark Office (PTO) in setting the scope of a patent through the patent prosecution process; and (4) the doctrine was implicitly rejected as a general matter by Congress’ specific and limited inclusion of the doctrine in one section

regarding “means” claiming, § 112, ¶ 6. All but one of these arguments were made in *Graver Tank* in the context of the 1870 Patent Act, and failed to command a majority.

The 1952 Patent Act is not materially different from the 1870 Act with regard to claiming, reissue, and the role of the PTO. . . . Such minor differences as exist between those provisions in the 1870 and the 1952 Acts have no bearing on the result reached in *Graver Tank*, and thus provide no basis for our overruling it. In the context of infringement, we have already held that pre-1952 precedent survived the passage of the 1952 Act. . . . We see no reason to reach a different result here.

## B

We do, however, share the concern of the dissenters below that the doctrine of equivalents, as it has come to be applied since *Graver Tank*, has taken on a life of its own, unbounded by the patent claims. There can be no denying that the doctrine of equivalents, when applied broadly, conflicts with the definitional and public-notice functions of the statutory claiming requirement. Judge Nies identified one means of avoiding this conflict:

A distinction can be drawn that is not too esoteric between substitution of an equivalent for a component *in* an invention and enlarging the metes and bounds of the invention *beyond* what is claimed.

Where a claim to an invention is expressed as a combination of elements, as here, “equivalents” in the sobriquet “Doctrine of Equivalents” refers to the equivalency of an *element* or *part* of the invention with one that is substituted in the accused product or process.

This view that the accused device or process must be more than “equivalent” *overall* reconciles the Supreme Court’s position on infringement by equivalents with its concurrent statements that “the courts have no right to enlarge a patent beyond the scope of its claims as allowed by the Patent Office.” The “scope” is not enlarged if courts do not go beyond the substitution of equivalent elements.”

[*Hilton Davis Chemical Co. v. Warner-Jenkinson Co., Inc.*,] 62 F.3d 1512, 1573–74 (dissenting opinion).

We concur with this apt reconciliation of our two lines of precedent. Each element contained in a patent claim is deemed material to defining the scope of the patented invention, and thus the doctrine of equivalents must be applied to individual elements of the claim, not to the invention as a whole. It is important to ensure that the application of the doctrine, even as to an individual element, is not allowed such broad play as to effectively eliminate that element in its entirety. So long as the doctrine of equivalents does not encroach beyond the limits just described, or beyond related limits to be

## INFRINGEMENT

discussed *infra*, we are confident that the doctrine will not vitiate the central functions of the patent claims themselves.

### III

Understandably reluctant to assume this Court would overrule *Graver Tank*, petitioner has offered alternative arguments in favor of a more restricted doctrine of equivalents than it feels was applied in this case. We address each in turn.

#### A

Petitioner first argues that *Graver Tank* never purported to supersede a well-established limit on nonliteral infringement, known variously as “prosecution history estoppel” and “file wrapper estoppel.” According to petitioner, any surrender of subject matter during patent prosecution, regardless of the reason for such surrender, precludes recapturing any part of that subject matter, even if it is equivalent to the matter expressly claimed. Because, during patent prosecution, respondent limited the pH element of its claim to pH levels between 6.0 and 9.0, petitioner would have those limits form bright lines beyond which no equivalents may be claimed. Any inquiry into the reasons for a surrender, petitioner claims, would undermine the public’s right to clear notice of the scope of the patent as embodied in the patent file.

We can readily agree with petitioner that *Graver Tank* did not dispose of prosecution history estoppel as a legal limitation on the doctrine of equivalents. But petitioner reaches too far in arguing that the reason for an amendment during patent prosecution is irrelevant to any subsequent estoppel. In each of our cases cited by petitioner and by the dissent below, prosecution history estoppel was tied to amendments made to avoid the prior art, or otherwise to address a specific concern—such as obviousness—that arguably would have rendered the claimed subject matter unpatentable. Thus, in *Exhibit Supply Co. v. Ace Patents Corp.*, 315 U.S. 126 (1942) Chief Justice Stone distinguished inclusion of a limiting phrase in an original patent claim from the “very different” situation in which “the applicant, in order to meet objections in the Patent Office, based on references to the prior art, adopted the phrase as a substitute for the broader one” previously used. Similarly, in *Keystone Driller Co. v. Northwest Engineering Corp.*, 294 U.S. 42 (1935), estoppel was applied where the initial claims were “rejected on the prior art,” and where the allegedly infringing equivalent element was outside of the revised claims and within the prior art that formed the basis for the rejection of the earlier claims.

It is telling that in each case this Court probed the reasoning behind the Patent Office’s insistence upon a change in the claims. In each instance, a change was demanded because the claim as otherwise written was viewed as not describing a patentable invention at all—typically because what it described was encompassed within the prior art. But, as the United States informs us, there are a variety of other reasons why the PTO may request a

change in claim language. And if the PTO has been requesting changes in claim language without the intent to limit equivalents or, indeed, with the expectation that language it required would in many cases allow for a range of equivalents, we should be extremely reluctant to upset the basic assumptions of the PTO without substantial reason for doing so. Our prior cases have consistently applied prosecution history estoppel only where claims have been amended for a limited set of reasons, and we see no substantial cause for requiring a more rigid rule invoking an estoppel regardless of the reasons for a change.

In this case, the patent examiner objected to the patent claim due to a perceived overlap with the Booth patent, which revealed an ultrafiltration process operating at a pH above 9.0. In response to this objection, the phrase “at a pH from approximately 6.0 to 9.0” was added to the claim. While it is undisputed that the upper limit of 9.0 was added in order to distinguish the Booth patent, the reason for adding the lower limit of 6.0 is unclear. The lower limit certainly did not serve to distinguish the Booth patent, which said nothing about pH levels below 6.0. Thus, while a lower limit of 6.0, by its mere inclusion, became a material element of the claim, that did not necessarily preclude the application of the doctrine of equivalents as to that element. . . . Where the reason for the change was not related to avoiding the prior art, the change may introduce a new element, but it does not necessarily preclude infringement by equivalents of that element.

We are left with the problem, however, of what to do in a case like the one at bar, where the record seems not to reveal the reason for including the lower pH limit of 6.0. In our view, holding that certain reasons for a claim amendment may avoid the application of prosecution history estoppel is not tantamount to holding that the absence of a reason for an amendment may similarly avoid such an estoppel. Mindful that claims do indeed serve both a definitional and a notice function, we think the better rule is to place the burden on the patent holder to establish the reason for an amendment required during patent prosecution. The court then would decide whether that reason is sufficient to overcome prosecution history estoppel as a bar to application of the doctrine of equivalents to the element added by that amendment. Where no explanation is established, however, the court should presume that the patent applicant had a substantial reason related to patentability for including the limiting element added by amendment. In those circumstances, prosecution history estoppel would bar the application of the doctrine of equivalents as to that element. The presumption we have described, one subject to rebuttal if an appropriate reason for a required amendment is established, gives proper deference to the role of claims in defining an invention and providing public notice, and to the primacy of the PTO in ensuring that the claims allowed cover only subject matter that is properly patentable in a proffered patent application. Applied in this fashion, prosecution history estoppel places reasonable limits on the

## INFRINGEMENT

doctrine of equivalents, and further insulates the doctrine from any feared conflict with the Patent Act.

Because respondent has not proffered in this Court a reason for the addition of a lower pH limit, it is impossible to tell whether the reason for that addition could properly avoid an estoppel. Whether a reason in fact exists, but simply was not adequately developed, we cannot say. On remand, the Federal Circuit can consider whether reasons for that portion of the amendment were offered or not and whether further opportunity to establish such reasons would be proper.

### V

All that remains is to address the debate regarding the linguistic framework under which “equivalence” is determined. Both the parties and the Federal Circuit spend considerable time arguing whether the so-called “triple identity” test—focusing on the function served by a particular claim element, the way that element serves that function, and the result thus obtained by that element—is a suitable method for determining equivalence, or whether an “insubstantial differences” approach is better. There seems to be substantial agreement that, while the triple identity test may be suitable for analyzing mechanical devices, it often provides a poor framework for analyzing other products or processes. On the other hand, the insubstantial differences test offers little additional guidance as to what might render any given difference “insubstantial.”

In our view, the particular linguistic framework used is less important than whether the test is probative of the essential inquiry: Does the accused product or process contain elements identical or equivalent to each claimed element of the patented invention? Different linguistic frameworks may be more suitable to different cases, depending on their particular facts. A focus on individual elements and a special vigilance against allowing the concept of equivalence to eliminate completely any such elements should reduce considerably the imprecision of whatever language is used. An analysis of the role played by each element in the context of the specific patent claim will thus inform the inquiry as to whether a substitute element matches the function, way, and result of the claimed element, or whether the substitute element plays a role substantially different from the claimed element. With these limiting principles as a backdrop, we see no purpose in going further and micromanaging the Federal Circuit’s particular word choice for analyzing equivalence. We expect that the Federal Circuit will refine the formulation of the test for equivalence in the orderly course of case-by-case determinations, and we leave such refinement to that court’s sound judgment in this area of its special expertise.

### VI

Today we adhere to the doctrine of equivalents. The determination of equivalence should be applied as an objective inquiry on an element-by-element basis. Prosecution

history estoppel continues to be available as a defense to infringement, but if the patent holder demonstrates that an amendment required during prosecution had a purpose unrelated to patentability, a court must consider that purpose in order to decide whether an estoppel is precluded. Where the patent holder is unable to establish such a purpose, a court should presume that the purpose behind the required amendment is such that prosecution history estoppel would apply. Because the Court of Appeals for the Federal Circuit did not consider all of the requirements as described by us today, particularly as related to prosecution history estoppel and the preservation of some meaning for each element in a claim, we reverse its judgment and remand the case for further proceedings consistent with this opinion. It is so ordered.

*Festo Corp. v. Shoketsu Kinzoku Kogyo Kabushiki Co., Ltd.*  
535 U.S. 722 (2002)

Justice KENNEDY delivered the opinion of the Court.

This case requires us to address once again the relation between two patent law concepts, the doctrine of equivalents and the rule of prosecution history estoppel. The Court considered the same concepts in *Warner–Jenkinson Co. v. Hilton Davis Chemical Co.*, and reaffirmed that a patent protects its holder against efforts of copyists to evade liability for infringement by making only insubstantial changes to a patented invention. At the same time, we appreciated that by extending protection beyond the literal terms in a patent the doctrine of equivalents can create substantial uncertainty about where the patent monopoly ends. If the range of equivalents is unclear, competitors may be unable to determine what is a permitted alternative to a patented invention and what is an infringing equivalent.

To reduce the uncertainty, *Warner–Jenkinson* acknowledged that competitors may rely on the prosecution history, the public record of the patent proceedings. In some cases the Patent and Trademark Office (PTO) may have rejected an earlier version of the patent application on the ground that a claim does not meet a statutory requirement for patentability. When the patentee responds to the rejection by narrowing his claims, this prosecution history estops him from later arguing that the subject matter covered by the original, broader claim was nothing more than an equivalent. Competitors may rely on the estoppel to ensure that their own devices will not be found to infringe by equivalence.

In the decision now under review the Court of Appeals for the Federal Circuit held that by narrowing a claim to obtain a patent, the patentee surrenders all equivalents to the amended claim element. Petitioner asserts this holding departs from past precedent in two respects. First, it applies estoppel to every amendment made to satisfy the requirements of the Patent Act and not just to amendments made to avoid pre-emption



## INFRINGEMENT

by an earlier invention, *i.e.*, the prior art. Second, it holds that when estoppel arises, it bars suit against every equivalent to the amended claim element. The Court of Appeals acknowledged that this holding departed from its own cases, which applied a flexible bar when considering what claims of equivalence were estopped by the prosecution history. Petitioner argues that by replacing the flexible bar with a complete bar the Court of Appeals cast doubt on many existing patents that were amended during the application process when the law, as it then stood, did not apply so rigorous a standard.

We granted certiorari to consider these questions.

### I

Petitioner Festo Corporation owns two patents for an improved magnetic rodless cylinder, a piston-driven device that relies on magnets to move objects in a conveying system. The device has many industrial uses and has been employed in machinery as diverse as sewing equipment and the Thunder Mountain ride at Disney World. Although the precise details of the cylinder's operation are not essential here, the prosecution history must be considered.

Petitioner's patent applications, as often occurs, were amended during the prosecution proceedings. The application for the first patent, the Stoll Patent (U.S. Patent No. 4,354,125), was amended after the patent examiner rejected the initial application because the exact method of operation was unclear and some claims were made in an impermissible way. The inventor, Dr. Stoll, submitted a new application designed to meet the examiner's objections and also added certain references to prior art. The second patent, the Carroll Patent (U.S. Patent No. 3,779,401), was also amended during a reexamination proceeding. The prior art references were added to this amended application as well. Both amended patents added a new limitation—that the inventions contain a pair of sealing rings, each having a lip on one side, which would prevent impurities from getting on the piston assembly. The amended Stoll Patent added the further limitation that the outer shell of the device, the sleeve, be made of a magnetizable material.

After Festo began selling its rodless cylinder, respondents (whom we refer to as SMC) entered the market with a device similar, but not identical, to the ones disclosed by Festo's patents. SMC's cylinder, rather than using two one-way sealing rings, employs a single sealing ring with a two-way lip. Furthermore, SMC's sleeve is made of a nonmagnetizable alloy. SMC's device does not fall within the literal claims of either patent, but petitioner contends that it is so similar that it infringes under the doctrine of equivalents.

SMC contends that Festo is estopped from making this argument because of the prosecution history of its patents. The sealing rings and the magnetized alloy in the Festo product were both disclosed for the first time in the amended applications. In SMC's view, these amendments narrowed the earlier applications, surrendering alternatives that are

the very points of difference in the competing devices—the sealing rings and the type of alloy used to make the sleeve. As Festo narrowed its claims in these ways in order to obtain the patents, says SMC, Festo is now estopped from saying that these features are immaterial and that SMC's device is an equivalent of its own.

...

The *en banc* [Federal Circuit held] that prosecution history estoppel barred Festo from asserting that the accused device infringed its patents under the doctrine of equivalents. The court held, with only one judge dissenting, that estoppel arises from any amendment that narrows a claim to comply with the Patent Act, not only from amendments made to avoid prior art. More controversial in the Court of Appeals was its further holding: When estoppel applies, it stands as a complete bar against any claim of equivalence for the element that was amended. . . . In the court's view a complete-bar rule, under which estoppel bars all claims of equivalence to the narrowed element, would promote certainty in the determination of infringement cases.

Four judges dissented from the decision to adopt a complete bar. . . . We granted certiorari.

## II

The patent laws “promote the Progress of Science and useful Arts” by rewarding innovation with a temporary monopoly. U.S. Const., Art. I, § 8, cl. 8. The monopoly is a property right; and like any property right, its boundaries should be clear. This clarity is essential to promote progress, because it enables efficient investment in innovation. A patent holder should know what he owns, and the public should know what he does not. For this reason, the patent laws require inventors to describe their work in “full, clear, concise, and exact terms,” 35 U.S.C. § 112, as part of the delicate balance the law attempts to maintain between inventors, who rely on the promise of the law to bring the invention forth, and the public, which should be encouraged to pursue innovations, creations, and new ideas beyond the inventor's exclusive rights.

Unfortunately, the nature of language makes it impossible to capture the essence of a thing in a patent application. The inventor who chooses to patent an invention and disclose it to the public, rather than exploit it in secret, bears the risk that others will devote their efforts toward exploiting the limits of the patent's language . . . .

The language in the patent claims may not capture every nuance of the invention or describe with complete precision the range of its novelty. If patents were always interpreted by their literal terms, their value would be greatly diminished. Unimportant and insubstantial substitutes for certain elements could defeat the patent, and its value to inventors could be destroyed by simple acts of copying. For this reason, the clearest rule

## INFRINGEMENT

of patent interpretation, literalism, may conserve judicial resources but is not necessarily the most efficient rule. The scope of a patent is not limited to its literal terms but instead embraces all equivalents to the claims described. See *Winans v. Denmead*, 56 U.S. (15 How.) 330, 347 (1854).

It is true that the doctrine of equivalents renders the scope of patents less certain. It may be difficult to determine what is, or is not, an equivalent to a particular element of an invention. If competitors cannot be certain about a patent's extent, they may be deterred from engaging in legitimate manufactures outside its limits, or they may invest by mistake in competing products that the patent secures. In addition the uncertainty may lead to wasteful litigation between competitors, suits that a rule of literalism might avoid. These concerns with the doctrine of equivalents, however, are not new. Each time the Court has considered the doctrine, it has acknowledged this uncertainty as the price of ensuring the appropriate incentives for innovation, and it has affirmed the doctrine over dissents that urged a more certain rule. When the Court in *Winans v. Denmead*, first adopted what has become the doctrine of equivalents, it stated that "the exclusive right to the thing patented is not secured, if the public are at liberty to make substantial copies of it, varying its form or proportions." . . .

### III

Prosecution history estoppel requires that the claims of a patent be interpreted in light of the proceedings in the PTO during the application process. Estoppel is a "rule of patent construction" that ensures that claims are interpreted by reference to those "that have been cancelled or rejected." The doctrine of equivalents allows the patentee to claim those insubstantial alterations that were not captured in drafting the original patent claim but which could be created through trivial changes. When, however, the patentee originally claimed the subject matter alleged to infringe but then narrowed the claim in response to a rejection, he may not argue that the surrendered territory comprised unforeseen subject matter that should be deemed equivalent to the literal claims of the issued patent. On the contrary, "by the amendment the patentee recognized and emphasized the difference between the two phrases, and the difference which the patentee thus disclaimed must be regarded as material."

A rejection indicates that the patent examiner does not believe the original claim could be patented. While the patentee has the right to appeal, his decision to forgo an appeal and submit an amended claim is taken as a concession that the invention as patented does not reach as far as the original claim. Were it otherwise, the inventor might avoid the PTO's gatekeeping role and seek to recapture in an infringement action the very subject matter surrendered as a condition of receiving the patent.

## CHAPTER 9

Prosecution history estoppel ensures that the doctrine of equivalents remains tied to its underlying purpose. Where the original application once embraced the purported equivalent but the patentee narrowed his claims to obtain the patent or to protect its validity, the patentee cannot assert that he lacked the words to describe the subject matter in question. The doctrine of equivalents is premised on language's inability to capture the essence of innovation, but a prior application describing the precise element at issue undercuts that premise. In that instance the prosecution history has established that the inventor turned his attention to the subject matter in question, knew the words for both the broader and narrower claim, and affirmatively chose the latter.

### A

The first question in this case concerns the kinds of amendments that may give rise to estoppel. Petitioner argues that estoppel should arise when amendments are intended to narrow the subject matter of the patented invention, for instance, amendments to avoid prior art, but not when the amendments are made to comply with requirements concerning the form of the patent application. . . .

Petitioner is correct that estoppel has been discussed most often in the context of amendments made to avoid the prior art. It does not follow, however, that amendments for other purposes will not give rise to estoppel. Prosecution history may rebut the inference that a thing not described was indescribable. That rationale does not cease simply because the narrowing amendment, submitted to secure a patent, was for some purpose other than avoiding prior art.

We agree with the Court of Appeals that a narrowing amendment made to satisfy any requirement of the Patent Act may give rise to an estoppel. As that court explained, a number of statutory requirements must be satisfied before a patent can issue. The claimed subject matter must be useful, novel, and not obvious. In addition, the patent application must describe, enable, and set forth the best mode of carrying out the invention. § 112. These latter requirements must be satisfied before issuance of the patent, for exclusive patent rights are given in exchange for disclosing the invention to the public. What is claimed by the patent application must be the same as what is disclosed in the specification; otherwise the patent should not issue. The patent also should not issue if the other requirements of § 112 are not satisfied, and an applicant's failure to meet these requirements could lead to the issued patent being held invalid in later litigation.

Petitioner contends that amendments made to comply with § 112 concern the form of the application and not the subject matter of the invention. The PTO might require the applicant to clarify an ambiguous term, to improve the translation of a foreign word, or to rewrite a dependent claim as an independent one. In these cases, petitioner argues, the applicant has no intention of surrendering subject matter and should not be estopped

## INFRINGEMENT

from challenging equivalent devices. While this may be true in some cases, petitioner's argument conflates the patentee's reason for making the amendment with the impact the amendment has on the subject matter.

Estoppel arises when an amendment is made to secure the patent and the amendment narrows the patent's scope. If a § 112 amendment is truly cosmetic, then it would not narrow the patent's scope or raise an estoppel. On the other hand, if a § 112 amendment is necessary and narrows the patent's scope—even if only for the purpose of better description—estoppel may apply. A patentee who narrows a claim as a condition for obtaining a patent disavows his claim to the broader subject matter, whether the amendment was made to avoid the prior art or to comply with § 112. We must regard the patentee as having conceded an inability to claim the broader subject matter or at least as having abandoned his right to appeal a rejection. In either case estoppel may apply.

### B

Petitioner concedes that the limitations at issue—the sealing rings and the composition of the sleeve—were made for reasons related to § 112, if not also to avoid the prior art. Our conclusion that prosecution history estoppel arises when a claim is narrowed to comply with § 112 gives rise to the second question presented: Does the estoppel bar the inventor from asserting infringement against any equivalent to the narrowed element or might some equivalents still infringe? The Court of Appeals held that prosecution history estoppel is a complete bar, and so the narrowed element must be limited to its strict literal terms. Based upon its experience the Court of Appeals decided that the flexible-bar rule is unworkable because it leads to excessive uncertainty and burdens legitimate innovation. For the reasons that follow, we disagree with the decision to adopt the complete bar.

Though prosecution history estoppel can bar a patentee from challenging a wide range of alleged equivalents made or distributed by competitors, its reach requires an examination of the subject matter surrendered by the narrowing amendment. The complete bar avoids this inquiry by establishing a *per se* rule; but that approach is inconsistent with the purpose of applying the estoppel in the first place—to hold the inventor to the representations made during the application process and to the inferences that may reasonably be drawn from the amendment. By amending the application, the inventor is deemed to concede that the patent does not extend as far as the original claim. It does not follow, however, that the amended claim becomes so perfect in its description that no one could devise an equivalent. After amendment, as before, language remains an imperfect fit for invention. The narrowing amendment may demonstrate what the claim is not; but it may still fail to capture precisely what the claim is. There is no reason why a narrowing amendment should be deemed to relinquish equivalents unforeseeable at the time of the amendment and beyond a fair interpretation of what was surrendered. Nor is

there any call to foreclose claims of equivalence for aspects of the invention that have only a peripheral relation to the reason the amendment was submitted. The amendment does not show that the inventor suddenly had more foresight in the drafting of claims than an inventor whose application was granted without amendments having been submitted. It shows only that he was familiar with the broader text and with the difference between the two. As a result, there is no more reason for holding the patentee to the literal terms of an amended claim than there is for abolishing the doctrine of equivalents altogether and holding every patentee to the literal terms of the patent.

...

In *Warner–Jenkinson* we struck the appropriate balance by placing the burden on the patentee to show that an amendment was not for purposes of patentability . . . .

When the patentee is unable to explain the reason for amendment, estoppel not only applies but also “bars the application of the doctrine of equivalents as to that element.” These words do not mandate a complete bar; they are limited to the circumstance where “no explanation is established.” They do provide, however, that when the court is unable to determine the purpose underlying a narrowing amendment—and hence a rationale for limiting the estoppel to the surrender of particular equivalents—the court should presume that the patentee surrendered all subject matter between the broader and the narrower language.

Just as *Warner–Jenkinson* held that the patentee bears the burden of proving that an amendment was not made for a reason that would give rise to estoppel, we hold here that the patentee should bear the burden of showing that the amendment does not surrender the particular equivalent in question. . . . The patentee, as the author of the claim language, may be expected to draft claims encompassing readily known equivalents. A patentee’s decision to narrow his claims through amendment may be presumed to be a general disclaimer of the territory between the original claim and the amended claim. There are some cases, however, where the amendment cannot reasonably be viewed as surrendering a particular equivalent. The equivalent may have been unforeseeable at the time of the application; the rationale underlying the amendment may bear no more than a tangential relation to the equivalent in question; or there may be some other reason suggesting that the patentee could not reasonably be expected to have described the insubstantial substitute in question. In those cases the patentee can overcome the presumption that prosecution history estoppel bars a finding of equivalence.

This presumption is not, then, just the complete bar by another name. Rather, it reflects the fact that the interpretation of the patent must begin with its literal claims, and the prosecution history is relevant to construing those claims. When the patentee has chosen to narrow a claim, courts may presume the amended text was composed with awareness

## INFRINGEMENT

of this rule and that the territory surrendered is not an equivalent of the territory claimed. In those instances, however, the patentee still might rebut the presumption that estoppel bars a claim of equivalence. The patentee must show that at the time of the amendment one skilled in the art could not reasonably be expected to have drafted a claim that would have literally encompassed the alleged equivalent.

### IV

On the record before us, we cannot say petitioner has rebutted the presumptions that estoppel applies and that the equivalents at issue have been surrendered. Petitioner concedes that the limitations at issue—the sealing rings and the composition of the sleeve—were made in response to a rejection for reasons under § 112, if not also because of the prior art references. As the amendments were made for a reason relating to patentability, the question is not whether estoppel applies but what territory the amendments surrendered. While estoppel does not effect a complete bar, the question remains whether petitioner can demonstrate that the narrowing amendments did not surrender the particular equivalents at issue. On these questions, SMC may well prevail, for the sealing rings and the composition of the sleeve both were noted expressly in the prosecution history. These matters, however, should be determined in the first instance by further proceedings in the Court of Appeals or the District Court.

The judgment of the Federal Circuit is vacated, and the case is remanded for further proceedings consistent with this opinion.

### Context & Application

1. In *Festo*, the Supreme Court stated that “[a] patent holder should know what he owns, and the public should know what he does not.” Does the DOE appear contradictory to this statement? Do you think the defendants in *Warner Jenkinson* were unfairly profiting off the core idea of the invention? If so, what about the infringing product—or the infringer—supports that conclusion? Intentions? The nature of the substitution? Some other factor?

2. Why does the DOE exist? According to the Supreme Court, why can’t (or shouldn’t) a utility patent owner be held to the literal scope of their claims?

3. As we’ve seen, prosecution history estoppel is a limit to the DOE. “Another limitation—the doctrine of claim vitiation—ensures that “the application of the doctrine of equivalents is not allowed such broad play as to effectively eliminate a claim element in its entirety.” *Bio-Rad Labs., Inc. v. 10X Genomics Inc.*, 967 F.3d 1353, 1363–64 (Fed. Cir. 2020) (quoting *Warner-Jenkinson Co. v. Hilton Davis Chem. Co.*, 520 U.S. 17, 29 (1997)). According to the Federal Circuit:

“[S]aying that a claim element would be vitiated is akin to saying that there is no equivalent to the claim element in the accused device based on the well-established ‘function-way-result’ or ‘insubstantial differences’ tests.” *Brilliant Instruments, Inc. v. GuideTech, LLC*, 707 F.3d 1342, 1347 (Fed. Cir. 2013). More recently, we have explained that vitiation “is not an exception or threshold determination that forecloses resort to the doctrine of equivalents, but is instead a legal conclusion of a lack of equivalence based on the evidence presented and the theory of equivalence asserted.” *UCB, Inc. v. Watson Labs., Inc.*, 927 F.3d 1272, 1283 (Fed. Cir. 2019) see also *DePuy Spine, Inc. v. Medtronic Sofamor Danek, Inc.*, 469 F.3d 1005, 1017 (Fed. Cir. 2006) (“The ‘all elements’ rule generally is not met—and therefore a claim limitation can be said to be vitiated—if the theory or evidence of equivalence is legally incapable of establishing that the differences between the limitation in the claim and the accused device are insubstantial; *i.e.*, if the theory or evidence is so legally insufficient as to warrant a holding of non-infringement as a matter of law.”).

*Id.* at 1366–67.

4. In *Claiming Intellectual Property*, Jeanne Fromer argues that the DOE is traceable to the practice of “central claiming,” in which patent applicants claimed the core embodiments of their inventions and patent rights extended outward from there. 76 U. CHI. L. REV. 719, 736 (2009). But today, we use a system of “peripheral claiming” for utility patents, where the claims denote the outermost boundaries of what a patent holder claims to have invented. Should the DOE have survived the switch to peripheral claiming? Which of these claiming methods sounds the most predictable to you? The fairest? The most efficient? Does it depend on what type of invention you’re talking about?

### C. Indirect Infringement

Indirect infringement liability derives from tort law’s recognition of secondary liability for actors who assist or encourage others in the commission of a tort. Its roots are in common law. While direct infringement does not rely on knowledge of infringement, courts only find indirect infringement when there are markers of some type of culpability, the contours and content of which we will explore. Indirect infringement liability was codified in the 1952 Act, which allows for liability under separate theories of inducement or contribution.

The common law doctrine allowing for indirect infringement contained requirements of intent and a “primary” act of infringement (generally understood to mean direct infringement). The doctrine was codified in the 1952 Patent Act alongside direct



## INFRINGEMENT

infringement and allows for liability under two related, but distinct theories. Each has its own statutory provision.

The first theory, now known as “contributory infringement,” is defined in the statute as follows:

Whoever sells a component of a patented machine, manufacture, combination or composition, or a material or apparatus for use in practicing a patented process, constituting a material part of the invention, knowing the same to be especially adapted for use in an infringement of such patent and not a staple article or commodity of commerce suitable for substantial noninfringing use, shall be liable as a contributory infringer.

35 U.S.C. § 271(c). Under contributory infringement, there is liability for knowingly offering for sale, selling, or importing a material part of an invention that does not have substantial noninfringing uses. The intuition is that liability can attach for selling or importing something that is an important part of the invention and that is primarily going to be used to infringe. There are limits—the person needs to have some awareness of this fact, and there is an exception for products that have significant alternative uses. Still, the basic idea is to ensure that the patent rights cannot be evaded by selling some material pieces of the invention and letting the buyers do the rest.

The second theory, now known as “inducement,” is defined in the statute as follows: “Whoever actively induces infringement of a patent shall be liable as an infringer.” 35 U.S.C. § 271(b). Inducement infringement was not a separate theory of liability before the 1952 Act. Instead, inducement was a type of evidence for contributory infringement. As a result, there is a great deal of overlap in the assertion of the two theories and in doctrinal application of their requirements.

But the line between direct and indirect infringement is not always a bright one. For example, what happens when a claimed method is performed by more than one entity? Suppose first that two separate people carry out separate steps of a method claim without coordinating with each other at all. In this instance, there is no direct infringement because no one has met all the elements of the claim. Moreover, because indirect infringement liability is only available when there is an underlying act of direct infringement, there is no indirect infringement either. That sounds fair, because in this example, there is no coordination or expectations between the parties. But now suppose that a distributor carries out some of the steps of a method patent and the rest are carried out by a customer. In some ways, this situation resembles cases of indirect infringement, where a distributor may sell a machine that performs an infringing process. But, through a series of Federal Circuit and then Supreme Court cases, the doctrine has developed so that the best way to analyze—or reach—such activities is through claims for direct infringement, with liability

depending on the level of direction and control between the actors, or on whether they form a joint enterprise.

*Aro Manufacturing Co. v. Convertible Top Replacement*  
377 U.S. 476 (1964)

Convertible Top Replacement Co., Inc., (CTR) [was assigned] all rights for the territory of Massachusetts in United States Patent No. 2,569,724, known as the Mackie-Duluk patent. Structures embodying the patented combination were included as original equipment in 1952–1954 models of convertibles manufactured by the General Motors Corporation and the Ford Motor Company. They were included in the General Motors cars by authority of a license granted to General Motors by AB; Ford, however, had no license during the 1952–1954 period, and no authority whatever under the patent until July 21, 1955, when it entered into an agreement, discussed later, with AB; Ford’s manufacture and sale of the automobiles in question therefore infringed the patent. Petitioner Aro Manufacturing Co., Inc. (Aro), which is not licensed under the patent, produces fabric components designed as replacements for wornout fabric portions of convertible tops; unlike the other elements of the topstructure, which ordinarily are usable for the life of the car, the fabric portion normally wears out and requires replacement after about three years of use.

[An earlier Supreme Court opinion (“*Aro I*”) addressed the question of whether Aro’s sales to owners of the GM cars constituted indirect infringement; the Court found that such uses were allowable, noninfringing “repairs” rather than impermissible, infringing “reconstruction” of the convertible tops. In this case, the Court decides whether sales to owners of the (unlicensed) Ford cars constitute indirect infringement.]

I

CTR contends, and the Court of Appeals held, that since Ford infringed the patent by making and selling the top-structures without authority from the patentee, persons who purchased the automobiles from Ford likewise infringed by using and repairing the structures; and hence Aro, by supplying replacement fabrics specially designed to be utilized in such infringing repair, was guilty of contributory infringement under 35 U.S.C. § 271(c). In *Aro I*, the Court said:

It is admitted that petitioners (Aro) know that the purchasers intend to use the fabric for replacement purposes on automobile convertible tops which are covered by the claims of respondent’s combination patent, and such manufacture and sale with that knowledge might well constitute contributory infringement under § 271(c), if, but only if, such a replacement by the purchaser himself would in itself

## INFRINGEMENT

constitute a direct infringement under § 271(a), for it is settled that if there is no direct infringement of a patent there can be no contributory infringement. . . . The determinative question, therefore, comes down to whether the car owner would infringe the combination patent by replacing the worn-out fabric element of the patented convertible top on his car.

Similarly here, to determine whether Aro committed contributory infringement, we must first determine whether the car owners, by replacing the worn-out fabric element of the patented top-structures, committed direct infringement. We think it clear, under § 271(a) of the Patent Code and the “entire body of case law on direct infringement” which [Congress] “left intact,” that they did.

Section 271(a) provides that ‘whoever without authority makes, uses or sells any patented invention infringes the patent.’ It is not controverted – nor could it be – that Ford infringed by making and selling cars embodying the patented top-structures without any authority from the patentee. If Ford had had such authority, its purchasers would not have infringed by using the automobiles, for it is fundamental that sale of a patented article by the patentee or under his authority carries with it an “implied license to use.” But with Ford lacking authority to make and sell, it could by its sale of the cars confer on the purchasers no implied license to use, and their use of the patented structures was thus “without authority” and infringing under § 271(a). Not only does that provision explicitly regard an unauthorized user of a patented invention as an infringer, but it has often and clearly been held that unauthorized use, without more, constitutes infringement.

If the owner’s use infringed, so also did his repair of the top-structure, as by replacing the worn-out fabric component. Where use infringes, repair does also, for it perpetuates the infringing use. . . .

. . .

Consequently replacement of worn-out fabric components with fabrics sold by Aro, held in *Aro I* to constitute “repair” rather than “reconstruction” and thus to be permissible in the case of licensed General Motors cars, was not permissible here in the case of unlicensed Ford cars. Here, as was not the case in *Aro I*, the direct infringement by the car owners that is prerequisite to contributory infringement by Aro was unquestionably established.

We turn next to the question whether Aro, as supplier of replacement fabrics for use in the infringing repair by the Ford car owners, was a contributory infringer under § 271(c) of the Patent Code. That section provides:

Whoever sells a component of a patented machine, manufacture, combination or composition, or a material or apparatus for use in practicing a patented process,

constituting a material part of the invention, knowing the same to be especially made or especially adapted for use in an infringement of such patent, and not a staple article or commodity of commerce suitable for substantial noninfringing use, shall be liable as a contributory infringer.

We think Aro was indeed liable under this provision.

Such a result would plainly have obtained under the contributory-infringement case law that § 271(c) was intended to codify. Indeed, most of the law was established in cases where, as here, suit was brought to hold liable for contributory infringement a supplier of replacement parts specially designed for use in the repair of infringing articles. In *Union Tool Co. v. Wilson*, 259 U.S., at 113-14, the Court held that where use of the patented machines themselves was not authorized,

There was, consequently, no implied license to use the spare parts in these machines. As such use, unless licensed, clearly constituted an infringement, the sale of the spare parts to be so used violated the injunction (enjoining infringement).

...

In enacting § 271(c), Congress clearly succeeded in its objective of codifying this case law. The language of the section fits perfectly Aro's activity of selling "a component of a patented combination, constituting a material part of the invention, especially made or especially adapted for use in an infringement of such patent and not a staple article or commodity of commerce suitable for substantial noninfringing use." Indeed, this is the almost unique case in which the component was hardly suitable for any noninfringing use. On this basis both the District Court originally and the Court of Appeals in the instant case held that Aro was a contributory infringer within the precise letter of § 271(c).

However, the language of § 271(c) presents a question, apparently not noticed by the parties or the courts below, concerning the element of knowledge that must be brought home to Aro before liability can be imposed. It is only sale of a component of a patented combination "knowing the same to be especially made or especially adapted for use in an infringement of such patent" that is contributory infringement under the statute. Was Aro "knowing" within the statutory meaning because—as it admits, and as the lower courts found—it knew that its replacement fabrics were especially designed for use in the 1952–1954 Ford convertible tops and were not suitable for other use? Or does the statute require a further showing that Aro knew that the tops were patented, and knew also that Ford was not licensed under the patent so that any fabric replacement by a Ford car owner constituted infringement?

## INFRINGEMENT

On this question a majority of the Court is of the view that § 271(c) does require a showing that the alleged contributory infringer knew that the combination for which his component was especially designed was both patented and infringing. With respect to many of the replacement-fabric sales involved in this case, Aro clearly had such knowledge. For by letter dated January 2, 1954, AB informed Aro that it held the Mackie-Duluk patent; that it had granted a license under the patent to General Motors but to no one else; and that ‘It is obvious, from the foregoing and from an inspection of the convertible automobile sold by the Ford Motor Company, that anyone selling ready-made replacement fabrics for these automobiles would be guilty of contributory infringement of said patent.’ Thus the Court’s interpretation of the knowledge requirement affords Aro no defense with respect to replacement-fabric sales made after January 2, 1954. It would appear that the overwhelming majority of the sales were in fact made after that date, since the oldest of the cars were 1952 models and since the average life of a fabric top is said to be three years. With respect to any sales that were made before that date, however, Aro cannot be held liable in the absence of a showing that at that time it had already acquired the requisite knowledge that the Ford car tops were patented and infringing. . . .

### Context & Application

1. Knowledge of Infringement: The decision you just read (later referred to as “*Aro II*”) was about contributory infringement. In 2011, the Supreme Court extended *Aro II*’s knowledge requirement to a case about induced infringement:

While both the language of § 271(b) and the pre-1952 case law that this provision was meant to codify are susceptible to conflicting interpretations, our decision in *Aro II* resolves the question in this case. In *Aro II*, a majority held that a violator of § 271(c) must know “that the combination for which his component was especially designed was both patented and infringing,” 377 U.S. at 488, and . . . that conclusion compels this same knowledge for liability under § 271(b) . . . .

While there is much to be said in favor of both views expressed in *Aro II*, the “holding in *Aro II* has become a fixture in the law of contributory infringement under § 271(c),” 5 R. MOY, WALKER ON PATENTS § 15:20, p. 15-131 (4th ed. 2009)—so much so that SEB has not asked us to overrule it. Nor has Congress seen fit to alter § 271(c)’s intent requirement in the nearly half a century since *Aro II* was decided. In light of the special force of the doctrine of stare decisis with regard to questions of statutory interpretation, we proceed on the premise that § 271(c) requires knowledge of the existence of the patent that is infringed.

Based on this premise, it follows that the same knowledge is needed for induced infringement under § 271(b). As noted, the two provisions have a common origin

in the pre-1952 understanding of contributory infringement, and the language of the two provisions creates the same difficult interpretive choice. It would thus be strange to hold that knowledge of the relevant patent is needed under § 271(c) but not under § 271(b).

Accordingly, we now hold that induced infringement under § 271(b) requires knowledge that the induced acts constitute patent infringement.

*Global-Tech Appliances, Inc. v. SEB S.A.*, 563 U.S. 754, 763–66 (2011). The Court then turned to what standard should be applied to determine whether there was knowledge of infringement, finding that the Federal Circuit’s application of “deliberate indifference to a known risk that a patent exists” was not the appropriate standard. Instead, the Court looked to criminal law’s established theory of “willful blindness,” stating:

Many criminal statutes require proof that a defendant acted knowingly or willfully, and courts applying the doctrine of willful blindness hold that defendants cannot escape the reach of these statutes by deliberately shielding themselves from clear evidence of critical facts that are strongly suggested by the circumstances. The traditional rationale for this doctrine is that defendants who behave in this manner are just as culpable as those who have actual knowledge.

...

Given the long history of willful blindness and its wide acceptance in the Federal Judiciary, we can see no reason why the doctrine should not apply in civil lawsuits for induced patent infringement under 35 U.S.C. § 271(b).

Why do you think the Court turned to criminal law to supply this standard? Can you think of any reasons that the criminal law doctrine of willful blindness should not apply in civil lawsuits for induced patent infringement? Justice Kennedy, dissenting, could:

First, the Court appeals to moral theory by citing the “traditional rationale” that willfully blind defendants “are just as culpable as those who have actual knowledge.” But the moral question is a difficult one. Is it true that the lawyer who knowingly suborns perjury is no more culpable than the lawyer who avoids learning that his client, a criminal defendant, lies when he testifies that he was not the shooter? . . . The answer is not obvious. Perhaps the culpability of willful blindness depends on a person’s reasons for remaining blind. Or perhaps only the person’s justification for his conduct is relevant. This is a question of morality and of policy best left to the political branches. Even if one were to accept the substitution of equally blameworthy mental states in criminal cases in light of the retributive purposes of the criminal law, those purposes have no force in the domain of patent law that controls in this case. The Constitution confirms that the

## INFRINGEMENT

purpose of the patent law is a utilitarian one, to “promote the Progress of Science and useful Arts,” Art. I, § 8, cl. 8.

According to Justice Kennedy, the standard should be actual knowledge. Do you find this reasoning persuasive?

2. What if the defendant has a good-faith belief that the patent they’re accused of infringing is invalid? Remember that an invalid patent cannot be infringed. The Court took up that issue in *Commil USA, LLC v. Cisco Systems, Inc.* Justice Kennedy, who dissented in *Global-Tech*, wrote the opinion:

The question the Court confronts today concerns whether a defendant’s belief regarding patent validity is a defense to a claim of induced infringement. It is not. The scienter element for induced infringement concerns infringement; that is a different issue than validity. Section 271(b) requires that the defendant “actively induced infringement.” That language requires intent to “bring about the desired result,” which is infringement. And because infringement and validity are separate issues under the Act, belief regarding validity cannot negate the scienter required under § 271(b).

When infringement is the issue, the validity of the patent is not the question to be confronted. In *Cardinal Chemical Co. v. Morton Int’l, Inc.*, 508 U.S. 83 (1993), the Court explained, “A party seeking a declaratory judgment of invalidity presents a claim independent of the patentee’s charge of infringement.” It further held noninfringement and invalidity were “alternative grounds” for dismissing the suit. And in *Deposit Guaranty Nat. Bank v. Roper*, 445 U. S. 326, 334 (1980), the Court explained that an accused infringer “may prevail either by successfully attacking the validity of the patent or by successfully defending the charge of infringement.” These explanations are in accord with the long-accepted truth—perhaps the axiom—that infringement and invalidity are separate matters under patent law.

Indeed, the issues of infringement and validity appear in separate parts of the Patent Act. Part III of the Act deals with “Patents and Protection of Patent Rights,” including the right to be free from infringement. §§ 251-329. Part II, entitled “Patentability of Inventions and Grants of Patents,” defines what constitutes a valid patent. §§ 100-212. Further, noninfringement and invalidity are listed as two separate defenses, see §§ 282(b)(1), (2), and defendants are free to raise either or both of them. Were this Court to interpret § 271(b) as permitting a defense of belief in invalidity, it would conflate the issues of infringement and validity.

Allowing this new defense would also undermine a presumption that is a “common core of thought and truth” reflected in this Court’s precedents for a century. Under the Patent Act, and the case law before its passage, a patent is

“presumed valid.” § 282(a). That presumption takes away any need for a plaintiff to prove his patent is valid to bring a claim. But if belief in invalidity were a defense to induced infringement, the force of that presumption would be lessened to a drastic degree, for a defendant could prevail if he proved he reasonably believed the patent was invalid. That would circumvent the high bar Congress is presumed to have chosen: the clear and convincing standard. Defendants must meet that standard to rebut the presumption of validity.

To say that an invalid patent cannot be infringed, or that someone cannot be induced to infringe an invalid patent, is in one sense a simple truth, both as a matter of logic and semantics. But the questions courts must address when interpreting and implementing the statutory framework require a determination of the procedures and sequences that the parties must follow to prove the act of wrongful inducement and any related issues of patent validity. . . . To be sure, if at the end of the day, an act that would have been an infringement or an inducement to infringe pertains to a patent that is shown to be invalid, there is no patent to be infringed. But the allocation of the burden to persuade on these questions, and the timing for the presentations of the relevant arguments, are concerns of central relevance to the orderly administration of the patent system.

Invalidity is an affirmative defense that “can preclude enforcement of a patent against otherwise infringing conduct.” 6A CHISUM ON PATENTS § 19.01, at 19-5 (2015). An accused infringer can, of course, attempt to prove that the patent in suit is invalid; if the patent is indeed invalid, and shown to be so under proper procedures, there is no liability. That is because invalidity is not a defense to infringement, it is a defense to liability. And because of that fact, a belief as to invalidity cannot negate the scienter required for induced infringement.

There are also practical reasons not to create a defense based on a good-faith belief in invalidity. First and foremost, accused inducers who believe a patent is invalid have various proper ways to obtain a ruling to that effect. They can file a declaratory judgment action asking a federal court to declare the patent invalid. They can seek inter partes review at the Patent Trial & Appeal Board and receive a decision as to validity within 12 to 18 months. See § 316. Or they can, as Cisco did here, seek ex parte reexamination of the patent by the [USPTO]. § 302. And, of course, any accused infringer who believes the patent in suit is invalid may raise the affirmative defense of invalidity. § 282(b)(2). If the defendant is successful, he will be immune from liability.

Creating a defense of belief in invalidity, furthermore, would have negative consequences. It can render litigation more burdensome for everyone involved. Every accused inducer would have an incentive to put forth a theory of invalidity



## INFRINGEMENT

and could likely come up with myriad arguments. And since “it is often more difficult to determine whether a patent is valid than whether it has been infringed,” accused inducers would likely find it easier to prevail on a defense regarding the belief of invalidity than noninfringement. In addition the need to respond to the defense will increase discovery costs and multiply the issues the jury must resolve. Indeed, the jury would be put to the difficult task of separating the defendant’s belief regarding validity from the actual issue of validity.

575 U.S. 632 (2015). Do you agree that there should be a distinction between a good faith belief in non-infringement (which is a defense to indirect infringement) and a good faith belief in invalidity (which is not)? For an argument that method claims are afforded less protection than patents on products in the context of what has come to be known as “divided infringement,” see Timothy R. Holbrook, *Method Patent Exceptionalism*, 102 IOWA L. REV. 1001, 1047 (2017).

3. Indirect infringement is one area where notions of knowledge and culpability play a role in determining infringement. In general, patent infringement is often referred to as a “strict liability” tort, because it requires no knowledge of the infringement for liability to attach. For an argument that patent infringement is more akin to an intentional tort, requiring intent to perform the act, but not intent to infringe another’s rights, see Saurabh Vishnubhakat, *An Intentional Tort Theory of Patents*, 68 FLA. L. REV. 571 (2016).

*C.R. Bard, Inc. v. Advanced Cardiovascular Systems, Inc.*  
911 F.2d 670 (Fed. Cir. 1990)

PLAGER, Circuit Judge.

This is a case of claimed infringement of a method patent for a medical treatment. Defendant–Appellant Advanced Cardiovascular Systems, Inc. (ACS) was marketing the only perfusion catheter approved by the United States Food and Drug Administration for use in coronary angioplasty. Plaintiff–Appellee C.R. Bard, Inc. (Bard) sued ACS for alleged infringement of U.S. Patent No. 4,581,017 (’017), application for which was filed in 1983 and which issued to Harvinder Sahota in 1986; Bard had purchased all rights to the ’017 patent as of December 31, 1986. The ’017 patent relates to a method for using a catheter in coronary angioplasty. On July 28, 1989, the United States District Court for the Central District of California granted plaintiff Bard summary judgment against ACS determining that the ’017 patent was not invalid as obvious, and finding infringement of claim 1 of the ’017 patent. We reverse the grant of summary judgment and remand the case for further proceedings.

## CHAPTER 9

### I

#### A

In the human circulatory system, the left ventricle of the heart pumps blood into the aorta, the body's largest artery, which then distributes the blood to smaller arteries throughout the body. The first arteries to branch off from the aorta are the left and right main coronary arteries, which provide blood to the heart muscle itself.

Atherosclerosis may cause these arteries to be progressively narrowed (stenosis) by the formation of plaque within the arteries resulting in coronary artery disease. This decreases blood flow to the heart muscle and may cause problems ranging from chest pain (angina) to, in the extreme, a fatal heart attack (myocardial infarction).

Bypass surgery allows the grafting of a vein to the affected coronary artery to bypass the stenosis. Percutaneous transluminal coronary angioplasty (PTCA), an alternative procedure, involves inserting a deflated balloon dilation catheter through the patient's arteries to reach the stenosis in the coronary artery. The balloon is inflated to dilate the stenosis and then deflated and removed to restore blood flow to the heart.

A difficulty associated with PTCA is that a prolonged blockage of blood flow to the heart muscle in the course of the procedure, caused by the inflated balloon, may itself result in angina or a heart attack. Typically during a PTCA, repeated inflations of the balloon, each lasting from 60–90 seconds, are performed.

### B

U.S. Patent No. 4,423,725 ('725), filed in 1982 and issued in 1984, discloses a catheter having a multiple surgical cuff with an inflatable cuff member, and having a central lumen or channel containing side window openings in fluid communication with the central lumen. The side openings allow blood to circulate through the central lumen even while the inflatable cuff is inflated, thus avoiding blockage of fluid flow when the cuff member is inflated. The '725 patent discloses that, in an angioplasty, "the side openings ... should be located at the level of the aorta to create the highest blood pressure and to prevent the side openings from being closed laterally by an adherent small artery wall."

In 1983, inventor Sahota filed a patent application (ultimately issuing as the '017 patent, the patent at issue in this case) having (1) device claims for a catheter to administer an angioplasty treatment and (2) method claims for the manner in which a surgeon would use the catheter in administration of an angioplasty treatment. All claims were rejected by the patent examiner. In particular, claim 4 of the application (which, following significant amendment, became claim 1 of the '017 patent) was rejected, *inter alia*, in view of the prior art '725 patent.

## INFRINGEMENT

Following this rejection, the inventor modified certain claims. These modified claims were also rejected. Following this rejection, the inventor removed all claims to a catheter, and claimed only a method of administering an angioplasty.

In twice amending claim 4 of the application, the inventor argued to the examiner that “the proximal orifices which admit blood to the main lumen in the blood catheter are ‘*immediately adjacent said balloon.*’” Claim 4 of the application was ultimately allowed as claim 1 of the '017 patent, and contained the “immediately adjacent” language.

### C

The ACS catheter, sold under the name ACS Stack Perfusion Catheter, is a balloon-type catheter having side openings in the main lumen located near the proximal end of the balloon. The ACS catheter’s main lumen is simply open past the distal end of the balloon enabling blood to flow through the catheter while the balloon is inflated. Plaintiff Bard alleges that the ACS catheter is especially adapted for use by a surgeon in the course of administering a coronary angioplasty in a manner that infringes claim 1 of the '017 patent, that therefore ACS is a contributory infringer, and that ACS actively induces infringement.

ACS denied both charges and challenged the validity of the Bard patent. The district judge agreed with Bard and granted Bard’s request for summary judgment, finding ACS to have “actively induced or contributed to [the] infringement” of claim 1 of the '017 patent, and to have failed to prove the invalidity of the '017 patent.

### II

### B

Bard alleges that under 35 U.S.C. § 271(b), (c) (1988), ACS has both (1) induced infringement of method claim 1 in the '017 patent and (2) contributorily infringed. Of course, a finding of induced or contributory infringement must be predicated on a direct infringement of claim 1 by the users of the ACS catheter.

### 1

Bard argues that by selling its catheter for use by surgeons in angioplasty procedures, ACS is a contributory infringer of Bard’s method claim 1 in the '017 patent. Section 271 of Title 35, United States Code, deals with infringement of patents; subsection (c) specifies what is necessary to be a contributory infringer. For purposes of this case, the statute requires that ACS sell a catheter for use in practicing the '017 process, which use constitutes a material part of the invention, knowing that the catheter is especially made or adapted for use in infringing the patent, and that the catheter is not a staple article or commodity of commerce suitable for substantial noninfringing use.

## CHAPTER 9

In asserting ACS's contributory infringement of claim 1, Bard seeks to establish the requisite direct infringement by arguing that there is no evidence that any angioplasty procedures using the ACS catheter would be noninfringing. Testing this assertion requires a two step analysis. First is a determination of the scope of the claim at issue. Second is an examination of the evidence before the court to ascertain whether, under § 271(c), use of the ACS catheter would infringe the claim as interpreted.

Claim 1 of the '017 patent claims, *inter alia*,

[a] method of administering an angioplasty treatment to a patient to produce acceptable blood flow in a stenotic region of a coronary artery having restricted blood flow, comprising:

inserting a tube having an outer surface enclosing a main lumen terminating in a main axial orifice into said coronary artery . . .

channeling blood flow through the wall of said proximal portion of said main lumen immediately adjacent said balloon to fluidly connect locations within said coronary artery surrounding said proximal and distal portions of said tube while said balloon is inflated within said coronary artery to conduct blood downstream from the portion of said coronary artery occluded by the inflated balloon.

Bard argues that the prior art '725 patent teaches the use of the catheter with the inlets (side openings) where the blood enters the tube placed only in the aorta, whereas the '017 method in suit involves insertion of the catheter into the coronary artery in such a manner that the openings "immediately adjacent [to] the balloon fluidly connect locations within the coronary artery surrounding the proximal and distal portions of the tube." Thus, Bard argues, a surgeon, inserting the ACS catheter into a coronary artery to a point where an inlet at the catheter's proximal end draws blood from the artery, infringes the '017 patent.

To fully understand this difference, it is important to note that the ACS catheter has a series of ten openings in the tube near, and at the proximal end of, the balloon. The first of these openings—the one closest to the balloon—is approximately six millimeters (less than ¼ inch) from the edge of the proximal end of the balloon. The remainder are located along the main lumen at intervals, the furthest from the balloon being 6.3 centimeters (approximately 2 ½ inches) away.

It would appear that three possible fact patterns may arise in the course of using the ACS catheter during a PTCA. The first pattern involves positioning the catheter such that all of its side openings are located only in the aorta. This is clearly contemplated by the prior art '725 patent cited by the examiner; claims to this method were expressly given up by inventor Sahota during patent prosecution and are not now available to Bard.

## INFRINGEMENT

In the second of the possible fact patterns, all of the side openings are located within the coronary artery. This situation appears to have been contemplated by the '017 patent, the method patent at issue. In this situation, it correctly can be said that blood flowing through the main lumen will "fluidly connect locations within the coronary artery surrounding the proximal and distal portions of the tube."

In the third fact pattern, some of the side openings are located in the aorta and some are located in the artery. The trial judge concluded,

[t]hat ACS has added extra holes further from the balloon does not affect the conclusion of infringement, as the patent does not require that all holes be "immediately adjacent" the balloon, nor that the blood flowing through the balloon come solely from the coronary artery.

There is evidence in the record that 40 to 60 percent of the stenoses that require angioplasty are located less than three centimeters from the entrance to the coronary artery. ACS argues that therefore the ACS catheter may be used in such a way that all of the openings are located in the aorta. Even assuming that the trial judge's conclusion is correct that claim 1 is applicable to the third of the fact patterns, it remains true that on this record a reasonable jury could find that, pursuant to the procedure described in the first of the fact patterns (a noninfringing procedure), there are substantial noninfringing uses for the ACS catheter.

Whether the ACS catheter "has no use except through practice of the patented method," is thus a critical issue to be decided in this case. As the Supreme Court recently noted, "when a charge of contributory infringement is predicated entirely on the sale of an article of commerce that is used by the purchaser allegedly to infringe a patent, the public interest in access to that article of commerce is necessarily implicated." *Sony Corp. v. Universal City Studios, Inc.*, 464 U.S. 417, 440 (1983). Viewing the evidence in this case in a light most favorable to the nonmoving party, and resolving reasonable inferences in ACS's favor, it cannot be said that Bard is entitled to judgment as a matter of law. The grant of summary judgment finding ACS a contributory infringer under § 271(c) is not appropriate.

2

A person induces infringement under § 271(b) by actively and knowingly aiding and abetting another's direct infringement. Bard argues that ACS induced infringement under § 271(b) by: 1) providing detailed instructions and other literature on how to use its catheter in a manner which would infringe claim 1; and 2) having positioned the inlets near the balloon's proximal end so as to allow a user of the ACS catheter to infringe claim 1. As already discussed, on a motion for summary judgment we view the evidence in a light most favorable to ACS, the nonmoving party, and draw all reasonable inferences in

its favor. The evidence before the trial judge on the motion for summary judgment was at best ambiguous regarding the fact pattern or patterns under which the catheter was to be used. Because a genuine issue of material fact thus exists, a grant of summary judgment finding ACS induced infringement is also not appropriate.

### Context & Application

1. In *C.R. Bard*, the Federal Circuit quotes and relies on a copyright case, *Sony Corp. v. Universal City Studios, Inc.*, for a proposition about contributory infringement. Unlike the Patent Act, the Copyright Act does not mention contributory or inducement liability. It does not create a cause of action for contributory infringement. But in *Sony*, the Court read one into the statute and imported the concept of a “staple article of commerce” from the Patent Act into copyright law. See 464 U.S. 417, 440–42 (1983). The Court built on *Sony* in the copyright case *Metro–Goldwyn–Mayer Studios Inc. v. Grokster, Ltd.*, 545 U.S. 913 (2005), which the Court then relied upon in the patent case *Global-Tech Appliances, Inc. v. SEB S.A.*, 563 U.S. 754, 763 (2011). What do you think about this kind of doctrinal cross-pollination? What does it mean for your research responsibilities and the potential arguments you could make if you were working on a patent contributory liability case?

### D. Joint Infringement

*Limelight Networks, Inc. v. Akamai Technologies, Inc.*,  
572 U.S. 915 (2014)

Justice ALITO delivered the opinion of the Court.

This case presents the question whether a defendant may be liable for inducing infringement of a patent under 35 U.S.C. § 271(b) when no one has directly infringed the patent under § 271(a) or any other statutory provision. . . .

I

A

Respondent the Massachusetts Institute of Technology is the assignee of U.S. Patent No. 6,108,703 (‘703 patent), which claims a method of delivering electronic data using a “content delivery network,” or “CDN.” Respondent Akamai Technologies, Inc., is the exclusive licensee. Akamai maintains many servers distributed in various locations. Proprietors of Web sites, known as “content providers,” contract with Akamai to deliver their Web sites’ content to individual Internet users. The ‘703 patent provides for the designation of certain components of a content provider’s Web site (often large files, such

## INFRINGEMENT

as video or music files) to be stored on Akamai's servers and accessed from those servers by Internet users. The process of designating components to be stored on Akamai's servers is known as "tagging." By "aggregating the data demands of multiple content providers with differing peak usage patterns and serving that content from multiple servers in multiple locations," as well as by delivering content from servers located in the same geographic area as the users who are attempting to access it, Akamai is able to increase the speed with which Internet users access the content of its customers' Web sites.

Petitioner Limelight Networks, Inc., also operates a CDN and carries out several of the steps claimed in the '703 patent. But instead of tagging those components of its customers' Web sites that it intends to store on its servers (a step included in the '703 patent), Limelight requires its customers to do their own tagging. Respondents claim that Limelight "provides instructions and offers technical assistance" to its customers regarding how to tag, but the record is undisputed that Limelight does not tag the components to be stored on its servers.

### B

In 2006, respondents sued Limelight in the United States District Court for the District of Massachusetts, claiming '919 patent infringement. The case was tried to a jury, which found that Limelight had committed infringement and awarded more than \$40 million in damages.

Respondents' victory was short-lived, however. After the jury returned its verdict, the Federal Circuit decided *Muniauction, Inc. v. Thomson Corp.*, 532 F.3d 1318 (2008). In that case the Court of Appeals rejected a claim that the defendant's method, involving bidding on financial instruments using a computer system, directly infringed the plaintiff's patent. The defendant performed some of the steps of the patented method, and its customers, to whom the defendant gave access to its system along with instructions on the use of the system, performed the remaining steps. The court started from "the proposition that direct infringement requires a single party to perform every step of a claimed method." This requirement is satisfied even though the steps are actually undertaken by multiple parties, the court explained, if a single defendant "exercises 'control or direction' over the entire process such that every step is attributable to the controlling party." The court held that the defendant in *Muniauction* was not liable for direct infringement because it did not exercise control or direction over its customers' performance of those steps of the patent that the defendant itself did not perform.

In light of *Muniauction*, Limelight moved for reconsideration of its earlier motion for judgment as a matter of law, which the District Court had denied. The District Court granted the motion, concluding that *Muniauction* precluded a finding of direct infringement under § 271(a) because infringement of the '703 patent required tagging and

Limelight does not control or direct its customers' tagging. A panel of the Federal Circuit affirmed, explaining that a defendant that does not itself undertake all of a patent's steps can be liable for direct infringement only "when there is an agency relationship between the parties who perform the method steps or when one party is contractually obligated to the other to perform the steps." Since neither of these conditions was met in the present case, the Federal Circuit panel held that Limelight could not be held liable for direct infringement.

The Federal Circuit granted *en banc* review and reversed. The *en banc* court found it unnecessary to revisit its § 271(a) direct infringement case law. Instead, it concluded that the "evidence could support a judgment in respondents' favor on a theory of induced infringement" under § 271(b). This was true, the court explained, because § 271(b) liability arises when a defendant carries out some steps constituting a method patent and encourages others to carry out the remaining steps—even if no one would be liable as a direct infringer in such circumstances, because those who performed the remaining steps did not act as agents of, or under the direction or control of, the defendant. The Court of Appeals did not dispute that "there can be no indirect infringement without direct infringement," but it explained that "requiring proof that there has been direct infringement is not the same as requiring proof that a single party would be liable as a direct infringer". Judge Newman and Judge Linn both dissented (with the latter joined by Judges Dyk, Prost, and O'Malley).

Limelight sought certiorari, which we granted.

## II

### A

Neither the Federal Circuit, nor respondents dispute the proposition that liability for inducement must be predicated on direct infringement. This is for good reason, as our case law leaves no doubt that inducement liability may arise "if, but only if, there is direct infringement." *Aro Mfg. Co. v. Convertible Top Replacement Co.*, 365 U.S. 336, (1961).

One might think that this simple truth is enough to dispose of this appeal. But the Federal Circuit reasoned that a defendant can be liable for inducing infringement under § 271(b) even if no one has committed direct infringement within the terms of § 271(a) (or any other provision of the patent laws), because direct infringement can exist independently of a violation of these statutory provisions.

The Federal Circuit's analysis fundamentally misunderstands what it means to infringe a method patent. A method patent claims a number of steps; under this Court's case law, the patent is not infringed unless all the steps are carried out. *See, e.g., Aro* (a "patent covers only the totality of the elements in the claim and ... no element, separately



viewed, is within the grant”). This principle follows ineluctably from what a patent is: the conferral of rights in a particular claimed set of elements. “Each element contained in a patent claim is deemed material to defining the scope of the patented invention,” *Warner–Jenkinson Co. v. Hilton Davis Chemical Co.*, 520 U.S. 17, 29 (1997), and a patentee’s rights extend only to the claimed combination of elements, and no further.

The Federal Circuit held in *Muniauction* that a method’s steps have not all been performed as claimed by the patent unless they are all attributable to the same defendant, either because the defendant actually performed those steps or because he directed or controlled others who performed them. Assuming without deciding that the Federal Circuit’s holding in *Muniauction* is correct, there has simply been no infringement of the method in which respondents have staked out an interest, because the performance of all the patent’s steps is not attributable to any one person. And, as both the Federal Circuit and respondents admit, where there has been no direct infringement, there can be no inducement of infringement under § 271(b).

The Federal Circuit’s contrary view would deprive § 271(b) of ascertainable standards. If a defendant can be held liable under § 271(b) for inducing conduct that does not constitute infringement, then how can a court assess when a patent holder’s rights have been invaded? What if a defendant pays another to perform just one step of a 12–step process, and no one performs the other steps, but that one step can be viewed as the most important step in the process? In that case the defendant has not encouraged infringement, but no principled reason prevents him from being held liable for inducement under the Federal Circuit’s reasoning, which permits inducement liability when fewer than all of a method’s steps have been performed within the meaning of the patent. The decision below would require the courts to develop two parallel bodies of infringement law: one for liability for direct infringement, and one for liability for inducement.

Section 271(f)(1) reinforces our reading of § 271(b). That subsection imposes liability on a party who “supplies or causes to be supplied in or from the United States all or a substantial portion of the components of a patented invention in such manner as to actively induce the combination of such components outside of the United States in a manner that would infringe the patent if such combination occurred within the United States.” As this provision illustrates, when Congress wishes to impose liability for inducing activity that does not itself constitute direct infringement, it knows precisely how to do so. The courts should not create liability for inducement of non-infringing conduct where Congress has elected not to extend that concept.

The Federal Circuit seems to have adopted the view that *Limelight* induced infringement on the theory that the steps that *Limelight* and its customers perform would infringe the ’703 patent if all the steps were performed by the same person. But we have

## CHAPTER 9

already rejected the notion that conduct which would be infringing in altered circumstances can form the basis for contributory infringement, and we see no reason to apply a different rule for inducement. . . . In this case, performance of all the claimed steps cannot be attributed to a single person, so direct infringement never occurred. Limelight cannot be liable for inducing infringement that never came to pass.

### III

Respondents ask us to review the merits of the Federal Circuit's *Muniauction* rule for direct infringement under § 271(a). We decline to do so today.

In the first place, the question presented is clearly focused on § 271(b), not § 271(a). We granted certiorari on the following question: "Whether the Federal Circuit erred in holding that a defendant may be held liable for inducing patent infringement under 35 U.S.C. § 271(b) even though no one has committed direct infringement under § 271(a)." The question presupposes that Limelight has not committed direct infringement under § 271(a). And since the question on which we granted certiorari did not involve § 271(a), petitioner did not address that important issue in its opening brief. Our decision on the § 271(b) question necessitates a remand to the Federal Circuit, and on remand, the Federal Circuit will have the opportunity to revisit the § 271(a) question if it so chooses.

### IV

The judgment below is reversed, and the case is remanded for further proceedings consistent with this opinion.

## Context & Application

1. The issue of joint infringement does not fit squarely as indirect or direct infringement. Like much indirect infringement, the alleged infringing activity in *Limelight* involved facilitation by a company and then action by a customer. Unlike a classic case of indirect infringement, each entity carried out some portion of the steps of the method claim. However, there can be no indirect infringement without an underlying act of direct infringement. At the same time, direct infringement didn't fit the facts because of the rule from *Muniauction* requiring that a single party perform all the steps of a method patent in order for there to be direct infringement. The Court indicated that it was this rule that complicated things for the patent holder. The case was remanded to the Federal Circuit, which clarified its test for when acts may be attributed to another party:

Direct infringement under § 271(a) occurs where all steps of a claimed method are performed by or attributable to a single entity. Where more than one actor is involved in practicing the steps, a court must determine whether the acts of one are attributable to the other such that a single entity is responsible for the

## INFRINGEMENT

infringement. We will hold an entity responsible for others' performance of method steps in two sets of circumstances: (1) where that entity directs or controls others' performance, and (2) where the actors form a joint enterprise.

To determine if a single entity directs or controls the acts of another, we continue to consider general principles of vicarious liability. In the past, we have held that an actor is liable for infringement under § 271(a) if it acts through an agent (applying traditional agency principles) or contracts with another to perform one or more steps of a claimed method. We conclude, on the facts of this case, that liability under § 271(a) can also be found when an alleged infringer conditions participation in an activity or receipt of a benefit upon performance of a step or steps of a patented method and establishes the manner or timing of that performance. In those instances, the third party's actions are attributed to the alleged infringer such that the alleged infringer becomes the single actor chargeable with direct infringement. Whether a single actor directed or controlled the acts of one or more third parties is a question of fact, reviewable on appeal for substantial evidence, when tried to a jury.

Alternatively, where two or more actors form a joint enterprise, all can be charged with the acts of the other, rendering each liable for the steps performed by the other as if each is a single actor. *See* RESTATEMENT (SECOND) OF TORTS § 491 cmt. b ("The law considers that each is the agent or servant of the others, and that the act of any one within the scope of the enterprise is to be charged vicariously against the rest."). A joint enterprise requires proof of four elements:

- (1) an agreement, express or implied, among the members of the group;
- (2) a common purpose to be carried out by the group;
- (3) a community of pecuniary interest in that purpose, among the members; and
- (4) an equal right to a voice in the direction of the enterprise, which gives an equal right of control.

As with direction or control, whether actors entered into a joint enterprise is a question of fact, reviewable on appeal for substantial evidence.

We believe these approaches to be most consistent with the text of § 271(a), the statutory context in which it appears, the legislative purpose behind the Patent Act, and our past case law. Section 271(a) is not limited solely to principal-agent relationships, contractual arrangements, and joint enterprise, as the vacated panel decision held. Rather, to determine direct infringement, we consider whether all method steps can be attributed to a single entity.

*Akamai Tech. v. Limelight*, 797 F.3d 1020 (Fed. Cir. 2015). The Federal Circuit then found there were substantial facts from which a jury could conclude that Limelight directed or controlled its customers' performance of steps, such that those steps could be attributed to Limelight itself and that the verdict of direct infringement was supported.

## E. Cross-border Infringement

Cross-border cases include the import and export of information and goods at various stages of production. When acts take place in separate locations or the claim elements are not satisfied entirely within one country, U.S. courts must decide whether domestic rights have in fact been infringed. Cross-border infringement expansion is similar to the doctrine of equivalents and indirect infringement doctrines because fairness interests for patent holders conflict with the interests of bounding patent rights—and thereby the application of infringement.

Congress has expanded infringement liability to include the manufacture of components in the United States that are assembled abroad into a device that would infringe a U.S. patent if assembled within the United States. Congress has also expanded infringement liability for imports that were manufactured through a method that, if performed in the United States, would constitute infringement of a U.S. patent. And courts have faced other complicated questions in determining when infringement of a U.S. patent have occurred when a step of a patented method is performed outside the United States or when offers for sale and sales are made such that one is in the United States and the other is outside.

Imagine a manufacturer makes all the components of a patented shrimp deveining machine in the United States, but the combination is not assembled or sold domestically; rather, the components are sent abroad to be combined and sold elsewhere. Should this company be liable for infringement of a U.S. patent? A company that manufactured and combined the components in the United States would infringe the U.S. patent, even if the goods were subsequently exported, because it is direct infringement to “make” a patented invention without authority in the United States. In a 1972 case called *Deepsouth Packing Co. v. Laitram Corp.*, the Court held that the United States patent was not infringed by the manufacture and export of the un-combined components, based on the theory that U.S. laws do not apply extra-territorially, and the combination only happened outside of the country.

Congress moved to remedy this seeming loophole in 1984, enacting § 271(f) of the Patent Act, the first paragraph of which declared it an act of patent infringement to “suppl[y] . . . in or from the United States all or a substantial portion of the components of a patented invention, where such components are uncombined in whole or in part, in

## INFRINGEMENT

such manner as to actively induce the combination of such components outside the United States.” Section 271(f) has a second paragraph that is targeted to the export of any component (rather than “all or a substantial portion of the components”) of a patented invention “that is especially made or especially adapted for use in the invention and not a staple article or commodity of commerce suitable for substantial noninfringing use . . . .”

*Microsoft, Corp. v. AT&T Corp.*  
550 U.S. 437 (2007)

Justice GINSBURG delivered the opinion of the Court.

It is the general rule under United States patent law that no infringement occurs when a patented product is made and sold in another country. There is an exception. Section 271(f) of the Patent Act, adopted in 1984, provides that infringement does occur when one “supplies from the United States,” for “combination” abroad, a patented invention’s “components.” 35 U.S.C. § 271(f)(1). This case concerns the applicability of § 271(f) to computer software first sent from the United States to a foreign manufacturer on a master disk, or by electronic transmission, then copied by the foreign recipient for installation on computers made and sold abroad.

AT&T holds a patent on an apparatus for digitally encoding and compressing recorded speech. Microsoft’s Windows operating system, it is conceded, has the potential to infringe AT&T’s patent, because Windows incorporates software code that, when installed, enables a computer to process speech in the manner claimed by that patent. It bears emphasis, however, that uninstalled Windows software does not infringe AT&T’s patent any more than a computer standing alone does; instead, the patent is infringed only when a computer is loaded with Windows and is thereby rendered capable of performing as the patented speech processor. The question before us: Does Microsoft’s liability extend to computers made in another country when loaded with Windows software copied abroad from a master disk or electronic transmission dispatched by Microsoft from the United States? Our answer is “No.”

The master disk or electronic transmission Microsoft sends from the United States is never installed on any of the foreign-made computers in question. Instead, copies made abroad are used for installation. Because Microsoft does not export from the United States the copies actually installed, it does not “supply from the United States” “components” of the relevant computers, and therefore is not liable under § 271(f) as currently written.

Plausible arguments can be made for and against extending § 271(f) to the conduct charged in this case as infringing AT&T’s patent. Recognizing that § 271(f) is an exception to the general rule that our patent law does not apply extraterritorially, we resist giving

the language in which Congress cast § 271(f) an expansive interpretation. Our decision leaves to Congress' informed judgment any adjustment of § 271(f) it deems necessary or proper.

## I

Our decision some 35 years ago in *Deepsouth Packing Co. v. Laitram Corp.*, 406 U.S. 518 (1972), a case about a shrimp deveining machine, led Congress to enact § 271(f). In that case, Laitram, holder of a patent on the time-and-expense-saving machine, sued Deepsouth, manufacturer of an infringing deveiner. Deepsouth conceded that the Patent Act barred it from making and selling its deveining machine in the United States, but sought to salvage a portion of its business: Nothing in United States patent law, Deepsouth urged, stopped it from making in the United States the *parts* of its deveiner, as opposed to the machine itself, and selling those *parts* to foreign buyers for assembly and use abroad. We agreed.

Interpreting our patent law as then written, we reiterated in *Deepsouth* that it was “not an infringement to make or use a patented product outside of the United States.” Deepsouth’s foreign buyers did not infringe Laitram’s patent, we held, because they assembled and used the deveining machines outside the United States. Deepsouth, we therefore concluded, could not be charged with inducing or contributing to an infringement. Nor could Deepsouth be held liable as a direct infringer, for it did not make, sell, or use the patented invention—the fully assembled deveining machine—within the United States. The parts of the machine were not themselves patented, we noted, hence export of those parts, unassembled, did not rank as an infringement of Laitram’s patent.

Laitram had argued in *Deepsouth* that resistance to extension of the patent privilege to cover exported parts “derived from too narrow and technical an interpretation of the Patent Act.” Rejecting that argument, we referred to prior decisions holding that “a combination patent protects only against the operable assembly of the whole and not the manufacture of its parts.” Congress’ codification of patent law, we said, signaled no intention to broaden the scope of the privilege. And we again emphasized that “our patent system makes no claim to extraterritorial effect; these acts of Congress do not, and were not intended to, operate beyond the limits of the United States; and we correspondingly reject the claims of others to such control over our markets.” Absent “a clear congressional indication of intent,” we stated, courts had no warrant to stop the manufacture and sale of the parts of patented inventions for assembly and use abroad.

Focusing its attention on *Deepsouth*, Congress enacted § 271(f). The provision expands the definition of infringement to include supplying from the United States a patented invention’s components:

## INFRINGEMENT

(1) Whoever without authority supplies or causes to be supplied in or from the United States all or a substantial portion of the components of a patented invention, where such components are uncombined in whole or in part, in such manner as to actively induce the combination of such components outside of the United States in a manner that would infringe the patent if such combination occurred within the United States, shall be liable as an infringer.

(2) Whoever without authority supplies or causes to be supplied in or from the United States any component of a patented invention that is especially made or especially adapted for use in the invention and not a staple article or commodity of commerce suitable for substantial noninfringing use, where such component is uncombined in whole or in part, knowing that such component is so made or adapted and intending that such component will be combined outside of the United States in a manner that would infringe the patent if such combination occurred within the United States, shall be liable as an infringer.

## II

Windows is designed, authored, and tested at Microsoft's Redmond, Washington, headquarters. Microsoft sells Windows to end users and computer manufacturers, both foreign and domestic. Purchasing manufacturers install the software onto the computers they sell. Microsoft sends to each of the foreign manufacturers a master version of Windows, either on a disk or via encrypted electronic transmission. The manufacturer uses the master version to generate copies. Those copies, not the master sent by Microsoft, are installed on the foreign manufacturer's computers. Once assembly is complete, the foreign-made computers are sold to users abroad.<sup>4</sup>

<sup>4</sup> Microsoft also distributes Windows to foreign manufacturers indirectly, by sending a master version to an authorized foreign "replicator"; the replicator then makes copies and ships them to the manufacturers.

AT&T's patent ('580 patent) is for an apparatus (as relevant here, a computer) capable of digitally encoding and compressing recorded speech. Windows, the parties agree, contains software that enables a computer to process speech in the manner claimed by the '580 patent. In 2001, AT&T filed an infringement suit in the United States District Court for the Southern District of New York, charging Microsoft with liability for domestic and foreign installations of Windows.

Neither Windows software (*e.g.*, in a box on the shelf) nor a computer standing alone (*i.e.*, without Windows installed) infringes AT&T's patent. Infringement occurs only when Windows is installed on a computer, thereby rendering it capable of performing as the patented speech processor. Microsoft stipulated that by installing Windows on its own computers during the software development process, it directly infringed the '580 patent.

Microsoft further acknowledged that by licensing copies of Windows to manufacturers of computers sold in the United States, it induced infringement of AT&T's patent.

Microsoft denied, however, any liability based on the master disks and electronic transmissions it dispatched to foreign manufacturers, thus joining issue with AT&T. By sending Windows to foreign manufacturers, AT&T contended, Microsoft "supplied from the United States," for "combination" abroad, "components" of AT&T's patented speech processor; accordingly, AT&T urged, Microsoft was liable under § 271(f). Microsoft responded that unincorporated software, because it is intangible information, cannot be typed a "component" of an invention under § 271(f). In any event, Microsoft urged, the foreign-generated copies of Windows actually installed abroad were not "supplied from the United States." Rejecting these responses, the District Court held Microsoft liable under § 271(f). On appeal, a divided panel of the Court of Appeals for the Federal Circuit affirmed. We granted certiorari and now reverse.

### III

#### A

This case poses two questions: First, when, or in what form, does software qualify as a "component" under § 271(f)? Second, were "components" of the foreign-made computers involved in this case "supplied" by Microsoft "from the United States"?

As to the first question, no one in this litigation argues that software can *never* rank as a "component" under § 271(f). The parties disagree, however, over the stage at which software becomes a component. Software, the "set of instructions, known as code, that directs a computer to perform specified functions or operations," can be conceptualized in (at least) two ways. One can speak of software in the abstract: the instructions themselves detached from any medium. (An analogy: The notes of Beethoven's Ninth Symphony.) One can alternatively envision a tangible "copy" of software, the instructions encoded on a medium such as a CD-ROM. (Sheet music for Beethoven's Ninth.) AT&T argues that software in the abstract, not simply a particular copy of software, qualifies as a "component" under § 271(f). Microsoft and the United States argue that only a copy of software, not software in the abstract, can be a component.

The significance of these diverse views becomes apparent when we turn to the second question: Were components of the foreign-made computers involved in this case "supplied" by Microsoft "from the United States"? If the relevant components are the copies of Windows actually installed on the foreign computers, AT&T could not persuasively argue that those components, though generated abroad, were "supplied from the United States" as § 271(f) requires for liability to attach.<sup>9</sup>



<sup>9</sup>On this view of “component,” the copies of Windows on the master disks and electronic transmissions that Microsoft sent from the United States could not themselves serve as a basis for liability, because those copies were not installed on the foreign manufacturers’ computers. See § 271(f)(1) (encompassing only those components “combined outside of the United States in a manner that would infringe the patent if such combination occurred within the United States”).

If, on the other hand, Windows in the abstract qualifies as a component within § 271(f)’s compass, it would not matter that the master copies of Windows software dispatched from the United States were not themselves installed abroad as working parts of the foreign computers.<sup>10</sup>

<sup>10</sup> The Federal Circuit panel in this case, relying on that court’s prior decision in *Eolas Technologies Inc. v. Microsoft Corp.*, 399 F.3d 1325 (Fed. Cir. 2005), held that software qualifies as a component under § 271(f). We are unable to determine, however, whether the Federal Circuit panels regarded as a component software in the abstract, or a copy of software.

With this explanation of the relationship between the two questions in view, we further consider the twin inquiries.

## B

First, when, or in what form, does software become a “component” under § 271(f)? We construe § 271(f)’s terms “in accordance with their ordinary or natural meaning.” Section 271(f) applies to the supply abroad of the “components of a patented invention, where *such components* are uncombined in whole or in part, in such manner as to actively induce the combination of *such components*.” § 271(f)(1). The provision thus applies only to “such components”<sup>11</sup> as are combined to form the “patented invention” at issue.

<sup>11</sup> “Component” is commonly defined as “a constituent part,” “element,” or “ingredient.” WEBSTER’S THIRD NEW INTERNATIONAL DICTIONARY OF THE ENGLISH LANGUAGE 466 (1981).

The patented invention here is AT&T’s speech-processing computer.

Until it is expressed as a computer-readable “copy,” *e.g.*, on a CD-ROM, Windows software—indeed any software detached from an activating medium—remains uncombinable. It cannot be inserted into a CD-ROM drive or downloaded from the Internet; it cannot be installed or executed on a computer. Abstract software code is an idea without physical embodiment, and as such, it does not match § 271(f)’s categorization: “components” amenable to “combination.” Windows abstracted from a tangible copy no doubt is information—a detailed set of instructions—and thus might be compared to a blueprint (or anything containing design information, *e.g.*, a schematic,

template, or prototype). A blueprint may contain precise instructions for the construction and combination of the components of a patented device, but it is not itself a combinable component of that device. AT&T and its *amici* do not suggest otherwise.

AT&T urges that software, at least when expressed as machine-readable object code, is distinguishable from design information presented in a blueprint. Software, unlike a blueprint, is “modular”; it is a stand-alone product developed and marketed “for use on many different types of computer hardware and in conjunction with many other types of software.” Software’s modularity persists even after installation; it can be updated or removed (deleted) without affecting the hardware on which it is installed. Software, unlike a blueprint, is also “dynamic.” After a device has been built according to a blueprint’s instructions, the blueprint’s work is done (as AT&T puts it, the blueprint’s instructions have been “exhausted”). Software’s instructions, in contrast, are contained in and continuously performed by a computer.

The distinctions advanced by AT&T do not persuade us to characterize software, uncoupled from a medium, as a combinable component. Blueprints too, or any design information for that matter, can be independently developed, bought, and sold. If the point of AT&T’s argument is that we do not see blueprints lining stores’ shelves, the same observation may be made about software in the abstract: What retailers sell, and consumers buy, are *copies* of software. Likewise, before software can be contained in and continuously performed by a computer, before it can be updated or deleted, an actual, physical copy of the software must be delivered by CD-ROM or some other means capable of interfacing with the computer.

Because it is so easy to encode software’s instructions onto a medium that can be read by a computer, AT&T intimates, that extra step should not play a decisive role under § 271(f). But the extra step is what renders the software a usable, combinable part of a computer; easy or not, the copy-producing step is essential. Moreover, many tools may be used easily and inexpensively to generate the parts of a device. A machine for making sprockets might be used by a manufacturer to produce tens of thousands of sprockets an hour. That does not make the machine a “component” of the tens of thousands of devices in which the sprockets are incorporated, at least not under any ordinary understanding of the term “component.” Congress, of course, might have included within § 271(f)’s compass, for example, not only combinable “components” of a patented invention, but also “information, instructions, or tools from which those components readily may be generated.” It did not. In sum, a copy of Windows, not Windows in the abstract, qualifies as a “component” under § 271(f).

## C

The next question, has Microsoft “supplied from the United States” components of the computers here involved? Under a conventional reading of § 271(f)’s text, the answer would be “No,” for the foreign-made copies of Windows actually installed on the computers were “supplied” from places outside the United States. The Federal Circuit majority concluded, however, that “for software ‘components,’ the act of copying is subsumed in the act of ‘supplying.’” A master sent abroad, the majority observed, differs not at all from the exact copies, easily, inexpensively, and swiftly generated from the master; hence “sending a single copy abroad with the intent that it be replicated invokes § 271(f) liability for the foreign-made copies.”

Judge Rader, dissenting, noted that “supplying” is ordinarily understood to mean an activity separate and distinct from any subsequent “copying, replicating, or reproducing—in effect manufacturing.” He further observed: “The only true difference between making and supplying software components and physical components of other patented inventions is that copies of software components are easier to make and transport.” But nothing in § 271(f)’s text, Judge Rader maintained, renders ease of copying a relevant, no less decisive, factor in triggering liability for infringement. We agree.

Section 271(f) prohibits the supply of components “from the United States in such manner as to actively induce the combination of *such components*.” § 271(f)(1). Under this formulation, the very components supplied from the United States, and not copies thereof, trigger § 271(f) liability when combined abroad to form the patented invention at issue. Here, as we have repeatedly noted, the copies of Windows actually installed on the foreign computers were not themselves supplied from the United States. Indeed, those copies did not exist until they were generated by third parties outside the United States. Copying software abroad, all might agree, is indeed easy and inexpensive. But the same could be said of other items: “Keys or machine parts might be copied from a master; chemical or biological substances might be created by reproduction; and paper products might be made by electronic copying and printing.” Brief for United States as *Amicus Curiae* 24. Section 271(f) contains no instruction to gauge when duplication is easy and cheap enough to deem a copy in fact made abroad nevertheless “supplied from the United States.” The absence of anything addressing copying in the statutory text weighs against a judicial determination that replication abroad of a master dispatched from the United States “supplies” the foreign-made copies from the United States within the intentment of § 271(f).

## D

Any doubt that Microsoft’s conduct falls outside § 271(f)’s compass would be resolved by the presumption against extraterritoriality, on which we have already touched. The

presumption that United States law governs domestically but does not rule the world applies with particular force in patent law. The traditional understanding that our patent law “operate[s] only domestically and does not extend to foreign activities,” is embedded in the Patent Act itself, which provides that a patent confers exclusive rights in an invention within the United States. 35 U.S.C. § 154(a)(1) (patentee’s rights over invention apply to manufacture, use, or sale “throughout the United States” and to importation “into the United States”). See *Deepsouth*, 406 U.S. at 531 (“Our patent system makes no claim to extraterritorial effect”; our legislation “does not, and was not intended to, operate beyond the limits of the United States, and we correspondingly reject the claims of others to such control over our markets.”).

As a principle of general application, moreover, we have stated that courts should “assume that legislators take account of the legitimate sovereign interests of other nations when they write American laws.” Thus, as the United States accurately conveyed in this case: “Foreign conduct is generally the domain of foreign law,” and in the area here involved, in particular, foreign law “may embody different policy judgments about the relative rights of inventors, competitors, and the public in patented inventions.” Brief for United States as *Amicus Curiae* 28. Applied to this case, the presumption tugs strongly against construction of § 271(f) to encompass as a “component” not only a physical copy of software, but also software’s intangible code, and to render “supplied from the United States” not only exported copies of software, but also duplicates made abroad.

AT&T argues that the presumption is inapplicable because Congress enacted § 271(f) specifically to extend the reach of United States patent law to cover certain activity abroad. But as this Court has explained, “the presumption is not defeated just because a statute specifically addresses an issue of extraterritorial application,” *Smith v. United States*, 507 U.S. 197, 204 (1993); it remains instructive in determining the *extent* of the statutory exception.

AT&T alternately contends that the presumption holds no sway here given that § 271(f), by its terms, applies only to domestic conduct, *i.e.*, to the supply of a patented invention’s components “from the United States.” § 271(f)(1). AT&T’s reading, however, “converts a single act of supply from the United States into a springboard for liability each time a copy of the software is subsequently made abroad and combined with computer hardware abroad for sale abroad.” Brief for United States as *Amicus Curiae* 29. In short, foreign law alone, not United States law, currently governs the manufacture and sale of components of patented inventions in foreign countries. If AT&T desires to prevent copying in foreign countries, its remedy today lies in obtaining and enforcing foreign patents.

## IV

AT&T urges that reading § 271(f) to cover only those copies of software actually dispatched from the United States creates a “loophole” for software makers. Liability for infringing a United States patent could be avoided, as Microsoft’s practice shows, by an easily arranged circumvention: Instead of making installation copies of software in the United States, the copies can be made abroad, swiftly and at small cost, by generating them from a master supplied from the United States. The Federal Circuit majority found AT&T’s plea compelling:

Were we to hold that Microsoft’s supply by exportation of the master versions of the Windows software—specifically for the purpose of foreign replication—avoids infringement, we would be subverting the remedial nature of § 271(f), permitting a technical avoidance of the statute by ignoring the advances in a field of technology—and its associated industry practices—that developed after the enactment of § 271(f). Section 271(f), if it is to remain effective, must therefore be interpreted in a manner that is appropriate to the nature of the technology at issue.

While the [Federal Circuit] majority’s concern is understandable, we are not persuaded that dynamic judicial interpretation of § 271(f) is in order. The “loophole,” in our judgment, is properly left for Congress to consider, and to close if it finds such action warranted.

There is no dispute, we note again, that § 271(f) is inapplicable to the export of design tools—blueprints, schematics, templates, and prototypes—all of which may provide the information required to construct and combine overseas the components of inventions patented under United States law. We have no license to attribute to Congress an unstated intention to place the information Microsoft dispatched from the United States in a separate category.

Section 271(f) was a direct response to a gap in our patent law revealed by this Court’s *Deepsouth* decision. The facts of that case were undeniably at the fore when § 271(f) was in the congressional hopper. In *Deepsouth*, the items exported were kits containing all the physical, readily assemblable parts of a shrimp deveining machine (not an intangible set of instructions), and those parts themselves (not foreign-made copies of them) would be combined abroad by foreign buyers. Having attended to the gap made evident in *Deepsouth*, Congress did not address other arguable gaps: Section 271(f) does not identify as an infringing act conduct in the United States that facilitates making a component of a patented invention outside the United States; nor does the provision check “supplying from the United States” information, instructions, or other materials needed to make copies abroad. Given that Congress did not home in on the loophole AT&T describes, and in view of the expanded extraterritorial thrust AT&T’s reading of § 271(f) entails, our

precedent leads us to leave in Congress' court the patent-protective determination AT&T seeks.

Congress is doubtless aware of the ease with which software (and other electronic media) can be copied, and has not left the matter untouched. In 1998, Congress addressed "the ease with which pirates could copy and distribute a copyrightable work in digital form." The resulting measure, the Digital Millennium Copyright Act, 17 U.S.C. § 1201 *et seq.*, "backed with legal sanctions the efforts of copyright owners to protect their works from piracy behind digital walls such as encryption codes or password protections." *Universal City Studios*, 273 F.3d at 435. If the patent law is to be adjusted better "to account for the realities of software distribution," the alteration should be made after focused legislative consideration, and not by the Judiciary forecasting Congress' likely disposition.

### Context & Application

1. In *Life Technologies v. Promega*, the Court again interpreted § 271(f) narrowly. See 139 S.Ct. 156 (2018). The patent at issue in that case covered a five-component kit used for analysis of a DNA sample. Life Technologies manufactured the second of these components (Taq polymerase) in the United States and shipped it to the United Kingdom where it was incorporated in genetic testing kits sold worldwide. The Supreme Court reversed the Federal Circuit's ruling that the manufacture and export of a single component may be the basis for a finding of infringement under the statute. Instead, the Court held "that a single component does not constitute a substantial portion of the components that can give rise to liability under § 271(f)(1)." In its determination of the meaning of "substantial portion of the components," the Court distinguished the first and second paragraphs of the section, noting that the second paragraph addresses the export of a single component but limits liability to situations where the component is not a commodity. The first paragraph—at issue in the case—refers to "a substantial portion of the components of a patented invention." The Court declined to find that this required a qualitative determination of how important a single component was to the invention, instead finding that the context of the provision showed that it referred to the export of multiple components, and that a single component could not satisfy the statutory provision.

The Court was cognizant of the importance of notice to third parties of the limits of liability, asking how, under Promega's suggested test for the importance of components, "market participants attempting to avoid liability . . . [are] to determine the relative importance of the components of an invention?" In contrast to *Microsoft*, the Court in *Life Technologies* did not focus on extraterritoriality as a limiting factor. Instead, the Court looked to the history and purpose of the statutory language and what type of acts the

## INFRINGEMENT

statute seeks to capture. In tandem, it appears that the two paragraphs of the section expand liability to reach acts that are close to infringement “makings” that would be direct infringement, but that don’t fully meet the patent claims, with the first paragraph reaching the *Deepsouth* situation of manufacturing all (or a substantial portion) of the components in the United States for foreign assembly and the second paragraph reaching situations where a single component may so fully embody the invention that it only requires the addition of fairly insignificant other components abroad.





## 10. DEFENSES

The most common defenses to claims of patent infringement are invalidity and noninfringement. But they are not the only defenses. This chapter will cover some other important defenses, specifically inequitable conduct, laches, the reverse doctrine of equivalents, experimental use, prior user rights, and exhaustion.

### A. Inequitable Conduct

*Therasense, Inc. v. Becton, Dickinson and Co.*  
649 F.3d 1276 (Fed. Cir. 2011)

RADER, Chief Judge.

The United States District Court for the Northern District of California found U.S. Patent No. 5,820,551 (“the ‘551 patent”) unenforceable due to inequitable conduct. Therasense, Inc. (now Abbott Diabetes Care, Inc.) and Abbott Laboratories (collectively, “Abbott”) appeal that judgment. This court vacates and remands for further proceedings consistent with this opinion.

#### I

The ‘551 patent involves disposable blood glucose test strips for diabetes management. These strips employ electrochemical sensors to measure the level of glucose in a sample of blood. When blood contacts a test strip, glucose in the blood reacts with an enzyme on the strip, resulting in the transfer of electrons from the glucose to the enzyme. A mediator transfers these electrons to an electrode on the strip. Then, the electrons flow from the strip to a glucose meter, which calculates the glucose concentration based on the electrical current.

...

[The ‘551 patent claims include the following element:]

a reference counterelectrode in electrical contact with said second conductor and positioned to contact said whole blood sample,

*wherein said active electrode is configured to be exposed to said whole blood sample without an intervening membrane or other whole blood filtering member*

'551 patent col. 13 l.29–col. 14 l.3 “Whole blood,” an important term in the claim, means blood that contains all of its components, including red blood cells.

In the prior art, some sensors employed diffusion-limiting membranes to control the flow of glucose to the electrode because the slower mediators of the time could not deal with a rapid influx of glucose. Other prior art sensors used protective membranes to prevent “fouling.” Fouling occurs when red blood cells stick to the active electrode and interfere with electron transfer to the electrode. Protective membranes permit glucose molecules to pass, but not red blood cells.

Abbott filed the original application leading to the '551 patent in 1984. Over thirteen years, that original application saw multiple rejections for anticipation and obviousness, including repeated rejections over U.S. Patent No. 4,545,382 (“the '382 patent”), another patent owned by Abbott. The '382 patent specification discussed protective membranes in the following terms: “Optionally, but preferably when being used on live blood, a protective membrane surrounds both the enzyme and the mediator layers, permeable to water and glucose molecules.” “Live blood” refers to blood within a body.

In 1997, Lawrence Pope, Abbott’s patent attorney, and Dr. Gordon Sanghera, Abbott’s Director of Research and Development, studied the novel features of their application and decided to present a new reason for a patent. Pope presented new claims to the examiner based on a new sensor that did not require a protective membrane for whole blood. Pope asserted that this distinction would overcome the prior art '382 patent, whose electrodes allegedly required a protective membrane. The examiner requested an affidavit to show that the prior art required a membrane for whole blood at the time of the invention.

To meet this evidentiary request, Dr. Sanghera submitted a declaration to the U.S. Patent and Trademark Office (“PTO”) stating:

One skilled in the art would have felt that an active electrode comprising an enzyme and a mediator would require a protective membrane if it were to be used with a whole blood sample. One skilled in the art would not read lines 63 to 65 of column 4 of U.S. Patent No. 4,545,382 to teach that the use of a protective membrane with a whole blood sample is optionally or merely preferred.

Pope, in submitting Sanghera’s affidavit represented that: “. . . One skilled in the art would not have read the disclosure of the '382 patent as teaching that the use of a protective membrane with whole blood samples was optional. . . .”

Several years earlier, while prosecuting the European counterpart to the '382 patent, European Patent EP 0 078 636 (“EP '636”), Abbott made representations to the European Patent Office (“EPO”) regarding the same “optionally, but preferably” language in the European specification. On January 12, 1994, to distinguish a German reference labeled

## DEFENSES

D1, which required a diffusion-limiting membrane, Abbott's European patent counsel argued that their invention did not require a diffusion-limiting membrane . . . .

...

On May 23, 1995, Abbott's European patent counsel submitted another explanation about the D1 reference and EP '636. [Regarding the "optionally, but preferably" language, the European patent counsel stated:] "It is submitted that this disclosure is unequivocally clear. The protective membrane is optional, however, it is preferred when used on live blood in order to prevent the larger constituents of the blood, in particular erythrocytes from interfering with the electrode sensor. . . ."

### II

[A number of cases between these parties and related to the '164, '745, and '551 patents were consolidated in the Northern District of California.] Of primary relevance here, the district court held the '551 patent unenforceable for inequitable conduct because Abbott did not disclose to the PTO its briefs to the EPO . . . . [The panel upheld the district court's judgments of noninfringement, invalidity, and unenforceability. The Federal Circuit then took the case *en banc*.]

### III

Inequitable conduct is an equitable defense to patent infringement that, if proved, bars enforcement of a patent. This judge-made doctrine evolved from a trio of Supreme Court cases that applied the doctrine of unclean hands to dismiss patent cases involving egregious misconduct: *Keystone Driller Co. v. General Excavator Co.*, 290 U.S. 240 (1933), *Hazel-Atlas Glass Co. v. Hartford-Empire Co.*, 322 U.S. 238 (1944), and *Precision Instrument Manufacturing Co. v. Automotive Maintenance Machinery Co.*, 324 U.S. 806 (1945).

*Keystone* involved the manufacture and suppression of evidence. The patentee knew of "a possible prior use" by a third party prior to filing a patent application but did not inform the PTO. After the issuance of the patent, the patentee paid the prior user to sign a false affidavit stating that his use was an abandoned experiment and bought his agreement to keep secret the details of the prior use and to suppress evidence. With these preparations in place, the patentee then asserted this patent, along with two other patents, against Byers Machine Co. ("Byers"). Unaware of the prior use and of the cover-up, the court held the patents valid and infringed and granted an injunction.

The patentee then asserted the same patents against General Excavator Co. and Osgood Co. and sought a temporary injunction based on the decree in the previous Byers case. The district court denied the injunctions but made the defendants post bonds. The defendants discovered and introduced evidence of the corrupt transaction between the patentee and the prior user. The district court declined to dismiss these cases for unclean

hands. On appeal, the Sixth Circuit reversed and remanded with instructions to dismiss the complaints. The Supreme Court affirmed.

The Supreme Court explained that if the corrupt transaction between the patentee and the prior user had been discovered in the previous Byers case, “the court undoubtedly would have been warranted in holding it sufficient to require dismissal of the cause of action.” Because the patentee used the Byers decree to seek an injunction in the cases against General Excavator Co. and Osgood Co., it did not come to the court with clean hands, and dismissal of these cases was appropriate.

Like *Keystone*, *Hazel–Atlas* involved both the manufacture and suppression of evidence. Faced with “apparently insurmountable Patent Office opposition,” the patentee’s attorneys wrote an article describing the invention as a remarkable advance in the art and had William Clarke, a well-known expert, sign it as his own and publish it in a trade journal. After the patentee submitted the Clarke article to the PTO in support of its application, the PTO allowed a patent to issue.

The patentee brought suit against Hazel–Atlas Glass Co., alleging infringement of this patent. The district court found no infringement. On appeal, the patentee’s attorneys emphasized the Clarke article, and the Third Circuit reversed the district court’s judgment, holding the patent valid and infringed. The patentee then went to great lengths to conceal the false authorship of the Clarke article, contacting Clarke multiple times, including before and after Hazel–Atlas’s investigators spoke to him. After Hazel–Atlas settled with the patentee, the patentee paid Clarke a total of \$8,000. These facts surfaced in a later suit.

On the basis of these newly-discovered facts, Hazel–Atlas petitioned the Third Circuit to vacate its judgment, but the court refused. The Supreme Court reversed. The Supreme Court explained that if the district court had learned of the patentee’s deception before the PTO, it would have been warranted in dismissing the patentee’s case under the doctrine of unclean hands. Likewise, had the Third Circuit learned of the patentee’s suppression of evidence, it also could have dismissed the appeal. Accordingly, the Supreme Court vacated the judgment against Hazel–Atlas and reinstated the original judgment dismissing the patentee’s case.

In *Precision*, the patentee suppressed evidence of perjury before the PTO and attempted to enforce the perjury-tainted patent. The PTO had declared an interference between two patent applications, one filed by Larson and the other by Zimmerman. Automotive Maintenance Machinery Co. (“Automotive”) owned the Zimmerman application. Larson filed his preliminary statement in the PTO proceedings with false dates of conception, disclosure, drawing, description, and reduction to practice. Later, he testified in support of these false dates in an interference proceeding.

## DEFENSES

Automotive discovered this perjury but did not reveal this information to the PTO. Instead, Automotive entered into a private settlement with Larson that gave Automotive the rights to the Larson application and suppressed evidence of Larson's perjury. Automotive eventually received patents on both the Larson and Zimmerman applications. Despite knowing that the Larson patent was tainted with perjury, Automotive sought to enforce it against others.

The district court found that Automotive had unclean hands and dismissed the suit. The Seventh Circuit reversed. The Supreme Court reversed the Seventh Circuit's decision, explaining that dismissal was warranted because not only had the patentee failed to disclose its knowledge of perjury to the PTO, it had actively suppressed evidence of the perjury and magnified its effects.

### IV

The unclean hands cases of *Keystone*, *Hazel-Atlas*, and *Precision* formed the basis for a new doctrine of inequitable conduct that developed and evolved over time. Each of these unclean hands cases before the Supreme Court dealt with particularly egregious misconduct, including perjury, the manufacture of false evidence, and the suppression of evidence. Moreover, they all involved "deliberately planned and carefully executed schemes to defraud" not only the PTO but also the courts. As the inequitable conduct doctrine evolved from these unclean hands cases, it came to embrace a broader scope of misconduct, including not only egregious affirmative acts of misconduct intended to deceive both the PTO and the courts but also the mere nondisclosure of information to the PTO. Inequitable conduct also diverged from the doctrine of unclean hands by adopting a different and more potent remedy—unenforceability of the entire patent rather than mere dismissal of the instant suit.

In line with this wider scope and stronger remedy, inequitable conduct came to require a finding of both intent to deceive and materiality. To prevail on the defense of inequitable conduct, the accused infringer must prove that the applicant misrepresented or omitted material information with the specific intent to deceive the PTO. The accused infringer must prove both elements—intent and materiality—by clear and convincing evidence. If the accused infringer meets its burden, then the district court must weigh the equities to determine whether the applicant's conduct before the PTO warrants rendering the entire patent unenforceable.

This court recognizes that the early unclean hands cases do not present any standard for materiality. Needless to say, this court's development of a materiality requirement for inequitable conduct does not (and cannot) supplant Supreme Court precedent. Though inequitable conduct developed from these cases, the unclean hands doctrine remains

available to supply a remedy for egregious misconduct like that in the Supreme Court cases.

As inequitable conduct emerged from unclean hands, the standards for intent to deceive and materiality have fluctuated over time. In the past, this court has espoused low standards for meeting the intent requirement, finding it satisfied based on gross negligence or even negligence. Further weakening the showing needed to establish inequitable conduct, this court then placed intent and materiality together on a “sliding scale.” This modification to the inequitable conduct doctrine held patents unenforceable based on a reduced showing of intent if the record contained a strong showing of materiality, and vice versa. In effect, this change conflated, and diluted, the standards for both intent and materiality.

This court embraced these reduced standards for intent and materiality to foster full disclosure to the PTO. This new focus on encouraging disclosure has had numerous unforeseen and unintended consequences. Most prominently, inequitable conduct has become a significant litigation strategy. A charge of inequitable conduct conveniently expands discovery into corporate practices before patent filing and disqualifies the prosecuting attorney from the patentee's litigation team. Moreover, inequitable conduct charges cast a dark cloud over the patent's validity and paint the patentee as a bad actor. Because the doctrine focuses on the moral turpitude of the patentee with ruinous consequences for the reputation of his patent attorney, it discourages settlement and deflects attention from the merits of validity and infringement issues. . . .

Perhaps most importantly, the remedy for inequitable conduct is the “atomic bomb” of patent law. Unlike validity defenses, which are claim specific, see 35 U.S.C. § 288, inequitable conduct regarding any single claim renders the entire patent unenforceable. Unlike other deficiencies, inequitable conduct cannot be cured by reissue or reexamination. Moreover, the taint of a finding of inequitable conduct can spread from a single patent to render unenforceable other related patents and applications in the same technology family. Thus, a finding of inequitable conduct may endanger a substantial portion of a company's patent portfolio.

. . .

Left unfettered, the inequitable conduct doctrine has plagued not only the courts but also the entire patent system. Because allegations of inequitable conduct are routinely brought on “the slenderest grounds,” patent prosecutors constantly confront the specter of inequitable conduct charges. With inequitable conduct casting the shadow of a hangman's noose, it is unsurprising that patent prosecutors regularly bury PTO examiners with a deluge of prior art references, most of which have marginal value. . . .

## DEFENSES

While honesty at the PTO is essential, low standards for intent and materiality have inadvertently led to many unintended consequences, among them, increased adjudication cost and complexity, reduced likelihood of settlement, burdened courts, strained PTO resources, increased PTO backlog, and impaired patent quality. This court now tightens the standards for finding both intent and materiality in order to redirect a doctrine that has been overused to the detriment of the public.

### V

To prevail on a claim of inequitable conduct, the accused infringer must prove that the patentee acted with the specific intent to deceive the PTO. A finding that the misrepresentation or omission amounts to gross negligence or negligence under a “should have known” standard does not satisfy this intent requirement. “In a case involving nondisclosure of information, clear and convincing evidence must show that the applicant made a deliberate decision to withhold a known material reference.” In other words, the accused infringer must prove by clear and convincing evidence that the applicant knew of the reference, knew that it was material, and made a deliberate decision to withhold it.

...

Intent and materiality are separate requirements. A district court should not use a “sliding scale,” where a weak showing of intent may be found sufficient based on a strong showing of materiality, and vice versa. Moreover, a district court may not infer intent solely from materiality. Instead, a court must weigh the evidence of intent to deceive independent of its analysis of materiality. Proving that the applicant knew of a reference, should have known of its materiality, and decided not to submit it to the PTO does not prove specific intent to deceive.

Because direct evidence of deceptive intent is rare, a district court may infer intent from indirect and circumstantial evidence. However, to meet the clear and convincing evidence standard, the specific intent to deceive must be “the single most reasonable inference able to be drawn from the evidence.” Indeed, the evidence “must be sufficient to require a finding of deceitful intent in the light of all the circumstances.” Hence, when there are multiple reasonable inferences that may be drawn, intent to deceive cannot be found. This court reviews the district court’s factual findings regarding what reasonable inferences may be drawn from the evidence for clear error.

Because the party alleging inequitable conduct bears the burden of proof, the “patentee need not offer any good faith explanation unless the accused infringer first proves a threshold level of intent to deceive by clear and convincing evidence.” The absence of a good faith explanation for withholding a material reference does not, by itself, prove intent to deceive.

## VI

In the past, this court has tried to address the proliferation of inequitable conduct charges by raising the intent standard alone. In *Kingsdown*, this court made clear that gross negligence alone was not enough to justify an inference of intent to deceive. 863 F.2d at 876. *Kingsdown* established that “the involved conduct . . . must indicate sufficient culpability to require a finding of intent to deceive.” This higher intent standard, standing alone, did not reduce the number of inequitable conduct cases before the courts and did not cure the problem of overdisclosure of marginally relevant prior art to the PTO. To address these concerns, this court adjusts as well the standard for materiality.

...

This court holds that, as a general matter, the materiality required to establish inequitable conduct is but-for materiality. When an applicant fails to disclose prior art to the PTO, that prior art is but-for material if the PTO would not have allowed a claim had it been aware of the undisclosed prior art. Hence, in assessing the materiality of a withheld reference, the court must determine whether the PTO would have allowed the claim if it had been aware of the undisclosed reference. In making this patentability determination, the court should apply the preponderance of the evidence standard and give claims their broadest reasonable construction. Often the patentability of a claim will be congruent with the validity determination—if a claim is properly invalidated in district court based on the deliberately withheld reference, then that reference is necessarily material because a finding of invalidity in a district court requires clear and convincing evidence, a higher evidentiary burden than that used in prosecution at the PTO. However, even if a district court does not invalidate a claim based on a deliberately withheld reference, the reference may be material if it would have blocked patent issuance under the PTO’s different evidentiary standards.

As an equitable doctrine, inequitable conduct hinges on basic fairness. “The remedy imposed by a court of equity should be commensurate with the violation.” Because inequitable conduct renders an entire patent (or even a patent family) unenforceable, as a general rule, this doctrine should only be applied in instances where the patentee’s misconduct resulted in the unfair benefit of receiving an unwarranted claim. After all, the patentee obtains no advantage from misconduct if the patent would have issued anyway. Moreover, enforcement of an otherwise valid patent does not injure the public merely because of misconduct, lurking somewhere in patent prosecution, that was immaterial to the patent’s issuance.

Although but-for materiality generally must be proved to satisfy the materiality prong of inequitable conduct, this court recognizes an exception in cases of affirmative egregious misconduct. This exception to the general rule requiring but-for proof incorporates



## DEFENSES

elements of the early unclean hands cases before the Supreme Court, which dealt with “deliberately planned and carefully executed schemes” to defraud the PTO and the courts. *Hazel–Atlas*, 322 U.S. at 245. When the patentee has engaged in affirmative acts of egregious misconduct, such as the filing of an unmistakably false affidavit, the misconduct is material. After all, a patentee is unlikely to go to great lengths to deceive the PTO with a falsehood unless it believes that the falsehood will affect issuance of the patent. Because neither mere nondisclosure of prior art references to the PTO nor failure to mention prior art references in an affidavit constitutes affirmative egregious misconduct, claims of inequitable conduct that are based on such omissions require proof of but-for materiality. By creating an exception to punish affirmative egregious acts without penalizing the failure to disclose information that would not have changed the issuance decision, this court strikes a necessary balance between encouraging honesty before the PTO and preventing unfounded accusations of inequitable conduct.

### VII

In this case, the district court held the ’551 patent unenforceable for inequitable conduct because Abbott did not disclose briefs it submitted to the EPO regarding the European counterpart of the ’382 patent. . . . On remand, the district court should determine whether the PTO would not have granted the patent but for Abbott’s failure to disclose the EPO briefs. In particular, the district court must determine whether the PTO would have found Sanghera’s declaration and Pope’s accompanying submission unpersuasive in overcoming the obviousness rejection over the ’382 patent if Abbott had disclosed the EPO briefs.

. . . On remand, the district court should [also] determine whether there is clear and convincing evidence demonstrating that Sanghera or Pope knew of the EPO briefs, knew of their materiality, and made the conscious decision not to disclose them in order to deceive the PTO.

For the foregoing reasons, this court vacates the district court’s finding of inequitable conduct and remands for further proceedings consistent with this opinion.

### Context & Application

1. According to the Federal Circuit, what was wrong with the law of inequitable conduct prior to *Therasense*? What did the Federal Circuit change?

2. Following *Therasense*, courts are less likely to make a finding of inequitable conduct and parties are less likely to allege inequitable conduct. But it has not disappeared entirely. In 2017, for example, the Federal Circuit upheld a district court holding of inequitable conduct that found both but-for materiality and specific intent to deceive the

PTO. *Regeneron Pharms., Inc. v. Merus N.V.*, 864 F.3d 1343 (Fed. Cir. 2017). While the district court made evidentiary findings on but-for materiality (which the Federal Circuit found to be supported by substantial evidence), the finding of specific intent was based on adverse inferences the district court drew due to litigation misconduct. Because Regeneron’s conduct in failing to produce relevant documents warranted “serious sanctions,” and because reopening discovery would be unfair and costly to the litigants, the district court drew adverse inferences with respect to specific intent:

Regeneron failed to disclose documents directly related to its prosecuting attorneys’ mental impressions of the Withheld References during prosecution of the ’018 patent. The district court drew an adverse inference to sanction this litigation misconduct. The district court did not punish Regeneron’s litigation misconduct by holding the patent unenforceable. Only after Merus proved the remaining elements of inequitable conduct did the district court hold the patent unenforceable. In light of Appellant’s widespread litigation misconduct . . . we conclude that the district court did not abuse its discretion by drawing an adverse inference of specific intent to deceive the PTO.

864 F.3d at 1364.

## B. Laches

There are two types of laches that are relevant to patents. The first is for when a plaintiff delays in filing suit. The second is when a patent holder delays in prosecuting a patent. Under the previous patent term rules, which ran for seventeen years from issuance, there was an opportunity for strategic delay of applications. Applicants could file early and then delay prosecution, including through the continuations, while watching which technologies the industry adopted. Once the industry locked into a technology that fell within the scope of the (then-secret) application, the applicant could resume prosecution; when the patent issued, industry participants would have a hard time avoiding infringement, and the patentee would have significant leverage in licensing negotiations. This second type of laches has become much less important because utility patent terms now begin on the date of filing rather than the date of issuance. The first type of laches—delay in bringing suit—came to the attention of the Supreme Court recently.

*SCA Hygiene Products Aktiebolag v. First Quality Baby Products, LLC*  
137 S. Ct. 954 (2017)

Justice ALITO delivered the opinion of the Court.

We return to a subject that we addressed in *Petrella v. Metro–Goldwyn–Mayer, Inc.*, 134 S.Ct. 1962 (2014): the relationship between the equitable defense of laches and claims for damages that are brought within the time allowed by a statute of limitations. In *Petrella*, we held that laches cannot preclude a claim for damages incurred within the Copyright Act’s 3-year limitations period. “Laches,” we explained, “cannot be invoked to bar legal relief” “in the face of a statute of limitations enacted by Congress.” The question in this case is whether *Petrella*’s reasoning applies to a similar provision of the Patent Act, 35 U.S.C. § 286. We hold that it does.

I

Petitioners SCA Hygiene Products Aktiebolag and SCA Personal Care, Inc. (collectively, SCA), manufacture and sell adult incontinence products. In October 2003, SCA sent a letter to respondents (collectively, First Quality), alleging that First Quality was making and selling products that infringed SCA’s rights under U.S. Patent No. 6,375,646 B1 (‘646 patent). First Quality responded that one of *its* patents—U.S. Patent No. 5,415,649 (Watanabe patent)—antedated the ‘646 patent and revealed “the same diaper construction.” As a result, First Quality maintained, the ‘646 patent was invalid and could not support an infringement claim. SCA sent First Quality no further correspondence regarding the ‘646 patent, and First Quality proceeded to develop and market its products.

In July 2004, without notifying First Quality, SCA asked the Patent and Trademark Office (PTO) to initiate a reexamination proceeding to determine whether the ‘646 patent was valid in light of the Watanabe patent. Three years later, in March 2007, the PTO issued a certificate confirming the validity of the ‘646 patent.

In August 2010, SCA filed this patent infringement action against First Quality. First Quality moved for summary judgment based on laches and equitable estoppel, and the District Court granted that motion on both grounds.

SCA appealed to the Federal Circuit, but before the Federal Circuit panel issued its decision, this Court decided *Petrella*. The panel nevertheless held, based on a Federal Circuit precedent, *A.C. Aukerman Co. v. R.L. Chaides Constr. Co.*, 960 F.2d 1020 (1992) (*en banc*), that SCA’s claims were barred by laches.

The Federal Circuit then reheard the case *en banc* in order to reconsider *Aukerman* in light of *Petrella*. But in a 6–to–5 decision, the *en banc* court reaffirmed *Aukerman*’s holding that laches can be asserted to defeat a claim for damages incurred within the 6–year period

set out in the Patent Act. As it had in *Aukerman*, the *en banc* court concluded that Congress, in enacting the Patent Act, had “codified a laches defense” that “barred recovery of legal remedies.” Judge Hughes, joined by four other judges, dissented. We granted certiorari.

## II

Laches is “a defense developed by courts of equity” to protect defendants against “unreasonable, prejudicial delay in commencing suit.” *Petrella*. See also 1 D. DOBBS, LAW OF REMEDIES § 2.3(5), p. 89 (2d ed. 1993) (Dobbs) (“The equitable doctrine of laches bars the plaintiff whose unreasonable delay in prosecuting a claim or protecting a right has worked a prejudice to the defendant”). Before the separate systems of law and equity were merged in 1938, the ordinary rule was that laches was available only in equity courts. This case turns on the application of the defense to a claim for damages, a quintessential legal remedy. We discussed this subject at length in *Petrella*.

*Petrella* arose out of a copyright dispute relating to the film *Raging Bull*. The Copyright Act’s statute of limitations requires a copyright holder claiming infringement to file suit “within three years after the claim accrued.” 17 U.S.C. § 507(b). In *Petrella*, the plaintiff sought relief for alleged acts of infringement that accrued within that 3–year period, but the lower courts nevertheless held that laches barred her claims. We reversed, holding that laches cannot defeat a damages claim brought within the period prescribed by the Copyright Act’s statute of limitations. And in so holding, we spoke in broad terms.

*Petrella*’s holding rested on both separation-of-powers principles and the traditional role of laches in equity. Laches provides a shield against untimely claims, and statutes of limitations serve a similar function. When Congress enacts a statute of limitations, it speaks directly to the issue of timeliness and provides a rule for determining whether a claim is timely enough to permit relief. The enactment of a statute of limitations necessarily reflects a congressional decision that the timeliness of covered claims is better judged on the basis of a generally hard and fast rule rather than the sort of case-specific judicial determination that occurs when a laches defense is asserted. Therefore, applying laches within a limitations period specified by Congress would give judges a “legislation-overriding” role that is beyond the Judiciary’s power. As we stressed in *Petrella*, “courts are not at liberty to jettison Congress’ judgment on the timeliness of suit.”

Applying laches within the limitations period would also clash with the purpose for which the defense developed in the equity courts. As *Petrella* recounted, the “principal application” of laches “was, and remains, to claims of an equitable cast for which the Legislature has provided no fixed time limitation.” Laches is a gap-filling doctrine, and where there is a statute of limitations, there is no gap to fill.

With *Petrella*’s principles in mind, we turn to the present dispute.

## DEFENSES

### III

#### A

Although the relevant statutory provisions in *Petrella* and this case are worded differently, *Petrella's* reasoning easily fits the provision at issue here. As noted, the statute in *Petrella* precludes a civil action for copyright infringement “unless it is commenced within three years after the claim accrued.” 17 U.S.C. § 507(b). We saw in this language a congressional judgment that a claim filed within three years of accrual cannot be dismissed on timeliness grounds.

The same reasoning applies in this case. Section 286 of the Patent Act provides: “Except as otherwise provided by law, no recovery shall be had for any infringement committed more than six years prior to the filing of the complaint or counterclaim for infringement in the action.” By the logic of *Petrella*, we infer that this provision represents a judgment by Congress that a patentee may recover damages for any infringement committed within six years of the filing of the claim.

#### B

First Quality contends that this case differs from *Petrella* because § 286 of the Patent Act is not a true statute of limitations. A true statute of limitations, we are told, “runs forward from the date a cause of action accrues,” but § 286 “runs backward from the time of suit.”

*Petrella* cannot reasonably be distinguished on this ground. First Quality thinks it critical that § 286 “runs backward from the time of suit,” but *Petrella* described the Copyright Act’s statute of limitations in almost identical terms. We said that this provision “allows plaintiffs to gain retrospective relief running only three years back from the date the complaint was filed.” And we described the Copyright Act’s statute of limitations as “a three-year look-back limitations period.”

First Quality contends that the application of a true statute of limitations, like the defense of laches (but unlike § 286), takes into account the fairness of permitting the adjudication of a particular plaintiff’s claim. First Quality argues as follows: “When Congress enacts a true statute of limitations, it can be viewed as having made a considered judgment about how much delay may occur after a plaintiff knows of a cause of action (i.e., after accrual) before the plaintiff must bring suit—thus potentially leaving no room for judges to evaluate the reasonableness of a plaintiff’s delay on a case-by-case basis under laches.” According to First Quality, § 286 of the Patent Act is different because it “turns only on when the infringer is sued, regardless of when the patentee learned of the infringement.”

## CHAPTER 10

This argument misunderstands the way in which statutes of limitations generally work. First Quality says that the accrual of a claim, the event that triggers the running of a statute of limitations, occurs when “a plaintiff knows of a cause of action,” but that is not ordinarily true. As we wrote in *Petrella*, “a claim ordinarily accrues ‘when a plaintiff has a complete and present cause of action.’” While some claims are subject to a “discovery rule” under which the limitations period begins when the plaintiff discovers or should have discovered the injury giving rise to the claim, that is not a universal feature of statutes of limitations.

For these reasons, *Petrella* cannot be dismissed as applicable only to what First Quality regards as true statutes of limitations. At least for present purposes, nothing depends on this debatable taxonomy.

### C

The Federal Circuit based its decision on a different footing. Section 286 of the Patent Act begins with the phrase “except as otherwise provided by law,” and according to the Federal Circuit, § 282 of the Act is a provision that provides otherwise. In its view, § 282 creates an exception to § 286 by codifying laches as a defense to all patent infringement claims, including claims for damages suffered within § 286’s 6-year period. Section 282(b), which does not specifically mention laches, provides in relevant part as follows:

The following shall be defenses in any action involving the validity or infringement of a patent and shall be pleaded:

(1) Noninfringement, absence of liability for infringement or unenforceability.

The *en banc* majority below never identified which word or phrase in § 282 codifies laches as a defense, but First Quality argues that laches falls within § 282(b)(1) because laches is a defense based on “unenforceability.”

SCA disputes this interpretation of § 282(b)(1), arguing that laches does not make a patent categorically unenforceable. We need not decide this question. Even if we assume for the sake of argument that § 282(b)(1) incorporates a laches defense of *some dimension*, it does not necessarily follow that this defense may be invoked to bar a claim for damages incurred within the period set out in § 286. Indeed, it would be exceedingly unusual, if not unprecedented, if Congress chose to include in the Patent Act both a statute of limitations for damages and a laches provision applicable to a damages claim. Neither the Federal Circuit, nor First Quality, nor any of First Quality’s amici has identified a single federal statute that provides such dual protection against untimely claims.

### D

In holding that Congress codified a damages-limiting laches defense, the Federal Circuit relied on patent cases decided by the lower courts prior to the enactment of the

## DEFENSES

Patent Act. After surveying these cases, the Federal Circuit concluded that by 1952 there was a well-established practice of applying laches to such damages claims and that Congress, in adopting § 282, must have chosen to codify such a defense in § 282(b)(1). First Quality now presses a similar argument. We have closely examined the cases on which the Federal Circuit and First Quality rely, and we find that they are insufficient to support the suggested interpretation of the Patent Act. The most prominent feature of the relevant legal landscape at the time of enactment of the Patent Act was the well-established general rule, often repeated by this Court, that laches cannot be invoked to bar a claim for damages incurred within a limitations period specified by Congress. *Petrella* confirmed and restated this long-standing rule. If Congress examined the relevant legal landscape when it adopted 35 U.S.C. § 282, it could not have missed our cases endorsing this general rule.

The Federal Circuit and First Quality dismiss the significance of this Court's many reiterations of the general rule because they were not made in patent cases. But as the dissenters below noted, "patent law is governed by the same common-law principles, methods of statutory interpretation, and procedural rules as other areas of civil litigation." 807 F.3d, at 1333 (opinion of Hughes, J.).

In light of the general rule regarding the relationship between laches and statutes of limitations, nothing less than a broad and unambiguous consensus of lower court decisions could support the inference that § 282(b)(1) codifies a very different patent-law-specific rule. No such consensus is to be found.

...

First Quality and its supporting *amici* also make various policy arguments, but we cannot overrule Congress's judgment based on our own policy views. We note, however, as we did in *Petrella*, that the doctrine of equitable estoppel provides protection against some of the problems that First Quality highlights, namely, unscrupulous patentees inducing potential targets of infringement suits to invest in the production of arguably infringing products. Indeed, the Federal Circuit held that there are genuine disputes of material fact as to whether equitable estoppel bars First Quality's claims in this very case.

Laches cannot be interposed as a defense against damages where the infringement occurred within the period prescribed by § 286. The judgment of the Court of Appeals is vacated in part, and the case is remanded for further proceedings consistent with this opinion. It is so ordered.

### Context & Application

1. Is the opinion driven primarily by *Petrella* or by interpretation of Section 286? If *Petrella*, was that case more relevant because it dealt with another IP statute? Why? Or

was it simply because *Petrella* was the Court's most recent analysis of the relationship between laches and statutes of limitations?

2. Are there considerations specific to patents that change how the statute of limitations should be applied? Or, considerations specific to other forms of IP? Other kinds of intangible property?

3. Statutes of limitations form the foundation for the doctrine of adverse possession in real property law. Should there be a doctrine of adverse possession in patent law? Which of the justifications for real property adverse possession apply with equal force in patent law? Which ones don't apply?

### C. Reverse Doctrine of Equivalents

The reverse doctrine of equivalents addresses circumstances where an accused product meets all of the claim elements of a patent, but the accused device is so changed in principle from the patented invention that the court does not consider it to be infringing. In *Westinghouse v. Boyden Power-Brake Co.*, the Supreme Court famously explained and applied the reverse doctrine of equivalents in affirming the appellate court's reversal of the district court's findings that Boyden Power-Brake Co. had infringed one of the claims of Westinghouse's U.S. patent No. 360,070. 170 U.S. 537 (1898). The technology at issue was for air brakes for railway trains, an area of heavy innovation and patenting. The Court recognizes Westinghouse's substantial contribution to this technological development, citing an earlier district court case that upheld the validity of a prior Westinghouse patent:

The validity of this patent was sustained by the circuit court for the Northern district of Ohio in *Westinghouse v. Air-Brake Co.*, 9 O. G. 538, Fed. Cas. No. 17,450. The court said, in its opinion, that, while Westinghouse was not the first to conceive the idea of operating railway brakes by air pressure, such fact did not detract at all from his merits or rights as a successful inventor; that the new elements introduced by him 'fully substantiated his pretensions as an original and meritorious inventor, and entitled him, as such, to the amplest protection of the law'; and that it appeared from the record and briefs that he was the first to put an air brake into successful, actual use.

*Id.* at 546. The later patent at issue in *Westinghouse* was an attempt to address the problem that air brakes did not operate quickly enough to bring a long train to a stop, because "the air from the auxiliary reservoirs did not act with sufficient promptness upon the brakes of the rear cars, where a particularly speedy action was required, and that it would be necessary to devise some other means for cases of special emergency." The Court



## DEFENSES

explained the technology and the flow of pressurized air to the brakes in the patent in suit in the following text and figures:

Upon examination of these defects, it was found that they could only be remedied by securing (1), in cases of emergency, a more abundant discharge of compressed air into the brake cylinder; and (2) an escape of air near to each triple valve without requiring the escaping air to travel all the way back to the engine. The latter device having been already embodied in patent No. 217,838, these features Mr. Westinghouse introduced into the patent in suit, by which a passage was opened directly from the train pipe, filled from the main reservoir on the engine, to the brake cylinder, through which, in cases of emergency, the train-pipe air, instead of being discharged into the atmosphere, could pour directly from the train pipe into the brake cylinder. This operation resulted in charging the brake cylinder and applying the brakes more quickly than before; and also, by reason of the fact that the filling of the brake cylinder from the train pipe on one car made what was, in effect, a local vent for the release of pressure sufficient to operate the valve on the next car behind, each successive valve operated more quickly than when a diminution of pressure was caused by an escape of air only at the locomotive.

The direct passage of the air from the train pipe to the brake cylinder was effected by a valve, 41, colored red in the [following] diagrams, which is never opened except in cases of emergency. In ordinary cases, when the brakes are desired to be applied, sufficient air is released from the train pipe to open the passage from the auxiliary reservoir to the brake cylinder by what is called a 'preliminary traverse' of the piston, 12; but, when a quick action is required, sufficient air is drawn from the train pipe, not only to open this passage, but, by a further traverse of the piston, to shove valve 41 off its port, and introduced air directly from the train pipe to the brake cylinder, as shown in the third drawing [below] set forth.

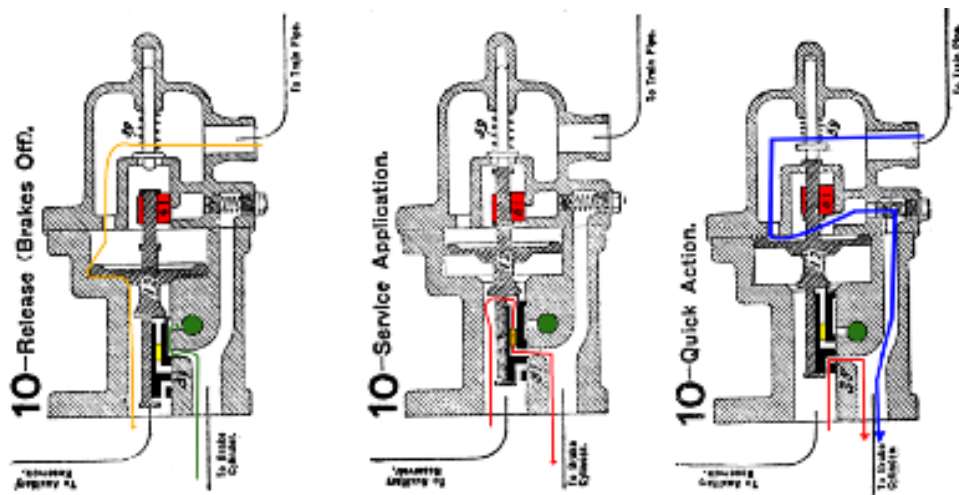

In the foregoing skeleton drawings, from which all details of construction and all figures of reference not necessary for a clear understanding of the structure are omitted, the essential parts are colored, so that their changes of position in the different stages of action can be easily followed.

The access of train-pipe air is shown located at the right end of the structure. . . . Its course [illustrated in orange] from the train pipe to the auxiliary cylinder is through the small port above the upper arm of the piston, 12.

The main valve of the triple is black. Its office is to admit auxiliary reservoir air to brake cylinder.

The quick-action valve is colored red. Its office is to admit train-pipe air to brake cylinder.

The release port is colored green. Its office is to discharge air from brake cylinder, in releasing the brakes.

There is also shown, in yellow, what is known as the 'graduating valve,' the function of which will be hereafter explained. As at present used, the triple valve is in reality a quadruple valve.

The flow or movement of air in the several positions of the structure is also shown by colored lines and arrows, viz.:

Air released from brake cylinder to open air by green arrow.

Air flowing from auxiliary reservoir to brake cylinder, in 'service' application of the brakes, by red line; and air flowing from train pipe to brake cylinder in 'quick-action' application, by blue line.

The Court noted that the invention as patented was not "entirely successful in its practical operation," and then moved on to claim construction, in which the parties argued over whether the patent required the element of an auxiliary valve controlling the passage of air from the train pipe to the brake cylinder. The patent holder argued that the function could be fulfilled by any number of structures, whereas the defendants argued that the auxiliary valve was required. The Court looked to the specification and the prosecution history and concluded that it could "adopt no other construction than to consider it as if the auxiliary valve were inserted in the claim in so many words . . . ."

Finally, the Court turned to the question of infringement:

To what liberality of construction these claims are entitled depends, to a certain extent, upon the character of the invention, and whether it is what is termed, in ordinary parlance, a 'pioneer.' This word, although used somewhat loosely, is commonly understood to denote a patent covering a function never before

performed, a wholly novel device, or one of such novelty and importance as to mark a distinct step in the progress of the art, as distinguished from a mere improvement or perfection of what had gone before. Most conspicuous examples of such patents are the one to Howe, of the sewing machine; to Morse, of the electrical telegraph; and to Bell, of the telephone. The record in this case would indicate that the same honorable appellation might be safely bestowed upon the original air brake of Westinghouse, and perhaps, also, upon his automatic brake. In view of the fact that the invention in this case was never put into successful operation, and was to a limited extent anticipated by the Boyden patent of 1883, it is perhaps an unwarrantable extension of the term to speak of it as a 'pioneer,' although the principle involved subsequently, and through improvements upon this invention, became one of great value to the public. The fact that this invention was first in the line of those which resulted in placing it within the power of an engineer, running a long train, to stop in about half the time and half the distance within which any similar train had stopped, is certainly deserving of recognition, and entitles the patent to a liberality of construction which would not be accorded to an ordinary improvement upon prior devices. At the same time, as hereinafter observed, this liberality must be exercised in subordination to the general principle above stated,—that the function of a machine cannot be patented, and hence that the fact that the defendants' machine performs the same function is not conclusive that it is an infringement.

The device made use of by the defendants is exhibited in patents No. 481,134 and No. 481,135, both dated August 16, 1892, and both of which were granted after the commencement of this suit. There are two forms of this patent, one of which, illustrated in patent No. 481,135, is here given in its three positions. . . .

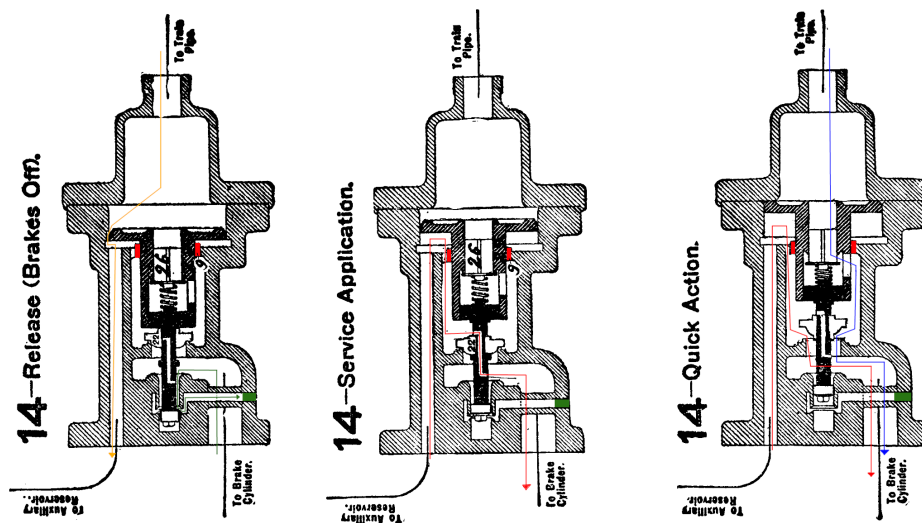

The operation of this device is best shown by the foregoing skeleton drawings.

...

The argument of the defendants in this connection is that in this device there is no auxiliary valve or by-passage, but the quick-action result is effected simply by proportioning the ports and passages of the old triple valve, and using a fixed partition, 9 [colored red in the above diagrams], to divide the piston chamber ... from the main-valve chamber...; that it is this partition which produces the quick action, and that such partition is not a valve, nor the mechanical equivalent of a valve, but merely a metal ring screwed immovably into the triple-valve casing, and serving to divide the piston chamber from the main-valve chamber [to create a substantial pressure differential in quick-action mode]; that this partition was a new element, never before found in triple valves, and introduced a new principle and mode of operation, totally different from anything ever invented by Mr. Westinghouse or any other inventor....

As the graduating valve of the Boyden patent practically does all the work in ordinary cases, and the poppet valve [22] is only called into action in emergency cases, the latter is practically an auxiliary valve, by which we understand, not necessarily an independent valve, nor one of a particular construction, but simply a valve which in emergency cases is called into the assistance of the graduating valve. In this particular the poppet valve of the Boyden device performs practically the same function as the slide valve, 41, of the Westinghouse. It is not material in this connection that it is a poppet valve, while the other is a slide valve, since there is no invention in substituting one valve or spring of familiar shape for another....

...

But, even if it be conceded that the Boyden device corresponds with the letter of the Westinghouse claims, that does not settle conclusively the question of infringement. We have repeatedly held that a charge of infringement is sometimes made out, though the letter of the claims be avoided.... The converse is equally true. The patentee may bring the defendant within the letter of his claims, but if the latter has so far changed the principle of the device that the claims of the patent, literally construed, have ceased to represent his actual invention, he is as little subject to be adjudged an infringer as one who has violated the letter of a statute has to be convicted, when he has done nothing in conflict with its spirit and intent....

We have no desire to qualify the repeated expressions of this court to the effect that, where the invention is functional, and the defendant's device differs from that of the patentee only in form, or in a rearrangement of the same elements of a

## DEFENSES

combination, he would be adjudged an infringer, even if, in certain particulars, his device be an improvement upon that of the patentee. But, after all, even if the patent for a machine be a pioneer, the alleged infringer must have done something more than reach the same result. He must have reached it by substantially the same or similar means, or the rule that the function of a machine cannot be patented is of no practical value. To say that the patentee of a pioneer invention for a new mechanism is entitled to every mechanical device which produces the same result is to hold, in other language, that he is entitled to patent his function.

... Under the very terms of the first and fourth claims of the Westinghouse patent, the infringing device must not only contain an auxiliary valve, or its mechanical equivalent, but it must contain the elements of the combination, "substantially as set forth."

...

Conceding that the functions of the two devices are practically the same, the means used in accomplishing this function are so different that we find it impossible to say, even in favor of a primary patent, that they are mechanical equivalents. While [Boyden's] poppet valve [22], which, for the purposes of this case, we may term the auxiliary valve, is, in its operation, independent of the main valve, the word 'independent' in the claims of the Westinghouse patent evidently refers to a valve auxiliary to the triple valve, and independently located as well as operated. The difference is that in one case [Westinghouse] the air from the train pipe is introduced into the brake cylinder separately and independently from the air from the auxiliary reservoir, while in the other case [Boyden] they unite in the chamber ... and pass through the same valve [26] to the brake cylinder. In the Westinghouse patent there is one valve operated by the direct thrust of the piston, opening a by-passage; in the other, there is a poppet valve also opened by the piston, and another valve, 26, opened by the pressure maintained upon the outside of the partition, 9.

...

We are induced to look with more favor upon this device, not only because it is a novel one, and a manifest departure from the principle of the Westinghouse patent, but because it solved at once, in the simplest manner, the problem of quick action, whereas the Westinghouse patent did not prove to be a success until certain additional members had been incorporated into it. The underlying distinction between the two devices is that in one a separate valve and separate by-passage are provided for the train-pipe air, while in the other the patentee has taken the old triple (or quadruple) valve, and by a slight change in the functions of two of

its valves, and the incorporation of a new element (partition 9), has made a more perfect brake than the one described in the Westinghouse patent. If credit be due to Mr. Westinghouse for having invented the function, Mr. Boyden has certainly exhibited great ingenuity in the discovery of a new and more perfect method of performing such function. If his patent be compared with the later Westinghouse patent, No. 376,837, which appears to have been the first completely successful one, the difference between the two, both in form and principle, becomes still more apparent, and the greater simplicity of the Boyden patent certainly entitles it to a favorable consideration. If the method pursued by the patentee for the performance of the function discovered by him would naturally have suggested the device adopted by the defendants, that is in itself evidence of an intended infringement; but, although Mr. Boyden may have intended to accomplish the same results, the Westinghouse patent, if he had had it before him, would scarcely have suggested the method he adopted to accomplish these results. Under such circumstances, the law entitles him to the rights of an independent inventor.

Upon a careful consideration of the testimony, we have come to the conclusion that the Boyden device is not an infringement of the complainants' patent, and the decree of the circuit court of appeals is therefore affirmed.

### Context & Application

1. The Court states that the reach of the patent depends on whether it is a "pioneer." However, some of the language appears to focus more on whether the accused device is pioneering. How much weight should pioneering patents be given for purposes of the doctrine of equivalents? Should the same weight be given to pioneering accused infringing devices under the reverse doctrine of equivalents? Is the answer dependent on just how pioneering the invention and accused device are in relation to each other? If so, how does this square with the general goals of certainty and predictability for patents?

2. What doctrines have we studied so far that play a similar role to that of the reverse doctrine of equivalents in Westinghouse? Are these doctrines easier to apply? More predictable? Are they as fair?

## D. Experimental Use Defense

*Madey v. Duke University*  
307 F.3d 1351 (Fed. Cir. 2002)

GAJARSA, Circuit Judge.

Dr. John M.J. Madey (“Madey”) appeals from a judgment of the United States District Court for the Middle District of North Carolina. Madey sued Duke University (“Duke”), bringing claims of patent infringement and various other federal and state law claims. After discovery, the district court granted summary judgment in favor of Duke on the remaining claims. For a first set of alleged infringing acts, it held that the experimental use defense applied to Duke’s use of Madey’s patented laser technology. . . .

*Background*

In the mid–1980s Madey was a tenured research professor at Stanford University. At Stanford, he had an innovative laser research program, which was highly regarded in the scientific community. An opportunity arose for Madey to consider leaving Stanford and take a tenured position at Duke. Duke recruited Madey, and in 1988 he left Stanford for a position in Duke’s physics department. In 1989 Madey moved his free electron laser (“FEL”) research lab from Stanford to Duke. The FEL lab contained substantial equipment, requiring Duke to build an addition to its physics building to house the lab. In addition, during his time at Stanford, Madey had obtained sole ownership of two patents practiced by some of the equipment in the FEL lab.

At Duke, Madey served for almost a decade as director of the FEL lab. During that time the lab continued to achieve success in both research funding and scientific breakthroughs. However, a dispute arose between Madey and Duke. Duke contends that, despite his scientific prowess, Madey ineffectively managed the lab. Madey contends that Duke sought to use the lab's equipment for research areas outside the allocated scope of certain government funding, and that when he objected, Duke sought to remove him as lab director. Duke eventually did remove Madey as director of the lab in 1997. The removal is not at issue in this appeal, however, it is the genesis of this unique patent infringement case. As a result of the removal, Madey resigned from Duke in 1998. Duke, however, continued to operate some of the equipment in the lab. Madey then sued Duke for patent infringement of his two patents, and brought a variety of other claims.

One of Madey’s patents, U.S. Patent No. 4,641,103 (“the ‘103 patent”), covers a “Microwave Electron Gun” used in connection with free electron lasers. The other patent, U.S. Patent No. 5,130,994 (“the ‘994 patent”), is titled “Free–Electron Laser Oscillator For Simultaneous Narrow Spectral Resolution And Fast Time Resolution Spectroscopy.” The

details of these two patents are not material to the issues on appeal. Their use in the lab, however, as embodied in certain equipment, is central to this appeal.

...

The three alleged infringing devices are the Mark III FEL, the Storage Ring FEL, and the Microwave Gun Test Stand. Although it is not clear from the record, perhaps because Duke defended by asserting experimental use and government license defenses, Duke seems to concede that the alleged infringing devices and methods read on the claims of the patents. Although the three devices were housed in Duke's physics facilities, the Microwave Gun Test Stand was not Duke's asset, but rather belonged to North Carolina Central University ("NCCU").

...

Among Duke's motions for summary judgment, two are relevant on appeal, entitled by the district court as: (i) the "Patent Motion;" and (ii) the "Test Stand Gun Motion."

The district court acknowledged a common law "exception" for patent infringement liability for uses that, in the district court's words, are "solely for research, academic or experimental purposes." The district court recognized the debate over the scope of the experimental use defense, but cited this court's opinion in *Embrex, Inc. v. Service Engineering Corp.*, 216 F.3d 1343, 1349 (Fed. Cir. 2000) to hold that the defense was viable for experimental, non-profit purposes.

#### *Discussion*

On appeal, Madey asserts three primary errors related to experimental use. First, Madey claims that the district court improperly shifted the burden to Madey to prove that Duke's use was not experimental. Second, Madey argues that the district court applied an overly broad version of the very narrow experimental use defense inconsistent with our precedent. Third, Madey attacks the supporting evidence relied on by the district court as overly general and not indicative of the specific propositions and findings required by the experimental use defense, and further argues that there is no support in the record before us to allow any court to apply the very narrow experimental use defense to Duke's ongoing FEL lab operation. We substantially agree with Madey on all three points. In addition, Madey makes a threshold argument concerning the continued existence of the experimental use doctrine in any form, which we turn to first. Our precedent, to which we are bound, continues to recognize the judicially created experimental use defense, however, in a very limited form.

#### *The Experimental Use Defense*

Citing the concurring opinion in *Embrex*, Madey contends that the Supreme Court's opinion in *Warner-Jenkinson Co. v. Hilton Davis Chem. Co.*, 520 U.S. 17 (1997) eliminates the



experimental use defense. *Embrex*, 216 F.3d at 1352–53 (Rader, J., concurring). The Supreme Court held in *Warner–Jenkinson* that intent plays no role in the application of the doctrine of equivalents. Madey implicitly argues that the experimental use defense necessarily incorporates an intent inquiry, and thus is inconsistent with *Warner–Jenkinson*. Like the majority in *Embrex*, we do not view such an inconsistency as inescapable, and conclude the experimental use defense persists albeit in the very narrow form articulated by this court . . . .

*The District Court Improperly Shifted the Burden to Madey*

As a precursor to the burden-shifting issue, Madey argues that the experimental use defense is an affirmative defense that Duke must plead or lose. We disagree. Madey points to no source of authority for its assertion that experimental use is an affirmative defense. Indeed, we have referred to the defense in a variety of ways. Given this lack of precise treatment in the precedent, Madey has no basis to support its affirmative defense argument. The district court and the parties in the present case joined the issue during the summary judgment briefing. We see no mandate from our precedent, nor any compelling reason from other considerations, why the opportunity to raise the defense if not raised in the responsive pleading should not also be available at the later stages of a case, within the procedural discretion typically afforded the trial court judge.

The district court held that in order for Madey to overcome his burden to establish actionable infringement, he must establish that Duke did not use the patent-covered free electron laser equipment solely for experimental or other non-profit purposes. Madey argues that this improperly shifts the burden to the patentee and conflates the experimental use defense with the initial infringement inquiry.

We agree with Madey that the district court improperly shifted the burden to him. The district court folded the experimental use defense into the baseline assessment as to whether Duke infringed the patents. Duke characterizes the district court's holding as expressing the following sequence: first, the court recognized that Madey carried his burden of proof on infringement; second, the court held that Duke carried its burden of proof on the experimental use defense; and third, the court held that Madey was unable to marshal sufficient evidence to rebut Duke's shifting of the burden. We disagree with Duke's reading of the district court's opinion. The district court explicitly contradicts Duke's argument by stating that Madey failed to "meet its burden to establish patent infringement by a preponderance of the evidence." This statement is an assessment of whether Madey supported his initial infringement claim. It is not an assessment of which party carried or shifted the burden of evidence related to the experimental use defense. Thus, the district court did not conclude that Madey failed to rebut Duke's assertion of the experimental use defense. Instead, it erroneously required Madey to show as a part of

his initial claim that Duke's use was not experimental. The defense, if available at all, must be established by Duke.

*The District Court's Overly Broad Conception of Experimental Use*

Madey argues, and we agree, that the district court had an overly broad conception of the very narrow and strictly limited experimental use defense. The district court stated that the experimental use defense inoculated uses that "were solely for research, academic, or experimental purposes," and that the defense covered use that "is made for experimental, non-profit purposes only." Both formulations are too broad and stand in sharp contrast to our admonitions . . . that the experimental use defense is very narrow and strictly limited. In *Embrex*, we . . . [held] that the defense was very narrow and limited to actions performed "for amusement, to satisfy idle curiosity, or for strictly philosophical inquiry." Further, use does not qualify for the experimental use defense when it is undertaken in the "guise of scientific inquiry" but has "definite, cognizable, and not insubstantial commercial purposes." The concurring opinion in *Embrex* expresses a similar view: use is disqualified from the defense if it has the "slightest commercial implication." Moreover, use in keeping with the legitimate business of the alleged infringer does not qualify for the experimental use defense. . . .

. . .

Our precedent clearly does not immunize use that is in any way commercial in nature. Similarly, our precedent does not immunize any conduct that is in keeping with the alleged infringer's legitimate business, regardless of commercial implications. For example, major research universities, such as Duke, often sanction and fund research projects with arguably no commercial application whatsoever. However, these projects unmistakably further the institution's legitimate business objectives, including educating and enlightening students and faculty participating in these projects. These projects also serve, for example, to increase the status of the institution and lure lucrative research grants, students and faculty.

In short, regardless of whether a particular institution or entity is engaged in an endeavor for commercial gain, so long as the act is in furtherance of the alleged infringer's legitimate business and is not solely for amusement, to satisfy idle curiosity, or for strictly philosophical inquiry, the act does not qualify for the very narrow and strictly limited experimental use defense. Moreover, the profit or non-profit status of the user is not determinative.

In the present case, the district court attached too great a weight to the non-profit, educational status of Duke, effectively suppressing the fact that Duke's acts appear to be in accordance with any reasonable interpretation of Duke's legitimate business objectives.<sup>7</sup>

## DEFENSES

<sup>7</sup> Duke's patent and licensing policy may support its primary function as an educational institution. See Duke University Policy on Inventions, Patents, and Technology Transfer (1996). Duke, however, like other major research institutions of higher learning, is not shy in pursuing an aggressive patent licensing program from which it derives a not insubstantial revenue stream.

On remand, the district court will have to significantly narrow and limit its conception of the experimental use defense. The correct focus should not be on the non-profit status of Duke but on the legitimate business Duke is involved in and whether or not the use was solely for amusement, to satisfy idle curiosity, or for strictly philosophical inquiry.

### Context & Application

1. How does the Federal Circuit define "experimental use" in *Madey*? What kinds of uses can you imagine that might qualify?
2. Do you think that the doctrine of experimental use as described in *Madey* represents the optimal balance of patent policy objectives? If not, what criteria would you use to draw the line between non-infringing, experimental use and infringing use?
3. Be sure to keep this kind of "experimental use" separate from the doctrine we saw in Chapter 6. How are they similar? How are they different? What impact do the different kinds of experimental use have?

### E. Prior User Rights

Patents are meant to encourage development and disclosure of novel inventions, but as we have seen, some inventors forego patenting and rely instead on trade secret protection. These inventors run the risk that someone else will obtain a patent that covers their invention, subjecting the initial inventor to infringement liability. Since 1999, section 273 of the Patent Act has included a defense for prior users of a patented technology. This defense was substantially revised by the America Invents Act.

In order to prevail under the current version of the prior commercial use defense, the alleged infringer must show that at least 1 year prior to the patentee's effective filing date, the alleged infringer commercially used the invention in the United States, in good faith, in connection with either (i) an internal commercial use, or (ii) an arm's length sale or transfer of the end result of such commercial use. 35 U.S.C. § 273(a)-(b). The patentee might be able to rely on a date earlier than the effective filing date if they disclosed and then filed under the § 102(b) grace periods.

This defense is, however, sharply limited. The defense is personal and non-transferrable. It is also site restricted—the right may not be transferred, divided, or assigned, unless the transfer is made as part of a sale of the underlying business. 35 U.S.C. § 273(e)(1). The defense only covers activities already engaged in by the prior user, 35 U.S.C. § 273(e)(3), and if the user at any point abandons its use, it cannot later begin again. 35 U.S.C. § 273(e)(4). And, the defense is not available against patents originally owned by universities. 35 U.S.C. § 273(e)(5).

Even a successful assertion of the prior commercial use defense will not, by itself, form a sufficient basis for invalidating the patent under Sections 102 or 103. Can you see why? See 35 U.S.C. § 273(g). And an infringer who asserts the defense and loses will be ordered to pay the patentee's attorney fees. 35 U.S.C. § 273(f), 285. These limitations have made the prior use defense relatively unappealing. Of course, the types of inventions that are amenable to being kept as trade secrets may also be those for which infringement is difficult to detect, adding to the reasons that we may not see the defense asserted very often.

## F. Exhaustion

In *Adams v. Burke*, the Supreme Court reviewed a patent infringement claim arising from the use of patented coffin lids by an undertaker who bought the lids from a licensed manufacturer who had been assigned all rights in the patent—but only within ten miles of Boston. An undertaker purchased a coffin lid from the manufacturer within the prescribed area, but the lid was subsequently used farther away. The Court held that the right to sell may indeed have been restricted by geographical area, but that the purchaser “acquired the right to [the] use of it freed from any claim of the patentee . . .” 84 U.S. (17 Wall.) 453, 457 (1873). The Court based its holding on the single reward theory—that the patent holder had been rewarded for the first use of the invention, which exhausted their rights in that particular good. The doctrine of exhaustion, also known as “first sale,” is based both on this idea that the patent holder need only be rewarded the first time a patented good is sold, and on the corollary idea that once goods are circulating in commerce, there should not be restraints on alienation of those goods. That is, consumers who have made authorized purchases of goods subject to patent rights should be free to resell those goods.

*Quanta Computer, Inc. v. LG Electronics, Inc.*

553 U.S. 617 (2008)

Justice THOMAS delivered the opinion of the Court.

For over 150 years this Court has applied the doctrine of patent exhaustion to limit the patent rights that survive the initial authorized sale of a patented item. In this case, we decide whether patent exhaustion applies to the sale of components of a patented system that must be combined with additional components in order to practice the patented methods. The Court of Appeals for the Federal Circuit held that the doctrine does not apply to method patents at all and, in the alternative, that it does not apply here because the sales were not authorized by the license agreement. We disagree on both scores. Because the exhaustion doctrine applies to method patents, and because the license authorizes the sale of components that substantially embody the patents in suit, the sale exhausted the patents.

## I

Respondent LG Electronics, Inc. (LGE), purchased a portfolio of computer technology patents in 1999, including the three patents at issue here.... The main functions of a computer system are carried out on a microprocessor, or central processing unit, which interprets program instructions, processes data, and controls other devices in the system. A set of wires, or bus, connects the microprocessor to a chipset, which transfers data between the microprocessor and other devices, including the keyboard, mouse, monitor, hard drive, memory, and disk drives. [The LGE patents-in-suit claim methods for ensuring accurate reading and writing of data by monitoring data requests and traffic across these components of a computer system.]

...

LGE licensed a patent portfolio, including the LGE Patents, to Intel Corporation (Intel). The cross-licensing agreement (License Agreement) permits Intel to manufacture and sell microprocessors and chipsets that use the LGE Patents (Intel Products). The License Agreement authorizes Intel to ““make, use, sell (directly or indirectly), offer to sell, import or otherwise dispose of”” its own products practicing the LGE Patents. Notwithstanding this broad language, the License Agreement contains some limitations. Relevant here, it stipulates that no license

is granted by either party hereto ... to any third party for the combination by a third party of Licensed Products of either party with items, components, or the like acquired ... from sources other than a party hereto, or for the use, import, offer for sale or sale of such combination.

The License Agreement purports not to alter the usual rules of patent exhaustion, however, providing that, “notwithstanding anything to the contrary contained in this Agreement, the parties agree that nothing herein shall in any way limit or alter the effect of patent exhaustion that would otherwise apply when a party hereto sells any of its Licensed Products.”

In a separate agreement (Master Agreement), Intel agreed to give written notice to its own customers informing them that, while it had obtained a broad license “ensuring that any Intel product that you purchase is licensed by LGE and thus does not infringe any patent held by LGE,” the license “does not extend, expressly or by implication, to any product that you make by combining an Intel product with any non-Intel product.” The Master Agreement also provides that “a breach of this Agreement shall have no effect on and shall not be grounds for termination of the Patent License.”

Petitioners, including Quanta Computer (collectively Quanta), are a group of computer manufacturers. Quanta purchased microprocessors and chipsets from Intel and received the notice required by the Master Agreement. Nonetheless, Quanta manufactured computers using Intel parts in combination with non-Intel memory and buses in ways that practice the LGE Patents. Quanta does not modify the Intel components and follows Intel’s specifications to incorporate the parts into its own systems.

LGE filed a complaint against Quanta, asserting that the combination of the Intel Products with non-Intel memory and buses infringed the LGE Patents. The District Court granted summary judgment to Quanta, holding that, for purposes of the patent exhaustion doctrine, the license LGE granted to Intel resulted in forfeiture of any potential infringement actions against legitimate purchasers of the Intel Products. The court found that, although the Intel Products do not fully practice any of the patents at issue, they have no reasonable noninfringing use and therefore their authorized sale exhausted patent rights in the completed computers under *United States v. Univis Lens Co.*, 316 U.S. 241 (1942). In a subsequent order limiting its summary judgment ruling, the court held that patent exhaustion applies only to apparatus or composition-of-matter claims that describe a physical object, and does not apply to process, or method, claims that describe operations to make or use a product. Because each of the LGE Patents includes method claims, exhaustion did not apply.

The Court of Appeals for the Federal Circuit affirmed in part and reversed in part. It agreed that the doctrine of patent exhaustion does not apply to method claims. In the alternative, it concluded that exhaustion did not apply because LGE did not license Intel to sell the Intel Products to Quanta for use in combination with non-Intel products.

## DEFENSES

### II

The longstanding doctrine of patent exhaustion provides that the initial authorized sale of a patented item terminates all patent rights to that item. . . .

. . .

This Court most recently discussed patent exhaustion in *Univis*, on which the District Court relied. *Univis Lens Company*, the holder of patents on eyeglass lenses, licensed a purchaser to manufacture lens blanks by fusing together different lens segments to create bi- and tri-focal lenses and to sell them to other Univis licensees at agreed-upon rates. Wholesalers were licensed to grind the blanks into the patented finished lenses, which they would then sell to Univis-licensed prescription retailers for resale at a fixed rate. Finishing retailers, after grinding the blanks into patented lenses, would sell the finished lenses to consumers at the same fixed rate. The United States sued Univis under the Sherman Act, 15 U.S.C. §§ 1, 3, 15, alleging unlawful restraints on trade. Univis asserted its patent monopoly rights as a defense to the antitrust suit. The Court granted certiorari to determine whether Univis' patent monopoly survived the sale of the lens blanks by the licensed manufacturer and therefore shielded Univis' pricing scheme from the Sherman Act.

The Court assumed that the Univis patents containing claims for finished lenses were practiced in part by the wholesalers and finishing retailers who ground the blanks into lenses, and held that the sale of the lens blanks exhausted the patents on the finished lenses. *Univis*, 316 U.S., at 248–249. The Court explained that the lens blanks “embodied essential features of the patented device and were without utility until ground and polished as the finished lens of the patent.” The Court noted that

where one has sold an uncompleted article which, because it embodies essential features of his patented invention, is within the protection of his patent, and has destined the article to be finished by the purchaser in conformity to the patent, he has sold his invention so far as it is or may be embodied in that particular article.

*Id.*, at 250–251. In sum, the Court concluded that the traditional bar on patent restrictions following the sale of an item applies when the item sufficiently embodies the patent—even if it does not completely practice the patent—such that its only and intended use is to be finished under the terms of the patent.

With this history of the patent exhaustion doctrine in mind, we turn to the parties' arguments.

## III

## A

LGE argues that the exhaustion doctrine is inapplicable here because it does not apply to method claims, which are contained in each of the LGE Patents. LGE reasons that, because method patents are linked not to a tangible article but to a process, they can never be exhausted through a sale. Rather, practicing the patent—which occurs upon each use of an article embodying a method patent—is permissible only to the extent rights are transferred in an assignment contract. Quanta, in turn, argues that there is no reason to preclude exhaustion of method claims, and points out that both this Court and the Federal Circuit have applied exhaustion to method claims. It argues that any other rule would allow patent holders to avoid exhaustion entirely by inserting method claims in their patent specifications.

Quanta has the better of this argument. Nothing in this Court’s approach to patent exhaustion supports LGE’s argument that method patents cannot be exhausted. It is true that a patented method may not be sold in the same way as an article or device, but methods nonetheless may be “embodied” in a product, the sale of which exhausts patent rights. Our precedents do not differentiate transactions involving embodiments of patented methods or processes from those involving patented apparatuses or materials. To the contrary, this Court has repeatedly held that method patents were exhausted by the sale of an item that embodied the method. In *Ethyl Gasoline Corp. v. United States*, 309 U.S. 436, 446, 457 (1940), for example, the Court held that the sale of a motor fuel produced under one patent also exhausted the patent for a method of using the fuel in combustion motors. Similarly, as previously described, *Univis* held that the sale of optical lens blanks that partially practiced a patent exhausted the method patents that were not completely practiced until the blanks were ground into lenses. 316 U.S., at 248–251.

These cases rest on solid footing. Eliminating exhaustion for method patents would seriously undermine the exhaustion doctrine. Patentees seeking to avoid patent exhaustion could simply draft their patent claims to describe a method rather than an apparatus. . . .

This case illustrates the danger of allowing such an end-run around exhaustion. On LGE’s theory, although Intel is authorized to sell a completed computer system that practices the LGE Patents, any downstream purchasers of the system could nonetheless be liable for patent infringement. Such a result would violate the longstanding principle that, when a patented item is “once lawfully made and sold, there is no restriction on its use to be implied for the benefit of the patentee.” *Adams*, 17 Wall., at 457. We therefore reject LGE’s argument that method claims, as a category, are never exhaustible.



## DEFENSES

### B

We next consider the extent to which a product must embody a patent in order to trigger exhaustion. Quanta argues that, although sales of an incomplete article do not necessarily exhaust the patent in that article, the sale of the microprocessors and chipsets exhausted LGE's patents in the same way the sale of the lens blanks exhausted the patents in *Univis*. Just as the lens blanks in *Univis* did not fully practice the patents at issue because they had not been ground into finished lenses, Quanta observes, the Intel Products cannot practice the LGE Patents—or indeed, function at all—until they are combined with memory and buses in a computer system. If, as in *Univis*, patent rights are exhausted by the sale of the incomplete item, then LGE has no postsale right to require that the patents be practiced using only Intel parts. Quanta also argues that exhaustion doctrine will be a dead letter unless it is triggered by the sale of components that essentially, even if not completely, embody an invention. Otherwise, patent holders could authorize the sale of computers that are complete with the exception of one minor step—say, inserting the microprocessor into a socket—and extend their rights through each downstream purchaser all the way to the end user.

LGE, for its part, argues that *Univis* is inapplicable here . . . because the Intel Products are analogous to individual elements of a combination patent, and allowing sale of those components to exhaust the patent would impermissibly “ascribe to one element of the patented combination the status of the patented invention in itself.” *Aro Mfg. Co. v. Convertible Top Replacement Co.*, 365 U.S. 336, 344–345 (1961).

We agree with Quanta that *Univis* governs this case. As the Court there explained, exhaustion was triggered by the sale of the lens blanks because their only reasonable and intended use was to practice the patent and because they “embodied essential features of the patented invention.” 316 U.S., at 249–251. Each of those attributes is shared by the microprocessors and chipsets Intel sold to Quanta under the License Agreement.

First, *Univis* held that “the authorized sale of an article which is capable of use only in practicing the patent is a relinquishment of the patent monopoly with respect to the article sold.” The lens blanks in *Univis* met this standard because they were “without utility until [they were] ground and polished as the finished lens of the patent.” Accordingly, “the only object of the sale was to enable the finishing retailer] to grind and polish it for use as a lens by the prospective wearer.” Here, LGE has suggested no reasonable use for the Intel Products other than incorporating them into computer systems that practice the LGE Patents. Nor can we discern one: A microprocessor or chipset cannot function until it is connected to buses and memory. And here, as in *Univis*, the only apparent object of Intel's sales to Quanta was to permit Quanta to incorporate the Intel Products into computers that would practice the patents.

Second, the lens blanks in *Univis* “embodied essential features of the patented invention.” The essential, or inventive, feature of the Univis lens patents was the fusing together of different lens segments to create bi- and trifocal lenses. The finishing process performed by the finishing and prescription retailers after the fusing was not unique. . . .

...

While the Court assumed that the finishing process was covered by the patents and the District Court found that it was necessary to make a working lens, the grinding process was not central to the patents. That standard process was not included in detail in any of the patents and was not referred to at all in two of the patents. . . .

Like the Univis lens blanks, the Intel Products constitute a material part of the patented invention and all but completely practice the patent. Here, as in *Univis*, the incomplete article substantially embodies the patent because the only step necessary to practice the patent is the application of common processes or the addition of standard parts. Everything inventive about each patent is embodied in the Intel Products. . . . Naturally, the Intel Products cannot carry out these functions unless they are attached to memory and buses, but those additions are standard components in the system, providing the material that enables the microprocessors and chipsets to function. The Intel Products were specifically designed to function only when memory or buses are attached; Quanta was not required to make any creative or inventive decision when it added those parts. Indeed, Quanta had no alternative but to follow Intel’s specifications in incorporating the Intel Products into its computers because it did not know their internal structure, which Intel guards as a trade secret. Intel all but practiced the patent itself by designing its products to practice the patents, lacking only the addition of standard parts.

...

With regard to LGE’s argument that exhaustion does not apply across patents, we agree on the general principle: The sale of a device that practices patent A does not, by virtue of practicing patent A, exhaust patent B. But if the device practices patent A *while substantially embodying* patent B, its relationship to patent A does not prevent exhaustion of patent B. For example, if the Univis lens blanks had been composed of shatter-resistant glass under patent A, the blanks would nonetheless have substantially embodied, and therefore exhausted, patent B for the finished lenses. This case is no different. While each Intel microprocessor and chipset practices thousands of individual patents, including some LGE patents not at issue in this case, the exhaustion analysis is not altered by the fact that more than one patent is practiced by the same product. The relevant consideration is whether the Intel Products that partially practice a patent—by, for example, embodying its essential features—exhaust *that* patent.

## DEFENSES

Finally, LGE's reliance on *Aro* is misplaced because that case dealt only with the question whether replacement of one part of a patented combination infringes the patent. . . . *Aro* is not squarely applicable to the exhaustion of patents like the LGE Patents that do not disclose a new combination of existing parts. . . . *Aro*'s warning that no element can be viewed as central to or equivalent to the invention is specific to the context in which the combination itself is the only inventive aspect of the patent. In this case, the inventive part of the patent is not the fact that memory and buses are combined with a microprocessor or chipset; rather, it is included in the design of the Intel Products themselves and the way these products access the memory or bus.

### C

Having concluded that the Intel Products embodied the patents, we next consider whether their sale to Quanta exhausted LGE's patent rights. Exhaustion is triggered only by a sale authorized by the patent holder.

LGE argues that there was no authorized sale here because the License Agreement does not permit Intel to sell its products for use in combination with non-Intel products to practice the LGE Patents. It cites *General Talking Pictures Corp. v. Western Elec. Co.*, 304 U.S. 175, (1938), and *General Talking Pictures Corp. v. Western Elec. Co.*, 305 U.S. 124 (1938), in which the manufacturer sold patented amplifiers for commercial use, thereby breaching a license that limited the buyer to selling the amplifiers for private and home use. The Court held that exhaustion did not apply because the manufacturer had no authority to sell the amplifiers for commercial use, and the manufacturer "could not convey to petitioner what both knew it was not authorized to sell." 304 U.S., at 181. LGE argues that the same principle applies here: Intel could not convey to Quanta what both knew it was not authorized to sell, i.e., the right to practice the patents with non-Intel parts.

LGE overlooks important aspects of the structure of the Intel-LGE transaction. Nothing in the License Agreement restricts Intel's right to sell its microprocessors and chipsets to purchasers who intend to combine them with non-Intel parts. It broadly permits Intel to "make, use, or sell" products free of LGE's patent claims. To be sure, LGE did require Intel to give notice to its customers, including Quanta, that LGE had not licensed those customers to practice its patents. But neither party contends that Intel breached the agreement in that respect. In any event, the provision requiring notice to Quanta appeared only in the Master Agreement, and LGE does not suggest that a breach of that agreement would constitute a breach of the License Agreement. Hence, Intel's authority to sell its products embodying the LGE Patents was not conditioned on the notice or on Quanta's decision to abide by LGE's directions in that notice.

## CHAPTER 10

LGE points out that the License Agreement specifically disclaimed any license to third parties to practice the patents by combining licensed products with other components. But the question whether third parties received implied licenses is irrelevant because Quanta asserts its right to practice the patents based not on implied license but on exhaustion. And exhaustion turns only on Intel's own license to sell products practicing the LGE Patents.

Alternatively, LGE invokes the principle that patent exhaustion does not apply to postsale restrictions on "making" an article. But this is simply a rephrasing of its argument that combining the Intel Products with other components adds more than standard finishing to complete a patented article. As explained above, making a product that substantially embodies a patent is, for exhaustion purposes, no different from making the patented article itself. In other words, no further "making" results from the addition of standard parts—here, the buses and memory—to a product that already substantially embodies the patent.

The License Agreement authorized Intel to sell products that practiced the LGE Patents. No conditions limited Intel's authority to sell products substantially embodying the patents. Because Intel was authorized to sell its products to Quanta, the doctrine of patent exhaustion prevents LGE from further asserting its patent rights with respect to the patents substantially embodied by those products.

### IV

The authorized sale of an article that substantially embodies a patent exhausts the patent holder's rights and prevents the patent holder from invoking patent law to control postsale use of the article. Here, LGE licensed Intel to practice any of its patents and to sell products practicing those patents. Intel's microprocessors and chipsets substantially embodied the LGE Patents because they had no reasonable noninfringing use and included all the inventive aspects of the patented methods. Nothing in the License Agreement limited Intel's ability to sell its products practicing the LGE Patents. Intel's authorized sale to Quanta thus took its products outside the scope of the patent monopoly, and as a result, LGE can no longer assert its patent rights against Quanta. Accordingly, the judgment of the Court of Appeals is reversed.

### Context & Application

1. Other areas of intellectual property law also adhere to rules of exhaustion. In copyright law, the defense has been codified. 17 U.S.C. § 109. In trademark law, as in patent law, the doctrine arises from common law. *See, e.g., Champion Spark Plug Co. v. Sanders*, 331 U.S. 125 (1947); *Prestonettes, Inc. v. Coty*, 264 US 359 (1924). What are the

justifications for the exhaustion doctrine? When you buy or sell a used car, do you stop to consider the state of the various patents and copyrights covering the technology it contains? What about when the technology is digital in nature? And, consider whether you own or lease the various digital technologies you think of as “yours.” Can you sell them? See AARON PERZANOWSKI & JASON SCHULTZ, *THE END OF OWNERSHIP: PERSONAL PROPERTY IN THE DIGITAL ECONOMY* (2016); Molly Shaffer Van Houweling, *The New Servitudes*, 96 GEO. L. J. 885 (2008).

2. One area where exhaustion is consistently revisited is in regards to self-replicating technology. In *Bowman v. Monsanto*, the Supreme Court was faced with a patent infringement claim brought by Monsanto, which holds patents on genetically modified soybean seeds. The Court held that the farmer who bought patented seeds from a grain elevator and, without authorization, planted the seeds and harvested the newly-grown seed crop had infringed Monsanto’s patents, based in part on Monsanto’s restrictive licensing agreement. Bowman claimed that the authorized sale of seeds to the grain elevator exhausted Monsanto’s patent rights, such that the company could not claim infringement based on a subsequent purchaser’s use of the seeds. The Supreme Court held that while Bowman could have consumed the seed, fed it to animals, or sold it to others, his use of the patented seeds to “make” new, patented seeds was infringement. 569 U.S. 278 (2013).

3. The Supreme Court has also recently heard cases on international exhaustion in both the copyright and patent law contexts. Intellectual property rights are generally considered territorial—foreign sales and uses of goods that are patented in the United States do not generally result in infringement of a U.S. patent. So what happens when the first, authorized sale of a good is abroad—and then the purchaser imports the goods into the United States. There has been no first sale in the United States. At the same time, with the increase in international manufacturing and sales, arguments against restrictions on downstream use would seem to counsel for an international rule of exhaustion.

In 2017, in *Impression Products, Inc. v. Lexmark Inc.*, the Court held that the authorized sale of a patented product, anywhere in the world, exhausts the patent-holder’s rights in that product. Impression Products had bought used Lexmark toner cartridges abroad from lawful purchasers, refilled them, and then imported and sold them in the United States. The Court overturned Federal Circuit case law holding that post-sale restrictions and foreign sales preserve a U.S. patent-holder’s right to sue for infringement. The Court stated:

Patent exhaustion . . . has its roots in the antipathy toward restraints on alienation . . . and nothing in the text or history of the Patent Act shows that Congress intended to confine that borderless common law principle to domestic sales. . . . Exhaustion does not depend on whether the patentee receives a premium for

## CHAPTER 10

selling in the United States, or the type of rights that buyers expect to receive. As a result, restrictions and location are irrelevant; what matters is the patentee's decision to make a sale.

137 S.Ct. at 1536-38. This ruling made patent law consistent with Copyright in the area of international exhaustion, but it was counter to the United States' policy position in its negotiations of international intellectual property and trade treaties. For more on the history and policy behind international exhaustion in patent law, see Sarah R. Wasserman Rajec, *Free Trade in Patented Goods: International Exhaustion for Patents*, 29 BERKELEY TECH. L.J. 317 (2014). For an argument that international patent exhaustion will likely result in lower prices of patented goods in the United States and higher prices abroad, to the detriment of lower-income countries, see Daniel J. Hemel & Lisa Larrimore Ouellette, *Trade and Tradeoffs: The Case of International Patent Exhaustion*, 116 COLUM. L. REV. SIDEBAR 17, 18 (2016).

## 11. PLANTS

Plant protection is an area of increasing interest to the practicing bar, due in no small part to the legalization—at least in some states—of cannabis. Arguments about plant protection have also come up in important § 101 cases like *Diamond v. Chakrabarty*. To understand those arguments, it is helpful to know a bit more about the various regimes that protect and encourage plant development. The study of these regimes also provides a helpful lens through which we can consider important big-picture questions such as: What types of things and processes should be protected by patents? And if not patents, what type (or types) of protection should be available for those things? Finally, studying plant protection gives us more opportunities to practice statutory interpretation—a vital practical skill for any lawyer.

In the United States, there are three different forms of intellectual property protection available for plants: (1) plant patents; (2) plant variety protection; and (3) utility patents. This chapter will consider all three forms of protection in the order in which they became available for plants.

### A. Plant Patents

The Plant Patent Act of 1930 (PPA) was the first statute to provide intellectual property protection for plants anywhere in the world. See Keith Aoki, *Seeds of Dispute: Intellectual-Property Rights and Agricultural Biodiversity*, 3 GOLDEN GATE U. ENVTL. L.J. 79, 96 (2009). This act was passed following lobbying from plant breeders, “primarily from rose and fruit tree breeders.” Donald G. Daus, *Plant Patents: A Potentially Extinct Variety*, 21 ECONOMIC BOTANY 388, 388 (1967). The first plant patent was issued for a new variety of rose. See *Climbing or Trailing Rose*, U.S. Patent No. PP1 (filed Aug. 6, 1930).

Today, the statutory subject matter provision for plant patents is codified at 35 U.S.C. § 161. That section provides:

Whoever invents or discovers and asexually reproduces any distinct and new variety of plant, including cultivated sports, mutants, hybrids, and newly found seedlings, other than a tuber propagated plant or a plant found in an uncultivated state, may obtain a patent therefor, subject to the conditions and requirements of this title.

The provisions of this title relating to patents for inventions shall apply to patents for plants, except as otherwise provided.

If it's been a while since you took biology, the USPTO has explained that:

Asexually propagated plants are those that are reproduced by means other than from seeds, such as by the rooting of cuttings, by layering, budding, grafting, inarching, etc. Plants capable of sexual reproduction are not excluded from consideration if they have also been asexually reproduced.

U.S. DEP'T OF COMMERCE, PATENT & TRADEMARK OFFICE, MANUAL OF PATENT EXAMINING PROCEDURE § 1601 (9th ed. Jan. 2018) ("MPEP"). The C.C.P.A. interpreted "plant" in accordance with its common English meaning, not in the "strict, scientific sense" of that word. *See In re Arzberger*, 112 F.2d 834, 838 (C.C.P.A. 1940). Thus, bacteria have long been considered nonstatutory subject matter. *Id.*

Note that § 161 excludes "tuber propagated plant[s]." According to one commentator: "The exclusion of tuber propagated plants, [a category] which includes only Irish potatoes and Jerusalem artichokes, was a political rather than technical distinction. The rationale for this exclusion is that for tuber propagated plants the propagating and edible portions of the plant are the same." Nicholas J. Seay, *Protecting the Seeds of Innovation: Patenting Plants*, 16 AIPLA Q.J. 418, 420 (1989). *See also* MPEP § 1601. You may know Jerusalem artichokes as "sunchokes." *See* DEREK B. MUNRO, VEGETABLES OF CANADA 213 (1997). Given the time period, you can see why Congress might have been cautious about limiting access to important food supplies like potatoes. But other factors may have been at play:

Another possible reason for [the tuber] exclusion was that the Department of Agriculture wished to keep its own potato-breeding project outside the terms of the Act. Paul Stark later said that a reason for the exclusion was that because potatoes were readily available and used both as a food source and for the growing of plants, infringement of a potato plant patent would have been 'easy' and 'widespread,' thereby making enforcement absurd."

*See also* Alain Pottage & Brad Sherman, *Organisms and Manufactures: On the History of Plant Inventions*, 31 MELB. U. L. REV. 539, 549 (2007).

As we've seen, § 161 states that "[t]he provisions of this title relating to patents for inventions shall apply to patents for plants, except as otherwise provided." What is "otherwise provided"? Sections 161–164 of the Patent Act provide specific rules that apply only to plant patents. Otherwise, the provisions of the Patent Act that apply to utility patents also apply to plant patents. So, for example, a patentable plant must be novel and nonobvious. 35 U.S.C. §§ 102, 103. And a plant patent lasts 20 years from its effective filing date. *See* 35 U.S.C. § 154(a)(2); MPEP § 1601.

Plant patent claims are very different than utility patent claims. A plant patent can only have one claim, 37 C.F.R. § 1.164, and that claim "shall be in formal terms to the plant



## PLANTS

shown and described,” 35 U.S.C. § 162. *See also* 37 C.F.R. § 1.153(a) (setting similar rules for design patents). According to the USPTO:

A plant patent is granted only on the entire plant. Only one claim is necessary and only one is permitted. A method claim in a plant patent application is improper. An example of a proper claim would be “A new and distinct variety of hybrid tea rose plant, substantially as illustrated and described herein.”

MPEP § 1605. Because the plant must be “shown” or “illustrated,” as part of the claim, drawings or photographs are required. 37 C.F.R. § 1.163(b)(5). Specifically:

(a) Plant patent drawings should be artistically and competently executed . . . . The drawing must disclose all the distinctive characteristics of the plant capable of visual representation.

(b) The drawings may be in color. The drawing must be in color if color is a distinguishing characteristic of the new variety. Two copies of color drawings or photographs must be submitted.

37 C.F.R. § 1.165. Plant patent specifications must also include a detailed botanical description of the claimed plant variety. 37 C.F.R. §§ 1.163(c)(9).

Additionally, plant patent specifications must include both the “Latin name of the genus and species of the plant claimed” as well as a “variety denomination,” or plant name. 37 C.F.R. §§ 1.163(c)(4)-(5). Today, the variety-designation is required by an international treaty, the International Convention for the Protection of New Varieties of Plants (generally known as the “UPOV Convention,” based on the convention’s French name, “Union pour la Protection des Obtentions Végétales”). MPEP § 1612. But plant variety designations were used even prior to the treaty. *See, e.g.*, U.S. Patent PP1 (giving the new climbing-rose variety the name “The New Dawn.”).

In practice, plant-patent variety denominations run the gamut from somewhat cold and clinical names, like a *Buxus* plant named “HER2010B04” (PP32,273), to less clinical names, like a *Phlox* plant named “Uptown Girl” (PP32,287) or a *Cannabis* plant named “Rainbow Gummeez” (PP31,918). But a plant patent applicant can’t pick just any name. In examining a plant patent application:

The examiner must evaluate the proposed denomination in light of UPOV Convention, Article 13. Basically, this Article requires that the proposed variety denomination not be identical with or confusingly similar to other names utilized in the United States or other UPOV member countries for the same or a closely related species. In addition, the proposed denomination must not mislead the average consumer as to the characteristics, value, or identity of the patented plant.

MPEP § 1612. If you've studied other areas of intellectual property law, do these sound like patent requirements to you? Or do they remind you of another intellectual property regime? *See generally* 15 U.S.C. § 1125.



What does it mean to “invent or discover” a new variety of plant? That’s the central question in the following case.

*In re Beineke*  
690 F.3d 1344 (Fed. Cir. 2012)

DYK, Circuit Judge.

Walter F. Beineke (“Beineke”) appeals from the decisions of the Board of Patent Appeals and Interferences (“Board”) affirming the examiner’s rejection of two plant patent applications under 35 U.S.C. § 161. We affirm.

*Background*

This appeal concerns two plant patent applications filed under section 161 by Beineke for new and distinct oak trees. In the fall of 1980, Beineke noticed two white oak trees (“AFTO–2” and “AFTO–3”) in the front yard of a home (not Beineke’s own residence) that appeared to display superior genetic traits as compared to other white oak trees, such as excellent timber quality and strong central stem tendency. When first identified by Beineke, AFTO–2 was approximately 118 years old and AFTO–3 was approximately 105 years old. . . . Beineke planted acorns from each of the trees and, over the next few years, observed the progeny trees. After observing the same superior traits in the progeny trees, Beineke asexually reproduced the trees and found that the reproductions ran true to the originally discovered trees and to each other in all respects. Having concluded that he had discovered two new and distinct varieties, Beineke applied for plant patents on both trees.

The examiner initially rejected both applications because . . . in his view the statute required that the trees not have been “found in an uncultivated state,” and the trees did not satisfy that requirement. In response, Beineke argued to the examiner that the land on which the trees were found was cultivated at the time of discovery, and that was sufficient to meet the requirements of section 161. The examiner then issued final rejections, finding that Beineke did not provide sufficient “factual support for the assertion that the instant trees were ‘in a cultivated state,’” such as “evidence of record describing cultivation of the claimed trees, e.g., planting of the trees, or maintenance, labor or attention given the claimed trees.”

## PLANTS

A divided Board affirmed the rejection of both applications.

...

### *Discussion*

It is settled that an applicant for a patent under section 161 must establish that the inventor has “recognized the plant’s uniqueness and difference,” and has “taken the step of asexual reproduction,” *Imazio Nursery, Inc. v. Dania Greenhouses*, 69 F.3d 1560, 1566 (Fed. Cir. 1995). The parties do not dispute these requirements. But in other respects, the parties offer quite different interpretations of the statute. Beineke argues that section 161 does not require that the alleged inventor (or other human) have played any role in the creation of the plant, and that finding a new variety of mature plant qualifies the plant for patent protection, assuming post-find cultivation, recognition, and asexual reproduction. The PTO, on the other hand, contends that no plant is patentable unless human activity played a role in the creation of the plant; in the PTO’s view, the statute protects only the work of plant breeders who create new varieties of plants either intentionally or by accident. As will be seen, we conclude that neither party is entirely correct, though the PTO’s reading of the statute is closer to the correct reading.

We consider first whether the trees are patentable . . . .

### I

As we discuss in detail below, under the 1930 Act, in addition to post-find cultivation, recognition, and asexual reproduction, two things were necessary for an applicant to obtain plant patent protection: (1) the plant must have been created in its inception by human activity, i.e., it must be the result of plant breeding or other agricultural or horticultural efforts; and (2) the plant must have been created by the “inventor,” i.e., the person seeking the patent must have contributed to the creation of the plant in addition to having appreciated its uniqueness and asexually reproduced it. Beineke has not demonstrated that he fulfills either of these requirements.

In 1930, Congress enacted the Plant Patent Act . . . . We must interpret the 1930 Act in light of the “contemporary legal context” in which it was enacted—that is, against the historical backdrop of the patent laws and the existing understanding of the language used in the act at the time.

Significantly, the 1930 Act crafted the plant patent provisions onto the pre-existing utility patent statute which included the “invents or discovers” requirement. The 1930 Act’s requirement that the applicant must “invent or discover” had an established meaning at the time. The “invents or discovers” language appeared in the first patent act in 1790 and appeared in all subsequent patent statutes. Prior to 1930, the Supreme Court in construing the “invents or discovers” language consistently emphasized that

the beneficiary of a patent *must be an inventor and he must have made a discovery*. . . . *It is not enough that a thing shall be new, in the sense that in the shape or form in which it is produced shall not have been before known, and that it shall be useful, but it must, under the constitution and the statute, amount to an invention or discovery.*

*Thompson v. Boisselier*, 114 U.S. 1, 11 (1885). In other words, the statute required some “exercise of the inventive faculty.” Other federal courts had also recognized that a patent could not be granted for “mere naked discovery.”

Prior to 1930, this view of the invention requirement suggested that plants, being products of nature, were not patentable at all. Judicial decisions reflected a “belief that plants, even those artificially bred, were products of nature for purposes of the patent law.” *Diamond v. Chakrabarty*, 447 U.S. 303, 311 (1980); *see also Imazio Nursery*, 69 F.3d at 1563. As recognized in *Chakrabarty*, at the time of the 1930 Act, decisions of the Commissioner of Patents also reflected this view. For example, an 1889 decision by the Commissioner of Patents in *Ex parte Latimer*, 1889 Dec. Comm’r Pat. 123, exemplified the then-prevailing understanding of the patentability of natural products. In rejecting a patent application on the fiber from pine needles, the Commissioner explained that

it cannot be said that the applicant in this case has made any discovery, or is entitled to patent the idea, or fact, rather, that fiber can be found in [pine needles] because the mere ascertaining of the character or quality of trees that grow in the forest and the construction of the woody fiber and tissue of which they are composed is not a patentable invention, recognized by the statute, any more than to find a new gem or jewel in the earth would entitle the discoverer to patent all gems which should be subsequently found. Otherwise it would be possible for an element or a principle to be secured by patent, and the patentee would obtain the right, to the exclusion of all other men, of securing by his new process from the trees of the forest . . . the fiber which nature has produced and which nature has intended to be equally for the use of all men. *The result would be that patents might be obtained upon the trees of the forest and the plants of the earth, which of course would be unreasonable and impossible.*

The Commissioner concluded by explaining that he was “not aware of any instance in which it has been held that a natural product is the subject of a patent, although it may have existed from creation without being discovered.”

Congress in 1930 sought to change the existing rule that no plants could be patented while preserving the rule that plants found in nature were not patentable. Plants created by plant breeders were viewed as an “exercise of the inventive faculty” and thus deserving of patent protection. In making this change to protect plant breeders, the 1930 Act also incorporated another fundamental [tenet] of patent law: that only the “inventor”

## PLANTS

could secure a patent application based on his own inventive efforts. All early patent statutes reflected the fact that a patent was only available to the true inventor. . . . The Supreme Court likewise emphasized the requirement that the inventor must be the one seeking the patent, and that “no one is entitled to a patent for that which he did not invent.” *Agawam Woolen Co. v. Jordan*, 74 U.S. 583, 602 (1868).

The legislative history of the 1930 Act confirms its limited scope. The Senate and House Committee Reports indicated that one of the primary purposes of the bill was to stimulate plant breeding by providing a financial incentive for plant breeders to engage in their work. Indeed, the reports speak mainly in terms of work to be done by “plant breeders” and “plant developers.” It is true that the reports do mention in multiple places “discovery” of plants but, as can be seen from various amendments to the bill that ultimately became the 1930 Plant Patent Act, such references refer to a plant breeder’s discovery resulting from his own work, and not a “chance find” or discovery of a plant explorer.

Although not explicitly stated in the statute, Congress was clear that only “cultivated sports, mutants, and hybrids were included in the bill.”<sup>6</sup>

<sup>6</sup> At the time of the 1930 Plant Patent Act, a “new and distinct variety” necessarily fell into one of three classes: sports, mutants, and hybrids. Sports result from bud variation and not seed variation. It occurs when a plant or portion of a plant suddenly assumes a new appearance or characteristic. Mutants result from seedling variation by self-pollenization. Hybrids result from seedlings of cross-pollenization of two different species. Because these sports, mutants, and hybrids will not reproduce true to type on their own, asexual reproduction is necessary to preserve them.

This reference to cultivation reemphasized Congress’s understanding that patent protection was available only for plants resulting from human creative efforts by the patent applicant, and not for found plants. . . .

. . .

This history demonstrates that the 1930 Act was not meant to include plants discovered by chance by plant explorers and the like.

In short, the provisions of the original 1930 Act, incorporated in the present plant patent statute, provided patent protection to only those plants (e.g., sports, mutants, and hybrids) that were created as a result of plant breeding or other agricultural and horticultural efforts and that were created by the inventor, that is, the one applying for the patent. Beineke meets neither of these requirements. Beineke does not argue that the oak trees were in any way the result of his creative efforts or indeed anyone’s creative

efforts, and thus they do not fall within the scope of those plants protected by the 1930 Act.

## II

Because Beineke does not meet the other requirements of section 161 . . . , we need not reach the question of what is meant by “found in an uncultivated state” —that is, we need not determine what level of human cultivation of the area in which a seedling was found at its inception is necessary to satisfy the statute. The Board correctly determined that the mature oak trees found by Beineke in the front yard of a home were not entitled to plant patent protection under section 161.

### Context & Application

1. Why is there a separate type of patent for plants? In *Beineke*, the court tells us that Congress believed that plants were excluded from § 101 as “products of nature.” But there was another reason—in 1930, “plants were not considered amenable to the written description requirement.” *Imazio Nursery, Inc. v. Dania Greenhouses*, 69 F.3d 1560, 1563 (Fed. Cir. 1995). Congress addressed this problem by relaxing the written description requirement as applied to plants. See 35 U.S.C. § 162 (“No plant patent shall be declared invalid for noncompliance with section 112 if the description is as complete as is reasonably possible.”).

2. How could plant breeders protect their research investments prior to the passage of the PPA? Reportedly, the creator of the “Golden Delicious” apple tree enclosed it “in an iron cage to keep persons from stealing shoots for the purpose of propagating the tree.” LEON H. AMDUR. PATENT FUNDAMENTALS 261 (1948). What are the costs and benefits of that form of plant protection?

3. What is the scope of a plant patent? 35 U.S.C. § 163 provides:

In the case of a plant patent, the grant shall include the right to exclude others from asexually reproducing the plant, and from using, offering for sale, or selling the plant so reproduced, or any of its parts, throughout the United States, or from importing the plant so reproduced, or any parts thereof, into the United States.

The Federal Circuit has construed this language to mean that, “for purposes of plant patent infringement, the patentee must prove that the alleged infringing plant is an asexual reproduction, that is, that it is the progeny of the patented plant.” *Imazio Nursery*, 69 F.3d at 1569. In doing so, the court rejected the patent owner’s argument that a single plant patent could cover “a range of plants.” *Id.* at 1567. Not only is a plant patent limited to a single plant; it is limited to physical appropriations of that plant. An independently-created plant with identical attributes would not infringe a plant patent. But a plant patent

## PLANTS

can be infringed even if the progeny has different superficial characteristics. How does this compare to the scope given to a utility patent? Why would anyone want such a narrow form of protection? As two commentators have explained:

The PPA . . . provided protection only for asexual means of reproduction, like grafting or budding. In other words, a breeder who successfully creates a novel and distinct apple tree has the sole right, under the corresponding plant patent, to propagate and commercialize the tree by taking cuttings from it and grafting them on to new rootstock. Although the law appears to provide relatively narrow protection, the main object of protection, fruit trees, nut trees, and roses, do not breed true-to-type. Therefore, the only way for a competitor to appropriate a new variety of apple, for example, is to steal a cutting from the new tree, which is precisely what the law penalizes.

Paul J. Heald & Susannah Chapman, *Veggie Tales: Pernicious Myths About Patents, Innovation, and Crop Diversity in the Twentieth Century*, 2012 U. ILL. L. REV. 1051, 1057 (2012).

4. In *Beineke*, the court leaves open the question of what it means for a plant to be “found in an uncultivated state.” See 35 U.S.C. § 161 (excluding such plants from patentability). How much work should a plant breeder have to do to take a plant from “uncultivated” to “cultivated”? For one view, see *Ex Parte Amy Iezzoni*, No. 2020-001008, 2020 WL 5039374, at \*2 (P.T.A.B. Aug. 20, 2020).

5. In *Beineke*, the court relies on § 101 patent precedent to interpret § 161. Why does it do that? And can this case teach us anything about what it means to “invent or discover” something in the utility patent context?

### B. Plant Variety Protection Act

Congress passed the Plant Variety Protection Act (PVPA) in 1970. The PVPA provides *sui generis* patent-like protection for “new,” “distinct,” “uniform,” and “stable” (“DUS”) plant varieties. 7 U.S.C. § 2402(a). As the Supreme Court has explained:

The developer of a novel variety obtains PVPA coverage by acquiring a certificate of protection from the [U.S. Department of Agriculture’s] Plant Variety Protection Office. See 7 U.S.C. §§ 2421, 2422, 2481–2483. This confers on the owner the exclusive right . . . to “exclude others from selling the variety, or offering it for sale, or reproducing it, or importing it, or exporting it, or using it in producing (as distinguished from developing) a hybrid or different variety therefrom.” § 2483.

*Asgrow Seed Co. v. Winterboer*, 513 U.S. 179, 181 (1995). A plant variety protection certificate (PVP) lasts 20 or 25 years from the date the certificate issues. See 7 U.S.C. § 2483(b) (granting a term of 20 years for most plants and 25 years for vines and trees).

To be clear, PVPs are not patents. They are not subject to the requirements of patentability, such as nonobviousness. And PVPs are granted by the U.S. Department of Agriculture, not the USPTO. But arguments about the PVPA frequently arise in plant patent cases. *See, e.g., Imazio Nursery*, 69 F.3d at 1567 (“Both parties argue[d] that the provisions of the Plant Variety Protection Act are relevant to a proper interpretation of the scope of protection afforded plant patents under the Plant Patent Act.”). We also see arguments about the PVPA in utility patent cases. *See, e.g., Diamond v. Chakrabarty*, 447 U.S. 303, 313–14 (1980). And appeals from cases involving PVPA claims are in the exclusive jurisdiction of the Federal Circuit. *See* 28 U.S.C. § 1295(a)(1). How might that affect how the PVPA and the other plant-protection statutes are interpreted?

*AGSouth Genetics, LLC v. Georgia Farm Services, LLC*  
22 F. Supp. 3d 1342 (M.D. Ga. 2014)

W. LOUIS SANDS, District Judge.

Presently pending before the Court is Defendant’s Post-Trial Motion for Judgment as a Matter of Law. For the following reasons, Defendant’s Post-Trial Motion for Judgment as a Matter of Law is DENIED.

*Background*

Following a six-day trial, a jury rendered a verdict finding Georgia Farm Services (“GFS”) liable for willful infringement of Plaintiffs’ Plant Variety Protection Act (“PVPA”) Certificate in violation of the PVPA. . . .

...

On November 29, 2013, Defendant filed its Post-Trial Motion for Judgment as a Matter of Law and Memorandum of Supporting Authorities. Therein, Defendant claims that it is entitled to judgment as a matter of law . . . .

*Analysis*

Defendant bases all of its arguments regarding infringement of the PVPA on its assertion that “the only set of 15 bags that the evidence could have allowed the jury to find infringing were the 15 bags sold to Plaintiffs’ private investigator, Zelotis Wofford.” Defendant claims that the evidence is undisputed that those bags were not used for actual propagation of the variety and therefore are not infringing under the plain language of 7 U.S.C. § 2541(d). Plaintiffs argue that there is no basis to conclude that the 15 bags that the jury found infringing were the bags that were sold to Mr. Wofford. Plaintiffs maintain, however, that, even if the infringing bags were those sold to Mr. Wofford, the PVPA does



## PLANTS

not require a showing of actual propagation. Instead, Plaintiffs assert that § 2541(d) only exempts actions taken with express consent of the owner of the variety.

...

7 U.S.C. § 2541(a), titled "Acts constituting infringement," enumerates various acts that, if taken by a person or entity in regard to a protected variety, constitute infringement of the rights of the holder of the applicable PVP certificate. Infringing acts are limited to acts that occur in the United States, "or in commerce which can be regulated by Congress or affecting such commerce," within the time period when the PVP certificate is valid and active, and only where the purported infringer acts without authority and with requisite notice of the protected nature of the variety. The prohibited acts are as follows:

- (1) sell or market the protected variety, or offer it or expose it for sale, deliver it, ship it, consign it, exchange it, or solicit an offer to buy it, or any other transfer of title or possession of it;
- (2) import the variety into, or export it from, the United States;
- (3) sexually multiply, or propagate by a tuber or a part of a tuber, the variety as a step in marketing (for growing purposes) the variety;
- (4) use the variety in producing (as distinguished from developing) a hybrid or different variety therefrom;
- (5) use seed which had been marked "Unauthorized Propagation Prohibited" or "Unauthorized Seed Multiplication Prohibited" or progeny thereof to propagate the variety;
- (6) dispense the variety to another, in a form which can be propagated, without notice as to being a protected variety under which it was received;
- (7) condition the variety for the purpose of propagation, except to the extent that the conditioning is related to the activities permitted under section 2543 of this title;
- (8) stock the variety for any of the purposes referred to in paragraphs (1) through (7);
- (9) perform any of the foregoing acts even in instances in which the variety is multiplied other than sexually, except in pursuance of a valid United States plant patent; or
- (10) instigate or actively induce performance of any of the foregoing acts

7 U.S.C. § 2541(a). “The PVPA gives the holder of a PVP Certificate rather broad exclusive rights.” However, subsection (d) provides language that arguably circumscribes the purview of the PVPA. That subsection provides:

It shall not be an infringement of the rights of the owner of a variety to perform any act concerning propagating material of any kind, or harvested material, including entire plants and parts of plants, of a protected variety that is sold or otherwise marketed with the consent of the owner in the United States, unless the act involves further propagation of the variety or involves an export of material of the variety, that enables the propagation of the variety, into a country that does not protect varieties of the plant genus or species to which the variety belongs, unless the exported material is for final consumption purposes.

7 U.S.C. § 2541(d). Defendant argues that subsection (d) exempts any act from the ambit of infringing acts under the PVPA unless there is evidence of actual propagation. In other words, Defendant reads subsection (d) to require that actual propagation of the variety occur before any of the enumerated actions in subsection (a) constitute infringement. Plaintiffs argue that subsection (d) “only applies when the seller is given express authority by the owner to sell or market a protected variety prior to commencing such sale or marketing.” In other words, Plaintiffs read subsection (d) to exempt only those actions that are taken with express authority of the owner of the protected variety.

The Court rejects both suggested readings of subsection (d). Defendant’s interpretation would greatly circumscribe infringing acts under the PVPA. For instance, a seed dealer could sell seeds to farmers without limitation and avoid PVPA liability as long as there is no evidence that those seeds were actually propagated. That conclusion would be contrary to the apparent intent of the sweeping scope of § 2541(a). For instance, § 2541(a)(8) makes the mere stocking of a variety for any purpose also enumerated in § 2541(a) an infringing act. It would be incongruous to assume that Congress intended to make the mere stocking of a protected variety an infringing act if actual propagation was required for infringement. Since Defendant’s reading of § 2541(d) would completely remove the mere stocking of a variety from the purview of § 2541(a), Defendant’s reading of § 2541(d) would render § 2541(a)(8) superfluous. . . . Because the Court “must strive to give effect to every word in the statutory text,” the Court rejects both Parties’ interpretations of § 2541(d).

In the Federal Circuit, the “first step in interpreting a statute is to determine whether the language at issue has a plain and unambiguous meaning with regard to the particular dispute in the case.” The PVPA and § 2541(d) are not models of clarity. As the Court reads the language, certain clauses could modify several other clauses and determining which clause modifies which cannot be ascertained without context. For instance, it is not immediately clear whether “in the United States” is intended to modify “of a protected

variety that is sold or otherwise marketed” or “with the consent of the owner.” As such, the Court finds that the statutory language is ambiguous and thus turns to the canons of statutory construction.

“Beyond the statute’s text, the ‘traditional tools of statutory construction’ include the statute’s structure, canons of statutory construction, and legislative history.” “When the statutory language is ambiguous, legislative history can be useful in determining Congressional intent.” In light of the various rules and canons of statutory construction, the Court reads 7 U.S.C. § 2541(d) to exclude from the ambit of infringing acts any act that does not involve further propagation of any material of a protected variety that is capable of being propagated and that has been placed into the stream of commerce in the United States by or with the participation and consent of the owner. Thus, once a variety is placed into the stream of commerce by the owner, § 2541(d) exempts acts taken in relation to that variety to the extent the acts do not involve propagation. Defendant proposes that “involves propagation” should be read to require actual propagation. Neither the statutory language nor any case cited by Defendant supports that reading. Instead, “involve” should be given its Merriam-Webster definition: “to have or include (someone or something) as a part of something.”

The Court’s reading of subsection (d) comports with the legislative history of the PVPA. When passed in 1970, the purpose of the PVPA was to “assure the developers of novel varieties of sexually reproduced plants of exclusive rights to sell, reproduce, import, or export such varieties, or use them in the production (as distinguished from the development) of hybrids or different varieties, for a period of 17 years.” H.P. Rep. No. 91–1605 (1970). Thus, the PVPA seeks to protect owners of varieties from the distribution of the variety for the purpose of production as distinguished from distribution for the purpose of development. Accordingly, it stands to reason that § 2451(d) would exempt any act that does not involve production—i.e. propagation. The Court is mindful, however, that defining “involve” too narrowly would eviscerate the intended purpose of the PVPA by removing from the PVPA’s ambit many instances where the protected variety was distributed for the purpose of production but actual propagation did not occur or could not be demonstrated.

In light of the referenced interpretation of § 2541(d), the Court finds that Defendant’s actions are not covered by the exemption at § 2541(d) because this case involved propagation. The evidence introduced at trial supports a finding that Defendant sold 320 bags of AGS 2000 to Edward Parker and that the seed from those bags were actually propagated, and thus involved propagation. Also, even if the jury relied solely on the transaction with Mr. Wofford, the evidence at trial showed that propagation was involved in that transaction. Mr. Wofford asked Mr. Wingate several questions regarding the various characteristics of the seeds and their crop-yielding potential, and Mr. Wingate

offered to sell Mr. Wofford various products to help the seeds grow. Further, Mr. Wingate admitted at trial that he assumed that the seeds were to be planted. Accordingly, the Court finds that Defendant's actions as to AGS 2000 "involved further propagation of the variety," and therefore do not fall within the exemption at § 2541(d).

### Context & Application

1. What can we learn from this case about the requirements of the PVPA? What can we learn about statutory interpretation more generally?

2. Why was the PVPA passed? In addition to "the purpose" discussed in *AGSouth*, "the PVPA was enacted partially in response to Western European nations' formation of the Paris Union in 1960, also known as the International Union for the Protection of New Varieties of Plants (UPOV)." Keith Aoki, *Seeds of Dispute: Intellectual-Property Rights and Agricultural Biodiversity*, 3 GOLDEN GATE U. ENVTL. L.J. 79, 98–99 (2009). The United States joined the UPOV in 1981. *Id.* at 99 n.98.

3. How are the protections provided by the PVPA similar to or different than those provided by plant patents? In what situations might someone prefer one form of protection to the other?

4. As enacted in 1970, the PVPA only protected sexually reproduced plants—i.e., those grown from seeds. *Imazio Nursery, Inc. v. Dania Greenhouses*, 69 F.3d 1560, 1567 (Fed. Cir. 1995). The Agricultural Improvement Act (also known as the "Farm Bill") of 2018 amended the PVPA to also cover asexually produced plants. See 7 U.S.C. § 2402(a). Why do you think Congress made this change?

5. The 2018 Farm Bill also legalized industrial hemp (*Cannabis sativa* L.). See Sean M. O'Connor & Erika Lietzan, *The Surprising Reach of FDA Regulation of Cannabis, Even After Descheduling*, 68 AM. U. L. REV. 823, 858 (2019) (noting that the Farm Bill "effectively defines hemp as *Cannabis sativa* with THC concentration of not more than 0.3 percent on a dry weight basis.") (citing Pub. L. No. 115-334 (2018)). Accordingly, the USDA began accepting PVP applications for hemp in April 2019. See Jocelyn Bosse, *Before The High Court: The Legal Systematics of Cannabis*, 29 GRIFFITH LAW REVIEW 1, 20–21 (2020). As of March 2021, the USDA had issued PVPs for hemp. See, e.g., TOLS Cherry Wine S-1, PVP Certificate No. 201900198 (issued June 24, 2020).

6. In *AGSouth*, the court mentions the concept of "requisite notice." In the PVPA, Congress prefaced the list of infringing actions with the following:

Except as otherwise provided in this subchapter, it shall be an infringement of the rights of the owner of a protected variety to perform without authority, any of the

## PLANTS

following acts in the United States . . . *after either the issue of the certificate or the distribution of a protected plant variety with the notice under section 2567 of this title:*

7 U.S.C. § 2541 (emphasis added). The PVPA further provides that:

Owners may give notice to the public by physically associating with or affixing to the container of seed of a variety or by fixing to the variety, a label containing either the words “*Unauthorized Propagation Prohibited*” or the words “*Unauthorized Seed Multiplication Prohibited*” and after the certificate issues, such additional words as “U.S. Protected Variety”. In the event the variety is distributed by authorization of the owner and is received by the infringer without such marking, no damages shall be recovered against such infringer by the owner in any action for infringement, unless the infringer has actual notice or knowledge that propagation is prohibited or that the variety is a protected variety, in which event damages may be recovered only for infringement occurring after such notice. As to both damages and injunction, a court shall have discretion to be lenient as to disposal of materials acquired in good faith by acts prior to such notice.

7 U.S.C. § 2567 (emphasis added). Does this mean that there is no cause of action under the PVPA without this notice? Or is this merely an inducement to provide notice?

7. The PVPA specifically prohibits certain types of misbranding. For example, “[u]se of the words ‘U.S. Protected Variety’ or any word or number importing that the material is a variety protected under certificate, when it is not” and “[u]se of either the phrase ‘Unauthorized Propagation Prohibited’ or ‘Unauthorized Seed Multiplication Prohibited’ or similar phrase without reasonable basis” are both prohibited. *See* 7 U.S.C. §§ 2568(a)(1), (3). As to the last point, “[a]ny reasonable basis expires one year after the first sale of the variety except as justified thereafter by a pending application or a certificate still in force.” *Id.* § 2568(a)(3). While we’re on the subject of branding, should a PVP owner be able to register its variety name as a trademark? *See In re Pennington Seed, Inc.*, 466 F.3d 1053, 1055 (Fed. Cir. 2006).

8. Unlike the PPA, the PVPA requires that “a viable sample of basic seed (including any propagating material) necessary for propagation of the variety . . . be deposited and replenished periodically in a public repository . . . .” *See* 7 U.S.C. § 2422(4). *See also* 85 Fed. Reg. 422 (2020) (delaying enforcement of the deposit requirement for asexually reproduced varieties until January 6, 2023). Those deposits must be submitted to the National Laboratory for Genetic Resource Preservation in Fort Collins, Colorado. These deposits are not made public until the PVP expires. How might this requirement affect the desirability of this form of protection?

## C. Utility Patents for Plants

In 1985, the USPTO's Board of Patent Appeals and Interferences (BPAI) held that plants could be the subject of utility patents. *See Ex Parte Hibberd*, 227 U.S.P.Q. (BNA) ¶ 443 (BPAI Sept. 24, 1985). But, of course, the USPTO does not have the final say on questions of patent law. Therefore, the status of utility patents for plants remained unclear until 2001, when the Supreme Court decided the case that follows.

*J.E.M. Ag Supply, Inc. v. Pioneer Hi-Bred Int'l, Inc.*  
534 U.S. 124 (2001)

Justice THOMAS delivered the opinion of the Court.

This case presents the question whether utility patents may be issued for plants under 35 U.S.C. § 101, or whether the Plant Variety Protection Act, 7 U.S.C. § 2321 *et seq.*, and the Plant Patent Act of 1930, 35 U.S.C. §§ 161–164, are the exclusive means of obtaining a federal statutory right to exclude others from reproducing, selling, or using plants or plant varieties. We hold that utility patents may be issued for plants.

## I

The United States Patent and Trademark Office (PTO) has issued some 1,800 utility patents for plants, plant parts, and seeds pursuant to 35 U.S.C. § 101. Seventeen of these patents are held by respondent Pioneer Hi-Bred International, Inc. (Pioneer). Pioneer's patents cover the manufacture, use, sale, and offer for sale of the company's inbred and hybrid corn seed products. . . .

. . .

Pioneer sells its patented hybrid seeds under a limited label license that provides: "License is granted solely to produce grain and/or forage." The license "does not extend to the use of seed from such crop or the progeny thereof for propagation or seed multiplication." It strictly prohibits "the use of such seed or the progeny thereof for propagation or seed multiplication or for production or development of a hybrid or different variety of seed."

Petitioner J.E.M. Ag Supply, Inc., doing business as Farm Advantage, Inc., purchased patented hybrid seeds from Pioneer in bags bearing this license agreement. Although not a licensed sales representative of Pioneer, Farm Advantage resold these bags. Pioneer subsequently brought a complaint for patent infringement against Farm Advantage and several other corporations . . . Pioneer alleged that Farm Advantage has "for a long-time

## PLANTS

past been and still is infringing one or more Pioneer patents by making, using, selling, or offering for sale corn seed of the hybrids in infringement of these patents-in-suit.”

Farm Advantage . . . argu[es] that patents that purport to confer protection for corn plants are invalid because sexually reproducing plants are not patentable subject matter within the scope of 35 U.S.C. § 101. Farm Advantage maintained that the Plant Patent Act of 1930 (PPA) and the Plant Variety Protection Act (PVPA) set forth the exclusive statutory means for the protection of plant life because these statutes are more specific than § 101, and thus each carves out subject matter from § 101 for special treatment.<sup>1</sup>

<sup>1</sup> Petitioners favor a holding that the PVPA is the only means of protecting these corn plants primarily because the PVPA’s coverage is generally less extensive and the hybrid seeds at issue do not have PVPA protection. Most notably, the PVPA provides exemptions for research and for farmers to save seed from their crops for replanting. Utility patents issued for plants do not contain such exemptions.

The District Court granted summary judgment to Pioneer. . . .

The United States Court of Appeals for the Federal Circuit affirmed . . . . We granted certiorari and now affirm.

## II

The question before us is whether utility patents may be issued for plants pursuant to 35 U.S.C. § 101. . . .

As this Court recognized over 20 years ago in *Chakrabarty*, the language of § 101 is extremely broad. “In choosing such expansive terms as ‘manufacture’ and ‘composition of matter,’ modified by the comprehensive ‘any,’ Congress plainly contemplated that the patent laws would be given wide scope.” . . .

. . .

Thus, in approaching the question presented by this case, we are mindful that this Court has already spoken clearly concerning the broad scope and applicability of § 101.

Several years after *Chakrabarty*, the PTO Board of Patent Appeals and Interferences held that plants were within the understood meaning of “manufacture” or “composition of matter” and therefore were within the subject matter of § 101. *In re Hibberd*, 227 USPQ 443, 444 (1985). It has been the unbroken practice of the PTO since that time to confer utility patents for plants. To obtain utility patent protection, a plant breeder must show that the plant he has developed is new, useful, and non-obvious. In addition, the plant must meet the specifications of § 112, which require a written description of the plant and a deposit of seed that is publicly accessible.

## CHAPTER 11

Petitioners do not allege that Pioneer’s patents are invalid for failure to meet the requirements for a utility patent. Nor do they dispute that plants otherwise fall within the terms of § 101’s broad language that includes “manufacture” or “composition of matter.” Rather, petitioners argue that the PPA and the PVPA provide the exclusive means of protecting new varieties of plants, and so awarding utility patents for plants upsets the scheme contemplated by Congress. We disagree. Considering the two plant specific statutes in turn, we find that neither forecloses utility patent coverage for plants.

### A

The 1930 PPA conferred patent protection to asexually reproduced plants. Significantly, nothing within either the original 1930 text of the statute or its recodified version in 1952 indicates that the PPA’s protection for asexually reproduced plants was intended to be exclusive.

Plants were first explicitly brought within the scope of patent protection in 1930 when the PPA included “plants” among the useful things subject to patents. Thus the 1930 PPA amended the general utility patent provision to provide:

Any person who has invented or discovered any new and useful art, machine, manufacture, or composition of matter, or any new and useful improvements thereof, or who has invented or discovered and asexually reproduced any distinct and new variety of plant, other than a tuber-propagated plant, not known or used by others in this country, before his invention or discovery thereof, may obtain a patent therefor.

Act of May 23, 1930, § 1, 46 Stat. 376.

This provision limited protection to the asexual reproduction of the plant. Asexual reproduction occurs by grafting, budding, or the like, and produces an offspring with a genetic combination identical to that of the single parent—essentially a clone.<sup>3</sup>

<sup>3</sup> By contrast, sexual reproduction occurs by seed and sometimes involves two different plants.

...

In 1952, Congress revised the patent statute and placed the plant patents into a separate chapter 15 of Title 35 entitled, “Patents for plants.” 35 U.S.C. §§ 161–164. This was merely a housekeeping measure that did nothing to change the substantive rights or requirements for a plant patent. A “plant patent” continued to provide only the exclusive right to asexually reproduce a protected plant, § 163, and the description requirement remained relaxed, § 162.<sup>5</sup>



## PLANTS

<sup>5</sup> Patents issued under § 161 are referred to as “plant patents,” which are distinguished from § 101 utility patents and § 171 design patents.

Plant patents under the PPA thus have very limited coverage and less stringent requirements than § 101 utility patents.

Importantly, chapter 15 nowhere states that plant patents are the exclusive means of granting intellectual property protection to plants. Although unable to point to any language that requires, or even suggests, that Congress intended the PPA’s protections to be exclusive, petitioners advance three reasons why the PPA should preclude assigning utility patents for plants. We find none of these arguments to be persuasive.

First, petitioners argue that plants were not covered by the general utility patent statute prior to 1930. In advancing this argument, petitioners overlook the state of patent law and plant breeding at the time of the PPA’s enactment. The Court in *Chakrabarty* explained the realities of patent law and plant breeding at the time the PPA was enacted: “Prior to 1930, two factors were thought to remove plants from patent protection. The first was the belief that plants, even those artificially bred, were products of nature for purposes of the patent law. The second obstacle to patent protection for plants was the fact that plants were thought not amenable to the ‘written description’ requirement of the patent law.” Congress addressed these concerns with the 1930 PPA, which recognized that the work of a plant breeder was a patentable invention and relaxed the written description requirement. The PPA thus gave patent protection to breeders who were previously unable to overcome the obstacles described in *Chakrabarty*.

This does not mean, however, that prior to 1930 plants could not have fallen within the subject matter of § 101. Rather, it illustrates only that in 1930 Congress *believed* that plants were not patentable under § 101, both because they were living things and because in practice they could not meet the stringent description requirement. Yet these premises were disproved over time. As this Court held in *Chakrabarty*, “the relevant distinction” for purposes of § 101 is not “between living and inanimate things, but between products of nature, whether living or not, and human-made inventions.” In addition, advances in biological knowledge and breeding expertise have allowed plant breeders to satisfy § 101’s demanding description requirement.

Whatever Congress may have believed about the state of patent law and the science of plant breeding in 1930, plants have always had the potential to fall within the general subject matter of § 101, which is a dynamic provision designed to encompass new and unforeseen inventions. . . .

Petitioners essentially ask us to deny utility patent protection for sexually reproduced plants because it was unforeseen in 1930 that such plants could receive protection under § 101. Denying patent protection under § 101 simply because such coverage was thought

technologically infeasible in 1930, however, would be inconsistent with the forward-looking perspective of the utility patent statute. As we noted in *Chakrabarty*, “Congress employed broad general language in drafting § 101 precisely because new types of inventions are often unforeseeable.”

Second, petitioners maintain that the PPA’s limitation to asexually reproduced plants would make no sense if Congress intended § 101 to authorize patents on plant varieties that were sexually reproduced. But this limitation once again merely reflects the reality of plant breeding in 1930. At that time, the primary means of reproducing bred plants true-to-type was through asexual reproduction. Congress thought that sexual reproduction through seeds was not a stable way to maintain desirable bred characteristics. Thus, it is hardly surprising that plant patents would protect only asexual reproduction, since this was the most reliable type of reproduction for preserving the desirable characteristics of breeding.

Furthermore, like other laws protecting intellectual property, the plant patent provision must be understood in its proper context. Until 1924, farmers received seed from the Government’s extensive free seed program that distributed millions of packages of seed annually. In 1930, seed companies were not primarily concerned with varietal protection, but were still trying to successfully commodify seeds. There was no need to protect seed breeding because there were few markets for seeds.

By contrast, nurseries at the time had successfully commercialized asexually reproduced fruit trees and flowers. These plants were regularly copied, draining profits from those who discovered or bred new varieties. Nurseries were the primary subjects of agricultural marketing and so it is not surprising that they were the specific focus of the PPA.

Moreover, seed companies at the time could not point to genuinely new varieties and lacked the scientific knowledge to engage in formal breeding that would increase agricultural productivity. In short, there is simply no evidence, let alone the overwhelming evidence needed to establish repeal by implication, that Congress, by specifically protecting asexually reproduced plants through the PPA, intended to preclude utility patent protection for sexually reproduced plants.

Third, petitioners argue that in 1952 Congress would not have moved plants out of the utility patent provision and into § 161 if it had intended § 101 to allow for protection of plants. Petitioners again rely on negative inference because they cannot point to any express indication that Congress intended § 161 to be the exclusive means of patenting plants. But this negative inference simply does not support carving out subject matter that otherwise fits comfortably within the expansive language of § 101, especially when § 101 can protect different attributes and has more stringent requirements than does § 161.

## PLANTS

This is especially true given that Congress in 1952 did nothing to change the substantive rights or requirements for obtaining a plant patent. Absent a clear intent to the contrary, we are loath to interpret what was essentially a housekeeping measure as an affirmative decision by Congress to deny sexually reproduced plants patent protection under § 101.

### B

By passing the PVPA in 1970, Congress specifically authorized limited patent-like protection for certain sexually reproduced plants. Petitioners therefore argue that this legislation evidences Congress' intent to deny broader § 101 utility patent protection for such plants. Petitioners' argument, however, is unavailing for two reasons. First, nowhere does the PVPA purport to provide the exclusive statutory means of protecting sexually reproduced plants. Second, the PVPA and § 101 can easily be reconciled. Because it is harder to qualify for a utility patent than for a Plant Variety Protection (PVP) certificate, it only makes sense that utility patents would confer a greater scope of protection.

### 1

The PVPA provides plant variety protection for: "The breeder of any sexually reproduced or tuber propagated plant variety (other than fungi or bacteria) who has so reproduced the variety." 7 U.S.C. § 2402(a).

Infringement of plant variety protection occurs, inter alia, if someone sells or markets the protected variety, sexually multiplies the variety as a step in marketing, uses the variety in producing a hybrid, or dispenses the variety without notice that the variety is protected.

...

The PVPA also contains exemptions for saving seed and for research. A farmer who legally purchases and plants a protected variety can save the seed from these plants for replanting on his own farm. *See* § 2543. In addition, a protected variety may be used for research. *See* 7 U.S.C. § 2544. The utility patent statute does not contain similar exemptions.

Thus, while the PVPA creates a statutory scheme that is comprehensive with respect to its particular protections and subject matter, giving limited protection to plant varieties that are new, distinct, uniform, and stable, § 2402(a), nowhere does it restrict the scope of patentable subject matter under § 101. With nothing in the statute to bolster their view that the PVPA provides the exclusive means for protecting sexually reproducing plants, petitioners rely on the legislative history of the PVPA. They argue that this history shows the PVPA was enacted because sexually reproducing plant varieties and their seeds were

not and had never been intended by Congress to be included within the classes of things patentable under Title 35.

The PVPA itself, however, contains no statement that PVP certificates were to be the exclusive means of protecting sexually reproducing plants. The relevant statements in the legislative history reveal nothing more than the limited view of plant breeding taken by some Members of Congress who believed that patent protection was unavailable for sexually reproduced plants. This view stems from a lack of awareness concerning scientific possibilities.

Furthermore, at the time the PVPA was enacted, the PTO had already issued numerous utility patents for hybrid plant processes. Many of these patents, especially since the 1950's, included claims on the products of the patented process, i.e., the hybrid plant itself. Such plants were protected as part of a hybrid process and not on their own. Nonetheless, these hybrids still enjoyed protection under § 101, which reaffirms that such material was within the scope of § 101.

### 3

Petitioners also suggest that even when statutes overlap and purport to protect the same commercially valuable attribute of a thing, such "dual protection" cannot exist. Yet this Court has not hesitated to give effect to two statutes that overlap, so long as each reaches some distinct cases. Here, while utility patents and PVP certificates do contain some similar protections, as discussed above, the overlap is only partial.

Moreover, this Court has allowed dual protection in other intellectual property cases. "Certainly the patent policy of encouraging invention is not disturbed by the existence of another form of incentive to invention. In this respect the two systems [trade secret protection and patents] are not and never would be in conflict." *Kewanee Oil [Co. v. Bicon Corp.]*, 416 U.S. 470, 484 (1974)]; *see also Mazer v. Stein*, 347 U.S. 201, 217 (1954) (the patentability of an object does not preclude the copyright of that object as a work of art). In this case, many plant varieties that are unable to satisfy the stringent requirements of § 101 might still qualify for the lesser protections afforded by the PVPA.

### III

We also note that the PTO has assigned utility patents for plants for at least 16 years and there has been no indication from either Congress or agencies with expertise that such coverage is inconsistent with the PVPA or the PPA. The Board of Patent Appeals and Interferences, which has specific expertise in issues of patent law, relied heavily on this Court's decision in *Chakrabarty* when it interpreted the subject matter of § 101 to include plants. *In re Hibberd*, 227 USPQ 443 (1985). This highly visible decision has led to the issuance of some 1,800 utility patents for plants. Moreover, the PTO, which administers

## PLANTS

§ 101 as well as the PPA, recognizes and regularly issues utility patents for plants. In addition, the Department of Agriculture’s Plant Variety Protection Office acknowledges the existence of utility patents for plants.

In the face of these developments, Congress has not only failed to pass legislation indicating that it disagrees with the PTO’s interpretation of § 101; it has even recognized the availability of utility patents for plants. In a 1999 amendment to 35 U.S.C. § 119, which concerns the right of priority for patent rights, Congress provided: “Applications for plant breeder’s rights filed in a WTO member country shall have the same effect for the purpose of the right of priority as applications for patents, subject to the same conditions and requirements of this section as apply to applications for patents.” 35 U.S.C. § 119(f). Crucially, § 119(f) is part of the general provisions of Title 35, not the specific chapter of the PPA, which suggests a recognition on the part of Congress that plants are patentable under § 101.

## IV

For these reasons, we hold that newly developed plant breeds fall within the terms of § 101, and that neither the PPA nor the PVPA limits the scope of § 101’s coverage. As in *Chakrabarty*, we decline to narrow the reach of § 101 where Congress has given us no indication that it intends this result. Accordingly, we affirm the judgment of the Court of Appeals.

It is so ordered.

Justice BREYER, with whom Justice STEVENS joins, dissenting.

The question before us is whether the words “manufacture” or “composition of matter” contained in the utility patent statute, 35 U.S.C. § 101 (Utility Patent Statute), cover plants that also fall within the scope of two more specific statutes, the Plant Patent Act of 1930 (PPA), and the Plant Variety Protection Act (PVPA). I believe that the words “manufacture” or “composition of matter” do not cover these plants. That is because Congress intended the two more specific statutes to exclude patent protection under the Utility Patent Statute for the plants to which the more specific Acts directly refer. And, as the Court implicitly recognizes, this Court neither considered nor decided this question in *Diamond v. Chakrabarty*, 447 U.S. 303 (1980). Consequently, I dissent.

## I

Respondent and the Government claim that *Chakrabarty* controls the outcome in this case. This is incorrect, for *Chakrabarty* said nothing about the specific issue before us. *Chakrabarty*, in considering the scope of the Utility Patent Statute’s language “manufacture, or composition of matter,” 35 U.S.C. § 101, asked whether those words included such living things as bacteria—a substance to which neither of the two specific

plant Acts refers. The Court held that the Utility Patent Statute language included a “new” bacterium because it was “a nonnaturally occurring manufacture or composition of matter” that was “not nature’s handiwork.” It quoted language from a congressional Committee Report indicating that “Congress intended statutory subject matter to ‘include anything under the sun that is made by man.’” But it nowhere said or implied that this Utility Patent Statute language also includes the very subject matter with which the two specific statutes deal, namely, plants. Whether a bacterium technically speaking is, or is not, a plant, the Court considered it a “life form,” and not the kind of “plant” that the two specific statutes had in mind.

The Court did consider a complicated argument that sought indirectly to relate the two specific plant statutes to the issue before it. That argument went roughly as follows: (1) Congress enacted two special statutes related to plants. (2) Even though those two statutes do not cover bacteria, the fact that Congress enacted them shows that Congress thought the Utility Patent Statute’s language (“manufacture, or composition of matter”) did not cover any living thing, including bacteria. (3) Congress consequently must have intended the two special Acts to provide exclusive protection for all forms of “life” whether they do, or do not, count as the kinds of “plants” to which the specific statutes refer.

The Court, in reply, wrote that Congress, when enacting the specific statutes, might have (wrongly) believed that the Utility Patent Statute did not apply to plants, probably because Congress thought that plants were “natural products,” not human products. It added that Congress also might have believed that it was too difficult for plant inventors to meet patent law’s ordinary “written description” requirement. In addition, the Court pointed out that the relevant distinction between unpatentable and patentable subject matter was not between living and inanimate things, but rather between products of nature and human-made inventions. As such, the bacteria at issue were patentable because they were products of human invention. And the Court concluded that “nothing” in Congress’ decision to exclude bacteria from the PVPA supported “petitioner’s position,” namely, that Congress intended no utility patent protection for any living thing.

Neither this refutation nor the argument itself decides the question here. That question is not about general coverage for matters that the special statutes do not mention (namely, nonplant life forms such as bacteria). It is about general coverage for matters to which the special plant statutes do refer (namely, plants). *Chakrabarty* neither asked, nor answered, this latter question, the question now before us. And nothing in the Court’s opinion indicates the contrary.

## PLANTS

### II

The critical question, as I have said, is whether the two specific plant statutes embody a legislative intent to deny coverage under the Utility Patent Statute to those plants to which the specific plant statutes refer. In my view, the first of these statutes, the PPA, reveals precisely that intent. And nothing in the later history of either the Utility Patent Statute or the PVPA suggests the contrary.

As initially enacted in 1930, the PPA began by amending the Utility Patent Statute to read as follows:

Any person who has invented or discovered any new and useful art, machine, manufacture, or composition of matter, or any new and useful improvements thereof, *or who has invented or discovered and asexually reproduced any distinct and new variety of plant, other than a tuber-propagated plant* may obtain a patent therefor.”

Rev. Stat. § 4886, as amended by Act of May 23, 1930, § 1, 46 Stat. 376 (language added by the PPA italicized).

...

... [T]he PPA permits patenting of new and distinct varieties of (1) plants that breeders primarily reproduce through grafts (say, apple trees), (2) plants that breeders primarily reproduce through seeds (say, corn), and (3) plants that reproduce both ways (say, violets). But, because that statute left plant buyers free to keep, to reproduce, and to sell seeds, the statute likely proved helpful only to those in the first category. Both the PPA’s legislative history and the earliest patents granted under the Act fully support this interpretation.

Given these characteristics, the PPA is incompatible with the claim that the Utility Patent Statute’s language (“manufacture, or composition of matter”) also covers plants. To see why that is so, simply imagine a plant breeder who, in 1931, sought to patent a new, distinct variety of plant that he invented but which he has never been able to reproduce through grafting, i.e., asexually. Because he could not reproduce it through grafting, he could not patent it under the more specific terms of the PPA. Could he nonetheless patent it under the more general Utility Patent Statute language “manufacture, or composition of matter?”

Assume the court that tried to answer that question was prescient, i.e., that it knew that this Court, in *Chakrabarty*, would say that the Utility Patent Statute language (“manufacture,” or “composition of matter”) in principle might cover “anything under the sun,” including bacteria. Such a prescient court would have said that the Utility Patent Statute did cover plants had the case reached it in 1929, before Congress enacted the more specific 1930 law. But how could any court decide the case similarly in 1931 after

enactment of the 1930 amendment? To do so would virtually nullify the PPA's primary condition—that the breeder have reproduced the new characteristic through a graft—reading it out of the Act. Moreover, since the Utility Patent Statute would cover, and thereby forbid, reproduction by seed, such a holding would also have read out of the statute the PPA's more limited list of exclusive rights. Consequently, even a prescient court would have had to say, as of 1931, that the 1930 Plant Patent Act had, in amending the Utility Patent Statute, placed the subject matter of the PPA—namely, plants—outside the scope of the words “manufacture, or composition of matter.”

Nothing that occurred after 1930 changes this conclusion. In 1952, the Utility Patent Statute was recodified, and the PPA language I have quoted was given its own separate place in the Code. As Pioneer itself concedes, that change was not “substantive.” Indeed, as recodified the PPA still allows a breeder to obtain a patent when he “invents or discovers and asexually reproduces *any* distinct and new variety of plant,” 35 U.S.C. § 161 (1994 ed.), but it only allows the patent holder to “exclude others from *asexually* reproducing the plant or selling or using the plant so reproduced,” § 163.

Nor does the enactment of the Plant Variety Protection Act of 1970 change the conclusion. The PVPA proved necessary because plant breeders became capable of creating new and distinct varieties of certain crops, corn, for example, that were valuable only when reproduced through seeds—a form of reproduction that the earlier Act freely permitted. Just prior to its enactment a special Presidential Commission, noting the special problems that plant protection raised and favoring the development of a totally new plant protection scheme, had recommended that “all provisions in the patent statute for plant patents be deleted.” Instead Congress kept the PPA while adding the PVPA. The PVPA gave patent-like protection (for 20 years) to plants reproduced by seed, and it excluded the PPA's requirement that a breeder have “asexually reproduced” the plant. It imposed certain specific requirements. And it provided the breeder with an exclusive right to sell, offer to sell, reproduce, import, or export the variety, including the seeds.

At the same time, the PVPA created two important exceptions. The first provided that a farmer who plants his fields with a protected plant “shall not infringe any right hereunder” by saving the seeds and planting them in future years. § 2543. The second permitted “use and reproduction of a protected variety for plant breeding or other bona fide research.” § 2544.

Nothing in the history, language, or purpose of the 1970 statute suggests an intent to reintroduce into the scope of the general words “manufacture, or composition of matter” the subject matter that the PPA had removed, namely, plants. To the contrary, any such reintroduction would make meaningless the two exceptions—for planting and for research—that Congress wrote into that Act. . . .



## PLANTS

### Context & Application

1. If plants can be protected by utility patents, do we still need plant patents? Or PVPs? Who might benefit from each different form of plant protection?

2. In *Bowman v. Monsanto Co.*, the Supreme Court considered “whether a farmer who buys [utility] patented seeds may reproduce them through planting and harvesting without the patent holder’s permission” and held that they could not. 569 U.S. 278, 280 (2013). According to the Court, this followed from *J.E.M.*:

[W]e explained that only a patent holder (not a certificate holder) could prohibit “a farmer who legally purchases and plants” a protected seed from saving harvested seed “for replanting.” That statement is inconsistent with applying exhaustion to protect conduct like Bowman’s. If a sale cut off the right to control a patented seed’s progeny then (contrary to *J.E.M.*) the patentee could not prevent the buyer from saving harvested seed. Indeed, the patentee could not stop the buyer from selling such seed, which even a PVP certificate owner (who, recall, is supposed to have fewer rights) can usually accomplish. Those limitations would turn upside-down the statutory scheme *J.E.M.* described.

Do you agree? How does the *Bowman* holding affect your view of the desirability (from an individual and a system perspective) of utility patent protection for plants?

3. In *J.E.M.*, the majority states that Congress was simply wrong to believe, in 1930, that plants were not patentable under the statutory subject matter provision that is now codified at 35 U.S.C. § 101. Do you agree?

4. In *J.E.M.*, the majority also states that in the 16 years since the USPTO started issuing utility patents for plants, “there ha[d] been no indication from either Congress or agencies with expertise that such coverage is inconsistent with the PVPA or the PPA.” Would you expect the USPTO to speak up against its own position? Or for members of Congress to speak up on this issue? If not, what should we make (or not make) of this silence?

5. What about plants that are illegal under federal law? “Marihuana”—which is defined as “all parts of the plant *Cannabis sativa* L., whether growing or not; the seeds thereof; the resin extracted from any part of such plant; and every compound, manufacture, salt, derivative, mixture, or preparation of such plant, its seeds or resin” — is a Schedule I drug under the Controlled Substances Act (CSA). 21 U.S.C. §§ 812, 802(16)(A). See also *id.* 802(16)(B) (“The term ‘marihuana’ does not include—(i) hemp, as defined in section 1639o of Title 7 . . . .”); 7 U.S.C.A. § 1639o (“The term ‘hemp’ means the plant *Cannabis sativa* L. and any part of that plant, including the seeds thereof and all derivatives, extracts, cannabinoids, isomers, acids, salts, and salts of isomers, whether

growing or not, with a delta-9 tetrahydrocannabinol concentration of not more than 0.3 percent on a dry weight basis.”). This means it is illegal under federal law “for any person knowingly or intentionally . . . [to] manufacture, distribute, or dispense, or possess with intent to manufacture, distribute, or dispense” most cannabis products. 21 U.S.C. § 841(a). Nevertheless, the USPTO will issue patents for new varieties of cannabis and other cannabis-related inventions. *See, e.g.,* Breeding, Production, Processing and Use of Specialty Cannabis, U.S. Patent 9,095,554 (filed Mar. 17, 2014); *Cannabis Plant Named ‘Ecuadorian Sativa,’* U.S. Patent PP27,475 (filed Mar. 13, 2010); Cannabis Storing Container with Individual Tear Off Lids, U.S. Patent D798,739 (filed Apr. 7, 2016). By contrast, the USPTO will not register trademarks for use in connection with cannabis products that are illegal under the CSA:

[I]f the record indicates that the mark itself or the goods or services violate federal law, an inquiry or refusal must be made. For example, evidence indicating that the identified goods or services involve the sale or transportation of a controlled substance or drug paraphernalia in violation of the Controlled Substances Act . . . would be a basis for issuing an inquiry or refusal. . . . Note that, regardless of state law, marijuana, marijuana extracts, and the psychoactive component THC remain Schedule I controlled substances under federal law and are subject to the CSA’s prohibitions. These prohibitions apply with equal force to the distribution and dispensing of medical marijuana.

TRADEMARK MANUAL OF EXAMINING PROCEDURE § 907 (Oct. 2018) (citations omitted). Does this disparate treatment make sense? If not, which approach—protection or nonprotection—is better, as a policy matter? Does (or should) it matter that some uses of cannabis are not legal in various states?

Some courts have refused to enforce Lanham Act claims related to cannabis products. *See, e.g., Shulman v. Kaplan*, No. 2020 WL 7094063, at \*3 (C.D. Cal. Oct. 29, 2020) (“[B]ecause any alleged use of the Iron Triangle trademark was on cannabis products which are illegal under federal law, Plaintiffs cannot state a claim for violation of the Lanham Act.”). How, if at all, would these cases affect how you would counsel a client who was interested in obtaining a cannabis-related patent?

6. The USPTO allows a utility patent applicant to deposit biological material to help satisfy the written description requirement of 35 U.S.C. § 112. *See* 37 C.F.R. §§ 1.802, 1.808. And, as noted in *J.E.M.*, these deposits must be made available to the public. What would you do if a client wanted a patent for a new variety of *Cannabis*? Hint: The United States is a party to a treaty (the Budapest Treaty on the International Recognition of the Deposit of Microorganisms for the Purpose of Patent Procedures) that allows applicants to file biological matter—including, but not limited to microorganisms—in depositories in other member countries’ depositories.

## 12. DESIGNS

Unlike utility patents, which protect how things *work*, design patents protect how things *look*. See MPEP §1502.01. The statutory subject matter provision for design patents is 35 U.S.C. § 171. *In re Finch*, 535 F.2d 70, 71–72 (C.C.P.A. 1976). Section 171(a) provides:

Whoever invents any new, original and ornamental design for an article of manufacture may obtain a patent therefor, subject to the conditions and requirements of this title.

In accordance with this statutory language, “design patents are granted only for a design applied to an article of manufacture, and not a design *per se* . . . .” *Curver Luxembourg, SARL v. Home Expressions Inc.*, 938 F.3d 1334, 1340 (Fed. Cir. 2019).

What types of designs might be applied to an article of manufacture? There are three longstanding types of patentable designs:

- (1) A design for “surface ornamentation applied to an article”;
- (2) A design for “the configuration or shape of an article”; or
- (3) A design for the combination of both.

See U.S. DEPT OF COMMERCE, PATENT & TRADEMARK OFFICE, MANUAL OF PATENT EXAMINING PROCEDURE § 1504.01 (9th ed. Jan. 2018) (“MPEP”). These three types of patentable designs—surface designs, configuration designs, and combination designs—can be traced all the way back to the Supreme Court’s first design patent decision, *Gorham v. White*. See 81 U.S. 511, 525 (1871). Today, applicants can obtain design patents for any of these types of designs, or any part (or parts) thereof. See *In re Zahn*, 617 F.2d 261 (C.C.P.A. 1980). The USPTO has also interpreted the statute to allow applicants to claim designs that “encompass multiple articles or multiple parts within that article.” MPEP § 1504.01(b) (citing *Ex parte Gibson*, 20 USPQ 249 (Bd. App. 1933)).

Section 171(b) states that “[t]he provisions of this title relating to patents for inventions shall apply to patents for designs, except as otherwise provided.” So what is “otherwise provided”? Sections 171-173 provide specific rules that apply only to design patents—specifically, § 172 provides only six months priority for international applications and § 173 sets the term of a design patent as “15 years from the date of grant.” Section 289 provides a special remedy that is only available for certain acts of design patent infringement. Otherwise, the statutory provisions we’ve studied in connection with utility patents also apply to design patents. So, for example, a patentable design must be novel

and nonobvious. 35 U.S.C. §§ 102, 103. And a design patent must satisfy the requirements of § 112. However, the application of these sections and the tests used to analyze a design's compliance with them are quite different. This sometimes strikes those who've studied only utility patents as odd or even troubling. But design patents cover fundamentally different types of inventions and use an entirely different claiming system; under these circumstances, it would be odd if the statutory requirements *weren't* applied differently. Principles or practices developed with only utility patents in mind may or may not make sense for design patents and there is no reason why such principles or practices necessarily need to be imported into the design patent regime.

This chapter will start by exploring the scope of design patents, including how they're claimed. It will then discuss how the requirements of § 102 and § 103 have been interpreted and applied in the context of designs. Next, we'll cover the statutory requirement of ornamentality. Finally, we'll look at how § 112 has been applied to designs, and how that affects priority claims.

## A. Scope

Before diving into the validity doctrines, it's important to understand the scope of a design patent. So we'll start with how designs are claimed and then look at the test for design patent infringement.

### 1. Claiming

Design patent claims are very different than utility patent claims. A design patent can only have one claim and that "claim shall be in formal terms to the ornamental design for the article (specifying name) as shown, or as shown and described." 37 C.F.R. § 1.153(a). "The title of the design must designate the particular article," *id.*, and "the title and claim must correspond," MPEP § 1503.01(I).

How is a design "shown and described"? The applicant must submit drawings or photographs, including "a sufficient number of views to constitute a complete disclosure of the appearance of the design." 37 C.F.R. § 1.152. *See also* MPEP § 1503.02 (noting that photographs are also allowed). Color can also be claimed as part of a design, either by using color drawings or photographs or by using certain color shading conventions. *Id.*

For line drawings, anything shown in full lines is part of the claimed design. Applicant are also allowed to use broken lines in their design patent drawings. One word of warning: The rules about how and when applicants can use broken lines have changed over time, so be careful when looking at older design patents. Today:

## DESIGNS

The two most common uses of broken lines are to disclose the environment related to the claimed design and to define the bounds of the claim. Structure that is not part of the claimed design, but is considered necessary to show the environment in which the design is associated, may be represented in the drawing by broken lines. This includes any portion of an article in which the design is embodied, or applied to, that is not considered part of the claimed design. *See In re Zahn*, 617 F.2d 261 (CCPA 1980).

MPEP § 1503.02. Accordingly, an applicant might use broken lines to show how a claimed design might look in use, as in this drawing from a design patent that claims a design for a “Litter Box”:

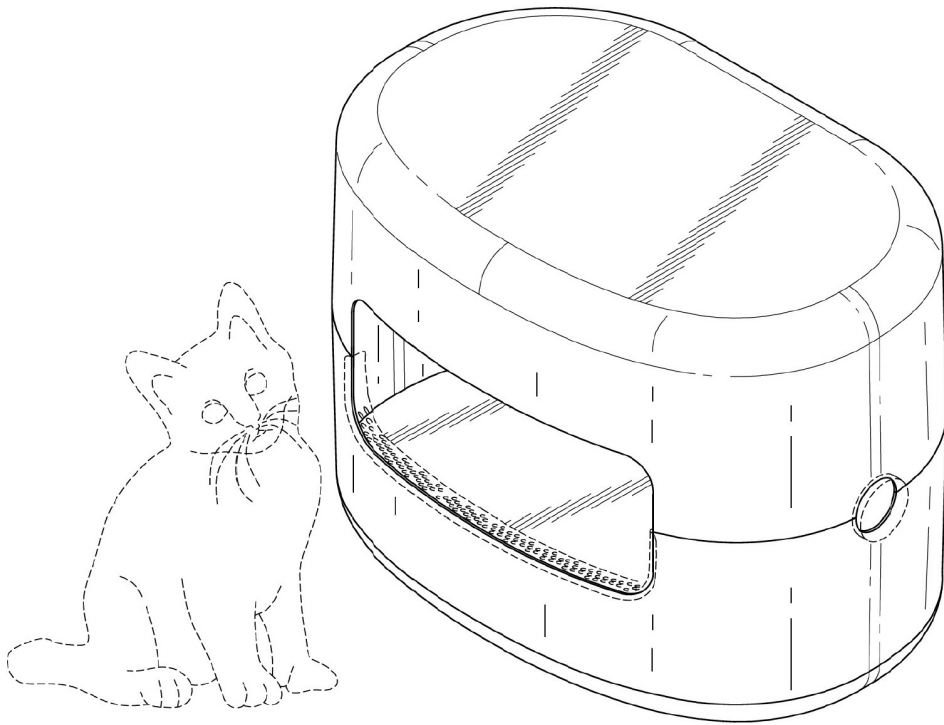

U.S. Patent D816,281, fig. 1 (issued Apr . 24 , 2018). The cat is shown in broken lines and, therefore, is not a part of the claimed design. (If you look closely, you can see some other details of the litter box are also disclaimed.)

## CHAPTER 12

Broken lines can also be used to disclaim parts of an article's shape or surface ornamentation. Consider, for example, this illustration from a design patent that claims a design for a "Pressed Shredded Potato Product":

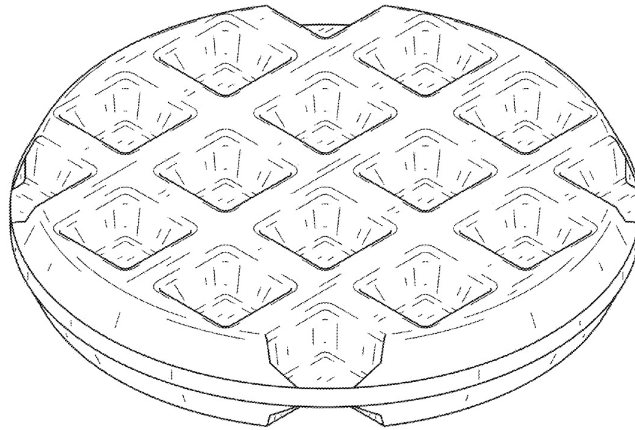

U.S. Patent No. D857,332, fig. 7 (issued Aug. 27 , 2019). The entire shape is shown in solid lines; therefore, the claim covers the entire shape. Compare that drawing to this one, from a design patent that was issued to the same patentee:

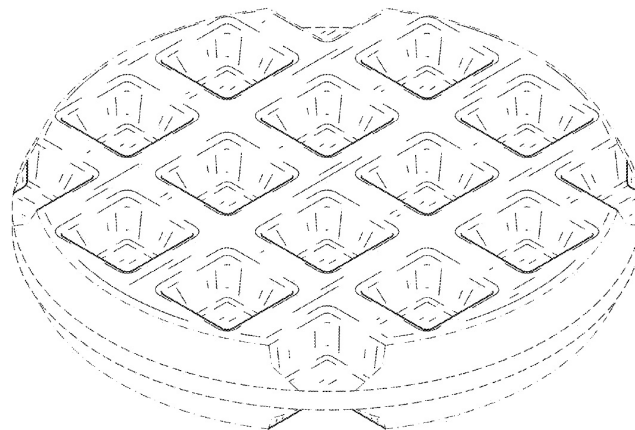

U.S. Patent D884,309 fig. 7 (issued May 19 , 2020). Why would an applicant want to disclaim part of a design? They do it to increase the scope of the design patent. As we'll see below, a design patent is infringed when an accused product looks the same as the *claimed* design. If the claim only covers part of an article's shape or surface ornamentation, then only the corresponding part of the accused product has to look the same. So this claim could be infringed by a pressed, shredded potato product that was round or square or any shape—as long as the dimple pattern (the part shown in solid lines) looks the same.

## DESIGNS

Broken lines can also be used to show unclaimed boundaries: “Applicant may choose to define the bounds of a claimed design with broken lines when the boundary does not exist in reality in the article embodying the design. It would be understood that the claimed design extends to the boundary but does not include the boundary.” MPEP § 1503.02. These boundary lines are often (though not always) depicted using dot-dash lines, while environmental and disclaimer lines are often depicted using plain dashed lines. Here is an example of a drawing, from a design patent that claims a design for “Footwear,” that uses both dashed disclaimer lines and dot-dash boundary lines:



U.S. Patent D787,798, fig. 1 (issued May 30, 2017). Why would someone want to draft a claim like this? Is it a “design *for* an article of manufacture”? See 35 U.S.C. § 171(a).

Who examines design patent claims? Design patent examiners are not drawn from the general USPTO examiner corps. Instead, the USPTO hires people with backgrounds in design—people who majored (or have the equivalent experience) in fields like industrial design, architecture, graphic design, and fine arts—as design patent examiners. But you still have to have a technical background (i.e., be a member of the “patent bar”) to prosecute design patents for other people or to be lead counsel in a design patent proceeding before the PTAB. Does that make sense? For one argument for change, see Christopher Buccafusco & Jeanne C. Curtis, *The Design Patent Bar: An Occupational Licensing Failure*, 37 CARDOZO ARTS & ENT. L.J. 263 (2019).

## 2. Infringement

Section 271 applies to design patents. It is an infringement to make, use, sell, offer to sell, or import a patented design (or to do any of the other things specified in § 271). But how do we know if someone has made or sold a patented design? The rules that have been developed to evaluate utility patent infringement don't work for design patents because the form of the claims and the types of protected inventions are so different. Indeed, ever since the Supreme Court's first design patent case, *Gorham v. White*, courts have recognized that different infringement rules are needed for this different type of invention.



The next case, *Gorham Co. v. White*, involved U.S. Patent D1,440, issued in 1861 for a design for a "Fork and Spoon Handle." Here is a representative drawing from that patent:

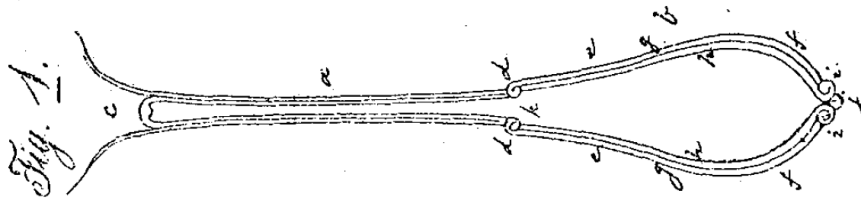

The lower court held that:

A patent for a design, like a patent for an improvement in machinery, must be for the means of producing a certain result or appearance, and not for the result or appearance itself. The plaintiffs' patent is for their described means of producing a certain appearance in the completed handle. Even if the same appearance is produced by another design, if the means used in such other design to produce the appearance are substantially different from the means used in the prior patented design to produce such appearance, the later design is not an infringement of the patented one.

10 F. Cas. 827, 830 (C.C.S.D.N.Y. 1870). The patent owner appealed to the Supreme Court (which at that time, heard direct appeals in patent cases).



*Gorham Co. v. White*  
81 U.S. 511 (1871)

Mr. Justice STRONG delivered the opinion of the court.

The sole question is one of fact. Has there been an infringement? Are the designs used by the defendant substantially the same as that owned by the complainants? To answer these questions correctly, it is indispensable to understand what constitutes identity of design, and what amounts to infringement?

The acts of Congress which authorize the grant of patents for designs were plainly intended to give encouragement to the decorative arts. They contemplate not so much utility as appearance, and that, not an abstract impression, or picture, but an aspect given to those objects mentioned in the acts. It is a new and original design for a manufacture, whether of metal or other material; a new and original design for a bust, statue, bas relief, or composition in alto or basso relievo; a new or original impression or ornament to be placed on any article of manufacture; a new and original design for the printing of woollen, silk, cotton, or other fabrics; a new and useful pattern, print, or picture, to be either worked into, or on, any article of manufacture; or a new and original shape or configuration of any article of manufacture—it is one or all of these that the law has in view. And the thing invented or produced, for which a patent is given, is that which gives a peculiar or distinctive appearance to the manufacture, or article to which it may be applied, or to which it gives form. The law manifestly contemplates that giving certain new and original appearances to a manufactured article may enhance its salable value, may enlarge the demand for it, and may be a meritorious service to the public. It therefore proposes to secure for a limited time to the ingenious producer of those appearances the advantages flowing from them. Manifestly the mode in which those appearances are produced has very little, if anything, to do with giving increased salableness to the article. It is the appearance itself which attracts attention and calls out favor or dislike. It is the appearance itself, therefore, no matter by what agency caused, that constitutes mainly, if not entirely, the contribution to the public which the law deems worthy of recompense. The appearance may be the result of peculiarity of configuration, or of ornament alone, or of both conjointly, but, in whatever way produced, it is the new thing, or product, which the patent law regards. To speak of the invention as a combination or process, or to treat it as such, is to overlook its peculiarities. As the acts of Congress embrace only designs applied, or to be applied, they must refer to finished products of invention rather than to the process of finishing them, or to the agencies by which they are developed. A patent for a product is a distinct thing from a patent for the elements entering into it, or for the ingredients of which it is composed, or for the combination that causes it. We do not say that in determining whether two designs are substantially the same, differences in the

lines, the configuration, or the modes by which the aspects they exhibit are not to be considered; but we think the controlling consideration is the resultant effect. . . .

We are now prepared to inquire what is the true test of identity of design. Plainly, it must be sameness of appearance, and mere difference of lines in the drawing or sketch, a greater or smaller number of lines, or slight variances in configuration, if sufficient to change the effect upon the eye, will not destroy the substantial identity. An engraving which has many lines may present to the eye the same picture, and to the mind the same idea or conception as another with much fewer lines. The design, however, would be the same. So a pattern for a carpet, or a print may be made up of wreaths of flowers arranged in a particular manner. Another carpet may have similar wreaths, arranged in a like manner, so that none but very acute observers could detect a difference. Yet in the wreaths upon one there may be fewer flowers, and the wreaths may be placed at wider distances from each other. Surely in such a case the designs are alike. The same conception was in the mind of the designer, and to that conception he gave expression.

If, then, identity of appearance, or sameness of effect upon the eye, is the main test of substantial identity of design, the only remaining question upon this part of the case is, whether it is essential that the appearance should be the same to the eye of an expert. The court below was of opinion that the test of a patent for a design is not the eye of an ordinary observer. The learned judge thought there could be no infringement unless there was 'substantial identity' 'in view of the observation of a person versed in designs in the particular trade in question—of a person engaged in the manufacture or sale of articles containing such designs—of a person accustomed to compare such designs one with another, and who sees and examines the articles containing them side by side.' There must, he thought, be a comparison of the features which make up the two designs. With this we cannot concur. Such a test would destroy all the protection which the act of Congress intended to give. There never could be piracy of a patented design, for human ingenuity has never yet produced a design, in all its details, exactly like another, so like, that an expert could not distinguish them. No counterfeit bank note is so identical in appearance with the true that an experienced artist cannot discern a difference. It is said an engraver distinguishes impressions made by the same plate. Experts, therefore, are not the persons to be deceived. Much less than that which would be substantial identity in their eyes would be undistinguishable in the eyes of men generally, of observers of ordinary acuteness, bringing to the examination of the article upon which the design has been placed that degree of observation which men of ordinary intelligence give. It is persons of the latter class who are the principal purchasers of the articles to which designs have given novel appearances, and if they are misled, and induced to purchase what is not the article they supposed it to be, if, for example, they are led to purchase forks or spoons, deceived by an apparent resemblance into the belief that they bear the 'cottage'

design, and, therefore, are the production of the holders of the Gorham, Thurber, and Dexter patent, when in fact they are not, the patentees are injured, and that advantage of a market which the patent was granted to secure is destroyed. The purpose of the law must be effected if possible; but, plainly, it cannot be if, while the general appearance of the design is preserved, minor differences of detail in the manner in which the appearance is produced, observable by experts, but not noticed by ordinary observers, by those who buy and use, are sufficient to relieve an imitating design from condemnation as an infringement.

We hold, therefore, that if, in the eye of an ordinary observer, giving such attention as a purchaser usually gives, two designs are substantially the same, if the resemblance is such as to deceive such an observer, inducing him to purchase one supposing it to be the other, the first one patented is infringed by the other.

### Context & Application

1. What does *Gorham* tell us about the purpose or purposes of design patent law? Do the goals identified by the Supreme Court seem like good goals for the system?

2. That there are two major issues decided in *Gorham*: (1) What is the test for identity (infringement) of a design?; and (2) From whose point of view is this inquiry conducted? What was the Court's answer to each question?

3. The most-quoted line from *Gorham*—“We hold, therefore, that if, in the eye of an ordinary observer, giving such attention as a purchaser usually gives, two designs are substantially the same, if the resemblance is such as to deceive such an observer, inducing him to purchase one supposing it to be the other, the first one patented is infringed by the other”—may strike contemporary readers as setting forth a trademark-like “likelihood of confusion” test. But that is not how the test was originally understood nor how it is understood today. *Unette Corp. v. Unit Pack Co.*, 785 F.2d 1026, 1027 (Fed. Cir. 1986) (answering the question of “whether ‘likelihood of confusion’ is a factor to be determined under the *Gorham* test for infringement of a design patent” in the negative). *See also Braun Inc. v. Dynamics Corp. of Am.*, 975 F.2d 815, 820 (Fed. Cir. 1992) (“Design patent infringement does not concern itself with the broad issue of consumer behavior in the marketplace.”). Read in the context of the case as a whole, *Gorham* clearly sets forth a test of visual similarity. That most-quoted line tells us *how* similar the designs must be—so similar that an ordinary observer would mistake one for the other. *See, e.g., Goodyear Tire & Rubber Co. v. Hercules Tire & Rubber Co.*, 162 F.3d 1113, 1118 (Fed. Cir. 1998), *abrogated on other grounds by Egyptian Goddess, Inc. v. Swisa, Inc.*, 543 F.3d 665 (Fed. Cir. 2008) (“Infringement of a design patent requires that *the designs have the same general visual appearance*, such that it is likely that the purchaser would be deceived into confusing the

design of the accused article with the patented design.”) (emphasis added); HECTOR T. FENTON, *THE LAW OF PATENTS FOR DESIGNS* 129 (1889) (“The general rule for the determination of the question of infringement of design patents was enunciated by the Supreme Court, in *Gorham v. White*, to be *similarity of general appearance* to the eye of average observers.”) (emphasis added).

4. As you can tell from *Gorham*, the design patent statutory subject matter provision used to look different. Back then, Congress defined design patentable subject matter in a long list of protectable designs. Congress enacted the current language—*i.e.*, what is now found in § 171(a)—in 1902. What, if anything, should we make of this language change?

*Egyptian Goddess, Inc. v. Swisa, Inc.*  
543 F.3d 665 (Fed. Cir. 2008) (*en banc*)

BRYSON, Circuit Judge.

We granted rehearing *en banc* in this design patent case to address the appropriate legal standard to be used in assessing claims of design patent infringement.

Appellant Egyptian Goddess, Inc., (“EGI”) brought this action . . . alleging that Swisa, Inc., and Dror Swisa (collectively, “Swisa”) had infringed EGI’s U.S. Design Patent No. 467,389 (“the ‘389 patent”). The patent claimed a design for a nail buffer, consisting of a rectangular, hollow tube having a generally square cross-section and featuring buffer surfaces on three of its four sides. Swisa’s accused product consists of a rectangular, hollow tube having a square cross-section, but featuring buffer surfaces on all four of its sides.

The district court first issued an order construing the claim of the ‘389 patent. In so doing, the district court sought to describe in words the design set forth in Figure 1 of the patent, which is depicted below:

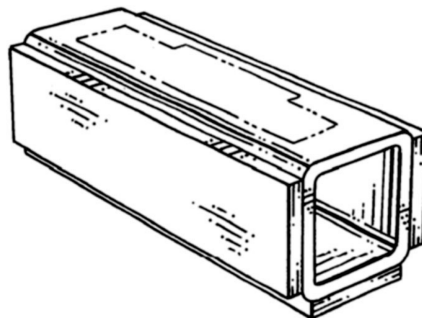

Upon study of the claimed design, the court described it as follows:

## DESIGNS

A hollow tubular frame of generally square cross section, where the square has sides of length  $S$ , the frame has a length of approximately  $3S$ , and the frame has a thickness of approximately  $T = 0.1S$ ; the corners of the cross section are rounded, with the outer corner of the cross section rounded on a 90 degree radius of approximately  $1.25T$ , and the inner corner of the cross section rounded on a 90 degree radius of approximately  $0.25T$ ; and with rectangular abrasive pads of thickness  $T$  affixed to three of the sides of the frame, covering the flat portion of the sides while leaving the curved radius uncovered, with the fourth side of the frame bare.

...

Swisa . . . moved for summary judgment of noninfringement. The district court granted the motion. . . .

...

EGI appealed, and a panel of this court affirmed.

...

This court granted rehearing *en banc* and asked the parties to address several questions, including whether the “point of novelty” test should continue to be used as a test for infringement of a design patent . . . and whether district courts should perform formal claim construction in design patent cases.

### I

The starting point for any discussion of the law of design patents is the Supreme Court’s decision in *Gorham Co. v. White*, 81 U.S. 511 (1871). That case involved a design patent for the handles of tablespoons and forks. In its analysis of claim infringement, the Court stated that the test of identity of design “must be sameness of appearance, and mere difference of lines in the drawing or sketch or slight variances in configuration will not destroy the substantial identity.” Identity of appearance, the Court explained, or “sameness of effect upon the eye, is the main test of substantial identity of design”; the two need not be the same “to the eye of an expert,” because if that were the test, “there never could be piracy of a patented design, for human ingenuity has never yet produced a design, in all its details, exactly like another, so like, that an expert could not distinguish them.”

The *Gorham* Court then set forth the test that has been cited in many subsequent cases: “If, in the eye of an ordinary observer, giving such attention as a purchaser usually gives, two designs are substantially the same, if the resemblance is such as to deceive such an observer, inducing him to purchase one supposing it to be the other, the first one patented is infringed by the other.” In the case before it, the Court concluded that “whatever

differences there may be between the plaintiffs' design and those of the defendant in details of ornament, they are still the same in general appearance and effect, so much alike that in the market and with purchasers they would pass for the same thing—so much alike that even persons in the trade would be in danger of being deceived.”

Since the decision in *Gorham*, the test articulated by the Court in that case has been referred to as the “ordinary observer” test and has been recognized by lower courts, including both of this court’s predecessors, as the proper standard for determining design patent infringement. However, in a series of cases tracing their origins to *Litton Systems, Inc. v. Whirlpool Corp.*, 728 F.2d 1423 (Fed. Cir. 1984), this court has held that proof of similarity under the ordinary observer test is not enough to establish design patent infringement. Rather, the court has stated that the accused design must also appropriate the novelty of the claimed design in order to be deemed infringing. The court in *Litton Systems* wrote as follows:

For a design patent to be infringed no matter how similar two items look, “the accused device must appropriate the novelty in the patented device which distinguishes it from the prior art.” That is, even though the court compares two items through the eyes of the ordinary observer, it must nevertheless, to find infringement, attribute their similarity to the novelty which distinguishes the patented device from the prior art.

After identifying the combination of features in the design that it considered novel, the court in *Litton Systems* held that the accused design had none of those features and therefore did not infringe.

In a number of cases decided after *Litton Systems*, this court has interpreted the language quoted above to require that the test for design patent infringement consider both the perspective of the ordinary observer and the particular novelty in the claimed design.

The extent to which the point of novelty test has been a separate test has not always been clear in this court’s case law. In cases decided shortly after *Litton*, the court described the ordinary observer test and the point of novelty test as “conjunctive.” It has not been until much more recently that this court has described the ordinary observer and point of novelty tests as “two distinct tests” and has stated that “the merger of the point of novelty test and the ordinary observer test is legal error.”

## II

As noted, this court has cited *Litton Systems* for the proposition that the point of novelty test is separate from the ordinary observer test and requires the patentee to point out the point of novelty in the claimed design that has been appropriated by the accused

design. We think, however, that *Litton* and the predecessor cases on which it relied are more properly read as applying a version of the ordinary observer test in which the ordinary observer is deemed to view the differences between the patented design and the accused product in the context of the prior art. When the differences between the claimed and accused design are viewed in light of the prior art, the attention of the hypothetical ordinary observer will be drawn to those aspects of the claimed design that differ from the prior art. And when the claimed design is close to the prior art designs, small differences between the accused design and the claimed design are likely to be important to the eye of the hypothetical ordinary observer. . . .

...

Not only is this approach consistent with the precedents discussed above, but it makes sense as a matter of logic as well. Particularly in close cases, it can be difficult to answer the question whether one thing is like another without being given a frame of reference. The context in which the claimed and accused designs are compared, i.e., the background prior art, provides such a frame of reference and is therefore often useful in the process of comparison. Where the frame of reference consists of numerous similar prior art designs, those designs can highlight the distinctions between the claimed design and the accused design as viewed by the ordinary observer.

...

. . . Our rejection of the point of novelty test does not mean, of course, that the differences between the claimed design and prior art designs are irrelevant. To the contrary, examining the novel features of the claimed design can be an important component of the comparison of the claimed design with the accused design and the prior art. But the comparison of the designs, including the examination of any novel features, must be conducted as part of the ordinary observer test, not as part of a separate test focusing on particular points of novelty that are designated only in the course of litigation.

On the basis of the foregoing analysis, we hold that the “point of novelty” test should no longer be used in the analysis of a claim of design patent infringement. . . . [I]n accordance with *Gorham* and subsequent decisions, we hold that the “ordinary observer” test should be the sole test for determining whether a design patent has been infringed. Under that test, as this court has sometimes described it, infringement will not be found unless the accused article “embodies the patented design or any colorable imitation thereof.”

In some instances, the claimed design and the accused design will be sufficiently distinct that it will be clear without more that the patentee has not met its burden of proving the two designs would appear “substantially the same” to the ordinary observer . . . . In other instances, when the claimed and accused designs are not plainly dissimilar,

resolution of the question whether the ordinary observer would consider the two designs to be substantially the same will benefit from a comparison of the claimed and accused designs with the prior art, as in many of the cases discussed above and in the case at bar. Where there are many examples of similar prior art designs . . . differences between the claimed and accused designs that might not be noticeable in the abstract can become significant to the hypothetical ordinary observer who is conversant with the prior art.

. . . [I]f the accused infringer elects to rely on the comparison prior art as part of its defense against the claim of infringement, the burden of production of that prior art is on the accused infringer. . . . [I]t makes sense to impose the burden of production as to any comparison prior art on the accused infringer. The accused infringer is the party with the motivation to point out close prior art, and in particular to call to the court's attention the prior art that an ordinary observer is most likely to regard as highlighting the differences between the claimed and accused design. Regardless of whether the accused infringer elects to present prior art that it considers pertinent to the comparison between the claimed and accused design, however, the patentee bears the ultimate burden of proof to demonstrate infringement by a preponderance of the evidence. . . .

### III

One of the issues raised by this court in its order granting *en banc* review was whether trial courts should conduct claim construction in design patent cases. While this court has held that trial courts have a duty to conduct claim construction in design patent cases, as in utility patent cases, the court has not prescribed any particular form that the claim construction must take. To the contrary, the court has recognized that design patents "typically are claimed as shown in drawings," and that claim construction "is adapted accordingly." For that reason, this court has not required that the trial court attempt to provide a detailed verbal description of the claimed design, as is typically done in the case of utility patents.

As the Supreme Court has recognized, a design is better represented by an illustration "than it could be by any description and a description would probably not be intelligible without the illustration." *Dobson v. Dornan*, 118 U.S. 10, 14 (1886). The Patent and Trademark Office has made the same observation. Manual of Patent Examining Procedure § 1503.01 (8th ed. 2006) ("As a rule the illustration in the drawing views is its own best description."). Given the recognized difficulties entailed in trying to describe a design in words, the preferable course ordinarily will be for a district court not to attempt to "construe" a design patent claim by providing a detailed verbal description of the claimed design.

With that said, it is important to emphasize that a district court's decision regarding the level of detail to be used in describing the claimed design is a matter within the court's



## DESIGNS

discretion, and absent a showing of prejudice, the court's decision to issue a relatively detailed claim construction will not be reversible error. At the same time, it should be clear that the court is not obligated to issue a detailed verbal description of the design if it does not regard verbal elaboration as necessary or helpful. In addition, in deciding whether to attempt a verbal description of the claimed design, the court should recognize the risks entailed in such a description, such as the risk of placing undue emphasis on particular features of the design and the risk that a finder of fact will focus on each individual described feature in the verbal description rather than on the design as a whole. In this case, for example, the district court came up with a detailed verbal description of the claimed design. We see no inaccuracy in the court's description, and neither party has pointed to any prejudice resulting from the court's interpretation. Yet it is not clear that the considerable effort needed to fashion the verbal description contributed enough to the process of analyzing the case to justify the effort.

While it may be unwise to attempt a full description of the claimed design, a court may find it helpful to point out, either for a jury or in the case of a bench trial by way of describing the court's own analysis, various features of the claimed design as they relate to the accused design and the prior art. . . .

Apart from attempting to provide a verbal description of the design, a trial court can usefully guide the finder of fact by addressing a number of other issues that bear on the scope of the claim. Those include such matters as describing the role of particular conventions in design patent drafting, such as the role of broken lines, *see* 37 C.F.R. § 1.152; assessing and describing the effect of any representations that may have been made in the course of the prosecution history; and distinguishing between those features of the claimed design that are ornamental and those that are purely functional, *see OddzOn Prods., Inc. v. Just Toys, Inc.*, 122 F.3d 1396, 1405 (Fed. Cir. 1997).

Providing an appropriate measure of guidance to a jury without crossing the line and unduly invading the jury's fact-finding process is a task that trial courts are very much accustomed to, and any attempt by an appellate court to guide that process in detail is likely to do more harm than good. We therefore leave the question of verbal characterization of the claimed designs to the discretion of trial judges, with the proviso that as a general matter, those courts should not treat the process of claim construction as requiring a detailed verbal description of the claimed design, as would typically be true in the case of utility patents.

## IV

We now turn to the facts of this case. It is agreed that the general shape of the accused nail buffer at issue in this case is the same as that of the patented buffer design. The difference between the two is that the accused buffer has raised buffing pads on all four

sides, while the patented buffer has buffing pads on only three sides. The two closest prior art nail buffers before the court were the Falley nail buffer, which has a solid, rectangular cross section with slightly raised buffers on all sides, and the Nailco patent, which shows a nail buffer design having a triangular shape and a hollow cross section, and in which raised buffing pads are located on all three sides. The four nail buffers are pictured below:

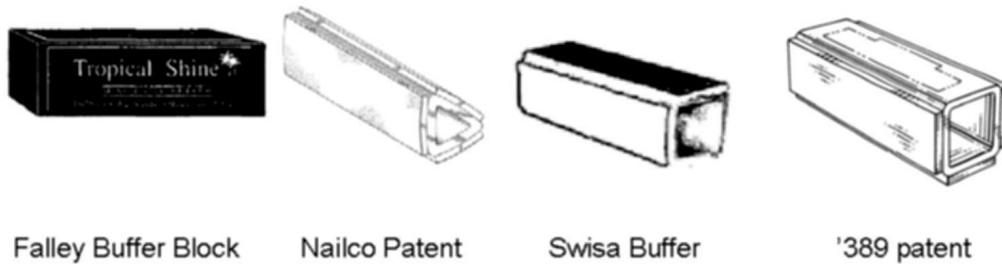

The question before this court under the standard we have set forth above is whether an ordinary observer, familiar with the prior art Falley and Nailco designs, would be deceived into believing the Swisa buffer is the same as the patented buffer. EGI argues that such an observer would notice a difference between the prior art and the '389 patent, consisting of “the hollow tube that is square in cross section and that has raised pads with exposed gaps at the corners.” . . .

. . .

In light of the similarity of the prior art buffers to the accused buffer, we conclude that no reasonable fact-finder could find that EGI met its burden of showing, by a preponderance of the evidence, that an ordinary observer, taking into account the prior art, would believe the accused design to be the same as the patented design. In concluding that a reasonable fact-finder could not find infringement in this case, we reach the same conclusion that the district court reached, and for many of the same reasons. . . .

. . . The panel wrote: “The Swisa buffers have raised, abrasive pads on all four sides. When considering the prior art in the nail buffer field, this difference between the accused design and the patented design cannot be considered minor.” That point captures the essence of the rationale of our decision today, even though the panel decision employed a different analytical approach. For the foregoing reasons, we sustain the district court’s entry of summary judgment of no infringement . . . .

### Context & Application

1. *Egyptian Goddess* creates a two-part framework for analyzing claims of design patent infringement. First, the claimed design and the accused design must be compared.

## DESIGNS





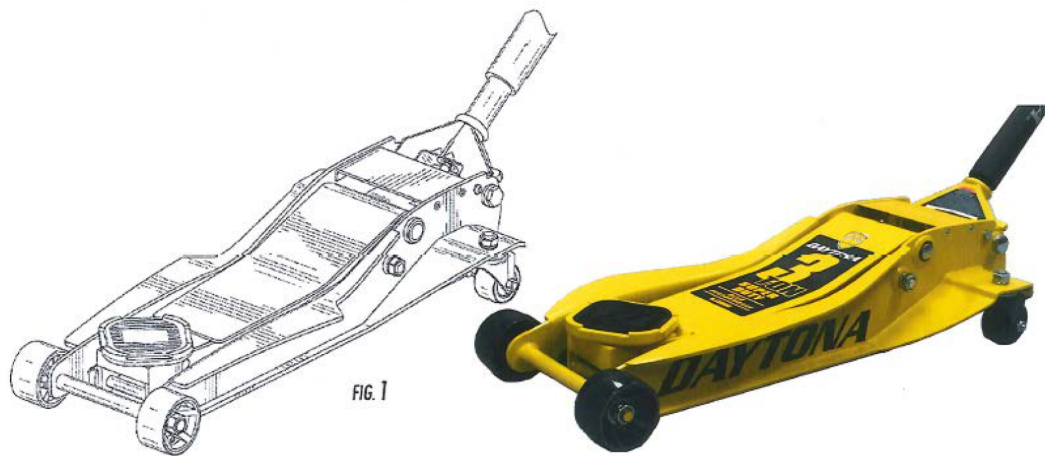

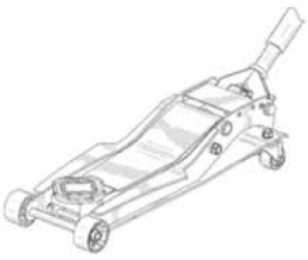

If the designs are “sufficiently distinct that it will be clear without more that the patentee has not met its burden of proving the two designs would appear ‘substantially the same’ to the ordinary observer,” 543 F.3d 665, 678 (Fed. Cir. 2008), then there is no infringement. We might think of this first step as setting forth the “presumptive scope” of a design patent. Second, if the designs are “not plainly dissimilar,” the prior art may be used to narrow the presumptive scope of the patent. *See id.*

Note that this is a one-way ratchet—the prior art can only be used to narrow the presumptive scope of a design patent, not to expand it. *See Ethicon Endo-Surgery, Inc. v. Covidien, Inc.*, 796 F.3d 1312, 1337 (Fed. Cir. 2015) (“[C]omparing the claimed and accused designs with the prior art is beneficial *only* when the claimed and accused designs are not plainly dissimilar”) (emphasis added). How does this work in practice? An example might help. Here is the asserted design patent and accused product from *Snap-On Inc. v. Harbor Freight Tools USA, Inc.*, No. 2:16-cv-01265, 2017 WL 44833 (E.D. Wis. Jan. 4, 2017):

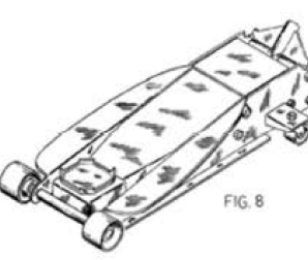

Remember, everything shown in solid lines is part of the claimed design. So this design patent covers the entire shape of the product. Considered in the abstract, these designs might not seem plainly dissimilar. But when viewed in light of the prior art, a number of visual differences between the claimed design (top left) and accused design (bottom right) become apparent:

CHAPTER 12

		
<b>D'612 (2014)</b>	<b>D646,453 (2010)</b>	<b>Performance Tool W1642 2-Ton (2011)</b>
		
<b>Mac Tools JSA350LR (2014)</b>	<b>Pittsburgh 3-Ton Low Profile (2013)</b>	<b>HeinWarner 3-Ton (2006)</b>
		
<b>Jackco 66300B 3-Ton (2010)</b>	<b>Arcan LL-35 (2004)</b>	<b>D388,926 (1996)</b>
		
<b>Cornwell Tools Blue Monster (2011)</b>	<b>Performance Tool W1627 3.5-Ton (2012)</b>	<b>Daytona (2016)</b>

*See id.* at \*4. The court concluded that the patent owner was not likely to succeed on the merits and denied the patent owner's motion for a preliminary injunction.

## DESIGNS

2. Notice that, in design patent law, there is no distinction between literal infringement and infringement by equivalents. There's just *Egyptian Goddess*. Does that makes sense, given how design patents are claimed? Do the reasons that support the doctrine of equivalents for utility patents apply to designs? See, e.g. *Festo Corp. v. Shoketsu Kinzoku Kogyo Kabushiki Co.*, 535 U.S. 722, 734 (2002) ("The doctrine of equivalents is premised on language's inability to capture the essence of innovation . . .").

3. The Supreme Court and the Federal Circuit say that infringement must be analyzed from the perspective of an "ordinary observer." Who is the ordinary observer? In *Egyptian Goddess*, the court uses the term as a synonym for "purchaser" more specifically, a "purchaser familiar with the prior art." Additionally, as *Egyptian Goddess* makes clear, the ordinary observer is a hypothetical person, like the reasonable person in torts. So patent owners cannot prove similarity by going out and surveying purchasers. Instead, as a practical matter, the factfinder (the judge or the jury) sits in for the ordinary observer:

Nothing in *Gorham* suggests that, in finding design patent infringement, a trier of fact may not as a matter of law rely exclusively or primarily on a visual comparison of the patented design, as well as the device that embodies the design, and the accused device's design. It is true that in *Gorham*, the U.S. Supreme Court found design patent infringement and in doing so relied in part on empirical and testimonial evidence that ordinary observers would be likely to mistake one product for another. However, in *Gorham*, the Supreme Court did not state, or suggest, that a panel of jurors was anything other than a panel of ordinary observers capable of making a factual determination as to whether they would be deceived by an accused device's design similarity to a patented design. Simply put, a jury, comprised of a sampling of ordinary observers, does not necessarily require empirical evidence as to whether ordinary observers would be deceived by an accused device's design.

*Braun Inc. v. Dynamics Corp. of Am.*, 975 F.2d 815, 821–22 (Fed. Cir. 1992). Therefore, if there is prior art that could narrow the presumptive scope of the design patent at *Egyptian Goddess* step two, the accused infringer needs to be sure to get any such prior art admitted into evidence.

4. One major issue in *Egyptian Goddess* was claim construction. What does the *en banc* Federal Circuit allow district courts to do with respect to claim construction? What does it advise them to do?

5. One thing that *Egyptian Goddess* says district judges can do in claim construction is "distinguish[] between those features of the claimed design that are ornamental and those that are purely functional," citing *OddzOn Prods., Inc. v. Just Toys, Inc.*, 122 F.3d 1396, 1405

## CHAPTER 12

(Fed. Cir. 1997). Would making such distinctions actually be helpful to the jury under the test articulated in *Egyptian Goddess*? Would you expect “functional” features (however that term is defined) to already exist in the prior art? We already know that design patents protect how something looks, not what it does. So even if “functional” (however that term is defined) features are included in the claim scope, they would not protect any function *qua* function. What useful purpose—if any—could this OddzOn-style claim construction serve, post-*Egyptian Goddess*?

6. How close is too close under *Egyptian Goddess*? In *Lin v. Belkin International, Inc.*, the plaintiff alleged that this USB cable infringed this design patent:

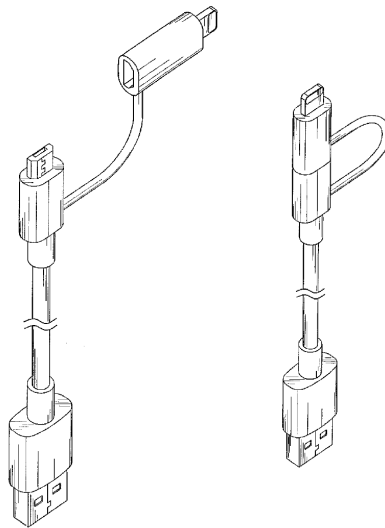

The court granted summary judgment of noninfringement. Based on its own visual review, the court found that the designs were so “sufficiently distinct and plainly

## DESIGNS

dissimilar . . . that no reasonable jury could find the two designs to be substantially the same.” *Lin v. Belkin Int’l, Inc.*, No. 8:16-cv-00628, 2017 WL 2903261, at \*6 (C.D. Cal. May 12, 2017).

In *Wallace v. Ideavillage Products Corp.*, the plaintiff alleged that this spinning brush infringed this design patent:

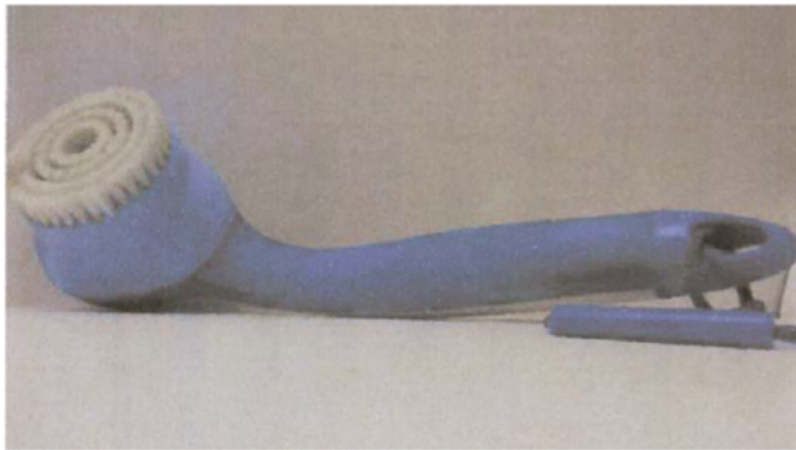
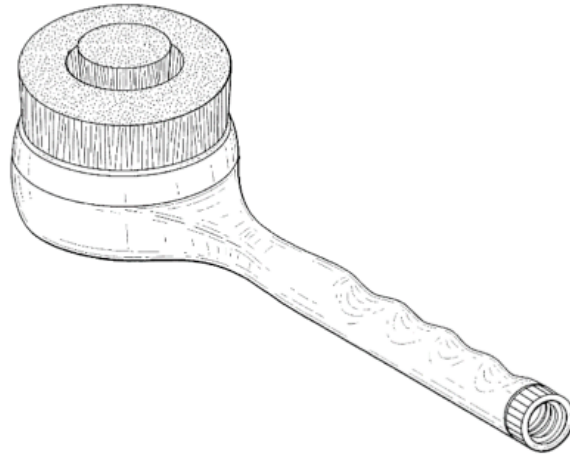

The district court granted the defendant’s motion for summary judgment of noninfringement, concluding, upon visual review, that the designs were “sufficiently distinct” and that the plaintiff could not, “as a matter of law, prove that the designs appear substantially the same.” *Wallace v. Ideavillage Prods. Corp.*, No. 2:06-cv-05673, 2014 WL 4637216, at \*4 (D.N.J. Sept. 15, 2014), *aff’d*, 640 F. App’x 970, 972 (Fed. Cir. 2016).

## CHAPTER 12

In *Performance Designed Products LLC v. Mad Catz, Inc.*, the plaintiff alleged that this video game controller infringed this design patent:

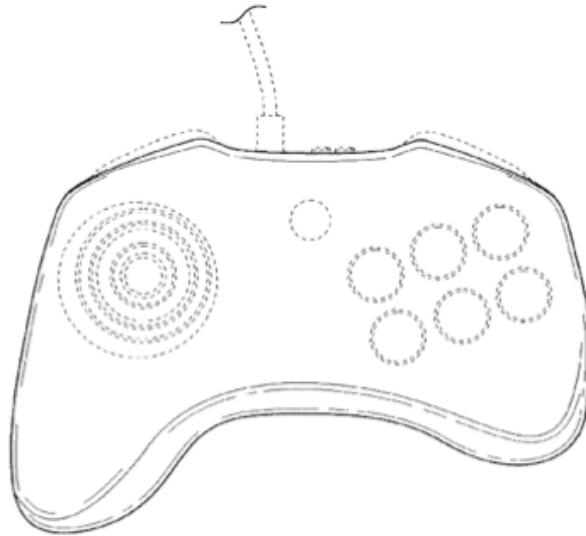

The judge dismissed the claim with prejudice under Federal Rule of Civil Procedure 12(b)(6), concluding that these designs were so “plainly dissimilar” under *Egyptian Goddess* that any attempt to amend the claim would be “futile.” *Performance Designed Prods. LLC v. Mad Catz, Inc.*, No. 3:16-cv-00629, 2016 WL 3552063, at \*6-7 (S.D. Cal. June 29, 2016).



## DESIGNS

In *Boost Oxygen, LLC v. Oxygen Plus, Inc.*, No. 0:17-cv-05004, 2020 WL 4582253, at \*6 (D. Minn. Aug. 10, 2020), the court ruled that this accused product was plainly dissimilar from this patented design:

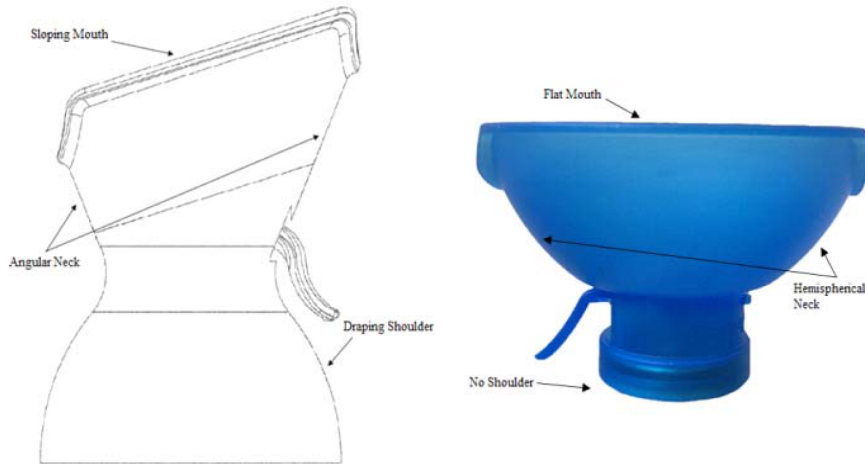

By contrast, in *C&A Mktg., Inc. v. GoPro, Inc.*, No. 1:15-cv-07854, 2016 WL 1626018, at \*1 (D.N.J. Apr. 25, 2016), the court ruled that these designs were *not* plainly dissimilar:

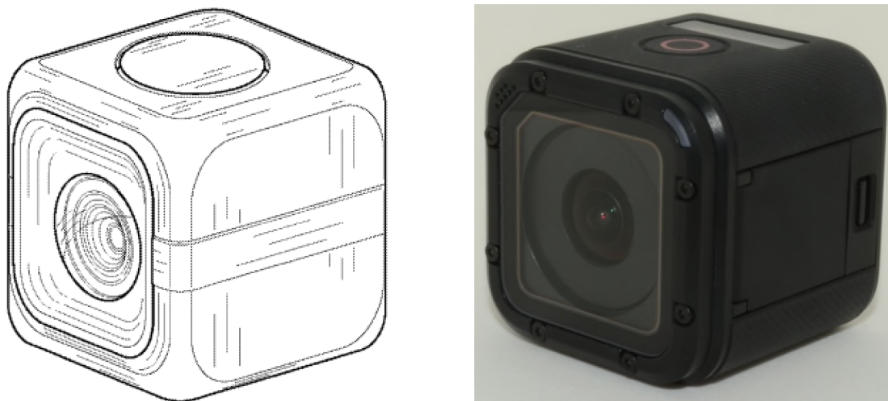

To be clear: A finding that an accused design is “not plainly dissimilar” is not the same as a finding of infringement. Even if the designs are not plainly dissimilar, there is still a second step of the *Egyptian Goddess* test. At step two, the accused infringer can introduce evidence of prior art designs to narrow the presumptive scope of the asserted patent. And the designs still must look the same to the ordinary observer. See Sarah Burstein, *Intelligent Design & Egyptian Goddess: A Response to Professors Buccafusco, Lemley & Masur*, 68 DUKE L.J. ONLINE 94 (2019).

And courts sometimes give—or allow juries to give—design patents a broader scope. The most notable outlier when it comes to scope may be *Apple v. Samsung*, where the jury found that this design patent for a graphical user interface was infringed by various devices, including this one:



See Amended Verdict Form at 7, *Apple Inc. v. Samsung Elecs. Co.*, No. 5:11-cv-01846 (N.D. Cal. Aug. 24, 2012), ECF 1931. See also Expert Report Of Susan Kare at 10, 32, *Apple Inc. v. Samsung Elecs. Co.*, No. 5:11-cv-01846 (N.D. Cal. May 17, 2012), ECF 927-25 (illustrations). Is the jury's verdict consistent with the other examples you've seen in this chapter? Samsung did not seek summary judgment of noninfringement on this and similar claims. See *Apple, Inc. v. Samsung Elecs. Co.*, No. 5:11-cv-01846, 2012 WL 2571719, at \*20 (N.D. Cal. June 30, 2012). Should it have done so? Should design patents be construed this broadly?

## B. Novelty & Nonobviousness

Like other types of inventions, a design must be novel and nonobvious to be patentable. 35 U.S.C. §§ 102, 103. Some commentators have described these as difficult hurdles for designs to satisfy. See, e.g., Janice M. Mueller & Daniel Harris Brean, *Overcoming the "Impossible Issue" of Nonobviousness in Design Patents*, 99 KY. L.J. 419, 434 (2011) (calling nonobviousness a "substantial hurdle" for designers); UMA SUTHERSANEN, *DESIGN LAW: EUROPEAN UNION AND UNITED STATES OF AMERICA* § 10.1, at 210 (2d ed. 2010) (stating that U.S. design patent law uses "a high standard of novelty"). As you read the cases that follow, think about whether you agree with these assessments.

DESIGNS

*High Point Design LLC v. Buyers Direct, Inc.*  
730 F.3d 1301 (Fed. Cir. 2013)

SCHALL, Circuit Judge.

Buyer's Direct, Inc. ("BDI") appeals from a final judgment of the United States District Court for the Southern District of New York holding BDI's asserted design patent invalid on summary judgment and also dismissing BDI's trade dress claims with prejudice. For the reasons set forth below, we reverse the grant of summary judgment of invalidity . . . and remand for further proceedings consistent with this opinion.

*Background*

I

BDI is the owner of U.S. Design Patent No. D598,183 (the "'183 patent") and the manufacturer of slippers known as SNOOZIES®. An exemplary pair of SNOOZIES® slippers is shown below:



The '183 patent recites one claim, for "the ornamental design for a slipper, as shown and described." [One] of the drawings included in the '183 patent [is] shown below:

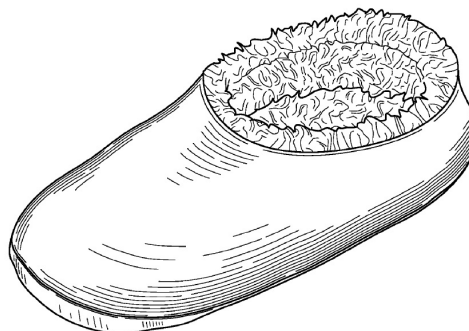

As additional design features, the '183 patent discloses two different soles: a smooth bottom (as shown in Figure 8) and a sole with two groups of raised dots (as shown in Figure 7):

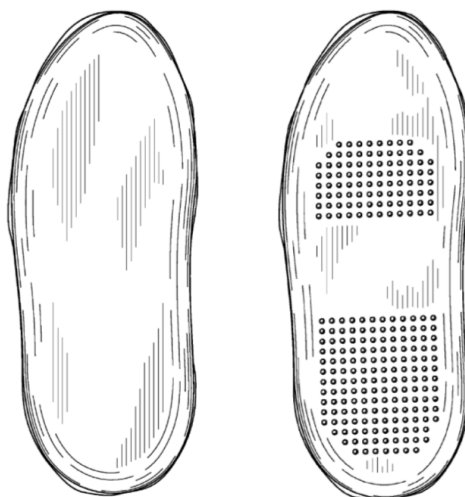

FIG. 8

FIG. 7

BDI alleges that SNOOZIES® are an embodiment of the design disclosed in the '183 patent.

II

High Point Design LLC (“High Point”) manufactures and distributes the accused FUZZY BABBA® slippers, which are sold through various retailers, including appellees Meijer, Inc., Sears Holdings Corporation, and WalMart Stores, Inc. (collectively, the “Retail Entities”). An exemplary pair of FUZZY BABBA® slippers is shown below:



On June 22, 2011, after becoming aware of the manufacturing and sale of FUZZY BABBA® slippers, BDI sent High Point a cease and desist letter, in which BDI asserted infringement of the '183 patent. With a responsive letter sent on July 6, 2011, High Point

## DESIGNS

included a copy of a complaint for declaratory judgment that it had filed five days earlier in federal district court. In the complaint, High Point alleged (1) that the manufacturing and sale of FUZZY BABBA® slippers did not infringe the '183 patent and (2) that the '183 patent is invalid and/or unenforceable.

In its answer to High Point's declaratory judgment complaint, filed on December 29, 2011, BDI lodged counterclaims for infringement of the '183 patent and for infringement of the trade dress found in BDI's SNOOZIES® slippers. That same day, BDI filed a third-party complaint alleging that the Retail Entities infringed the '183 patent and infringed BDI's trade dress based on sales of High Point's FUZZY BABBA® slippers.

### III

On May 15, 2012, the district court granted the motion for summary judgment, holding the '183 patent invalid on the ground that the design claimed in it was . . . obvious in light of the prior art . . . . The court characterized the '183 patent as disclosing "slippers with an opening for a foot that contain a fuzzy (fleece) lining and have a smooth outer surface." As to the prior art, the court found that a consumer apparel company, known as Woolrich, had, prior to the effective filing date of the '183 patent, sold two different models of footwear: the "Penta" and the "Laurel Hill" (collectively, the "Woolrich Prior Art"). The Penta and the Laurel Hill models are shown in photographs below:



FIG. 1



FIG. 4

J.A. 486–87 (Penta.)



FIG. 1



FIG. 4

J.A. 490–91 (Laurel Hill). The [district] court found that the Penta “looks indistinguishable from the drawing shown in the ‘183 Patent,” and that the Laurel Hill, “while having certain differences with the Penta slipper that are insubstantial and might be referred to as streamlining, nonetheless has the precise look that an ordinary observer would think of as a physical embodiment of the drawings shown on the ‘183 Patent.”

The district court also identified two secondary references—U.S. Design Patent Nos. D566,934 and D540,517 (collectively, the “Secondary References”)—that disclose “slippers with a pattern of small dots on the bottom surface.” Representative drawings from the Secondary References are shown below:

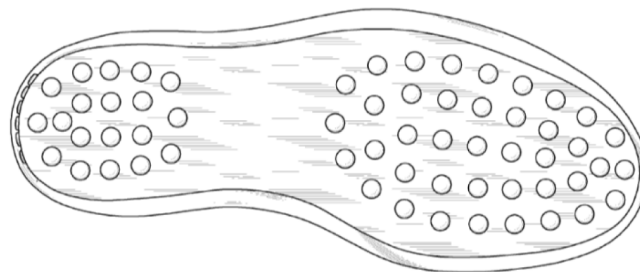
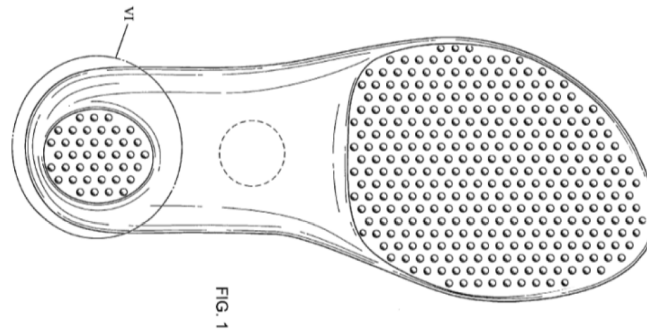

FIG. 1

U.S. Design Patent No. D566,934 fig. 1.

## DESIGNS



U.S. Design Patent No. D540,517 fig. 1. Based on these findings, the court concluded that the design in the '183 patent was invalid as obvious:

The overall visual effect created by the Woolrich prior art is the same overall visual effect created by the '183 patent. To an ordinary observer, they are the same slippers. The only difference between the slippers relates to the sole of the slippers, which is quite minor in the context of the overall slipper. Even if, however, this Court were to find that the differences in the sole design were of any note, the design of the dots on the '183 patent are anticipated by the dots on the Secondary References.

Since both of those design patents were noted on the face of the '183 patent, and since both relate to slippers, they would have been available to a slipper designer skilled in the art—and would have easily suggested the addition of “dots” to the sole of a slipper. Combining the dots shown on those two design patents with the prior art in the Woolrich slipper would have been obvious to any designer. That combination would have created a slipper with a virtually identical visual impression as the '183 patent.

### *Discussion*

On appeal, BDI challenges both the grant of summary judgment of invalidity . . . . This court reviews a district court’s grant of summary judgment under the law of the regional circuit. The Second Circuit reviews a grant of summary judgment without deference, construing the evidence in the light most favorable to the non-movant and drawing all reasonable inferences in that party’s favor. Summary judgment may only be granted when no “reasonable jury could return a verdict for the nonmoving party.”

## CHAPTER 12

### II

#### A

When assessing the potential obviousness of a design patent, a finder of fact employs two distinct steps: first, “one must find a single reference, a something in existence, the design characteristics of which are basically the same as the claimed design”; second, “once this primary reference is found, other references may be used to modify it to create a design that has the same overall visual appearance as the claimed design.” *Durling v. Spectrum Furniture Co.*, 101 F.3d 100, 103 (Fed. Cir. 1996) (internal quotations omitted); *see also Apple, Inc. v. Samsung Elecs. Co.*, 678 F.3d 1314, 1329 (Fed. Cir. 2012).

Under the first step, a court must both “(1) discern the correct visual impression created by the patented design as a whole; and (2) determine whether there is a single reference that creates ‘basically the same’ visual impression.” *Durling*, 101 F.3d at 103. The ultimate inquiry in an obviousness analysis is “whether the claimed design would have been obvious to a designer of ordinary skill who designs articles of the type involved.”

#### B

BDI asserts that the district court erred by using the Woolrich Prior Art as primary references because their design characteristics are not “basically the same as the claimed design,” as required under the first step set forth in *Durling*. Specifically, BDI relies on the Rake Declaration to argue that various design features distinguish the ’183 patent from the Woolrich Prior Art, including differences in (1) the fleece collars, (2) the height of the sidewalls, and (3) the thickness of the soles. According to BDI, these alleged differences create genuine issues of material facts as to whether the Woolrich Prior Art can properly serve as primary references.

Next, BDI asserts that the district court identified no motivation to modify the Woolrich Prior Art to achieve the “same overall visual appearance as the claimed design,” as required under the second step set forth in *Durling*. According to BDI, the court erred by ignoring the design features that distinguish the ’183 patent from the Woolrich Prior Art, and finding that the only differences relate to the soles.

BDI also argues that the district court failed to perform a proper obviousness analysis. First, BDI asserts that the court erred by applying an “ordinary observer” standard, because this court’s case law requires application of an “ordinary designer” standard in an obviousness analysis relating to a design patent. Second, BDI argues that the district court failed to properly communicate its reasoning in either step of the obviousness analysis. Finally, BDI asserts that the court erred by not addressing secondary considerations, including copying and commercial sales.



## DESIGNS

In response, High Point and the Retail Entities (collectively, the “Appellees”) assert that either the Penta or the Laurel Hill could act as the primary reference for the obviousness analysis because they are both “basically the same as the claimed design,” which, according to the Appellees, is all that is required under the first step. The Appellees assert that BDI seeks to apply a “virtual identity” standard in the first step, rather than the proper standard, which allows for minor differences. According to the Appellees, under this court’s case law, a district court can assess the “overall visual appearance,” as required by the second step under *Durling*, without expert testimony and “almost instinctively.”

The Appellees also argue that the district court properly discounted the Rake Declaration because obviousness should be assessed from the vantage point of the ordinary observer, not an ordinary designer such as Mr. Rake. According to the Appellees, the district court properly applied the ordinary observer standard to find obviousness based on the combination of either the Penta or the Laurel Hill with the Secondary References.

As to secondary considerations, the Appellees argue that BDI failed to show the nexus necessary to demonstrate that either the alleged copying or the commercial sale of SNOOZIES® support the nonobviousness of the ’183 patent. Specifically, the Appellees assert that BDI has not established that SNOOZIES® actually embody the ’183 patent, as is necessary to support BDI’s nonobviousness arguments.

## C

We first address the standard applied by the district court here. The use of an “ordinary observer” standard to assess the potential obviousness of a design patent runs contrary to the precedent of this court and our predecessor court, under which the obviousness of a design patent must, instead, be assessed from the viewpoint of an ordinary designer. Given this precedent, the district court erred in applying the ordinary observer standard to assess the obviousness of the design patent at issue.

Although obviousness is assessed from the vantage point of an ordinary designer in the art, “an expert’s opinion on the legal conclusion of obviousness is neither necessary nor controlling.” That said, an expert’s opinion may be relevant to the factual aspects of the analysis leading to that legal conclusion. For that reason, the district court erred by categorically disregarding the Rake Declaration.

We now turn to what we conclude were additional errors in the district court’s application of the two-step analysis set forth in *Durling*. As to the first part of the first step—“discerning the correct visual impression created by the patented design as a whole”—the district court erred by failing to translate the design of the ’183 patent into a verbal description. See *Durling*, 101 F.3d at 103 (“From this translation, the parties and

appellate courts can discern the internal reasoning employed by the trial court to reach its decision as to whether or not a prior art design is basically the same as the claimed design.”). The closest to the necessary description was the court’s comment characterizing the design in the ’183 patent as “slippers with an opening for a foot that can contain a fuzzy (fleece) lining and have a smooth outer surface.” This, however, represents “too high a level of abstraction” by failing to focus “on the distinctive visual appearances of the reference and the claimed design.” On remand, the district court should add sufficient detail to its verbal description of the claimed design to evoke a visual image consonant with that design.

As to the second part of the first step—“determining whether there is a single reference that creates ‘basically the same’ visual impression”—the court erred by failing to provide its reasoning, as required under this court’s precedent. Absent such reasoning, we cannot discern how the district court concluded that the Woolrich Prior Art was “basically the same as the claimed design,” so that either design could act as a primary reference. On remand, the district court should do a side-by-side comparison of the two designs to determine if they create the same visual impression. *See, e.g., Apple*, 678 F.3d at 1330 (comparing images of the claimed design to images of the asserted primary references). In addition, based on the record before us, there appear to be genuine issues of material fact as to whether the Woolrich Prior Art are, in fact, proper primary references. For this additional reason, summary judgment must be reversed.

To the extent that the obviousness of the ’183 patent remains at issue on remand, the district court will, after properly completing the first step under *Durling*, be in a better position to assess whether or not the Woolrich Prior Art, modified by the Secondary References, provide a design with the “same overall visual appearance as the claimed design,” as required under the second step of *Durling*.<sup>3</sup>

<sup>3</sup> Having setting forth the proper framework for the obviousness analysis, we take no position on whether the district court could or should find obviousness under the proper standard.

Finally, we turn to secondary considerations, which the district court did not address in the Final Decision. This court has held that “evidence rising out of the so-called ‘secondary considerations’ must always when present be considered en route to a determination of obviousness.” Here, BDI alleged both commercial success of the claimed design as well as copying. To the extent that the obviousness of the ’183 patent remains at issue on remand, the district court should address any evidence of secondary considerations.

For the foregoing reasons, we reverse the grant of summary judgment of obviousness and remand the case to the district court.

## Context &amp; Application

1. What test does the Federal Circuit use to evaluate whether or not a claimed design is obvious? Is that test consistent with the Supreme Court's decision in *KSR Int'l Co. v. Teleflex Inc.*, 550 U.S. 398 (2007)?

2. The "primary reference" is sometimes called a "*Rosen* reference." In *In re Rosen*, the C.C.P.A. held that "there must be a reference, a something in existence, the design characteristics of which are basically the same as the claimed design in order to support a holding of obviousness." 673 F.2d 388, 391 (C.C.P.A. 1982). This reference is required "whether the holding is based on the basic reference alone or on the basic reference in view of modifications suggested by secondary references." *Id.*

3. Once a proper primary reference is identified, "other references may be used to modify it to create a design that has the same overall visual appearance as the claimed design." *Durling v. Spectrum Furniture Co.*, 101 F.3d 100, 103 (Fed. Cir. 1996). But "secondary references may only be used to modify the primary reference if they are so related to the primary reference that the appearance of certain ornamental features in one would suggest the application of those features to the other." *Id.* What does that mean? The case law is less than clear. And in light of the high standard of visual similarity the Federal Circuit requires for primary references, few cases reach this second step at all. For more on these issues, see Sarah Burstein, *Visual Invention*, 16 LEWIS & CLARK L. REV. 169, 214 (2012).

4. The court states in *High Point* that in the design patent context, just like the utility patent context, "evidence rising out of the so-called 'secondary considerations' must always when present be considered en route to a determination of obviousness." Are these considerations a good fit for designs? Do you think that evidence of, say, commercial success or copying are relevant to the question of whether a claimed design would have been obvious to an ordinary designer?

5. In *High Point*, the Federal Circuit rules that "the district court erred by failing to translate the design of the '183 patent into a verbal description," citing *Durling v. Spectrum Furniture Co.*, 101 F.3d 100, 102 (Fed. Cir. 1996). Is requiring a detailed verbal description of a design when analyzing obviousness consistent with what the Federal Circuit said about the perils of verbal claim construction in *Egyptian Goddess*? The Federal Circuit addressed this issue in a footnote:

This court has required that in determining obviousness, a district court must attempt to "translate the visual descriptions into words" in order to communicate the reasoning behind the court's decision and to enable "the parties and appellate courts to discern the internal reasoning employed by the trial court." *Durling v.*

*Spectrum Furniture Co.*, 101 F.3d 100, 102 (Fed. Cir. 1996). Requiring such an explanation of a legal ruling as to invalidity is quite different from requiring an elaborate verbal claim construction to guide the finder of fact in conducting the infringement inquiry.

*Egyptian Goddess, Inc. v. Swisa, Inc.*, 543 F.3d 665, 679 n.1 (Fed. Cir. 2008) (*en banc*). Do you find this distinction persuasive?

*High Point Design LLC v. Buyers Direct, Inc.*  
621 F. App'x 632 (Fed. Cir. 2015)

CHEN, Circuit Judge.

This is the second time this case has been appealed to our court. In *High Point Design LLC v. Buyers Direct, Inc.*, 730 F.3d 1301 (Fed. Cir. 2013) (“*High Point I*”), we reversed the . . . grant of summary judgment of invalidity of the design patent belonging to Buyers Direct, Inc. (BDI). . . .

On remand, the district court again granted summary judgment, finding that: (1) the asserted patent was anticipated; (2) the accused products did not infringe; . . . .

BDI challenges each of these determinations on appeal. For the reasons set forth below, we reverse summary judgment of invalidity [and] affirm summary judgment of non-infringement . . . .

I

The background of the case is set forth in *High Point I* . . . . We recount below only the facts pertinent to the issues on appeal.

BDI owns a design patent for the ornamental appearance of a fuzzy slipper, U.S. Patent No. D598,183 (the D’183 patent). The D’183 patent is entitled “Slipper,” and recites one claim for “the ornamental design for a slipper, as shown and described” in eight figures. . . .

The claimed design discloses two embodiments for the slipper soles. One embodiment has a sole with two groups of raised dots, and the other has a sole with a smooth bottom.

BDI manufactures a slipper called the SNOOZIE® (Snoozie), which it contends is an embodiment of the design disclosed in the D’183 patent. . . .

High Point Design LLC (High Point) manufactures and distributes the accused FUZZY BABBA® slipper (Fuzzy Babba). . . .

## DESIGNS

### D

On remand, the district court again granted summary judgment of invalidity. This time the district court found that the D'183 patent was anticipated by the Woolrich Prior Art. The district court offered the following description of the claimed design in support of its decision:

To an ordinary observer, the '183 Patent is the design of a slipper with a formed body, a protrusion of fuzz or fluff, and a sole with some solidity. The outside of the slipper appears durable and looks to be made of a relatively tough material; the inside looks soft, plush, and made of a warm material. The sole appears to be fairly thick and looks sturdy.

Addressing each of the prior art designs in turn, the district court first determined that the Laurel Hill anticipated because it also had “a structured body, a soft-looking fluff surrounding the opening of the slipper, and a sole that appears durable and fairly thick.” The district court then found that the Penta also anticipated, concluding that the Penta was even more similar to the D'183 patent than the Laurel Hill. The court found that the Penta “conveys the visual effect of a slipper, the body and sole of which have some defined shape and solidity but which has a protrusion of fluff or fuzz emanating from the foot opening.” Although the district court noted that a close study of the patented and prior art designs revealed differences, those differences were “minor” and insufficient to defeat anticipation.

The district court also ruled in favor of High Point on grounds that the Fuzzy Babba slipper did not infringe the patented design. In particular, the district court found:

The Fuzzy Babba conveys the visual effect of an entirely soft and malleable body with an indistinguishable sole; it is soft and malleable all around. In contrast, the visual effect of the '183 Patent is of a formed body and sole with some solidity; and a body distinct from the sole.

### II

#### A

We turn first to the district court's grant of summary judgment on anticipation.

Design patents are presumed to be valid. 35 U.S.C. § 282(a). A party seeking to invalidate a patent on the basis of anticipation must do so by clear and convincing evidence. Design patent anticipation requires a showing that a single prior art reference is “identical in all material respects” to the claimed invention. In other words, the two designs must be substantially the same. Two designs are substantially the same “if the resemblance is such as to deceive an ordinary observer, inducing him to purchase one supposing it to be the other.” Anticipation is a question of fact. Summary judgment is

proper only when the evidence underlying anticipation is clear and convincing such that no reasonable fact-finder could find otherwise.

Viewing all evidence in the light most favorable to the non-moving party—BDI—we conclude that a reasonable jury could have found there was not clear and convincing evidence of anticipation.

In *High Point I*, we instructed that on remand, the district court should “add sufficient detail to its verbal description of the claimed design to evoke a visual image consonant with the claimed design.” We also instructed that the district court should perform a side-by-side comparison of the claimed and prior art designs as part of the proper obviousness determination. Notably, we cautioned that there appeared to be “genuine issues of material fact as to whether the Woolrich Prior Art are, in fact, proper primary references” for obviousness purposes under 35 U.S.C. § 103.

On remand, the district court did not perform a side-by-side comparison, but concluded that the claimed and prior art designs share the “same characteristics” because they share “a structured body, a soft-looking fluff surrounding the opening of the slipper, and a sole that appears durable and fairly thick.”

We find again that the district court fundamentally erred in its analysis by analyzing the designs from “too high a level of abstraction” and failing to focus “on the distinctive visual appearances of the reference and the claimed design.” Specifically, the court’s description does little more than point out the main concepts of the claimed design: a structured slipper having fuzzy material at the foot opening. In doing so, the court failed to properly consider the ornamental aspects of the designs at issue. There are numerous such features in the body, the fuzzy material, and the sole of the designs, all of which were overlooked in the district court’s analysis.

For example, there are meaningful differences between the curvatures of the slipper body designs. The body of the patented design has a distinct ‘S’ curve between the foot opening and the front of the slipper as viewed from the side, which ends in a downward slope toward the front of the body. By contrast, the Laurel Hill has a prominent upward curve near the front. The Penta is also different because it has a noticeably flatter, more even slope from the foot opening towards the front.

## DESIGNS

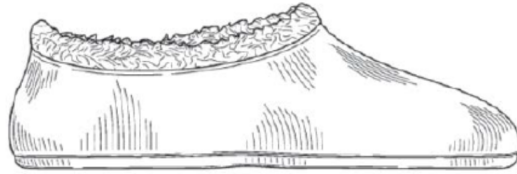

**D'183 patent,  
Figure 5**



**Laurel Hill  
Prior Art**



**Penta  
Prior Art**

There are also clear differences between the protruding fuzz of the claimed and prior art designs. In particular, the Woolrich Prior Art appears to differ from the claims in that both prior art slippers have a pronounced fleece overlap oriented outward and which obscures the top edge of the foot opening. By contrast, no such overlap is visible in the patented design.

We also find that the district court failed to take into consideration the substantial differences between the ornamental aspects of the soles of the claimed design and the prior art designs. As we stated in *Contessa Food Prods., Inc. v. Conagra, Inc.*, “our precedent makes clear that all of the ornamental features illustrated in the figures must be considered in evaluating design patent infringement.” 282 F.3d 1370, 1378 (Fed. Cir. 2002).

The district court did not address the ornamental aspects of the soles in the Remand Order, but stated in the 2012 Order that “the only difference between the slippers relates to the sole of the slippers, which is quite minor in the context of the overall slipper.” We disagree. There are unmistakable differences between the sole design of the D'183 patent and the Woolrich Prior Art. The patent claims one embodiment, shown in Figure 7, where the sole has dots. Those dots are arranged in a uniformly spaced pattern of rows and columns in two separate groups. One group is positioned closer to the front of the slipper, and narrows slightly toward the toe area. The other group is placed closer to the rear, and

has a corresponding taper toward the rear area. The other embodiment, shown in Figure 8, has a smooth sole. Neither of the Woolrich Prior Art designs has either of these design components.

The prior art designs instead each have their own distinct ornamental designs. The Laurel Hill sole has embedded within it images of four trees and two moose. The Laurel Hill also has a grooved border not present in the claimed design. The Penta sole has a large “WOOLRICH” image imprinted thereon and is also decorated with a distinct pattern. Like the Laurel Hill—but unlike the claimed design—the Penta also has a grooved border.

As we cautioned in *High Point I*, there appeared to be genuine issues of material fact regarding whether the Woolrich Prior Art properly served as base references under this court’s obviousness law. We now similarly hold that the evidence is not so clear and convincing such that a reasonable fact-finder could not find for BDI on anticipation. For these reasons, we reverse summary judgment of invalidity.

## B

We turn next to the district court’s grant of summary judgment of non-infringement.

Infringement is a question of fact and must be proved by a preponderance of the evidence. Summary judgment of non-infringement is appropriate when no reasonable fact-finder could find the accused design substantially similar to the claimed design.

Infringement of design patents is judged by the same test as anticipation—whether two designs are “substantially the same.” See *Egyptian Goddess*, 543 F.3d at 678 (adopting test set forth in *Gorham*, 81 U.S. at 528 as sole test for design patent infringement). Under *Egyptian Goddess*, where the claimed and accused designs are “sufficiently distinct” and “plainly dissimilar,” the patentee does not meet its burden of proving infringement. Only if the claimed and accused designs are not plainly dissimilar does the inquiry potentially benefit from comparison of the claimed and the accused designs . . . with the prior art. We agree with the district court that it is not necessary to resort to a comparison with the prior art in ruling on infringement here.

The district court conducted a side-by-side comparison between the claimed design and the accused Fuzzy Babba slippers, and concluded that “the Fuzzy Babba’s appearance evokes a soft, gentle image, while the D’183 patent appears robust and durable.” Finding that a consumer would not confuse the two designs, the court then granted summary judgment of non-infringement.



## DESIGNS



**Accused  
Fuzzy Babba  
design**

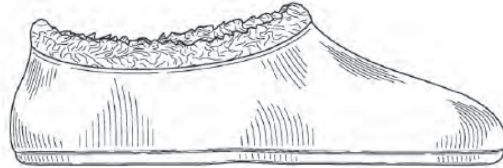

**D'183 patent,  
Figure 5**

We conclude that the patented and accused designs bring to mind different impressions. The Fuzzy Babba design appears soft and formless, whereas the claimed design appears structured and formed. These differences are reflected in the ornamental aspects of each of the designs. For example, the side profile of the Fuzzy Babba shows a relatively smooth, downward slope from the rear toward the front area of the slipper. By contrast, the D'183 patent design has a relatively defined, curved opening that is lower in the middle and higher at the edges. Further, the Fuzzy Babba has a relatively straight rear line, whereas the rear of claimed design bulges outward. The front areas of the two designs are also substantially dissimilar. The Fuzzy Babba has a relatively flatly sloping side profile, whereas the patented design has a curved profile, roughly following in an 'S' curve shape.

As we did with respect to invalidity, we also find that there are meaningful differences in the soles which affect the overall visual effect of the two designs. Unlike the D'183 patent design, the Fuzzy has a continuous distribution of dots throughout almost the entire length of the sole. These dots are of a constant width and in one group, in contrast to the varying width of dot columns displayed in Figure 7, and in further contrast to the embodiment in Figure 8 that has a smooth sole and no dots.

We recognize that both designs essentially consist of a slipper with a fuzzy portion extending upward out of the foot opening. Such high-level similarities, however, are not sufficient to demonstrate infringement.

BDI also argues that the district court erred by not performing a comparison of the accused Fuzzy Babba slipper to BDI's alleged commercial embodiment, the Snoozie. We have long-cautioned that it is generally improper to determine infringement by comparing an accused product with the patentee's purported commercial embodiment.

If a patentee is able to show that there is no substantial difference between the claimed design and the purported commercial embodiment, a comparison between that embodiment and the accused design is permissible. Contrary to BDI's suggestion, however, we have never mandated such comparisons and decline to do so here. The proper test for infringement is performed by measuring the accused products against the claimed design.

BDI also argues that the district court erred by failing to take into account how the accused products appeared as worn. We disagree. Even as worn, there are meaningful differences in the visual impression between the two designs. The Fuzzy Babba lacks the distinctive 'S' curve of the front area visible in Figure 4 of the claimed design. Moreover, the protrusion of fuzz in the Fuzzy Babba remains thicker toward the back than toward the front of the foot opening. And critically, there remain the aforementioned differences in the soles of the two designs.

For all these reasons, we affirm the district court's grant of summary judgment of non-infringement.

### Context & Application

1. What is the Federal Circuit's test for anticipation of a design patent? Is it an easy standard for a challenger to meet?

2. When can a patentee's commercial embodiment be used in the infringement inquiry? Who has the burden of proving that a product is, in fact, a commercial embodiment of a claimed design?

3. In *High Point*, the court mentioned that the patent-in-suit "disclose[d] two embodiments for the slipper soles." Although a design patent can only have one claim, "[m]ore than one embodiment of a design may be protected by a single claim. However, such embodiments may be presented only if they involve a single inventive concept according to the nonstatutory double patenting practice for designs." MPEP § 1504.05 (citing *In re Rubinfeld*, 270 F.2d 391 (C.C.P.A. 1959)). What does it mean to have the same inventive concept? To be a different "embodiment" of the same "design"? It's not clear. In practice, some attorneys report that it's really a matter of what you can "get past the examiner." But overaggressive embodiment claiming is a risky strategy, because the doctrine of prosecution history estoppel also applies to design patents. See *Pac. Coast Marine Windshields Ltd. v. Malibu Boats, LLC*, 739 F.3d 694, 697 (Fed. Cir. 2014).

4. In general, claiming using drawings is considered to be superior to claiming using photographs because the scope is generally broader. But is it true that line drawings are superior for every type of product? In this case, BDI's product arguably looked more like

the accused design than its patent drawings did. Would BDI have been better off if it had claimed its slipper design using photographs? Are there any other types of products that might be better depicted using photographs than using line drawings?

5. In *High Point*, the Federal Circuit also reversed the district court's determination that the claimed design was invalid for lack of ornamentality. See 730 F.3d 1301, 1317 (Fed. Cir. 2013). We'll learn more about that requirement—and how the Federal Circuit has interpreted it—in the next section.

### C. Ornamentality

Since 1902, the design patent statute has expressly required that a patentable design be “ornamental.” What does that word mean to you? “Decorative”? “Beautiful”? In this section, we'll explore how the Federal Circuit has interpreted this requirement. The answer may surprise you.

But first, let's look at how the C.C.P.A. interpreted the statutory requirement of ornamentality. In the case that follows, the C.C.P.A. considered the rejection of a design patent application for the following design for a gasket:

*Fig. 1.*

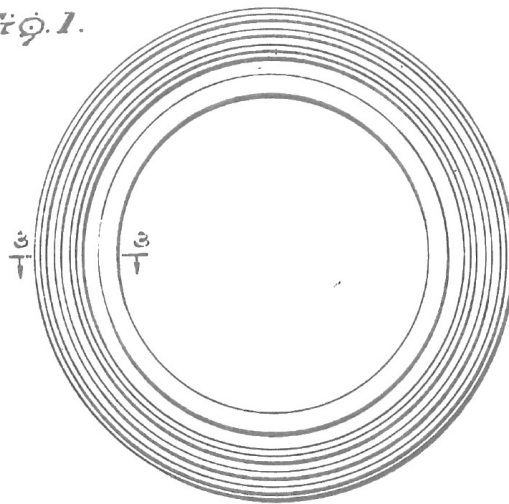

*Fig. 2.*

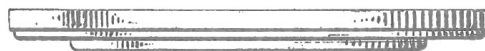

*In re Carletti*  
328 F.2d 1020 (C.C.P.A. 1964)

RICH, Judge.

This appeal is from the decision of the Patent Office Board of Appeals affirming the rejection of the claim in an application for a design patent, serial No. 56,122, filed May 28, 1959, for [a] "GASKET."

...

[T]he functionality of the elements asserted to distinguish the design from the prior art—as distinguished from the obviousness of those features—was a ground, if not a principle ground, of rejection. The Patent Office Solicitor's brief takes the same position.

While it cannot be said that the Patent Office has made out an iron-clad case of the functionality of the features relied on for patentability, more than a good case has been made out and the appellants have failed to refute it. In the first place we have in the record the military specification covering this gasket, MILP-40068, 9 June 1959, containing engineering drawings in great detail, specifying the exact position, dimensions, and tolerances of the grooves and ribs etc., without the slightest suggestion that they serve in any way as ornamentation. . . .

The record further shows such drums to be the common 55 gal. drums and the gasket to be for the threaded plug which closes the bung hole therein.

It seems naive in the extreme to believe that anyone would try to 'ornament' the rubber gasket on the under side of the bung cap for a gasoline drum, notwithstanding the seriocomic legal arguments presented by counsel for the Department of the Army. Common sense and but a slight familiarity with the requirements of gaskets both point to the obvious functionality of the groove and ribs on the gasket. . . .

The gasket at bar was standardized in a specification. This does not bespeak the existence of design in anything other than the sense of engineering 'design,' and certainly contraindicates the existence of the 'ornamental design' referred to in 35 U.S.C. § 171, under which a patent is here sought.

It is clear that appellants never invented an 'ornamental design.' The appearance of appellants' gasket seems as much dictated by functional considerations as is the appearance of a piece of rope, which, too, has ribs and grooves nicely arranged. The fact that it is attractive or pleasant to behold is not enough. Many well-constructed articles of manufacture whose configurations are dictated solely by function are pleasing to look upon, for example a hex-nut, a ball bearing, a golf club, or a fishing rod, the pleasure depending largely on one's interests. But it has long been settled that when a configuration

## DESIGNS

is the result of functional considerations only, the resulting design is not patentable as an ornamental design for the simple reason that it is not ‘ornamental’ – was not created for the purpose of ornamenting. In [*In re Garbo*, 287 F.2d 192 (C.C.P.A. 1961)] this court said:

It is true that a design may embody functional features and still be patentable, but in order to attain this legal status under these circumstances, the design must have an unobvious appearance, distinct from that dictated solely by functional considerations.

That is the principle which is believed to apply here.

Neither does it suffice to argue, as appellants do, that the ribs and grooves could have been less gracefully arranged than they are in their actual ‘balanced relationship.’ If obviousness enters into this case, it is at this point. If it is desired to employ a groove for flexibility and three concentric ribs to make a good seal on a flat drum head, what is more obvious than to arrange them with approximately equal spacing, as was done? But it was done without thought of ornament. The creation or origination of an ornamental design does not reside in the mere avoidance of dissymmetry.

For the foregoing reasons the decision is affirmed.

### Context & Application

1. How does the C.C.P.A. interpret the statutory term “ornamental” in *Carletti*? Does the court look to the product (what the designer did) or the process (the result of that process)? Is this an objective or a subjective standard—that is, does the court analyze the issue from the perspective of an ordinary designer or do they focus on the actions and motivations of the actual designer? Does the C.C.P.A.’s interpretation seem faithful to the text of the statute? Does it seem like good policy?

2. Recall that, in its first decision, the Federal Circuit adopted the holdings of the C.C.P.A. as precedents. *South Corp. v. United States*, 690 F.2d 1368, 1369 (Fed. Cir. 1982) (*en banc*). As you read the cases that follow, think about whether they are consistent with *Carletti*.

3. If you have studied (or are studying) trademark law, be careful with the terminology in this section. The words “ornamental” and “functional” do not mean the same things in design patent law that they do in trademark law. See Sarah Burstein, *Faux Amis in Design Law*, 105 TRADEMARK REP. 1455 (2015).

*In re Webb*

916 F.2d 1553 (Fed. Cir. 1996)

CLEVENGER, Circuit Judge.

This is an appeal from a decision of the U.S. Patent and Trademark Office Board of Patent Appeals and Interferences (“Board”) affirming the final rejection of the sole claim of appellants’ (“Webb”) U.S. Design Patent Application Serial No. 833,470. The claim for “the ornamental design for a grooved femoral hip stem prosthesis as shown and described,” was “rejected as being unpatentable under 35 U.S.C. § 171 as being directed to non-statutory subject matter.” The design can be appreciated from Figure 2 of the application reproduced below.

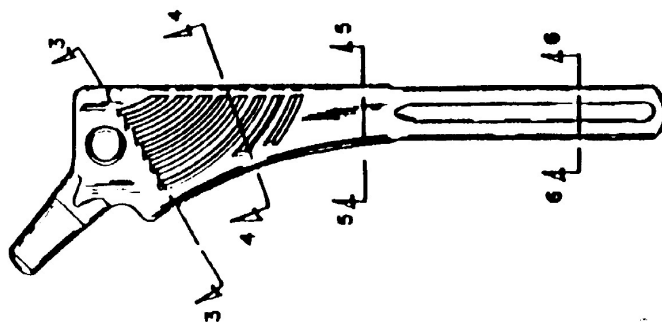

The Board affirmed the Examiner’s holding that the design, “clearly not intended to be visible in actual use,” “is not proper subject matter under 35 U.S.C. § 171.” The Board’s decision creates a *per se* rule that a design for an article which will not be visible in the final use for which the article was created is non-statutory subject matter even if the design is observed at some stage of the article’s commercial life. We reverse and remand.

## I

Hip stem prostheses of the design invented by Webb are metallic implants that are generally used by orthopedic surgeons to supplant the functioning of a diseased or broken femur, near the hip, where the femur is joined to the pelvis. According to Webb, and not disputed by the Patent and Trademark Office (“PTO”), surgeons are made aware of differing brands and types of prostheses through advertisements in professional journals and through trade shows, where the prostheses themselves are displayed. Advertisements that were put in the record prominently and visually display the features of the prostheses. Furthermore, the applicant’s agent submitted that “an implant’s appearance is observed by potential and actual purchasers, surgeons, nurses, operating room staff, and other hospital personnel.” After purchase, the prosthesis is surgically

## DESIGNS

implanted into a patient's body where the implant is to remain indefinitely. Neither party disputes that, after implantation, the prosthesis is no longer visible to the naked eye.

### II

In the Initial Office Action, the Examiner rejected the claim "under 35 U.S.C. 171 for the reason that the instant article is believed to be devoid of ornamentality, as comprehended by the statute. Articles of this type are not only completely hidden in use, but are devised to satisfy purely structural and mechanical requirements as well." The Examiner thus found the article to be unpatentable subject matter for two reasons: because it was purely functional and because it was concealed in normal use. In reply, Webb argued that the design was not purely functional since a "prosthetic implant could utilize the mechanical/utilitarian features/concepts and have a totally different visual appearance." Webb also argued that the "visual appearance can certainly draw attention to a particular implant at a trade show or in advertising" and, therefore, the design was visible during normal use.

In the Final Office Action, the Examiner stated:

Applicant argues that, while the design is functional in nature, it is still ornamental. While this may be true, it has been held that articles which are hidden in use are not proper subject matter for design patents.

There is not sound reason or logic for "normal use" to include the repair, service, replacement, sale or display of the article which incorporates the claimed design. While such occasions are of course "normal" in the sense of commonplace or routine occasions of an item's use, for patent purposes "normal use" should be limited to the ordinary functioning for which it was designed, not incidents in the article's life which are not integral to its function or purpose. Items are not designed for sale, display, replacement or repair.

The Board did not address the issue of functionality of the claimed design that had been raised in the Examiner's Initial Action. It affirmed the Examiner's final rejection of the claim as unpatentable subject matter because the article was not visible in what the Board considered to be its normal or intended use.

### IV

The issuance of design patents is limited by statute to designs that are ornamental. 35 U.S.C. § 171. Our predecessor court has affirmed the rejection of design applications that cannot be perceived in their normal and intended uses. For instance, the Court of Customs and Patent Appeals affirmed the rejection of a design claim for a vent tube placed in the wall of a frame house, stating that "it is well-settled that patentability of a design cannot be based on elements which are concealed in the normal use of the device to which the

design is applied.” *In re Cornwall*, 230 F.2d 457, 459 (1956). Even earlier, that court affirmed the rejection of a design claim for a vacuum cleaner brush. *In re Stevens*, 173 F.2d 1015 (1949). There the court noted:

Articles which are concealed or obscure are not proper subjects for design patents, since their appearance cannot be a matter of concern. Almost every article is visible when it is made and while it is being applied to the position in which it is to be used. Those special circumstances, however, do not justify the granting of a design patent on an *article such as here under consideration* which is always concealed in its normal and intended use.

*Id.* at 1016.

We read those cases to establish a reasonable general rule that presumes the absence of ornamentality when an article may not be observed. This is a sound rule of thumb, but it is not dispositive. In each case, the inquiry must extend to whether at some point in the life of the article an occasion (or occasions) arises when the appearance of the article becomes a “matter of concern.”

Here, we read the Board’s decision to have established a per se rule under § 171 that if an article is hidden from the human eye when it arrives at the final use of its functional life, a design upon that article cannot be ornamental. The rule in *Stevens* does not compel the Board’s decision. Instead, *Stevens* instructs us to decide whether the “article such as here under consideration”—a hip stem implant—“is always concealed in its normal and intended use.” The issue before us, then, is whether “normal and intended use” of these prosthetic devices is confined to their final use.

## V

Although we agree that “normal and intended use” excludes the time during which the article is manufactured or assembled, it does not follow that evidence that an article is visible at other times is legally irrelevant to ascertaining whether the article is ornamental for purposes of § 171. Contrary to the reasoning of the Examiner in this case, articles are designed for sale and display, and such occasions are normal uses of an article for purposes of § 171. The likelihood that articles would be observed during occasions of display or sale could have a substantial influence on the design or ornamentality of the article. “The law manifestly contemplates that giving certain new and original appearances to a manufactured article may enhance its salable value.” *Gorham Co. v. White*, 81 U.S. 511, 525 (1871).

In short, we construe the “normal and intended use” of an article to be a period in the article’s life, beginning after completion of manufacture or assembly and ending with the ultimate destruction, loss, or disappearance of the article. Although the period includes



all commercial uses of the article prior to its ultimate destination, only the facts of specific cases will establish whether during that period the article's design can be observed in such a manner as to demonstrate its ornamentality.

It is possible, as in *Stevens*, that although an article may be sold as a replacement item, its appearance might not be of any concern to the purchaser during the process of sale. Indeed, many replacement items, including vacuum cleaner brushes, are sold by replacement or order number, or they are noticed during sale only to assess functionality. In such circumstances, the PTO may properly conclude that an application provides no evidence that there is a period in the commercial life of a particular design when its ornamentality may be a matter of concern. However, in other cases, the applicant may be able to prove to the PTO that the article's design is a "matter of concern" because of the nature of its visibility at some point between its manufacture or assembly and its ultimate use. Many commercial items, such as colorful and representational vitamin tablets, or caskets, have designs clearly intended to be noticed during the process of sale and equally clearly intended to be completely hidden from view in the final use. Here, for example, there was ample evidence that the features of the device were displayed in advertisements and in displays at trade shows. That evidence was disregarded by the Board because, in its view, doctors should select implants solely for their functional characteristics, not their design. It is not the task of the Board to make such presumptions.

The decision of the Board is reversed and the case is remanded.

### Context & Application

1. What was the examiner's concern about the design claimed in *Webb*? Was it the same concern as the one that was in *Carletti*? If not, what does that tell us about the requirement of ornamentality?

2. Who is the ordinary observer in *Webb*? Do you think that healthcare purchasing decisions work the same way today that the court describes in *Webb*?

3. In *Webb*, the court emphasizes that the prosthetics are visible at the point of sale. Does that necessarily mean that the purchasers cared about what the implants look like? Should the "matter of concern" doctrine focus on the subjective preferences of any particular purchaser or should it focus on the preferences of purchasers more generally? In other words, if most doctors didn't actually care what the implants looked like, should those appearances be deemed a "matter of concern"? Either way, what kind of evidence would you use to prove something was (or was not) a "matter of concern"?

4. Near the end of *Webb*, the court says:

Many commercial items, such as colorful and representational vitamin tablets, or caskets, have designs clearly intended to be noticed during the process of sale and equally clearly intended to be completely hidden from view in the final use.

What assumptions is the court making here? Are those assumptions justified? Who is the ordinary observer of a vitamin? Of a casket? At what stage of those products' lifecycles do people actually care about the appearance of those items?

*Best Lock Corp. v. Ilco Unican Corp.*  
94 F.3d 1563 (Fed. Cir. 1996)

LOURIE, Circuit Judge.

Best Lock Corporation appeals from the final decision . . . in which the court held that Best Lock's U.S. Design Patent 327,636 was invalid. Because the court did not clearly err in finding that the claimed design was functional and hence not ornamental, we affirm.

*Background*

This case involves a design patent for a key "blade." A typical key consists of a bow, which allows the user to turn the key in a corresponding lock, and a blade, which is the portion of the key inserted into the lock's keyway. When a key is manufactured, the key blade is "blank," *i.e.*, the blade has not been cut or "bitted" with the combination required to operate the corresponding lock. Although a blank key blade will not operate the lock, the profile of the key blade is manufactured to fit into the corresponding lock's keyway. Subsequently, the blank key blade is cut to match the corresponding lock's combination.

In the replacement key market, a locksmith or a retail store with a key duplicating facility stocks blank key blades with various key profiles. The locksmith or retailer makes a replacement key by first selecting the appropriate blank key blade. This is done by matching the key blade profile with the corresponding lock keyway. Then, the locksmith or retailer cuts the blade of the key blank with the combination required to operate the lock.

Best Lock manufactures and sells locks and keys used to maintain security at industrial, commercial, and institutional facilities. At these facilities, it is often feared that the keys used in their locks may readily be duplicated. Consequently, key and lock manufacturers, including Best Lock, have attempted to restrict unauthorized access to duplicate key blanks by obtaining utility or design patent protection on the keys. By obtaining patent protection, a company hopes to control the market for duplicate key blanks during the life of the patent.

## DESIGNS

Best Lock is the assignee of the two patents that were at issue before the district court, U.S. Patent 5,136,869 and U.S. Design Patent 327,636. The '869 patent, entitled "High Security Key and Cylinder Lock Assembly," claims an improved key blade and cylinder lock assembly that provides a wider key profile than standard keys and includes other features to deter lock picking. The '636 patent, entitled "Portion of a Key Blade Blank," claims the ornamental design for the operative portion of a key blade blank. In addition to the '636 design patent, Best Lock . . . is the assignee of 34 design patents directed to keyways designed to mate with the key blades claimed in Best Lock's 34 key blade design patents. The '636 patent is the only design patent at issue on appeal.

Figures 1–5 of the '636 design patent are shown below:

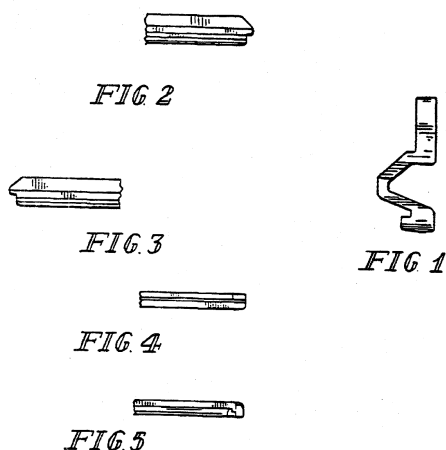

Ilco manufactures duplicate and replacement key blanks for existing locks. It sells its replacement key blanks to locksmiths and replacement key retailers. In 1993, Ilco copied the design of a Best Lock key, which had a key blade shaped like the design shown in the '636 patent. It subsequently distributed key blanks with that key blade shape at the annual convention of the Associated Locksmiths of America. In response, Best sued Ilco, alleging, inter alia, infringement of the '636 design patent and the '869 utility patent. Ilco counterclaimed, seeking a declaratory judgment of invalidity and noninfringement of both patents.

After a ten-day bench trial, the district court held that . . . the '636 design patent was invalid. . . . The court further found that the design patent was invalid because the shape of the blank key blade was dictated by its function. Best Lock appeals . . . .

### *Discussion*

Under 35 U.S.C. § 171, a design patent may be granted for a "new, original and ornamental design for an article of manufacture." However, if the design claimed in a

design patent is dictated solely by the function of the article of manufacture, the patent is invalid because the design is not ornamental. A design is not dictated solely by its function when alternative designs for the article of manufacture are available. We review for clear error the district court's determination that the design claimed in the '636 patent is functional.

On appeal, Best Lock argues that the court erred in holding the '636 design patent invalid as being directed solely to a functional design. As support, it asserts that although a particular key and its corresponding lock must mate to operate the lock, an unlimited number of key blade and corresponding keyway designs are available. Choice of any particular design is arbitrary. Thus, Best Lock maintains that the key blade blank may have any number of different shapes and is therefore not dictated solely by functional concerns.

We disagree. The design shown in the claim of the '636 patent is limited to a blank key blade as shown in Figures 1–5 of the patent. Best Lock did not claim a design for the entire key. The parties do not dispute that the key blade must be designed as shown in order to perform its intended function—to fit into its corresponding lock's keyway. An attempt to create a key blade with a different design would necessarily fail because no alternative blank key blade would fit the corresponding lock. In fact, Best Lock admitted that no other shaped key blade would fit into the corresponding keyway, and it presented no evidence to the contrary. Therefore, we find no clear error in the court's finding that the claimed key blade design was dictated solely by the key blade's function. Any aesthetic appeal of the key blade design shown in the '636 patent is the inevitable result of having a shape that is dictated solely by functional concerns.

Further, Best Lock's assertion that a variety of possible shapes of interfaces between keys and locks exists does not compel a different result. Clearly, different interfaces between key blades and corresponding lock keyways can be designed to permit the combination to function as a lock and key set. However, Best Lock's patent does not claim the combination of a lock and corresponding key. Instead, the claim in the '636 design patent is limited to a key blade, which must be designed as shown in the '636 patent in order to perform its intended function.

Moreover, the fact that Best Lock also has a design patent on the keyway that mates with the key blade shown in the '636 patent does not alter our analysis. The existence of a separate patent on the keyway is irrelevant to the construction of the '636 patent claim and to the ultimate determination that the claimed design is dictated solely by function. The validity of a patent must be evaluated based on what it claims rather than on the totality of the claims of multiple patents.

## DESIGNS

For the foregoing reasons, the district court's finding that the claimed design is solely governed by functional concerns is not clearly erroneous. Consequently, we affirm its resulting conclusion that the '636 patent is invalid under 35 U.S.C. § 171 for failure to satisfy the statute's ornamentality requirement.

NEWMAN, Circuit Judge, dissenting.

I respectfully dissent. The design of this key blade profile meets the statutory criteria of design patent subject matter. . . .

Whether the design of the D'636 patent is otherwise patentable, for example on the criteria of originality or non-obviousness, was not reached by the district court and is not before us. However, the panel majority has misapplied 35 U.S.C. § 171 in holding that the arbitrary design of the key profile is "functional" because it mates with its matching keyway.

The design of the key profile is not removed from access to the design statute because the key fits a matching keyway. That two articles are designed in harmony does not deprive the design of access to the design patent law. The design of the key profile is not determined by the function of the key to fit the lock. In the case at bar there are said to be "thousands" of alternative key blade profiles.

. . . The statute requires that the subject of a design patent be an ornamental design of a useful object. However, "ornamental" does not always mean artistic or pleasing to the eye. The Court of Customs and Patent Appeals early recognized that "the beauty and ornamentation requisite in design patents is not confined to such as may be found in the 'aesthetic or fine arts.'" *In re Koehring*, 17 C.C.P.A. 774, 37 F.2d 421, 422 (1930).

Recognizing that ornamentation is in the eye of the beholder, the courts have sought a more objective standard in the general rule that a design is "ornamental" for purposes of 35 U.S.C. § 171 when it is not primarily functional. *See In re Carletti*, 328 F.2d 1020 (1964). However, the article itself must have a utility in order for its design features to be patentable under 35 U.S.C. § 171. *See L.A. Gear, Inc. v. Thom McAn Shoe Co.*, 988 F.2d 1117, 1123 (Fed. Cir. 1993) ("A design patent is directed to the appearance of an article of manufacture. An article of manufacture necessarily serves a utilitarian purpose, and the design of a useful article is deemed to be functional when the appearance of the claimed design is 'dictated by' the use or purpose of the article.").

If the design is dictated by the function performed by the article of manufacture, the design is not patentable. A design is "not dictated by function alone" when there are alternative designs or configurations available for the article of manufacture, as in the case before us.

. . .

Courts have measured the term “ornamental” by the non-functionality that distinguishes the subject of a design patent from a utility patent, while recognizing that the design of a useful article is not insulated from the utility of the article. A review of patentable designs in general illustrates the mixture of functional and non-functional features embraced in the patented design.

An effective design patent law must recognize the distinction between functionality of the article and of the particular design of the article or features thereof. *See L.A. Gear, supra*, (the sneaker tongue, moustache, delta wing, and side mesh, were useful parts of the sneaker, but the overall design of these features and the shoe was not dictated by function alone). This interaction of form and function does not remove the design from the statutory scope of the design patent law, or defeat the statutory patentability of a primarily non-functional design—although it is not always easy to draw a bright line between the functionality of an article and its design, as discussed by J.H. Reichman, *Design Protection and the New Technologies: The United States Experience in a Transnational Perspective*, 19 BALT. L.REV. 6 (1989), for design patents often appear on quite mundane articles of manufacture.

The design of the key blade profile is primarily non-functional, as the Patent and Trademark Office recognized in granting the patent in suit. . . .

. . .

The parties to this litigation agree that there are myriad possible designs of key profiles. All keys require, of course, mating keyways. In holding that because the key must fit a keyway, the abstract design of the key profile is converted to one solely of function, the court creates an exception to design patent subject matter. An arbitrary design of a useful article is not statutorily excluded from § 171 simply because in use it interacts with an article of complementary design. Although precedent is sparse, it is contrary to this holding. In *Motorola Inc. v. Alexander Mfg. Co.*, 786 F. Supp. 808 (N.D. Iowa 1991), the only United States case on this point of which we are aware, the court considered a design patent for a battery housing intended for use in a portable phone. Since the battery housing had to fit into the phone and a battery charger, the accused infringer argued that this function dictated the design. The court disagreed:

The design of the battery housing was not dictated by the design of the battery charger because the charger did not exist when the housing was designed. The design of the phone was done concurrently with the battery housing. Therefore, the design of the battery housing cannot fairly be said to have been “dictated” by the design of the phone.

This reasoning is equally apt in this case. The design of the key profile was not dictated by the design of the keyway, and indeed the two share the same arbitrary design.

In sum, the fact that the key blade is the mate of a keyway does not convert the arbitrary key profile into a primarily functional design. It is not the design of the key profile that is functional, but the key itself. Thus I must, respectfully, dissent from the ruling of the panel majority that the design of the key blade profile is not patentable because the key blade requires a mating keyway.

### Context & Application

1. According to the majority, what was the problem with the design claimed in *Best Lock*? Was it a “functionality” problem (like in *Carletti*) or a “matter of concern” problem (like in *Webb*)?

2. In this case, “Best Lock admitted that no other shaped key blade would fit into the corresponding keyway.” If Best Lock hadn’t made that admission, would (or should) the case have come out a different way?

3. In her dissent, Judge Newman says that an article of manufacture “must have a utility in order for its design features to be patentable under 35 U.S.C. § 171,” citing *L.A. Gear, Inc. v. Thom McAn Shoe Co.*, 988 F.2d 1117, 1123 (Fed. Cir. 1993). While *L.A. Gear* does contain language that supports that proposition, that language is *dicta*. It is also contrary to history and practice. An “article of manufacture” is not the same as a “useful article,” as the latter term is defined in the Copyright Act. See 17 U.S.C. § 101 (“A ‘useful article’ is an article having an intrinsic utilitarian function that is not merely to portray the appearance of the article or to convey information. An article that is normally a part of a useful article is considered a ‘useful article.’”). Designs for items that would be considered “useful articles,” like statues, have always been considered design patentable subject matter. See Act of Aug. 29, 1842, ch. 263, § 3, 5 Stat. 543, 543-44 (providing protection for, among other things, “any new and original design for a bust, statue, or bas relief or composition in alto or basso relieve . . .”).



In *Best Lock*, both the majority and dissent in focused on alternative designs as the key to the functionality inquiry. But the year after *Best Lock* was decided, the Federal Circuit suggested—in what is arguably *dicta*—that there could be other factors to consider. In *Berry Sterling Corp. v. Pescor Plastics, Inc.*:

The patented container design was apparently developed in response to an industry-wide solicitation by the Coca Cola Company requesting the development of a car cup for its “Coke to Go” program. In order to receive consideration, the

## CHAPTER 12

cups had to meet the following criteria: (1) they had to have a 32 ounce capacity; (2) they had to have a spillproof lid; (3) they had to fit in a majority of car cup holders; (4) they had to be short enough to fit under the valve of a soda dispenser; and (5) they had to have a low production cost.

122 F.3d 1452, 1453 (Fed. Cir. 1997). Here is a representative view of the claimed design:

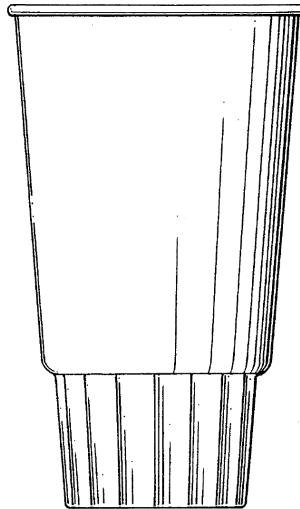

U.S. Patent D362,368, fig. 3. The district judge granted summary judgment for the defendant, concluding that the design was invalid due to functionality. The Federal Circuit reversed because “[t]he district court imposed the limitations of the manufacturing specifications for the ‘Coke to Go’ program cup on the underlying article of manufacture thereby unduly limiting the scope of the claimed design.” 122 F.3d at 1455.

After deciding that the grant of summary judgment had to be vacated and remanded, the Federal Circuit stated that:

[T]he district court acknowledged that there may well be alternative existing designs of cups similar to those claimed in the ‘368 patent, but apparently did not consider the alternative designs important to deciding whether the ‘368 patent is invalid for functionality. We have held that “when there are several ways to achieve the function of an article of manufacture, the design of the article is more likely to serve a primarily ornamental purpose.” Berry argues that this language . . . coupled with the existence of the alternative designs, save the ‘368 patent from the functionality challenge, and that the district court erred in not giving such effect to the alternative designs. The failure of the court to give dispositive effect to the existence of alternative designs in its validity analysis is not error. The



## DESIGNS

presence of alternative designs may or may not assist in determining whether the challenged design can overcome a functionality challenge. Consideration of alternative designs, if present, is a useful tool that may allow a court to conclude that a challenged design is not invalid for functionality. As such, alternative designs join the list of other appropriate considerations for assessing whether the patented design as a whole—its overall appearance—was dictated by functional considerations. Other appropriate considerations might include: whether the protected design represents the best design; whether alternative designs would adversely affect the utility of the specified article; whether there are any concomitant utility patents; whether the advertising touts particular features of the design as having specific utility; and whether there are any elements in the design or an overall appearance clearly not dictated by function.

*Id.* at 1455–56. Is this language holding or *dicta*? If it is a holding, can you reconcile this language with *Best Lock* and the cases cited therein?

Following *Berry Sterling*, other panels of the Federal Circuit stated that the test was limited to the question of whether or not there were alternative designs. In *Seiko Epson Corp. v. Nu-Kote Int'l, Inc.*, the court stated the test as follows: “The ‘ornamental’ requirement of the design statute means that the design must not be governed solely by function, i.e., that this is not the only possible form of the article that could perform its function.” 190 F.3d 1360, 1368 (Fed. Cir. 1999) (citing *L.A. Gear, Inc. v. Thom McAn Shoe Co.*, 988 F.2d 1117, 1123 (Fed. Cir. 1993)). Another panel quoted and followed the *Seiko* formulation of the functionality test in *Rosco, Inc. v. Mirror Lite Co.*, 304 F.3d 1373, 1378 (Fed. Cir. 2002). Here is the design that the Federal Circuit deemed to be not invalid as functional in *Seiko Epson*:

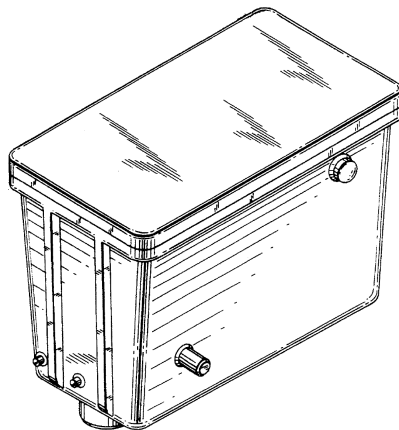

Ink Cartridge, U.S. Patent D351,190, fig. 1.

CHAPTER 12

Here is the design that the Federal Circuit deemed to be not invalid as functional in *Rosco*:

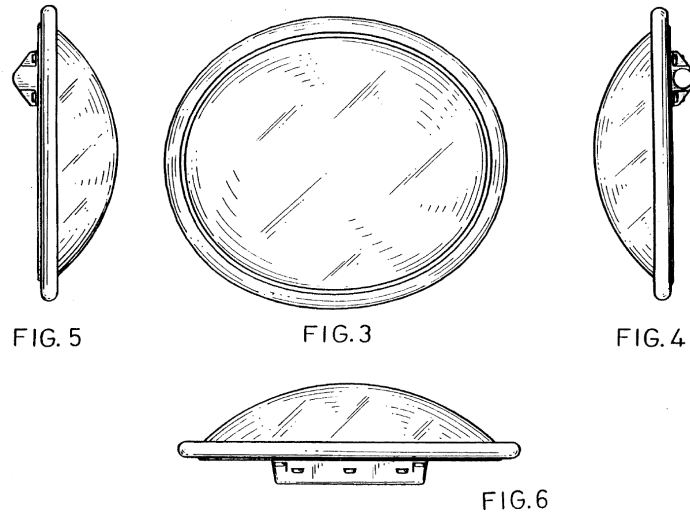

Automotive Mirror, U.S. Patent D346,357.

In 2006, another Federal Circuit panel adopted the *Berry Sterling* factors to invalidate these designs for medical patient identification labels:

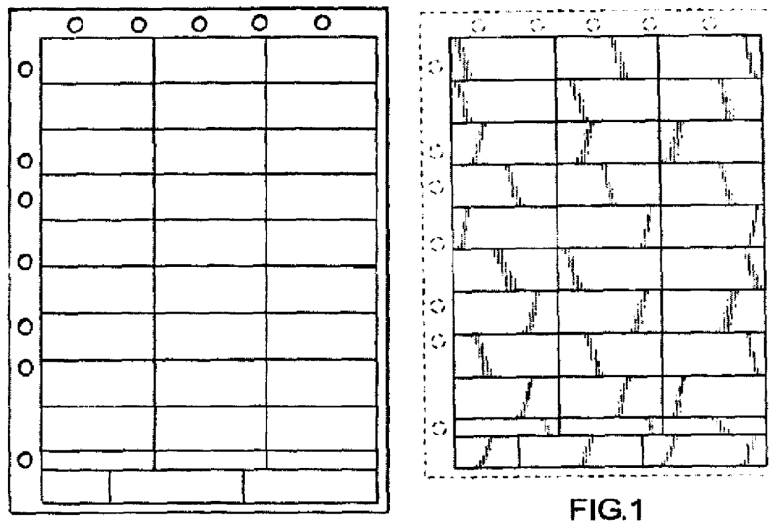

*PHG Techs., LLC v. St. John Companies, Inc.*, 469 F.3d 1361 (Fed. Cir. 2006) (U.S. Patent Nos. D496,405 and D503,197). Another Federal Circuit panel attempted to reconcile these lines of precedent in the case that follows.

*Ethicon Endo-Surgery, Inc. v. Covidien, Inc.*  
796 F.3d 1312 (Fed. Cir. 2015)

CHEN, Circuit Judge.

Plaintiffs-appellants Ethicon Endo–Surgery, Inc. and Ethicon Endo–Surgery, LLC sued defendants-appellees Covidien, Inc. and Covidien LP in the U.S. District Court for the Southern District of Ohio for alleged infringement of several utility and design patents related to ultrasonic surgical devices. After the close of discovery, the district court granted Covidien’s motions for summary judgment, concluding that . . . U.S. Patent Nos. D661,801 (the D’801 patent), D661,802 (the D’802 patent), D661,803 (the D’803 patent), and D661,804 (the D’804 patent) (collectively, the Design Patents) are invalid as functional and in the alternative, not infringed. . . .

...

As for the Design Patents, we reverse the district court’s grant of invalidity based on functionality. The district court evaluated the claimed designs using too high a level of abstraction, focusing on the unclaimed utilitarian aspects of the underlying article instead of the claimed ornamental designs of that underlying article. We affirm, however, the district court’s grant of summary judgment of noninfringement of the Design Patents. After the functional aspects of the claimed designs are properly excluded from the infringement analysis, the claimed ornamental designs are plainly dissimilar from the ornamental design of Covidien’s accused products. . . .

I

The patents-in-suit are directed to surgical instruments that use ultrasonic energy created by blades vibrating at high frequencies to cut tissue and blood vessels. These surgical instruments also use the heat generated from the friction of the blade vibrating against the blood vessel to coagulate and seal those blood vessels in order to prevent bleeding. Ethicon develops, manufactures, and sells such ultrasonic surgical instruments. After Covidien launched a competing line of ultrasonic surgical equipment, Ethicon sued Covidien, alleging infringement of the utility and design patents at issue in this appeal, among others. Both parties waived their rights to a jury trial and agreed to a bench trial on all disputed issues. . . . Covidien successfully moved for summary judgment of invalidity and/or noninfringement of the asserted patent claims. The district court entered a stipulated final judgment of noninfringement and/or invalidity of all patents-in-suit in favor of Covidien. . . .

## II

We review the grant of summary judgment under the law of the regional circuit. The Sixth Circuit reviews an order granting summary judgment de novo.

## C

The Design Patents claim particular ornamental designs of an ultrasonic surgical device. The D'801 patent claims a particular ornamental design of an inverted "U"-shaped trigger. The D'802 patent claims the overall appearance of the ornamental design of the "U"-shaped trigger and the particular ornamental design of a rounded and fluted torque knob positioned above and forward from the trigger. The D'803 patent claims the overall appearance of the ornamental design of the "U"-shaped trigger and the particular ornamental design of a rounded activation button positioned directly above the trigger. The D'804 patent claims the overall appearance of the ornamental designs of the "U"-shaped trigger, the fluted torque knob, and the rounded activation button, with the torque knob and the button positioned relative to the trigger as in the D'802 and D'803 patents, respectively. A figure from the D'804 patent, depicting the ornamental designs of the trigger, torque knob, and button claimed in various combinations and relative positions by the Design Patents, is reproduced below:

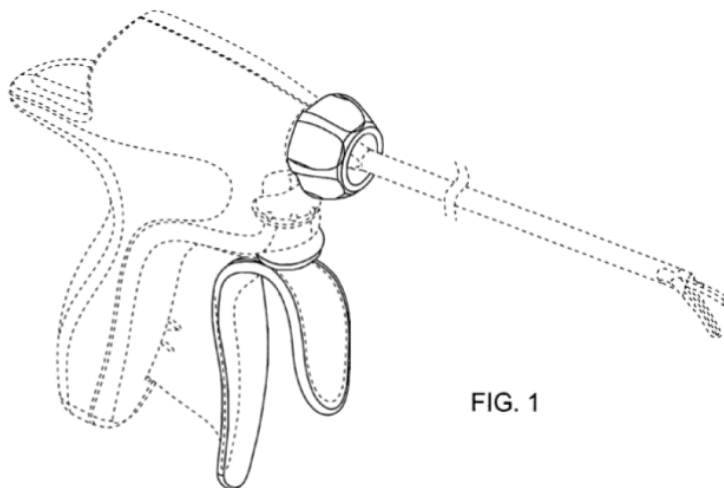

The district court concluded that the claimed designs in the Design Patents were all dictated by function and were therefore invalid. Specifically, the district court determined that under each consideration for assessing functionality identified in *PHG Technologies v. St. John Companies*, 469 F.3d 1361, 1366 (Fed. Cir. 2006), Ethicon's claimed designs were dictated by function. In the alternative, the district court found that because each of the designs of the trigger, torque knob, and button must be "factored out" under *Richardson*

## DESIGNS

*v. Stanley Works, Inc.*, 597 F.3d 1288 (Fed. Cir. 2010), the Design Patents had no scope, and therefore Covidien’s accused design could not infringe the Design Patents. The district court also found that even if the functional elements were not factored out, there was no infringement under the ordinary observer test laid out in *Egyptian Goddess, Inc. v. Swisa, Inc.*, 543 F.3d 665 (Fed. Cir. 2008) (*en banc*). Specifically, the district court found that the “highly sophisticated” ordinary observer in the “highly complex medical device purchasing process” would find that the claimed designs and the design of Covidien’s accused ultrasonic shears were plainly dissimilar.

### 1

Design patents enjoy the same presumption of validity as utility patents under 35 U.S.C. § 282. Thus, Covidien has the burden to prove invalidity of the Design Patents by clear and convincing evidence. We have described as “stringent” this standard as it applies to invalidating design patents on grounds of functionality. *Rosco, Inc. v. Mirror Lite Co.*, 304 F.3d 1373, 1378 (Fed. Cir. 2002). We review the district court’s finding that the patented designs are dictated by their function for clear error.

... If a particular design is essential to the use of an article, it cannot be the subject of a design patent. *L.A. Gear*, 988 F.2d at 1123. We have found designs to be essential to the use of an article when the claimed design is “dictated by” the use or purpose of the article. Design patents on such primarily functional rather than ornamental designs are invalid.

In determining whether a claimed design is primarily functional, “the function of the article itself must not be confused with ‘functionality’ of the design of the article.” *Hupp v. Siroflex of Am., Inc.*, 122 F.3d 1456, 1462 (Fed. Cir. 1997). In *Hupp*, we separated the function inherent in a concrete mold—producing a simulated stone pathway by molding concrete—from the particular pattern of the stone produced by the mold itself—an aesthetic design choice. Thus, even though the claimed design pattern was embedded within the functional concrete mold, the proper analysis required a determination of whether the design pattern within the mold—and not the concrete mold itself—was “dictated by” its function. Because there was no utilitarian reason the mold had to impress the particular claimed rock walkway pattern into the concrete, we determined that the claimed design was “primarily ornamental,” and not invalid as functional. In *High Point Design LLC v. Buyers Direct, Inc.*, we found that the district court had incorrectly relied on the functional aspects of a slipper—a seam connecting two components, a curved front accommodating the foot, an opening facilitating ingress and egress of the foot, a forward lean of the heel keeping the heel in place, and a fleece interior providing warmth—to find the particular ornamental design of that slipper to be impermissibly functional. We explained that a claimed design was not invalid as functional simply because the “primary features” of the design could perform functions. As with its analysis on other validity

grounds, the district court used “too a high a level of abstraction” in assessing the scope of the claimed design.

By contrast, in *Best Lock*, we affirmed a district court’s determination that a design patent to the blade of a key was invalid as functional, finding no clear error in the district court’s conclusion that the claimed key blade design was dictated by functional concerns. In *Best Lock*, the claimed design was limited to a specific shape of a blank key blade. The parties did not dispute that the claimed key blade shape was designed specifically to perform its intended function—to fit into a similarly-shaped cylinder lock keyhole. Further, the patentee presented no evidence of alternative compatible key blade designs, admitting that no differently-shaped key blade could fit into the keyhole of the corresponding cylinder lock. Because no alternative design would allow the underlying article to perform its intended function, we determined the district court did not clearly err by finding that the claimed key blade design was dictated by function, and therefore invalid.

We have also instructed that the overall appearance of the article—the claimed design viewed in its entirety—is the basis of the relevant inquiry, not the functionality of elements of the claimed design viewed in isolation. For example, we acknowledged in *L.A. Gear* that certain elements comprising the claimed design of an athletic sneaker each had a utilitarian purpose, including a “delta wing” supporting the foot and reinforcing the shoelace eyelets, side mesh paneling further supporting the foot, a “moustache” at the back of the shoe cushioning the Achilles tendon and reinforcing the rear of the shoe, and the particular positioning of each of these elements within the design of the shoe. Nevertheless, we explained that “the utility of each of the various elements that comprise the design is not the relevant inquiry with respect to a design patent” because whether a design is primarily functional or primarily ornamental requires viewing the claimed design “in its entirety.”

We have not mandated applying any particular test for determining whether a claimed design is dictated by its function and therefore impermissibly functional. We have often focused, however, on the availability of alternative designs as an important—if not dispositive—factor in evaluating the legal functionality of a claimed design. For example, the district court in *L.A. Gear* referenced the evidence of many alternative designs that accomplished the same functionality associated with the underlying athletic sneaker. 988 F.2d at 1123. In view of that evidence, we noted that “when there are several ways to achieve the function of an article of manufacture, the design of the article is more likely to serve a primarily ornamental purpose.” *Id.* See also *Rosco*, 304 F.3d at 1378 (“If other designs could produce the same or similar functional capabilities, the design of the article in question is likely ornamental, not functional.”); *Best Lock*, 94 F.3d at 1566 (same); *Hupp*, 122 F.3d at 1460 (same).

## DESIGNS

Here, the district court appeared to discount the existence and availability of alternative designs in determining that the claimed Design Patents were “primarily functional” based on its evaluation of the five considerations identified in *PHG*, 469 F.3d at 1366 (quoting *Berry Sterling*, 122 F.3d at 1456). In *Berry Sterling*, we vacated and remanded a district court’s grant of summary judgment of invalidity where it had failed to “elicit the appropriate factual underpinnings for a determination of invalidity of a design patent due to functionality.” In our instructions on remand, we explained that where the existence of alternative designs is not dispositive of the invalidity inquiry, the district court may look to several other factors for its analysis:

whether the protected design represents the best design; whether alternative designs would adversely affect the utility of the specified article; whether there are any concomitant utility patents; whether the advertising touts particular features of the design as having specific utility; and whether there are any elements in the design or an overall appearance clearly not dictated by function.

We explained that evaluating these other considerations “might” be relevant to assessing whether the overall appearance of a claimed design is dictated by functional considerations. *Id.*; *High Point*, 730 F.3d at 1315 (“Assessing these five factors *may* help determine whether a claimed design, as a whole, is ‘dictated by’ functional considerations.” Thus, while the *Berry Sterling* factors can provide useful guidance, an inquiry into whether a claimed design is primarily functional should begin with an inquiry into the existence of alternative designs.

Ethicon presented evidence of alternative ornamental designs that could provide the same or similar functionality of the underlying ultrasonic shears. For example, Ethicon’s expert testified that “there were many different designs that would function just as well” as the designs claimed in the Design Patents. Ethicon’s expert also identified multiple alternative designs for hand-held surgical devices in the prior art. Covidien’s expert admitted that other trigger designs, for example, would “work well” but “look different.” Indeed, Covidien does not contend on appeal that there are no alternatives to the claimed designs, but merely argues that such designs cannot be considered true alternatives because, as the district court found, they did not work “equally well” as the claimed designs.

The foregoing evidence does not support the district court’s grant of summary judgment that the claimed designs are primarily functional for two reasons. First, the district court’s determination that the designs did not work “equally well” apparently describes the preferences of surgeons for certain basic design concepts, not differences in functionality of the differently designed ultrasonic shears. For example, in supporting its conclusion that alternative designs “would not have worked as well” as the claimed design, the district court pointed to testimony that surgeons preferred ultrasonic shears

with certain basic design features like activation buttons on the front, rather than the rear of the device, “open” triggers, rather than closed or loop-style triggers, and forward positions, as opposed to other positions, for placement of the torque knob.

Second, to be considered an alternative, the alternative design must simply provide “the same or similar functional capabilities.” *Rosco*, 304 F.3d at 1378 (reversing functionality finding because alternative mirror designs could still provide a similar level of performance); *see also Seiko Epson Corp. v. Nu-Kote Intern., Inc.*, 190 F.3d 1360, 1368 (Fed. Cir. 1999) (explaining that to be patentable, there cannot only be one “possible ornamental form of the article that could perform its function”). Here, there is no dispute that the underlying ultrasonic shears could still function in the same manner with a differently-shaped open trigger, activation button, and torque knob, and different relative locations of the trigger, button, and torque knob. Indeed, Covidien identifies no evidence or testimony that the particular appearance and shape of the open trigger, torque knob, or activation button provided utilitarian advantages over other ornamental designs of those elements.

Further, the district court’s functionality inquiry used too high of a level of abstraction. Instead of focusing on whether the specific patented designs had a functional purpose—the continuously curved “U” shape of the open trigger having tapered handles with ends flaring outwards, the football-shape of the activation button, and the asymmetrically-fluted torque knob with a flat front face—the district court focused its *PHG* analysis on the functional characteristics that any design of an open trigger, button, and torque knob would have for the underlying ultrasonic shears.

For example, the district court supported its conclusion that the claimed designs were “primarily functional” using testimony from Ethicon witnesses that the chosen design was “the best design ergonomically” of those considered for Ethicon’s commercial product. This ergonomic choice, however, was not a choice between different open trigger designs, but rather between the concept of an open trigger and a thumb-ring or loop-shaped trigger. This same evaluation of an open trigger guided the district court’s determination that alternative designs would not have worked as well as an open trigger because surgeons preferred the chosen design to alternatives. And as discussed above, the surgeon-preferred design was not the specific patented design, but rather the general concept of an “open trigger” versus a “closed trigger” design.

Similarly, the district court found significant the fact that Ethicon applied for utility patents that included figures similar to those of the claimed designs. The district court noted that the utility patents described an “ergonomically formed” trigger with a proximal and distal portion having different lengths, a rounded button, and a fluted rotation knob. Again, however, the district court’s analysis focuses on the concepts of an open trigger, button, and torque knob, rather than the specifically claimed design



conceptions of those elements. Finally, the district court relied on Ethicon's advertisements for its commercial product touting the "intuitive controls" of the rounded button and torque knob that offered the "ergonomic benefit of 'minimal index finger repositioning' " and the "easy access" provided by the open trigger. These advertisements, however, tout the functional benefits of the general design concepts of the underlying elements rather than any functional benefits of the specific claimed designs.

Ethicon's Design Patents cover only the specific ornamental conceptions of the features shown in their figures, and not the general concepts of an open trigger, a rounded button, and a fluted torque knob oriented in some configuration as part of an ultrasonic surgical device. The analysis of whether Ethicon's patented designs are invalid as dictated by function must also be performed at a level of particularity commensurate with the scope of the claims. For functionality purposes, "it is relevant whether functional considerations demand only this particular design or whether other designs could be used, such that the choice of design is made for primarily aesthetic, non-functional purposes." The district court performed its functionality analysis at too high a level of abstraction, focusing on the general concepts of an open trigger, torque knob, and activation button rather than the ornamental designs adorning those elements.

Moreover, Covidien has not shown by clear and convincing evidence that no designs other than those claimed in the Design Patents allow the underlying ultrasonic shears to perform their intended function. Indeed, the evidence in the record leads to the opposite conclusion. We therefore conclude the district court clearly erred in finding that Ethicon's patented designs are dictated by functional considerations and are therefore invalid as primarily functional. Because Covidien has not met its burden of showing that the Design Patents are invalid as functional, we reverse the district court's grant of summary judgment of invalidity of the Design Patents for functionality.

2

Because the Design Patents are not invalid, we move to the district court's grant of Covidien's motion for summary judgment of noninfringement. The district court found the claimed trigger, torque knob, and activation button elements of the Design Patents to be "based on functional considerations." district court therefore construed each claim of the Design Patents to encompass "nothing," factoring out and removing every element from the scope of the claimed designs.

...

For purposes of validity . . . a design patent is invalid if its overall appearance is dictated by function, and therefore primarily functional. If the overall appearance of a claimed design is not primarily functional, the design claim is not invalid, even if certain

elements have functional purposes. The scope of that claim, however, must be limited to the ornamental aspects of the design, and does not extend to “the broader general design concept.” *OddzOn Prods., Inc. v. Just Toys, Inc.*, 122 F.3d 1396, 1405 (Fed. Cir. 1997).

*Richardson* involved a claim to the ornamental design of a multi-function carpentry tool that combined a hammer with a stud climbing tool and a crowbar. 597 F.3d at 1290. There was no dispute that several individual elements of the claimed design had functional purposes. In particular, a portion of the hammer head was flat to effectively deliver force to a struck object, the handle of the tool was elongated to provide leverage, the crowbar was at the end of the handle to reach into narrow spaces, and a jaw was located on the opposite end of the hammer head to allow the device to be used as a climbing step. These elements—which composed the entirety of the multi-function tool—had utility that had been known and used in the art for more than a century, and were thus outside the scope of the design claim. This did not mean, however, that the design claim had no scope. Rather, the claim was limited to the ornamental aspects of these functional elements. In particular, the scope of the claim encompassed, among other ornamental aspects, the shape of the hammer head, the diamond-shaped flare of the crowbar and the top of the jaw, the rounded neck, the undecorated handle, and the orientation of the crowbar relative to the head of the tool (which was not driven by functional considerations, unlike the orientation of the hammer head and crowbar at opposite ends of the handle). Thus, the design claim did not broadly protect a multi-function tool with a hammer, crowbar, handle, and claw, but only the specific ornamental aspects of that tool in the depicted configuration.

...

Here, the district court found that the “U”-shaped trigger, the torque knob, and the rounded button claimed in various combinations by the Design Patents are dictated by function. For example, the “U”-shaped trigger operates the clamping arm of the ultrasonic shears. Its “open” design allows the user to exert higher input forces by employing multiple fingers, thus lessening hand fatigue and strain. The torque knob and rounded button provide functional controls for the ultrasonic shears. Their placement relative to the trigger offers ergonomic access, and the fluted shape of the torque knob permits a user to operate the knob with one finger. We agree that the trigger, torque knob, and activation button elements of the underlying article have functional aspects. But the district court’s construction of the Design Patents to have no scope whatsoever fails to account for the particular ornamentation of the claimed design and departs from our established legal framework for interpreting design patent claims.

[T]he district court ignored the facts that the trigger has a particular curved design, the torque knob has a particular flat-front shape, and the activation button has a particular rounded appearance. Unlike the functionality inherent in the underlying articles

themselves, there is no evidence in the record, that any of the ornamental designs adorning those underlying articles are essential to the use of the article. Thus, although the Design Patents do not protect the general design concept of an open trigger, torque knob, and activation button in a particular configuration, they nevertheless have some scope—the particular ornamental designs of those underlying elements. We therefore vacate the district court’s construction that the Design Patents cover “nothing.” The scope of the Design Patents, although limited, encompasses the depicted ornamental aspects of certain combinations of the trigger, torque knob, and activation button elements of ultrasonic surgical shears, in specific relative positions and orientations.

3

Although the district court construed the claims of the Design Patents to have no scope, it performed, in the alternative, an infringement analysis of Covidien’s accused ultrasonic shears based on a construction of the claimed designs that retained the ornamental aspects of the underlying trigger, torque knob, and activation button elements. We can thus evaluate the district court’s alternative grant of summary judgment of noninfringement of the Design Patents, because the district court apparently performed this analysis using a correct construction of the claimed designs.

A design patent is infringed “if, in the eye of an ordinary observer, giving such attention as a purchaser usually gives, two designs are substantially the same, if the resemblance is such as to deceive such an observer, inducing him to purchase one supposing it to be the other.” *Egyptian Goddess*, 543 F.3d at 670 (quoting *Gorham Co. v. White*, 81 U.S. 511, 528 (1871)). As with utility patents, the patentee must prove infringement of a design patent by a preponderance of the evidence. Where the claimed and accused designs are “sufficiently distinct” and “plainly dissimilar,” the patentee fails to meet its burden of proving infringement as a matter of law. If the claimed and accused designs are not plainly dissimilar, the inquiry may benefit from comparing the claimed and accused designs with prior art to identify differences that are not noticeable in the abstract but would be significant to the hypothetical ordinary observer familiar with the prior art. *Id.*

Differences, however, must be evaluated in the context of the claimed design as a whole, and not in the context of separate elements in isolation. Where, as here, the claimed design includes several elements, the fact finder must apply the ordinary observer test by comparing similarities in overall designs, not similarities of ornamental features in isolation. An element-by-element comparison, untethered from application of the ordinary observer inquiry to the overall design, is procedural error.

After performing a side-by-side comparison between the claimed designs and the design of Covidien’s accused shears, the district court concluded there could be no

genuine dispute that the claimed and accused designs were plainly dissimilar because they “simply did not look alike except for the fact that both are hand-held surgical devices with open trigger handles.” The district court thus determined that even if the Design Patents had scope, the design of Covidien’s accused shears did not infringe any of the claimed designs.

The claimed and accused designs are depicted below:

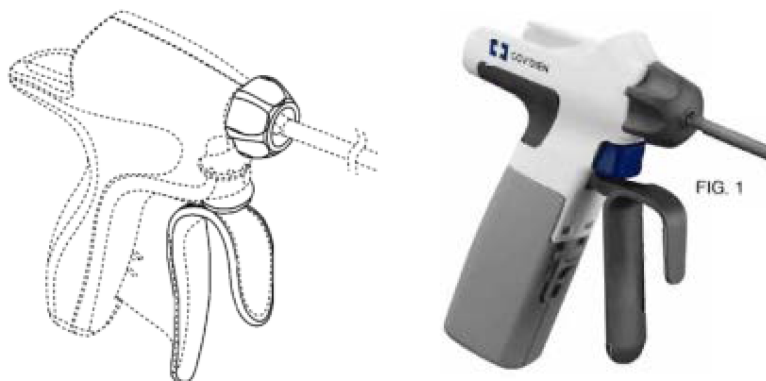

We agree with the district court that there is no genuine dispute the claimed and accused designs of an ultrasonic surgical device are plainly dissimilar. On a general conceptual level, both designs include an open trigger, a small activation button, and a fluted torque knob in relatively similar positions within the underlying ultrasonic device. Similarity at this conceptual level, however, is not sufficient to demonstrate infringement of the claimed designs. . . . [B]ecause each of these components has a functional aspect, the underlying elements must be excluded from the scope of the design claims at this general conceptual level. And when the remaining ornamental features of those components are compared, as a whole, to the corresponding ornamental features of Covidien’s accused ultrasonic surgical shears, the dissimilarities between the designs are plain.

The district court identified the most obvious difference between the claimed and accused designs as “the overall contoured shape” of the claimed design and the “overall linear shape” of the accused design. The district court also identified plain dissimilarities between the ornamentation of the trigger, torque knob, and button elements of the claimed and accused designs. For the trigger, the district court found dissimilarities between the proximal and distal portions of the claimed trigger handle, which curved toward and away from the device, respectively, and the proximal and distal portions of the accused trigger handle, which were parallel. The district court also found differences between the width and length of the proximal and distal handles of the claimed and

accused triggers, noting in particular that the proximal handle of claimed design was tapered at its end and at the portion connecting the proximal and distal handles, while the proximal handle of the accused design was a consistent width throughout. For the activation button, the district court found the football-shaped button of the claimed design and the rectangular button of the accused design to be dissimilar. As for the torque knob, the district court found dissimilarities between the unevenly-tapered flutes and flat front face with a large circular recess at its center of the claimed design, and the evenly-tapered flutes and rounded front face with no recess of the accused design. We find no error with the district court's determination that the claimed and accused designs are plainly dissimilar.

Ethicon does not challenge any of these specific findings by the district court, but instead asserts that the claimed and accused designs are not plainly dissimilar, and as a result, contends that the district court should have considered the frame of reference provided by the prior art, which Ethicon characterizes as predominantly featuring thumb-ring and loop-shaped triggers. However, comparing the claimed and accused designs with the prior art is beneficial only when the claimed and accused designs are not plainly dissimilar. Because the district court found the nonfunctional, ornamental aspects of the claimed and accused designs to be plainly dissimilar, it did not need to compare the claimed and accused designs with the prior art, as resolution of the infringement inquiry was already clear.

Ethicon also contends that the district court erred in identifying who the ordinary observer would be. The district court found the ordinary observer to be a sophisticated entity who managed the complex medical device purchasing process, because that entity was the ultimate purchaser of the underlying ultrasonic surgical shears. Ethicon argues that the ordinary observer is the surgeon who would use the shears.

The Supreme Court explained in *Gorham* that the ordinary observer is not an expert in the claimed designs, but one of "ordinary acuteness" who is a "principal purchaser" of the underlying articles with the claimed designs. Ethicon does not dispute that it is the hospital or medical device supplier, not the surgeon, who is ultimately responsible for purchasing the underlying articles at issue. Regardless, we see no need to resolve this dispute because Ethicon fails to explain how the infringement analysis would be affected if surgeons—who are more sophisticated than the general public—were considered to be the hypothetical ordinary observer. The claimed and accused designs are plainly dissimilar even to one less discerning than the ordinary observer; these distinctions would only be more evident to a sophisticated observer, whether a purchasing entity or a surgeon.

As the district court correctly concluded, the scope of the Design Patents "does not entitle Ethicon to preclude others from using all styles or placements of open triggers,

fluted rotation knobs, or activation buttons.” Rather, because these elements have functional purposes, the Design Patents protect only the ornamental designs adorning those elements, and not the general concept of an ultrasonic surgical device having an open trigger, a fluted knob, and a rounded button. Here, there can be no genuine dispute that at the proper level of granularity, the claimed ornamental designs of the Design Patents are, as a whole, plainly dissimilar from the ornamental design of Covidien’s accused ultrasonic shears. Therefore, we affirm the district court’s grant of summary judgment of noninfringement of the Design Patents.

We have considered the parties’ remaining arguments and find them unpersuasive.

### III

Because Covidien has not met its burden of showing that the ornamental designs claimed by the Design Patents are primarily functional, we reverse the district court’s grant of summary judgment of invalidity of the Design Patents. . . . The ornamental designs claimed by the Design Patents, however, are plainly dissimilar from the designs of Covidien’s accused ultrasonic shears. We thus affirm the district court’s alternative grant of summary judgment of noninfringement of the Design Patents. . . .

### Context & Application

1. Did you find *Ethicon’s* attempt to reconcile the court’s functionality precedents persuasive? Why or why not?

2. What is the status of the *Berry Sterling* factors post-*Ethicon*? What role do alternative designs play in the validity analysis? What counts as an alternative design?

3. *Ethicon* introduces us to a third facet of the ornamentality requirement—claim construction. Note that this type of functionality filtration is allowed, but not required, by *Egyptian Goddess*. What work is this kind of claim construction actually accomplishing? The court says that:

We agree with the district court that there is no genuine dispute the claimed and accused designs of an ultrasonic surgical device are plainly dissimilar. On a general conceptual level, both designs include an open trigger, a small activation button, and a fluted torque knob in relatively similar positions within the underlying ultrasonic device. Similarity at this conceptual level, however, is not sufficient to demonstrate infringement of the claimed designs. . . . [B]ecause each of these components has a functional aspect, the underlying elements must be excluded from the scope of the design claims at this general conceptual level. And when the remaining ornamental features of those components are compared, as a

## DESIGNS

whole, to the corresponding ornamental features of Covidien's accused ultrasonic surgical shears, the dissimilarities between the designs are plain.

What do you make of this passage? If all it means is that design patents protect how something looks, as opposed to how it works, then what does this "claim construction" add to the infringement analysis? Is anything really being "excluded from the scope of the claim" if the functionality was never covered to begin with?

4. Does "functionality" mean the same thing when the court is doing claim construction that it does when the court is analyzing validity? If not, is that a problem?

### D. Disclosure & Priority

Design patents are subject to the disclosure requirements of 35 U.S.C. § 112. But since design patent subject matter and claims are very different from utility patent subject matter and claims, the application of § 112 is also quite different. In design patents, the description is done primarily through drawings. *See* 37 C.F.R. § 1.153 ("No description, other than a reference to the drawing, is ordinarily required."); MPEP § 1503.02 ("[T]he drawing or photograph constitutes the entire visual disclosure of the claim . . ."). If the drawings in a design patent application are inconsistent with each other, the USPTO will reject the claim for lack of enablement and for indefiniteness. *See* MPEP § 1503.02. Some of the most important (and least developed) areas of design patent law involve § 112.

#### *In re Daniels*

144 F.3d 1452 (Fed. Cir. 1998)

NEWMAN, Circuit Judge.

Scott J. Daniels appeals the decision of the United States Patent and Trademark Office, Board of Patent Appeals and Interferences, wherein the Board determined that Mr. Daniels' design patent application was not entitled to the benefit of the filing date of an earlier copending design application, and thus that the subject matter was unpatentable for obviousness in view of an intervening publication.

On June 22, 1992 Mr. Daniels, through American Inventors Corporation, filed design patent application Serial No. 07/902,055 for a "leecher," a device for trapping leeches. The specification consisted of seven drawings, including top and bottom, and side views showing the leecher decorated on each side with a pattern of leaves, as in Fig. 1:

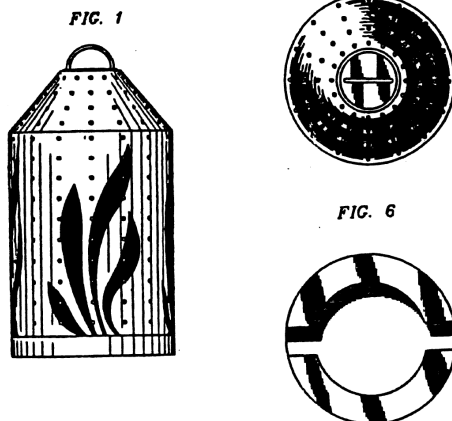

While the patent application was pending the Federal Trade Commission charged American Inventors Corporation with running a deceptive invention-promotion scheme. The Board reports the charges that American Inventors Corporation misled inventors by filing design patent applications instead of utility applications and concealing the differences between them. The Board describes evidence that clients were given a money-back guarantee that a patent would issue, and evidence that the Corporation's draftsman would add decorative matter to the drawings to facilitate issuance as a design patent.

On April 1, 1994 Mr. Daniels, through new counsel, filed a continuation design application under 37 C.F.R. § 1.62, Serial No. 29/020,787, and by amendment directed the PTO's Official Draftsman to delete the leaf pattern from the drawings. No other changes were made. The application thus contained drawings as shown below:

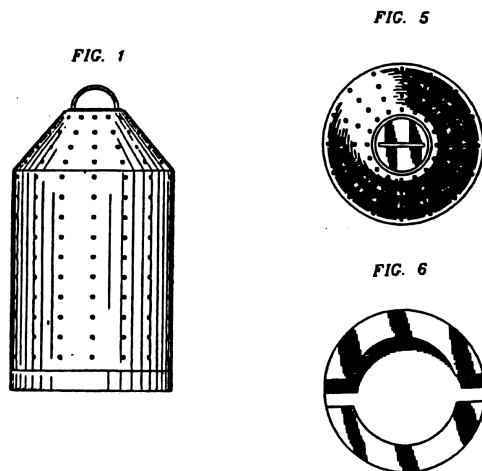



## DESIGNS

The examiner rejected the application in view of an intervening marketing brochure showing the leecher of the parent application. This rejection would be obviated if Mr. Daniels were entitled to the priority date of the parent application in accordance with 35 U.S.C. § 120:

An application for patent for an invention disclosed in the manner provided by the first paragraph of section 112 of this title in an application previously filed in the United States shall have the same effect, as to such invention, as though filed on the date of the prior application.

The Board, describing the question as one of first impression, denied Mr. Daniels the benefit of his parent application, holding that the leecher shown in the continuing application is a “new and different” design in that a design is “a unitary thing,” and thus that the change in the drawings defeats compliance with the written description requirement of the first paragraph of 35 U.S.C. § 112:

The specification shall contain a written description of the invention, and of the manner and process of making and using it, in such full, clear, concise, and exact terms as to enable any person skilled in the art to which it pertains, or with which it is most nearly connected, to make and use the same, and shall set forth the best mode contemplated by the inventor of carrying out his invention.

Mr. Daniels appeals, arguing that his parent application fully discloses the leecher design of the continuing application, and thus meets the requirements of § 112 ¶ 1.

### *Discussion*

Entitlement to priority under § 120 is a matter of law, and receives plenary review on appeal. *Racing Strollers, Inc. v. TRI Industries, Inc.*, 878 F.2d 1418, 1419, 11 U.S.P.Q.2d 1300, 1301 (Fed. Cir. 1989) (*en banc*). Any disputed factual questions are reviewed on the clearly erroneous standard.

The statutory provision governing the effective filing date of the subject matter of continuing applications, 35 U.S.C. § 120, applies to design patents as to utility patents. *See* 35 U.S.C. § 171 (“The provisions of this title relating to patents for inventions shall apply to patents for designs, except as otherwise provided”). It was confirmed in *Racing Strollers* that “there are no otherwise provided statutes to take design patent applications out of the ambit of § 120 which makes no distinction between applications for design patents and applications for utility patents.” 878 F.2d at 1421.

That the law of § 120 applies to design patent applications is illustrated in the court’s rulings that design and utility patents are each entitled to claim priority from the other. *See Racing Strollers*, 878 F.2d at 1418 (overruling contrary precedent and holding that a design patent may claim priority from a utility patent); *KangaROOS, U.S.A., Inc. v. Caldor*,

*Inc.*, 778 F.2d 1571, 1574 (Fed. Cir. 1985) (holding that a utility patent may claim priority from a design patent). The common thread, and the criterion to be met, is whether the later claimed subject matter is described in the earlier application in compliance with § 112 ¶ 1.

Thus the earlier application must meet the written description requirement of § 112. The test for sufficiency of the written description is the same, whether for a design or a utility patent. This test has been expressed in various ways; for example, “whether the disclosure of the application relied upon reasonably conveys to the artisan that the inventor had possession at that time of the later claimed subject matter.” When the earlier disclosure is less than clear on its face, courts have explained that the prior application must “necessarily” have described the later claimed subject matter. In general, precedent establishes that although the applicant “does not have to describe exactly the subject matter claimed, the description must clearly allow persons of ordinary skill in the art to recognize that the applicant invented what is claimed.”

It is the drawings of the design patent that provide the description of the invention. Although linguists distinguish between a drawing and a writing, the drawings of the design patent are viewed in terms of the “written description” requirement of § 112. Thus when an issue of priority arises under § 120, one looks to the drawings of the earlier application for disclosure of the subject matter claimed in the later application. *See Vas-Cath Inc. v. Mahurkar*, 935 F.2d 1555, 1563 (Fed. Cir. 1991); *Racing Strollers*, 878 F.2d at 1420. The inquiry is simply to determine whether the inventor had possession at the earlier date of what was claimed at the later date.

The leecher as an article of manufacture is clearly visible in the earlier design application, demonstrating to the artisan viewing that application that Mr. Daniels had possession at that time of the later claimed design of that article . . . . The leaf ornamentation did not obscure the design of the leecher, all details of which are visible in the drawings of the earlier application. The leaf design is a mere indicium that does not override the underlying design. The subject matter of the later application is common to that of the earlier application. In the context of 35 U.S.C. § 171 (“design for an article of manufacture” is the subject matter of a design patent), it is apparent that the earlier application contains a description of what is claimed in the later application.

The Board held that any change in the drawing defeats a priority claim for a design patent. Departing from the general rule that common subject matter is entitled to priority, the Board stated that a design is “a unitary thing,” and thus that when the design is changed it becomes a different design, and not subject to severance of any common subject matter for purposes of priority. . . .

The Board was incorrect in holding that any change in the design defeats a priority claim as a matter of law. As for any application asserting a priority claim, § 120 requires that the subject matter for which priority is requested must be disclosed in accordance with the requirements of § 112. A wealth of precedent guides the application of this statute. Applying the guidance of precedent, as we have discussed, the later claimed subject matter is contained in the earlier application. The leaf ornamentation in the parent application, superimposed upon the design of the leecher itself, does not obscure that design, which is fully shown in the parent application drawings. On the correct law, it must be concluded that Mr. Daniels possessed the invention that is claimed in the continuation application, and that he is entitled to claim priority under § 120.

Mr. Daniels is entitled to the parent application's filing date for the subject matter of the continuation, thus obviating the rejection based on the intervening publication. The Board's decision is reversed.

### Context & Application

1. The court mentions that the company that filed Daniels' first patent application, American Inventors Corporation (AIC), was sued by the Federal Trade Commission (FTC) for "running a deceptive invention-promotion scheme." The U.S. District Court for the District of Massachusetts granted a preliminary injunction against AIC. The court prohibited AIC from, among other things, "making, directly or by implication, any material false or misleading oral or written statement or representation in connection with providing services, for a fee, purportedly to patent, market, or promote individual inventions into commercial success, including, but not limited to, any misrepresentation: . . . That the patents defendants seek and obtain have commercial value." *FTC v. Am. Inventors Corp.*, 1995 WL 768924, at \*1-2 (D. Mass. Nov. 16, 1995).

This was not the only enforcement action filed against unscrupulous invention-submission companies during that period. See Lynn A. Bristol, *Invention Disclosure Services: Needed Change for A Needed System*, 80 J. PAT. & TRADEMARK OFF. SOC'Y 753, 757-58 (1998) (citing "numerous FTC and state actions" filed between 1977 and 1997). One popular tactic for these companies was to offer to obtain "patents," letting inventors assume they meant *utility* patents, then file for a cheaper, narrower, design patent instead. See generally *id.* at 766 n.60 ("A design patent application is easier (thus, less costly) to draft than a utility application, and because of its limited scope of protection, relatively easy to get. It is also less valuable commercially because of its limited scope."). And, at least based on the facts in *Daniels*, it appears that these companies didn't always understand how design patents really worked—see, e.g., the unnecessary addition of the leaf surface motif. In any case, this type of invention-submission scheme has given design patents a bad

reputation among some patent prosecutors. While that's understandable given this history, do you think design patents really deserve such a bad rap? Can you see any circumstances where design patent protection might be preferable to utility patent protection? Also, do you think the fact that Daniels was a victim of this kind of scheme influenced the outcome of his case?

2. Remember that there are three longstanding types of designs—configuration (a/k/a shape) designs, surface ornamentation designs, and combination designs. What type of design was claimed in Daniels' original application? In the continuation application? Should that have affected or influenced the court's analysis of the written description issue?

3. In *Daniels*, the court said that "precedent establishes that although the applicant does not have to describe exactly the subject matter claimed, the description must clearly allow persons of ordinary skill in the art to recognize that the applicant invented what is claimed," citing cases decided before the Federal Circuit's *en banc* decision in *Ariad Pharm., Inc. v. Eli Lilly & Co.*, 598 F.3d 1336 (Fed. Cir. 2010). Does anything in *Ariad* suggest or require a change in design patent written-description doctrine? In *Ariad*, the court said:

The term "possession," however, has never been very enlightening. It implies that as long as one can produce records documenting a written description of a claimed invention, one can show possession. But the hallmark of written description is disclosure. Thus, "possession as shown in the disclosure" is a more complete formulation. Yet whatever the specific articulation, the test requires an objective inquiry into the four corners of the specification from the perspective of a person of ordinary skill in the art. Based on that inquiry, the specification must describe an invention understandable to that skilled artisan and *show that the inventor actually invented the invention claimed*.

598 F.3d at 1351 (emphasis added). Is *Daniels'* visibility test consistent with this statement from *Ariad*? If someone claims a combination design, does that necessarily mean that they also invented the shape? The surface design?

4. As noted above, today, design patent applicants can claim less than the whole shape and/or surface design in a design patent by using broken lines to indicate disclaimed subject matter. See *In re Zahn*, 617 F.2d 261 (C.C.P.A. 1980). See also MPEP § 1504.04(C) ("The scope of a design claim is defined by what is shown in full lines in the application drawings.") (citing *Contessa Food Prods., Inc. v. Conagra, Inc.*, 282 F.3d 1370, 1378 (Fed. Cir. 2002)). They can also use dot-dash lines to indicate unclaimed boundary lines. How should these claiming conventions affect the law or policy of design patent written description? The next case touches on some of these issues.

DESIGNS

*In re Owens*

710 F.3d 1362 (Fed. Cir. 2013)

PROST, Circuit Judge.

Timothy S. Owens, et al. (“Owens”) appeal a decision of the United States Patent and Trademark Office . . . affirming a rejection of his design patent application, U.S. Design Patent Application No. 29/253,172 (“’172 application”). . . .

I

The ’172 application, which is the subject of this appeal, is a continuation of U.S. Design Patent Application No. 29/219,709 (filed Dec. 21, 2004) (“’709 application”). The ’709 application claimed a design for a bottle with boundaries set forth in the figures below:

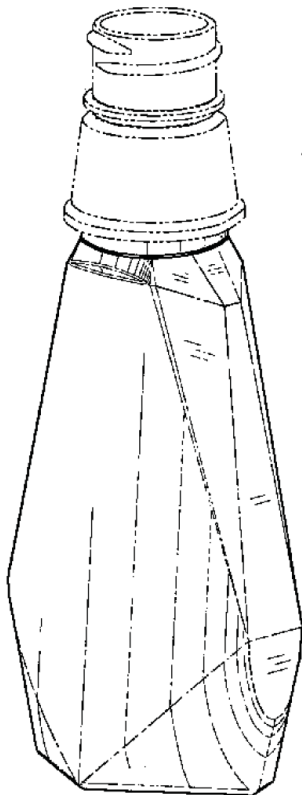

FIG. 1

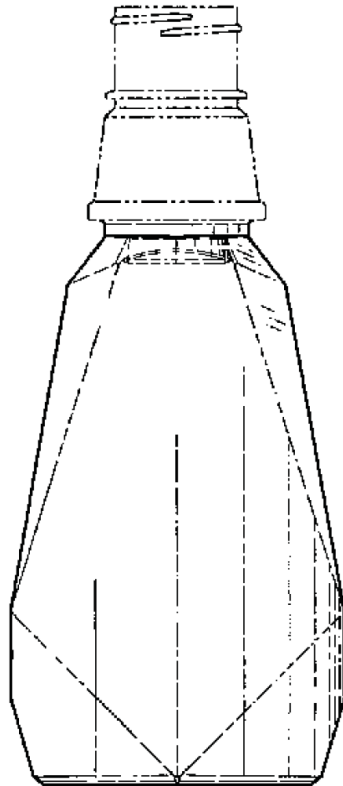

FIG. 2

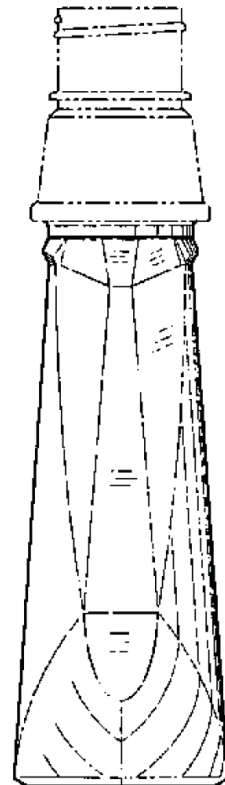

FIG. 3

## CHAPTER 12

The '709 application ultimately issued as U.S. Design Patent No. D531,515 (issued Nov. 7, 2006) ("515 patent"), and that issuance is not contested here.

Owens then filed the '172 application in 2006, seeking the benefit of the '709 application's 2004 priority date under 35 U.S.C. § 120. Owens conceded during prosecution that, if denied the earlier effective filing date, the '172 application would be unpatentable because he had sold bottles embodying his design more than one year before filing his continuation.

The '172 application claimed certain design elements found on the top and side portions of the original bottle, as depicted in Figures 1 through 3:

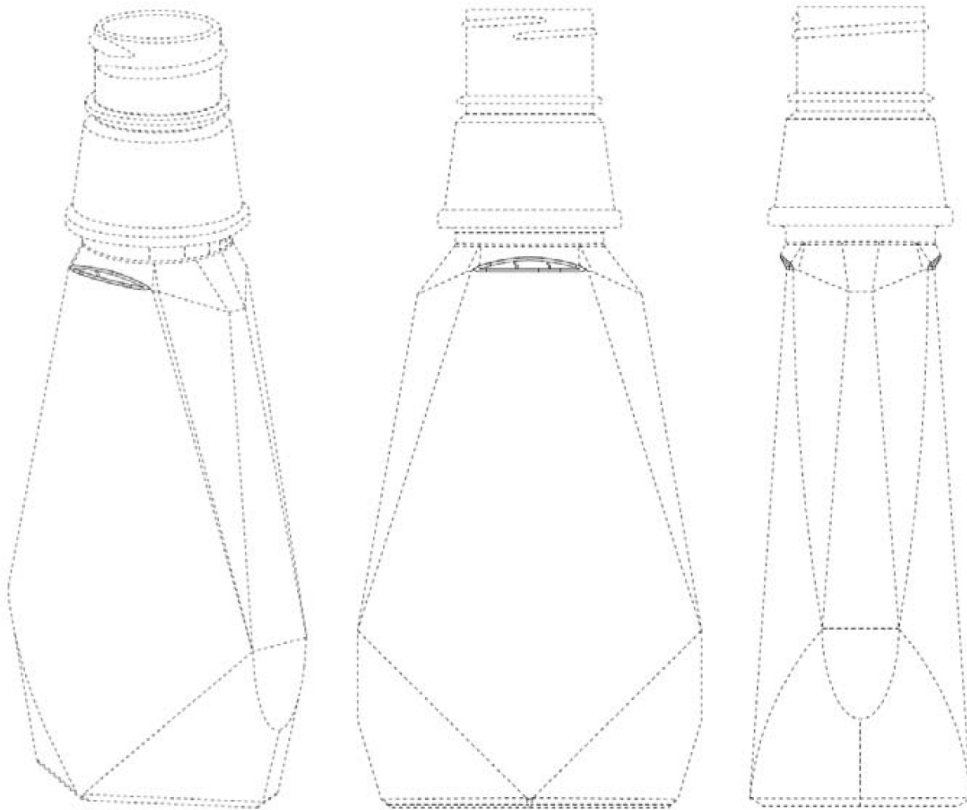

FIG. 1

FIG. 2

FIG. 3

In particular, the '172 application claimed three design elements: (1) the small crescent-shaped area on the front and back of the bottle near the cap; (2) the narrow triangular areas along the bottle's "shoulders;" and (3) an upper portion of the bottle's pentagonal

## DESIGNS

center panel. To indicate what portion of the center area was claimed, Owens bisected the top of his pentagonal panel with a broken line.

The examiner rejected the '172 application. The basis for the rejection was the addition of the broken line, which the examiner understood as defining an entirely new "trapezoidal"-shaped surface that was considered new matter:

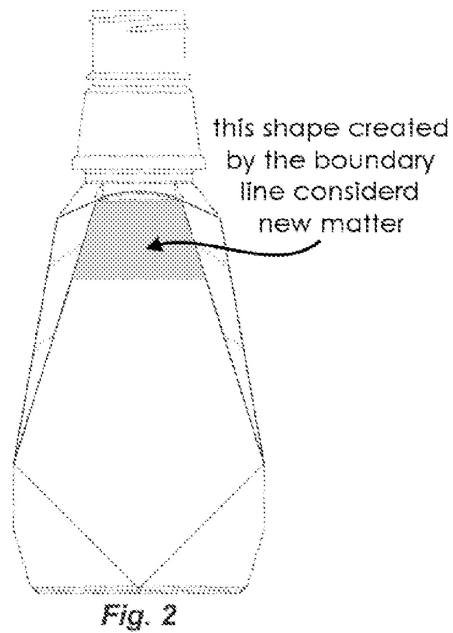

The examiner found no evidence that Owens originally possessed such a trapezoidal region in the '709 application. As such, the examiner rejected the '172 application for lack of written description under 35 U.S.C. § 112, ¶ 1, and furthermore rejected the application as unpatentably obvious in view of the earlier-sold bottles under 35 U.S.C. § 103(a).

Owens appealed to the Board, which noted at the outset that the correctness of the examiner's § 103(a) rejection depended on whether the '172 application was entitled to the benefit of the '709 application's filing date. That issue, in turn, hinged on whether the '709 application contained a written description sufficient to convey to an ordinary designer that Owens possessed the subject matter of the '172 application as of the earlier filing date.

Addressing the latter question, the Board focused upon the difference between the parent and the continuation's front panels—namely, the continuation's introduction of a broken line bisecting the parent's pentagonal front panel. Like the examiner, the Board understood this to indicate that Owens had claimed previously undisclosed "trapezoidal sections occupying part, but not all, of the surface area of the front and back panels." Accordingly, the Board affirmed the examiner's rejections.

## CHAPTER 12

Owens timely appealed, and we have jurisdiction under 28 U.S.C. § 1295(a)(4)(A) and 35 U.S.C. § 141.

### II

The statutory provision governing the effective filing date of the subject matter of continuing applications, 35 U.S.C. § 120, applies generally to design patents as well as utility patents. *See* 35 U.S.C. § 171. Entitlement to priority under § 120 is a matter of law which we review de novo.

To be entitled to a parent's effective filing date, a continuation must comply with the written description requirement of 35 U.S.C. § 112, ¶ 1. 35 U.S.C. § 120; *Daniels*, 144 F.3d at 1456. . . .

The test for sufficiency of the written description, which is the same for either a design or a utility patent, has been expressed as "whether the disclosure of the application relied upon reasonably conveys to those skilled in the art that the inventor had possession of the claimed subject matter as of the filing date." In the context of design patents, the drawings provide the written description of the invention. Thus, when an issue of priority arises under § 120 in the context of design patent prosecution, one looks to the drawings of the earlier application for disclosure of the subject matter claimed in the later application.

### III

The subject of this appeal is the broken line that Owens introduced in his continuation application. The parties agree that the parent application discloses no boundary that corresponds (either explicitly or implicitly) to this newly-added broken line. However, the parties also agree that a design patentee may, under certain circumstances, introduce via amendment a straight broken line without adding new matter, even "where no corresponding boundary line is shown in a design application as originally filed." MPEP § 1503.02.

The parties refer to these broken-line boundaries as "unclaimed boundary" lines because the lines are "not intended to form part of the claimed design" and do "not exist in reality in the article embodying the design." Rather, when an unclaimed boundary line is introduced via amendment or continuation, it is "understood that the claimed design extends to the unclaimed boundary but does not include the unclaimed boundary."

In other words, when an unclaimed boundary line divides a previously claimed area, it indicates that the applicant has disclaimed the portion beyond the boundary while claiming the area within it. Where permissible, unclaimed boundary lines allow the patentee to adjust his patent coverage and encompass embodiments that differ slightly but insignificantly from the originally-filed design. However, like all amendments made



## DESIGNS

during prosecution, these lines must comply the written description requirement to receive the benefit of priority under § 120.

### IV

Bearing all of this in mind, we turn to the merits of Owens's case. The Board rejected the '172 application because it believed that, as a prerequisite to patentability, Owens needed to demonstrate prior possession of a bottle with a trapezoidal section occupying part, but not all, of the surface area of the center-front panel. Owens made no such showing before the Board, nor does he do so on appeal.

Instead, Owens attacks the very notion that his continuation claims a trapezoidal-shaped area at all. Owens insists that in order to claim a new design element, one must first claim a new boundary. Yet his newly introduced broken line is, as all parties agree, "unclaimed." Accordingly, he believes the Board applied the wrong written description test to his case, one which erroneously treated his unclaimed boundary as though it was claimed.

Owens suggests a more relaxed written description test for these circumstances based upon his interpretation of *In re Daniels*. In that case, we held that a continuation application claiming a design for a container was entitled to the effective filing date of its parent application, which claimed the same container decorated with an ornamental floral design. We reasoned that the underlying container claimed in the continuation was "clearly visible in the earlier design application, demonstrating to the artisan viewing that application that Mr. Daniels had possession at that time of the later claimed design of that article."

Owens believes his amendment satisfies the Daniels test because all portions of his pentagonal front panel were "clearly visible" in the '709 application. His argument is premised on the notion that an applicant who has possession of an entire area in a parent application must likewise possess all parts of the area. He therefore believes he should now be permitted to disclaim any portion of his original design in a continuation and still survive the written description test.

Owens misconstrues our holding in *Daniels*. The patentee in *Daniels* did not introduce any new unclaimed lines, he removed an entire design element. It does not follow from *Daniels* that an applicant, having been granted a claim to a particular design element, may proceed to subdivide that element in subsequent continuations however he pleases.

Moreover, the written description question does not turn upon what has been disclaimed, but instead upon whether the original disclosure "clearly allows persons of ordinary skill in the art to recognize that the inventor invented what is claimed." *Ariad*, 598 F.3d at 1351; *Daniels*, 144 F.3d at 1456 ("The written description inquiry is simply to

determine whether the inventor had possession at the earlier date of what was claimed at the later date.”). In this case, Owens’s parent application discloses a design for a bottle with an undivided pentagonal center-front panel, whereas the continuation claims only the trapezoidal top portion of that center-front panel. Therefore, the question for written description purposes is whether a skilled artisan would recognize upon reading the parent’s disclosure that the trapezoidal top portion of the front panel might be claimed separately from the remainder of that area. *Ariad*, 598 F.3d at 1351.

The Board answered this factual question in the negative, finding that nothing in the parent application’s disclosure suggested anything uniquely patentable about the top portion of the bottle’s front panel. This finding is supported by substantial evidence . . . . Accordingly, we must affirm the Board’s decision.

## V

Lastly, we turn to a question raised implicitly in Owens’s appeal and explicitly in amicus briefing—whether, and under what circumstances, Owens could introduce an unclaimed boundary line on his center-front panel and still receive the benefit of § 120.

The Manual of Patent Examining Procedure (“MPEP”) provides some direction in this regard, saying that unclaimed boundary lines “may” be acceptable when “connecting the ends of existing full lines.” MPEP § 1503.02. Were this the rule, it might be acceptable for Owens to bisect his front panel with a broken line along the pentagon’s widest point. However, it seems that such a boundary would simply outline a larger trapezoidal area, and so the resulting claim would suffer from the same written description problems as the ’172 application.

Prior PTO practice offers similarly ambiguous guidance. For instance, the amicus brief noted certain past allowances that seemingly contradict both the MPEP and the PTO’s rejection of the Owens continuation.

In our view, the best advice for future applicants was presented in the PTO’s brief, which argued that unclaimed boundary lines typically should satisfy the written description requirement only if they make explicit a boundary that already exists, but was unclaimed, in the original disclosure. Although counsel for the PTO conceded at oral argument that he could not reconcile all past allowances under this standard, he maintained that all future applications will be evaluated according to it.

This rule comports with our understanding of how unclaimed boundary lines generally should affect entitlement to an earlier filing date under § 112, ¶ 1, and § 120. Its implications for Owens’s case should be obvious.

*Conclusion*

For the reasons set forth above, we affirm the Board’s rejection of the ’172 application.

## Context & Application

1. Following *Owens*, when can an applicant add dot-dash boundary lines without running afoul of the prohibition on adding new matter?

2. What about the other kind of dotted lines, the ones that indicate something that is “no part of the claimed design”? See MPEP § 1503.02(III). The USPTO says that “an amendment that changes the scope of a design by either converting originally-disclosed solid line structure to broken lines or converting originally-disclosed broken line structure to solid lines would not introduce new matter because such amendment would not introduce subject matter that was not originally disclosed.” MPEP § 1504.04(B). Does this rule make sense? If someone creates a design for a new shape for a whole bottle and claimed that new shape using all solid lines, would you assume that person had also invented every line or curve that made up the shape of the bottle? Every part or portion of the claimed bottle shape?

3. In *Owens*, the court says—without any citation or support—that “[w]here permissible, unclaimed boundary lines allow the patentee to adjust his patent coverage and encompass embodiments that differ slightly but insignificantly from the originally-filed design.” What do you make of this statement? Is the court trying to describe contemporary USPTO practice? Or is this language proscriptive?

4. In *Owens*, the court says that:

Owens misconstrues our holding in *Daniels*. The patentee in *Daniels* did not introduce any new unclaimed lines, he removed an entire design element. It does not follow from *Daniels* that an applicant, having been granted a claim to a particular design element, may proceed to subdivide that element in subsequent continuations however he pleases.

What is the court concerned about here? And in this context, what do you think the court means by a “design element”?

5. A design patent lasts “for the term of 15 years *from the date of grant*.” 35 U.S.C. § 173 (emphasis added). This means that an applicant could file multiple related application, changing dotted lines to solid lines (or *vice versa*) to change the scope of the claim and end up with more than 15 years of protection for a single product. Is this a good system? The term of a utility patent used to be calculated the same way. As Mark Lemley has explained:

In 1994, Congress enacted the most significant change in the patent laws in over forty years. . . . Under the old law, patentees received a fixed term of protection of seventeen years from the day the patent issued. That fixed term has been changed to a variable term not to exceed twenty years. Specifically, beginning on June 8,

## CHAPTER 12

1995, the patent term will extend from the day a patent is issued by the [PTO] until twenty years from the day the patent application was filed with the PTO.

*An Empirical Study of the Twenty-Year Patent Term*, 22 AIPLA Q.J. 369, 370 (1994). Why did Congress change the rule for calculating utility patent terms?

One of the primary issues driving the twenty-year term was the problem of “submarine patents.”

Submarine patents are applications filed by inventors who keep their application pending in the PTO for a long period of time. Sometimes this delay on the part of the inventor is intentional-by delaying the issuance of their patent, these inventors hope to take the industry by surprise, announcing a new patent which all the participants in a mature market must license. Delay resulting from multiple abandonment and refiling need not be intentional to cause problems, however. Because the owner of the submarine patent will be able to claim priority to his initial application, he will presumably be able to demonstrate that he was the first inventor of the new technology. Under the patent laws, the patentee has the right to prevent all others from making, using, offering for sale, selling or importing the invention. It does not matter that the defendant developed the technology independently or before the patent issued.

*Id.* at 376–77. Do you think submarine patents are likely to be a problem (or as much of a problem) in the context of design patents? Are there any other reasons you can think of for calculating design patent terms based on their issue dates instead of their effective filing dates?

### *In re Maatita*

900 F.3d 1369 (Fed. Cir. 2018)

DYK, Circuit Judge.

This is an appeal from a rejection in initial examination of appellant Ron Maatita’s design patent application covering the design of an athletic shoe bottom. The examiner rejected the application’s single claim as non-enabled and indefinite under 35 U.S.C. § 112 because it used a single, two-dimensional plan-view drawing to disclose a shoe bottom design and thereby left the design open to multiple interpretations regarding the depth and contour of the claimed elements. The Patent Trial and Appeal Board (“Board”) affirmed the examiner’s rejection. Because we find the Board misapplied § 112 in the design patent context, we reverse.

## DESIGNS

### *Background*

On October 24, 2011, Appellant Ron Maatita (“Maatita”) filed design patent application, No. 29/404,677 covering the design of an athletic shoe bottom. The application contained a single claim reciting “[t]he ornamental design for a Shoe Bottom as shown and described” and two figures showing a plan view of the claimed shoe bottom design. Figure 1 is reproduced below:

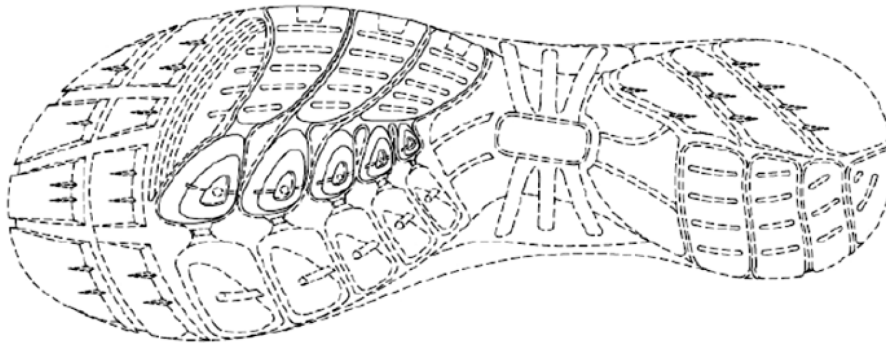

As is customary, the solid lines of Figure 1 show the claimed design, whereas the broken lines show structure that is not part of the claimed design—in this case, the shoe bottom environment in which the design is embodied. . . .

On February 4, 2014, the examiner . . . . rejected Maatita’s design claim as failing to satisfy the enablement and definiteness requirements of 35 U.S.C. § 112, first and second paragraphs. In the examiner’s view, the application’s use of a single, two-dimensional plan view to disclose a three-dimensional shoe bottom design left the design open to multiple interpretations regarding the depth and contour of the claimed elements, therefore rendering the claim not enabled and indefinite.

On May 1, 2014, Maatita responded to the office action, amending the specification to clarify that Figure 1 and Figure 2 represented the same embodiment in different environmental settings. Maatita also argued that there was no enablement problem because “there is no specific allegation that one of ordinary skill would not be able to produce the claimed design, i.e., that such a person would be incapable of selecting an appropriate depth or contour that would result in the illustrated combination of design features.” Moreover, in Maatita’s view, “omission of certain design elements that potentially could have been included merely affects the breadth of the claimed design.” Thus, the single claim could cover multiple appropriate depth and contour choices without rendering the claim indefinite. . . .

## CHAPTER 12

On May 13, 2014, the examiner issued a final rejection, again rejecting the claim as not enabled and indefinite. The examiner prepared and included four three-dimensional renderings showing different implementations of Maatita's two-dimensional plan view. These different implementations are shown below, as reproduced in the final written decision:

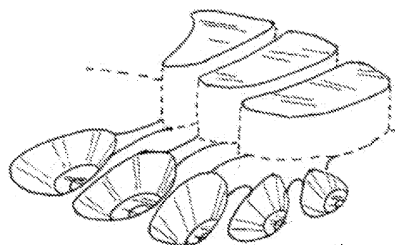

*In this attempt to apply Appellant's design, the designer has guessed that the three elements at the edge of the sole are raised and the five oval elements are recessed with flat centers.*

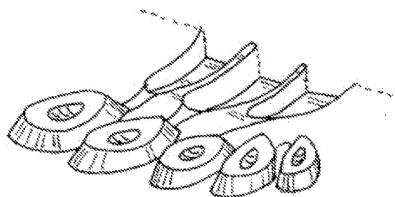

*In this attempt to apply Appellant's design, the three elements at the edge of the sole are recessed and the five oval elements are raised with concave centers.*

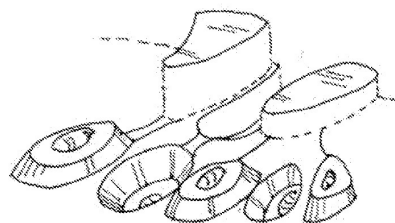

*In this attempt to apply Appellant's design, alternating elements are raised and recessed with the centers of the five oval elements having convex appearances.*

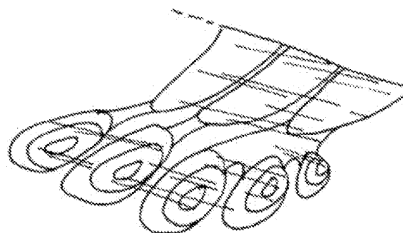

*A less imaginative interpretation of the claim would have a designer applying Appellant's design as an image on a flat surface in a single plane with the rest of the bottom surface.*

In the examiner's view, these four renderings were patently distinct and therefore could not be covered by a single claim. Thus, Maatita's single claim was indefinite and not enabled, "as one would not know which of the many possible distinct embodiments of the claim is applicant's in order to make and use applicant's design." Specifically, the

## DESIGNS

examiner noted that the claim was not enabled “because the disclosed design is not understandable to a designer of ordinary skill in the art without resorting to conjecture.” Similarly, the examiner found the claim indefinite “because the scope of protection sought is not disclosed in the specification or understandable as depicted in the drawings.”

. . . Maatita appealed the final rejection to the Board. . . . The Board concluded that “because the single view does not adequately reveal the relative depths and three dimensionality between the surfaces provided, the Specification does not reveal enough detail to enable the claimed shoe bottom, under 35 U.S.C. § 112, first paragraph,” and that “[t]he same lack of clarity and detail also makes the scope of the claim indefinite under 35 U.S.C. § 112, second paragraph.”

### *Discussion*

As with utility patents, the written description of a design patent must meet certain statutory requirements regarding enablement and definiteness. See 35 U.S.C. § 171. The pre-AIA version of 35 U.S.C. § 112, first paragraph, concerns the requirement that a patent be enabled by its written description. It states, in relevant part:

The specification shall contain a written description of the invention, and of the manner and process of making and using it, in such full, clear, concise, and exact terms as to enable any person skilled in the art to which it pertains, or with which it is most nearly connected, to make and use the same.

35 U.S.C. § 112. The second paragraph of § 112 addresses the definiteness requirement. It provides that:

The specification shall conclude with one or more claims particularly pointing out and distinctly claiming the subject matter which the applicant regards as his invention.

Because design patent claims are limited to what is shown in the application drawings, *see In re Mann*, 861 F.2d 1581, 1582 (Fed. Cir. 1988), there is often little difference in the design patent context between the concepts of definiteness (whether the scope of the claim is clear with reasonable certainty) and enablement (whether the specification sufficiently describes the design to enable an average designer to make the design), *see Ex Parte Asano*, 201 U.S.P.Q. 315, 317 (B.P.A.I. 1978) (explaining that issues related to enablement were “generally the same as” issues concerning definiteness in the design patent context); MPEP 1504.04 (I)(A). In this case, in particular, we think that the indefiniteness and enablement inquiries are similar and can be assessed together.

A visual disclosure may be inadequate—and its associated claim indefinite—if it includes multiple, internally inconsistent drawings. Errors and inconsistencies between

drawings do not merit a § 112 rejection, however, if they “do not preclude the overall understanding of the drawing as a whole.”

It is also possible for a disclosure to be inadequate when there are inconsistencies between the visual disclosure and the claim language. Ultimately, a patent is indefinite for § 112 purposes whenever its claim, read in light of the visual disclosure (whether it be a single drawing or multiple drawings), “fails to inform, with reasonable certainty, those skilled in the art about the scope of the invention.” See *Nautilus, Inc. v. Biosig Instruments, Inc.*, 572 U.S. 898(2014).

Here, we are not dealing with inconsistencies in the drawings, or inconsistencies between the drawings and the verbal description, but rather with a single representation of a design that is alleged to be of uncertain scope. The question is whether the disclosure sufficiently describes the design. In *Nautilus*, which dealt with indefiniteness in the utility patent context, the Supreme Court emphasized that § 112 ¶ 2 “requires that a patent’s claims, viewed in light of the specification and prosecution history, inform those skilled in the art about the scope of the invention with reasonable certainty.” The Court further explained that § 112’s definiteness requirement guards against “zones of uncertainty” within the patent system, “which enterprise and experimentation may enter only at the risk of infringement claims.” The purpose of § 112’s definiteness requirement, then, is to ensure that the disclosure is clear enough to give potential competitors (who are skilled in the art) notice of what design is claimed—and therefore what would infringe.

With this purpose in mind, it is clear that the standard for indefiniteness is connected to the standard for infringement. In the design patent context, one skilled in the art would look to the perspective of the ordinary observer since that is the perspective from which infringement is judged. A design patent is infringed if “an ordinary observer, familiar with the prior art, would be deceived into thinking that the accused design was the same as the patented design.” Given that the purpose of indefiniteness is to give notice of what would infringe, we believe that in the design patent context, one skilled in the art would assess indefiniteness from the perspective of an ordinary observer. Thus, a design patent is indefinite under § 112 if one skilled in the art, viewing the design as would an ordinary observer, would not understand the scope of the design with reasonable certainty based on the claim and visual disclosure.

...

... [T]he government argues that Maatita’s claim is indefinite because the design, as disclosed in the single, two-dimensional plan or planar view, could be applied to a three-dimensional shoe bottom in a number of ways. Specifically, the shapes specified by Maatita’s design could be flat, concave, convex, or some combination thereof. In Maatita’s view, the “relative depths and three dimensionality between the surfaces,” are not part of



the claimed design at all, and the differences between the possible three-dimensional implementations of his design are simply differences in unclaimed subject matter, *see* MPEP § 1504.04 (“When visible portions of the article embodying the design are not shown, it is because they form no part of the claim to be protected”).

In situations like this, where the sufficiency of a disclosure for purposes of § 112 depends on whether a drawing adequately discloses the design of an article, we believe that the level of detail required should be a function of whether the claimed design for the article is capable of being defined by a two-dimensional, plan- or planar-view illustration. The design for an entire shoe or teapot, for instance, is inherently three-dimensional and could not be adequately disclosed with a single, plan- or planar-view drawing. Whether an article infringed would depend on the perspective chosen to view the article, and a two-dimensional drawing provides no fixed perspective for viewing an article. The article would be infringing from one perspective but not from another. The design of a rug or placemat, on the other hand, is capable of being viewed and understood in two-dimensions through a plan- or planar-view illustration, which clearly defines the proper perspective. *See Ex Parte Salsbury*, 38 U.S.P.Q. 149, 1938 WL 28182, at \*2 (Com’r Pat. & Trademarks May 5, 1938) (“It is recognized that flat articles can generally be sufficiently illustrated by a single view.”). Such a claim, with a single drawing, would cover all similarly designed rugs or mats, even if one might have a low pile and the other a high pile (for a rug) or might be woven or textured fabric (for a placemat).

The government emphasizes that a shoe bottom is a three-dimensional article rather than a two-dimensional “ornament, impression, print, or picture to be applied to an article of manufacture,” and argues that the surface depths of a shoe bottom impact the visual impression of the design. The government is correct that a shoe sole is typically three-dimensional, with treads that may be convex or concave. And, indeed, many shoe bottom designers choose to claim their designs in a three dimensional fashion. But the fact that shoe bottoms can have three-dimensional aspects does not change the fact that their ornamental design is capable of being disclosed and judged from a two-dimensional, plan- or planar-view perspective—and that Maatita’s two-dimensional drawing clearly demonstrates the perspective from which the shoe bottom should be viewed. A potential infringer is not left in doubt as to how to determine infringement. In this case, Maatita’s decision not to disclose all possible depth choices would not preclude an ordinary observer from understanding the claimed design, since the design is capable of being understood from the two-dimensional, plan- or planar-view perspective shown in the drawing.

We do not, of course, suggest that an applicant for a design of a shoe bottom could not choose to disclose his design from a three-dimensional perspective, as many do. If so, that

## CHAPTER 12

would be the scope of the claimed design for purposes of judging obviousness, indefiniteness, or infringement. That is not what *Maatita* has done here.

### *Conclusion*

Because a designer of ordinary skill in the art, judging *Maatita*'s design as would an ordinary observer, could make comparisons for infringement purposes based on the provided, two-dimensional depiction, *Maatita*'s claim meets the enablement and definiteness requirements of § 112. We therefore reverse the decision of the Board.

### Context & Application

1. After *Maatita*, when is a design claim invalid as indefinite?
2. In *Maatita*, the Federal Circuit analogizes the claimed shoe-sole shape design to a design for the surface ornamentation of a rug:

Whether an article infringed would depend on the perspective chosen to view the article, and a two-dimensional drawing provides no fixed perspective for viewing an article. The article would be infringing from one perspective but not from another. The design of a rug or placemat, on the other hand, is capable of being viewed and understood in two-dimensions through a plan- or planar-view illustration, which clearly defines the proper perspective. Such a claim, with a single drawing, would cover all similarly designed rugs or mats, even if one might have a low pile and the other a high pile (for a rug) or might be woven or textured fabric (for a placemat).

Is this a persuasive analogy for sneaker soles? Why or why not?

3. Do you agree with the Federal Circuit that all the variants illustrated by the examiner were directed to the same design? Or was the examiner correct to conclude those were different shapes and thus patentably distinct?

## 13. POST-GRANT PROCEEDINGS

The involvement of the USPTO does not end once a patent is granted. There are a number of post-grant administrative proceedings that can result in alteration or even invalidation of an issued patent. One example is that patent owners may go back to the USPTO to disclaim certain claims of a patent or to correct errors. 35 U.S.C. §§ 253, 255. In 1980, Congress established “ex parte reexamination.” Ex parte reexamination permits “[a]ny person at any time” to “file a request for reexamination.” 35 U.S.C. § 302. If the Director determines that there is “a substantial new question of patentability” for “any claim of the patent,” the USPTO can open a reexamination. 35 U.S.C. §§ 303(a), 304.

But post-grant proceedings play a much larger role in current patent practice than they did prior to passage of the AIA. This is because the AIA introduced proceedings that make it much easier to challenge issued patents at the PTO. These include a post-grant review (PGR) process, which allow third party challenges to a patent’s validity on any basis that could be challenged in district court in the nine months after issuance. Once nine months have passed, the inter partes review (IPR) process allows for third party challenges to validity for failure to meet the novelty or nonobviousness requirements.

These proceedings have proven appealing to accused infringers in the federal district courts, who increasingly choose to resolve validity issues at the PTAB while federal litigation is stayed. Proceedings before the PTAB are likely appealing for their low cost, speed, and potentially from the expertise of PTAB judges. In any event, appeals from the PTAB make up a growing portion of the docket at the Federal Circuit. *See* Timothy B. Dyk, *Federal Circuit Jurisdiction: Looking Back and Thinking Forward*, 67 AM. U. L. REV. 971, 972–73 (2018) (“When I joined the court in 2000, patent cases were roughly 33% of our docket. However, in recent years, our docket has changed. . . . Since 2013, when the impact of the AIA came to fruition, patent cases have . . . amounted to 63% in 2016.”). As you might imagine, a change of this magnitude has not been without controversy. It has even prompted constitutional challenges. This chapter starts with those challenges. Then, it gives a more detailed view of the different types of post-grant proceedings, including these newer proceedings as well as corrections and reissue.

### A. The PTAB and the Constitution

The USPTO has had some kind of adjudicatory body since the 1800s. Today, the USPTO’s primary adjudicatory body is the PTAB. It was created by the AIA to replace the agency’s former adjudicative body, the Board of Patent Appeals and Interferences (BPAI).

The PTAB presides over a number of pre- and post-issuance proceedings within the USPTO, “conduct[ing] trials, including inter partes, post-grant, and covered business method patent reviews and derivation proceedings, hear[ing] appeals from adverse examiner decisions in patent applications and reexamination proceedings, and render[ing] decisions in interferences.” *Patent Trial and Appeal Board*, U.S. PAT. & TRADEMARK OFF., <https://www.uspto.gov/patents/ptab> (last visited June 11, 2021). The Board’s membership includes both statutorily designated officials—the Director of the USPTO, the Deputy Director of the USPTO, the Commissioner for Patents, and the Commissioner for Trademarks—and administrative patent judges (APJs). Most proceedings before the PTAB are heard by panels of at least three members.

While the idea of USPTO adjudication is not new, the changes wrought by the AIA have prompted a host of questions regarding its constitutional underpinnings. Consider, for example, the following case, which involves “inter partes review,” or “IPR.” This administrative proceeding, created by the AIA, allows anyone to contest the validity of an issued patent, so long as the basis for invalidity satisfies certain statutory requirements.

*Oil States Energy Services, LLC v. Greene’s Energy Group, LLC*  
138 S. Ct. 1365 (2018)

Justice THOMAS delivered the opinion of the Court.

The Leahy–Smith America Invents Act, 35 U.S.C. § 100 et seq., establishes a process called “inter partes review.” Under that process, the United States Patent and Trademark Office (PTO) is authorized to reconsider and to cancel an issued patent claim in limited circumstances. In this case, we address whether inter partes review violates Article III or the Seventh Amendment of the Constitution. We hold that it violates neither.

...

B

Over the last several decades, Congress has created administrative processes that authorize the PTO to reconsider and cancel patent claims that were wrongly issued. . . .

[The Court began by describing an administrative proceeding that existed before the AIA and that somewhat resembled the AIA’s inter partes review at issue in this case.] In 1999, Congress added a procedure called “inter partes reexamination.” Under this procedure, any person could file a request for reexamination. The Director would determine if the request raised “a substantial new question of patentability affecting any claim of the patent” and, if so, commence a reexamination. The reexamination would follow the general procedures for initial examination, but would allow the third-party

## DESIGNS

requester and the patent owner to participate in a limited manner by filing responses and replies. Inter partes reexamination was phased out when the America Invents Act went into effect . . . .

### C

The America Invents Act replaced inter partes reexamination with inter partes review, the procedure at issue here. Any person other than the patent owner can file a petition for inter partes review. 35 U.S.C. § 311(a). The petition can request cancellation of “1 or more claims of a patent” on the grounds that the claim fails the novelty or nonobviousness standards for patentability. The challenges must be made “only on the basis of prior art consisting of patents or printed publications.” If a petition is filed, the patent owner has the right to file a preliminary response explaining why inter partes review should not be instituted.

[The Court then described the procedures associated with inter partes review.]

A party dissatisfied with the Board’s decision can seek judicial review in the Court of Appeals for the Federal Circuit. Any party to the inter partes review can be a party in the Federal Circuit. The Director can intervene to defend the Board’s decision, even if no party does. When reviewing the Board’s decision, the Federal Circuit assesses “the Board’s compliance with governing legal standards de novo and its underlying factual determinations for substantial evidence.”

### II

Petitioner Oil States Energy Services, LLC, and respondent Greene’s Energy Group, LLC, are both oilfield services companies. In 2001, Oil States obtained a patent relating to an apparatus and method for protecting wellhead equipment used in hydraulic fracturing. In 2012, Oil States sued Greene’s Energy in Federal District Court for infringing that patent. Greene’s Energy responded by challenging the patent’s validity. Near the close of discovery, Greene’s Energy also petitioned the Board to institute inter partes review. It argued that two of the patent’s claims were unpatentable because they were anticipated by prior art not mentioned by Oil States in its original patent application. Oil States filed a response opposing review. The Board found that Greene’s Energy had established a reasonable likelihood that the two claims were unpatentable and, thus, instituted inter partes review.

The proceedings before the District Court and the Board progressed in parallel. In June 2014, the District Court issued a claim-construction order. The order construed the challenged claims in a way that foreclosed Greene’s Energy’s arguments about the prior art. But a few months later, the Board issued a final written decision concluding that the

claims were unpatentable. The Board acknowledged the District Court's contrary decision, but nonetheless concluded that the claims were anticipated by the prior art.

Oil States sought review in the Federal Circuit. In addition to its arguments about patentability, Oil States challenged the constitutionality of inter partes review. Specifically, it argued that actions to revoke a patent must be tried in an Article III court before a jury. . . .

We granted certiorari to determine whether inter partes review violates Article III or the Seventh Amendment. We address each issue in turn.

### III

Article III vests the judicial power of the United States “in one supreme Court, and in such inferior Courts as the Congress may from time to time ordain and establish.” Consequently, Congress cannot “confer the Government's ‘judicial Power’ on entities outside Article III.” When determining whether a proceeding involves an exercise of Article III judicial power, this Court's precedents have distinguished between “public rights” and “private rights.” Those precedents have given Congress significant latitude to assign adjudication of public rights to entities other than Article III courts.

. . . Our precedents have recognized that the [public-rights] doctrine covers matters “which arise between the Government and persons subject to its authority in connection with the performance of the constitutional functions of the executive or legislative departments.” In other words, the public-rights doctrine applies to matters “‘arising between the government and others, which from their nature do not require judicial determination and yet are susceptible of it.’” Inter partes review involves one such matter: reconsideration of the Government's decision to grant a public franchise.

### A

Inter partes review falls squarely within the public-rights doctrine. This Court has recognized, and the parties do not dispute, that the decision to grant a patent is a matter involving public rights—specifically, the grant of a public franchise. Inter partes review is simply a reconsideration of that grant, and Congress has permissibly reserved the PTO's authority to conduct that reconsideration. Thus, the PTO can do so without violating Article III.

### 1

This Court has long recognized that the grant of a patent is a “‘matter involving public rights.’” It has the key features to fall within this Court's longstanding formulation of the public-rights doctrine.

## DESIGNS

*Ab initio*, the grant of a patent involves a matter “arising between the government and others.” As this Court has long recognized, the grant of a patent is a matter between “the public, who are the grantors, and . . . the patentee.” By “issuing patents,” the PTO “takes from the public rights of immense value, and bestows them upon the patentee.” Specifically, patents are “public franchises” that the Government grants “to the inventors of new and useful improvements.” The franchise gives the patent owner “the right to exclude others from making, using, offering for sale, or selling the invention throughout the United States.” 35 U.S.C. § 154(a)(1). That right “did not exist at common law.” Rather, it is a “creature of statute law.”

Additionally, granting patents is one of “the constitutional functions” that can be carried out by “the executive or legislative departments” without “judicial determination.” Article I gives Congress the power “to promote the Progress of Science and useful Arts, by securing for limited Times to Authors and Inventors the exclusive Right to their respective Writings and Discoveries.” § 8, cl. 8. Congress can grant patents itself by statute. And, from the founding to today, Congress has authorized the Executive Branch to grant patents that meet the statutory requirements for patentability. See 35 U.S.C. §§ 2(a)(1), 151. When the PTO “adjudicates the patentability of inventions,” it is “exercising the executive power.”

Accordingly, the determination to grant a patent is a “matter involving public rights.” It need not be adjudicated in Article III court.

## 2

Inter partes review involves the same basic matter as the grant of a patent. So it, too, falls on the public-rights side of the line.

Inter partes review is “a second look at an earlier administrative grant of a patent.” *Cuozzo Speed Technologies, LLC v. Lee*, 136 S. Ct. 2131, 2144 (2016). The Board considers the same statutory requirements that the PTO considered when granting the patent. See 35 U.S.C. § 311(b). Those statutory requirements prevent the “issuance of patents whose effects are to remove existent knowledge from the public domain.” *Graham v. John Deere Co. of Kansas City*, 383 U.S. 1, 6 (1966). So, like the PTO’s initial review, the Board’s inter partes review protects “the public’s paramount interest in seeing that patent monopolies are kept within their legitimate scope,” *Cuozzo*, 136 S. Ct. at 2144. Thus, inter partes review involves the same interests as the determination to grant a patent in the first instance.

The primary distinction between inter partes review and the initial grant of a patent is that inter partes review occurs *after* the patent has issued. But that distinction does not make a difference here. Patent claims are granted subject to the qualification that the PTO has “the authority to reexamine—and perhaps cancel—a patent claim” in an inter partes

review. *See Cuozzo*, 136 S. Ct. at 2137. Patents thus remain “subject to the Board’s authority” to cancel outside of an Article III court.

This Court has recognized that franchises can be qualified in this manner. For example, Congress can grant a franchise that permits a company to erect a toll bridge, but qualify the grant by reserving its authority to revoke or amend the franchise. Even after the bridge is built, the Government can exercise its reserved authority through legislation or an administrative proceeding. The same is true for franchises that permit companies to build railroads or telegraph lines.

Thus, the public-rights doctrine covers the matter resolved in inter partes review. The Constitution does not prohibit the Board from resolving it outside of an Article III court.

## B

Oil States challenges this conclusion, citing three decisions that recognize patent rights as the “private property of the patentee.” *United States v. American Bell Telephone Co.*, 128 U.S. 315, 370 (1888); *see also McCormick Harvesting Machine Co. v. Aultman*, 169 U.S. 606, 609 (1898) (“A granted patent has become the property of the patentee”); *Brown v. Duchesne*, 19 How. 183, 197 (1857) (“The rights of a party under a patent are his private property”). But those cases do not contradict our conclusion.

Patents convey only a specific form of property right—a public franchise. And patents are “entitled to protection as any other property, *consisting of a franchise.*” As a public franchise, a patent can confer only the rights that “the statute prescribes.” It is noteworthy that one of the precedents cited by Oil States acknowledges that the patentee’s rights are “derived altogether” from statutes, “are to be regulated and measured by these laws, and cannot go beyond them.” *Brown*, 19 How. at 195.

One such regulation is inter partes review. *See Cuozzo*, 136 S. Ct. at 2137. The Patent Act provides that, “subject to the provisions of this title, patents shall have the attributes of personal property.” 35 U.S.C. § 261. This provision qualifies any property rights that a patent owner has in an issued patent, subjecting them to the express provisions of the Patent Act. *See eBay Inc. v. MercExchange, L.L.C.*, 547 U.S. 388, 392 (2006). Those provisions include inter partes review. *See* §§ 311–319.

Nor do the precedents that Oil States cites foreclose the kind of post-issuance administrative review that Congress has authorized here. To be sure, two of the cases make broad declarations that “the only authority competent to set a patent aside, or to annul it, or to correct it for any reason whatever, is vested in the courts of the United States, and not in the department which issued the patent.” But those cases were decided under the Patent Act of 1870. That version of the Patent Act did not include any provision for post-issuance administrative review. Those precedents, then, are best read as a



## DESIGNS

description of the statutory scheme that existed at that time. They do not resolve Congress' authority under the Constitution to establish a different scheme.

...

### E

We emphasize the narrowness of our holding. We address the constitutionality of inter partes review only. We do not address whether other patent matters, such as infringement actions, can be heard in a non-Article III forum. And because the Patent Act provides for judicial review by the Federal Circuit, see 35 U.S.C. § 319, we need not consider whether inter partes review would be constitutional "without any sort of intervention by a court at any stage of the proceedings." Moreover, we address only the precise constitutional challenges that Oil States raised here. Oil States does not challenge the retroactive application of inter partes review, even though that procedure was not in place when its patent issued. Nor has Oil States raised a due process challenge. Finally, our decision should not be misconstrued as suggesting that patents are not property for purposes of the Due Process Clause or the Takings Clause.

### IV

In addition to Article III, Oil States challenges inter partes review under the Seventh Amendment. The Seventh Amendment preserves the "right of trial by jury" in "Suits at common law, where the value in controversy shall exceed twenty dollars." This Court's precedents establish that, when Congress properly assigns a matter to adjudication in a non-Article III tribunal, "the Seventh Amendment poses no independent bar to the adjudication of that action by a nonjury factfinder." No party challenges or attempts to distinguish those precedents. Thus, our rejection of Oil States' Article III challenge also resolves its Seventh Amendment challenge. Because inter partes review is a matter that Congress can properly assign to the PTO, a jury is not necessary in these proceedings.

### V

Because inter partes review does not violate Article III or the Seventh Amendment, we affirm the judgment of the Court of Appeals. It is so ordered.

Justice BREYER, with whom Justice GINSBURG and Justice SOTOMAYOR join, concurring.

I join the Court's opinion in full. The conclusion that inter partes review is a matter involving public rights is sufficient to show that it violates neither Article III nor the Seventh Amendment. But the Court's opinion should not be read to say that matters involving private rights may never be adjudicated other than by Article III courts, say, sometimes by agencies. Our precedent is to the contrary.

Justice GORSUCH, with whom THE CHIEF JUSTICE joins, dissenting.

Today, the government invites us to retreat from the promise of judicial independence. Until recently, most everyone considered an issued patent a personal right—no less than a home or farm—that the federal government could revoke only with the concurrence of independent judges. But in the statute before us Congress has tapped an executive agency, the Patent Trial and Appeal Board, for the job. Supporters say this is a good thing because the Patent Office issues too many low quality patents; allowing a subdivision of that office to clean up problems after the fact, they assure us, promises an efficient solution. And, no doubt, dispensing with constitutionally prescribed procedures is often expedient. . . .

. . .

. . . At the founding, the Court notes, the Executive could sometimes both dispense and revoke public franchises. And because, it says, invention patents are a species of public franchises, the Court argues the Executive should be allowed to dispense and revoke them too. But labels aside, by the time of the founding the law treated patents protected by the Patent Clause quite differently from ordinary public franchises. . . . Courts routinely applied to invention patents protected by the Patent Clause the “liberal common sense construction” that applies to other instruments creating private property rights, like land deeds. As Justice Story explained, invention patents protected by the Patent Clause were “not to be treated as mere monopolies odious in the eyes of the law, and therefore not to be favored.” . . . For precisely these reasons and as we’ve seen, the law traditionally treated patents issued under the Patent Clause very differently than monopoly franchises when it came to governmental invasions. Patents alone required independent judges. Nor can simply invoking a mismatched label obscure that fact. The people’s historic rights to have independent judges decide their disputes with the government should not be a “constitutional Maginot Line, easily circumvented” by such “simple maneuvers.”

Today’s decision may not represent a rout but it at least signals a retreat from Article III’s guarantees. Ceding to the political branches ground they wish to take in the name of efficient government may seem like an act of judicial restraint. But enforcing Article III isn’t about protecting judicial authority for its own sake. It’s about ensuring the people today and tomorrow enjoy no fewer rights against governmental intrusion than those who came before. And the loss of the right to an independent judge is never a small thing. It’s for that reason Hamilton warned the judiciary to take “all possible care to defend itself against” intrusions by the other branches. The Federalist No. 78, at 466. It’s for that reason I respectfully dissent.

## Context &amp; Application

1. In light of *Oil States*, it is pretty clear that patents owned by private entities can be constitutionally challenged by other private parties in IPRs. But what about patents owned by state institutions? States “typically enjoy immunity from lawsuits brought by private parties as a ‘fundamental aspect of the sovereignty which the States enjoyed before the ratification of the Constitution, and which they retain today.’” *Regents of the Univ. of Minn. v. LSI Corp.*, 926 F.3d 1327, 1337 (2019). This “state sovereign immunity” is to a certain extent preserved by the Eleventh Amendment to the U.S. Constitution and “applies not only to proceedings in an Article III forum but also to agency adjudications brought by private parties that are similar to court adjudications.” As a result, the University of Minnesota argued that, because IPRs challenging state-owned patents “are entirely disputes between private parties and states” and are run much like court proceedings, they should be barred by state sovereign immunity.

The Federal Circuit rejected this argument. Following the Supreme Court’s logic in *Cuozzo Speed Technologies, LLC v. Lee*, 136 S. Ct. 2131 (2016), it “concluded that IPR proceedings are essentially agency reconsideration of a prior patent grant.” *Regents of the Univ. of Minn.*, 926 F.3d at 1338. Thus, while this “second look” is initiated upon the petition of a private party and resembles civil litigation, such party involvement and the adversarial nature of the proceedings do not undermine their fundamental character as agency-initiated actions. *Id.* Supporting this, the court noted, was the fact that both ex parte reexamination and inter partes reexamination—which may be or were, respectively, initiated by third parties—were beyond the reach of state sovereign immunity.

The Federal Circuit gave several reasons for its holding. It first noted that the Director of the USPTO, a “politically appointed executive branch official ultimately decides whether to proceed against the state sovereign” upon review of an appropriate petition, and that this decision is committed to the Director’s discretion. Next, it pointed out that the PTAB may issue a final written decision on the merits of an IPR, even if no petitioner remains a party to the proceeding, “reinforcing the view that IPR is an act by the agency in reconsidering its own grant of a public franchise.” Further informing its decision was the fact that there were several procedural differences between civil litigation and IPRs, such as the inapplicability of the Federal Rules of Civil Procedure to the latter. As a result, the court concluded that “IPR is similar to an agency enforcement action instituted by the USPTO upon information supplied by a private party rather than civil litigation, so state sovereign immunity is not implicated.” The Federal Circuit similarly rebuffed arguments made in favor of tribal sovereign immunity barring IPR proceedings initiated against patents owned by Native American Tribes. See *Saint Regis Mohawk Tribe v. Mylan Pharm., Inc.*, 896 F.3d 1322 (Fed. Cir. 2018), *cert. denied*, 139 S. Ct. 1547 (2019).

2. We have now discussed several questions relating to the scope of the PTAB's adjudicatory authority, but other fundamental questions remain about the structure and composition of the PTAB. As noted earlier, the PTAB is comprised of a select few statutorily designated officials and a number of APJs; these APJs, according to the Patent Act, are appointed by the Secretary of Commerce "in consultation with the Director" of the USPTO. 35 U.S.C. § 6(a). The Federal Circuit has held that this appointment structure violates the Appointments Clause of Article II of the U.S. Constitution, *Arthrex, Inc. v. Smith & Nephew, Inc.*, 941 F.3d 1320, 1325 (2019), which requires certain "principal officers" wielding significant governmental authority to be nominated by the President with the advice and consent of the Senate, *see Buckley v. Valeo*, 424 U.S. 1, 125–26, 133 (1976). The Federal Circuit concluded that APJs constituted principal officers who were unconstitutionally appointed, but that severance of "certain statutory limitations on the removal of APJs"—in particular, those limitations that permitted their removal only for cause under 5 U.S.C. § 7513(a)—would ultimately eliminate this constitutional defect. *Arthrex*, 941 F.3d at 1338. The Supreme Court granted certiorari to a consolidated petition to resolve these issues in *United States v. Arthrex Inc.*, No. 19-1434; oral argument was heard on March 1, 2021. The Supreme Court's decision was still pending as of this writing.

## B. Post-Issuance Administrative Review Processes

Post-grant proceedings are effectively a recognition that the USPTO is not infallible. Sometimes issued patents contain errors, or a claimed invention that does not meet the requirements for patentability receives a patent. There are processes for fixing these errors. Some of these proceedings, such as *ex parte* reexamination, have been around for decades. Others, such as *inter partes* review and post-grant review, are less than a decade old. Still others, such as *inter partes* reexamination and covered business method patent review, have been introduced and then cancelled or phased out.

We will address the basics of many of these proceeding below. As you read, keep in mind that the outcomes can significantly affect not only the validity of an issued patent but also the scope of later litigation. Lawyers can—and have—built entire practices upon these types of administrative proceedings.

### 1. Post-Grant Review

PGR is the most temporally limited post-grant proceeding in nature. The proceeding was added by the AIA and can only be invoked in the first nine months following issuance, and only for patents issued from first-to-file applications filed on or after March 16, 2013. 35 U.S.C. § 321 *et seq.*

## DESIGNS

The Patent Act authorizes “a person who is not the owner of a patent [to] file with the Office a petition to institute a post-grant review of [a] patent,” 35 U.S.C. § 321(a), through which the “petitioner . . . may request to cancel as unpatentable [one] or more claims of a patent on any ground that could be raised under paragraph (2) or (3) of section 282(b),” 35 U.S.C. § 321(b).

In other words, PGR permits a third party (i.e., not the patent owner) to file a petition with the Director of the USPTO to challenge the validity of and cancel one or more claims of a patent upon any ground that they could in a district court (including issues of patent eligibility, utility, novelty, obviousness, written description, and enablement but *excluding* compliance with the best mode requirement). PGR challenges can be supported with a wide variety of evidence, including printed publications, issued patents, evidence of on-sale activities or public use, and prior-filed patent applications, among others. The challenges are generally handled by the PTAB (rather than the original patent examiner who handled the patent’s prosecution). The proceedings are similar litigation in district court, in that the parties can conduct discovery, deliver oral arguments, and arrange settlements, though these endeavors are subject to some limitations. Overall, PGR provides a third party significant opportunity to challenge the validity of a granted patent immediately after issuance in a litigation-like format.

The timing requirements limit the use and popularity of PGR proceedings. A petition to institute PGR must be filed by a third party within nine (9) months of patent issuance, though PGR challenges can also be brought within nine months of issuance of a reissue patent, subject to a single caveat: any challenge to one or more claims in a reissue patent that are similar to or narrower than claims in the originally issued patent cannot be made unless brought within nine months of the original patent’s date of issuance.

The entire proceeding is conducted according to a condensed timeline: Once a petitioner files their request, the patentee is generally given two months to respond, after which the Director of the USPTO has three months to decide whether to institute the proceeding. If the Director chooses to institute PGR and that proceeding is not later dismissed for one reason or another, the PTAB has one year from institution to issue a final determination—a deadline that may be extended for good cause by an additional six months. After a final determination is rendered, appeals by the petitioner or patent owner, under 35 U.S.C. § 329, may be taken to the Federal Circuit.

When are PGR proceedings generally instituted? The standard for institution is set by 35 U.S.C. § 324, which states that the Director of the USPTO may institute PGR proceedings if either “the information presented in the petition filed under section 321, if such information is not rebutted, would demonstrate that it is more likely than not that at least [one] of the claims challenged in the petition is unpatentable,” 35 U.S.C. § 324(a), or “the petition raises a novel or unsettled legal question that is important to other patents

or patent applications,” 35 U.S.C. § 324(b). In other words, the Director can choose to institute PGR if they think that the petitioner would more likely than not succeed on the merits of their challenge to at least one claim of the patent based on the unrebutted contents of the petition, or, alternatively, that the petitioner has brought forth important questions of patent law that should be addressed because they are likely to affect a wide range of stakeholders in the patent system. The Director’s decision in this regard “shall be final and nonappealable.” 35 U.S.C. § 324(e). This is the same standard for institution of IPR, challenged in *Cuozzo Speed Technologies, LLC v. Lee*, 136 S. Ct. 2131 (2016), below.

There are other limitations on PGR proceedings beyond the time constraints described above. For example, a would-be petitioner (or a real party in interest) cannot request institution of a PGR proceeding if they earlier filed a civil action (declaratory or otherwise) challenging the validity of the patent. Importantly, this limitation does not apply to defendants’ counterclaims of invalidity in patent infringement actions. In a similar vein, any civil action filed by a PGR petitioner after institution of PGR proceedings will ordinarily be stayed until those proceedings conclude; such a civil action will not be stayed if one of the following occurs: “the patent owner moves the court to lift the stay; . . . the patent owner files a civil action or counterclaim alleging that the petitioner or real party in interest has infringed the patent; or . . . the petitioner or real party in interest moves the court to dismiss the action.” 35 U.S.C. § 325(a)(2). The idea here is to promote efficiency and uniformity; avoiding parallel proceedings serves those goals.

And finally, PGR carries with it one major risk. Section 325(e) explains that an issue may not be raised in *any other proceeding* before the USPTO, in federal court, or in the ITC if the PTAB rendered a final written decision and that issue was “raised or reasonably could have [been] raised” by the petitioner “during that post-grant review.” 35 U.S.C. § 325(e)(1), (2). In other words, this provision broadly estops a PGR petitioner or a related real party in interest from bringing up claims that were or reasonably could have been brought during the PGR proceedings, whether they choose to do so in later USPTO administrative proceedings or in certain proceedings in federal court or before the ITC, if the PTAB issued a final written decision upon the merits of the PGR. As a result, a potential petitioner is strongly advised to consider the costs and benefits of submitting a PGR petition. While PGR is significantly less time-consuming than district court litigation and certainly much less expensive, it does come with the risk of estoppel.

## 2. Inter Partes Review

Inter partes review (IPR) is perhaps the most actively used administrative procedure in patent law today. Much of the case law covered in this chapter derives from IPR challenges to patent validity. This is quite astounding in view of its relatively short

history: originating with the AIA and outlined in 35 U.S.C. § 311 *et seq.*, it was designed to replace an older procedure, inter partes reexamination, as late as September 16, 2012. However, unlike PGR, it can be used to challenge any issued patent, no matter its filing date. Justice Thomas, in his majority opinion in *Oil States Energy Services v. Greene's Energy Group, LLC*, 138 S. Ct. 1365 (2018), provides an overview of the history and substance of IPR:

The America Invents Act replaced inter partes reexamination with inter partes review. . . . Any person other than the patent owner can file a petition for inter partes review. 35 U.S.C. § 311(a). The petition can request cancellation of “1 or more claims of a patent” on the grounds that the claim fails the novelty or nonobviousness standards for patentability. § 311(b). The challenges must be made “only on the basis of prior art consisting of patents or printed publications.” *Ibid.* If a petition is filed, the patent owner has the right to file a preliminary response explaining why inter partes review should not be instituted. § 313.

Before he can institute inter partes review, the Director must determine “that there is a reasonable likelihood that the petitioner would prevail with respect to at least 1 of the claims challenged.” § 314(a). The decision whether to institute inter partes review is committed to the Director's discretion. *See Cuozzo Speed Technologies, LLC v. Lee*, 136 S. Ct. 2131, 2140 (2016). The Director's decision is “final and nonappealable.” § 314(d).

Once inter partes review is instituted, the Patent Trial and Appeal Board—an adjudicatory body within the PTO created to conduct inter partes review—examines the patent's validity. *See* 35 U.S.C. §§ 6, 316(c). The Board sits in three-member panels of administrative patent judges. *See* § 6(c). During the inter partes review, the petitioner and the patent owner are entitled to certain discovery, § 316(a)(5); to file affidavits, declarations, and written memoranda, § 316(a)(8); and to receive an oral hearing before the Board, § 316(a)(10). The petitioner has the burden of proving unpatentability by a preponderance of the evidence. § 316(e). The owner can file a motion to amend the patent by voluntarily canceling a claim or by “proposing a reasonable number of substitute claims.” § 316(d)(1)(B). The owner can also settle with the petitioner by filing a written agreement prior to the Board's final decision, which terminates the proceedings with respect to that petitioner. § 317. If the settlement results in no petitioner remaining in the inter partes review, the Board can terminate the proceeding or issue a final written decision. § 317(a).

If the proceeding does not terminate, the Board must issue a final written decision no later than a year after it notices the institution of inter partes review, but that deadline can be extended up to six months for good cause. §§ 316(a)(11), 318(a). If

the Board's decision becomes final, the Director must "issue and publish a certificate." § 318(b). The certificate cancels patent claims "finally determined to be unpatentable," confirms patent claims "determined to be patentable," and incorporates into the patent "any new or amended claim determined to be patentable." *Ibid.*

As Justice Thomas explains, a third party (i.e., not the patent owner) may file a petition to institute IPR proceedings on the basis of a challenge to the patent's novelty or nonobviousness, as evidenced *only* by issued patents or printed publications. This means that IPR proceedings are substantially more limited in substantive scope than PGR.

Note, too, that although the Director of the USPTO must decide whether to institute IPR proceedings within three months of the receipt of a patent owner's preliminary response to the petition, institution of IPR proceedings is subject to a different standard. Instead of the PGR standard (which requires a determination of whether it is more likely than not that a petitioner would succeed on the merits of the claim or that there is involved in the dispute an important question of patent law), to institute an IPR, the Director must find that the petitioner is reasonably likely to prevail on the merits with respect to at least one of the challenged claims. This is a higher standard than the one set for PGR.

Like PGR, however, IPR is also restricted temporally: an IPR petition cannot be filed until either after nine months from patent issuance, or, if PGR proceedings have already been instituted against the patent in question, the date those proceedings conclude. In other words, the USPTO uses temporal windows of opportunity to funnel would-be challengers into selecting either PGR or IPR to pursue their challenges. A potential IPR petitioner can file a petition to initiate IPR anytime after the IPR window opens except in one situation established under 35 U.S.C. § 315(b): where a petitioner or a related real party in interest has been served with a complaint alleging infringement of the patent sought to be challenged, the petitioner must file to institute IPR proceedings within one year; otherwise, her remedy is to challenge the validity of the patent in court in connection with the litigated dispute.

Further, as with PGR, civil actions (not including counterclaims asserted by defendants in patent infringement cases) initiated after an IPR has been instituted will be automatically stayed under 35 U.S.C. § 315(a)(2), though proceedings brought before such institution will not. And finally, IPR proceedings are subject to an estoppel provision, 35 U.S.C. § 315(e), that closely resembles the PGR estoppel section: it provides that, if the PTAB issues a final written decision upon the merits of the IPR, the IPR petitioner or a related real party in interest is estopped from asserting claims that were or reasonably could have been raised during the IPR proceedings in later USPTO administrative proceedings or in certain proceedings in federal court or before the ITC.



### 3. Covered Business Method Patent Review

A third type of trial-like administrative proceeding conducted before the PTAB falls under the purview of the Transitional Program for Covered Business Methods (TPCBM), which was established on September 16, 2012, to streamline the review of validity challenges against a specific category of patents called “covered business method patents.” Covered business method (CBM) patents include those patents for methods or apparatuses pertaining to data processing within, or the operation, management, or administration of, a financial product or service that lack significant technological elements. In order to supplement this somewhat nebulous definition, the USPTO has issued guidance on what constitutes a qualifying CBM patent and a non-qualifying “technological invention” in *Transitional Program for Covered Business Method Patents—Definitions of Covered Business Method Patent and Technological Invention*, 77 Fed. Reg. 48,734 (Aug. 14, 2012). These TPCBM proceedings are conducted in much the same way that PGR proceedings are conducted, save a few, very particular exceptions: TPCBM proceedings may only be instituted against CBM patents that have not been the subject of PGR proceedings, and *only* when the petitioner or a related real party in interest has been either (1) sued for infringement of the patent sought to be challenged, or (2) “charged with infringement” of said patent in a manner sufficient to give rise to a “real and substantial controversy” upon which “the petitioner would have standing to bring a declaratory judgment action in Federal court.” 37 C.F.R. § 42.302(a). After an eight-year lifespan, the TPCBM is currently phasing out almost as quickly as it came into being. Though the regulations pertaining to the program will continue to apply to those proceedings already in being before September 16, 2020, the USPTO will no longer consider petitions to institute TPCBM proceedings filed on or after that date. As a result, while you may encounter one or two of these cases in your future practice, they are fast becoming obsolete.

### 4. Ex Parte Reexamination

*Quantum Corp. v. Rodime, PLC*  
65 F.3d 1577 (Fed. Cir. 1995)

PLAGER, Circuit Judge.

The question in this declaratory judgment action is whether amendments made during a prior reexamination proceeding impermissibly broadened the scope of the patent claims at issue in violation of 35 U.S.C. § 305 (1988), and, if so, the legal effect thereof. Defendant patentee Rodime PLC (Rodime) appeals . . . . In its decision, the district court

granted Quantum Corporation's (Quantum) motion for summary judgment that Claims 4, 6, 7, 9, 14 and 19–27 of U.S. Patent No. 4,638,383 (the reexamined '383 patent) are invalid because they were impermissibly broadened during reexamination. We affirm.

I

A

Rodime is the owner of the reexamined '383 patent . . . . The reexamined '383 patent is directed to a micro hard-disk drive system (3.5 inch drive) suitable for use in portable computers . . . .

The claim limitation at issue in this appeal relates to the storage capability of the hard-disk. The storage capability of a hard-disk is a function of the track density; the greater the track density, the more data that can be stored in a given area of the disk. Track density may be defined in terms of "tracks per inch" (tpi), calculated based on the number of concentric tracks present within an inch along the radius of the hard-disk.

On November 19, 1985, James G. McGinley and Roderick M. Urquhart, two engineers at Rodime, filed a patent application for the invention described above. Claim 1 of this application recited, *inter alia*, a track density of "approximately 600" tpi. The examiner, in a first office action, rejected all the claims as obvious under 35 U.S.C. § 103. . . .

. . .

In a response dated May 23, 1986, applicants cancelled the original claims and inserted new claims some of which recited a track density of "at least 600" tpi. The examiner subsequently allowed these new claims, and the patent issued on January 20, 1987, as U.S. Patent No. 4,638,383 (the original '383 patent). Claims 4, 6, 7, 9, and 14 of the original '383 patent all recited a track density of "at least 600 concentric tracks per inch."

On September 28, 1987, Rodime, the owner of the original '383 patent pursuant to an assignment from the inventors, requested reexamination of its patent. Finding a substantial new question of patentability, see 35 U.S.C. § 303, the United States Patent and Trademark Office (PTO) granted Rodime's request for reexamination of all 16 claims in the original '383 patent. In an office action dated April 19, 1988, the examiner rejected all but two of the original claims. Rodime responded by cancelling certain claims, amending others, and adding dependent Claims 17–31. With respect to the claims at issue in this appeal, Rodime made substantial amendments including changing the track density limitation from "at least 600" tpi to "at least approximately 600" tpi. These claims were allowed, as amended, and the '383 reexamined patent issued on November 29, 1988, as U.S. Patent No. B1 4,638,383. As issued, independent Claims 4, 6, 7, 9, and 14 of the reexamined '383 patent all recite a track density of "at least approximately 600" tpi, and

## DESIGNS

the newly added dependent claims which are at issue in this appeal, i.e. Claims 19–27, either explicitly contain this limitation or incorporate it through their dependency.

...

### II

There are two issues in this case: first, whether Rodime broadened the scope of the claims at issue during reexamination in violation of 35 U.S.C. § 305 by changing the track density limitation from “at least 600 tpi” to “at least approximately 600 tpi,” and, second, assuming the claims were impermissibly broadened, the legal effect of violating section 305. . . .

#### A

35 U.S.C. § 305 states, in relevant part, that “no proposed amended or new claim enlarging the scope of a claim of the patent will be permitted in a reexamination proceeding.” An amended or new claim has been enlarged if it includes within its scope any subject matter that would not have infringed the original patent. “A claim that is broader in any respect is considered to be broader than the original claims even though it may be narrower in other respects.” . . .

...

Since the amended limitation includes subject matter not covered by the original claims, i.e. track densities below 600 tpi, we conclude that Rodime expanded the scope of their claims during reexamination in violation of 35 U.S.C. § 305. . . .

...

#### B

But what are the consequences of such a broadening? Are the claims entirely invalid, or is invalidity limited only to the broadened aspects of the claims, so that the original scope of the claims remains available to the patentee? The district court’s analysis concluded when it determined that the reexamined claims were broader than the original claims in the ’383 patent, apparently believing that it necessarily followed that the claims at issue are therefore invalid. However, the Patent Act is silent regarding the proper remedy to be employed by a district court in a patent infringement suit when it determines that claims were improperly broadened during reexamination in violation of 35 U.S.C. § 305. Neither the express words in section 305 nor its legislative history provide any guidance in this situation; they merely recite the prohibition against broadening during reexamination.

...

Our precedent does not address this issue either. . . .

Despite the absence of specific statutory language or precedent of this court in support of the district court's judgment that the claims at issue are invalid, we conclude that, as a matter of law, the district court arrived at the correct result. The purpose of the reexamination process is to provide a mechanism for reaffirming or correcting the PTO's action in issuing a patent by reexamining patents thought to be of doubtful validity. Consistent with this overall purpose, Congress enacted section 305 which, while allowing an applicant to amend his claims or add new claims to distinguish his invention over cited prior art, explicitly prohibits any broadening of claims during reexamination. If an applicant fails to claim as broadly as he or she could have, the proper recourse, if within two years of issuance of the patent, is to file a reissue application, *see* 35 U.S.C. § 251, not to remedy this problem in a reexamination proceeding.

As with violations of other statutes in the Patent Act, claims that do not comply with section 305 cannot stand. Rodime agrees, but maintains that the proper recourse is for this court to exercise its inherent equitable powers by restricting the scope of the claims to their original terms, avoiding a holding of infringement against any devices that would not have been covered by any of the original claims as they existed prior to reexamination. We disagree. Although we construe claims, if possible, so as to sustain their validity, it is well settled that no matter how great the temptations of fairness or policy making, courts do not redraft claims. Moreover, even if we could consider equities, they do not favor Rodime; they broadened their claims during reexamination despite the explicit prohibition against doing so in section 305.

Likewise, the district court cannot remand the case to the PTO to have the broadening language deleted from the claims. To conclude otherwise would discourage instead of encourage compliance with section 305. If the only penalty for violating section 305 is a remand to the PTO to have the reexamined claims narrowed to be commensurate in scope with what the applicant was only entitled to in the first place, then applicants will have an incentive to attempt to broaden their claims during reexamination, and, if successful, be able to enforce these broadened claims against their competitors. This result essentially renders the prohibition in section 305 meaningless. The likelihood that improperly broadened claims will be held invalid will discourage applicants from attempting to broaden their claims during reexamination.

...

Affirmed.

### C. Institution of Post-Issuance Administrative Proceedings

One area of post-grant proceedings that has been subject to a fair amount of litigation is the process for instituting review. The two cases below address the level of discretion granted to the Director—in *Cuozzo v. Lee*, to institute IPR, and in *SAS Institute Inc. v. Iancu*, to determine which claims merit review.

*Cuozzo Speed Technologies, LLC v. Lee*  
136 S. Ct. 2131 (2016)

Justice BREYER delivered the opinion of the Court.

The Leahy–Smith America Invents Act, 35 U.S.C. § 100 *et seq.*, creates a process called “inter partes review.” That review process allows a third party to ask the U.S. Patent and Trademark Office to reexamine the claims in an already-issued patent and to cancel any claim that the agency finds to be unpatentable in light of prior art. See § 102 (requiring “novelty”); § 103 (disqualifying claims that are “obvious”).

We consider two provisions of the Act. [Editors’ note: the Court’s discussion of the second provision can be found in Chapter 8.] The first says:

“No Appeal.—The determination by the Director [of the Patent Office] whether to institute an inter partes review under this section shall be final and non-appealable.” § 314(d).

Does this provision bar a court from considering whether the Patent Office wrongly “determined to institute an inter partes review,” when it did so on grounds not specifically mentioned in a third party’s review request?

...

We conclude that the first provision, though it may not bar consideration of a constitutional question, for example, does bar judicial review of the kind of mine-run claim at issue here, involving the Patent Office’s decision to institute inter partes review.

I

A

In 2011, Congress enacted the statute before us. That statute modifies “inter partes reexamination,” which it now calls “inter partes review.” Like inter partes reexamination, any third party can ask the agency to initiate inter partes review of a patent claim. But the new statute has changed the standard that governs the Patent Office’s institution of the agency’s process. Instead of requiring that a request for reexamination raise a “substantial

## CHAPTER 12

new question of patentability,” it now requires that a petition show “a reasonable likelihood that” the challenger “would prevail.” And, the statute says that the agency’s initial decision “whether to institute an inter partes review” is “final and nonappealable.” § 314(d).

### B

In 2002, Giuseppe A. Cuozzo applied for a patent covering a speedometer that will show a driver when he is driving above the speed limit. . . .

In 2004, the Patent Office granted the patent. *See* U.S. Patent No. 6,778,074 (Cuozzo Patent). . . .

### C

Petitioner Cuozzo Speed Technologies, LLC (Cuozzo), now holds the rights to the Cuozzo Patent. In 2012, Garmin International, Inc., and Garmin USA, Inc., filed a petition seeking inter partes review of the Cuozzo Patent’s 20 claims. . . .

The Board agreed to reexamine claim 17, as well as claims 10 and 14. The Board recognized that Garmin had not expressly challenged claim 10 and claim 14 on the same obviousness ground. But, believing that “claim 17 depends on claim 14 which depends on claim 10,” the Board reasoned that Garmin had “implicitly” challenged claims 10 and 14 on the basis of the same prior inventions, and it consequently decided to review all three claims together.

After proceedings before the Board, it concluded that claims 10, 14, and 17 of the Cuozzo Patent were obvious in light of the earlier patents to which Garmin had referred . . . . [and] ordered claims 10, 14, and 17 of the Cuozzo Patent canceled.

Cuozzo appealed to the United States Court of Appeals for the Federal Circuit. Cuozzo argued that the Patent Office improperly instituted inter partes review, at least in respect to claims 10 and 14, because the agency found that Garmin had only *implicitly* challenged those two claims . . . while the statute required petitions to set forth the grounds for challenge “with particularity.” § 312(a)(3). [The Court of Appeals rejected the argument and certiorari was granted.]

### II

Like the Court of Appeals, we believe that Cuozzo’s contention that the Patent Office unlawfully initiated its agency review is not appealable. For one thing, that is what § 314(d) says. It states that the “determination by the Patent Office whether to institute an inter partes review under this section shall be *final and nonappealable.*”

For another, the legal dispute at issue is an ordinary dispute about the application of certain relevant patent statutes concerning the Patent Office’s decision to institute inter

partes review. Cuozzo points to a related statutory section, § 312, which says that petitions must be pleaded “with particularity.” Those words, in its view, mean that the petition should have specifically said that claims 10 and 14 are also obvious in light of this same prior art. Garmin’s petition, the Government replies, need not have mentioned claims 10 and 14 separately, for claims 10, 14, and 17 are all logically linked; the claims “rise and fall together,” and a petition need not simply repeat the same argument expressly when it is so obviously implied. In our view, the “No Appeal” provision’s language must, at the least, forbid an appeal that attacks a “determination . . . whether to institute” review by raising this kind of legal question and little more.

Moreover, a contrary holding would undercut one important congressional objective, namely, giving the Patent Office significant power to revisit and revise earlier patent grants. We doubt that Congress would have granted the Patent Office this authority, including, for example, the ability to continue proceedings even after the original petitioner settles and drops out, § 317(a), if it had thought that the agency’s final decision could be unwound under some minor statutory technicality related to its preliminary decision to institute inter partes review.

Further, the existence of similar provisions in this, and related, patent statutes reinforces our conclusion. *See* § 319 (limiting appellate review to the “final written decision”).

...

We recognize the “strong presumption” in favor of judicial review that we apply when we interpret statutes, including statutes that may limit or preclude review. This presumption, however, may be overcome by “clear and convincing” indications, drawn from “specific language,” “specific legislative history,” and “inferences of intent drawn from the statutory scheme as a whole,” that Congress intended to bar review. That standard is met here. Congress has told the Patent Office to determine whether inter partes review should proceed, and it has made the agency’s decision “final” and “nonappealable.” Our conclusion that courts may not revisit this initial determination gives effect to this statutory command. . . .

Nevertheless, in light of § 314(d)’s own text and the presumption favoring review, we emphasize that our interpretation applies where the grounds for attacking the decision to institute inter partes review consist of questions that are closely tied to the application and interpretation of statutes related to the Patent Office’s decision to initiate inter partes review. *See* § 314(d) (barring appeals of “determinations to initiate an inter partes review *under this section.*” This means that we need not, and do not, decide the precise effect of § 314(d) on appeals that implicate constitutional questions, that depend on other less closely related statutes, or that present other questions of interpretation that reach, in

terms of scope and impact, well beyond “this section.” Thus, contrary to the dissent’s suggestion, we do not categorically preclude review of a final decision where a petition fails to give “sufficient notice” such that there is a due process problem with the entire proceeding, nor does our interpretation enable the agency to act outside its statutory limits by, for example, canceling a patent claim for “indefiniteness under § 112” in inter partes review. Such “shenanigans” may be properly reviewable in the context of § 319 and under the Administrative Procedure Act, which enables reviewing courts to “set aside agency action” that is “contrary to constitutional right,” “in excess of statutory jurisdiction,” or “arbitrary and capricious.”

By contrast, where a patent holder merely challenges the Patent Office’s “determination that the information presented in the petition . . . shows that there is a reasonable likelihood” of success “with respect to at least 1 of the claims challenged,” § 314(a), or where a patent holder grounds its claim in a statute closely related to that decision to institute inter partes review, § 314(d) bars judicial review. In this case, Cuozzo’s claim that Garmin’s petition was not pleaded “with particularity” under § 312 is little more than a challenge to the Patent Office’s conclusion, under § 314(a), that the “information presented in the petition” warranted review. We therefore conclude that § 314(d) bars Cuozzo’s efforts to attack the Patent Office’s determination to institute inter partes review in this case.

...

For the reasons set forth above, we affirm the judgment of the Court of Appeals for the Federal Circuit.

*SAS Institute Inc. v. Iancu*  
138 S. Ct. 1348 (2018)

Justice GORSUCH delivered the opinion of the Court.

A few years ago Congress created “inter partes review.” The new procedure allows private parties to challenge previously issued patent claims in an adversarial process before the Patent Office that mimics civil litigation. Now we take up a question concerning the [inter partes review-implementing] statute’s operation. When the Patent Office initiates an inter partes review, must it resolve all of the claims in the case, or may it choose to limit its review to only some of them? The statute, we find, supplies a clear answer: the Patent Office must “issue a final written decision with respect to the patentability of *any patent claim challenged by the petitioner.*” 35 U.S.C. § 318(a). In this context, as in so many others, “any” means “every.” The agency cannot curate the claims at issue but must decide them all.



...

Our case arose when SAS sought an inter partes review of ComplementSoft's software patent. In its petition, SAS alleged that all 16 of the patent's claims were unpatentable for various reasons. The Director (in truth the Board acting on the Director's behalf) concluded that SAS was likely to succeed with respect to at least one of the claims and that an inter partes review was therefore warranted. But instead of instituting review on all of the claims challenged in the petition, the Director instituted review on only some (claims 1 and 3–10) and denied review on the rest. The Director did all this on the strength of a Patent Office regulation that purported to recognize a power of "partial institution," claiming that "when instituting inter partes review, the Director may authorize the review to proceed on all or some of the challenged claims and on all or some or the grounds of unpatentability asserted for each claim." 37 C.F.R. § 42.108(a). At the end of litigation, the Board issued a final written decision finding claims 1, 3, and 5–10 to be unpatentable while upholding claim 4. But the Board's decision did not address the remaining claims on which the Director had refused review.

That last fact led SAS to seek review in the Federal Circuit. There SAS argued that 35 U.S.C. § 318(a) required the Board to decide the patentability of every claim SAS challenged in its petition, not just some. For its part, the Federal Circuit rejected SAS's argument over a vigorous dissent by Judge Newman. We granted certiorari to decide the question ourselves.

We find that the plain text of § 318(a) supplies a ready answer. It directs that "if an inter partes review is instituted and not dismissed under this chapter, the Board *shall issue* a final written decision with respect to the patentability of *any patent claim challenged by the petitioner . . .*" § 318(a). This directive is both mandatory and comprehensive. The word "shall" generally imposes a nondiscretionary duty. And the word "any" naturally carries "an expansive meaning." When used (as here) with a "singular noun in affirmative contexts," the word "any" ordinarily "refers to a member of a particular group or class without distinction or limitation" and in this way "implies every member of the class or group." So when § 318(a) says the Board's final written decision "shall" resolve the patentability of "any patent claim challenged by the petitioner," it means the Board *must* address every claim the petitioner has challenged.

That would seem to make this an easy case. Where a statute's language carries a plain meaning, the duty of an administrative agency is to follow its commands as written, not to supplant those commands with others it may prefer. Because SAS challenged all 16 claims of ComplementSoft's patent, the Board in its final written decision had to address the patentability of all 16 claims. Much as in the civil litigation system it mimics, in an inter partes review the petitioner is master of its complaint and normally entitled to

judgment on all of the claims it raises, not just those the decisionmaker might wish to address.

The Director replies that things are not quite as simple as they seem. Maybe the Board has to decide every claim challenged by the petitioner in an inter partes review. But, he says, that doesn't mean every challenged claim gains admission to the review process. In the Director's view, he retains discretion to decide which claims make it into an inter partes review and which don't. The trouble is, nothing in the statute says anything like that. The Director's claimed "partial institution" power appears nowhere in the text of § 318, or anywhere else in the statute for that matter. And what can be found in the statutory text and context strongly counsels against the Director's view.

Start where the statute does. In its very first provision, the statute says that a party may seek inter partes review by filing "a petition to institute an inter partes review." § 311(a). This language doesn't authorize the Director to start proceedings on his own initiative. Nor does it contemplate a petition that asks the Director to initiate whatever kind of inter partes review he might choose. Instead, the statute envisions that a petitioner will seek an inter partes review of a particular kind—one guided by a petition describing "each claim challenged" and "the grounds on which the challenge to each claim is based." § 312(a)(3). From the outset, we see that Congress chose to structure a process in which it's the petitioner, not the Director, who gets to define the contours of the proceeding. And "just as Congress' choice of words is presumed to be deliberate" and deserving of judicial respect, "so too are its structural choices."

It's telling, too, to compare this structure with what came before. In the ex parte reexamination statute, Congress embraced an inquisitorial approach, authorizing the Director to investigate a question of patentability "on his own initiative, and at any time." § 303(a). If Congress had wanted to give the Director similar authority over the institution of inter partes review, it knew exactly how to do so—it could have simply borrowed from the statute next door. But rather than create (another) agency-led, inquisitorial process for reconsidering patents, Congress opted for a party-directed, adversarial process. Congress's choice to depart from the model of a closely related statute is a choice neither we nor the agency may disregard.

More confirmation comes as we move to the point of institution. Here the statute says the Director must decide "whether to institute an inter partes review pursuant to a petition." § 314(b). The Director, we see, is given only the choice "whether" to institute an inter partes review. That language indicates a binary choice—either institute review or don't. And by using the term "pursuant to," Congress told the Director what he must say yes or no to: an inter partes review that proceeds "in accordance with" or "in conformance to" the petition. Nothing suggests the Director enjoys a license to depart from the petition and institute a *different* inter partes review of his own design.

To this the Director replies by pointing to another part of § 314. Section 314(a) provides that the Director may not authorize an inter partes review unless he determines “there is a reasonable likelihood” the petitioner will prevail on “at least 1 of the claims challenged in the petition.” The Director argues that this language requires him to “evaluate claims individually” and so must allow him to institute review on a claim-by-claim basis as well. But this language, if anything, suggests just the opposite. Section 314(a) does not require the Director to evaluate every claim individually. Instead, it simply requires him to decide whether the petitioner is likely to succeed on “at least 1” claim. Once that single claim threshold is satisfied, it doesn’t matter whether the petitioner is likely to prevail on any *additional* claims; the Director need not even consider any other claim before instituting review. Rather than contemplate claim-by-claim institution, then, the language anticipates a regime where a reasonable prospect of success on a single claim justifies review of all.

Here again we know that if Congress wanted to adopt the Director’s approach it knew exactly how to do so. The ex parte reexamination statute allows the Director to assess whether a request raises “a substantial new question of patentability affecting any claim” and (if so) to institute reexamination limited to “resolution of *the question*.” § 304. In other words, that statute allows the Director to institute proceedings on a claim-by-claim and ground-by-ground basis. But Congress didn’t choose to pursue that known and readily available approach here. And its choice to try something new must be given effect rather than disregarded in favor of the comfort of what came before.

Faced with this difficulty, the Director tries another tack. He points to the fact that § 314(a) doesn’t *require* him to institute an inter partes review even after he finds the “reasonable likelihood” threshold met with respect to one claim. Whether to institute proceedings upon such a finding, he says, remains a matter left to his discretion. See *Cuozzo*. But while § 314(a) invests the Director with discretion on the question *whether* to institute review, it doesn’t follow that the statute affords him discretion regarding *what* claims that review will encompass. The text says only that the Director can decide “whether” to institute the requested review—not “whether *and to what extent*” review should proceed. § 314(b).

The rest of the statute confirms, too, that the petitioner’s petition, not the Director’s discretion, is supposed to guide the life of the litigation. For example, § 316(a)(8) tells the Director to adopt regulations ensuring that, “after an inter partes review has been instituted,” the patent owner will file “a response to the petition.” Surely it would have made little sense for Congress to insist on a response to the petition if, in truth, the Director enjoyed the discretion to limit the claims under review. What’s the point, after all, of answering claims that aren’t in the proceeding? If Congress had meant to afford the Director the power he asserts, we would have expected it to instruct him to adopt regulations requiring the patent owner to file a response *to the Director’s institution notice*

or to the claims on which the Director instituted review. Yet we have nothing like that here. And then and again there is § 318(a). At the end of the proceeding, § 318(a) categorically commands the Board to address in its final written decision “any patent claim challenged by the petitioner.” In all these ways, the statute tells us that the petitioner’s contentions, not the Director’s discretion, define the scope of the litigation all the way from institution through to conclusion.

The Director says we can find at least some hint of the discretion he seeks by comparing § 314(a) and § 318(a). He notes that, when addressing whether to institute review at the beginning of the litigation, § 314(a) says he must focus on the claims found “in the petition”; but when addressing what claims the Board must address at the end of the litigation, § 318(a) says it must resolve the claims challenged “by the petitioner.” According to the Director, this (slight) linguistic discrepancy means the claims the Board must address in its final decision are not necessarily the same as those identified in the petition. And the only possible explanation for this arrangement, the Director submits, is that he must enjoy the (admittedly implicit) power to institute an inter partes review that covers fewer than all of the claims challenged in the petition.

We just don’t see it. Whatever differences they might display, § 314(a) and § 318(a) both focus on the *petitioner’s* contentions and, given that, it’s difficult to see how they might be read to give the *Director* power to decide what claims are at issue. Particularly when there’s a much simpler and sounder explanation for the statute’s wording. As we’ve seen, a patent owner may move to “cancel any challenged patent claim” during the course of an inter partes review, effectively conceding one part of a petitioner’s challenge. § 316(d)(1)(A). Naturally, then, the claims challenged “in the petition” will not always survive to the end of the case; some may drop out thanks to the patent owner’s actions. And in that light it is plain enough why Congress provided that only claims still challenged “by the petitioner” at the litigation’s end must be addressed in the Board’s final written decision. The statute’s own winnowing mechanism fully explains why Congress adopted slightly different language in § 314(a) and § 318(a). We need not and will not invent an atextual explanation for Congress’s drafting choices when the statute’s own terms supply an answer.

Moving past the statute’s text and context, the Director attempts a policy argument. He tells us that partial institution is efficient because it permits the Board to focus on the most promising challenges and avoid spending time and resources on others. SAS responds that all patent challenges usually end up being litigated *somewhere*, and that partial institution creates inefficiency by requiring the parties to litigate in two places instead of one—the Board for claims the Director chooses to entertain and a federal court for claims he refuses. Indeed, SAS notes, the government itself once took the same view, arguing that partial institution “undermines the Congressional efficiency goal” for this

very reason. Each side offers plausible reasons why its approach might make for the more efficient policy. But who should win that debate isn't our call to make. Policy arguments are properly addressed to Congress, not this Court. It is Congress's job to enact policy and it is this Court's job to follow the policy Congress has prescribed. And whatever its virtues or vices, Congress's prescribed policy here is clear: the petitioner in an inter partes review is entitled to a decision on all the claims it has challenged.\*

\* Justice GINSBURG suggests the Director might yet avoid this command by refusing to review a petition he thinks too broad while signaling his willingness to entertain one more tailored to his sympathies. We have no occasion today to consider whether this stratagem is consistent with the statute's demands. *See Cuozzo* (noting that courts may invalidate "shenanigans" by the Director that are "outside his statutory limits"). But even assuming (without granting) the law would tolerate this tactic, it would show only that a lawful means exists for the Director to achieve his policy aims—not that he "should be allowed to improvise on the powers granted by Congress" by devising an extralegal path to the same goal. That an agency's improvisation might be thought by some more expedient than what the law allows does nothing to commend it either, for lawful ends do not justify unlawful means.

That leaves the Director to suggest that, however this Court might read the statute, he should win anyway because of *Chevron U.S.A. Inc. v. Natural Resources Defense Council, Inc.*, 467 U.S. 837 (1984). Even though the statute says nothing about his asserted "partial institution" power, the Director says the statute is at least ambiguous on the propriety of the practice and so we should leave the matter to his judgment. For its part, SAS replies that we might use this case as an opportunity to abandon *Chevron* and embrace the "'impressive body'" of pre-*Chevron* law recognizing that "the meaning of a statutory term" is properly a matter for "judicial rather than administrative judgment."

But whether *Chevron* should remain is a question we may leave for another day. Even under *Chevron*, we owe an agency's interpretation of the law no deference unless, after "employing traditional tools of statutory construction," we find ourselves unable to discern Congress's meaning. And after applying traditional tools of interpretation here, we are left with no uncertainty that could warrant deference. The statutory provisions before us deliver unmistakable commands. The statute hinges inter partes review on the filing of a petition challenging specific patent claims; it makes the petition the centerpiece of the proceeding both before and after institution; and it requires the Board's final written decision to address every claim the petitioner presents for review. There is no room in this scheme for a wholly unmentioned "partial institution" power that lets the Director select only some challenged claims for decision. The Director may (today) think his approach makes for better policy, but policy considerations cannot create an ambiguity when the

words on the page are clear. Neither may we defer to an agency official's preferences because we imagine some "hypothetical reasonable legislator" would have favored that approach. Our duty is to give effect to the text that 535 *actual* legislators (plus one President) enacted into law.

At this point, only one final question remains to resolve. Even if the statute forbids his partial institution practice, the Director suggests we lack the power to say so. By way of support, he points to § 314(d) and our decision in *Cuozzo*. Section 314(d) says that the "determination by the Director whether to institute an inter partes review under this section shall be final and nonappealable." In *Cuozzo*, we held that this provision prevented courts from entertaining an argument that the Director erred in instituting an inter partes review of certain patent claims. The Director reads these authorities as foreclosing judicial review of any legal question bearing on the institution of inter partes review—including whether the statute permits his "partial institution" practice.

But this reading overreads both the statute and our precedent. As *Cuozzo* recognized, we begin with "the 'strong presumption' in favor of judicial review." To overcome that presumption, *Cuozzo* explained, this Court's precedents require "clear and convincing indications" that Congress meant to foreclose review. Given the strength of this presumption and the statute's text, *Cuozzo* concluded that § 314(d) precludes judicial review only of the Director's "initial determination" under § 314(a) that "there is a 'reasonable likelihood' that the claims are unpatentable on the grounds asserted" and review is therefore justified. In fact, *Cuozzo* proceeded to emphasize that § 314(d) does not "enable the agency to act outside its statutory limits." If a party believes the Patent Office has engaged in "'shenanigans'" by exceeding its statutory bounds, judicial review remains available consistent with the Administrative Procedure Act, which directs courts to set aside agency action "not in accordance with law" or "in excess of statutory jurisdiction, authority, or limitations." *Ibid.*; 5 U.S.C. §§ 706(2)(A), (C).

And that, of course, is exactly the sort of question we are called upon to decide today. SAS does not seek to challenge the Director's conclusion that it showed a "reasonable likelihood" of success sufficient to warrant "instituting an inter partes review." 35 U.S.C. §§ 314(a), (d). No doubt SAS remains very pleased with the Director's judgment on that score. Instead, SAS contends that the Director exceeded his statutory authority by limiting the review to fewer than all of the claims SAS challenged. And nothing in § 314(d) or *Cuozzo* withdraws our power to ensure that an inter partes review proceeds in accordance with the law's demands.

Because everything in the statute before us confirms that SAS is entitled to a final written decision addressing all of the claims it has challenged and nothing suggests we lack the power to say so, the judgment of the Federal Circuit is reversed and the case is remanded for further proceedings consistent with this opinion.

Justice GINSBURG, with whom Justice BREYER, Justice SOTOMAYOR, and Justice KAGAN join, dissenting.

Given the Court’s wooden reading of 35 U.S.C. § 318(a), and with “no mandate to institute inter partes review” at all, *Cuozzo Speed Technologies, LLC v. Lee*, 136 S. Ct. 2131, 2140, (2016), the Patent Trial and Appeal Board could simply deny a petition containing challenges having no “reasonable likelihood” of success, § 314(a). Simultaneously, the Board might note that one or more specified claims warrant reexamination, while others challenged in the petition do not. Petitioners would then be free to file new or amended petitions shorn of challenges the Board finds unworthy of inter partes review. Why should the statute be read to preclude the Board’s more rational way to weed out insubstantial challenges? . . . [T]he Court’s opinion offers no persuasive answer to that question, and no cause to believe Congress wanted the Board to spend its time so uselessly.

Justice BREYER, with whom Justice GINSBURG and Justice SOTOMAYOR join, and with whom Justice KAGAN joins except as to Part III–A, dissenting.

This case requires us to engage in a typical judicial exercise, construing a statute that is technical, unclear, and constitutes a minor procedural part of a larger administrative scheme. I would follow an interpretive technique that judges often use in such cases. Initially, using “traditional tools of statutory construction,” I would look to see whether the relevant statutory phrase is ambiguous or leaves a gap that Congress implicitly delegated authority to the agency to fill. *Chevron U.S.A. Inc. v. Natural Resources Defense Council, Inc.*, 467 U.S. 837, 842–843 (1984). If so, I would look to see whether the agency’s interpretation is reasonable. *Id.* at 843.

...

Section 318(a) contains a gap just after the words “challenged by the petitioner.” Considerations of context, structure, and purpose do not close the gap. And under *Chevron*, “where a statute leaves a ‘gap’ or is ‘ambiguous,’ we typically interpret it as granting the agency leeway to enact rules that are reasonable in light of the text, nature, and purpose of the statute.” *Cuozzo*, 136 S. Ct. at 2142.

...

In addition, the agency filled the gap here through the exercise of rulemaking authority explicitly given it by Congress to issue regulations “setting forth the standards for the showing of sufficient grounds to institute a review” and “establishing and governing inter partes review.” §§ 316(a)(2), (4); *Cuozzo*, 136 S. Ct., at 2142–42. . . . [A]nd it filled the gap with a regulation that, for reasons I have stated, is a reasonable exercise of that authority.

I consequently would affirm the judgment of the Federal Circuit. And, with respect, I dissent from the Court's contrary conclusion.

## D. Post-Issuance Review and Correction

### 1. Certificates of Correction and Reissue

*Superior Fireplace Co. v. Majestic Products Co.*  
270 F.3d 1358 (Fed. Cir. 2001)

LINN, Circuit Judge.

Superior Fireplace Co. ("Superior") appeals a final judgment from the United States District Court for the Central District of California. The district court determined, on summary judgment, that Superior's certificate of correction for United States Patent No. 5,678,534 ("534 patent") is invalid and that the uncorrected '534 patent is not infringed by Majestic Products Co. and Vermont Castings, Inc. (collectively, "Majestic").

...

#### *The '534 Patent*

The '534 patent relates to gas fireplace technology. . . .

...

Claim 1 of the '534 patent is the only claim at issue in this appeal and reads as follows:

1. A gas log fireplace comprising in combination:

a housing having a top wall, bottom wall, side walls and a rear wall;

a firebox within the housing comprising a top wall, *rear walls* and side walls, said firebox forming a primary combustion chamber;

a room air plenum comprising a top room air plenum between the top wall of the firebox and the top wall of the housing, a rear room air plenum between the rear wall of the firebox and the rear wall of the housing in communication with the top room air plenum;

an inlet opening for allowing room air to enter the rear room air plenum;

an outlet opening in communication with the top room air plenum for allowing room air and exhaust products in the top room air plenum to be exhausted into a room in which the fireplace is situated;



## DESIGNS

an intake opening into the firebox for receiving room air into the primary combustion chamber;

a burner within the firebox, at least one artificial log within the firebox adjacent to said burner and means for supporting said at least one log within the firebox;

means for delivering a source of combustible gas to the burner;

an exhaust opening in the top wall of the firebox;

a catalytic converter positioned in the exhaust opening of the firebox and forming a secondary combustion chamber; and

whereby exhaust products from the primary combustion chamber are received by the catalytic converter wherein secondary combustion takes place and the exhaust products from the secondary combustion chamber are received by the top room air plenum and are mixed with room air received by the rear room air plenum and exhausted into the room in which the fireplace is situated.

The dispute in this appeal focuses on the emphasized term “rear walls,” in the firebox limitation above. This plural term was changed to the singular term “rear wall” in Superior’s certificate of correction . . . .

In the course of prosecuting the [original] patent application, Superior submitted an amendment adding a new claim that eventually issued as claim 1. This claim initially recited “rear wall” in the firebox limitation.

. . .

On March 6, 1997, the examiner and a representative for Superior followed up [an] earlier meeting with a telephonic interview. This interview was also memorialized with an “Examiner Interview Summary Record,” mailed on March 11, 1997, in which the examiner stated that the claim in question would be modified “as set forth in the attached examiner’s amendment.” That amendment shows, among other changes, that “rear wall” was amended to “rear walls.” A “Notice of Allowability” was also mailed on March 11, 1997, thus indicating that the amended claim—with the revised expression “rear walls”—was allowable.

The examiner’s amendment also reminded Superior that “should the changes and/or additions be unacceptable to applicant, an amendment may be filed.” Superior did submit an amendment under 37 C.F.R. § 1.312 (“section 312 amendment”) three months later, on June 11, 1997, . . . [but] did not amend the claim term “rear walls,” and Superior submitted no further amendment before issuance. Consequently, the ’534 patent issued with the term “rear walls” on October 21, 1997. After the patent issued, Superior identified another nine errors and, on August 28, 1998, submitted a “Make-of-Record Letter” noting these

errors. The “Make-of-Record Letter” did not list any amendments to the claim term “rear walls.”

*Procedural History of Litigation*

On March 12, 1998, Superior filed a complaint against Majestic for infringement of the '534 patent. At some time after this, Majestic pointed out that the second limitation of claim 1 recited “rear walls.” Superior then proceeded to apply for a certificate of correction from the Patent and Trademark Office (“PTO”), seeking to change the claim term from “rear walls” to “rear wall.”

. . . The PTO granted this request, issuing a certificate of correction on August 17, 1999. We note that both requests were filed and the certificate was granted less than two years after the '534 patent issued. Accordingly, Superior was within the two-year window for broadening reissues under 35 U.S.C. § 251, had it elected to pursue that route.

The parties filed summary judgment motions and the district court determined that the certificate of correction issued by the PTO was invalid. The district court found, and it is not disputed on appeal, that both parties agreed that the accused devices do not contain more than one rear wall and that there can be no literal infringement if the claim is construed to require two or more rear walls. . . . [Additionally], the district court determined that there was no infringement under the DOE. Neither of the noninfringement findings are directly challenged on appeal, nor is the construction of the uncorrected claim. Thus, if we affirm the district court’s decision that the certificate is invalid, then noninfringement must follow.

*Burden of Persuasion*

Challenges to the validity of claims, whether regularly issued, issued after a reexamination pursuant to 35 U.S.C. §§ 301–307, or issued after a reissue pursuant to 35 U.S.C. §§ 251–252, must meet the clear and convincing standard of persuasion. This requirement is based on the presumption of validity.<sup>1</sup>

<sup>1</sup> Additionally, this court has noted previously that the imposition of this standard is related to the presumption that the PTO does its job properly. We observe that the PTO is presumed to have done its job in this case with regard to Superior’s certificate of correction.

As explained above, the present challenge is a challenge to the validity of the certificate of correction. But since the effect of that challenge in the present case is to challenge the validity of a claim, the clear and convincing standard applicable under our precedent to other validity challenges should also apply to the present challenge to the validity of the certificate of correction.

## DESIGNS

### *Review of a "Clerical or Typographical Nature"*

The phrase "clerical or typographical nature" is not explicitly defined in § 255, so we first look to the plain meaning and common understanding of the phrase. A standard dictionary defines "clerical" as relating to an office clerk or office work, and defines "typographical" as relating to the setting of type, printing with type, or the arrangement of matter printed from type. Thus, clerical or typographical mistakes are generally understood to include simple mistakes such as obvious misspellings that are immediately apparent. Upon viewing such a misspelling, there is no doubt that a mistake, indeed a clerical or typographical mistake, has occurred.

The parties dispute whether a § 255 clerical or typographical mistake may ever encompass a mistake that, upon correction, would broaden a claim. The common understanding of a clerical or typographical mistake certainly includes mistakes that, upon correction, would either broaden or narrow a claim. Majestic suggests, however, that a claim may only be broadened under the reissue provisions of 35 U.S.C. § 251. We acknowledge that Congress dealt with broadening reissues in detail in § 251 and that our interpretation of § 255 must consider the entire statutory scheme, including § 251. Although § 255, unlike § 251, does not expressly deal with broadening corrections, the words of § 255 do not preclude broadening corrections. We are hesitant to impose so great a limitation without express indication from the statute. Accordingly, we interpret § 255 to allow broadening corrections of clerical or typographical mistakes.

The parties also dispute whether a § 255 clerical or typographical mistake, the correction of which would broaden a claim, must be evident from the public record. This question arises from the observation that not all clerical or typographical mistakes are immediately apparent, and even where the mistake is apparent, it may not be clear how the mistake should be corrected. This leads to a classification of these typographical mistakes into three categories. Some mistakes are immediately apparent and leave no doubt as to what the mistake is. Examples of such errors include misspellings that leave no doubt as to the word which was intended; "frane" instead of "frame," for example. In contrast, a second category includes those typographical mistakes not apparent to the reader at all; for example, a mistake resulting in another word that is spelled correctly and that reads logically in the context of the sentence. A third category of mistakes includes those where it is apparent that a mistake has been made, but it is unclear what the mistake is. Examples of such mistakes are those that create inconsistent terms, but leave unclear which of the conflicting terms is in error. It is not evident to the reader of the public record how to appropriately correct mistakes of the second and third categories.

To help resolve which, if any, of these three categories of mistakes may be corrected under § 255, we again "consider not only the bare meaning of the words of § 255 but also their placement and purpose in the statutory scheme." The statutory scheme here

encompasses 35 U.S.C. §§ 251–256, which govern the amendment and correction of patents. . . .

Section 251 addresses the correction of an “error” and it is understood that corrections under § 251 can result in the broadening of a claim. 35 U.S.C. § 251 (allowing correction of an error in which “the patentee claimed less than he had a right to claim”). The patentee’s right to broaden a claim is not absolute, however. First, § 251 requires that the broadened claim be supported by the original specification. *Id.* (allowing a reissue only “for the invention disclosed in the original patent”). Second, § 251 precludes a patentee from applying for a broadening reissue more than two years after a patent has issued. 35 U.S.C. § 251 (“No reissued patent shall be granted enlarging the scope of the claims of the original patent unless applied for within two years from the grant of the original patent.”). Third, and most important for our analysis, Congress further protected the public by providing intervening rights for the public with respect to claims that were broadened under § 251. 35 U.S.C. § 252 (providing intervening rights).

. . .

Having already determined that broadening corrections are encompassed in § 255, at least in certain circumstances, it is here that we place the weight of § 251 and § 252. Sections 251 and 252 evince the clear intent of Congress to protect the public against the unanticipated broadening of a claim after the grant of the patent by the PTO. It would be inconsistent with that objective to interpret § 255 to allow a patentee to broaden a claim due to the correction of a clerical or typographical mistake that the public could not discern from the public file and for which the public therefore had no effective notice. Such a broadening correction would leave the public without effective notice, without the constraint of a two-year time bar, and without the hope of intervening rights.

. . . Both the Supreme Court and this court have highlighted the importance of the notice function of patent claims. *Warner–Jenkinson Co. v. Hilton Davis Chem. Co.*, 520 U.S. 17, 29 (1997) (discussing the impact of the doctrine of equivalents on “the definitional and public-notice functions of the statutory claiming requirement”); *Festo Corp. v. Shoketsu Kinzoku Kogyo Kabushiki Co., Ltd.*, 234 F.3d 558, 575 (Fed. Cir. 2000) (*en banc*) (stating that “the notice function of patent claims has become paramount”), *cert. granted*, 533 U.S. 915 (2001). Placing due weight on the public notice function of patent claims suggests that we should interpret § 255 to allow a broadening correction of a typographical error only where it is clearly evident from the specification, drawings, and prosecution history how the error should appropriately be corrected. Such an interpretation of § 255 insures that the public is provided with notice as to the scope of the claims. . . .

. . .

## DESIGNS

We now review the district court's summary judgment decision that the alleged "rear walls" mistake was not of a clerical or typographical nature. Applying the clear and convincing evidence standard to this validity challenge, we must affirm the district court's holding if we find the absence of a genuine issue that the appropriate correction of the alleged "rear walls" mistake was not clearly evident from the intrinsic record. The intrinsic record, that is, the public record, consists of the original and corrected claims, the written description and drawings, and the prosecution history.

The claim language in question recites "a firebox within the housing comprising a top wall, rear walls and side walls." There is no grammatical error that suggests a mistake. The next limitation in the claim, however, refers to "the rear wall of the firebox." Because that limitation refers to rear wall in the singular, with the definite article "the," it does not agree with the earlier reference to rear walls in the plural. One of these limitations contains a mistake, but the claim does not indicate which is mistaken.

...

... [T]he prosecution history provides compelling evidence that "rear walls" was the correct phrase. Thus, the requested correction of the alleged mistake was not apparent from the specification, drawings, and prosecution history. The alleged mistake is, therefore, not a clerical or typographical mistake correctable under § 255. . . .

### *Review of "Minor Character"*

We begin by interpreting the § 255 phrase "minor character." This phrase is not explicitly defined in the statute, and so we begin with the plain meaning of the phrase. "Minor" is commonly defined as "lesser in importance or seriousness." The scope of a patent claim is its very essence, and that with which the patentee and any competitors are most concerned. A mistake that, if corrected, would broaden the scope of a claim must thus be viewed as highly important and thus cannot be a mistake of "minor character." Accordingly, based on the plain meaning of the statutory language, we interpret "a mistake of minor character" to exclude mistakes that broaden a claim.

In the relevant claim limitation, the corrected claim recites only "rear wall" (singular), whereas the uncorrected claim recited "rear walls" (plural). The district court held, and Superior does not dispute, that the corrected claim is broader than the uncorrected claim, if both are properly construed in accordance with our case law. . . .

...

... [Therefore,] we conclude as a matter of law that it was not correctable by a certificate of correction under 35 U.S.C. § 255.

## CHAPTER 12

### *Conclusion*

Because the correction of the alleged mistake under § 255 broadened a claim and was not clearly evident from the specification, drawings, and prosecution history, we affirm the district court's summary judgment that Superior's certificate of correction is invalid.

...

DYK, Circuit Judge, dissenting.

I agree with the majority that the PTO's action in granting the certificate of correction is entitled to a presumption of validity that must be overcome with clear and convincing evidence. I also agree that the PTO is authorized, under 35 U.S.C. § 255, to issue certificates of correction for typographical or clerical mistakes that broaden the scope of the patent, for I share the majority's hesitancy to interpret section 255 to prohibit broadening corrections "without express indication from the statute." However, I part company with the majority when it reads into the statute a requirement that the error be apparent from the prosecution history, a requirement which is equally lacking an "express indication" in the statute. I accordingly dissent from the majority's holding that the certificate of correction is invalid and from the majority's decision affirming the grant of summary judgment of non-infringement.

*Mentor Corp. v. Coloplast Inc.*  
998 F.2d 992 (Fed. Cir. 1993)

LOURIE, Circuit Judge.

Following a March 1992 jury verdict, judgment was entered against Coloplast, Inc., holding, *inter alia*, that all the original and reissued claims of Mentor Corporation's U.S. Patent Re. 33,206 were willfully infringed [and] that the '206 patent was not invalid . . . . Coloplast appeals on the issues of validity and infringement. . . .

### *Background*

In July 1989, Mentor sued Coloplast for infringement of U.S. Patent 4,475,910, entitled "Male Condom Catheter Having Adhesive on Rolled Portion." While the lawsuit was pending, it was reissued as the '206 patent and Coloplast filed a separate suit for a declaration of invalidity, unenforceability, and noninfringement of that patent. Mentor amended its complaint in the original action to allege infringement of the '206 patent and the two cases were consolidated.

The claimed invention relates to a condom catheter which is used on male patients suffering from incontinence. Claims 1-4 of the '206 patent recite a catheter having a pressure sensitive adhesive on a non-stick (release) layer located on the outer surface of a

## DESIGNS

condom sheath prior to it being rolled up, such that on rolling the sheath outwardly, the adhesive on the outer surface comes into contact with and sticks to the inner surface. When unrolled, the adhesive which was initially applied to the release layer on the outer surface is thereby transferred to the inner surface.

...

Claims 6–9, which were added during reissue, do not recite the transfer of adhesive from the outer to the inner surface of the catheter.

...

Coloplast sells the Coloplast Self Sealing Urosheath, which is made by applying adhesive directly to the inner surface, the outer surface being coated with a non-stick, release layer. Use of the Coloplast device does not involve the transfer of adhesive from the outer to the inner surface. . . .

### *Discussion*

Coloplast argues that claims 6–9 of the reissue patent are invalid because they are not based on “error” within the meaning of 35 U.S.C. § 251 . . . . Coloplast argues that Mentor deliberately and intentionally amended its claims in response to a prior art rejection and that such conduct is not reissuable error. Thus, it asserts, the court erred as a matter of law. We agree.

...

Section 251 provides in pertinent part:

Whenever any patent is, through error without any deceptive intention, deemed wholly or partly inoperative or invalid, by reason of a defective specification or drawing, or by reason of the patentee claiming more or less than he had a right to claim in the patent, the Commissioner shall . . . reissue the patent for the invention disclosed in the original patent, and in accordance with a new and amended application, for the unexpired part of the term of the original patent.

Reissue “error” is generally liberally construed, and we have recognized that “an attorney’s failure to appreciate the full scope of the invention” is not an uncommon defect in claiming an invention. However, the reissue procedure does not give the patentee “a second opportunity to prosecute de novo his original application.”

...

If a patentee tries to recapture what he or she previously surrendered in order to obtain allowance of original patent claims, that “deliberate withdrawal or amendment cannot be said to involve the inadvertence or mistake contemplated by 35 U.S.C. § 251,

and is not an error of the kind which will justify the granting of a reissue patent which includes the matter withdrawn." "The recapture rule bars the patentee from acquiring, through reissue, claims that are of the *same* or of *broader scope* than those claims that were cancelled from the original application." The recapture rule does not apply where there is no evidence that amendment of the originally filed claims was in any sense an admission that the scope of that claim was not in fact patentable, but that is not the situation here.

During prosecution of the original patent application, the examiner rejected claim 1 as unpatentable over U.S. Patent 4,187,851 to Hauser in view of U.S. Patent 2,389,831 to Welsh and U.S. Patent 3,403,682 to McDonell. According to the examiner, Hauser lacked the positioning of an adhesive means between the rolls, which was taught by Welsh and McDonell. Mentor responded by replacing claim 1, which did not require "transfer" of adhesive from an outer layer to an inner layer, with a new claim 7, which read in part as follows:

A male condom catheter comprising a thin cylindrical sheath member having an outer surface and an inner surface and the outer surface of the sheath member having a layer of pressure sensitive adhesive over a substantial portion thereof with a release layer between said adhesive and the outer surface of the sheath member so that as the sheath member is unrolled the adhesive on the outer surface *is transferred* to the [portion] of the inner surface in engagement with the outer surface to cause the inner surface to adhere to the penis over which the sheath is placed.

The claims were again rejected under 35 U.S.C. § 103 as unpatentable over McDonell in view of Welsh. The examiner stated that McDonell disclosed a male catheter with a sheath having an outer surface with adhesive and a release layer, and that Welsh showed a sheath with adhesive, which when unrolled was transferred from the outer surface to the inner surface. In response, Mentor further amended claim 7 to recite that as the sheath member is "rolled up the pressure sensitive adhesive on the outer surface is in direct contact with the inner surface of an adjacent roll so that as the sheath member is unrolled, the adhesive on the outer surface is *transferred without rolling the catheter inside out . . .*" Mentor argued that "none of the references relied upon actually showed the *transfer of adhesive* from the outer surface to the inner surface as the sheath is rolled up and then unrolled." Mentor characterized the prior art references as disclosing the "transfer" of adhesive from the outer to the inner surface solely by turning the sheath inside out so that the outer surface becomes the inner surface and the adhesive always remains on the same surface. Amended claim 7 then issued as claim 1 as a result of Mentor's amendments and argument.

...



Coloplast correctly argues that reissue claim 6, which does not include the adhesive transfer limitation, impermissibly recaptures what Mentor deliberately surrendered in the original prosecution. Specifically, the reissue claims do not contain the limitation that, during rolling and unrolling, the adhesive be transferred from the outer to the inner surface of the catheter.

Error under the reissue statute does not include a deliberate decision to surrender specific subject matter in order to overcome prior art, a decision which in light of subsequent developments in the marketplace might be regretted. It is precisely because the patentee amended his claims to overcome prior art that a member of the public is entitled to occupy the space abandoned by the patent applicant. Thus, the reissue statute cannot be construed in such a way that competitors, properly relying on prosecution history, become patent infringers when they do so. In this case, Mentor narrowed its claims for the purpose of obtaining allowance in the original prosecution and it is now precluded from recapturing what it earlier conceded.

Mentor argues that the reissue claims do not recapture subject matter surrendered during the original prosecution. Mentor specifically alleges that recapture is avoided because newly-added reissue claims 6–9 are materially narrower in some respects, albeit broader in others.

Reissue claims that are broader in certain respects and narrower in others may avoid the effect of the recapture rule. If a reissue claim is broader in a way that does not attempt to reclaim what was surrendered earlier, the recapture rule may not apply. However, in this case, the reissue claims are broader than the original patent claims in a manner directly pertinent to the subject matter surrendered during prosecution. Mentor thus attempted to reclaim what it earlier gave up. Moreover, the added limitations do not narrow the claims in any material respect compared with their broadening.

The limitation in claim 6 that the catheter material be “flexible” did not materially narrow the claims, which already recited that the material be “resilient.” Likewise, the limitation that the catheter be rolled outward to form a “single” roll did not materially limit the claims; the catheter can only be rolled and applied from a single end to form a single roll when the other end is connected to a urine collection means. Further, the addition of the words “thereon,” referring to the location of the adhesive release layer on the outer surface prior to unrolling, and “only,” referring to the adhering of the adhesive to the inner surface after unrolling, did not materially narrow the claims.

Additionally, claims 7–9, which depend from claim 6, do not avoid recapture because they do not add any limitations, material in relation to the impermissible broadening, that distinguish them over claim 6, which we have determined is not a proper subject for reissue. . . .

Thus, since none of reissue claims 6–9 meets the legal requirements for reissue, the court erred in denying the motion for judgment of invalidity as a matter of law. We therefore reverse that part of the court's judgment finding claims 6–9 not invalid. . . .

*Seattle Box Co., Inc. v. Industrial Crating & Packing, Inc.*  
756 F.2d 1574 (1985)

DAVIS, Circuit Judge.

This appeal is from a decision, on remand from this court, of the United States District Court for the Western District of Washington, which declined to accord appellants any intervening rights under 35 U.S.C. § 252 as to certain infringing products. We . . . reverse [the denial of intervening rights].

I

Seattle Box Company (Seattle Box) and Industrial Crating and Packing, Inc. (Industrial) both provide oil pipe bundling services to oil companies. Seattle Box initiated the present action against Industrial on July 2, 1980, alleging the infringement of U.S. Patent No. 4,099,617 ('617) entitled "Shipping Bundle for Numerous Pipe Lengths." On August 19, 1980, Seattle Box was granted reissue of the '617 patent in U.S. Patent No. Re 30,373 (Re '373). Consequently, on October 10, 1980, Seattle Box amended its complaint, alleging infringement of the Re '373 patent.

Briefly, the patented invention defines a system of stacking ("bundling") tiers of pipes across parallel horizontal beams or sleepers. [These are separated by spacer blocks.] Claim 1 of the '617 patent required that a spacer block have a height "greater than the diameter of the pipe." However, in the Re '373 patent, claim 1 was amended to specify a spacer block "of a height *substantially equal to or* greater than the thickness of the tier of pipe length." (Emphasis in the claim.)

[Seattle Box sued Industrial, alleging that its production of two sets of bundles—one incorporating spacer blocks that were 1/16" shorter than the diameter of the pipes in question, and one incorporating spacer blocks that were 1/4" shorter than said diameter—infringed its patents.] . . . On the issues of validity and infringement, the district court held in favor of Seattle Box . . . [On the initial appeal, the Federal Circuit affirmed the validity findings.] But the district court's finding of liability for pipe bundling activities Industrial performed *before* the Re '373 patent issued was reversed because under the first paragraph of 35 U.S.C. § 252 the reissue claims were not "identical" to the original claims, and therefore infringement could only be asserted for the Re '373 patent and not the '617 patent. . . . Lastly, we vacated the district court's award of post-reissue damages for

## DESIGNS

infringement of the Re '373 patent, holding that the defense of intervening rights under the second paragraph of 35 U.S.C. § 252 was properly raised. . . .

On June 12, 1984, the district court held a hearing on the matters remanded from this court. As to the 84 bundles made with spacer blocks  $\frac{1}{4}$  inch less than the pipe diameter, the district court held that these bundles did not infringe the Re '373 patent. Supporting its assertion that the doctrine of intervening rights applies to the post-reissue bundles (there are 919 bundles in issue), Industrial presented the affidavit testimony of Vernon Zier, Industrial's in-house accountant, who summarized Industrial's business records. Zier averred that on August 19, 1980 (the date of the Re '373 patent), there were orders for 114 bundles which were subsequently completed after that date. In addition, Industrial's inventory of spacer blocks on August 19, 1980 was sufficient to make 224 bundles (this figure incorporates the orders for the 114 bundles). Seattle Box has not contested these facts.

After considering Industrial's argument . . . , the district court merely stated in its final order on July 19, 1982 that:

The 224 bundles were made after the grant of plaintiff's reissue patent. Defendant has failed to persuade the court that good and valid reasons exist for the court to exercise its discretionary powers in favor of the Defendant as to intervening rights. The Court therefore declines to exercise its discretion in according any intervening rights as to the 224 bundles.

It is from this order and the ensuing judgment that Industrial appeals.

### III

The doctrine of intervening rights finds its roots in the second paragraph of 35 U.S.C. § 252:

(1) No reissued patent shall abridge or affect the right of any person or his successors in business who made, purchased or used prior to the grant of a reissue anything patented by the reissued patent, to continue the use of, or to sell to others to be used or sold, the specific thing so made, purchased or used, unless the making, using or selling of such thing infringes a valid claim of the reissued patent which was in the original patent. (2) The court before which such matter is in question may provide for the continued manufacture, use or sale of the thing made, purchased or used as specified, or for the manufacture, use or sale of which *substantial preparation was made before the grant of the reissue*, and it may also provide for the continued practice of any process patented by the reissue, practiced, or for the practice of which *substantial preparation was made, prior to the grant of the reissue*,

to the extent and under such terms as the court deems equitable for the *protection of investments made or business commenced before the grant of the reissue.*

This section provides that when certain conditions are present a reissue shall not abridge or affect certain rights of those who acted before the reissue was granted. Because of such pre-reissue activity, an infringer might enjoy a “personal intervening right” to continue what would otherwise be infringing activity after reissue. The underlying rationale for intervening rights is that the public has the right to use what is not specifically claimed in the original patent. Recapture through a reissue patent of what is dedicated to the public by omission in the original patent is permissible under specific conditions, but not at the expense of innocent parties. Therefore, one may be able to continue to infringe a reissue patent if the court decides that equity dictates such a result.

As we said in our first opinion, once the doctrine of intervening rights is properly raised, the court must consider whether to use its broad equity powers to fashion an appropriate remedy. We also held that the second sentence of the second paragraph in 35 U.S.C. § 252 was to be applied in this case in accordance with equity. Accordingly, the district court should have considered the relevant facts as applied to the portion of the statute which questions whether “substantial preparation was made by the infringer before the grant of the reissue.” Specifically, the district court’s inquiry should have been—and it is now our burden to decide—whether the post-reissue use of the 224 bundles which were made from pre-reissue spacer blocks constituted “substantial preparation” to merit the protection afforded by intervening rights, so as to protect “investments made . . . before the grant of reissue.” We stress that all those spacer blocks were on hand when the reissue patent issued.

Two sets of the district court’s factual findings weigh heavily in the present equitable determination of the application of intervening rights. First, in the district court’s initial findings in its first decision, it was established that, prior to the Re ’373 patent, Industrial and its patent attorney were fully aware of the ’617 patent. Second, the district court found that Industrial continued manufacturing after reissue on the advice of its patent counsel. This advice-of-counsel was given to Industrial in April 1980, while the ’617 patent was still extant, some 3 months before the Re ’373 patent issued (August 17, 1980), and over two months before Industrial’s patent counsel was even informed by Seattle Box’s patent counsel (July 9, 1980) of the reissue patent claims which had been allowed by the examiner. This pre-reissue advice, followed by Industrial, was to hold the concave block height to about 1/16 of an inch shorter than the pipe diameter. From these facts, it is apparent that Industrial was attempting to design its spacer blocks (including those it held on the date of the reissue patent) “around” the original ’617 patent claims which called for a spacer block with a height “*greater* than the diameter of the pipe.” It turned out that these blocks infringed the reissue patent (Re ’373), but they plainly did not literally

## DESIGNS

infringe the original '617 patent (and probably did *not* infringe that patent under the doctrine of equivalents).

To enable Seattle Box now to recapture (in the form of damages for post-reissue use of the 224 bundles made from pre-reissue spacer blocks) matter which Seattle Box had already dedicated to the public in the original patent, at the expense of Industrial which knew of the precise claims of that '617 patent, could open the door to a "gross injustice." In these circumstances, the new reissue claims in this case present a compelling case for the application of the doctrine of intervening rights because a person should be able to make business decisions secure in the knowledge that those actions which fall outside the original patent claims are protected. Here, the spacer blocks involved were made or acquired, before the reissue, so as not to infringe the then existing '617 patent.

Another fact which weighs heavily is that at the time of reissue Industrial had existing orders for 114 bundles. As we have noted, the remedy of intervening rights is calculated to protect an infringer's preexisting investments and business. Prior business commitments, such as previously placed orders and contracts, are one such example.

Another important factor courts have considered is whether non-infringing goods can be manufactured from the inventory used to manufacture the infringing product. The cost and ease of converting infringing items to non-infringing items is an important equitable consideration because the "infringer" can then avoid a total loss of his good faith investment. In this case, the district court did not make any finding of the cost of conversion or of possible non-infringing uses. In addition, Industrial has not asked for the continued use (without liability) of goods on hand at the time of ultimate judgment . . . . In fact, the part of the inventory at issue here had already been fully used before the district court issued its first opinion on May 4, 1982 passing on the issues of validity and infringement.

After weighing the facts and factors, we conclude that Industrial should clearly have been allowed to dispose of old inventory remaining on hand at the time of reissue, without liability to Seattle Box. The district court's conclusion to the contrary was an abuse of discretion.

## V

We reverse the district court's holding that intervening rights does not preclude damages as to the 224 bundles made from pre-reissue spacer blocks, and hold that the doctrine of intervening rights does bar such damages. . . .

NICHOLS, Senior Circuit Judge, concurring and dissenting.

Industrial had on hand on the reissue date orders for 114 bundles and inventory sufficient to make 224 bundles, with a total investment of \$30,539.36. As a source of § 252

## CHAPTER 12

equitable considerations, however, nothing in the inventory but the peculiar concave blocks were so processed as to be dedicated to this infringing use alone. They were worth 60 cents each, and being 12,100 in number, all were worth \$7,260. They have a powerful leverage indeed as they reduce the liability by approximately \$43,000, for the panel clears Industrial of infringement of all 224 bundles because of them.

As Industrial went right on infringing after filling 114 orders and using up the 12,100 blocks, and other items in its inventory on the reissue date, necessarily purchasing more as needed, it is apparent it never intended to exercise equitable intervening rights as such. It does not come into equity with clean hands. Its attitude was one of complete contempt for both the original patent and the reissue. In these circumstances, I do not think the district judge abused his discretion in not making any adjustment for the unfilled orders or the blocks or other inventory items. If he had done so, it would have been, I think, also within his discretion, but if he had given Industrial, as the panel does, a free pass for as many as 224 infringements, I would have thought that an abuse of his discretion. Our suggested possible options in the first opinion respecting application of § 252 were predicated . . . on Industrial's making a far more impressive show of its equities than it did in fact make. The statute, too, seems to me to visualize equities more impressive than unfilled orders and the mere existence in Industrial's inventory of so many 60 cent blocks, bought in face of the plainest warnings. . . .

### 2. Disclaimer

*Allen Archery, Inc. v. Browning Manufacturing Co.*  
819 F.2d 1087 (Fed. Cir. 1987)

FRIEDMAN, Circuit Judge.

This case involves claims 7, 8, 10, and 14 of U.S. Patent No. 3,486,495 for a bow, issued to H.W. Allen and owned by Allen Archery, Inc. The bow as depicted in the Allen patent is shown below:

## DESIGNS

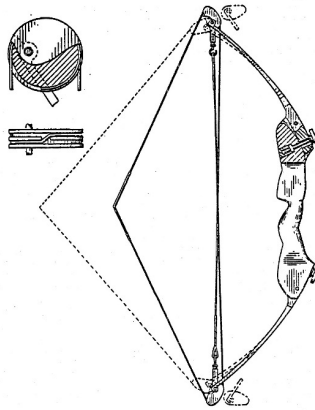

The district court described the invention the Allen patent covers as follows:

The Allen Patent relates to an archery bow known in the archery industry and to archers as a “compound bow.” The bow comprises a handle section and a pair of limbs secured to the handle section, a pair of eccentric pulley members being respectively mounted on the ends of the limbs. A bowstring is trained around the pulley members to present a central stretch and a pair of end stretches (three line lacing). The central stretch includes a nocking point for receiving the slotted tail or nock of an arrow. The pulley members may be either oval shaped or round, but in either case they are mounted off center. . . .

...

The Allen patent issued in December 1969. It contained 14 claims.

### B

Allen Archery filed complaints against the appellants/cross-appellees Browning, Browning Manufacturing, Bingham Projects, Elmont L. Bingham, and Joyce M. Bingham (referred to individually and collectively as Browning), in November 1977. Allen Archery filed two suits that charge patent infringement and, in the suit against Browning Manufacturing Company, breach of a patent licensing agreement. Browning countered with a suit seeking a declaratory judgment that the Allen patent was invalid and unenforceable and that Browning had not infringed it. The district court consolidated the three cases.

Prior to filing those complaints in the Utah District Court, Allen Archery in February 1976 had filed a suit in the United States District Court for the Central District of California charging Jennings Compound Bow, *et alia*, with infringing the Allen patent. With the agreement of the parties, the district court in the present case stayed proceedings until the *Jennings* case was decided.

## CHAPTER 12

In June 1974, prior to the initiation of the above suits, Allen Archery filed with the United States Patent and Trademark Office a voluntary disclaimer of claims 1, 2, and 11 of the Allen patent. After trial, the district court in the *Jennings* case held that claims 3 through 6, and 12 and 13 of the Allen patent were invalid as anticipated by, and obvious in view of, certain other patents. The court further held, however, that claims 7, 8, 10, and 14 of the Allen patent were valid and infringed. The Court of Appeals for the Ninth Circuit affirmed. Claim 9 apparently was not involved in *Jennings*, and it is not at issue here.

In June 1983, Allen Archery disclaimed the six claims that the California court had held invalid in *Jennings*.

### C

The present case then proceeded to trial before the Utah district court. . . .

. . .

In an opinion accompanied by detailed findings of fact and brief conclusions of law, the court held that . . . claims 7, 8, 10, and 14 of the Allen patent were valid and enforceable

. . . .

### III

Browning contends that the Allen patent is unenforceable ... [because] Allen Archery improperly failed to disclaim certain claims of the Allen patent before [the Patent and Trademark] Office . . . .

Browning contends that under *Maytag Co. v. Hurley Machine Co.*, 307 U.S. 243 (1939), Allen Archery's failure to disclaim claims 3 to 6, 12, and 13 at the same time it disclaimed claims 1, 2, and 11, made all the claims of the Allen patent unenforceable. The *Jennings* case in the Ninth Circuit rejected this contention on the ground that the *Maytag* rule did not survive the "repeal" in the 1952 Patent Act of the provisions of the earlier Patent Act upon which *Maytag* rested. The district court in the present case agreed with *Jennings*, and so do we.

In *Maytag*, the patentee had disclaimed claim 38 after a court of appeals had held it invalid. The Supreme Court held that because claim 39 was not "definitely distinguishable" from claim 38, "the patent is void for failure to disclaim claim 39 along with 38." The decision rested upon the Court's interpretation of sections 65 and 71 of title 35 as they then read.

Section 65, titled "Disclaimer," provided that if, "without any fraudulent or deceptive intention, a patentee has claimed more than that of which he was the original or first inventor or discoverer, his patent shall be valid for all that part which is truly and justly his own, and any such patentee may make disclaimer of such parts of the thing patented



as he shall not choose to claim.” Section 71 authorized a patentee whose claim was too broad under section 65 to sue for infringement of any portion of the patent “which was bona fide his own, if it is a material and substantial part of the thing patented, and definitely distinguishable from the parts claimed without right.” Section 71 continued:

But in every such case in which a judgment or decree shall be rendered for the plaintiff no costs shall be recovered unless the proper disclaimer has been entered at the Patent Office before the commencement of the suit. But no patentee shall be entitled to the benefits of this section if he has unreasonably neglected or delayed to enter a disclaimer.

In the 1952 revision of the patent statute, sections 65 and 71 were replaced by new sections 253 and 288, respectively:

§ 253. Disclaimer.

Whenever, without any deceptive intention, a claim of a patent is invalid, the remaining claims shall not thereby be rendered invalid. A patentee . . . may . . . make disclaimer of any complete claim . . . .

§ 288. Action for infringement of a patent containing an invalid claim.

Whenever, without deceptive intention, a claim of a patent is invalid, an action may be maintained for the infringement of a claim of the patent which may be valid. The patentee shall recover no costs unless a disclaimer of the invalid claim has been entered at the Patent Office before the commencement of the suit.

Those changes eliminated the provision in section 71 that a patentee could sue for infringement of claims definitely distinguishable from the invalid claims unless “he has unreasonably neglected or delayed to enter a disclaimer.” Under the new statute, disclaimer was required only before filing suit, and the sanction for failing thus to disclaim was not invalidity of the patent but merely the denial of costs.

Although in making these changes Congress did not specifically state that it intended to abrogate *Maytag*, that was the necessary effect of what Congress did. *Maytag* was expressly based on the statutory language that Congress deleted in 1952. Nevertheless, Browning argues that the “without deceptive intent” language in section 253 of the present law should be construed as continuing the patentee’s duty to disclaim. This argument fails, however, because the legislative history shows that Congress intended to eliminate the prior provision that failure to disclaim additional invalid claims made the remaining valid claims unenforceable. . . . The Senate Report on the bill stated:

This subject of disclaimers, in the present law, has resulted in a great deal of confusion and uncertainty in certain situations in the law which at times are almost

ridiculous. Consequently, the bill in two sections, 253 and 288, has introduced certain changes relating to disclaimers. . . .

[One of these] change[s] relates to the situation when a patent has two or more claims and one of them may be discovered to be invalid. There is now a provision in the statute under which an invalid claim must be disclaimed without unreasonable delay in order to save the rest of the patent. What delay is unreasonable is presently quite confusing, and the present law does not, as a matter of fact, prevent the patentee from suing again on the invalid claim if he so wishes.

The bill has eliminated that requirement. It has left the situation so that if one claim of a patent is invalid, the patentee may take it out. He may sue on the remaining claims which have whatever validity they may have on their own merits. That is, one bad claim does not affect the other claims, unless they are also bad for similar reasons.

Section 288 is the companion section to the disclaimer section, 253.

S. Rep. No. 1979, 82d Cong., 2d Sess., reprinted in 1952 U.S. Code Cong. & Admin. News 2394, 2401-03.

As the Ninth Circuit pointed out in *Jennings*, the “without deceptive intent” language in section 253 of the present law therefore cannot properly be construed as continuing the patentee’s duty to disclaim under the earlier provisions that the Supreme Court applied in *Maytag*. The Ninth Circuit there stated:

Viewed in the context of the legislative history described above, the statute appears not to require any duty to disclaim an invalid claim as a condition for patent enforcement of a valid claim. It is significant that the two former sections also contained language remarkably similar to the “deceptive intent” language, independent of the duty to disclaim provisions. In the former statutes, then, “deceptive intent” did not refer to intent in failing to disclaim. There is no reason to suppose that the 1952 express deletion of the duty to disclaim was intended to place a new construction on the remaining “deceptive intent” language. We are thus led to the conclusion that under present law a disclaimer is never a prerequisite for enforcement of valid patent claims.

686 F.2d at 783 (footnote omitted).

We therefore agree with and adopt the Ninth Circuit’s conclusions in *Jennings* that “the failure of a patentee to disclaim an invalid patent claim does not prevent the patentee from enforcing any remaining claims in the same patent which are otherwise valid.”

. . . The judgment of the district court is affirmed.

## 14. REMEDIES

Patent remedies can include the equitable remedy of injunctive relief and money damages to compensate for past infringement. Monetary awards can also, in certain cases, include attorney fees and enhancements beyond mere compensation. In design patent cases, a restitutionary remedy can lead to sizeable awards and complex legal questions.

### A. Injunctive Relief

The Patent Act provides that:

The several courts having jurisdiction of cases under this title may grant injunctions in accordance with the principles of equity to prevent the violation of any right secured by patent, on such terms as the court deems reasonable.

35 U.S.C. § 283. The topic of when patentees are entitled to injunctions became the subject of much debate (and litigation) in the years leading to—and immediately following—the case that follows.

#### *eBay v. MercExchange* 547 U.S. 388 (2006)

Justice Thomas delivered the opinion of the court.

Ordinarily, a federal court considering whether to award permanent injunctive relief to a prevailing plaintiff applies the four-factor test historically employed by courts of equity. Petitioners eBay Inc. and Half.com, Inc., argue that this traditional test applies to disputes arising under the Patent Act. We agree and, accordingly, vacate the judgment of the Court of Appeals.

#### I

Petitioner eBay operates a popular Internet Web site that allows private sellers to list goods they wish to sell, either through an auction or at a fixed price. Petitioner Half.com, now a wholly owned subsidiary of eBay, operates a similar Web site. Respondent MercExchange, L.L.C., holds a number of patents, including a business method patent for an electronic market designed to facilitate the sale of goods between private individuals by establishing a central authority to promote trust among participants. *See* U.S. Patent No. 5,845,265. MercExchange sought to license its patent to eBay and Half.com . . . but the

parties failed to reach an agreement. MercExchange subsequently filed a patent infringement suit against eBay and Half.com . . . . A jury found that MercExchange's patent was valid, that eBay and Half.com had infringed that patent, and that an award of damages was appropriate.

Following the jury verdict, the District Court denied MercExchange's motion for permanent injunctive relief. The Court of Appeals for the Federal Circuit reversed, applying its "general rule that courts will issue permanent injunctions against patent infringement absent exceptional circumstances." We granted certiorari to determine the appropriateness of this general rule.

## II

According to well-established principles of equity, a plaintiff seeking a permanent injunction must satisfy a four-factor test before a court may grant such relief. A plaintiff must demonstrate: (1) that it has suffered an irreparable injury; (2) that remedies available at law, such as monetary damages, are inadequate to compensate for that injury; (3) that, considering the balance of hardships between the plaintiff and defendant, a remedy in equity is warranted; and (4) that the public interest would not be disserved by a permanent injunction. The decision to grant or deny permanent injunctive relief is an act of equitable discretion by the district court, reviewable on appeal for abuse of discretion.

These familiar principles apply with equal force to disputes arising under the Patent Act. As this Court has long recognized, "a major departure from the long tradition of equity practice should not be lightly implied." Nothing in the Patent Act indicates that Congress intended such a departure. To the contrary, the Patent Act expressly provides that injunctions "may" issue "in accordance with the principles of equity."

To be sure, the Patent Act also declares that "patents shall have the attributes of personal property," § 261, including "the right to exclude others from making, using, offering for sale, or selling the invention," § 154(a)(1). According to the Court of Appeals, this statutory right to exclude alone justifies its general rule in favor of permanent injunctive relief. But the creation of a right is distinct from the provision of remedies for violations of that right. Indeed, the Patent Act itself indicates that patents shall have the attributes of personal property "subject to the provisions of this title," including, presumably, the provision that injunctive relief "may" issue only "in accordance with the principles of equity," § 283.

This approach is consistent with our treatment of injunctions under the Copyright Act. Like a patent owner, a copyright holder possesses "the right to exclude others from using his property." Like the Patent Act, the Copyright Act provides that courts "may" grant injunctive relief "on such terms as it may deem reasonable to prevent or restrain infringement of a copyright." 17 U.S.C. § 502(a). And as in our decision today, this Court

has consistently rejected invitations to replace traditional equitable considerations with a rule that an injunction automatically follows a determination that a copyright has been infringed.

. . . Although the District Court recited the traditional four-factor test, it appeared to adopt certain expansive principles suggesting that injunctive relief could not issue in a broad swath of cases. . . .

In reversing the District Court, the Court of Appeals . . . articulated a “general rule,” unique to patent disputes, “that a permanent injunction will issue once infringement and validity have been adjudged.” The court further indicated that injunctions should be denied only in the “unusual” case, under “exceptional circumstances” and “in rare instances to protect the public interest.” Just as the District Court erred in its categorical denial of injunctive relief, the Court of Appeals erred in its categorical grant of such relief.

Because we conclude that neither court below correctly applied the traditional four-factor framework that governs the award of injunctive relief, we vacate the judgment of the Court of Appeals, so that the District Court may apply that framework in the first instance. In doing so, we take no position on whether permanent injunctive relief should or should not issue in this particular case, or indeed in any number of other disputes arising under the Patent Act. We hold only that the decision whether to grant or deny injunctive relief rests within the equitable discretion of the district courts, and that such discretion must be exercised consistent with traditional principles of equity, in patent disputes no less than in other cases governed by such standards.

Accordingly, we vacate the judgment of the Court of Appeals and remand the case for further proceedings consistent with this opinion.

It is so ordered.

Chief Justice ROBERTS, with whom Justice SCALIA and Justice GINSBURG join, concurring.

I agree with the Court’s holding that “the decision whether to grant or deny injunctive relief rests within the equitable discretion of the district courts, and that such discretion must be exercised consistent with traditional principles of equity, in patent disputes no less than in other cases governed by such standards,” and I join the opinion of the Court. That opinion rightly rests on the proposition that “a major departure from the long tradition of equity practice should not be lightly implied.”

From at least the early 19th century, courts have granted injunctive relief upon a finding of infringement in the vast majority of patent cases. This “long tradition of equity practice” is not surprising, given the difficulty of protecting a right to exclude through monetary remedies that allow an infringer to use an invention against the patentee’s

wishes—a difficulty that often implicates the first two factors of the traditional four-factor test. This historical practice, as the Court holds, does not entitle a patentee to a permanent injunction or justify a general rule that such injunctions should issue. At the same time, there is a difference between exercising equitable discretion pursuant to the established four-factor test and writing on an entirely clean slate. “Discretion is not whim, and limiting discretion according to legal standards helps promote the basic principle of justice that like cases should be decided alike.” When it comes to discerning and applying those standards, in this area as others, “a page of history is worth a volume of logic.”

Justice KENNEDY, with whom Justice STEVENS, Justice SOUTER, and Justice BREYER join, concurring.

The Court is correct, in my view, to hold that courts should apply the well-established, four-factor test—without resort to categorical rules—in deciding whether to grant injunctive relief in patent cases. The Chief Justice is also correct that history may be instructive in applying this test. The traditional practice of issuing injunctions against patent infringers, however, does not seem to rest on “the difficulty of protecting a right to exclude through monetary remedies that allow an infringer to use an invention against the patentee’s wishes.” Both the terms of the Patent Act and the traditional view of injunctive relief accept that the existence of a right to exclude does not dictate the remedy for a violation of that right. To the extent earlier cases establish a pattern of granting an injunction against patent infringers almost as a matter of course, this pattern simply illustrates the result of the four-factor test in the contexts then prevalent. The lesson of the historical practice, therefore, is most helpful and instructive when the circumstances of a case bear substantial parallels to litigation the courts have confronted before.

In cases now arising trial courts should bear in mind that in many instances the nature of the patent being enforced and the economic function of the patent holder present considerations quite unlike earlier cases. An industry has developed in which firms use patents not as a basis for producing and selling goods but, instead, primarily for obtaining licensing fees. See *FTC, To Promote Innovation: The Proper Balance of Competition and Patent Law and Policy*, ch. 3, pp. 38–39 (Oct. 2003). For these firms, an injunction, and the potentially serious sanctions arising from its violation, can be employed as a bargaining tool to charge exorbitant fees to companies that seek to buy licenses to practice the patent. See *ibid.* When the patented invention is but a small component of the product the companies seek to produce and the threat of an injunction is employed simply for undue leverage in negotiations, legal damages may well be sufficient to compensate for the infringement and an injunction may not serve the public interest. In addition injunctive relief may have different consequences for the burgeoning number of patents over business methods, which were not of much economic and legal significance in earlier

## REMEDIES

times. The potential vagueness and suspect validity of some of these patents may affect the calculus under the four-factor test.

The equitable discretion over injunctions, granted by the Patent Act, is well suited to allow courts to adapt to the rapid technological and legal developments in the patent system. For these reasons it should be recognized that district courts must determine whether past practice fits the circumstances of the cases before them. With these observations, I join the opinion of the Court.

### Context & Application

1. Do you think that MercExchange wanted eBay to stop conducting online auctions? If not, why did MercExchange seek an injunction? Do you think most patent owners want to stop accused infringers? Does your answer depend on the business model of the patent holder? What does it tell us about patent law remedies if the answer is that many patent owners do not want an injunction?

2. Justice Kennedy's concurrence in *eBay* describes entities that "use patents not as a basis for producing and selling goods but, instead, primarily for obtaining licensing fees." These types of firms are sometimes referred to as "non-practicing entities" (NPEs) or "patent assertion entities" (PAEs). Some PAEs are pejoratively referred to as "trolls," based on their potential to extract settlements based on litigation costs rather than patent value. For a discussion that breaks down different business models that may all fit into the "troll" category and a call to address market distortions rather than "bad" actors, see Mark A. Lemley & A. Douglas Melamed, *Missing the Forest for the Trolls*, 113 COLUM. L. REV. 2117 (2013).

3. Following *eBay v. MercExchange*, courts have used the first two prongs of the test—irreparable injury and adequacy of money damages—to address the types of concerns raised in Justice Kennedy's concurrence. Courts have continued to issue injunctions when patent holders show that they are competitors who have lost market share as a result of infringement. For a suggestion that the public interest factor should play a greater role in determining whether an injunction is appropriate, see Sarah R. Wasserman Rajec, *Tailoring Remedies to Spur Innovation*, 61 AM. U. L. REV. 733, 751 (2012)

## B. Money Damages

### 1. Section 284

Section 284 damages are meant to provide compensatory relief. The statute provides:

Upon finding for the claimant the court shall award the claimant damages adequate to compensate for the infringement, but in no event less than a reasonable royalty for the use made of the invention by the infringer, together with interest and costs as fixed by the court.

35 U.S.C. § 284. Damages begin to accrue when there is notice or constructive notice of infringement. Constructive notice may be satisfied by marking a product with “patent” or “pat.” and the patent number. 35 U.S.C. § 287; *see Nike, Inc. v. Wal-Mart Stores, Inc.*, 138 F.3d 1437, 1446 (Fed. Cir. 1998) (holding that damages under 35 U.S.C. § 289, like § 284 damages, are subject to the marking requirement set forth in 35 U.S.C. § 287).

These compensatory damages usually take one of two forms: the patent holder’s lost profits attributable to the infringement or the amount of a reasonable royalty payment. When available, lost profits tend to be larger and therefore more desirable for patent holders who commercialize their own inventions. (Do you see why?) However, sometimes lost profits damages can be difficult to prove by a preponderance of the evidence, because they require a factfinder to determine what profit the patentee would have made in the absence of the defendant’s infringement. Proving this counterfactual is often difficult to do without inappropriate speculation. When lost profits damages are not available, reasonable royalties set a floor on monetary relief. Section 284 pointedly says courts “shall award” damages “in no event less than a reasonable royalty.” The courts must then grapple with the question of what royalty the parties would have agreed to, had they agreed—another difficult counterfactual for parties embroiled in litigation.

#### a. Lost Profits

*BIC Leisure Products, Inc. v. Windsurfing International, Inc.*  
1 F.3d 1214 (Fed. Cir. 1993)

RADER, Circuit Judge.

The United States District Court for the Southern District of New York awarded Windsurfing International, Inc. lost profits for BIC Leisure Products, Inc.’s infringement of U.S. Reissue Patent No. 31,167. . . . Assuming BIC had not been in the market,



## REMEDIES

Windsurfing did not show that BIC's customers would have purchased sailboards from Windsurfing and other manufacturers in proportion to their market shares. Therefore, this court reverses the award of lost profits based upon Windsurfing's market share. Otherwise, this court affirms.

### *Background*

BIC infringed Windsurfing's Reissue Patent No. 31,167, which covers sailboards. Windsurfing seeks damages from BIC for the period from March 8, 1983 (the reissue date of Windsurfing's patent) to September 30, 1985 (the date the district court enjoined BIC from further infringement).

Windsurfing primarily manufactured and marketed sailboards embodying its patented invention for the "One-Design Class." . . .

Windsurfing licensed its patented technology extensively. Windsurfing licensed at least twelve companies in Europe. At least one of the European licensees granted sublicenses to other European manufacturers. Windsurfing also granted licenses in the United States. Eventually, Windsurfing licensed twelve companies in the United States. With few exceptions, Windsurfing charged 7.5% of net sales for the U.S. licenses. All of the U.S. licensees, as well as some of the European licensees, competed against Windsurfing in the United States.

Windsurfing manufactured its boards using a rotomolding process. During the early 1980s, many of Windsurfing's competitors reduced their production costs with a new blowmolding process. Instead of switching to the more efficient blowmolding process, Windsurfing invested one million dollars in an unsuccessful attempt to improve its rotomolding process. Windsurfing controlled 29.2% of the sailboard market in 1983, 25.6% in 1984, and 13.6% in 1985.

BIC began selling sailboards in 1981. BIC manufactured with the more efficient blowmolding process. BIC did not sell sailboards with the One Design hull form. Rather, BIC's sailboards differed from Windsurfing's products. BIC instead sold boards at the lower end of the market's price spectrum, reflecting its decision to target the entry level segment of the sailboard market.

In comparison, Windsurfing priced its sailboards at the upper end of the sailboard price spectrum. During the years covered by the damages period, U.S. sailboard dealers charged the following average prices:

CHAPTER 14

<u>1983</u>		<u>1984</u>		<u>1985</u>	
Marker	837	Brockhaus	753	Mistral	804
Brockhaus	753	Mistral	741	Marker	774
Mistral	750	Marker	674	Brockhaus	750
Windsurfing	670	SAN/Romney	623	SAN	623
SAN/Romney	643	Windsurfing	589	Schutz	575
Alpha	574	Schutz	575	Windsurfing	571
Wayler	550	HiFly	527	HiFly	570
HiFly	518	Wayler	500	Wayler	500
SAN/Schaeffer	441	Alpha	450	O'Brien	477
O'Brien	436	O'Brien	412	Alpha	450
BIC	407	SAN/Schaeffer	388	AMF Inc.	380
AMF Inc.	377	AMF Inc.	384	BIC	312
Ten Cate	366	BIC	335	Ten Cate	253
AMF Mares	244	Ten Cate	299	AMF Mares	244
		AMF Mares	234		

The Patent and Trademark Office reissued Windsurfing's patent on March 8, 1983. On that date, BIC had 5,245 sailboards in its inventory and another 5,625 on order. BIC confirmed its purchase of the boards on order with a February 10, 1983 telex.

The district court applied the *Panduit* test to determine whether Windsurfing lost profits. The district court required Windsurfing to show (1) a demand for the patented product, (2) the absence of acceptable noninfringing substitutes, (3) its capacity to exploit the demand, and (4) the profits lost due to the infringement. The district court modified the *Panduit* test by presuming that Windsurfing would have captured a share of BIC's sales in proportion to Windsurfing's share of the sailboard market. Relying on *State Industries, Inc. v. Mor-Flo Industries, Inc.*, 883 F.2d 1573 (Fed. Cir. 1989), the district court awarded Windsurfing lost profits based upon its pro rata percentage of BIC's sales for each year of the damages period. In addition, the district court awarded Windsurfing lost royalties for the boards its licensees would have sold absent BIC's infringement. The court calculated the amount of lost royalties based upon a weighted average price of the boards sold by the licensees.

*Lost Profits*

Section 284 of title 35 provides:

Upon finding for the claimant the court shall award the claimant damages adequate to compensate for the infringement but in no event less than a reasonable royalty for the use made of the invention by the infringer.

The finding of the amount of damages for patent infringement is a question of fact on which the patent owner bears the burden of proof. Where the district court fixes the amount of damages, this court reviews that finding under the clearly erroneous standard of Federal Rule of Civil Procedure 52(a).

## REMEDIES

To recover lost profits as opposed to royalties, a patent owner must prove a causal relation between the infringement and its loss of profits. The patent owner must show that “but for” the infringement, it would have made the infringer’s sales. An award of lost profits may not be speculative. Rather the patent owner must show a reasonable probability that, absent the infringement, it would have made the infringer’s sales.

The district court clearly erred by failing to apply the “but for” test before awarding lost profits. The record in this case does not evince a reasonable probability that Windsurfing would have made its pro rata share of BIC’s sales had BIC not been in the market. During the period in question, at least fourteen competitors vied for sales in the sailboard market with prices ranging from \$234 to \$837. BIC’s boards sold for \$312 to \$407; Windsurfing’s boards sold for \$571 to \$670—a difference of over \$250 or about 60–80% above BIC’s selling range. Because Windsurfing concentrated on the One Design class hull form and BIC did not, Windsurfing’s boards differed fundamentally from BIC’s boards.

The record contains uncontradicted evidence that demand for sailboards is relatively elastic. The record further contains uncontradicted evidence that the sailboard market’s entry level, in which BIC competed, is particularly sensitive to price disparity. By purchasing BIC sailboards, BIC’s customers demonstrated a preference for sailboards priced around \$350, rather than One-Design boards priced around \$600. Therefore, without BIC in the market, BIC’s customers would have likely sought boards in the same price range.

Several manufacturers offered sailboards at prices much closer to BIC than to Windsurfing. At least two of Windsurfing’s licensees, O’Brien and HiFly, sold boards resembling BIC’s in the same distribution channels as BIC. On this record, Windsurfing did not show with reasonable probability that BIC’s customers would have purchased from Windsurfing in proportion with Windsurfing’s market share. The record shows rather that the vast majority of BIC’s customers would have purchased boards from O’Brien or HiFly if BIC’s boards had not been available. The district court erred in assuming that, without BIC in the market, its customers would have redistributed their purchases among all the remaining sailboards, including Windsurfing’s One Design boards at a price \$200 to \$300 more than BIC’s.

Moreover, Windsurfing’s sales continued to decline after the district court enjoined BIC’s infringement. This aspect of the record shows as well that Windsurfing did not capture its market share of the sales replacing BIC’s market sales. According to the record, the principal beneficiary of BIC’s exit appears to be O’Brien.

The district court applied the *Panduit* test for lost profits. Properly applied, the *Panduit* test is an acceptable, though not an exclusive, test for determining “but for” causation. The *Panduit* test, however, operates under an inherent assumption, not appropriate in this

case, that the patent owner and the infringer sell products sufficiently similar to compete against each other in the same market segment. If the patentee's and the infringer's products are not substitutes in a competitive market, Panduit's first two factors do not meet the "but for" test—a prerequisite for lost profits.

The first *Panduit* factor—demand for the patented product—presupposes that demand for the infringer's and patent owner's products is interchangeable. Under this assumption, evidence of sales of the infringing product may suffice to show Panduit's first factor, "demand for the patented product." *E.g., Gyromat Corp. v. Champion Spark Plug Co.*, 735 F.2d 549, 552 (Fed. Cir. 1984). This analysis assumes that the patent owner and the infringer sell substantially the same product. In *Gyromat*, for instance, the patent owner's and the infringer's products were similar in price and product characteristics. If the products are not sufficiently similar to compete in the same market for the same customers, the infringer's customers would not necessarily transfer their demand to the patent owner's product in the absence of the infringer's product. In such circumstances, as in this case, the first *Panduit* factor does not operate to satisfy the elemental "but for" test.

Similarly, the second *Panduit* factor—absence of acceptable, noninfringing alternatives—presupposes that the patentee and the infringer sell substantially similar products in the same market. To be acceptable to the infringer's customers in an elastic market, the alleged alternative "must not have a disparately higher price than or possess characteristics significantly different from the patented product." *Kaufman Co. v. Lantech, Inc.*, 926 F.2d 1136, 1142 (Fed. Cir. 1991) (citing *Gyromat*, 735 F.2d at 553). In *Kaufman*, for instance, the patent owner and the infringer sold substantially the same product. Thus Panduit's second factor, properly applied, ensures that any proffered alternative competes in the same market for the same customers as the infringer's product.

This court has held that a patent owner may satisfy the second *Panduit* element by substituting proof of its market share for proof of the absence of acceptable substitutes. This market share approach allows a patentee to recover lost profits, despite the presence of acceptable, noninfringing substitutes, because it nevertheless can prove with reasonable probability sales it would have made "but for" the infringement. Like *Panduit's* second prong, however, this market share test also assumes that the patent owner and the infringer compete in the same market. In *State Industries*, for instance, the patent owner, infringer, and the other manufacturers sold substantially similar products. This similarity of products is necessary in order for market share proof to show correctly satisfaction of *Panduit's* second factor.

The assumption underlying *Panduit*, *Gyromat*, and *State Industries* is not appropriate in this case. Instead, the record reveals that . . . the sailboard market was not a unitary market in which every competitor sold substantially the same product. Windsurfing and

## REMEDIES

BIC sold different types of sailboards at different prices to different customers. As noted, their sailboards differed significantly in terms of price, product characteristics, and marketing channels. On the facts of this case, Windsurfing did not show “but for” causation under a correct application of Panduit or otherwise. The district court erred in awarding lost profits.

Moreover, Windsurfing itself set the value of its patent rights by licensing its technology to nearly every company supplying sailboards in the United States without competing itself in most sailboard submarkets. Windsurfing valued its patent in terms of licensing royalties, not in terms of profits it could make by excluding others from the market. Without evidence to support Windsurfing’s claim to lost profits, this court reverses the district court’s award.

With regard to royalties, Windsurfing is entitled to receive lost royalties (on amounts Windsurfing’s licensees would have paid “but for” the infringement) and reasonable royalties (on amounts of any other BIC use, if any, of the patented invention). BIC challenges the methodology of the district court in calculating lost royalties per board, but this court concludes that the chosen methodology was within the court’s discretion. On remand, the trial court may award damages based upon the lost royalties per board calculation.

### *Price Erosion*

The district court evaluated the documentary and testimonial evidence on price erosion and found it too speculative to support an award of price erosion lost profits. This court finds nothing clearly erroneous in the district court’s finding.

The record shows that other market forces, not BIC, forced Windsurfing to lower its prices. The record is replete with evidence that funboards, wave boards, and other designs replaced One Design boards as the sailboard of choice for many practitioners. Besides reducing the demand for One Design boards, consumer choices also caused many companies to discount their stock of One Design boards to make room for the newer boards.

Furthermore, Windsurfing licensed many competitors who produced boards at less cost. The more efficient blowmolding process allowed Windsurfing’s competitors to cut prices. Windsurfing’s own licensing policies exacerbated this problem. When the European market peaked in the early 1980s, Windsurfing’s European licensees sold their excess inventory in the United States. The influx of European boards increased the supply of sailboards and further reduced prices. In light of these facts, the district court correctly found that Windsurfing failed to meet its burden of proof. Simply put, Windsurfing did not prove that it could have sold its boards at higher prices “but for” BIC’s infringement.

## Context & Application

1. What types of evidence does the court look to when calculating lost profits? Do any of these types of evidence strike you as more or less reliable?

2. In *BIC*, the court refers to the factors set forth in *Panduit Corp. v. Stahl Bros. Fibre Works*:

To obtain as damages the profits on sales he would have made absent the infringement, *i.e.*, the sales made by the infringer, a patent owner must prove: (1) demand for the patented product, (2) absence of acceptable noninfringing substitutes, (3) his manufacturing and marketing capability to exploit the demand, and (4) the amount of the profit he would have made.

575 F.2d 1152, 1156 (6th Cir. 1978). Must a party seeking an award of lost profits put forth evidence on all of these factors? Are all of these factors likely to be equally helpful or relevant in all cases?

## C. Reasonable Royalty

When lost profits are not available, courts use a reasonable royalty as a measure of compensatory damages for patent infringement.

*Lucent Technologies, Inc. v. Gateway, Inc.*  
580 F.3d 1301 (2009)

MICHEL, Chief Judge.

In December 1986, three computer engineers at AT&T filed a patent application, which eventually issued as U.S. Patent No. 4,763,356 (the “Day patent”), later assigned to Lucent. The patent “is generally directed to a method of entering information into fields on a computer screen without using a keyboard.” A user fills in the displayed fields by choosing concurrently displayed, predefined tools adapted to facilitate the inputting of the information in a particular field, wherein the predefined tools include an on-screen graphical keyboard, a menu, and a calculator. The system may display menus of information for filling in a particular field and may also be adapted to communicate with a host computer to obtain the information that is inserted into the fields. In addition, one of the displayed fields can be a bit-mapped graphics field, which the user fills in by writing on the touch screen using a stylus.

...

## REMEDIES

At trial, Lucent charged infringement by Microsoft of claims 19 and 21, among others, of the Day patent. Lucent alleged indirect infringement of claim 19 based on the sales and use of Microsoft Money, Microsoft Outlook, and Windows Mobile.

...

Figure 5 of the Day patent, shown below, illustrates an embodiment of the invention in which a graphical calculator overlays the form having multiple fields, one of which—“Quantity” (Qty 61)—is highlighted.

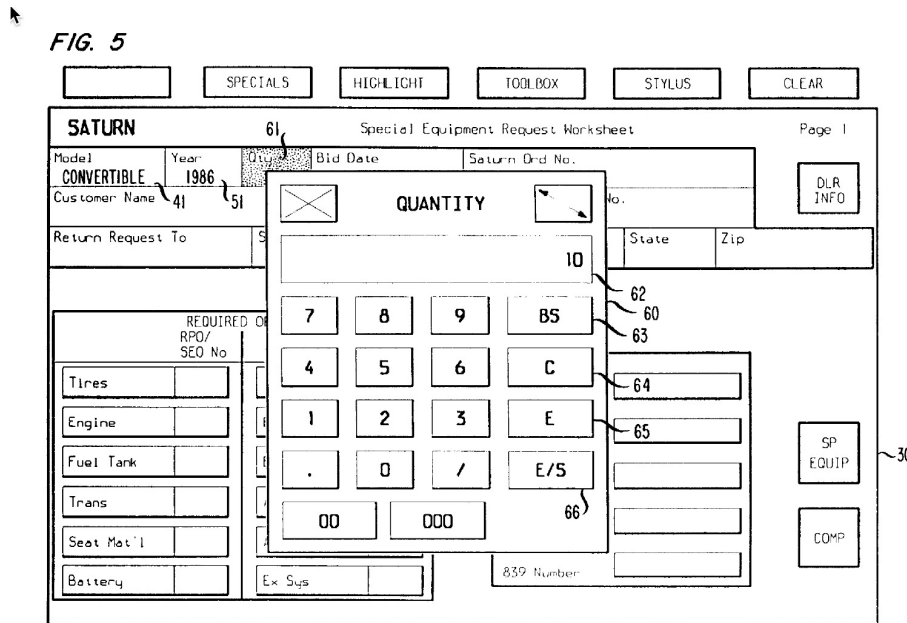

## IV

Based on the evidence of record, Microsoft (and Dell) sold approximately 110 million units of the three software products capable of practicing the methods of the asserted claims. The total dollar value of the sales was approximately \$8 billion. At trial, Lucent's theory of damages was based on 8% of sales revenue for the accused software products, and it asked the jury to award \$561.9 million based on Microsoft's infringing sales. Microsoft countered that a lump-sum payment of \$6.5 million would have been the correct amount for licensing the protected technology.

Microsoft challenges the jury's damages award on several bases. First, Microsoft argues that the jury should not have applied the entire market value rule to the value of its three software products. Microsoft's second argument for reversing the damages award is that, for method claims, *Dynacore Holdings Corp. v. U.S. Philips Corp.*, 363 F.3d 1263 (Fed. Cir. 2004), requires that damages be limited to the proven number of instances

of actual infringing use. Microsoft states that, “under *Dynacore*, Lucent had to tie its damages claim to demonstrated instances of direct infringement.” For the reasons stated below, we reject both arguments as presented by Microsoft. We agree, nevertheless, with Microsoft’s argument that substantial evidence does not support the jury’s verdict of a lump-sum royalty payment of \$357,693,056.18. Further, to the extent the jury relied on an entire market value calculation to arrive at the lump-sum damages amount, that award is not supported by substantial evidence and is against the clear weight of the evidence.

#### *Reasonable Royalty*

“Upon finding for the claimant the court shall award the claimant damages adequate to compensate for the infringement, but in no event less than a reasonable royalty for the use made of the invention by the infringer, together with interest and costs as fixed by the court.” 35 U.S.C. § 284. As the Supreme Court has framed the general issue of determining damages, at least for competitors, a court must ask, “Had the Infringer not infringed, what would the Patent Holder have made?” In the Supreme Court’s words, awarding damages through litigation attempts to assess “the difference between the patentee’s pecuniary condition after the infringement, and what his condition would have been if the infringement had not occurred.” *Yale Lock Mfg. Co. v. Sargent*, 117 U.S. 536, 552 (1886).

...

Litigants routinely adopt several approaches for calculating a reasonable royalty. The first, the analytical method, focuses on the infringer’s projections of profit for the infringing product. The second, more common approach, called the hypothetical negotiation or the “willing licensor-willing licensee” approach, attempts to ascertain the royalty upon which the parties would have agreed had they successfully negotiated an agreement just before infringement began. See *Georgia-Pacific Corp. v. U.S. Plywood Corp.*, 318 F. Supp. 1116, 1120 (S.D.N.Y.1970). The hypothetical negotiation tries, as best as possible, to recreate the *ex ante* licensing negotiation scenario and to describe the resulting agreement. In other words, if infringement had not occurred, willing parties would have executed a license agreement specifying a certain royalty payment scheme. The hypothetical negotiation also assumes that the asserted patent claims are valid and infringed.

In the present appeal, the parties, in offering the damages evidence, each adopted the hypothetical negotiation approach, without objection. We review the damages award within the *Georgia-Pacific* framework.

Before the district court, Lucent asked for a damages award based only on a running royalty. Microsoft, on the other hand, told the jury that the damages should be a lump-sum royalty payment of \$6.5 million. Based on the verdict form, the jury decided on a lump-sum award, not a running royalty. The verdict form notes a lump-sum damages



## REMEDIES

amount and no amount (i.e., zero or “N/A”) on the lines for a running royalty. Faced with the jury's selection, our task is to determine whether substantial evidence supports a lump-sum, paid-in-full royalty of approximately \$358 million for Microsoft's indirect infringement of the Day patent. To do this, we must decide whether substantial evidence supports the jury's implicit finding that Microsoft would have agreed to, at the time of the hypothetical negotiation, a lump-sum, paid-in-full royalty of about \$358 million. In performing this analysis, we focus mainly on the damages case as it applies to Microsoft Outlook, as infringement by the use of Outlook apparently constituted the vast majority of the award. We focus also on the relevant *Georgia-Pacific* factors, as presented to the jury through all the evidence and particularly the experts' testimony.

### *Factor 2*

The second *Georgia-Pacific* factor is “the rates paid by the licensee for the use of other patents comparable to the patent in suit.” This factor examines whether the licenses relied on by the patentee in proving damages are sufficiently comparable to the hypothetical license at issue in suit. Subsumed within this factor is the question of whether the licensor and licensee would have agreed to a lump-sum payment or instead to a running royalty based on ongoing sales or usage.

Significant differences exist between a running royalty license and a lump-sum license. In a standard running royalty license, the amount of money payable by the licensee to the patentee is tied directly to how often the licensed invention is later used or incorporated into products by the licensee. A running royalty structure shifts many licensing risks to the licensor because he does not receive a guaranteed payment. Royalties are dependent on the level of sales or usage by the licensee, which the licensee can often control.

Compared to a running royalty analysis, a lump-sum analysis involves different considerations. A lump-sum license “benefits the patentholder in that it enables the company to raise a substantial amount of cash quickly and benefits the target [i.e., the licensee] by capping its liability and giving it the ability, usually for the remainder of the patent term, to actually use the patented technology in its own products without any further expenditure.” RICHARD F. CAULEY, *WINNING THE PATENT DAMAGES CASE* 47 (2009). The lump-sum license removes or shifts certain risks inherent in most arms-length agreements. A lump-sum license removes any risk that the licensee using the patented invention will underreport, e.g., engage in false reporting, and therefore underpay, as can occur with a running royalty agreement. Additionally, for both contracting parties, the lump-sum license generally avoids ongoing administrative burdens of monitoring usage of the invention.

A further, important consideration is that an upfront, paid-in-full royalty removes, as an option for the licensee, the ability to reevaluate the usefulness, and thus the value, of the patented technology as it is used and/or sold by the licensee. As generally employed, once a lump-sum license is duly executed, the licensee is obligated to pay the entire, agreed-upon amount for the licensed technology, regardless of whether the technology is commercially successful or even used. A licensee to a lump-sum agreement, under usual licensing terms, cannot later ask for a refund from the licensor based on a subsequent decision not to use the patented technology. There is no provision for buyer's remorse.

The lump-sum structure also creates risks for both parties. The licensed technology may be wildly successful, and the licensee may have acquired the technology for far less than what later proved to be its economic value. The alternative risk, of course, is the licensee may have paid a lump-sum far in excess of what the patented invention is later shown to be worth in the marketplace.

As noted, Lucent's licensing expert, Roger Smith, argued for damages based solely on a running royalty rate. Smith emphasized his choice of a running royalty over a lump-sum payment.

Q: Now, in each case, in the other patents in suit and then finally the Day 356 form entry patent, in each case you've selected a running royalty structure for your reasonable royalty; is that right?

A: I certainly did, yes.

He also explained that "the running royalty in a hypothetical negotiation such as the one we're considering here would be appropriate, even though lump-sum does have the advantage that brings the money up front or at least some of it."

On appeal, however, Lucent defends the damages award, contending that substantial evidence supports the lump-sum award of about \$358 million. This is problematic for several reasons. First, no evidence of record establishes the parties' expectations about how often the patented method would be used by consumers. Second, the jury heard little factual testimony explaining how a license agreement structured as a running royalty agreement is probative of a lump-sum payment to which the parties would have agreed. Third, the license agreements for other groups of patents, invoked by Lucent, were created from events far different from a license negotiation to avoid infringement of the one patent here, the Day patent.

Parties agreeing to a lump-sum royalty agreement may, during the license negotiation, consider the expected or estimated usage (or, for devices, production) of a given invention, assuming proof is presented to support the expectation, because the more frequently most inventions are used, the more valuable they generally are and therefore

## REMEDIES

the larger the lump-sum payment. Conversely, a minimally used feature, with all else being equal, will usually command a lower lump-sum payment. In this case, Lucent identifies no documentary evidence or testimony showing the parties' expectations as to usage of the claimed method. Lucent submitted no evidence upon which a jury could reasonably conclude that Microsoft and Lucent would have estimated, at the time of the negotiation, that the patented date-picker feature would have been so frequently used or valued as to command a lump-sum payment that amounts to approximately 8% of the sale price of Outlook.

Lucent's expert Mr. Smith did try to explain how one would calculate what an acceptable lump-sum would be.

Q: Well, when one is considering what the magnitude of a lump-sum payment might be, does one ever look at what the expected royalty—total royalty would be produced by a running royalty based on the available information at that time?

A: That generally is the way a lump sum would be determined, by looking at what the running royalty—what the value of each use of the patent might be and then speculating as to the extent of the future use.

But an explanation urging jurors to rely on speculation, without more, is often insufficient. In short, Smith's testimony could be interpreted as suggesting to the jury that it was proper to "speculate" as to the proper lump-sum damages amount even though he may have intended the word "speculate" to mean "estimate."

Despite this shortcoming in its evidence, Lucent relies on eight varied license agreements which purportedly support the jury's lump-sum damages award. When we examine these license agreements, along with the relevant testimony, we are left with two strong conclusions. First, some of the license agreements are radically different from the hypothetical agreement under consideration for the Day patent. Second, with the other agreements, we are simply unable to ascertain from the evidence presented the subject matter of the agreements, and we therefore cannot understand how the jury could have adequately evaluated the probative value of those agreements.

Only four of the eight agreements purport to be lump-sum agreements: (1) a 1993 agreement between Dell and IBM for \$290 million; (2) a 1996 agreement between Microsoft and Hewlett-Packard for \$80 million; (3) a 1997 agreement between Microsoft and Apple Computer for \$93 million; and (4) a 1999 agreement between Microsoft and Inprise for \$100 million. ...

...

Lucent had the burden to prove that the licenses were sufficiently comparable to support the lump-sum damages award. The law does not require an expert to convey all

his knowledge to the jury about each license agreement in evidence, but a lump-sum damages award cannot stand solely on evidence which amounts to little more than a recitation of royalty numbers, one of which is arguably in the ballpark of the jury's award, particularly when it is doubtful that the technology of those license agreements is in any way similar to the technology being litigated here.

Lucent also cites four running-royalty license agreements which purportedly provide substantial evidence supporting a lump-sum damages award of approximately \$358 million. A significant shortcoming of these agreements is their "running-royalty" nature, however. . . . For a jury to use a running-royalty agreement as a basis to award lump-sum damages, however, some basis for comparison must exist in the evidence presented to the jury. In the present case, the jury had almost no testimony with which to recalculate in a meaningful way the value of any of the running royalty agreements to arrive at the lump-sum damages award.

Additionally, in its brief before us, Lucent appears to misunderstand the nature of a per-unit royalty. Lucent appears to consider a per-unit royalty as being equivalent to a lump-sum royalty. What that statement ignores is the relationship between product revenues and per-unit running royalties. A per-unit running royalty is paid based on the number of units ultimately sold (or made, etc.), which is of course directly related to product revenues. As more units are sold, more revenue is earned and more royalties are paid. If the licensee chooses to omit the patented feature from its commercial product, the licensee will generally owe no per-unit royalty. Thus, a per-unit running royalty agreement differs from a lump-sum agreement in the same general ways a percentage-of-price running royalty agreement differs from a lump-sum agreement.

Furthermore, the running royalty agreements put into evidence, as with the lump-sum agreements, differ substantially from the hypothetical negotiation scenario involving the Day patent. The four running royalty agreements upon which Lucent relies are agreements between itself and Vox Communications ("Vox agreement"); between itself and Kenwood ("Kenwood agreement"); between itself and Acer ("Acer agreement"); and between Microsoft and MPEG-LA ("MPEG agreement").

The Vox agreement covered five Lucent patents, which, as explained by Lucent's expert, are directed to PC graphics boards manufactured by Vox. In addition to a lump-sum payment of \$50,000, Vox agreed to pay a per-unit rate of \$2.00 for each licensed product. But no testimony described how the patented technology of the Vox agreement relates to the licensed graphics boards. Lucent's expert never explained to the jury whether the patented technology is essential to the licensed product being sold, or whether the patented invention is only a small component or feature of the licensed product (as is the case here). The jury also had no information about the price of Vox's PC graphics boards and thus was unable to assess the magnitude of the \$2.00 rate, which

## REMEDIES

seems particularly relevant given Lucent's defense of an award amounting to about 8% of the market value of Outlook. In the absence of the price of graphics boards, the \$2.00 value is difficult, if not impossible, to evaluate. The testimony of Lucent's expert relating to the Vox agreement was confined essentially to the fact that the agreement is a cross-licensing agreement in which the rights granted to Lucent were royalty-free and that the royalty rate is structured as a commuted rate.

The Kenwood agreement, covering two Lucent patents directed to DVD player products, is a hybrid lump-sum/running royalty cross-license agreement. Kenwood agreed to pay Lucent an up-front payment of \$3 million along with a per-unit royalty of \$1.50 for each product in excess of 300,000 units. Lucent's expert told the jury that the Kenwood agreement was a cross-license, conveying rights to Lucent to practice Kenwood's patents, but the jury never learned anything about those patent rights and how valuable or essential those rights were. Even if we were to apply the \$1.50 per unit rate of the Kenwood agreement to the number of infringing units that could be used to infringe in the present case, this would yield only about \$165 million, substantially less than the \$358 million awarded by the jury.

The Acer agreement, executed in 1998, involved eight patents and various commercial products. Lucent refers to the Acer agreement as one involving PC-related patents. During his testimony, Lucent's expert focused almost exclusively on the per-unit royalty rate of \$2.50 and the lump-sum payment of \$14.5 million. But the jury again did not hear any explanation of the types of products covered by the agreement or the various royalty rates set forth in the agreement. Specifically, the agreement calls for different royalties for different products. For so-called "reportable products," the rate is not a fixed dollar amount but set at 2%, while the royalty rates for "semiconductive devices" is in the range of 1%. Furthermore, Lucent did not explain how the fact that the Acer agreement involved eight patents affects how probative it is of the Microsoft-Lucent hypothetical negotiation over one patent. Nor is there any document or testimony upon which a jury could have considered how similar or dissimilar the patented technology of the Acer agreement is to the invention of using the date-picker. Nor is there any evidence or testimony about how the \$2.50 per unit rate corresponds to a percentage of the cost of the "personal computers" sold under the license agreement. It is not implausible that the average price of the computers subject to the Acer agreement was close to \$1000. Such an average price would mean the \$2.50 per-unit rate of the Acer agreement equates to approximately one-quarter of one percent of the value of the computer, which is about one-thirtieth the constructive rate awarded to Lucent.

Finally, the MPEG agreement on its face supports a higher royalty rate of \$4 per unit. But, as with the other running royalty agreements, the structure of the MPEG agreement is more complicated, and the jury had little to no testimony explaining how such

complexity would have affected the hypothetical negotiation analysis. Specifically, the 31–page agreement contains numerous provisions covering various MPEG-related products (e.g., decoding products, distribution encoding products, program stream products, etc.). Moreover, the various products appear to have different royalty rates, some as low as a penny per unit.

We now consider what Microsoft advocated, namely that the hypothetical negotiation would have yielded a lump-sum licensing agreement for \$6.5 million. For whatever reason, Microsoft urged the jury to accept its theory based on a proffer of a single license Microsoft had executed for a graphical user interface technology. Thus, at a minimum, a reasonable jury could have awarded \$6.5 million, or some larger amount as permitted by the evidence.

But we see little evidentiary basis under *Georgia–Pacific* Factor 2 for awarding roughly three to four times the average amount in the lump-sum agreements in evidence. Here the award was \$358 million; there, the amounts were \$80, 93, 100, and 290 million. That some licenses were cross-licenses or commuted-rate licenses—which may warrant a higher damages award—does not fill the evidentiary lacunae. Again, it was Lucent’s burden to prove that the licenses relied on were sufficiently comparable to sustain a lump-sum damages award of \$358 million. This is not an instance in which the jury chose a damages award somewhere between maximum and minimum lump-sum amounts advocated by the opposing parties. For the reasons stated, Factor 2 weighs strongly against the jury’s award.

#### *Factors 10 and 13*

Factor 10 is “the nature of the patented invention; the character of the commercial embodiment of it as owned and produced by the licensor; and the benefits to those who have used the invention.” *Georgia–Pacific*, 318 F. Supp. at 1120. Factor 13 is “the portion of the realizable profit that should be credited to the invention as distinguished from non-patented elements, the manufacturing process, business risks, or significant features or improvements added by the infringer.” These two factors, at least as applied to the facts of this case, both aim to elucidate how the parties would have valued the patented feature during the hypothetical negotiation.

The evidence can support only a finding that the infringing feature contained in Microsoft Outlook is but a tiny feature of one part of a much larger software program. Microsoft’s expert explained that Outlook’s e-mail component is “the part of Outlook that’s most commonly used by our customers.” Microsoft’s witness also explained that, in addition to sending and receiving e-mails, a user can create electronic tasks and notes. Additionally, Outlook can be used as an electronic Rolodex™, storing contact information, such as phone numbers, addresses, and the like. It also has a fully functional

calendar system, in which a user can record appointments, meetings, and other items on one's schedule. As Lucent's own expert testified, Outlook is a "personal organizer" that is "an integrated suite of abilities to do e-mail, to set up contacts, to arrange meetings, to maintain your personal calendar, et cetera." In short, Outlook is an enormously complex software program comprising hundreds, if not thousands or even more, features. We find it inconceivable to conclude, based on the present record, that the use of one small feature, the date-picker, constitutes a substantial portion of the value of Outlook.

The parties presented little evidence relating to Factor 13. Nonetheless, the only reasonable conclusion is that most of the realizable profit must be credited to non-patented elements, such as "the manufacturing process, business risks, or significant features or improvements added by Microsoft." As explained by Microsoft's expert Mr. Kennedy, Outlook consists of millions of lines of code, only a tiny fraction of which encodes the date-picker feature. Although the weighing of Factor 13 cannot be reduced to a mere counting of lines of code, the glaring imbalance between infringing and non-infringing features must impact the analysis of how much profit can properly be attributed to the use of the date-picker compared to non-patented elements and other features of Outlook. Here, numerous features other than the date-picker appear to account for the overwhelming majority of the consumer demand and therefore significant profit.

The only reasonable conclusion that can be drawn from this evidence is that the infringing use of Outlook's date-picker feature is a minor aspect of a much larger software program and that the portion of the profit that can be credited to the infringing use of the date-picker tool is exceedingly small. For these reasons, Factors 10 and 13 of *Georgia-Pacific* provide little support for the jury's lump-sum damages award of \$357,693,056.18.

#### *Factor 11*

Factor 11 is "the extent to which the infringer has made use of the invention; and any evidence probative of the value of that use." *Georgia-Pacific*, 318 F. Supp. at 1120. As with Factors 10 and 13, the eleventh factor informs the court and jury about how the parties would have valued the patented feature during the hypothetical negotiation. In doing so, Factor 11 relies on evidence about how much the patented invention has been used. Implicit in this factor is the premise that an invention used frequently is generally more valuable than a comparable invention used infrequently.

...

Consideration of evidence of usage after infringement started can, under appropriate circumstances, be helpful to the jury and the court in assessing whether a royalty is reasonable. Usage (or similar) data may provide information that the parties would frequently have estimated during the negotiation. . . . Such data might, depending on the case, come from sales projections based on past sales, consumer surveys, focus group

testing, and other sources. Even though parties to a license negotiation will usually not have precise data about future usage, they often have rough estimates as to the expected frequency of use. This quantitative information, assuming it meets admissibility requirements, ought to be given its proper weight, as determined by the circumstances of each case.

On the other hand, we have never laid down any rigid requirement that damages in all circumstances be limited to specific instances of infringement proven with direct evidence. Such a strict requirement could create a hypothetical negotiation far-removed from what parties regularly do during real-world licensing negotiations. As shown by the evidence in this case, companies in the high-tech computer industry often strike licensing deals in which the amount paid for a particular technology is not necessarily limited to the number of times a patented feature is used by a consumer. A company licensing a patented method often has strong reasons not to tie the royalty amount strictly to usage. The administrative cost of monitoring usage can be prohibitively expensive. . . . Thus, potential licensors and licensees routinely agree to royalty payments regardless of whether the invention is used frequently or infrequently by the consumer.

With the foregoing in mind, we observe that the evidence of record is conspicuously devoid of any data about how often consumers use the patented date-picker invention.

. . . As we noted above, substantial evidence supports the jury's verdict of indirect infringement by Microsoft. But all the circumstantial evidence supports is the jury's implicit finding that at least one person performed the patented method one time in the United States sometime during the relevant period. Beyond that finding, all the jury had was speculation. No evidence describes how many Microsoft Outlook users had ever performed the patented method or how many times. Lucent had the burden to prove that the extent to which the infringing method has been used supports the lump-sum damages award.

#### *Other Factors*

Other *Georgia-Pacific* factors applicable here include "the nature and scope of the license, as exclusive or nonexclusive" (Factor 3); "the licensor's established policy and marketing program to maintain his patent monopoly" (Factor 4); "the commercial relationship between the licensor and the licensee" (Factor 5); "the established profitability of the product made under the patent" (Factor 8); "the utility and advantages of the patent property over the old modes or devices" (Factor 9); and "the portion of the profit or of the selling price that may be customary to allow for the use of the invention" (Factor 12). To the extent these factors are relevant, they appear somewhat to offset one another.



## REMEDIES

For instance, Factor 8, the profitability of the product made, supports a higher versus a lower reasonable royalty, given the unrebutted evidence that the products at issue are sold with an approximately 70–80% profit margin. Contrasting this evidence are Factors 3 and 9. Non-exclusive licenses generally command lower royalties. And, from the evidence presented, the infringing use of the date-picker seems to have, at best, only a slight advantage over what is arguably the closest prior art. We are mindful, however, that a jury could have reasonably concluded otherwise with several of the factors mentioned here. Even so, such reasonable conclusions, in this case, cannot overcome the substantial infirmities in the evidence for the other factors detailed above.

### *Conclusion on Lump-Sum Reasonable Royalty*

Having examined the relevant *Georgia-Pacific* factors, we are left with the unmistakable conclusion that the jury's damages award is not supported by substantial evidence, but is based mainly on speculation or guesswork. When the evidence is viewed in toto, the jury's award of a lump-sum payment of about \$358 million does not rest on substantial evidence and is likewise against the clear weight of the evidence. The evidence does not sustain a finding that, at the time of infringement, Microsoft and Lucent would have agreed to a lump-sum royalty payment subsequently amounting to approximately 8% of Microsoft's revenues for the sale of Outlook (and necessarily a larger percentage of Outlook's profits). We need not identify any particular *Georgia-Pacific* factor as being dispositive. Rather, the flexible analysis of all applicable *Georgia-Pacific* factors provides a useful and legally-required framework for assessing the damages award in this case. Furthermore, we do not conclude that the aforementioned license agreements (or other evidence) cannot, as a matter of law, support the damages award in this case. Instead, the evidence as presented did not reach the "substantial evidence" threshold and therefore no reasonable jury could have found that Lucent carried its burden of proving that the evidence, under the relevant *Georgia-Pacific* factors, supported a lump-sum damages award of \$357,693,056.18.

...

Creating a licensing agreement for patented technology is, at best, an inexact science. In actual licensing negotiations, willing parties negotiating at arms-length do not necessarily generate and analyze precise economic data concerning the perceived value of a patented invention. A complicated case this was, and the damages evidence of record was neither very powerful, nor presented very well by either party. Most jury damages awards reviewed on appeal have been held to be supported by substantial evidence. Nonetheless, on post-trial JMOL motions, district court judges must scrutinize the evidence carefully to ensure that the "substantial evidence" standard is satisfied, while keeping in mind that a reasonable royalty analysis "necessarily involves an element of approximation and uncertainty."

*Entire Market Value Analysis*

Microsoft argues that the damages award must be reversed because the jury erroneously applied the entire market value rule. Despite the jury's indication on the verdict form that it was awarding a lump-sum reasonable royalty, Microsoft believes that the only way the jury could have calculated a figure of \$357,693,056.18 was by applying a royalty percentage to a total sales figure of the infringing software products. Indeed, it is difficult to understand how the jury could have chosen its lump-sum figure down to the penny unless it used a running royalty calculation. Furthermore, as Microsoft explains in its brief, working the math backwards strongly suggests that the jury must have used some calculation of a rate applied to the entire market value of the software. . . . Assuming that the jury did apply the entire market value rule, such application would amount to legal error for two reasons.

In one sense, our law on the entire market value rule is quite clear. For the entire market value rule to apply, the patentee must prove that "the patent-related feature is the basis for customer demand."

...

The first flaw with any application of the entire market value rule in the present case is the lack of evidence demonstrating the patented method of the Day patent as the basis—or even a substantial basis—of the consumer demand for Outlook. . . . [T]he infringing use of the date-picker tool in Outlook is but a very small component of a much larger software program. The vast majority of the features, when used, do not infringe. The date-picker tool's minor role in the overall program is further confirmed when one considers the relative importance of certain other features, e.g., e-mail. Consistent with this description of Outlook, Lucent did not carry its evidentiary burden of proving that anyone purchased Outlook because of the patented method. . . . And when we consider the importance of the many features not covered by the Day patent compared to the one infringing feature in Outlook, we can only arrive at the unmistakable conclusion that the invention described in claim 19 of the Day patent is not the reason consumers purchase Outlook. Thus, Lucent did not satisfy its burden of proving the applicability of the entire market value rule.

. . . Because the damages award based on the infringing date-picker feature of Outlook is not supported by substantial evidence and is contrary to the clear weight of the evidence, the damages award must be vacated. . . .

...

Furthermore, Lucent's expert admitted that there was no evidence that Microsoft had ever agreed to pay an 8% royalty on an analogous patent.

## REMEDIES

Although our law states certain mandatory conditions for applying the entire market value rule, courts must nevertheless be cognizant of a fundamental relationship between the entire market value rule and the calculation of a running royalty damages award. Simply put, the base used in a running royalty calculation can always be the value of the entire commercial embodiment, as long as the magnitude of the rate is within an acceptable range (as determined by the evidence). Indeed, “all running royalties have at least two variables: the royalty base and the royalty rate.” Microsoft surely would have little reason to complain about the supposed application of the entire market value rule had the jury applied a royalty rate of 0.1% (instead of 8%) to the market price of the infringing programs. Such a rate would have likely yielded a damages award of less than Microsoft’s proposed \$6.5 million. Thus, even when the patented invention is a small component of a much larger commercial product, awarding a reasonable royalty based on either sale price or number of units sold can be economically justified.

...

... The evidence of record in the present dispute illustrates the importance the entire market value may have in reasonable royalty cases. The license agreements admitted into evidence (without objection from Microsoft, we note) highlight how sophisticated parties routinely enter into license agreements that base the value of the patented inventions as a percentage of the commercial products’ sales price. There is nothing inherently wrong with using the market value of the entire product, especially when there is no established market value for the infringing component or feature, so long as the multiplier accounts for the proportion of the base represented by the infringing component or feature.

### *Conclusion*

For the foregoing reasons, we affirm the district court’s denial of Microsoft’s JMOL motion for non-infringement. We reverse the district court’s denial of Microsoft’s JMOL regarding the damages award, vacate the award, and remand for a new trial on damages.

### Context & Application

1. In *Lucent*, the court refers to the “*Georgia-Pacific* factors.” In *Georgia-Pacific*, the district court said:

A comprehensive list of evidentiary facts relevant . . . to the determination of the amount of a reasonable royalty for a patent license may be drawn from a conspectus of the leading cases. The following are some of the factors *mutatis mutandis* seemingly more pertinent to the issue herein:

1. The royalties received by the patentee for the licensing of the patent in suit, proving or tending to prove an established royalty.

## CHAPTER 14

2. The rates paid by the licensee for the use of other patents comparable to the patent in suit.
3. The nature and scope of the license, as exclusive or non-exclusive; or as restricted or non-restricted in terms of territory or with respect to whom the manufactured product may be sold.
4. The licensor's established policy and marketing program to maintain his patent monopoly by not licensing others to use the invention or by granting licenses under special conditions designed to preserve that monopoly.
5. The commercial relationship between the licensor and licensee, such as, whether they are competitors in the same territory in the same line of business; or whether they are inventor and promoter.
6. The effect of selling the patented specialty in promoting sales of other products of the licensee; that existing value of the invention to the licensor as a generator of sales of his non-patented items; and the extent of such derivative or convoyed sales.
7. The duration of the patent and the term of the license.
8. The established profitability of the product made under the patent; its commercial success; and its current popularity.
9. The utility and advantages of the patent property over the old modes or devices, if any, that had been used for working out similar results.
10. The nature of the patented invention; the character of the commercial embodiment of it as owned and produced by the licensor; and the benefits to those who have used the invention.
11. The extent to which the infringer has made use of the invention; and any evidence probative of the value of that use.
12. The portion of the profit or of the selling price that may be customary in the particular business or in comparable businesses to allow for the use of the invention or analogous inventions.
13. The portion of the realizable profit that should be credited to the invention as distinguished from non-patented elements, the manufacturing process, business risks, or significant features or improvements added by the infringer.
14. The opinion testimony of qualified experts.
15. The amount that a licensor (such as the patentee) and a licensee (such as the infringer) would have agreed upon (at the time the infringement began) if both

## REMEDIES

had been reasonably and voluntarily trying to reach an agreement; that is, the amount which a prudent licensee—who desired, as a business proposition, to obtain a license to manufacture and sell a particular article embodying the patented invention—would have been willing to pay as a royalty and yet be able to make a reasonable profit and which amount would have been acceptable by a prudent patentee who was willing to grant a license.

*Georgia-Pacific Corp. v. U.S. Plywood Corp.*, 318 F. Supp. 1116, 1120 (S.D.N.Y. 1970). Must a party seeking an award of lost profits put forth evidence on all of these factors? Are all of these factors likely to be equally helpful or relevant in all cases?

### 1. Section 289

The Patent Act provides an additional remedy for certain acts of design patent infringement:

Whoever during the term of a patent for a design, without license of the owner, (1) applies the patented design, or any colorable imitation thereof, to any article of manufacture for the purpose of sale, or (2) sells or exposes for sale any article of manufacture to which such design or colorable imitation has been applied shall be liable to the owner to the extent of his total profit, but not less than \$250, recoverable in any United States district court having jurisdiction of the parties.

35 U.S.C. § 289. A design patent owner cannot recover damages under both § 289 and § 284 for the same act of infringement; they have to pick one or the other. *See, e.g., Catalina Lighting, Inc. v. Lamps Plus, Inc.*, 295 F.3d 1277, 1291 (Fed. Cir. 2002).

Importantly, this “total profits” remedy is only available for the aforementioned acts of design patent infringement. So don’t ask a court for § 289 damages in a utility patent case. *See Brown v. Generac Power Sys., Inc.*, No. 1:20-cv-22434, 2021 WL 1030229, at \*11 (S.D. Fla. Feb. 27, 2021), report and recommendation adopted, No. 1:20-cv-22434, 2021 WL 1022872 (S.D. Fla. Mar. 17, 2021) (ruling that attorneys violated Fed. R. Civ. P. 11(b)(2) by requesting § 289 damages in a utility patent complaint). How can you tell if a patent is a design patent? Contemporary design patents say “Design Patent” on the first page and their patent numbers begin with a “D.” Also, remember that design patents can only have one claim. So if a patent has more than one claim, it’s not a design patent.



In the next case, Apple asserted various utility and design patents against Samsung. The jury found that three of the asserted design patents were not invalid and infringed.

## CHAPTER 14

The first, U.S. Patent No. D618,677 (“the D’677 patent”), claimed the configuration and coloring of the flat, black front face of the iPhone, excluding the home button:

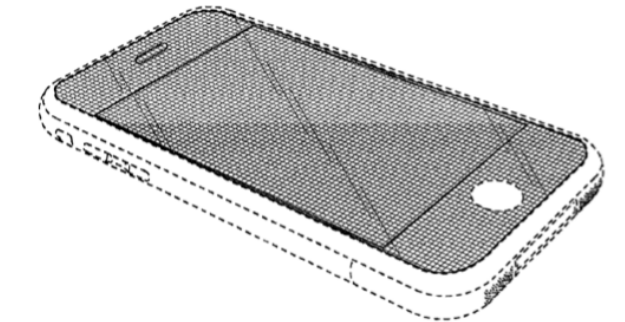

The second patent, U.S. Patent No. D593,087 (“the D’087 patent”), claimed a design for the configuration of the front, flat screen of the iPhone and the bezel:

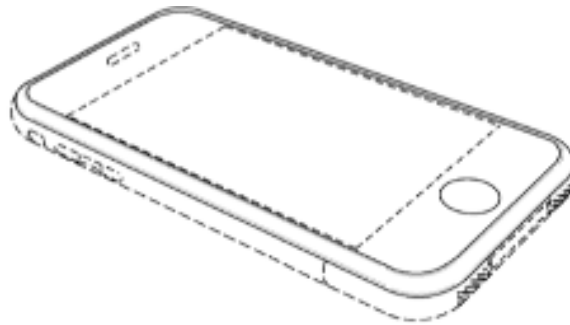

The third patent, U.S. Patent No. D604,305 (“the D’305 patent”), claimed this design for a screenshot from the iPhone’s graphical user interface:

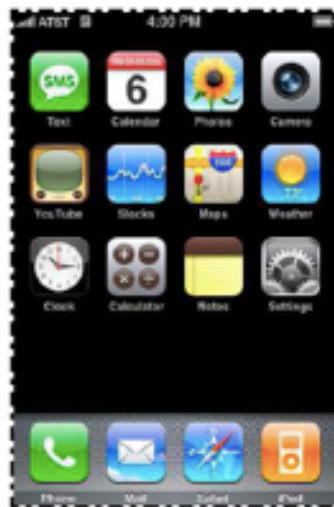

## REMEDIES

As can be seen from these illustrations, none of the asserted phone patents claimed a design for the entire shape or surface ornamentation of a phone. Nonetheless, the jury awarded Apple all profits that Samsung made from every phone the jury found infringed any of the three design patents. Those design patent awards made up a significant amount of the original verdict, which totaled over a billion dollars.

The Federal Circuit affirmed the design patent awards. As a matter of first impression, the court held that § 289 required disgorgement of the “total profits” from the entire infringing product—i.e., the total profits from whatever the defendant “sold separately,” even if the patented design only covered part of that product. *See Apple Inc. v. Samsung Elecs. Co.*, 786 F.3d 983, 1001-02 (Fed. Cir. 2015). The Supreme Court granted certiorari.

*Samsung Electronics Co., Ltd. v. Apple Inc.*  
137 S.Ct. 429 (2016)

Justice SOTOMAYOR delivered the opinion of the Court.

Section 289 of the Patent Act provides a damages remedy specific to design patent infringement. A person who manufactures or sells “any article of manufacture to which a patented design or colorable imitation has been applied shall be liable to the owner to the extent of his total profit.” 35 U.S.C. § 289. In the case of a design for a single-component product, such as a dinner plate, the product is the “article of manufacture” to which the design has been applied. In the case of a design for a multicomponent product, such as a kitchen oven, identifying the “article of manufacture” to which the design has been applied is a more difficult task.

This case involves the infringement of designs for smartphones. The United States Court of Appeals for the Federal Circuit identified the entire smartphone as the only permissible “article of manufacture” for the purpose of calculating § 289 damages because consumers could not separately purchase components of the smartphones. The question before us is whether that reading is consistent with § 289. We hold that it is not.

I

A

The federal patent laws have long permitted those who invent designs for manufactured articles to patent their designs. *See* Patent Act of 1842, § 3, 5 Stat. 543–544. Patent protection is available for a “new, original and ornamental design for an article of manufacture.” 35 U.S.C. § 171(a). A patentable design “gives a peculiar or distinctive appearance to the manufacture, or article to which it may be applied, or to which it gives form.” *Gorham Co. v. White*, 14 Wall. 511, 525 (1872). This Court has explained that a design

patent is infringed “if, in the eye of an ordinary observer, giving such attention as a purchaser usually gives, two designs are substantially the same.”

In 1885, this Court limited the damages available for design patent infringement. The statute in effect at the time allowed a holder of a design patent to recover “the actual damages sustained” from infringement. In *Dobson v. Hartford Carpet Co.*, 114 U.S. 439 (1885), the lower courts had awarded the holders of design patents on carpets damages in the amount of “the entire profit to the patent holders, per yard, in the manufacture and sale of carpets of the patented designs, and not merely the value which the designs contributed to the carpets.” This Court reversed the damages award and construed the statute to require proof that the profits were “due to” the design rather than other aspects of the carpets. *Id.*, at 444; see also *Dobson v. Dornan*, 118 U.S. 10, 17 (1886).

In 1887, in response to the *Dobson* cases, Congress enacted a specific damages remedy for design patent infringement. The new provision made it unlawful to manufacture or sell an article of manufacture to which a patented design or a colorable imitation thereof had been applied. It went on to make a design patent infringer “liable in the amount of” \$250 or “the total profit made by him from the manufacture or sale of the article or articles to which the design, or colorable imitation thereof, has been applied.”

The Patent Act of 1952 codified this provision in § 289.

## II

Section 289 allows a patent holder to recover the total profit an infringer makes from the infringement. It does so by first prohibiting the unlicensed “application” of a “patented design, or any colorable imitation thereof, to any article of manufacture for the purpose of sale” or the unlicensed sale or exposure to sale of “any article of manufacture to which a patented design or colorable imitation has been applied.” 35 U.S.C. § 289. It then makes a person who violates that prohibition “liable to the owner to the extent of his total profit, but not less than \$250.” “Total,” of course, means all. See *AMERICAN HERITAGE DICTIONARY* 1836 (5th ed. 2011) (“the whole amount of something; the entirety”). The “total profit” for which § 289 makes an infringer liable is thus all of the profit made from the prohibited conduct, that is, from the manufacture or sale of the “article of manufacture to which the patented design or colorable imitation has been applied.”

Arriving at a damages award under § 289 thus involves two steps. First, identify the “article of manufacture” to which the infringed design has been applied. Second, calculate the infringer's total profit made on that article of manufacture.

This case requires us to address a threshold matter: the scope of the term “article of manufacture.” The only question we resolve today is whether, in the case of a multicomponent product, the relevant “article of manufacture” must always be the end



## REMEDIES

product sold to the consumer or whether it can also be a component of that product. Under the former interpretation, a patent holder will always be entitled to the infringer's total profit from the end product. Under the latter interpretation, a patent holder will sometimes be entitled to the infringer's total profit from a component of the end product.

### A

The text resolves this case. The term "article of manufacture," as used in § 289, encompasses both a product sold to a consumer and a component of that product.

"Article of manufacture" has a broad meaning. An "article" is just "a particular thing." J. STORMONTH, *A DICTIONARY OF THE ENGLISH LANGUAGE* 53 (1885) (Stormonth); *see also* *AMERICAN HERITAGE DICTIONARY*, at 101 ("an individual thing or element of a class; a particular object or item"). And "manufacture" means "the conversion of raw materials by the hand, or by machinery, into articles suitable for the use of man" and "the articles so made." *STORMONTH* 589; *see also* *AMERICAN HERITAGE DICTIONARY*, at 1070 ("the act, craft, or process of manufacturing products, especially on a large scale" or "a product that is manufactured"). An article of manufacture, then, is simply a thing made by hand or machine.

So understood, the term "article of manufacture" is broad enough to encompass both a product sold to a consumer as well as a component of that product. A component of a product, no less than the product itself, is a thing made by hand or machine. That a component may be integrated into a larger product, in other words, does not put it outside the category of articles of manufacture.

### B

The Federal Circuit's narrower reading of "article of manufacture" cannot be squared with the text of § 289. The Federal Circuit found that components of the infringing smartphones could not be the relevant article of manufacture because consumers could not purchase those components separately from the smartphones. But, for the reasons given above, the term "article of manufacture" is broad enough to embrace both a product sold to a consumer and a component of that product, whether sold separately or not. Thus, reading "article of manufacture" in § 289 to cover only an end product sold to a consumer gives too narrow a meaning to the phrase.

The parties ask us to go further and resolve whether, for each of the design patents at issue here, the relevant article of manufacture is the smartphone, or a particular smartphone component. Doing so would require us to set out a test for identifying the relevant article of manufacture at the first step of the § 289 damages inquiry and to parse the record to apply that test in this case. The United States as amicus curiae suggested a test, but Samsung and Apple did not brief the issue. We decline to lay out a test for the

first step of the § 289 damages inquiry in the absence of adequate briefing by the parties. Doing so is not necessary to resolve the question presented in this case, and the Federal Circuit may address any remaining issues on remand.

III

The judgment of the United States Court of Appeals for the Federal Circuit is therefore reversed, and the case is remanded for further proceedings consistent with this opinion.

It is so ordered.

### Context & Application

1. In *Samsung*, the Federal Circuit insisted that the plain text of the § 289 compelled its interpretation. The Supreme Court ruled that the Federal Circuit's interpretation was wrong, also pointing to the plain text of the statute. Which court (if any) got it right? For more on the "total profits" remedy, including a deep dive into the history of the text, see Sarah Burstein, *The "Article of Manufacture" in 1887*, 32 BERKELEY TECH. L.J. 1, 1 (2017).

2. In *Samsung*, the Supreme Court rejected the Federal Circuit's "article of manufacture" test but refused to set forth a new test. To date, the Federal Circuit has not yet adopted a new test. How do you think the courts should handle this issue? For some suggestions, see Pamela Samuelson & Mark Gergen, *The Disgorgement Remedy of Design Patent Law*, 108 CAL. L. REV. 183, 184 (2020) and Sarah Burstein, *The "Article of Manufacture" Today*, 31 HARV. J.L. & TECH. 781, 835 (2018).

3. Today, disgorgement of profits is not available as a remedy for utility patent infringement. But that was not always the case. For many years, disgorgement was a remedy for utility patent infringement. But Congress amended the law in 1946 to eliminate the disgorgement remedy for utility patent owners. Why do you think Congress did that? Does it make sense to have disgorgement for design patents but not for utility patents? For more on the history of utility patents and disgorgement, see Caprice L. Roberts, *The Case for Restitution and Unjust Enrichment Remedies in Patent Law*, 14 LEWIS & CLARK L. REV. 653 (2010).

### D. Enhanced Damages and Attorney Fees

In certain situations, a patent holder may recover enhanced damages or attorneys fees in addition to compensatory damages. In addition to compensatory damages, 35 U.S.C. § 284 provides that "the court may increase the damages up to three times the amount found or assessed." Attorneys fees are provided for under 35 U.S.C. § 285: "The court in exceptional cases may award reasonable attorney fees to the prevailing party." These

## REMEDIES

provisions are permissive, allowing trial courts to exercise discretion in determining when they are appropriate. The Supreme Court has recently addressed both types of damages.

*Octane Fitness, LLC v. ICON Health & Fitness, Inc.*  
572 U.S. 545 (2014)

Justice SOTOMAYOR delivered the opinion of the Court.

Section 285 of the Patent Act authorizes a district court to award attorney's fees in patent litigation. It provides, in its entirety, that "the court in exceptional cases may award reasonable attorney fees to the prevailing party." 35 U.S.C. § 285. In *Brooks Furniture Mfg., Inc. v. Dutailier Int'l, Inc.*, 393 F.3d 1378 (2005), the United States Court of Appeals for the Federal Circuit held that "a case may be deemed exceptional" under § 285 only in two limited circumstances: "when there has been some material inappropriate conduct," or when the litigation is both "brought in subjective bad faith" and "objectively baseless." The question before us is whether the *Brooks Furniture* framework is consistent with the statutory text. We hold that it is not.

### I

#### A

Prior to 1946, the Patent Act did not authorize the awarding of attorney's fees to the prevailing party in patent litigation. Rather, the "American Rule" governed: "Each litigant paid his own attorney's fees, win or lose." In 1946, Congress amended the Patent Act to add a discretionary fee-shifting provision, then codified in § 70, which stated that a court "may in its discretion award reasonable attorney's fees to the prevailing party upon the entry of judgment in any patent case." 35 U.S.C. § 70 (1946 ed.).

Courts did not award fees under § 70 as a matter of course. They viewed the award of fees not "as a penalty for failure to win a patent infringement suit," but as appropriate "only in extraordinary circumstances." The provision enabled them to address "unfairness or bad faith in the conduct of the losing party, or some other equitable consideration of similar force," which made a case so unusual as to warrant fee-shifting.

Six years later, Congress amended the fee-shifting provision and recodified it as § 285. Whereas § 70 had specified that a district court could "in its discretion award reasonable attorney's fees to the prevailing party," the revised language of § 285 (which remains in force today) provides that "the court in exceptional cases may award reasonable attorney fees to the prevailing party." We have observed, in interpreting the damages provision of the Patent Act, that the addition of the phrase "exceptional cases" to § 285 was "for

purposes of clarification only.” And the parties agree that the recodification did not substantively alter the meaning of the statute.

For three decades after the enactment of § 285, courts applied it—as they had applied § 70—in a discretionary manner, assessing various factors to determine whether a given case was sufficiently “exceptional” to warrant a fee award. . . .

[For years,] the Federal Circuit, like the regional circuits before it, instructed district courts to consider the totality of the circumstances when making fee determinations under § 285.

In 2005, however, the Federal Circuit abandoned that holistic, equitable approach in favor of a more rigid and mechanical formulation. In *Brooks Furniture Mfg., Inc. v. Dutailier Int’l, Inc.*, 393 F.3d 1378 (2005), the court held that a case is “exceptional” under § 285 only “when there has been some material inappropriate conduct related to the matter in litigation, such as willful infringement, fraud or inequitable conduct in procuring the patent, misconduct during litigation, vexatious or unjustified litigation, conduct that violates Fed. R. Civ. P. 11, or like infractions.” “Absent misconduct in conduct of the litigation or in securing the patent,” the Federal Circuit continued, fees “may be imposed against the patentee only if both (1) the litigation is brought in subjective bad faith, and (2) the litigation is objectively baseless.” The Federal Circuit subsequently clarified that litigation is objectively baseless only if it is “so unreasonable that no reasonable litigant could believe it would succeed,” and that litigation is brought in subjective bad faith only if the plaintiff “actually knows” that it is objectively baseless.

Finally, *Brooks Furniture* held that because “there is a presumption that the assertion of infringement of a duly granted patent is made in good faith the underlying improper conduct and the characterization of the case as exceptional must be established by clear and convincing evidence.”

## B

The parties to this litigation are manufacturers of exercise equipment. The respondent, ICON Health & Fitness, Inc., owns U.S. Patent No. 6,019,710 (‘710 patent), which discloses an elliptical exercise machine that allows for adjustments to fit the individual stride paths of users. . . .

ICON sued Octane, alleging that the Q45 and Q47 infringed several claims of the ‘710 patent. The District Court granted Octane’s motion for summary judgment, concluding that Octane’s machines did not infringe ICON’s patent. Octane then moved for attorney’s fees under § 285. Applying the *Brooks Furniture* standard, the District Court denied Octane’s motion. . . . As to objective baselessness, the District Court explained that although it had rejected ICON’s infringement arguments, they were neither “frivolous”

## REMEDIES

nor “objectively baseless.” The court also found no subjective bad faith on ICON’s part, dismissing as insufficient both “the fact that ICON is a bigger company which never commercialized the ’710 patent” and an e-mail exchange between two ICON sales executives, which Octane had offered as evidence that ICON had brought the infringement action “as a matter of commercial strategy.”

ICON appealed the judgment of noninfringement, and Octane cross-appealed the denial of attorney’s fees. The Federal Circuit affirmed both orders. . . . We granted certiorari and now reverse.

...

## II

The framework established by the Federal Circuit in *Brooks Furniture* is unduly rigid, and it impermissibly encumbers the statutory grant of discretion to district courts.

## A

Our analysis begins and ends with the text of § 285: “The court in exceptional cases may award reasonable attorney fees to the prevailing party.” This text is patently clear. It imposes one and only one constraint on district courts’ discretion to award attorney’s fees in patent litigation: The power is reserved for “exceptional” cases.

The Patent Act does not define “exceptional,” so we construe it “in accordance with [its] ordinary meaning.” In 1952, when Congress used the word in § 285 (and today, for that matter), “exceptional” meant “uncommon,” “rare,” or “not ordinary.” WEBSTER’S NEW INTERNATIONAL DICTIONARY 889 (2d ed. 1934); *see also* 3 OXFORD ENGLISH DICTIONARY 374 (1933) (defining “exceptional” as “out of the ordinary course,” “unusual,” or “special”); MERRIAM–WEBSTER’S COLLEGIATE DICTIONARY 435 (11th ed. 2008) \*554 (defining “exceptional” as “rare”).

We hold, then, that an “exceptional” case is simply one that stands out from others with respect to the substantive strength of a party’s litigating position (considering both the governing law and the facts of the case) or the unreasonable manner in which the case was litigated. District courts may determine whether a case is “exceptional” in the case-by-case exercise of their discretion, considering the totality of the circumstances. As in the comparable context of the Copyright Act, “there is no precise rule or formula for making these determinations, but instead equitable discretion should be exercised ‘in light of the considerations we have identified.’”

B

1

The Federal Circuit’s formulation is overly rigid. Under the standard crafted in *Brooks Furniture*, a case is “exceptional” only if a district court either finds litigation-related misconduct of an independently sanctionable magnitude or determines that the litigation was both “brought in subjective bad faith” and “objectively baseless.” This formulation superimposes an inflexible framework onto statutory text that is inherently flexible.

For one thing, the first category of cases in which the Federal Circuit allows fee awards—those involving litigation misconduct or certain other misconduct—appears to extend largely to independently sanctionable conduct. But sanctionable conduct is not the appropriate benchmark. Under the standard announced today, a district court may award fees in the rare case in which a party’s unreasonable conduct—while not necessarily independently sanctionable—is nonetheless so “exceptional” as to justify an award of fees.

The second category of cases in which the Federal Circuit allows fee awards is also too restrictive. In order for a case to fall within this second category, a district court must determine both that the litigation is objectively baseless and that the plaintiff brought it in subjective bad faith. But a case presenting either subjective bad faith or exceptionally meritless claims may sufficiently set itself apart from mine-run cases to warrant a fee award.

2

We reject *Brooks Furniture* for another reason: It is so demanding that it would appear to render § 285 largely superfluous. We have long recognized a common-law exception to the general “American rule” against fee-shifting—an exception, “inherent” in the “power of the courts” that applies for “willful disobedience of a court order” or “when the losing party has acted in bad faith, vexatiously, wantonly, or for oppressive reasons.” . . .

3

Finally, we reject the Federal Circuit’s requirement that patent litigants establish their entitlement to fees under § 285 by “clear and convincing evidence,” *Brooks Furniture*, 393 F.3d, at 1382. We have not interpreted comparable fee-shifting statutes to require proof of entitlement to fees by clear and convincing evidence. . . . And nothing in § 285 justifies such a high standard of proof. Section 285 demands a simple discretionary inquiry; it imposes no specific evidentiary burden, much less such a high one. Indeed, patent-infringement litigation has always been governed by a preponderance of the evidence standard, and that is the “standard generally applicable in civil actions,” because it “allows both parties to share the risk of error in roughly equal fashion.”

## REMEDIES

For the foregoing reasons, the judgment of the United States Court of Appeals for the Federal Circuit is reversed, and the case is remanded for further proceedings consistent with this opinion.

*Halo Electronics, Inc. v. Pulse Electronics, Inc.*  
136 S.Ct. 1923 (2016)

Chief Justice ROBERTS delivered the opinion of the Court.

Section 284 of the Patent Act provides that, in a case of infringement, courts “may increase the damages up to three times the amount found or assessed.” 35 U.S.C. § 284. In *In re Seagate Technology, LLC*, 497 F.3d 1360 (2007) (*en banc*), the United States Court of Appeals for the Federal Circuit adopted a two-part test for determining when a district court may increase damages pursuant to § 284. Under *Seagate*, a patent owner must first “show by clear and convincing evidence that the infringer acted despite an objectively high likelihood that its actions constituted infringement of a valid patent.” Second, the patentee must demonstrate, again by clear and convincing evidence, that the risk of infringement “was either known or so obvious that it should have been known to the accused infringer.” The question before us is whether this test is consistent with § 284. We hold that it is not.

I

A

Enhanced damages are as old as U.S. patent law. The Patent Act of 1793 mandated treble damages in any successful infringement suit. In the Patent Act of 1836, however, Congress changed course and made enhanced damages discretionary, specifying that “it shall be in the power of the court to render judgment for any sum above the amount found by the verdict not exceeding three times the amount thereof, according to the circumstances of the case.” In construing that new provision, this Court explained that the change was prompted by the “injustice” of subjecting a “defendant who acted in ignorance or good faith” to the same treatment as the “wanton and malicious pirate.” *Seymour v. McCormick*, 16 How. 480, 488 (1854). There “is no good reason,” we observed, “why taking a man’s property in an invention should be trebly punished, while the measure of damages as to other property is single and actual damages.” But “where the injury is wanton or malicious, a jury may inflict vindictive or exemplary damages, not to recompense the plaintiff, but to punish the defendant.”

The Court followed the same approach in other decisions applying the 1836 Act, finding enhanced damages appropriate, for instance, “where the wrong had been done,

under aggravated circumstances,” but not where the defendant “appeared in truth to be ignorant of the existence of the patent right, and did not intend any infringement.”

In 1870, Congress amended the Patent Act, but preserved district court discretion to award up to treble damages “according to the circumstances of the case.” We continued to describe enhanced damages as “vindictive or punitive,” which the court may “inflict” when “the circumstances of the case appear to require it.” At the same time, we reiterated that there was no basis for increased damages where “there is no pretence of any wanton and wilful breach” and “nothing that suggests punitive damages, or that shows wherein the defendant was damnified other than by the loss of the profits which the plaintiff received.”

Courts of Appeals likewise characterized enhanced damages as justified where the infringer acted deliberately or willfully. . . .

Some early decisions did suggest that enhanced damages might serve to compensate patentees as well as to punish infringers. Such statements, however, were not for the ages, in part because the merger of law and equity removed certain procedural obstacles to full compensation absent enhancement. . . . In the main, moreover, the references to compensation concerned costs attendant to litigation. . . . That concern dissipated with the enactment in 1952 of 35 U.S.C. § 285, which authorized district courts to award reasonable attorney’s fees to prevailing parties in “exceptional cases” under the Patent Act. *See Octane Fitness, LLC v. ICON Health & Fitness Inc.*, 134 S.Ct. 1749, 1755 (2014).

It is against this backdrop that Congress, in the 1952 codification of the Patent Act, enacted § 284. “The stated purpose” of the 1952 revision “was merely reorganization in language to clarify the statement of the statutes.” This Court accordingly described § 284—consistent with the history of enhanced damages under the Patent Act—as providing that “punitive or ‘increased’ damages” could be recovered “in a case of willful or bad-faith infringement.”

## B

In 2007, the Federal Circuit decided *Seagate* and fashioned the test for enhanced damages now before us. Under *Seagate*, a plaintiff seeking enhanced damages must show that the infringement of his patent was “willful.” 497 F.3d, at 1368. The Federal Circuit announced a two-part test to establish such willfulness: First, “a patentee must show by clear and convincing evidence that the infringer acted despite an objectively high likelihood that its actions constituted infringement of a valid patent,” without regard to “the state of mind of the accused infringer.” This objectively defined risk is to be “determined by the record developed in the infringement proceedings.” “Objective recklessness will not be found” at this first step if the accused infringer, during the infringement proceedings, “raises a ‘substantial question’ as to the validity or



## REMEDIES

noninfringement of the patent.” That categorical bar applies even if the defendant was unaware of the arguable defense when he acted.

Second, after establishing objective recklessness, a patentee must show—again by clear and convincing evidence—that the risk of infringement “was either known or so obvious that it should have been known to the accused infringer.” Only when both steps have been satisfied can the district court proceed to consider whether to exercise its discretion to award enhanced damages.

### C

Petitioner Halo Electronics, Inc., and respondents Pulse Electronics, Inc., and Pulse Electronics Corporation (collectively, Pulse) supply electronic components. . . .

In 2007, Halo sued Pulse. The jury found that Pulse had infringed Halo’s patents, and that there was a high probability it had done so willfully. The District Court, however, declined to award enhanced damages under § 284, after determining that Pulse had at trial presented a defense that “was not objectively baseless, or a ‘sham.’” Thus, the court concluded, Halo had failed to show objective recklessness under the first step of *Seagate*. The Federal Circuit affirmed.

. . .

We granted certiorari . . . and now vacate and remand.

### II

#### A

The pertinent text of § 284 provides simply that “the court may increase the damages up to three times the amount found or assessed.” 35 U.S.C. § 284. That language contains no explicit limit or condition, and we have emphasized that the “word ‘may’ clearly connotes discretion.”

At the same time, “discretion is not whim.” “In a system of laws discretion is rarely without limits,” even when the statute “does not specify any limits upon the district courts’ discretion.” “A motion to a court’s discretion is a motion, not to its inclination, but to its judgment; and its judgment is to be guided by sound legal principles.” Thus, although there is “no precise rule or formula” for awarding damages under § 284, a district court’s “discretion should be exercised in light of the considerations” underlying the grant of that discretion.

Awards of enhanced damages under the Patent Act over the past 180 years establish that they are not to be meted out in a typical infringement case, but are instead designed as a “punitive” or “vindictive” sanction for egregious infringement behavior. The sort of conduct warranting enhanced damages has been variously described in our cases as

willful, wanton, malicious, bad-faith, deliberate, consciously wrongful, flagrant, or—indeed—characteristic of a pirate. District courts enjoy discretion in deciding whether to award enhanced damages, and in what amount. But through nearly two centuries of discretionary awards and review by appellate tribunals, “the channel of discretion has narrowed” so that such damages are generally reserved for egregious cases of culpable behavior.

## B

The *Seagate* test reflects, in many respects, a sound recognition that enhanced damages are generally appropriate under § 284 only in egregious cases. That test, however, “is unduly rigid, and it impermissibly encumbers the statutory grant of discretion to district courts.” *Octane Fitness*, 134 S.Ct., at 1755 (construing § 285 of the Patent Act). In particular, it can have the effect of insulating some of the worst patent infringers from any liability for enhanced damages.

## 1

The principal problem with *Seagate*’s two-part test is that it requires a finding of objective recklessness in every case before district courts may award enhanced damages. Such a threshold requirement excludes from discretionary punishment many of the most culpable offenders, such as the “wanton and malicious pirate” who intentionally infringes another’s patent—with no doubts about its validity or any notion of a defense—for no purpose other than to steal the patentee’s business. *Seymour*, 16 How., at 488. Under *Seagate*, a district court may not even consider enhanced damages for such a pirate, unless the court first determines that his infringement was “objectively” reckless. In the context of such deliberate wrongdoing, however, it is not clear why an independent showing of objective recklessness—by clear and convincing evidence, no less—should be a prerequisite to enhanced damages.

Our recent decision in *Octane Fitness* arose in a different context but points in the same direction. In that case . . . [we held that] a case presenting “subjective bad faith” alone could “sufficiently set itself apart from mine-run cases to warrant a fee award.” So too here. The subjective willfulness of a patent infringer, intentional or knowing, may warrant enhanced damages, without regard to whether his infringement was objectively reckless.

The *Seagate* test aggravates the problem by making dispositive the ability of the infringer to muster a reasonable (even though unsuccessful) defense at the infringement trial. The existence of such a defense insulates the infringer from enhanced damages, even if he did not act on the basis of the defense or was even aware of it. Under that standard, someone who plunders a patent—infringing it without any reason to suppose his conduct is arguably defensible—can nevertheless escape any comeuppance under § 284 solely on the strength of his attorney’s ingenuity.

## REMEDIES

But culpability is generally measured against the knowledge of the actor at the time of the challenged conduct. . . .

Section 284 allows district courts to punish the full range of culpable behavior. Yet none of this is to say that enhanced damages must follow a finding of egregious misconduct. As with any exercise of discretion, courts should continue to take into account the particular circumstances of each case in deciding whether to award damages, and in what amount. Section 284 permits district courts to exercise their discretion in a manner free from the inelastic constraints of the *Seagate* test. Consistent with nearly two centuries of enhanced damages under patent law, however, such punishment should generally be reserved for egregious cases typified by willful misconduct.

### 2

The *Seagate* test is also inconsistent with § 284 because it requires clear and convincing evidence to prove recklessness. On this point *Octane Fitness* is again instructive. . . . Like § 285, § 284 “imposes no specific evidentiary burden, much less such a high one.” And the fact that Congress expressly erected a higher standard of proof elsewhere in the Patent Act but not in § 284, is telling. Furthermore, nothing in historical practice supports a heightened standard. As we explained in *Octane Fitness*, “patent-infringement litigation has always been governed by a preponderance of the evidence standard.” Enhanced damages are no exception.

### III

At the end of the day, respondents’ main argument for retaining the *Seagate* test comes down to a matter of policy. Respondents and their amici are concerned that allowing district courts unlimited discretion to award up to treble damages in infringement cases will impede innovation as companies steer well clear of any possible interference with patent rights. They also worry that the ready availability of such damages will embolden “trolls.” Trolls, in the patois of the patent community, are entities that hold patents for the primary purpose of enforcing them against alleged infringers, often exacting outsized licensing fees on threat of litigation.

Respondents are correct that patent law reflects “a careful balance between the need to promote innovation” through patent protection, and the importance of facilitating the “imitation and refinement through imitation” that are “necessary to invention itself and the very lifeblood of a competitive economy.” *Bonito Boats, Inc. v. Thunder Craft Boats, Inc.*, 489 U.S. 141, 146 (1989). That balance can indeed be disrupted if enhanced damages are awarded in garden-variety cases. As we have explained, however, they should not be. The seriousness of respondents’ policy concerns cannot justify imposing an artificial construct such as the *Seagate* test on the discretion conferred under § 284.

## CHAPTER 14

Section 284 gives district courts the discretion to award enhanced damages against those guilty of patent infringement. In applying this discretion, district courts are “to be guided by the sound legal principles” developed over nearly two centuries of application and interpretation of the Patent Act. Those principles channel the exercise of discretion, limiting the award of enhanced damages to egregious cases of misconduct beyond typical infringement. The *Seagate* test, in contrast, unduly confines the ability of district courts to exercise the discretion conferred on them. Because both cases before us were decided under the *Seagate* framework, we vacate the judgments of the Federal Circuit and remand the cases for proceedings consistent with this opinion.

It is so ordered.

### Context & Application

1. In *Octane Fitness*, the Court states that “[t]he Federal Circuit’s formulation is overly rigid.” Does this sound familiar from other recent Supreme Court cases? Are there some situations in which a flexible rule makes more sense and some in which it makes less sense for patent law? What are the characteristics of these different situations?

2. Note that, unlike an award of damages made under § 284, an award of damages made under § 289 cannot be trebled. *Braun Inc. v. Dynamics Corp. of Am.*, 975 F.2d 815, 824 (Fed. Cir. 1992).