



STARGATE

Inflatable Crew-lock

Critical Design Review



Life at OSU

- **Oklahoma Weather Update**
- **Senior Capstone – Flight Tests**
- **Senior Capstone – Project Wars**

CDR POC: Adam Morgan



Oklahoma Weather Update



Oklahoma Weather

December

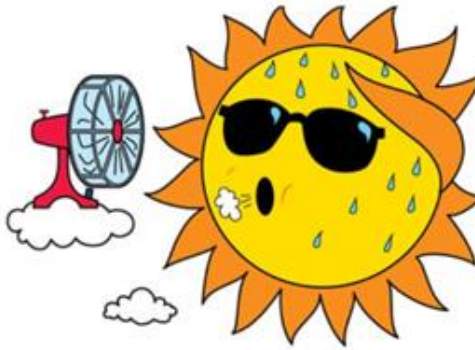

Early January



Late January

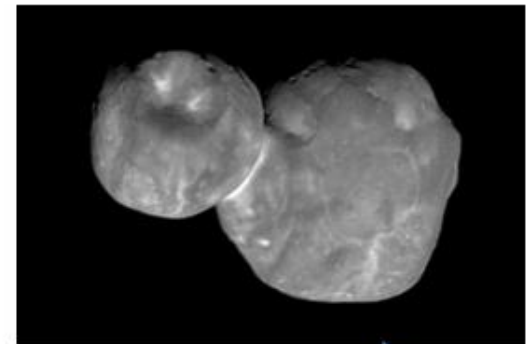

Average Temperature



Senior Capstone Flight Tests

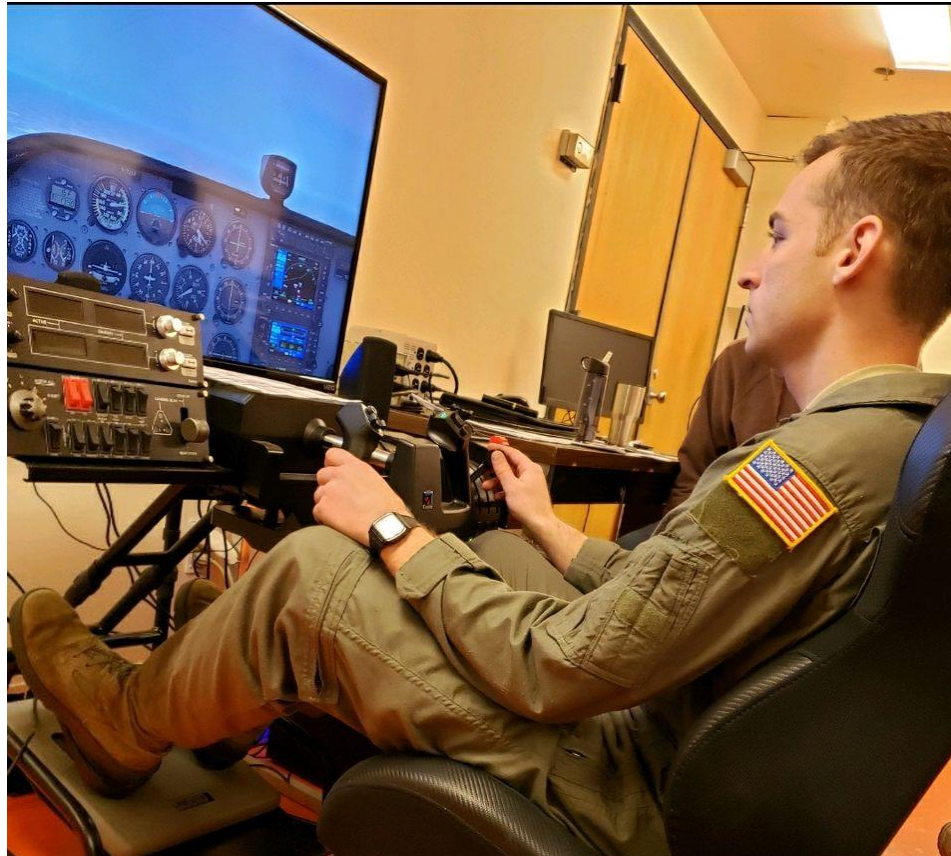

Flight tests in the Cessna 172 are a part of OSU's BAE capstone coursework. Simulator flights and data collection this month followed by crewed flights in March.



Senior Capstone Project Competition

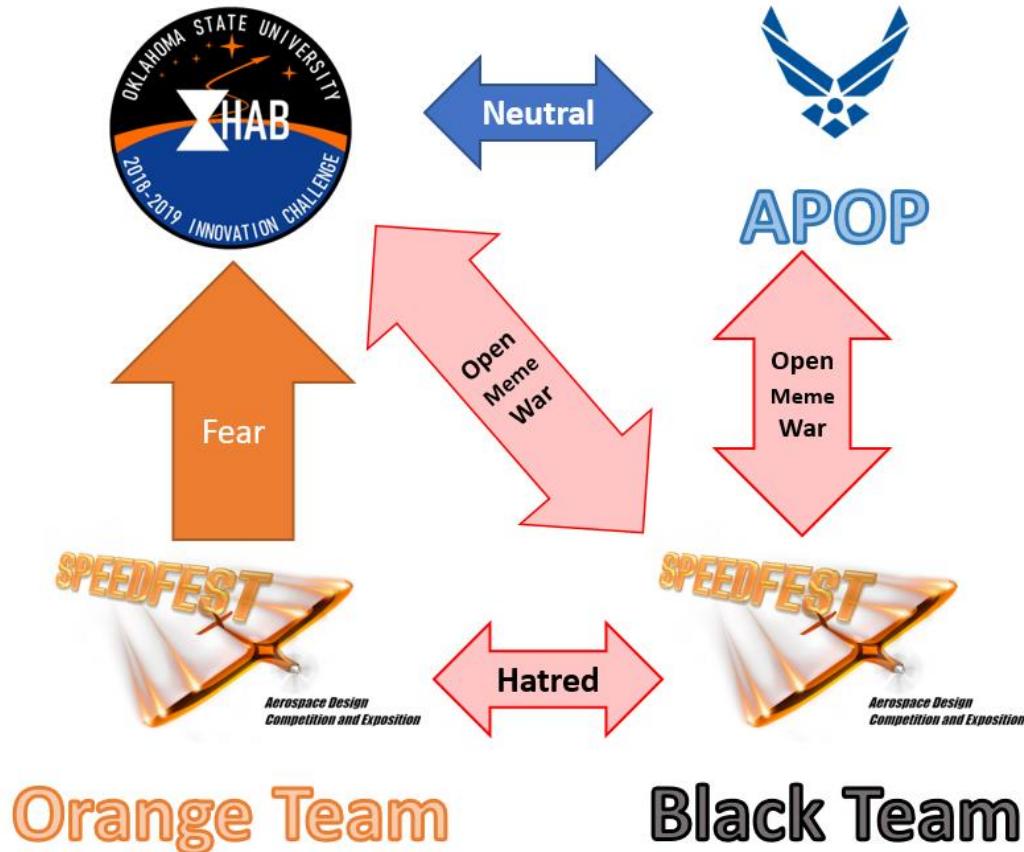

Major Capstone Groups

Speedfest (drones), APOP (Small Scale Turbojet Propulsion), Rocketry



Overview



- **Administrative Overview**
 - CDR POC: Justin Duewall
 - **Analog System Design Solution**
 - CDR POC: Austin Bennett
 - **Research and Development**
 - CDR POC: Madison Whiteley
 - **System Operations and Interfacing**
 - CDR POC: Josh Pankratz
 - **Administrative Review**
 - CDR POC: Michael Raymer
-



Administrative Overview



- **Requirements Review**
- **PDR Documentation Review**
- **STARGATE Introduction**

CDR POC: Justin Duewall



Justin Duewall



Hometown

Bryan, Texas

Major

Aerospace and Mechanical
Engineering

Minor

Aerospace Studies

Hobbies

Playing Sports (all of them),
Writing, and Reading

Interesting Fact:

Commissioning into the Air
Force in May

Getting my Masters in
Aerospace Engineering at AFIT

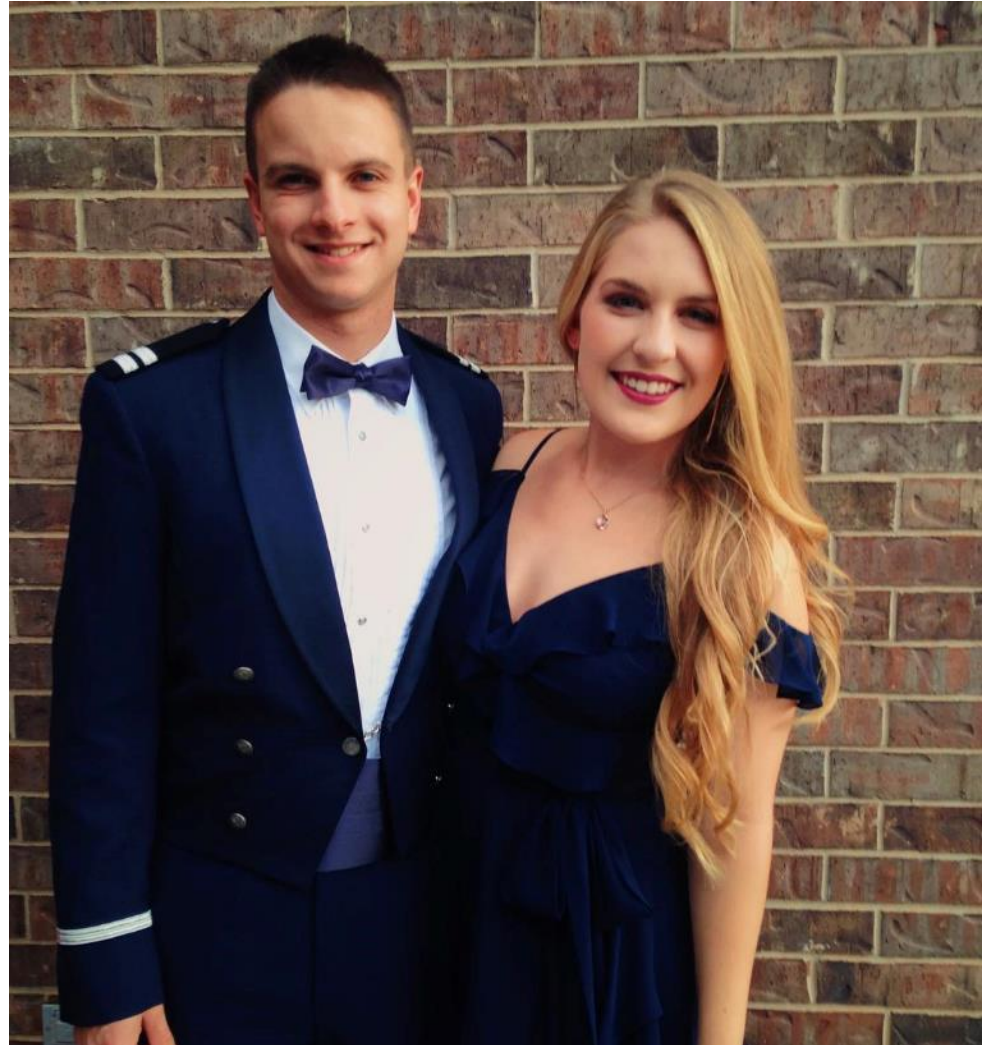



Requirements Review Primary Objectives



- **Deployment Test:** Demonstrate operations through a series of deployment tests
 - Include packaging concept and deployment operations
 - Crew lock inflates with some manual/mechanical assistance assisting low pressure inflation

 - **Internal Operations Tests:** Demonstrate crew lock operations for EVA prep
 - Non-pressurized state when open to prototypes/mockups
 - Deploy the crew lock in an unpressurized state with some internal structure
 - Allow crew to transfer between module and other notional prototypes available during test.
 - Crew interaction w/ NASA and university EVA prep payloads
-



Requirements Review

SDR to CDR

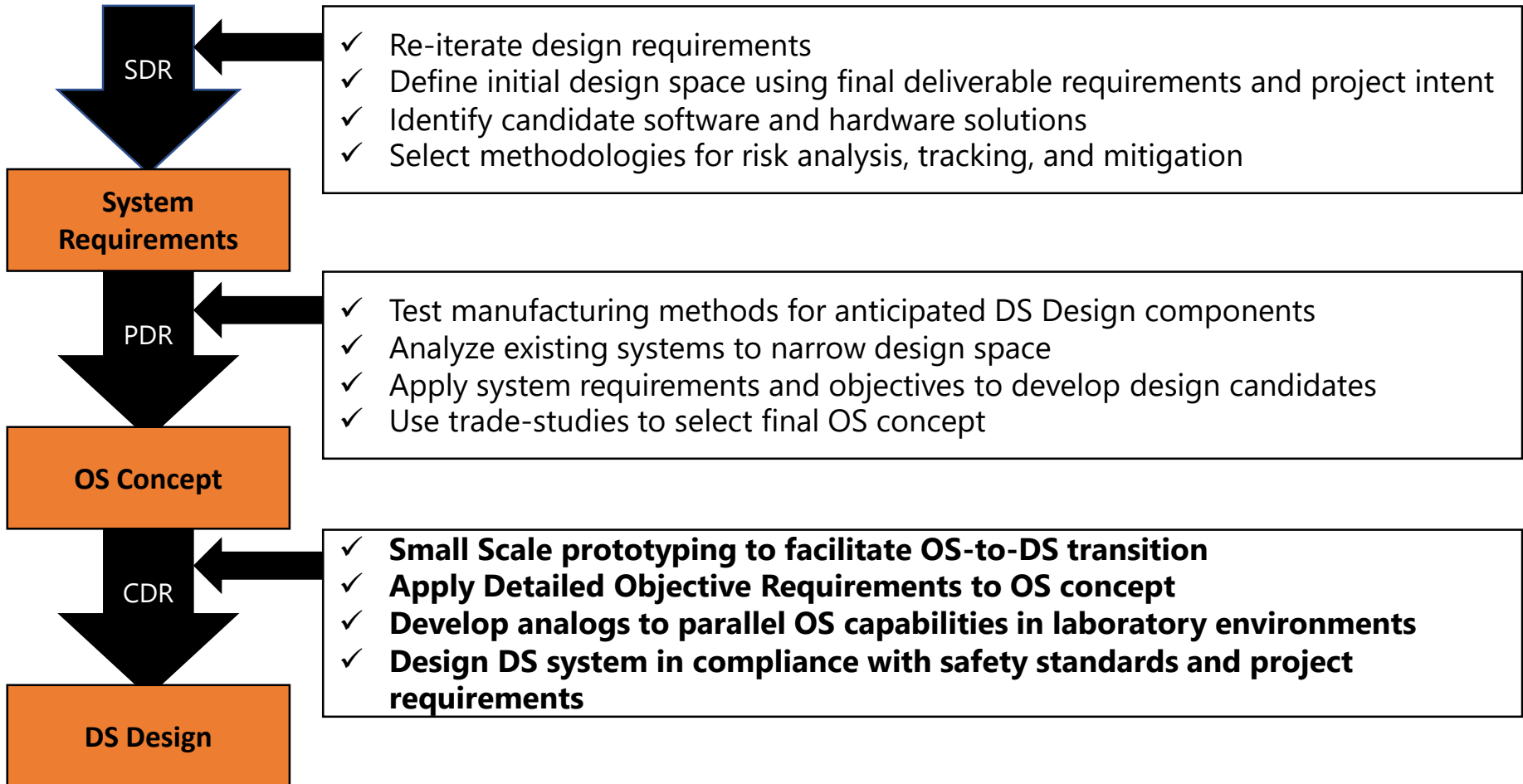



Documentation Review Schedule through CDR

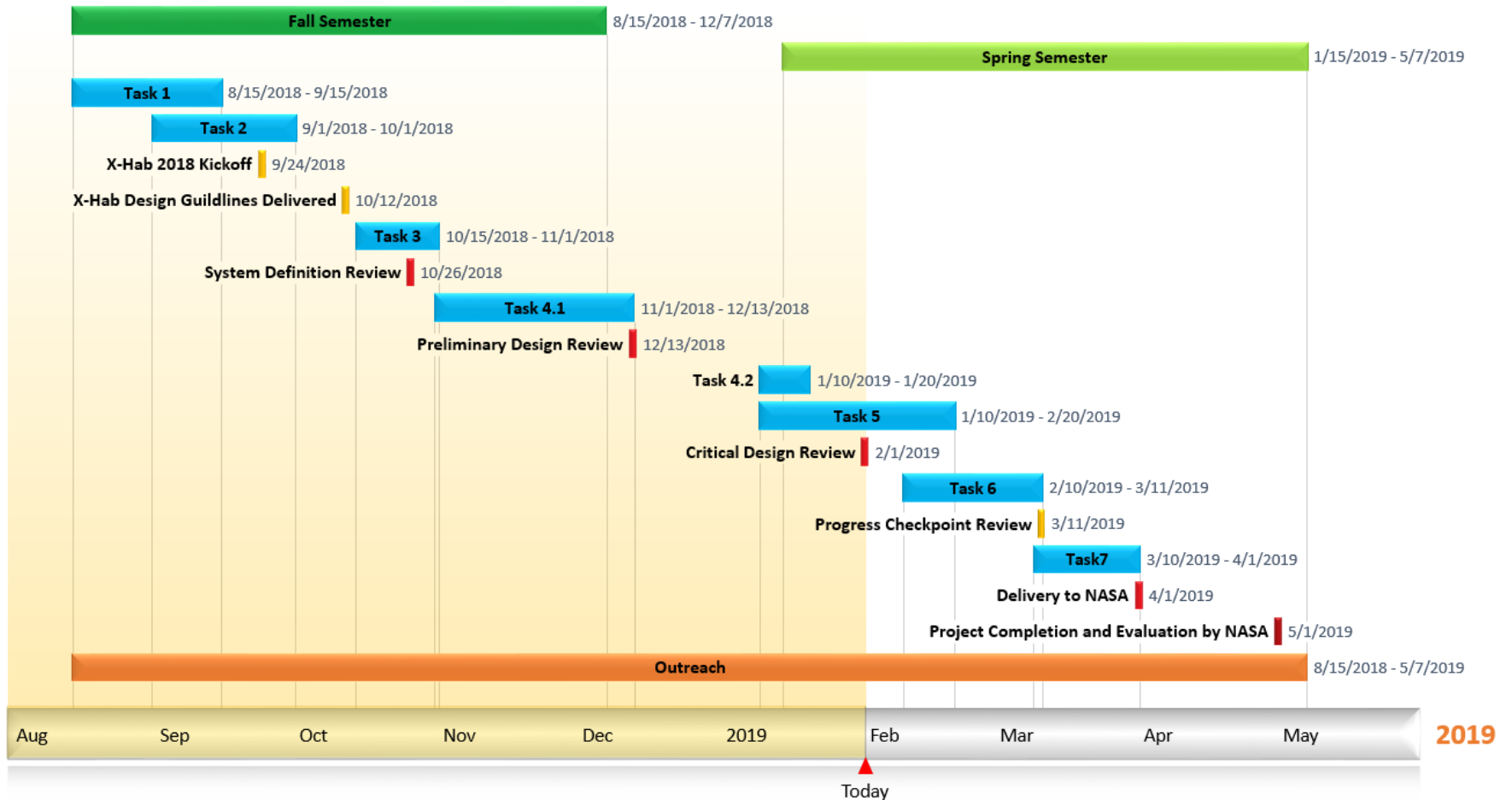



Documentation Review PDR *Projected* Cost Analysis



Area of Cost	Budget Percent	Description of Use
DS Construction Materials	20%	Construction of analog demonstration system
Tool/Supplies	5%	Needed for use in construction
Electronic Hardware	15%	Electronic controlling units and their respective interfaces
Electronic Software	5%	Operating the electronic controls hardware for automated deployment demonstrations
Travel	42%	Travel expenses such as food, gas, and lodging
Misc.	13%	



STARGATE Demonstrator

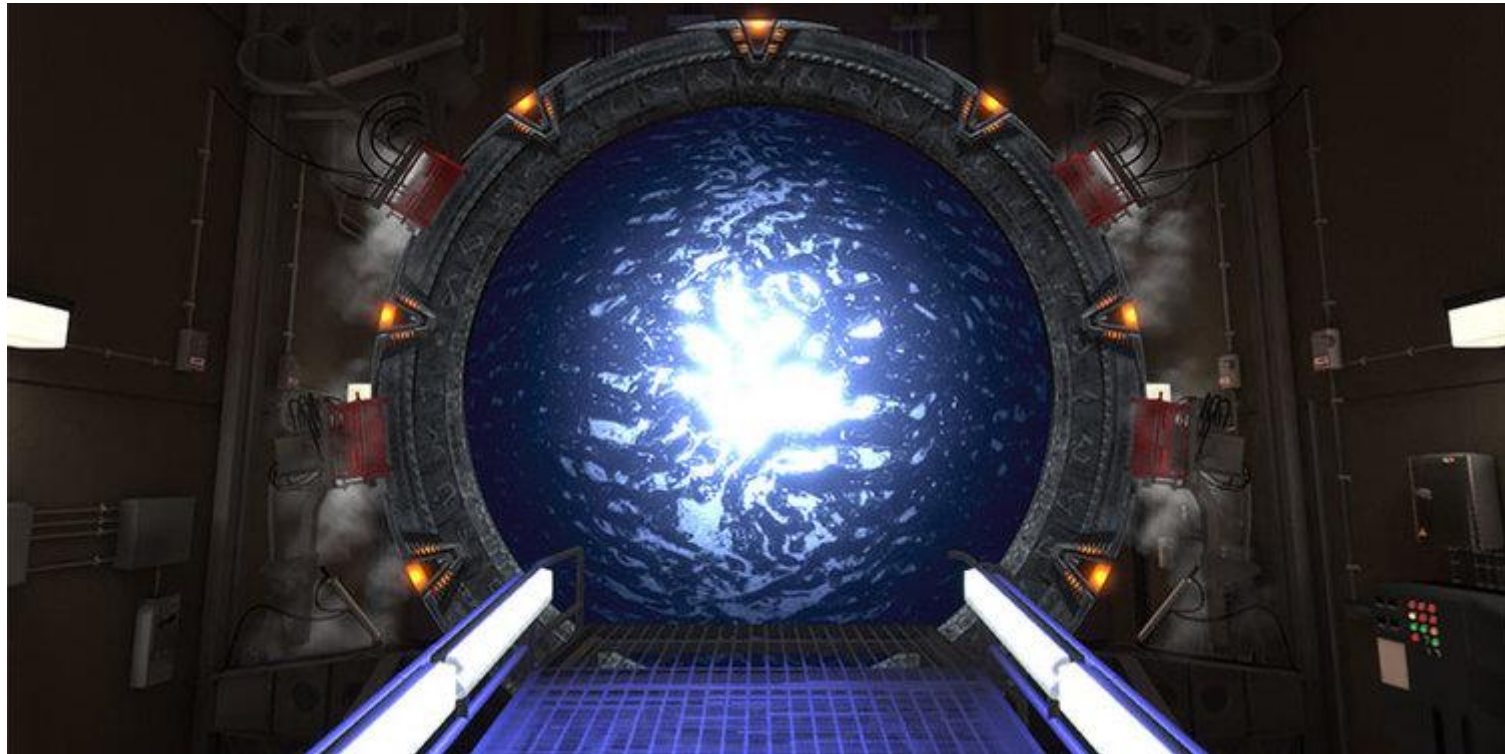



STARGATE Introduction



PDR

OS Design Concept

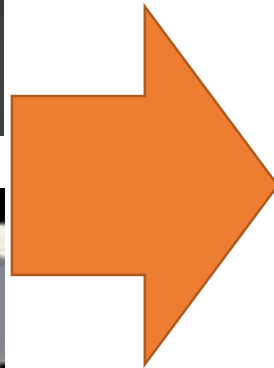
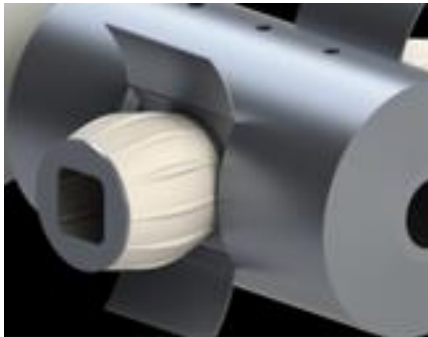
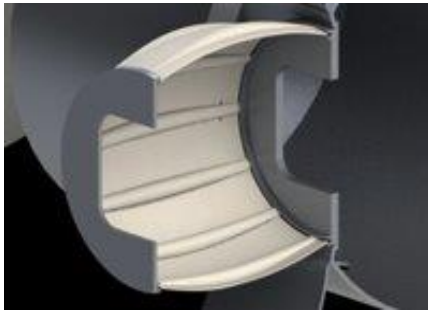

SDR

STARGATE Demonstrator

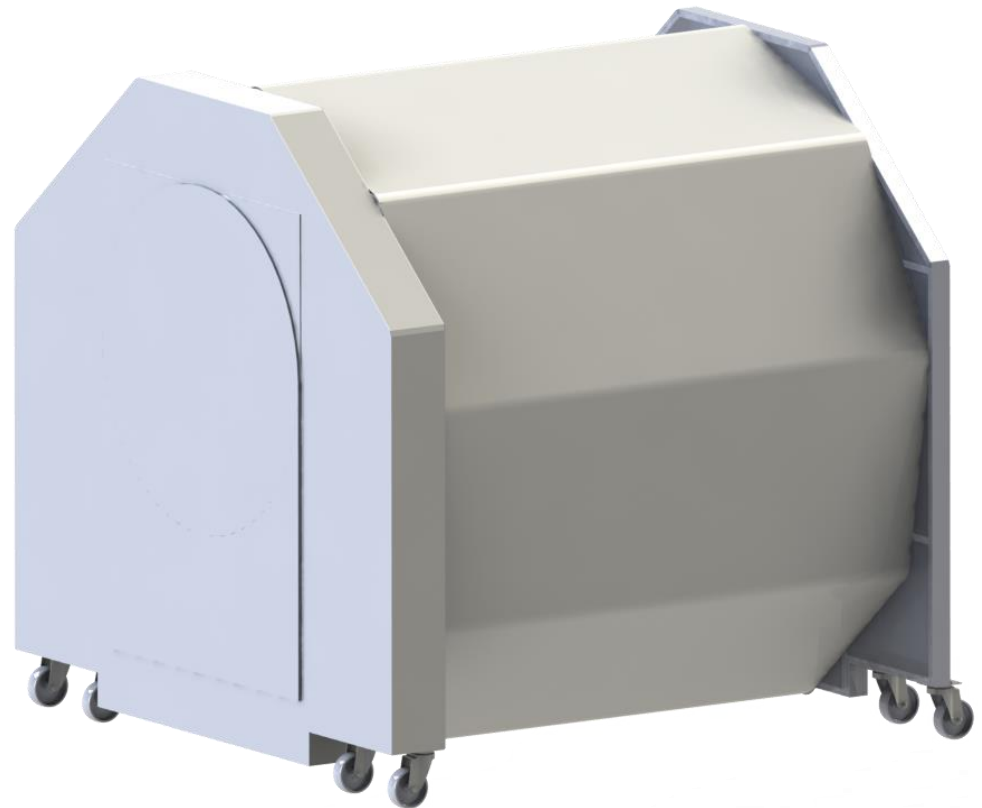



Stargate Introduction CONOPS

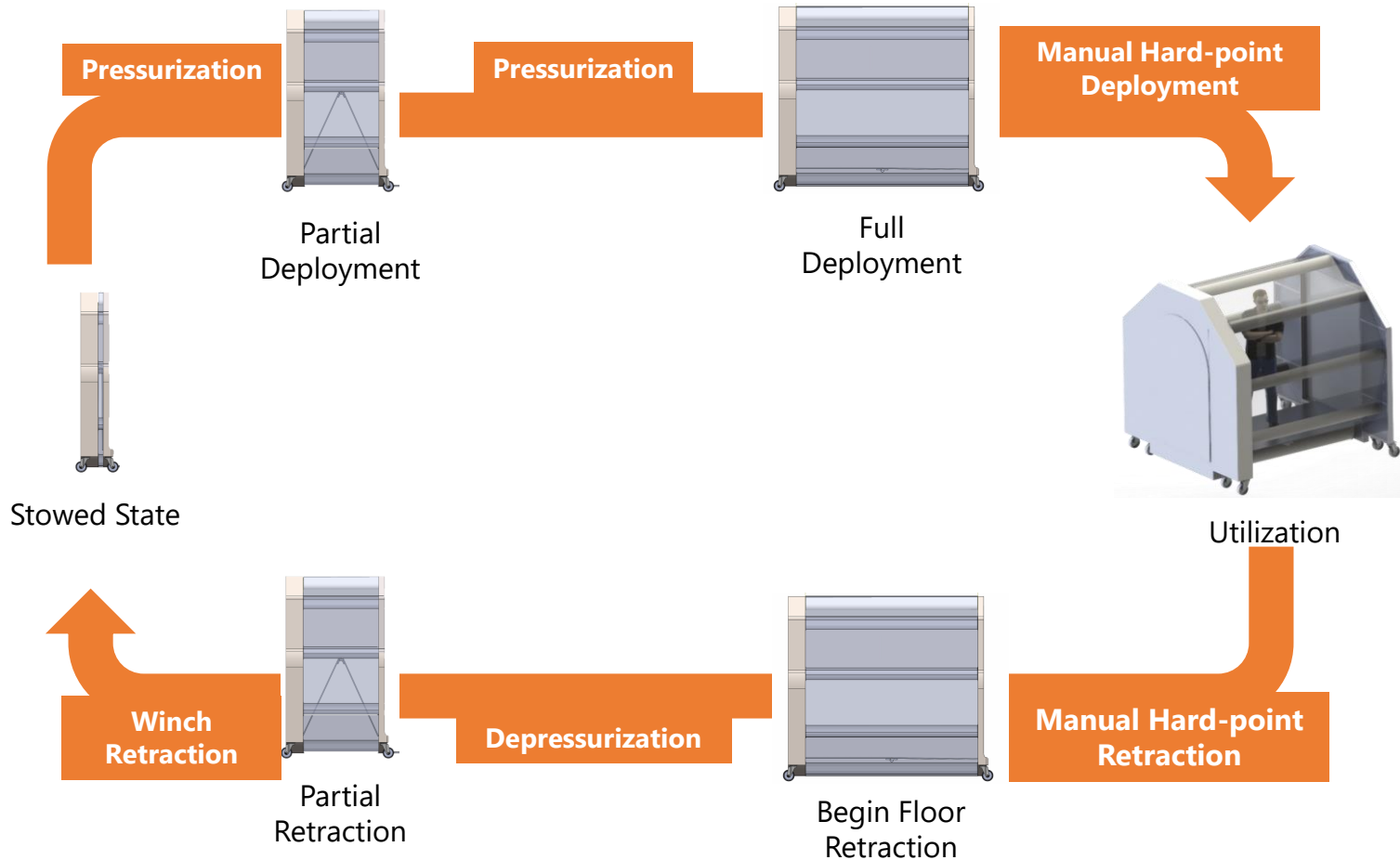



STARGATE Introduction Component Terminology



Major Components

1. Dock

- a) Frame
- b) Wheel-Base
- c) Door
- d) Paneling

2. Span

- a) Air beams
- b) Exterior Wall
- c) Interior Wall
- d) Floor

3. Bulkhead

- a) Frame
- b) Wheel Base
- c) Door
- d) Paneling

Front  Back

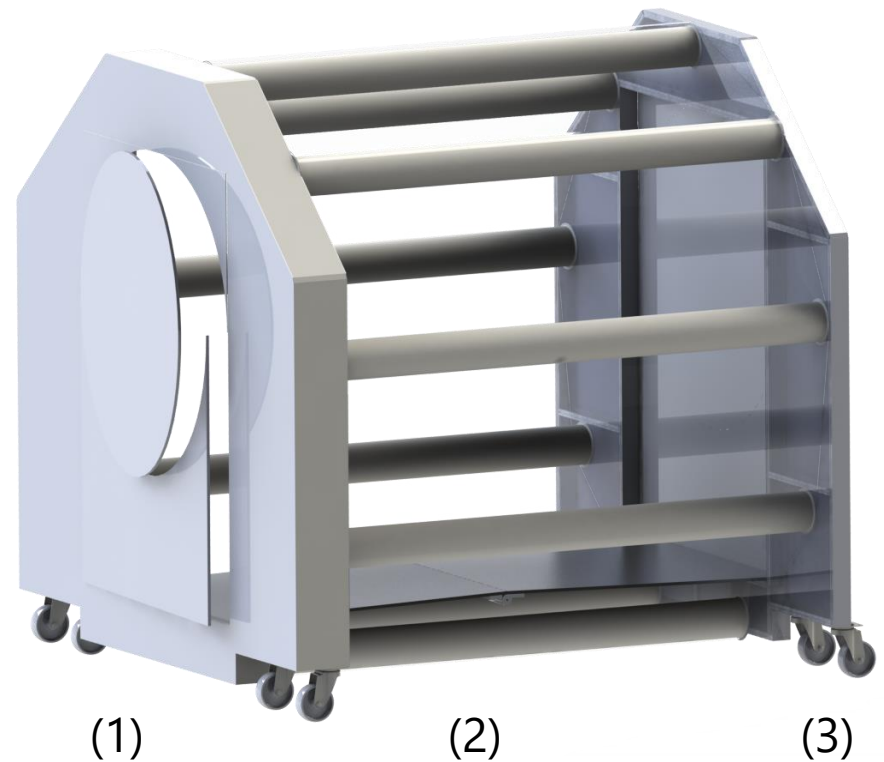



STARGATE Design Solution



- **STARGATE Design Solution Components**
 - **STARGATE System Operations**
-

CDR POC: Austin Bennett



Austin Bennett



Hometown:

Oklahoma City, Oklahoma

Major:

Mechanical &
Aerospace Engineering

Hobbies:

Board Games

Building FPV Drones

Video Games

Disc Golf





STARGATE Design Solution Design Philosophies



- **Maximize interior volume while retaining collapsibility**
 - Optimized floor space and head room, compact systems
- **Ease of use by automating system operations**
 - Automatic floor deployment
 - Self-contained systems
- **Incorporating quality of life features**
 - Dutch Doors and hardpoint mounts
 - Variable system configurations
- **Retaining operational system characteristics while meeting demonstrational design requirements**



STARGATE Design Solution Overview



- **Dock Frame**
- **Span Configuration**
 - Air-beam and Wall Construction
 - Floor
- **Bulkhead Frame**
- **Other Design Elements**
 - Hardpoints
 - Wheelbase
 - System Integration

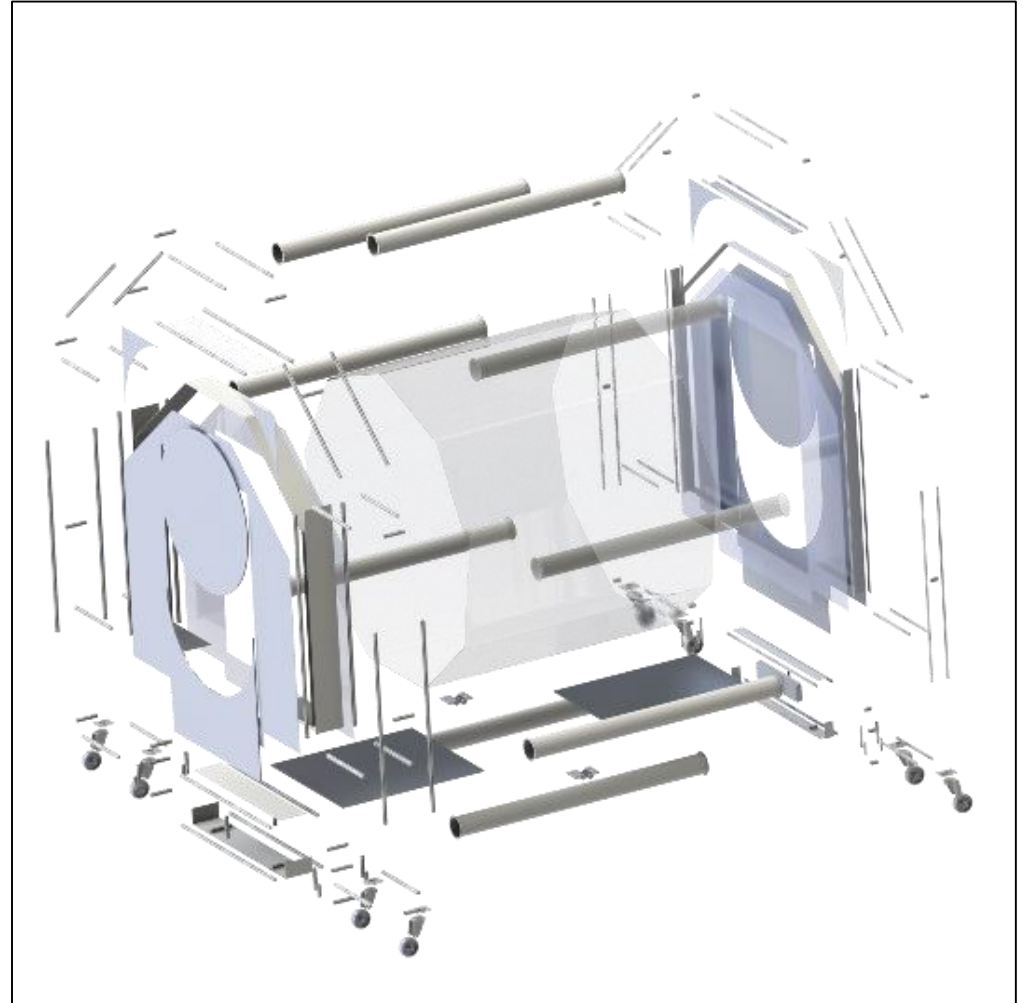



STARGATE Design Solution Dock Frame



- **Steel 8020 Frame**
- **Plastic Paneling**
- **Systems within:**
 - **Air tanks**
 - **Compressor**
 - **Winches**
 - **Electronics**
 - **Storage & Misc.**

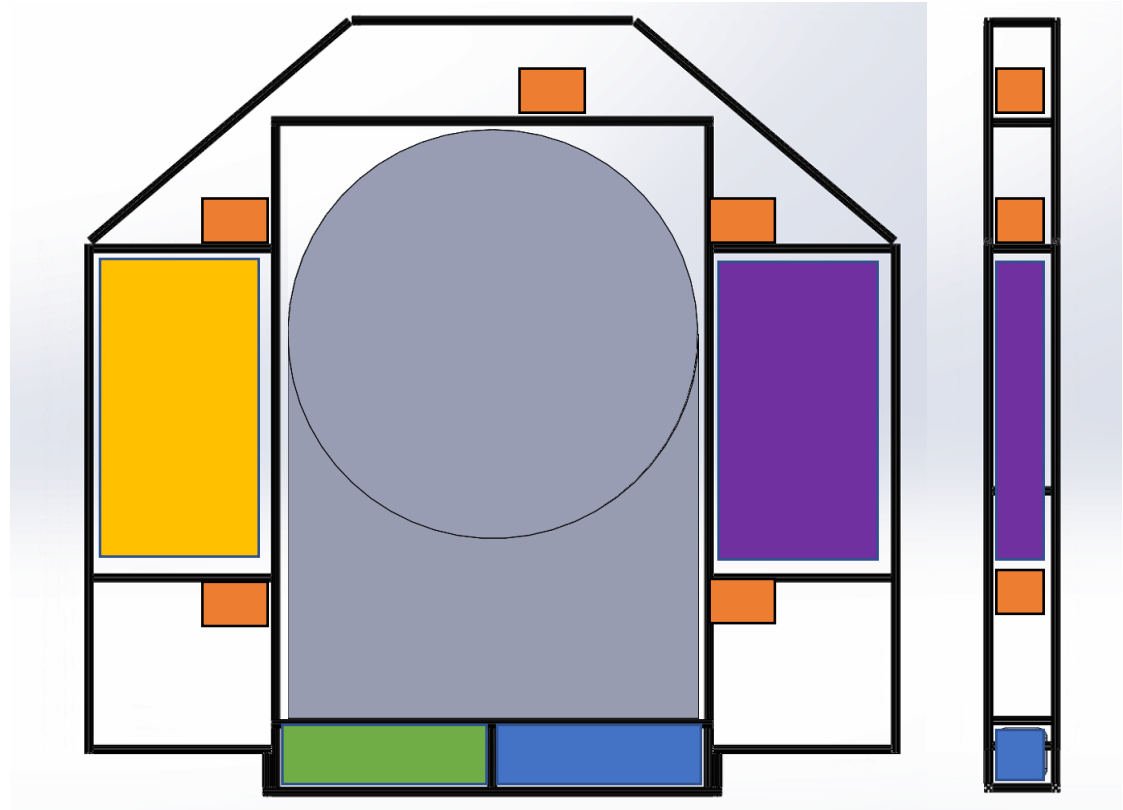
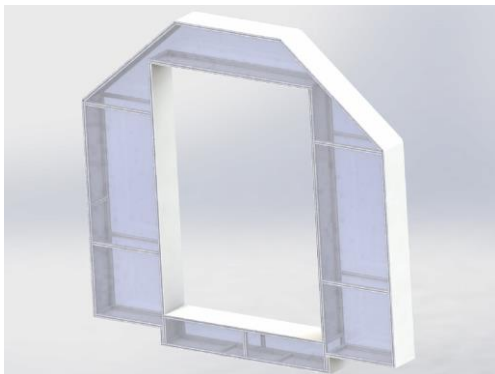



STARGATE Design Solution Ingress and Egress Method



- **Dutch Door styled hatch system**
- **Allows easy access as well as hatch simulation**

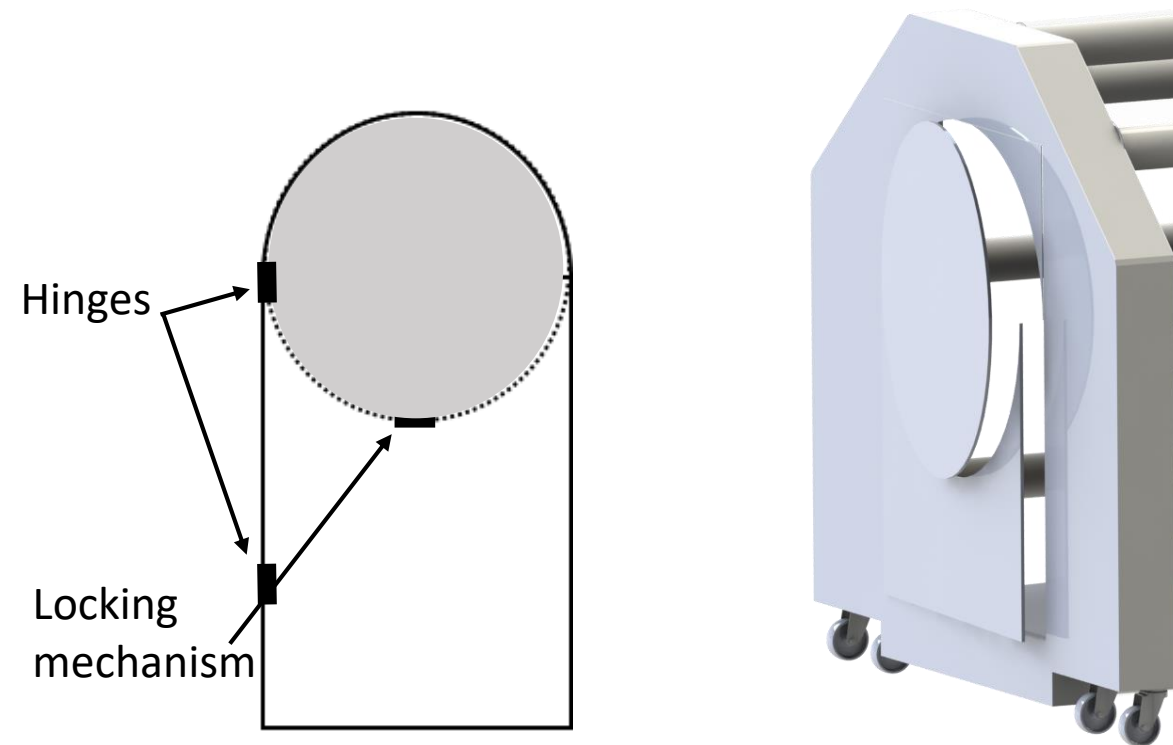



STARGATE Design Solution Radial Profile



- **6-in. Diameter air beams**

- Nonagonal configuration
- Inscribed on 8-foot diameter circle

- **Air beams Sizing**

- Provide expansion force during deployment
- Carry small internal loads (fabric hardpoints)

- **Semi-permanent outer wall**

- Removable using snap-button fastener system

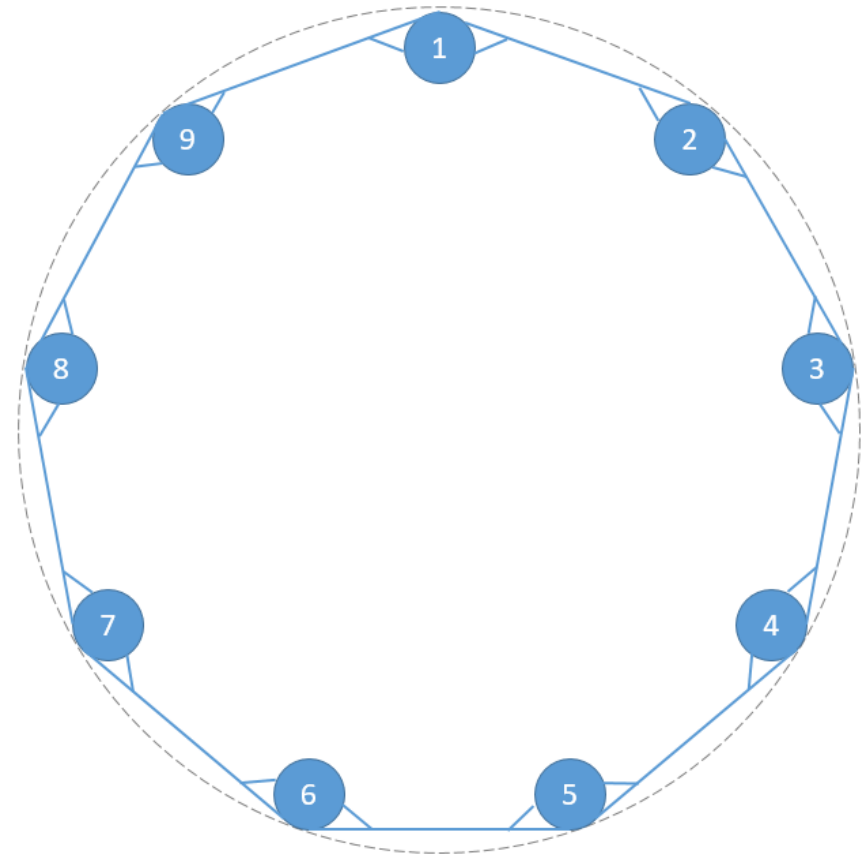

STARGATE Design Solution

Air beam Pneumatic Systems

- **Three Independent Pressure Lines**
 - Tubes alternate lines
 - Single line failure – symmetry maintained

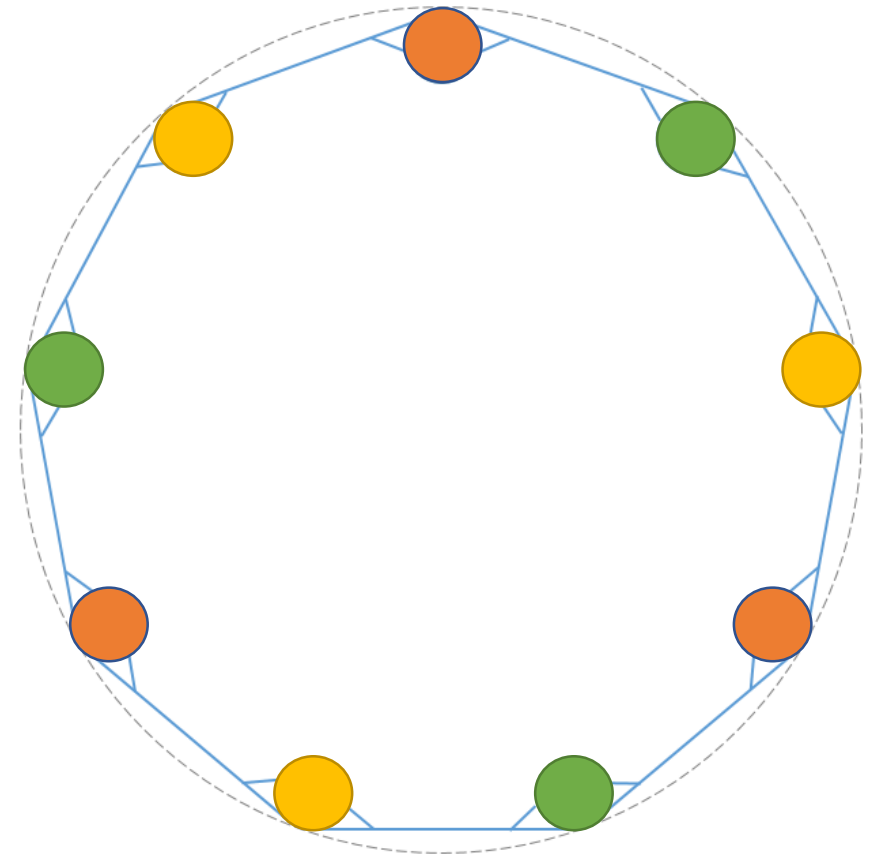
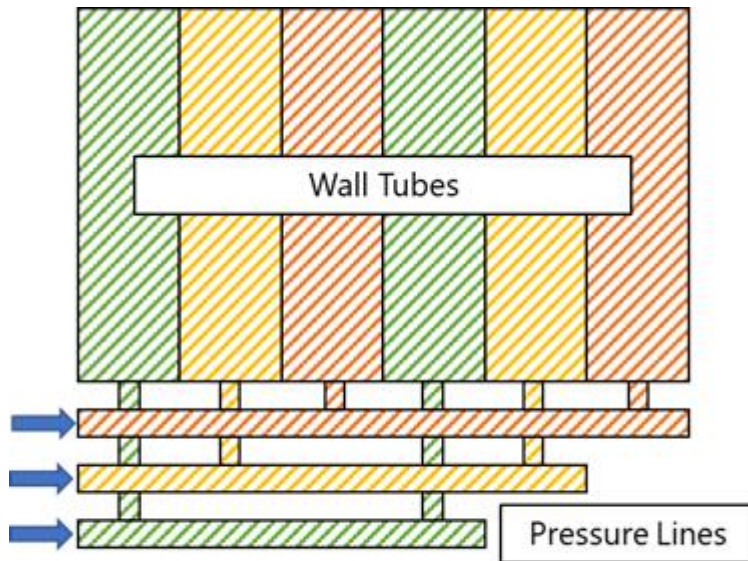

14 Dec 18



STARGATE Design Solution Air and Wall Manufacturing

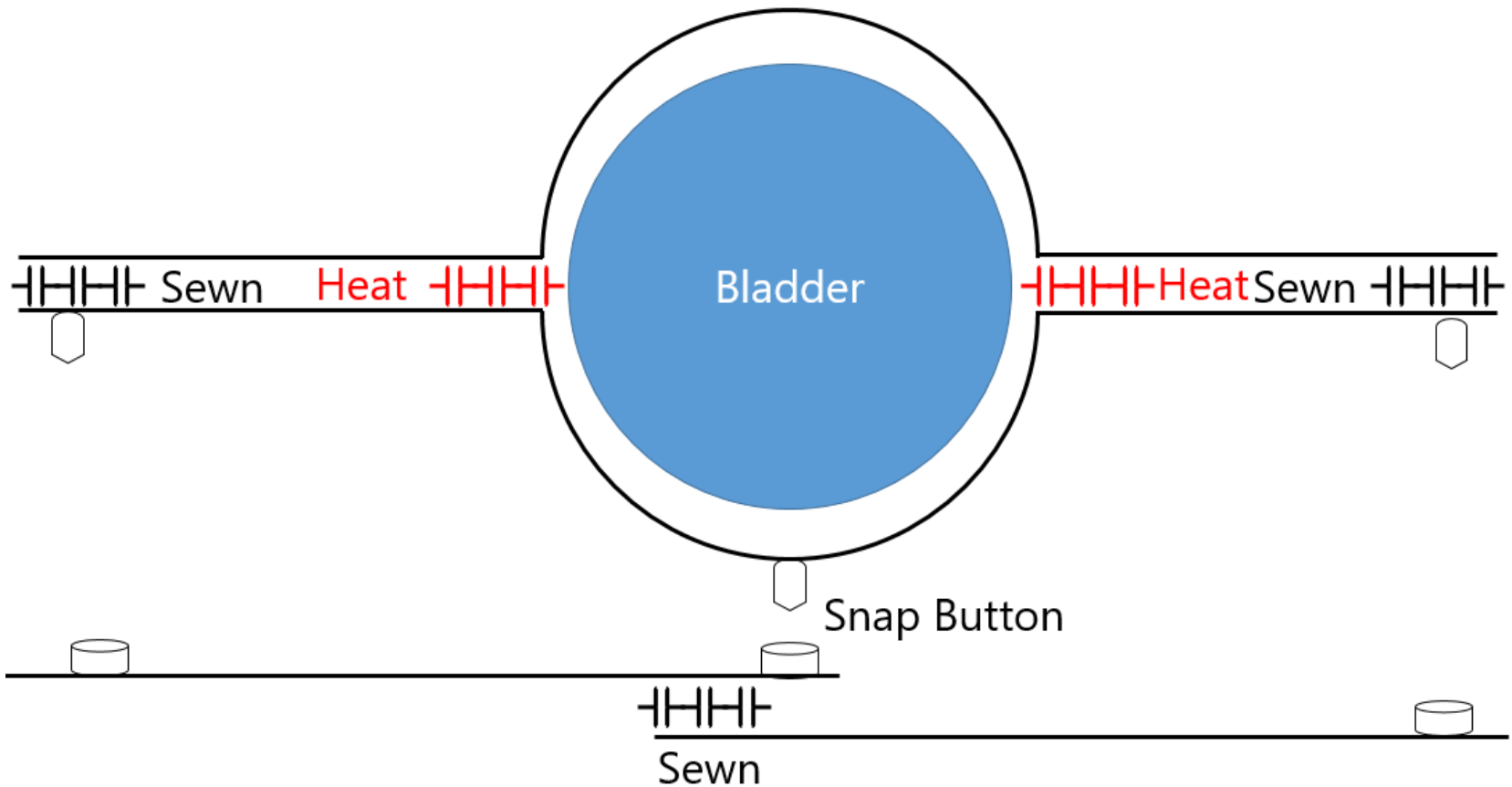



STARGATE Design Solution

Air beam & Wall Design



- **As-shipped interior configuration**

- Triangular channels on either side of each air-beam
- Housing space for electronics, lights

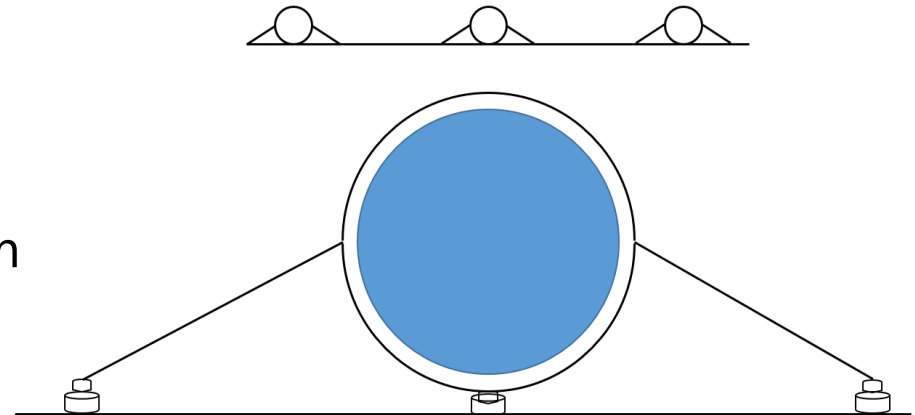

Configuration 1

Narrow channels for wires, lines, and lights

- **Optional interior wall**

- Attaches with snap-buttons
- Expands interior wall volume for integration of other systems (e.g. umbilical's)
- Variable level of flight fidelity

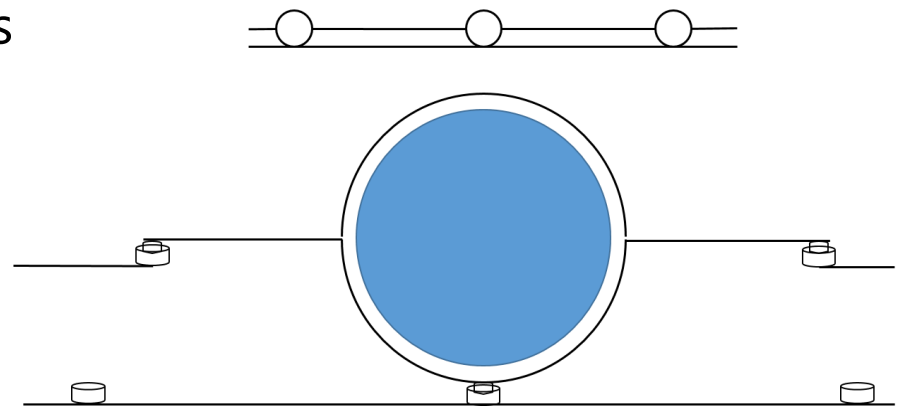

Configuration 2

More realistic "double wall," snaps in



STARGATE System Operations Ground Test Configurations



- **Four wall geometry configurations**
 - With and without a floor panel
 - With and without interior wall Panel
- **Easily configurable using "snap buttons"**

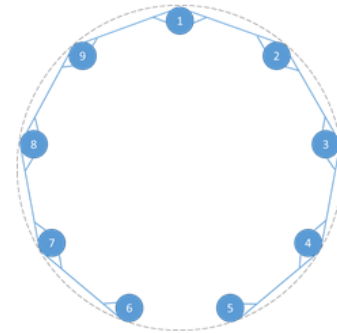

Single Wall, No Floor Panel

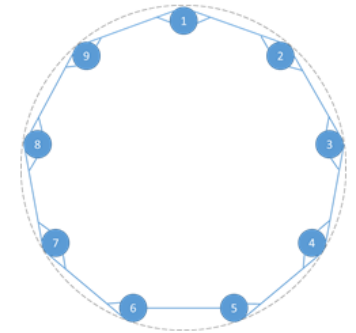

Single Wall, Floor Panel

Double Wall, No Floor Panel

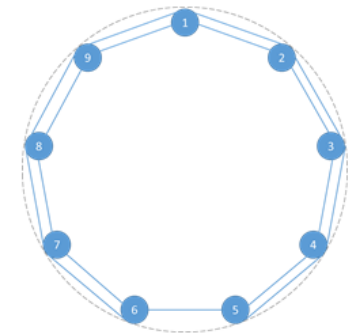
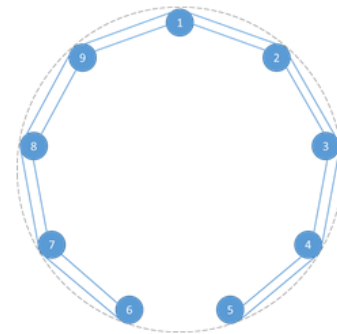

Double Wall, Floor Panel



STARGATE Design Solution Floor and Head Space



- **6' 5" of head space**
 - Designed to accommodate a standing suited astronaut
- **42" x 93" of floor space**
 - Designed to accommodate four crew members for demonstration with appropriate space

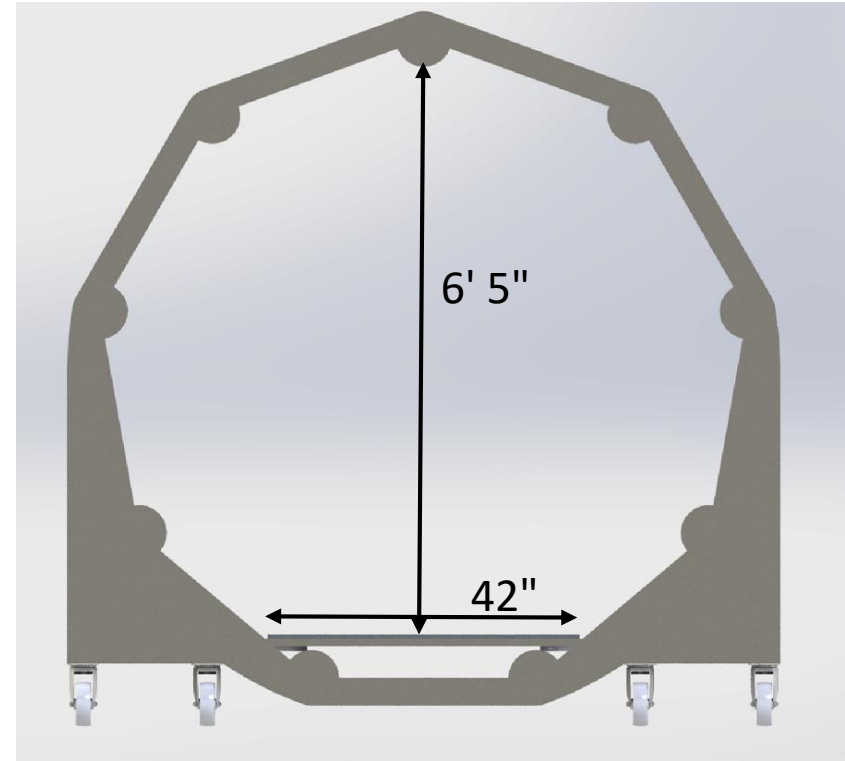



STARGATE Design Solution Floor Design



- **Floor folds in middle for improved collapsibility**
 - Simply supported by frame on sides

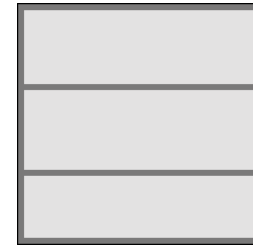

Catwalk Floor Segment

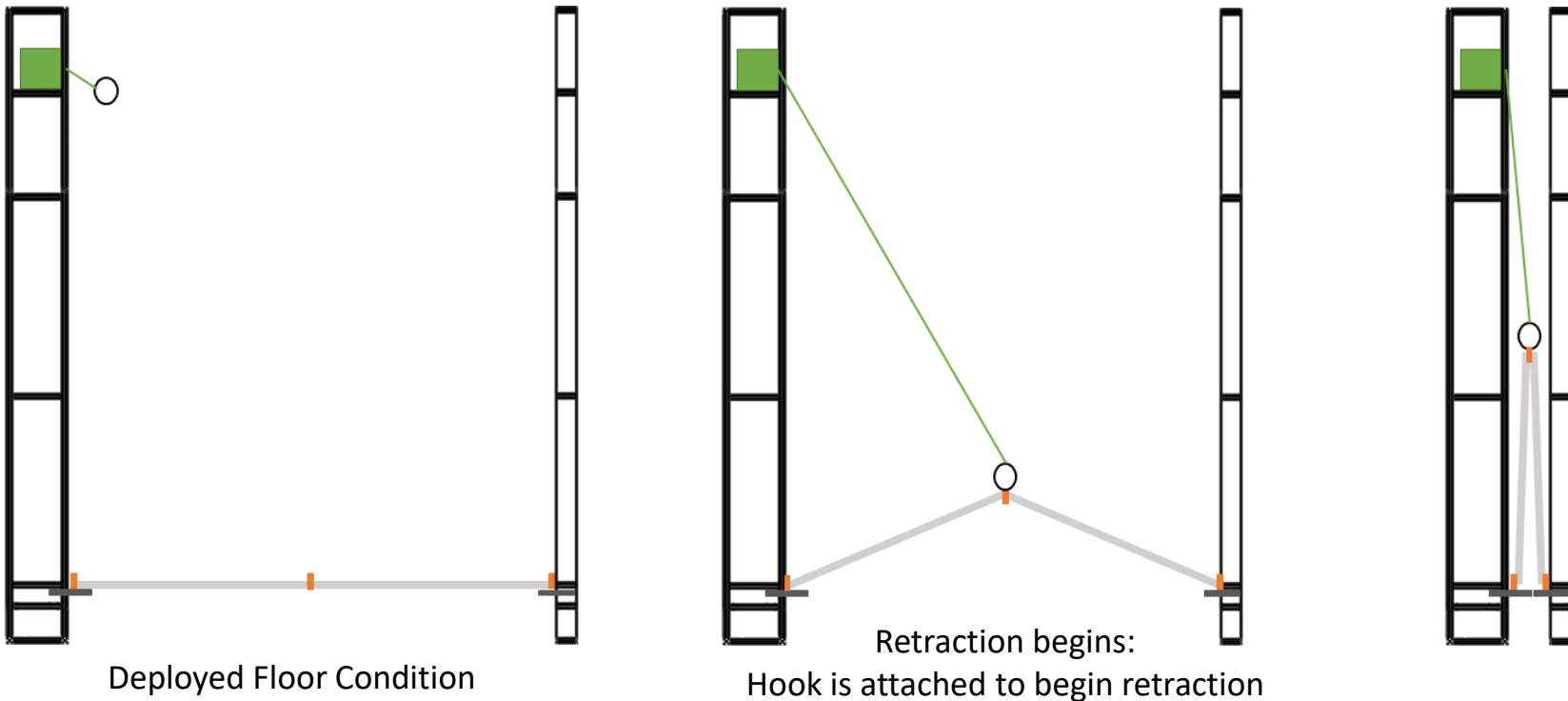



STARGATE Design Solution Bulkhead Frame



- **Same door assembly as Dock Frame**
 - Can either open standard size door or NASA size hatch
- **Same structural design as the Dock Frame**
 - Adequate room to mount any required systems
 - Lightweight for minimal-resistance deployment
- **Wheelbase can be increased for stability if needed**

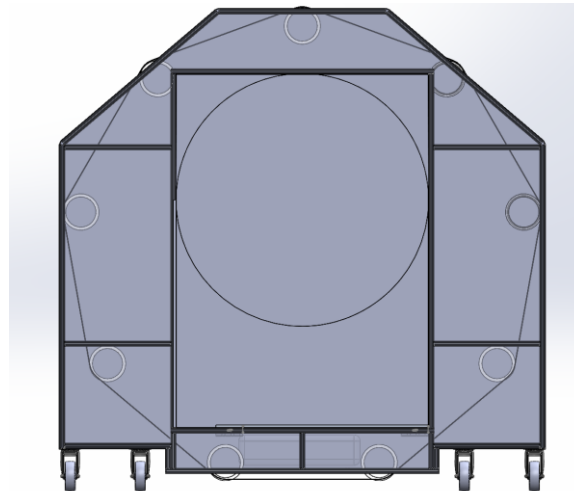



STARGATE Design Solution Hardpoints



- **Pair of collapsible metal beams**
 - Manually deployed after expansion
 - Folds flat against frame when stored
- **One set on each end**
 - Snap into place on opposite side
- **Allows for crewed operations in 1-g environment**
 - Support tool & equipment loads

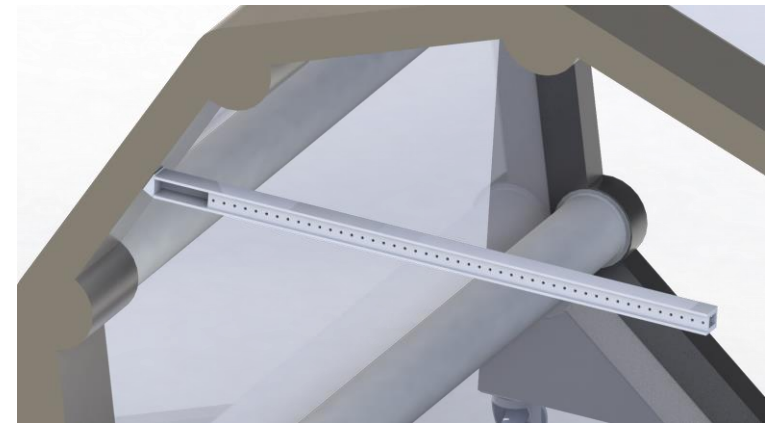
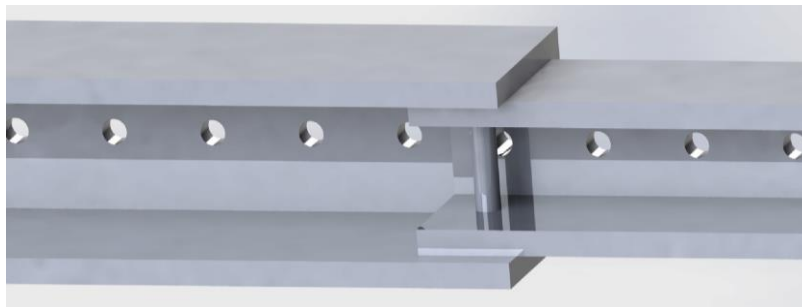
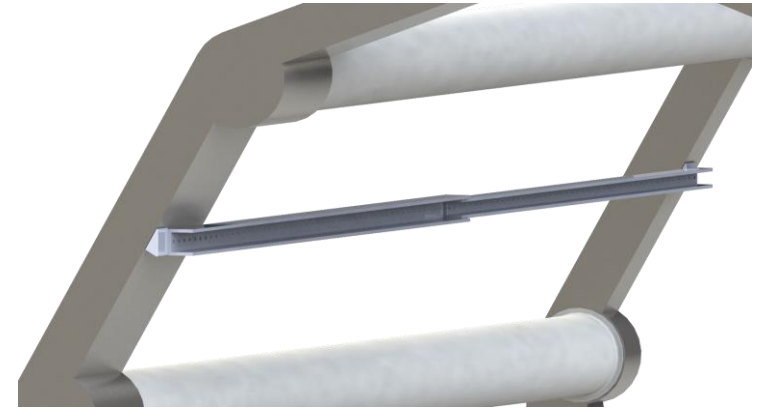



STARGATE System Operations Deployment Process



Stage 1

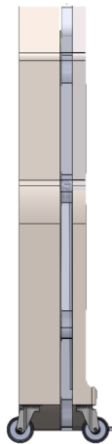

Stage 2

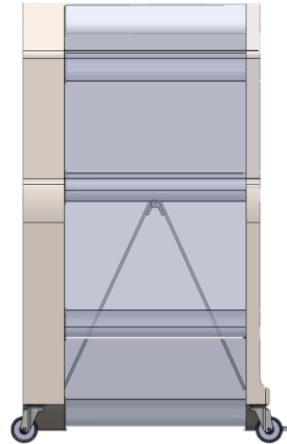

Stage 3

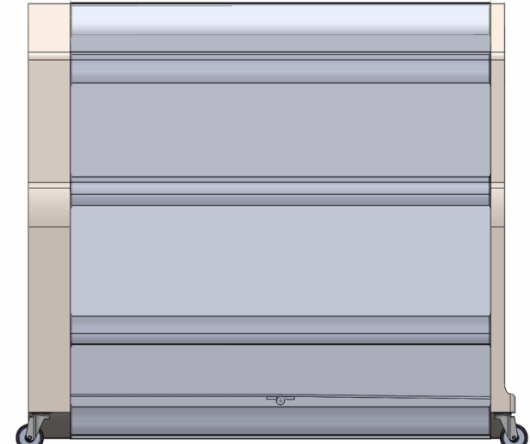

- Fully compacted
- Tube Pressure = 0 psi

- Partially expanded
- Floor begins unfolding
- $0 \text{ psi} < \text{Tube Pressure} < 0.5 \text{ psi}$
- Forward wheelbase in motion

- Fully expanded
- Floor fully expanded
- Tube Pressure = 0.5 psi
- Forward wheelbase stopped



STARGATE System Operations Retraction Method



- **Totally automated retraction**
 - Winches apply variable contracting force
 - Encoders on winch lines ensure even and consistent retraction
- **Microcontrollers interface with main control system**
- **Relief valves open on all lines**
 - Controlled slow release of air
 - Allows for even contracting & compacting

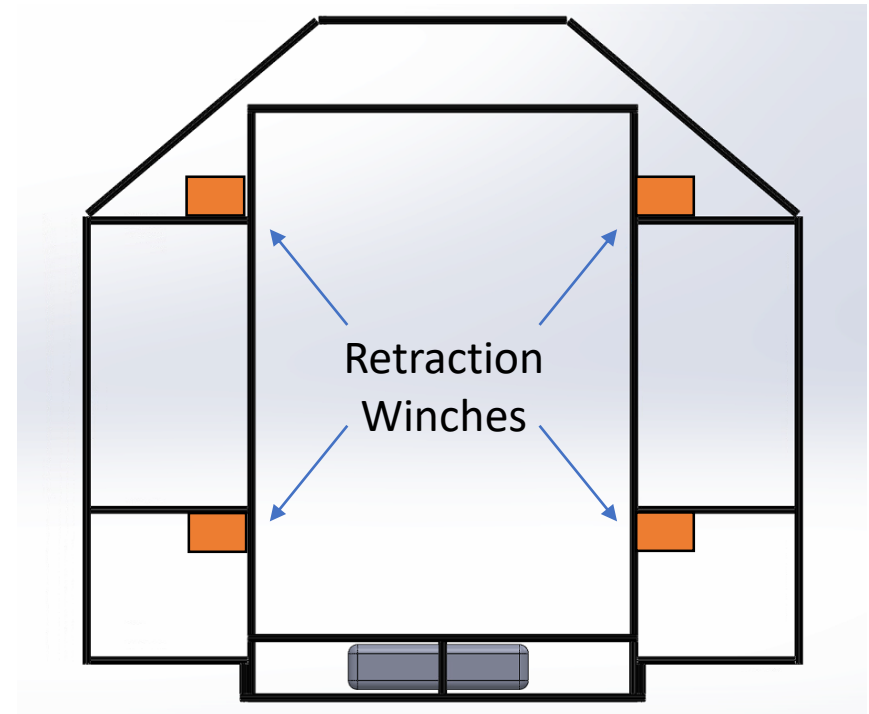



Research and Development



- **Model Development**
 - **System Analysis**
 - **Critical Load Analysis**
 - **Engineering Development Tests**
-

CDR POC: Madison Whiteley



Madison Whiteley



Hometown:

Coweta, Oklahoma

Major:

Aerospace & Mechanical
Engineering

Hobbies:

Reading

Lacrosse

Napping





Model Development Scale Model



- **Quarter scale model**
 - Foamboard, tape, and glue construction
 - Will model retraction methods and floor construction
- **Purpose**
 - Reference material for proportions of STARGATE
 - Display model for design and manufacturing space
 - Manufacturing space frequented by campus tours

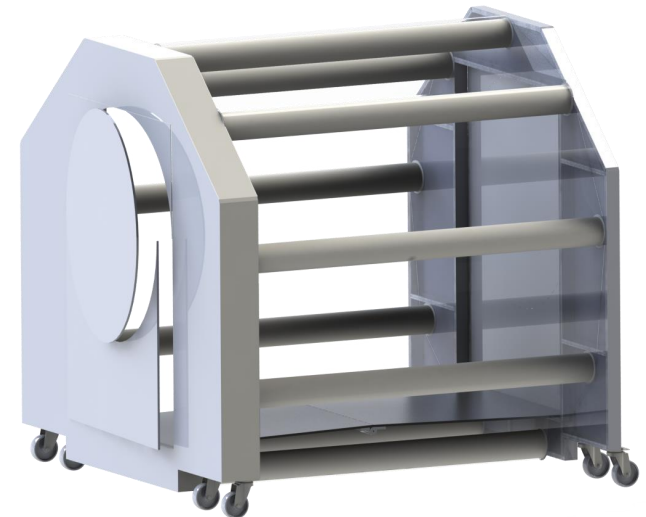



Model Development Virtual Reality



- **VR Model**
 - Using Autodesk software
- **Purpose**
 - Better understand physical proportions of STARGATE
 - Visualize scale model at 1:1 scale with no expense
 - Rapidly analyze impact of design changes on system configuration

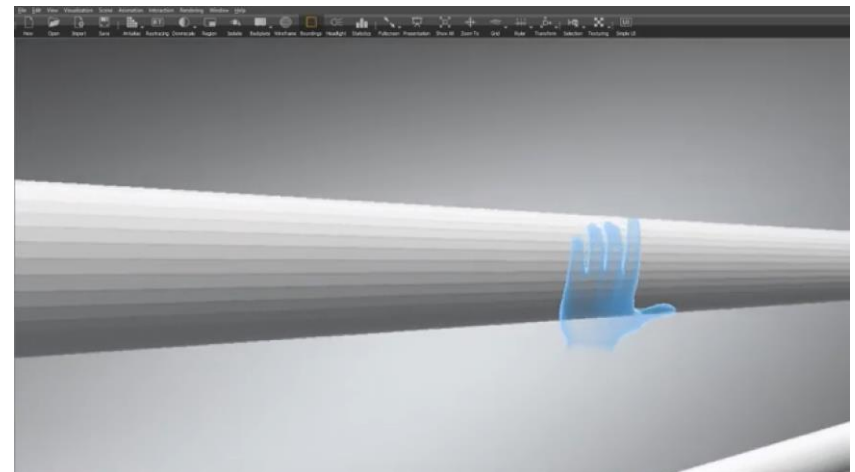
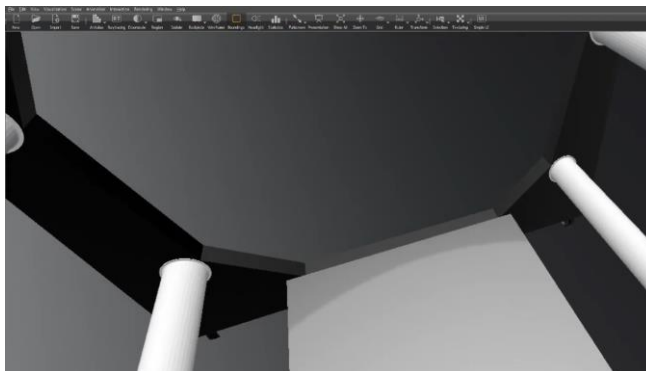



System Analysis Weight Estimation



- **Estimated Structural Weight**

- 720-lbs
- Includes both the Dock frame and bulkhead frame
- Determined from major structural dimensions

- **8020.net Structural Members**

- Estimated with 80mm x 40mm members
- 0.2317 lbs per inch

- **Factor of Safety of 1.5 applied to initial estimate**

- Accounting for fastener mass

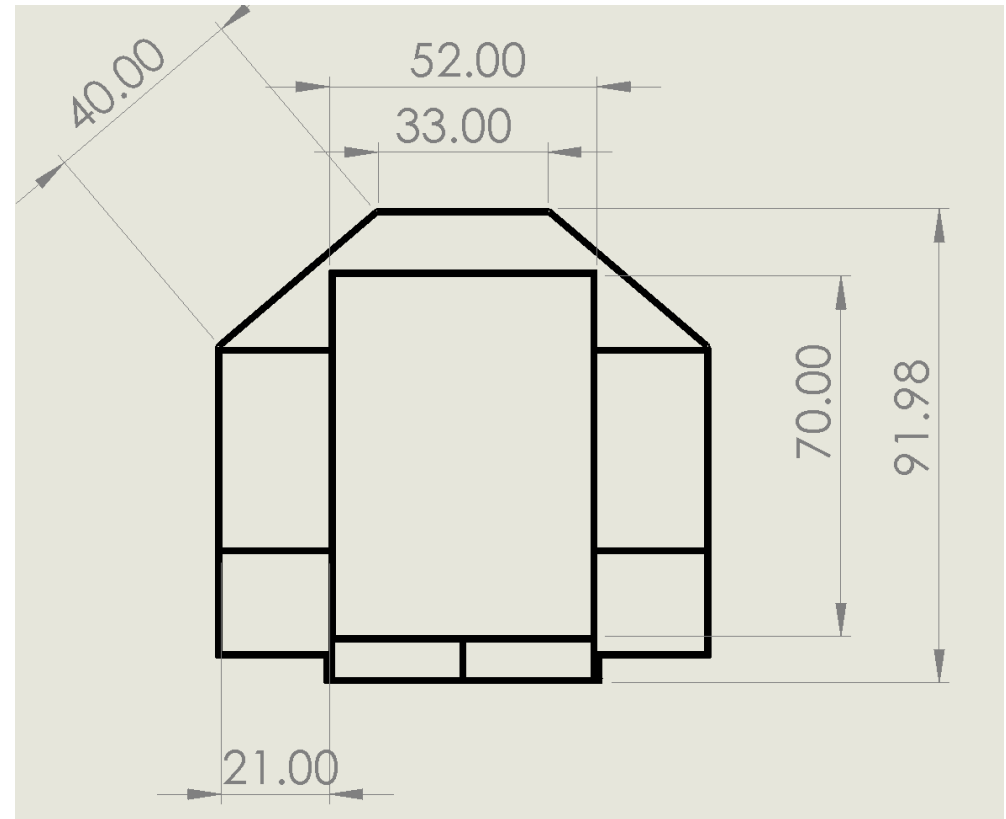



System Analysis Space Efficiency

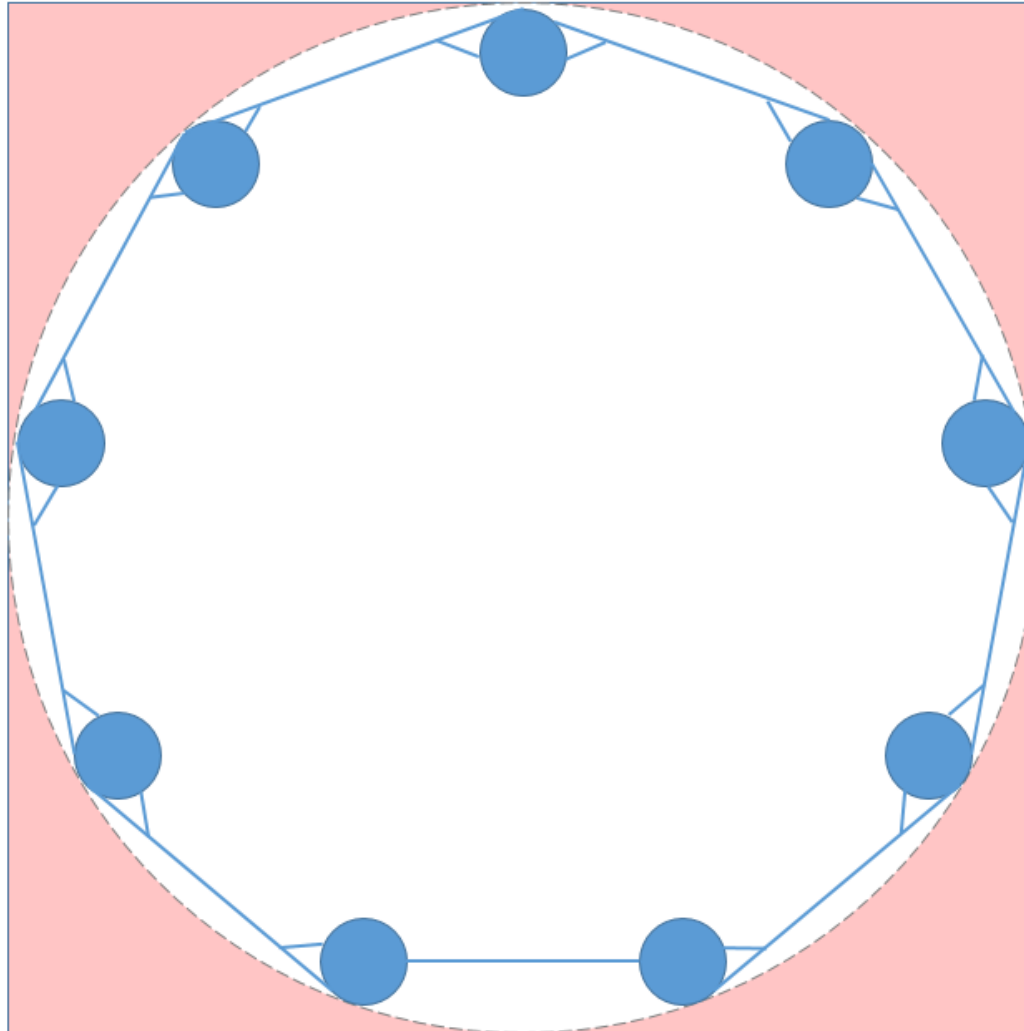

Typical Cross Section

Available Area

$64.00 - ft^2$

After Circularization

$50.27 - ft^2$

After Nonagonalization

$46.30 - ft^2$

After Air beam Incorporation

$44.50 - ft^2$

Volume Available

$512 - ft^3$

Interior Volume

$356 - ft^3$

Space Efficiency

69.5%



Floor Loading Analysis



▪ Critical load-bearing structure: hinge fastener

- Expected Failure Mode: Shear
- 14 fasteners per side to achieve 2.0 F.O.S.
- Can be increased w/ minimal weight penalty

▪ Bending Analysis

- Current floor design results in a F.O.S. of 4.96 at worst case

Frame

Floor Beams

Hinge

$$\Sigma M_o = Wl - Vh = 0$$

$$n\tau_{max} = V/NA$$

$$N = \frac{Wl}{h} / n\tau_{max}A$$

$$N = 13.99 \rightarrow N = 14 \text{ fasteners required}$$

W = 1000-lbf	Maximum Weight
l = 42-in	Span Distance
h = 40-mm	beam height
A = 0.019-in ²	Fastener Area design F.O.S.
n = 2.0	Steel S _{sy}
τ _{max} = 50-ksi	

Frame

Floor Beams

Hinge

$$M_o = Wl$$

$$\sigma_{max} = Mh/Nl$$

$$\sigma_{max} = Wlh/Nl$$

$$\sigma_{max} = 7027 \text{ psi}$$

$$n = S_y/\sigma_{max} \rightarrow n = 4.96$$

W = 1000-lbf	Maximum Weight
l = 42-in	Span Distance
h = 40-mm	beam height
I = 2.346-in ⁴	Fastener Area design F.O.S.
n = 2.0	Number of 8020 Beams
N = 4	6061-T5 Aluminum
S _y = 34.9-ksi	



Validation & Experimentation



- **Senior Aerospace Courses require capstone related experimentation**
 - Use required experimentation to develop safety documentation for air beam systems
 - Final reports and data will be incorporated into final delivery user guide

 - **Major Validation Areas**
 - Airbeam Construction Methods
 - Air Beam Burst Test – expected failure mode of air beams
 - Air Beam Bending Test – maximum point and distributed load
 - Pressure Lift Test – maximum load displaced by an expanding pressurized volume
 - Pressure Push Test – horizontal displacement of mass and transient pressures
-

Validation & Experimentation Air Beam Construction Methods

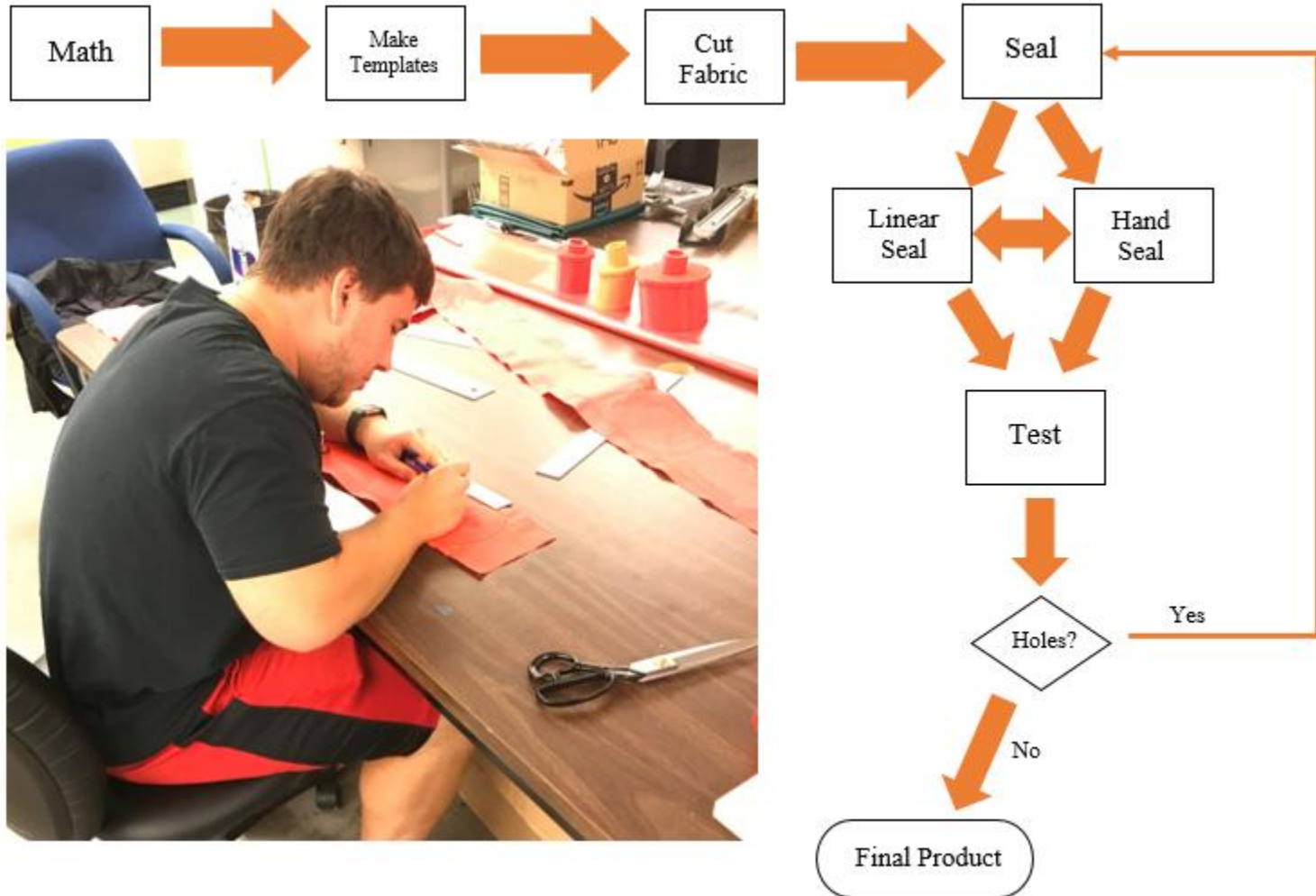



Validation & Experimentation Air Beam Burst Test



▪ **Objective:**

- Verify strength of beam-bladder system
- Ensure worker safety

▪ **Process:**

- Beams with bladders will be inflated until either the bladder or fabric encasing the bladder bursts.
- Will test to ensure beams will not burst at high pressure or through multiple uses.

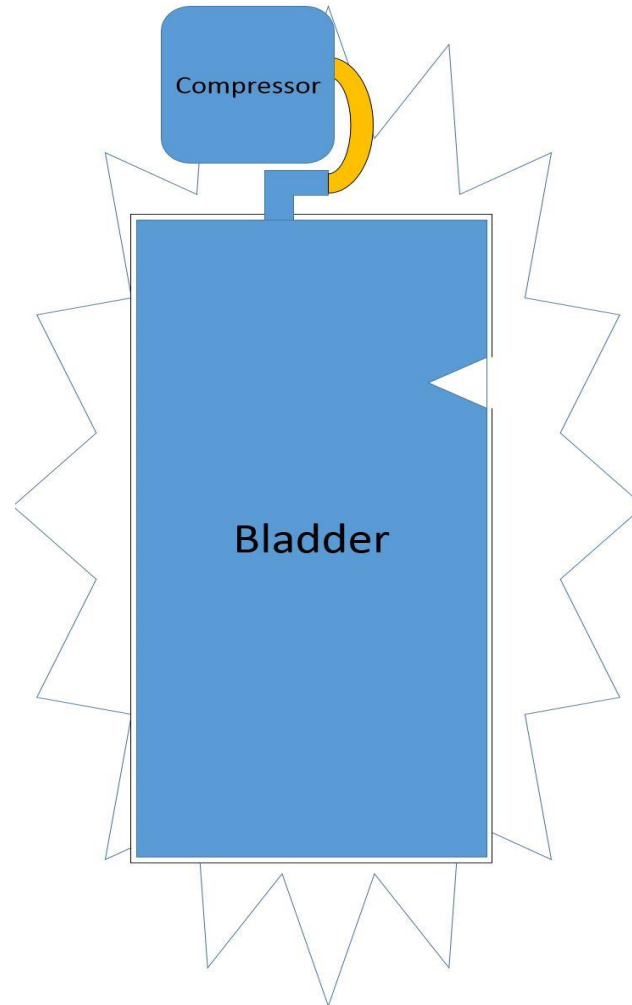

Validation & Experimentation Air beam Bending Test

- **Objective:**

- Determine accurate buckling resistance of large-diameter, low-pressure for proposed materials and manufacturing techniques

- **Test Rig:**

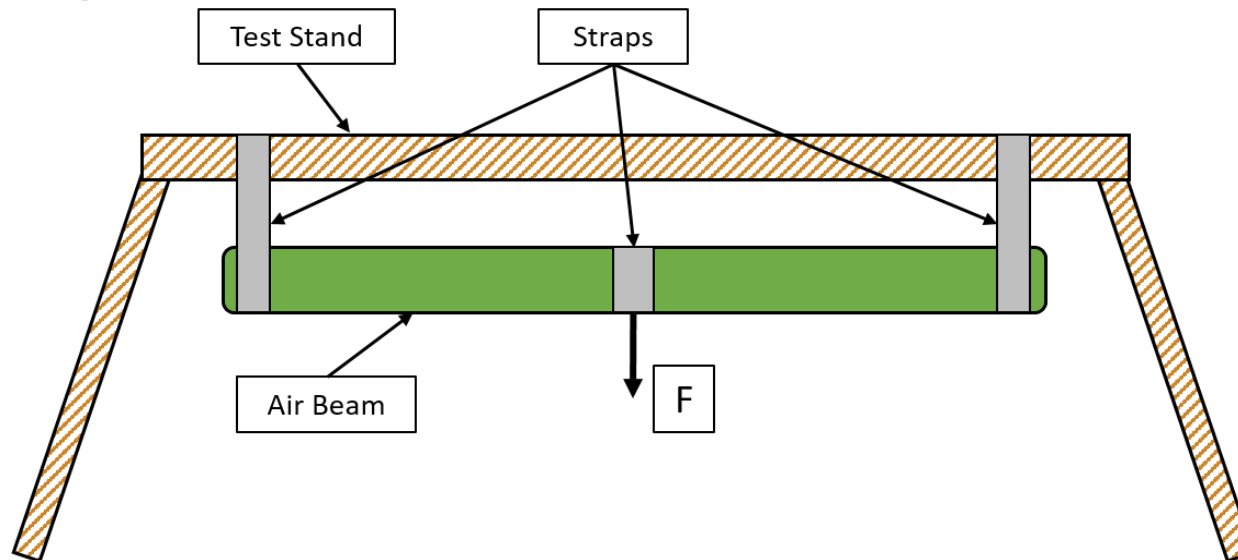



Validation & Experimentation Pressure Lift Test



▪ Objective:

- Determine maximum opposing force that air-beams can overcome during deployment

▪ Process:

- With the exterior design on its side, weight is added to upper surface to measure the vertical deployment force at 0.5psig.

▪ Test Rig:

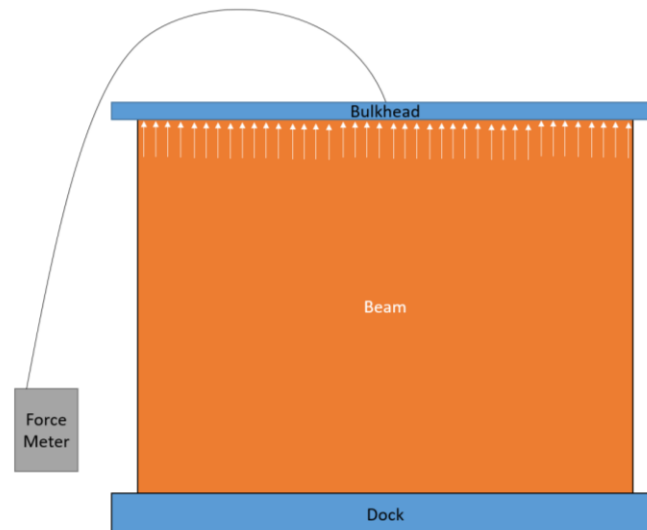



Validation & Experimentation Preliminary Push Test



▪ **Objective:**

- Determine the maximum weight which can be pushed on rollers during tube expansion

▪ **Results:**

- 170 lb. weight which could be pushed
- Expansion force = 5.5 lbf
- Force varies on tube contraction method

▪ **Test Rig:**

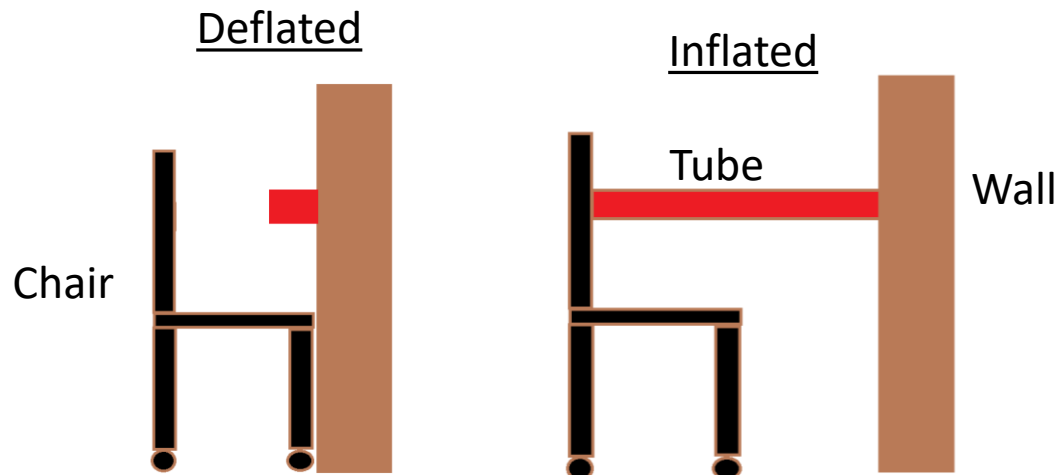



System Operations and Interfacing



- **Engineering Specialty Plans**
 - **Wiring Schematic**
 - **Pneumatic System Diagram**
 - **Control Methods**
 - **Facilities Tour**
-

CDR POC: Josh Pankratz



Josh Pankratz



Home Town:

Hydro, Oklahoma

Major:

Aerospace and Mechanical
Engineering

Hobbies:

Reading

Trail Riding

Video Games





Engineering Specialty Plan

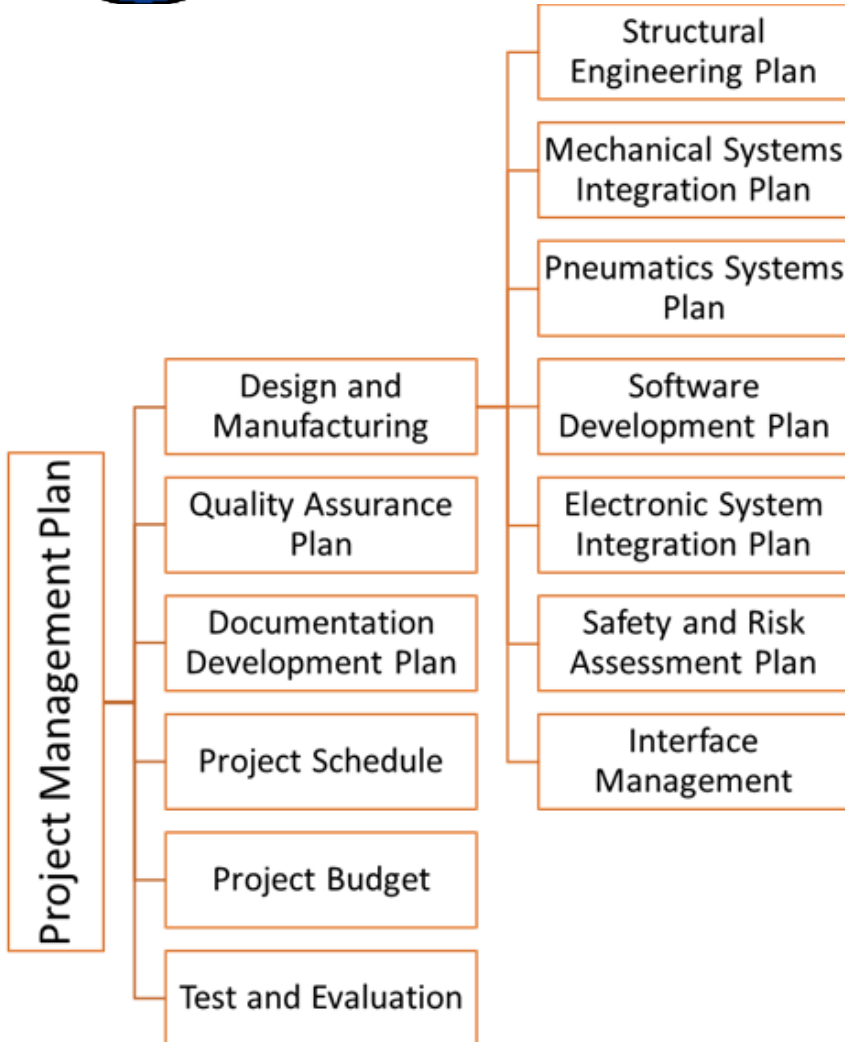

▪ **Broad Categories**

- Project separated into six broad categories areas for planning
- Broad categories monitored weekly at university level
- Effort to communicate bi-weekly

▪ **Design and Manufacturing Specialties**

- Seven critical areas identified
- Each will have an appointed Subject Matter Expert (SME)
- SME will monitor all progress in critical area, and will update management regularly

▪ **More Detail in Backup Slides**



Basic Wiring Schematic

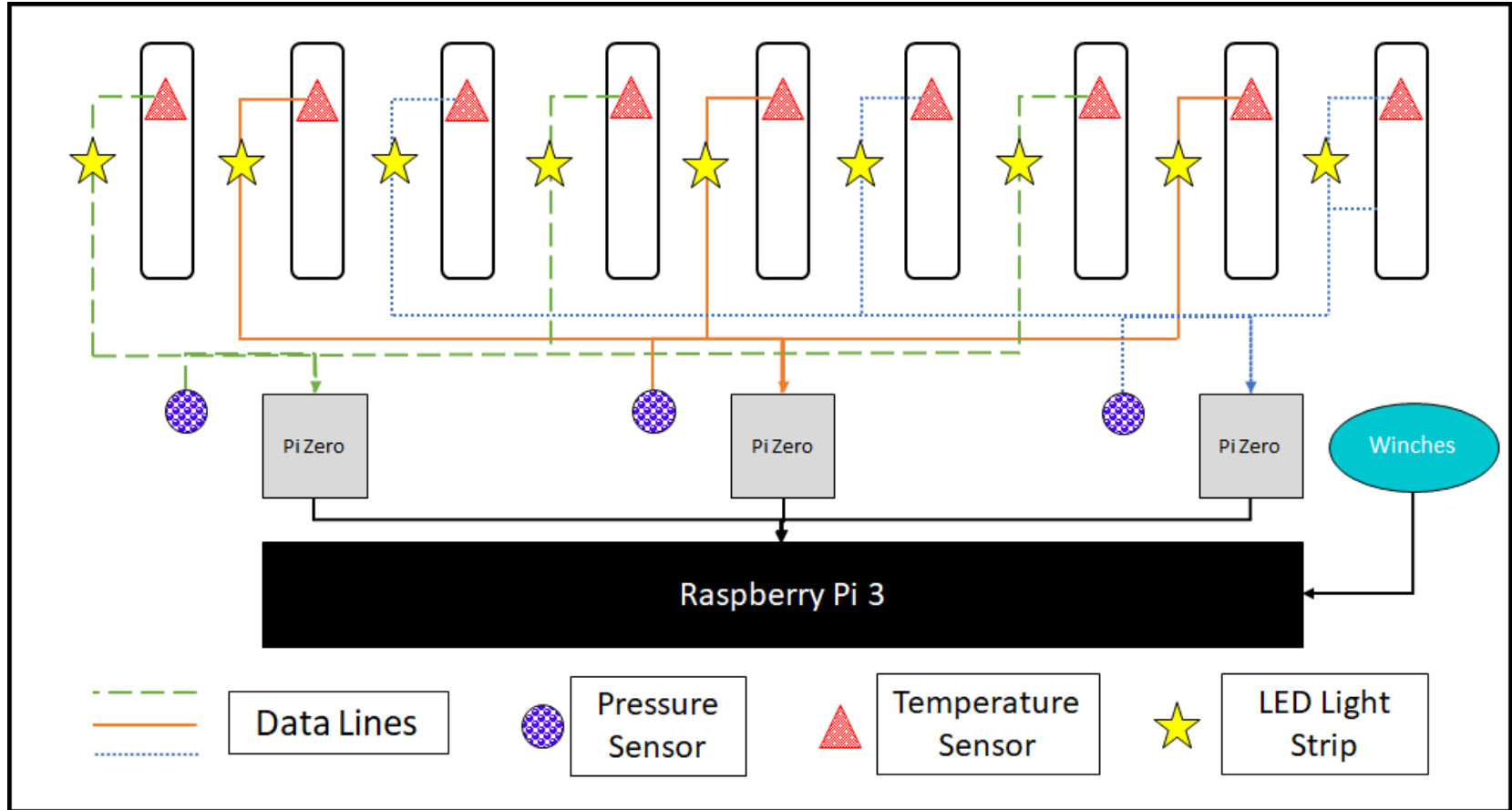



Pneumatic System Diagram

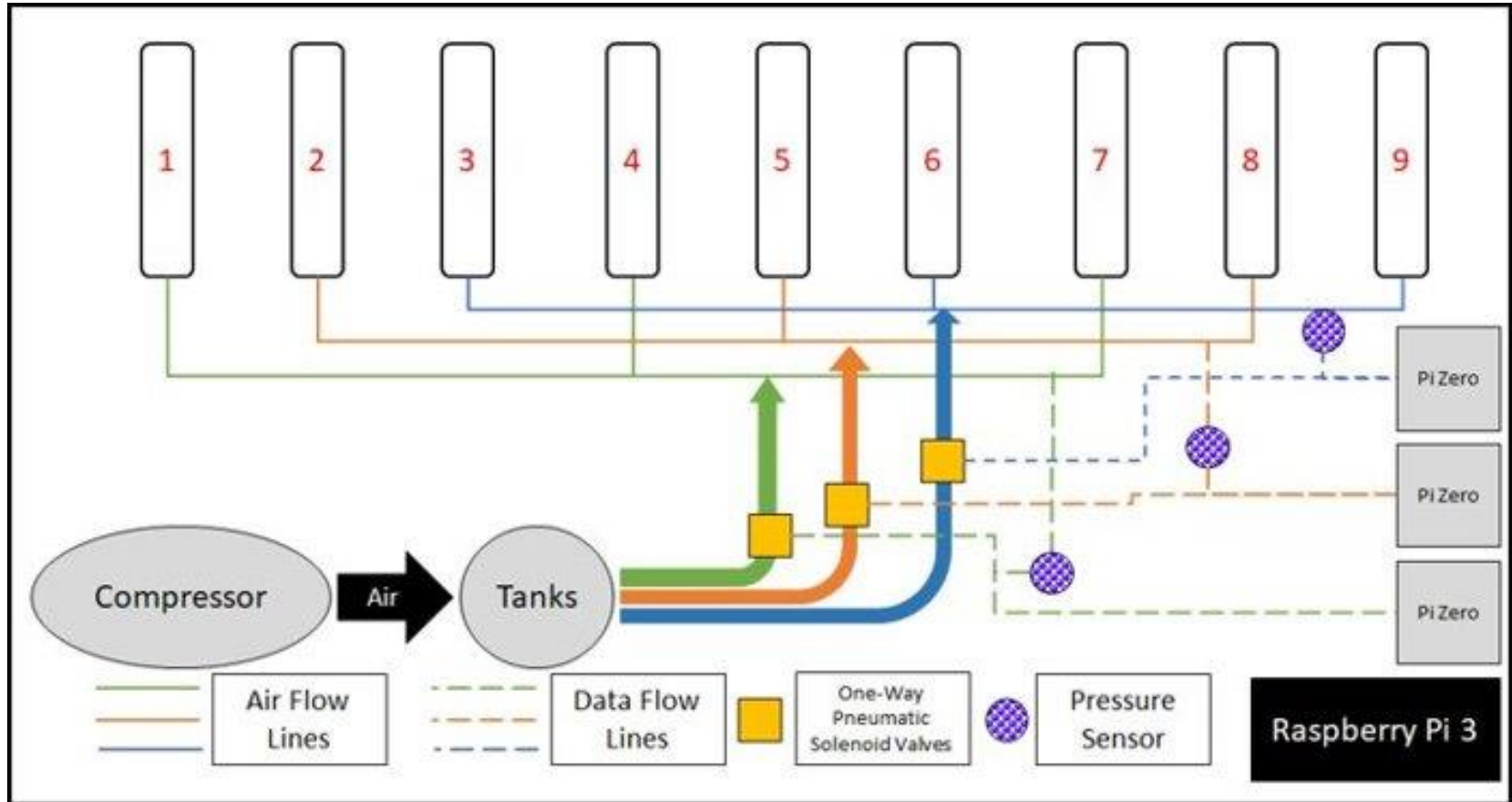



Control Methods



Current Board:

Raspberry Pi Zero

Alternative Board:

MyRio from National Instruments

Reasons:

Field programmable gate arrays (FPGA)

- Allows for fast I/O response
- Fast prototyping
- Logic control is run on hard circuits
- Industry level control setup that is reprogrammable

Labview:

- Direct interface with FPGA
- Easy to use graphical programming

Primary Control Panel
& Data Readout

Power

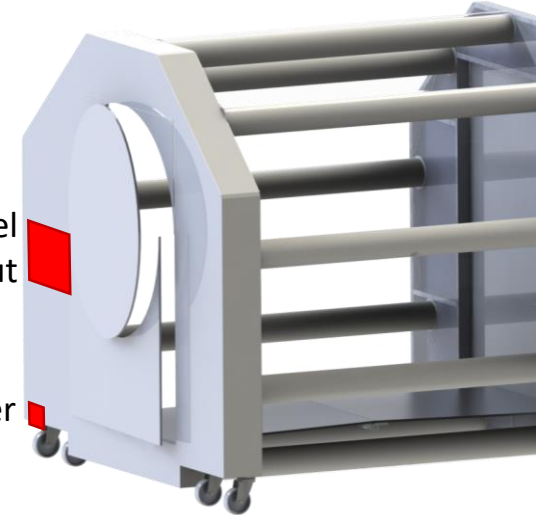



Facilities Tour Primary Workspace

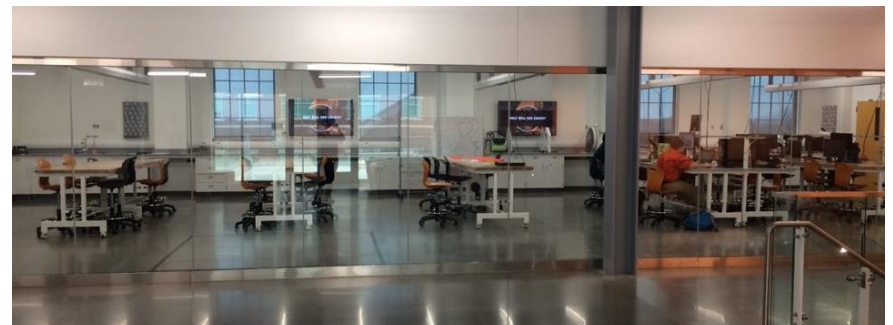
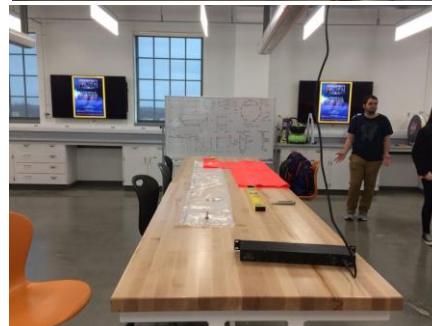
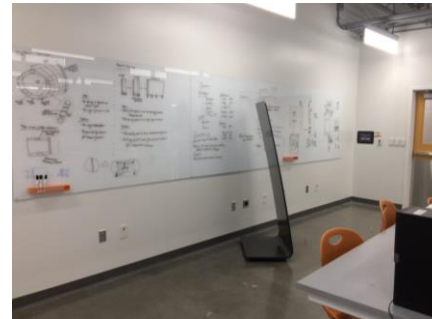
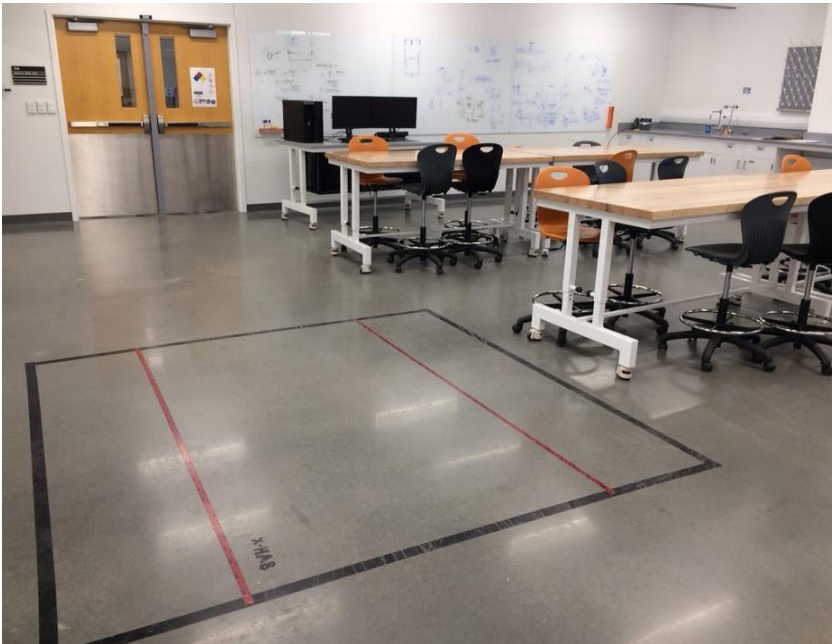



Facilities Tour Other Workspaces



- **Primary Workspace**

- Eight dedicated computer workstations
- 1800 – sq. Ft.

- **Adjacent Workspaces**

- Electronics Maker Space (attached room)
- Plastic/Nylon Additive Manufacturing Room (two floors down)

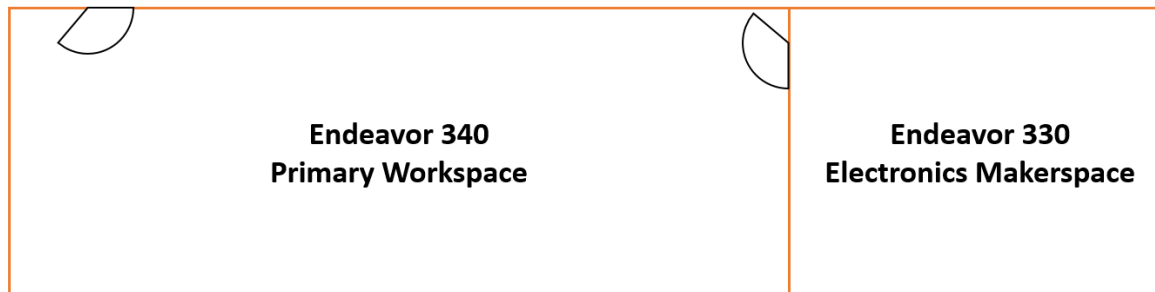
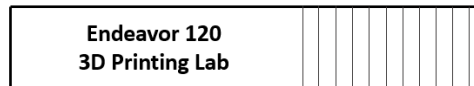



Administrative Review



- **Hazard Matrix**
 - **Risk Management**
 - **FOD Avoidance**
 - **Budgeting Data**
 - **Post-CDR Schedule**
-

CDR POC: Michael Raymer



Michael Raymer



Hometown:

Broken Arrow, Oklahoma

Major:

Aerospace &
Mechanical Engineering

Hobbies:

Flying

Hiking

Aircraft Ferry

Auto & Aircraft Maintenance

Competitive Shooting

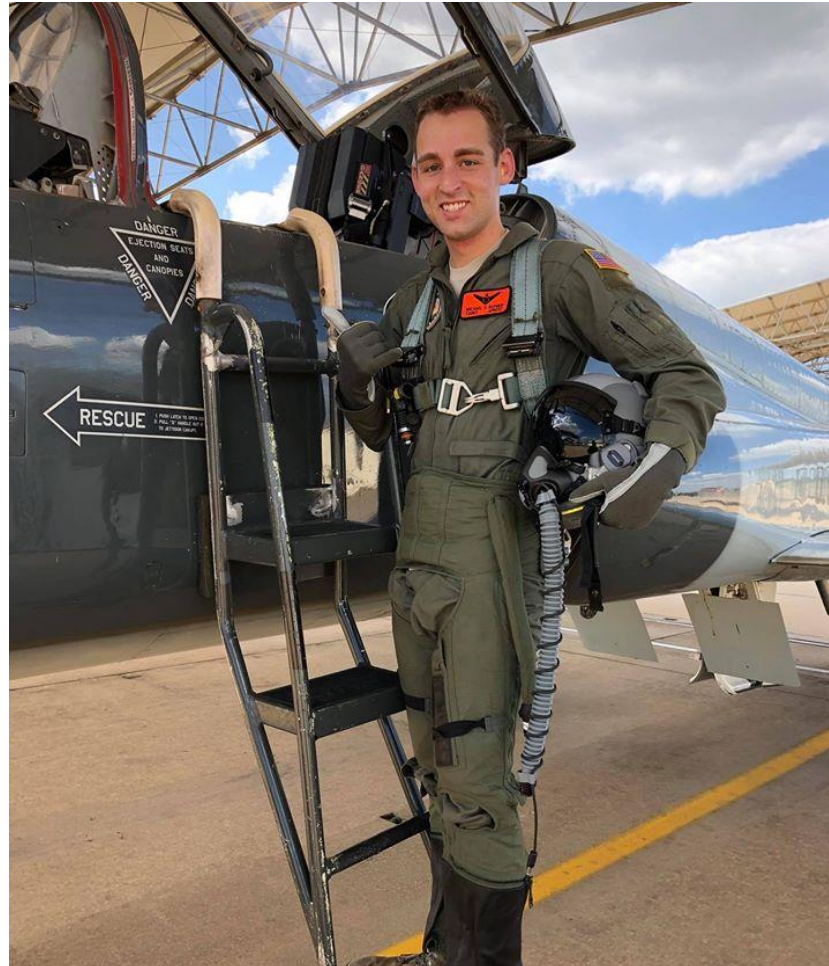



Hazard Matrix



P= Risk to Personnel A= Risk to Assets	Probability [Pr] Estimations				
	A: Frequent	B: Probable	C: Occasional	D: Remote	E: Improbable
Severity Classifications					
I: Catastrophic					P07
II: Critical					A02, P02, A07
III: Moderate				A04	P04
IV: Negligible			P05, P09	P06, A08	A01, P01, P03

Hazard Code	Hazard Description
01	Electrocution
02	Fire
03	CO2
04	Structural Failure
05	Minor Injury
06	Thermal
07	Compressor Explosion
08	Pressure Lines
09	Entering Confined Spaces

RAC: 1	Unacceptable – All operations shall cease immediately until the hazard is corrected, or until temporary controls are in place and permanent controls are in work.
RAC: 2	Undesirable – All operations shall cease immediately until the hazard is corrected or until temporary controls are in place and permanent controls are in work.
RAC: 3	Acceptable with controls – Division Chief or equivalent management is authorized to accept the risk with adequate justification.
RAC: 4-7	Acceptable with controls – Branch Chief or equivalent management is authorized to accept the risk with adequate justification

More Detail in Backup Slides



JPR 1700 Regulations



Detailed review pending access to checklist provided by NASA contact

- 6.3.4: Warehouse Safety and Health
- 6.7: JSC's Policy for handling Unique Hardware or Materials
- 6.9: Space Systems and Test Safety
- 6.10: Confined Spaces
- 6.11: Pressurized Gas

Regulation	Applicability	Status
6.1	N/A	
6.2	N/A	
6.3	Applies	Reviewed
6.4	N/A	
6.5	N/A	
6.6	N/A	
6.7	Applies	Reviewed
6.8	N/A	
6.9	Applies	Reviewed
6.1	Applies	Reviewed
6.11	Applies	Reviewed
6.12	N/A	
6.13	N/A	



FOD Avoidance



- **Design Consideration for FOD prevention**
 - Systems and hardware will be enclosed for the duration of the analogue deployment and retraction.
 - Removeable panels will be implemented for ease of access for inspection and cleaning in FOD control areas
 - FOD critical areas are sealed off to prevent debris and water from entering and damaging crew-lock
 - Open floor scheme prevents FOD entrapment within crew-lock

 - **FOD Area Classification**
 - FOD Critical Areas: Inflatable air-beams
 - FOD Control Areas: Electronics and hardware housed within airlock within removable panels, hardpoints, bulkhead frames
 - FOD Awareness Areas: Inner crew lock area, crew-lock walkway
-



Cost and Schedule Data Itemized Budget for Materials



▪ **Fabrics**

- Based on cost-per-yard from manufacturer
- Allowance for F.O.S. of 1.5

▪ **Structural Hardware**

- Cost values sourced from 8020.net
- "Finishing" category includes cost of exterior paneling, floors, etc.

▪ **Electronics**

- Subject to change in-lieu of contact with National Instruments

Area/Item	Subtotal	Itemized
Fabrics	\$ 950.00	
Bladders		\$ 60.00
Air beam Walls		\$ 450.00
Demonstrator Wall Panels		\$ 320.00
Allotment for Cost Overrun		\$ 120.00
Structural Hardware (8020.net estimate)	\$ 3500.00	
Catwalk Construction		\$ 660.00
Catwalk Finishing		\$ 100.00
Dock and Bulkhead Frames		\$ 2000.00
Dock and Bulkhead Finishing		\$ 300.00
Allotment for Cost Overrun		\$ 440.00
Electronics	\$ 1050.00	
Control Systems (Raspberry Pi)		\$ 50.00
Air beam Control Sensors		\$ 315.00
Pneumatic Systems		\$ 300.00
Crewed Volume Sensors & Lighting		\$ 250.00
Allotment for Cost Overrun		\$ 135.00
Total	\$ 5500.00	



Cost and Schedule Data Overall Budget



▪ JSC Delivery Estimate

- 550-mi. U-Haul rental (one way)
- Two vehicles for student and faculty travel
- Two nights in Houston/JSC area

▪ Current estimate for unallotted budget

- \$1800.00
- Used for large unexpected cost overruns
- Development of extra functions, tools, and features

Area/Item	Subtotal	Itemized
Demonstration Article	\$ 5500.00	
Fabrics		\$ 950.00
Structural Hardware		\$ 3500.00
Electronics		\$ 1050.00
JSC Delivery Estimate	\$ 2700.00	
Vehicle Rental (U-Haul Est.)		\$ 293.00
Gas (1 vehicle at 12-mpg, 2 at 18-mpg)		\$ 535.00
Lodging		\$ 1400.00
Allotment for Cost Overrun		\$ 472.00
Estimated Remaining Budget	\$ 10000.00	
Unallotted Budget	\$ 1800.00	



Post-CDR Schedule Timeline

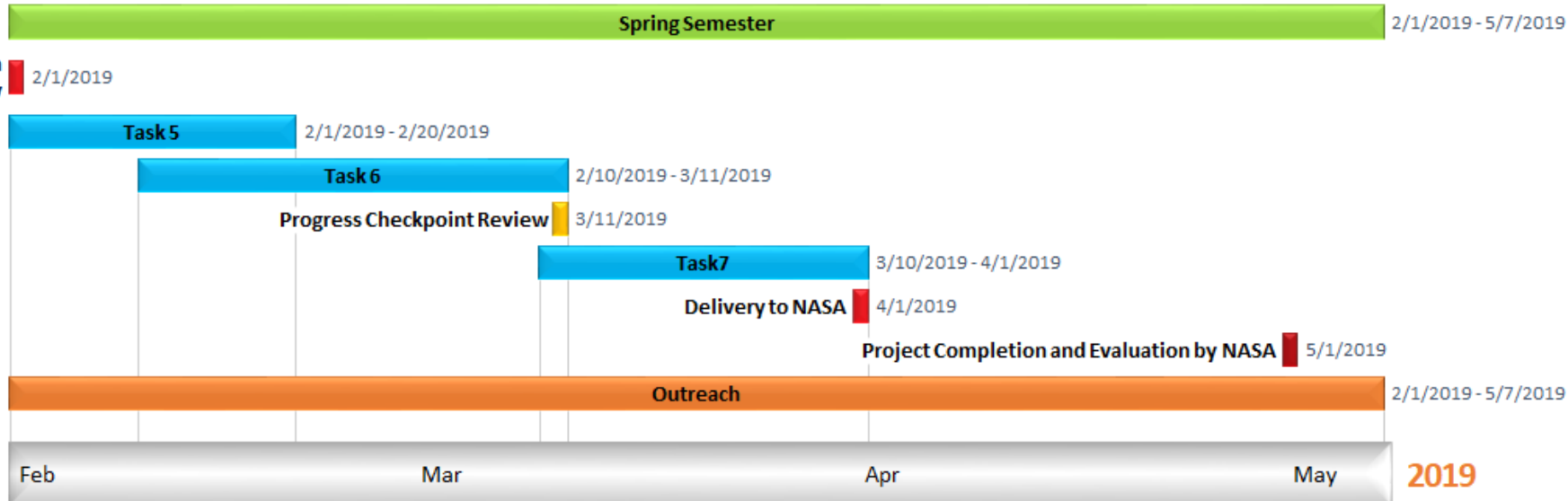

- **Task 5**
 - *Final Engineering Model Construction*
- **Task 6**
 - *Testing, Technology Maturation and Implementation*
- **Task 7**
 - *Documentation Development, Validation, Delivery*



Post-CDR Schedule Outreach



- **Potential Outreach**
 - Stillwater Public Schools
 - Public Schools in surrounding counties
- **Outreach topics**
 - Perspective as STEM students
 - Use of inflatable structures
 - Future of inflatables in
 - Space Applications
- **Outreach Tools**
 - VR models
 - Scale Models
 - Inflatables

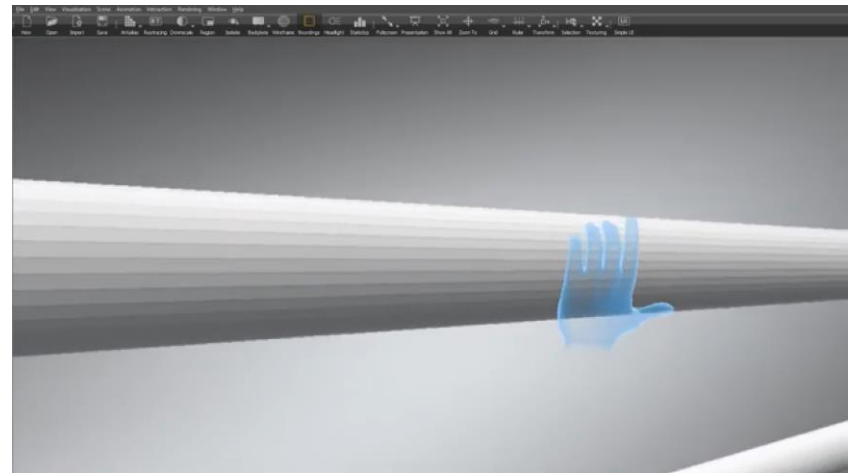



Review & Questions



- **Administrative Overview**
 - CDR POC: Justin Duewall
 - **Analog System Design Solution**
 - CDR POC: Austin Bennett
 - **Research and Development**
 - CDR POC: Madison Whiteley
 - **System Operations and Interfacing**
 - CDR POC: Josh Pankratz
 - **Administrative Review**
 - CDR POC: Michael Raymer
-



Backup Slides

Critical Design Review



Airbeam Expansion Forces



- **Maximum Expansion Forces**

- 9 Airbeams
- Area of 28 – sq. in.
- Peak Force – 127-lbf

- **With intended method of airbeam contraction, nearly peak force should be maintained throughout inflation**

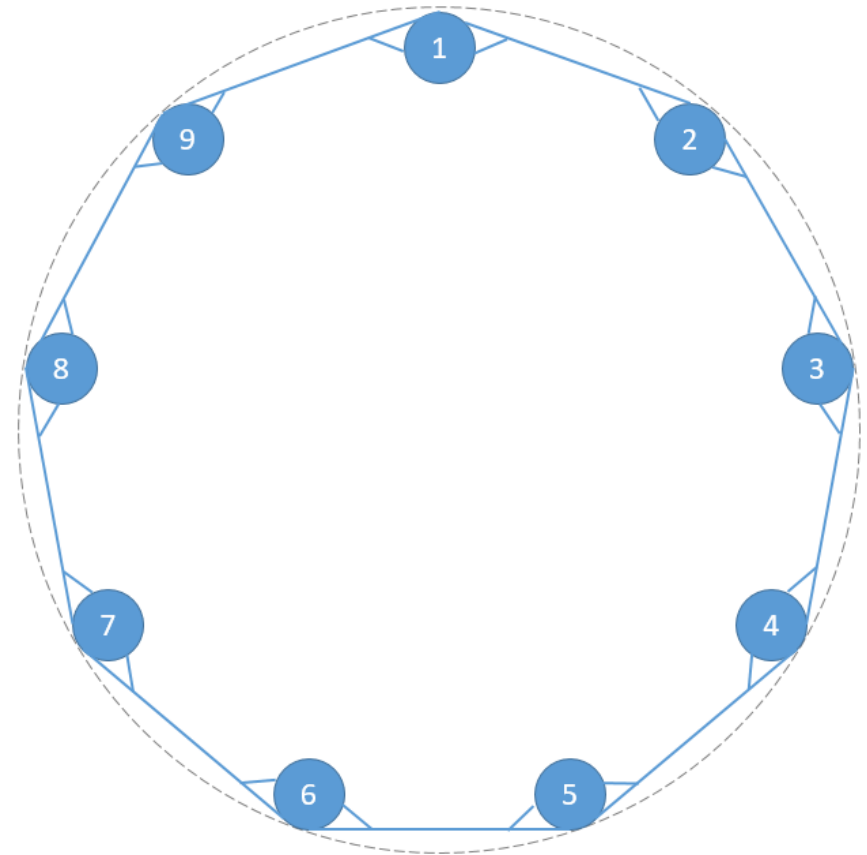



Engineering Specialty Plan (1/5)

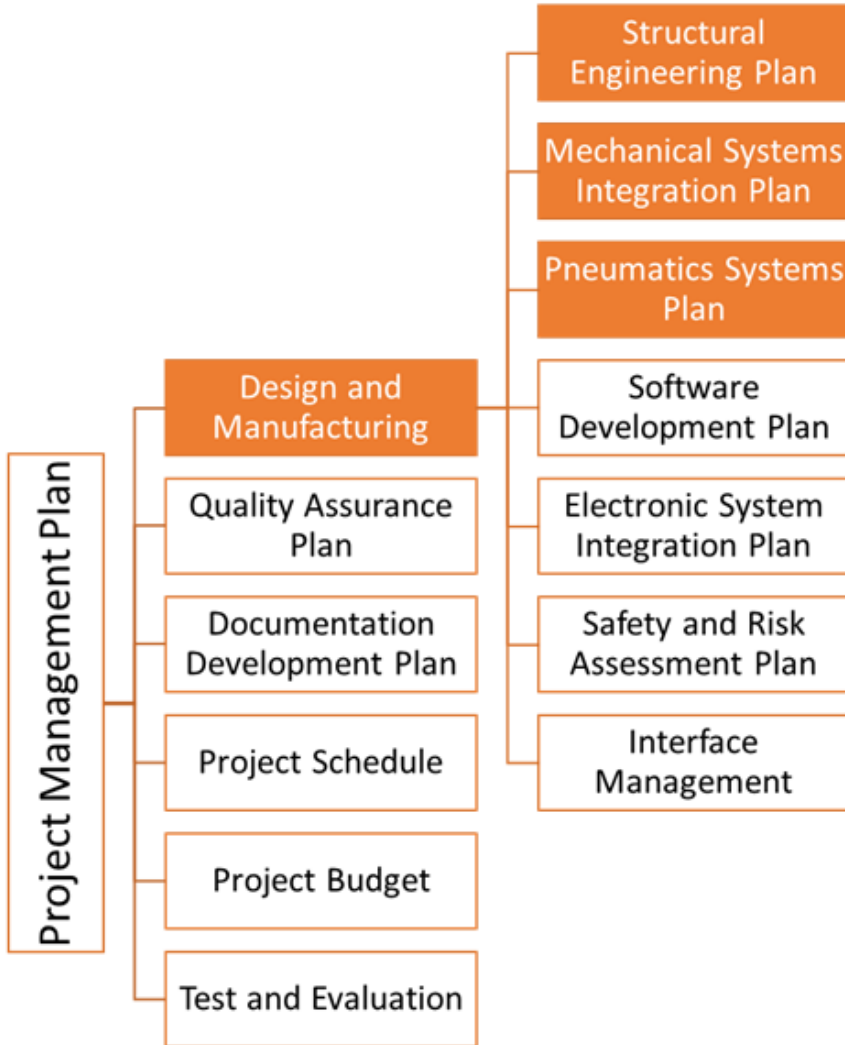

▪ **Structural Engineering**

- 8020 reduces need for specialty skills
- Manufacturing for custom hinges and non-critical components

▪ **Mechanical Systems Integration**

- Winches tested for maximum performance under expected power
- Manufacture supports accordingly

▪ **Pneumatics Systems**

- Air beam strength validated through testing
- Pneumatics all off the shelf, manufacturer specs used



Engineering Specialty Plan (2/5)

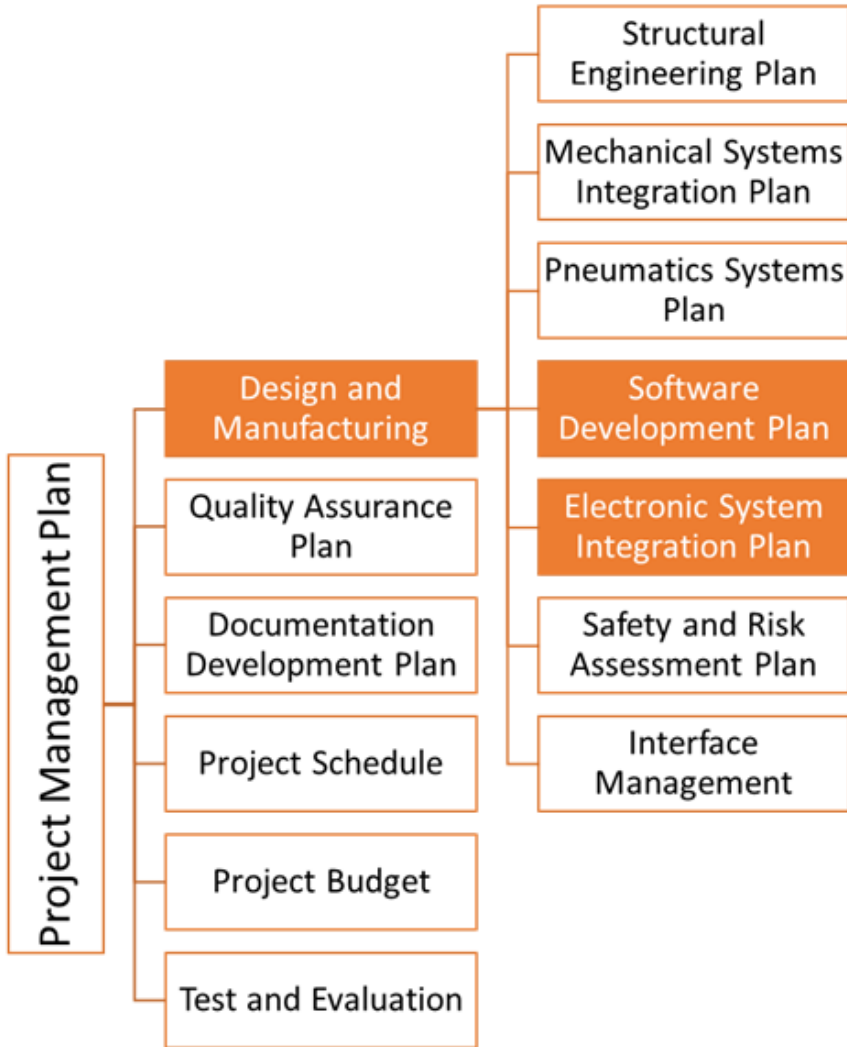

▪ **Software Development Plan**

- Software will be written in language compatible with Raspberry Pi or NI controllers
- Parallel development of documentation

▪ **Electronic System Integration Plan**

- Space will be reserved solely for electronics
- Clean, neat, and labelled organization of wires
- Parallel development of documentation



Engineering Specialty Plan (3/5)

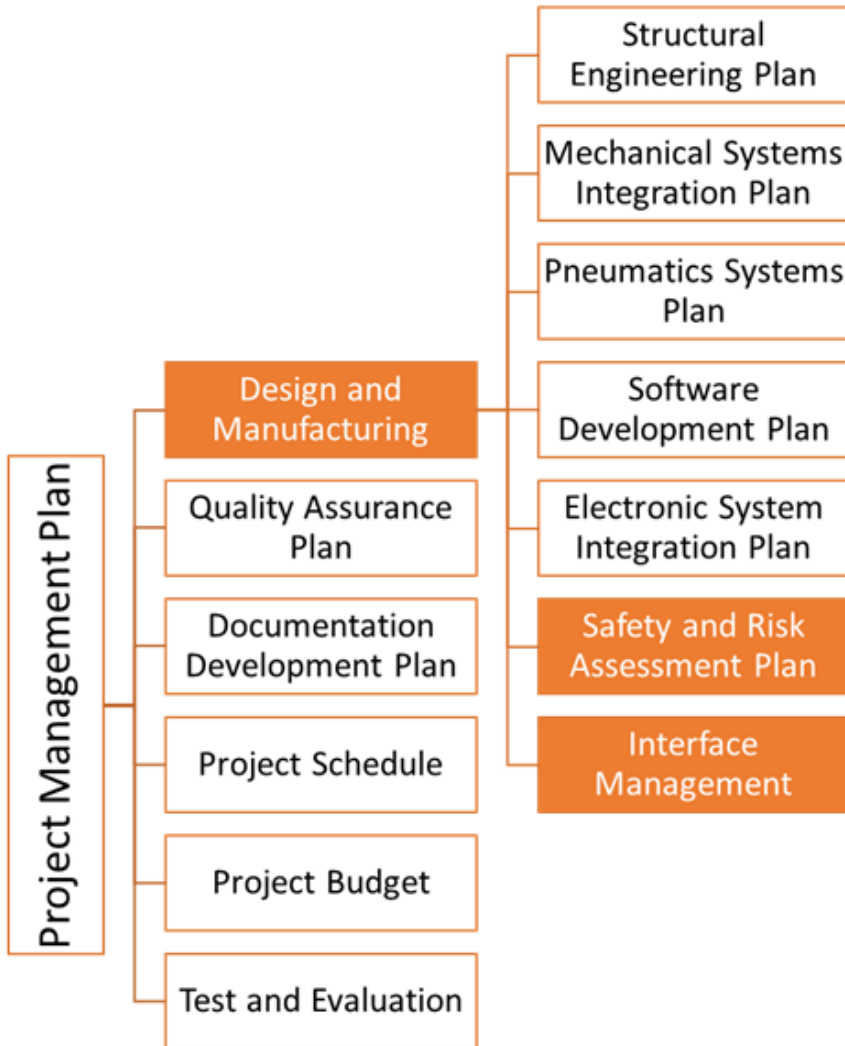

▪ **Safety and Risk Assessment Plan**

- Proper prior safety mitigation procedures
- Designate someone as safety coordinator for build and testing processes

▪ **Interface Management**

- Ensure communication between sub-teams
- Easily available, detailed documentation and design before building begins
- Proper testing and quality checks



Engineering Specialty Plan (4/5)

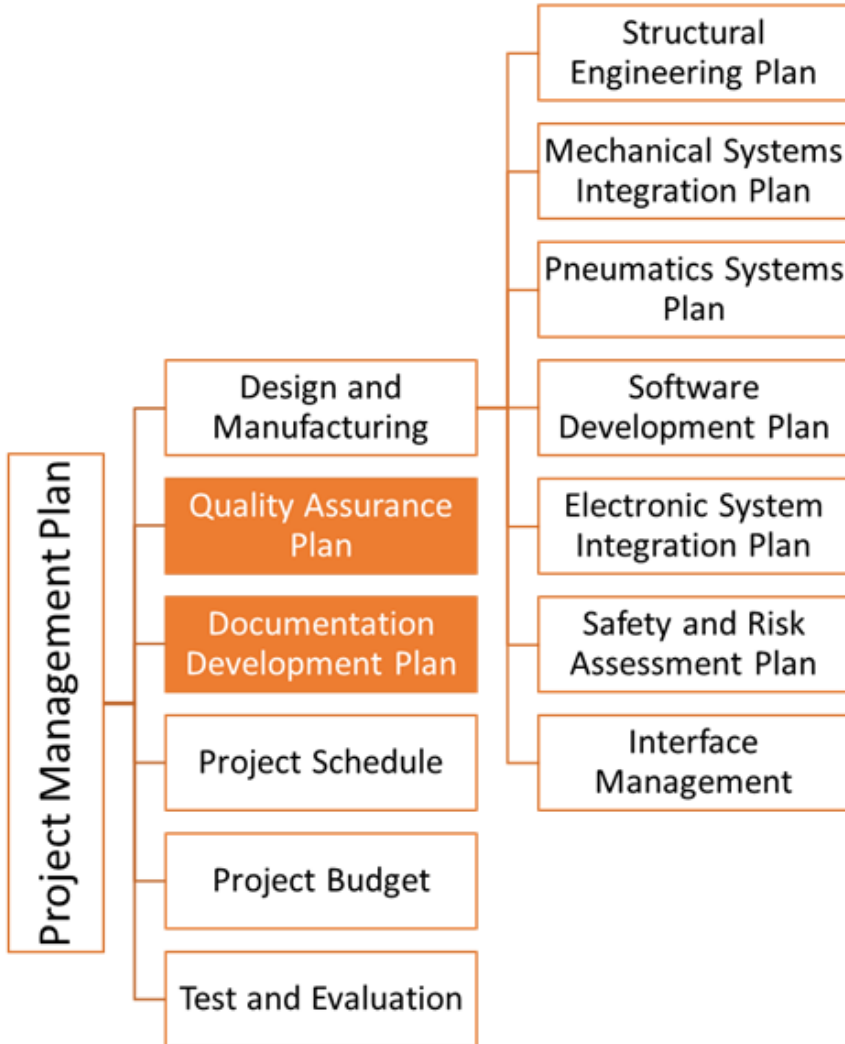

▪ **Quality Assurance Plan**

- Enact review procedures before any permanent fixtures are created
- Rigorous testing process prior to delivery

▪ **Documentation Development Plan**

- Task one person with documentation of all major team tasks and schedule progress
- Require periodic written sub-team reports



Engineering Specialty Plan (5/5)

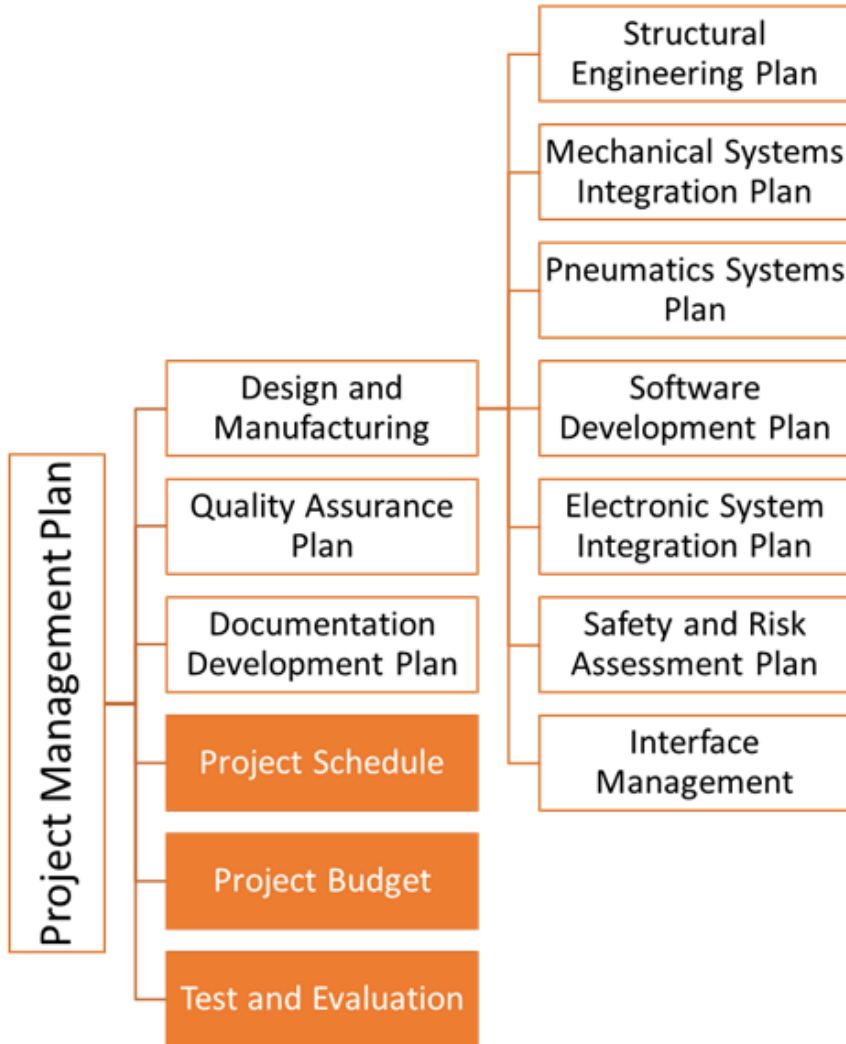

▪ **Project Schedule**

- Tentative schedule established at CDR
- Revised bi-weekly
- Regular communication with NASA contact

▪ **Project Budget**

- Expected spending established at CDR
- Updated with purchases
- Regular communication with NASA contact and university

▪ **Test and Evaluation**

- Individual systems tested and validated separately for loads & performance
- System evaluation in weeks prior to delivery



Hazard Summary

(1/5)



Hazard Description	Cause	Effect	Category		Mitigations
			Personnel	Assets	
01 Electrocution	<ol style="list-style-type: none"> Exposed wires Improper electrical setup 	<ol style="list-style-type: none"> Damage to electrical components Injury to personnel 	4E	4E	<ol style="list-style-type: none"> Careful attention during soldering, wiring, assembling. Inspection of electrical & wiring systems by one of the team's systems engineer.
02 Fire	<ol style="list-style-type: none"> Electrical components malfunction or complete failure resulting in overheating and catching fire. 	<ol style="list-style-type: none"> Injury or death to personnel. Damage to or loss of analog 	3E	3E	<ol style="list-style-type: none"> Students, OSU & NASA personnel assess equipment prior to testing for fire mitigation. Manual temp monitoring. There will be temperature sensors in the analog. These are monitored in real-time by the operator. Circuit breakers installed appropriately. Operator has direct control to cut power immediately. Sensors installed for smoke. Fire extinguishers on standby for immediate use



Hazard Summary (2/5)



Hazard Description	Cause	Effect	Category		Mitigations
			Personnel	Assets	
03 CO2	1. Too many personnel in the analog for too long	1. Headaches, dizziness, mental underperformance	4E	NA	1. CO2 sensor installed and routinely checked 2. Analog is properly ventilated, naturally, by having the dock portion open to ambient air
04 Structural Failure	1. Damage during deployment 2. Loss of beam pressure 3. 8020 beam failure	1. Damage to equipment/structure 2. Entrapment 3. Collapse causing injury	3E	3D	1. Quality control throughout construction 2. Routine inspections 3. Redundant structures 4. Pneumatic system continuously monitored by team's systems engineer via user interface 5. Emergency egress effective and briefed to personnel



Hazard Summary

(3/5)



Hazard Description	Cause	Effect	Category		Mitigations
			Personnel	Assets	
05 Minor Injuries	1. Sharp edges Trip hazards	1. Fillet or cover all sharp edges 2. Ensure power cords or analog components are not posing a risk to tripping personnel	4C	NA	1. Quality control throughout construction 2. Routine inspections 3. Redundant pressure lines/components
06 Thermal	1. Demonstration moved outside 2. Facility's AC not functioning 3. Lack of hydration	1. Dehydration 2. Heat stress 3. Heat exhaustion 4. Heat stroke	4D	NA	1. Utilize facility cooling equipment 2. Limited time outdoors 3. Ensure personnel's hydration



Hazard Summary

(4/5)



Hazard Description	Cause	Effect	Category		Mitigations
			Personnel	Assets	
07 Compressor Explosion	1. Exceeding allowable pressure limits of the tanks.	1. High-speed blasts of air. 2. Shrapnel and debris flung outward	1E	2E	1. Monitoring pressure gauges, while staying well below tanks pressure limits. 2. Routine inspections 3. Redundant pressure lines/components. This complies JPR 1700 6.11 Pressurized Gas and Liquid Systems
08 Pneumatic System Lines	1. Exceeding allowable pressure limits of pneumatic lines. 2. Hole puncture or tear.	1. Medium-speed blasts of air.	NA	4D	1. Redundant pressure lines/components 2. Routine inspections This complies JPR 1700 6.11 Pressurized Gas and Liquid Systems



Hazard Summary (5/5)



Hazard Description	Cause	Effect	Category		Mitigations
			Personnel	Assets	
09 Entering Confined spaces.	1. Low ceiling. 2. Minimum walking space.	1. Minor body impact 2. Tripping, falling	4C	NA	1. Entry procedure. 2. Padding on exposed hard surfaces. This complies JPR 1700 6.10 Entering Confined Spaces and Controlled Areas



STARGATE Design Solution Analog Floor Design



First Drawbridge Proposal:

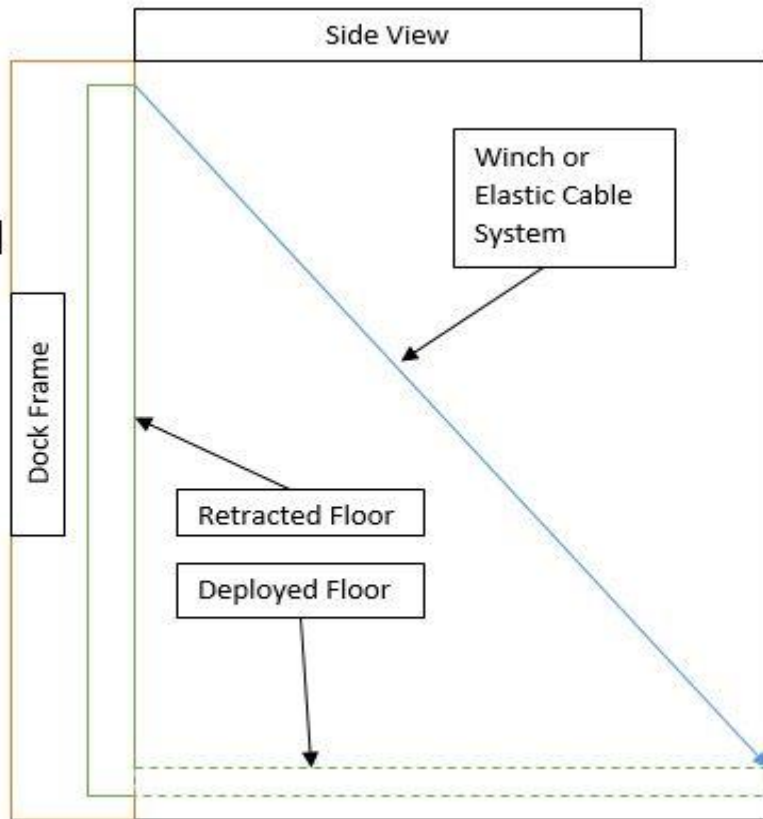

Second Hinged Drawbridge Proposal:

