

C O N T E N T S  
MINUTES OF A REGULAR MEETING  
BOARD OF REGENTS OF THE UNIVERSITY OF OKLAHOMA  
MAY 12, 1977

Minutes of the regular meeting held on April 14,1977 (14407)

Minutes of the special meeting held on April 22,1977 (14407)

REPORT OF THE PRESIDENT OF THE UNIVERSITY (14407)

Budget Committee Report

**1. Advance Refunding of Utility Bonds (14408)**

Facilities Planning Committee Report

1. Sale of Land - Noble Air Field (14409)
2. Tulsa Family Practice Clinic Lease (14410)
3. Lloyd Noble Center Roof (14410)

Student Affairs Committee Report

1. Student Congress Bill on Open Meetings of Advisory Councils (14411)

A. General University

I. Administration

- a. Acting President Policy (14413)

II. Academic

- a. Revision of Faculty Senate and General Faculty Charter, Norman Campus (14414)

III. Finance and Management

- a. University Retirement Plan Revisions (14415)

B. The Health Sciences Center

II. Academic

- a. Personnel Actions (14425)

III. Finance and Management

- a. Non-Academic Personnel Actions (14429)
- b. Purchase of Audio-Visual Equipment (14429)
- c. Movable Equipment, College of Nursing Building (14430)  
Advance Refunding of Utility System Bonds, Series 1975 (14408)
- d. Proposal, Contract, and Grant Report (14431)

V. Operations and Physical Plant

- a. College of Pharmacy Building (14432)
- b. Bids on College of Nursing Building Casework (14432)
- c. Acceptance of Project J (14434)
- d. Acceptance of Thrombosis-Coagulation Laboratory Renovation (14434)
- e. Agreement - Pedestrian Corridor (14435)
- f. Lease to Veterans Administration Hospital for Parking (14436)
- g. Report on Major Capital Improvement Projects (14437) Tulsa Family Practice Clinic Lease (14410)

VII. University Relations

- a. Trustees for University Hospital and Clinics (14437)

- C. Academic (Norman Campus)
  - I. Personnel Actions (14437)
  - II. Programs
    - a. Linguistics Program - Bachelor of Arts (14441)
    - b. Real Estate Program (14442)
    - c. Classics Program - Bachelor of Arts (14443)
    - d. Resolution of Commendation - Chemical Engineering (14444)
  
- D. Finance and Management (Norman Campus)
  - I. Non-Academic Personnel Actions
    - a. Educational and General, Special Agency, and Service Units (14445)
    - b. Grants and Contracts (14446)
  - VI. Purchases
    - a. Lease/Purchase of Additional Memory for Computer (14446)
    - b. Offset Printing Paper for University Press (14447)
    - c. Offset Paper for Journalism Press (14448)
    - d. Bread and Bread Products (14448)
    - e. Orange Juice and Grape Juice (14449)
    - f. Front-Loader Refuse Truck (14450)
    - g. Offset Newsprint (14451)
  - VII. Project Financing
    - a. Proposal, Contract, and Grant Report (14452)
  - XI. Organizational Changes
    - a. Center for Environmental Design and Research (14453)
  
- F. The University Community (Norman Campus)
  - IV. Student Conduct
    - a. Code of Conduct - College of Law (14457)
  - V. Student Government
    - Student Congress Bill on Open Meetings of Advisory Councils (14411)
  
- G. Operations and Physical Plant (Norman Campus)
  - I. New Construction
    - a. Athletic Dormitory (14465)
    - b. Report on Major Capital Improvement Projects (14465)
      - Lloyd Noble Center Roof (14410)
  - II. Repairs, Remodeling, Renovation
    - a. Safety Modifications - DeBarr Hall (14465)
  - IV. Contracts and Agreements
    - a. Summer Institute of Linguistics (14466)
  - V. University Property
    - a. Ellsworth Collings Hall (14467)
      - Sale of Land - Noble Air Field (14409)
  
- H. University Development
  - V. Gifts and Bequests
    - a. Notification of Gift (14468)

MINUTES OF A REGULAR MEETING  
BOARD OF REGENTS OF THE UNIVERSITY OF OKLAHOMA  
MAY 12, 1977

A regular meeting of the Board of Regents of The University of Oklahoma was held in the East Lecture Room of the Basic Sciences Education Building on the Health Sciences Center Campus, Oklahoma City, on May 12, 1977, beginning at 10:35 a.m.

The following were present: Mr. Thomas R. Brett, President of the Board, presiding; Regents Bob G. Mitchell, M.D., K. D. Bailey, Dee A. Replogle, Jr., Charles E. Engleman, and Ronald H. White, M.D.

Absent: Regent Richard A. Bell.

The following were also present: Dr. Paul F. Sharp, President of the University; Provosts Uehling and Thurman; Vice Presidents Burr, Dean, Morris, Nordby, and White; Executive Assistant Joseph C. Ray; Mr. R. Boyd Gunning, University Trust Officer; Dr. Thomas H. Tucker, University Chief Counsel; and Mrs. Barbara H. James, Executive Secretary of the Board of Regents.

The minutes of the regular meeting held on April 14, 1977, were approved as printed and distributed prior to the meeting on the following affirmative vote: Regents Brett, Mitchell, Bailey, Replogle, Engleman, and White.

The minutes of the special meeting held on April 22, 1977, were approved as printed and distributed prior to the meeting on the following affirmative vote: Regents Brett, Mitchell, Bailey, Replogle, Engleman, and White.

As his report, President Sharp commented on the following five items:

1. The positive quality and spirit of the graduating classes this year and the very interesting shift in attitudes represented by this graduating class.

2. A resolution included in the agenda which will be considered later by the Regents pertaining to the distinction that our program in Chemical Engineering has achieved. President Sharp said this is a remarkable achievement and one that signals our emphasis on quality and is a notable expression of the kinds of concerns the Regents have expressed over the past six years.

-3. The modest but very important gains the University is making in affirmative action commitments on both campuses. He called attention to the fact that of the new hires for 1977-78 on the Norman Campus in temporary and continuing faculty Members, 41% are women and 14% are minorities. President Sharp said we regard that to be a significant step in advancing our affirmative action commitments and goals.

4. That Provost Barbara Uehling has been elected President of the Association of Higher Education, a national association of higher education officials representing most of the higher education institutions in the United States. He said this is a signal honor and representative of the kinds of things which our colleagues are performing as individuals as well as through our corporate exercises.

5. A speech made by Dr. Clark Kerr, Chair of the Carnegie Commission on Higher Education Special Commission which is studying higher education, about what higher education would be like in 2001, in which he predicts that higher education leadership is going to come from new regions in the United States. Dr. Kerr's point was that the sun belt area of the United States is going to provide the leadership for the next generation and he specifically named the University of Oklahoma in that speech as one of the institutions that he looked to to provide not only regional leadership but national leadership.

#### Advance Refunding of Utility Bonds

The preliminary official statements pertaining to the advance refunding of the Regents Utility System Revenue Bonds, Series 1975, copies of which are attached hereto as a part of these minutes, were distributed to the Regents with the agenda for this meeting. Regent Replogle said this matter was discussed at the Budget Committee meeting yesterday with Mr. Robert Lewis and Mr. Rod Durrell of Leo Oppenheim & Co., Bond Financial Consultant, and with Bond Counsel, Mr. Scott Brown.

Regent Replogle said the Committee recommends approval of President Sharp's recommendation that the Board authorize a negotiated sale for the advance funding and adopt the following Resolution approving the preliminary official statements for submission to the Oklahoma State Regents for Higher Education for approval of the Statement of Essential Facts, and authorize the preparation of the final statements:

WHEREAS, it has been determined that a substantial savings might be had by the University of Oklahoma if the Regents advance refunded their presently outstanding Utility System Revenue Bonds, Series 1975; and

WHEREAS, the financial consultants of the University of Oklahoma have prepared two Official Statements pertaining to the issuance of two bond issues, the net proceeds of which shall be used to effect such advance refunding at the maximum savings to the University; and

WHEREAS, the staff of the University has reviewed said Official Statements and determined that the advance refunding will result in a substantial savings to the University and further that, based upon the facts and projections, the projected revenue will satisfy the financial obligation to be incurred under the proposed bond issues.

NOW, THEREFORE BE IT RESOLVED BY THE BOARD OF REGENTS OF THE UNIVERSITY OF OKLAHOMA:

SECTION 1. The Preliminary Official Statement ;Pertaining to the issuance by the Regents of approximately \$6,850,000 Utility System Revenue Refunding Bonds, Series 1977 for the purposes set out in said Official Statement is hereby approved.

SECTION 2. The Preliminary Official Statement pertaining to the issuance by the Regents of approximately \$3,700,000 Utility System Special Obligation Refunding Bonds, Series 1977 for the purposes set out in said Official Statement is hereby approved.

SECTION 3. Said Official Statements which contain the Statement of Essential Facts for the use and information of prospective bond purchasers are hereby directed to be delivered to the Oklahoma State Regents for Higher Education for examination and certification to the Attorney General for the State of Oklahoma.

Regent Replogle said this would represent a saving of approximately \$18,000 per year over a 28-Tear period for a total saving of over \$500,000.

Regent Replogle moved approval of the recommendation. The motion was unanimously approved on the following affirmative vote: Regents Brett, Mitchell, Bailey, Replogle, Engleman, and White.

Regent Mitchell presented the following report of the meeting of the Facilities Planning Committee:

Sale of Land - Noble Air Field

The Norman School District is searching for a school site in southeast Norman and has expressed interest in land owned by the University in Section 3 of Cleveland County. The property in question is a portion of what is known as the Noble Air Field east of 24th Avenue, S.E., between Lindsey and Imhoff Road.

Regent Mitchell said the Norman School District is interested in an area approximately 800 feet by 1,000 feet with the south boundary on the center line of the section, approximately 18.36 acres. The District has offered \$3,500 per acre for the 18.36 for a total price of \$62,260.

Regent Mitchell said this was reviewed by the Facilities Planning Committee and the Committee recommends approval of President Sharp's recommendation that this offer be accepted and the property sold to the Norman School District at \$3,500 per acre, subject to approval of the sale by the Federal Aviation Administration.

Regent Mitchell moved approval of the recommendation. The following voted yes on the motion: Regents Brett, Mitchell, Bailey, Replogle, Engleman, and White. The Chair declared the motion unanimously approved.

Tulsa Family Practice Clinic Lease

At the April 14 meeting the Board approved entering into a lease agreement with Murphy and Murphy covering space for a second family practice model unit in Tulsa, located at 9912 East 21st Street South. Information presented to the Board at that time indicated the rental rate for the primary term of the lease would be \$7,984.20 per month, which included the cost of renovating the building in accordance with plans and specifications approved by the University up to a maximum amount of \$125,000. Since that time, the owners of the building have received the bids for renovating the space in accordance with the University's plans and specifications and the costs will be more than \$125,000. A change in the rental rate for the first year of the lease has been proposed to \$9,161.10 per month with the understanding the renovation costs will be less than \$150,000.

Funds will be available in the E & G Budget to cover this additional cost for next year.

President Sharp recommended approval of the modification of the lease with Murphy and Murphy covering the space at 9912 East 21st Street South in Tulsa for the second family practice model unit as explained above.

Regent Mitchell said this was discussed by the Facilities Planning Committee yesterday and the Committee recommends approval of President Sharp's recommendation. He moved approval. The following voted yes on the motion: Regents Brett, Mitchell, Bailey, Replogle, Engleman, and White. The Chair declared the motion unanimously approved.

Lloyd Noble Center Roof

Regent Mitchell said the following report on the Lloyd Noble Center roof was presented at the Facilities Planning Committee meeting by Dr. Tucker:

On March 15, 1977, after discussion with the Facilities Planning Committee, the University's attorney offered to pay Rayco Construction Company \$200,820.63 of the money which we have retained under our contract with them if they would re-roof the Lloyd Noble Center according to roof repair specifications prepared by the architectural and engineering staff of the University of Oklahoma. The attorneys for Rayco have indicated acceptance of the proposal.

The \$200,820.63 represents a portion of the money which we have not paid Rayco for the construction of the building. In other words, we have held back a portion of the money due Rayco for the reason that the job done was not satisfactory. This partial settlement agreement, which will enable us to complete the roof, provides that the University will maintain continuous inspection of the work in progress (so that disputes regarding performance can be avoided) and will pay the agreed retained portion of money to Rayco immediately upon completion of the roof.

Since the roof is only one, albeit the largest, of the problems associated with the arena, it is important that everyone understand the manner in which

we are dealing with the problems so that we may continue to solve them in sequence. Legal Counsel, therefore, requested that the Board take whatever action is necessary to authorize payment to Rayco in the above amount upon completion of the roof so that we might proceed at once with the necessary re-roofing.

Regent Mitchell said the Committee recommends approval of President Sharp's recommendation that the Board authorize the payment of \$200,820.63 to Rayco Construction Co. upon completion of the roof as per the specifications prepared by the University's Architectural and Engineering Services, and he so moved. The following voted yes on the motion: Regents Brett, Mitchell, Bailey, Replogle, Engleman, and White. The Chair declared the motion unanimously carried.

Student Congress Bill on Open Meetings of Advisory Councils

The following Student Congress Bill was adopted by Student Congress in March, 1977:

Title: AN ACT CALLING FOR OPEN MEETINGS AT ALL ADVISORY BOARDS TO THE PRESIDENT OF THE UNIVERSITY OF OKLAHOMA

Section 1: This act shall be known and may be cited as AN ACT CALLING FOR OPEN MEETINGS AT ALL ADVISORY BOARDS TO THE PRESIDENT OF THE UNIVERSITY OF OKLAHOMA.

Section 2: The purpose of this act is to guarantee the integrity and accountability of all advisory board sessions.

Section 3: It shall be the policy of this institution that all advisory council's proceedings be open to the public with the specific exceptions provided for in the State of Oklahoma's open meetings laws.

Section 4: This act is hereby enacted.

Section 5: This act shall become effective when passed in accordance with the UOSA Constitution.

President Sharp responded as follows on March 22, 1977, to Mr. John Bode, then President of the Student Association:

"This is in response to Congressional Bill Number 171406, 'An Act Calling for Open Meetings at all Advisory Boards to the President of the University of Oklahoma'.

"The University of Oklahoma's Legal Counsel advised sometime ago that because each of the councils and committees of the University are recommending bodies to the President and not decision-making bodies as such, there is no legal

requirement that any of their meetings be open. Thus, the decision as to whether meetings of these advisory bodies are to be open or closed may be made differently council by council and committee by committee.

"This situation was recognized by the University of Oklahoma Student Association in Ms. Cathy Kidd's January 28, 1975 letter to me on this subject. In that letter, however, Ms. Kidd made a very good and useful suggestion that the councils and committees be asked to decide for themselves whether their meetings would be open or closed.

"Based upon Ms. Kidd's suggestion, I wrote to the chairs of each of the councils and committees on February 18, 1975 asking each committee (1) to determine whether it has a procedure clearly established for deciding whether its meetings will be open or closed and, if open, under what circumstances and (2) to make a decision on whether the meetings will be open or closed if such a decision had not already been reached by the committee or council.

"Given the legal situation and the fact that the councils and committees are advisory, I am reluctant to force any advisory council, board or committee to either open or close their meetings to those who do not regularly sit with the council or committee. This decision most appropriately should rest with the individual councils and committees themselves. Consequently, I cannot approve Congressional Bill Number 171406."

Student Congress subsequently voted to override the Presidential veto and the matter was referred to the Board of Regents for consideration in accordance with the UOSA Constitution. Regent White said the Bill was discussed at length at the Student Affairs Committee meeting yesterday with President Sharp, Vice President Morris, other members of the administration, and with student leaders.

Regent White said the Committee recommends that President Sharp's veto be upheld, but that the President be requested to communicate to the various advisory councils and committees the administration's view of adhering to the principles of openness and that the meetings of the advisory councils and committees should be open unless it is thought that it is in the best interests of the University for specific meetings to be closed.

Regent White moved approval of the recommendation. The following voted yes on the motion: Regents Brett, Mitchell, Bailey, Replogle, Engleman, and White. The Chair declared the motion unanimously approved. President Sharp commented that this will be shifting the emphasis from the assumption that the council and committee meetings will be closed to an assumption that the meetings will be open unless there is reason to be closed.

Regent Brett recognized at this time Mr. Carter Bradley, Executive Director of the Higher Education Alumni Council. Mr. Bradley commented at length on the status of the higher education appropriation bill in the Legislature. He urged each Regent to contact the Governor's Office or members of the



Legislature with whom they are acquainted and insist on an increase in the appropriation for higher education about which there has been some discussion. Mr. Bradley believes the chances of holding the higher figures that are now in the appropriations bill are slim. However, he said, if there are increases in other appropriations over the Governor's budget, our position should be that higher education should have an appropriation increase beyond the Governor's budget.

Mr. Bradley commented that the natural gas tax bill now provides for earmarking these funds for the Public Employees Retirement Fund. He hopes that this earmarking provision can be removed from the bill before final passage. Mr. Bradley also commented on the need for and feasibility of a new bond issue to support capital improvements for higher education.

#### A. General University I.

##### Administration

###### a. Acting President Policy

President Sharp recommended adoption of the following revised Acting President policy:

Whereas, on occasion the President of the University of Oklahoma, on account of official business, vacation, illness, or other unavoidable cause, is absent from the campuses of the University of Oklahoma; and

Whereas, during such absence by the President of the University of Oklahoma it is essential that provision be made so that payrolls and other official documents be signed or executed in the same manner as if the President of the University were present;

##### NOW THEREFORE BE IT RESOLVED:

1. That in the temporary absence of the President, the Provost, Norman Campus, is hereby authorized to serve as Acting President of the University and to sign payrolls and other official documents that normally would be signed by the President of the University; and

2. That in the temporary absence of both the President and the Provost, Norman Campus, the Vice President for Administration and Finance is hereby authorized to serve as Acting President of the University and to sign payrolls and other official documents that normally would be signed by the President of the University; and

3. That in the temporary absence of the President, the Provost, Norman Campus, and the Vice President for Administration and Finance, the Vice President for the University Community is hereby authorized to serve as Acting President of the University and to sign payrolls and other official documents that normally would be signed by the President of the University; and

4. That in the event any of the above named positions are filled by persons in an acting or interim capacity, the line of succession shall automatically be directed to the next position; and

5. That in the event the President of the University shall resign, be incapacitated, be on an extended leave of absence or otherwise be unable to perform the duties for a period in excess of 30 days, an Acting or Interim President shall be designated by the Board of Regents. The Acting or Interim President shall have all powers, duties, and responsibilities normally devolving upon the Office of the President of the University.

The next time the Norman Campus Faculty Handbook is revised the following phrase in the first line of Section 2.3.2 will be omitted: ".... is the second-ranking officer of the University on the Norman Campus and..."

Regent Replogle moved approval of the recommendation. The following voted yes on the motion: Regents Brett, Mitchell, Bailey, Replogle, Engleman, and White. The Chair declared the motion unanimously carried.

## II. Academic

### a. Revision of Faculty Senate and General Faculty Charter, Norman Campus

The Norman Campus Faculty Senate has proposed a revision of the Norman Campus General Faculty and Faculty Senate Charter. The revision was approved at the April 14 meeting of the Norman Campus General Faculty. The change would provide non-voting Senate membership for the Association of Graduate Student Employees on the Norman Campus.

President Sharp recommended approval of the following change in the last sentence of the third paragraph of the section on the composition of the Faculty Senate in the Charter of the General Faculty and the Faculty Senate, Norman Campus:

From:

"Six representatives of the Association of the University of Oklahoma Professional Employees and one representative of the Provost's Office also attend meetings and participate, without voting privileges, in Senate discussion."

To:

"Six representatives of the Association of the University of Oklahoma Professional Employees, two representatives of the Association of Graduate Student Employees of the University of Oklahoma, and one representative of the Provost's Office also attend meetings and participate, without voting privileges, in Senate discussion."

Regent Replogle moved approval of the recommendation. The following voted yes on the motion: Regents Brett, Mitchell, Bailey, Replogle, Engleman, and White. The Chair declared the motion unanimously carried.

### III. Finance and Management

#### a. University Retirement Plan Revisions

The University Fringe Benefits Committee has studied desirable changes in the University Retirement Plan over the past several years. Following consultation with the chairs of the Faculty Senate (Norman Campus), Faculty Senate (HSC), Employee Executive Council (Norman Campus), and the Employee Liaison Council (HSC), the Committee has recommended revisions to the University Retirement Plan which will provide for earlier optional retirement and other improvements. The plan changes are summarized as follows:

1. Years of Service. The definition has been updated to incorporate a long standing practice of including years of service to the University following age 65 for the purpose of establishing years of service in making Supplemental Benefits computations.
2. Normal Retirement. The definition of normal retirement has been changed to provide for (a) continuation of the present normal retirement provisions for persons employed prior to September 2, 1977; (b) normal retirement at age 65 for persons employed after September 2, 1977; and (c) exceptions to normal retirement may be approved by the President after an appropriate campus faculty - staff - administration committee, designated by the President, has reviewed the matter.
3. Optional Retirement. The effective date of Optional Retirement has been changed to June 30, rather than July 1, in order to give retirees the benefit of any increases in Teachers' Retirement System or Social Security benefits that become effective on July 1 of the year in which they retire.
4. Disability Retirement. This paragraph has been changed to provide that disability retirement may be approved by the President after an appropriate campus faculty - staff - administration committee, designated by the President, has reviewed the matter. For faculty members, a recommendation for disability retirement will be processed through the budget committee of the department and the appropriate academic dean. Approval action will be based upon the presentation of reasonable medical evidence, rather than a medical board's findings, that an individual is incapable of further performance of duties, that such incapacity is likely to be permanent and that the person should be retired.
5. Supplemental Benefits. Benefits from the Retirement Addition (TIAA-CREF) have been included as an offset to Supplemental Benefits. This was taken care of in the policy statement con-

cerning the Retirement Addition but has not been included to this point in the Retirement Plan.

6. Supplemental Benefits. Provision has been made to use the highest level of wages and salaries upon which contributions may be made to Teachers' Retirement System of Oklahoma (TRS) for the computation of TRS benefits to be used as an offset in the Supplemental Benefits computation.
7. Supplemental Benefits. Provision has been made to continue Optional Retirement with full benefits at age 60 with 30 years service but lowers Optional Retirement for others to age 62 (a change from 65) with 10 years service (rather than 25 years of service).
8. Supplement for Disability Allowance. This provision has been changed to reflect eligibility for Disability Retirement benefits prior to age 62, rather than age 65, following 10 years of service.
9. Other Retirement Benefits. An addition has been made to point out some of the other benefits available to employees upon retirement including health insurance benefits for life.

The following materials were included in the agenda: (1) documents outlining the current and proposed University Retirement Plans as they are applicable to the two campuses; (2) cost/savings analysis report; and (3) estimated cost impact analysis for the next five years.

Approval of these changes will make the Retirement Plan for the Health Sciences Center and Norman Campus essentially the same. The principal difference is that the Health Sciences Center plan will retain the \$15,000 maximum supplement benefits stipulation which has not appeared in the Norman Campus plan in the past.

President Sharp recommended approval of the revisions to the University Retirement Plan as outlined effective July 1, 1977. The new plans are shown below:

#### RETIREMENT PLAN - NORMAN CAMPUS

Regular employees of the University of Oklahoma are entitled to certain retirement benefits following the completion of a designated number of years of employment, the attainment of specified ages and satisfaction of other requirements as set forth in this statement.

Definition of Terms: Unless a different meaning is plainly indicated by the context, certain terms used in this statement on retirement will have the following meanings:

1. "Retirement" applies to the termination of employment of employees satisfying certain criteria of length of service, age, and employment status as indicated below entitling them to retirement benefits.
2. The abbreviation "TRS" means Teachers' Retirement System of Oklahoma.
3. "Social Security" means the Federal Social Security Benefits Pro-gram.
4. "Retirement Addition" refers to the fully funded annuity program through TIAA-CREF made available to employees earning in excess of \$9,000 per year.
5. "Supplemental Benefit" means a retirement benefit paid to a member of TRS from the current operating funds of the University subject to the statutes of the State of Oklahoma as a supplement to benefits from TRS, Social Security, and the Retirement Addition.
6. "Member" refers to an employee who is a member of TRS on an optional or mandatory basis. Eligibility for membership is defined by the Board of Trustees of TRS.
7. "Annual Salary Rate" in the case of a member employed regularly on a 9-month academic year basis means the full-time salary for the 9 months employment period plus two-ninths to convert the 9-month rate to a 12-month equivalent rate. A member who is employed regularly on a part-time basis may be eligible for the Supplemental Benefit, but his/her annual salary rate as defined in the preceding sentence will be limited to his/her part-time rate for the 9-month employment period plus the amount sufficient to convert the 9-month rate to a 12-month equivalent rate. The annual salary rate for a member who is employed full time on an hourly rate will be computed by multiplying the hourly rate by 2080 hours.
8. "Years of Service" shall include only those years the employee has been a member of TRS and those years for which the employee shall have received prior service credit, in accordance with paragraph 10 below, and all time on sabbatical and military leave from the University of Oklahoma, the first year of any other year of leave of absence from the University of Oklahoma, and years of University of Oklahoma employment after age 65 which follows TRS membership.
9. "Minimum Retirement Age" with supplemental benefits shall be 60 years for an employee who has completed 30 years employment with the University and 62 years for those who have completed at least 10 years employment.
10. "Prior Service Credit" shall be granted for:
  - a. Those years for which the employee was employed by the Univer-

sity of Oklahoma prior to July 1, 1943, and for which the employee has received prior service credit with TRS, and

- b. A maximum of five years of prior service credit may be granted on the basis of one year's credit for each four full years (nine or more months) of full-time service at any accredited institution of higher education. Credit for service of fractions of less than four full years of service will not be considered.
11. "Supplemental Employment" means the employment of a retired member of TRS for a temporary period not to exceed the maximum per year established by regulations of TRS without affecting the member's status or benefits.

### Retirement Age

Normal Retirement: Any person employed by the University prior to September 2, 1977, who has not retired earlier will retire at the end of the fiscal year (July 1 - June 30) during which age 70 is reached; an executive officer or administrative officer will retire from his/her administrative position at the end of the fiscal year during which age 68 is reached. Effective September 2, 1977, and thereafter, any employee of the University who has not retired earlier will retire at the end of the fiscal year during which age 65 is reached. Exceptions may be approved by the President, in cases where a review has been made by an appropriate campus faculty-staff-administrative committee appointed by the President, on a year-to-year basis.

Optional Retirement: **Any** person who has completed 25 years of creditable service with the University may retire voluntarily on June 30 of any year regardless of age. Such person, however, shall not be eligible to receive University supplemental benefits until July 1 following the date he/she becomes 62 years of age. Any person who has completed 30 years of service with the University may retire voluntarily on June 30 in any year regardless of age. Such person, however, shall not be eligible to receive University supplemental benefits until July 1, following the date he/she becomes 60 years of age.

Disability Retirement: Upon application of a member or upon appropriate recommendation, any employee who has completed 10 years of University employment may be retired for disability provided that reasonable medical evidence has been presented indicating the individual is incapacitated for further performance of duty, that such incapacity is likely to be permanent and that the person should be retired. Disability retirement may be approved by the President after an appropriate campus faculty-staff-administration committee, designated by the President, has reviewed the matter. For faculty members, a recommendation for disability retirement will be processed through the budget committee of the department and the appropriate academic **dean. Disability retirement** shall be subject to reconsideration in any year prior to age 62. If evidence shows the individual so retired to be capable of performing satisfactory service in accordance with his/her education and training, retirement status may be removed.

Social Security: All University employees who are not classified as students are covered by Social Security.

Teachers' Retirement System of Oklahoma: Membership in TRS is mandatory for faculty members, executive officers, professional staff, supervisory staff, managerial staff, administrative staff, and administrative officers. Membership is optional for service and operations staff employees. Further information may be obtained from the Personnel Services Office or from Teachers' Retirement System of Oklahoma, P.O. Box 53524, Oklahoma City, Oklahoma.

(The following paragraph on Retirement Addition is a summary of and not a replacement for the Regents' action of 5-11-72, amended 2-8-73, establishing the TIAA-CREF portion of the retirement plan. These actions of the Board pertaining to TIAA-CREF remain in effect.)

Retirement Addition: Faculty and staff members whose earnings (based upon contract or appointment) exceed \$9,000 per year and who are members of the Teachers' Retirement System of Oklahoma are required to participate in a retirement addition program under Teachers Insurance and Annuity Association and College Retirement Equities Fund (TIAA-CREF) if they meet specified age, years of service or previous TIAA-CREF membership requirements. During fiscal year 1976/77, University contributions to this annuity program for participants are 9% of salary exceeding \$9,000 salary. The 9% contribution rate is projected to increase 1 1/2% each subsequent fiscal year until a 15% level is to be achieved in fiscal year 1980-81, and to continue thereafter at that 15% rate. The salary considered is the annual 9 or 12 month rate, but does not include (1) summer appointments for those on a regular 9-month appointment; (2) special payment of any kind; (3) cost of living differential on international projects; (4) housing allowances; (5) expense allowances; or (6) any amount of salary which would result in a contribution of \$1.00 or less per month. Enrollment is accomplished in Personnel Services where a more complete description of the Retirement Addition is available.

Supplemental Benefits: Benefits from Primary Social Security, TRS and Retirement Addition are combined with a Supplemental Benefit, as described below, to provide a retired employee with income protection for life. Regardless of the optional wage and salary level chosen by the member to determine TRS contributions, the benefits from TRS used in the computation of Supplemental Benefits will be based on the highest level of wages and salary upon which contributions may be made to TRS. To be eligible for Supplemental Benefits an employee must be a member of TRS.

- a. A member who has served at least 10 years but less than 25 at the time of retirement will receive a Supplemental Benefit which, when added to his/her maximum annual retirement allowance from TRS, Primary Social Security and Retirement Addition, will provide a total benefit equal to the number of years of service times two percent of his/her average full-time annual salary rate for the highest five consecutive years of service.



- b. A member with 25 years of service at the time of retirement will receive from the University an amount which, when added to a member's maximum annual retirement allowance from TRS, primary Social Security, and Retirement Addition will provide benefits equal to one-half his/her annual salary rate for the highest salaried five consecutive years of service.
- c. A member with more than 25 years of service at the time of retirement will accumulate retirement benefits at the rate of two percent per year for the first 25 years, including any prior service credit. For all service in excess of 25 years, entitlement shall accrue at the rate of one-half of one percent for each full year of service.

Supplemental for Disability Allowance: A member who retires or is retired for disability after 10 years of service will receive a Supplemental Benefit which, when added to his/her maximum annual disability retirement allowances from TRS, Primary Social Security and Retirement Addition, will provide a total annual allowance equal to the amount that the member would have received upon optional retirement based on his/her number of years of service and as if he/she were already age 62.

Supplemental Employment After Retirement: Following a review by an appropriate campus faculty-staff-administration committee and a showing of need for such service on a temporary basis, a member on retirement status may be approved for University employment on a part-time, and/or temporary basis by the President and earn up to the maximum allowed by TRS during a fiscal year without affecting his/her retirement status and benefits. Earnings from the University beyond that amount will not be permitted.

Effect of Social Security and TRS Not Retroactive: Supplemental Benefits of members who have retired shall not be changed in any way because of changes in Social Security, TRS or Retirement Addition benefits received.

Other Retirement Benefits: Employees retiring in accordance with University retirement policy as described herein will be entitled to University-paid health insurance benefits for life. They shall also be issued an employee identification card which shall entitle them to employment benefits associated with it, i.e., athletic tickets at reduced costs, use of University libraries, employee functions, University Club, etc.

#### RETIREMENT PLAN - HEALTH SCIENCES CENTER

Regular employees of the University of Oklahoma are entitled to certain retirement benefits following the completion of a designated number of years of employment, the attainment of specified ages and satisfaction of other requirements as set forth in this statement.

Definition of Terms: Unless a different meaning is plainly indicated by the context, certain terms used in this statement-on retirement have the following meanings:

1. "Retirement" applies to the termination of employment of employees satisfying certain criteria of length of service, age, and employment status as indicated below entitling them to retirement benefits.
2. The abbreviation "TRS" means Teachers' Retirement System of Oklahoma.
3. "Social Security" means the Federal Social Security Benefits Program.
4. "Retirement Addition" refers to the fully funded annuity program through TIAA-CREF made available to Health Sciences Center faculty/staff through their enrollment in Plan 001 or Plan 002, approved by Board of Regents, September 2, 1976.
5. "Supplemental Benefit" means a retirement benefit paid to a member of TRS from the current operating funds of the University subject to the statutes of the State of Oklahoma as a supplement to benefits from TRS, Social Security, and the Retirement Addition.
6. "Member" refers to an employee. who is a member of TRS on an optional or mandatory basis. Eligibility for membership is defined by the Board of Trustees of TRS.
7. "Annual Salary Rate" in the case of a member employed regularly on a 9-month academic year basis means the full-time salary for the 9 months employment period plus two-ninths to convert the 9-month rate to a 12-month equivalent rate. A member *who is* employed regularly on a part-time basis may be eligible for the Supplemental Benefit, but his/her annual salary rate as defined in the preceding sentence will be limited to his/her part-time rate for the 9-month employment period plus the amount sufficient to convert the 9-month rate to a 12-month equivalent rate. The annual salary rate for a member *who is* employed full time on an hourly rate will be computed by multiplying the hourly rate by 2080 hours.
8. "Years of Service" shall include only those years the employee has been a member of TRS and those years for which the employee shall have received prior service credit in accordance with paragraph (10) below, and all time on sabbatical and military leave from the University of Oklahoma, the first year of any other year of leave of absence from the University of Oklahoma, and years of University of Oklahoma employment after age 65 which follows TRS membership.

9. "Minimum Retirement Age" with Supplemental Benefits shall be 60 years for an employee who has completed 30 years employment with the University and 62 years for those who have completed at least 10 years employment.
10. "Prior Service Credit" shall be granted for:
  - a. Those years for which the employee was employed by the University of Oklahoma prior to July 1, 1943, and for which the employee has received prior service credit with TRS, and
  - b. A maximum of five years of prior service credit may be granted on the basis of one year's credit for each four full years (nine or more months) of full-time service at any accredited institution of higher education. Credit for service of fractions of **less** than four full years of service will not be considered.
11. "Supplemental Employment" means the employment of a retired member of TRS for a temporary period not to exceed the maximum per year established by regulations of TRS without affecting the member's status or benefits.
12. Salary for the purpose of determining current fringe benefits and for the establishment of retirement benefits shall consist only of those stipends paid from funds allocated to or collected by the University of Oklahoma Health Sciences Center, and expended through regular payroll procedures established by the Office of Administration and Finance of the University of Oklahoma Health Sciences Center and/or funds received directly by the individual such as career development award or fellowship; provided, however, that the inclusion of such award or fellowship must be specifically requested in advance in writing by the appropriate Dean and approved by the Provost, Health Sciences.

### Retirement Age

Normal Retirement: Any person employed by the University prior to September 2, 1977 who has not retired earlier will retire at the end of the fiscal year (July 1 - June 30) during which age 70 is reached; an Executive Officer or **Administrative** Officer will retire from his/her administrative position at the end of the fiscal year during which age 68 is reached. Effective September 2, 1977 and thereafter any employee of the University who has not retired earlier will retire at the end of the fiscal year during which age 65 is reached. Exceptions may be approved by the President in cases where a review has been made by an appropriate campus faculty-staff-administration committee, appointed by the President, on a year-to-year basis.

Optional Retirement: Any person who has completed 25 years of creditable service with the University may retire voluntarily on June 30 of any year

regardless of age. Such person, however, shall not be eligible to receive University supplemental benefits until July 1, following the date he/she becomes 62 years of age. Any person who has completed 30 years of service with the University may retire voluntarily on June 30 in any year regardless of age. Such person, however, shall not be eligible to receive University supplemental benefits until July 1, following the date he/she becomes 60 years of age.

Disability Retirement: Upon application of a member or receipt of an appropriate recommendation, any employee who has completed 10 years of University employment may be retired for disability provided that reasonable medical evidence has been presented indicating the individual is incapacitated for further performance of duty, that such incapacity is likely to be permanent and that the person should be retired. Disability retirement may be approved by the President after an appropriate campus faculty-staff-administration committee, designated by the President, has reviewed the matter. For faculty members, a recommendation for disability retirement will be processed through the budget committee of the department and the appropriate academic dean. Disability retirement shall be subject to reconsideration in any year prior to age 62. If evidence shows the individual so retired to be capable of performing satisfactory service in accordance with his/her education and training, retirement status may be removed.

#### Retirement Income Benefits

Social Security: All University employees who are not classified as students are covered by Social Security.

Teachers' Retirement System of Oklahoma: Membership in TRS is mandatory for faculty members, executive officers, professional staff, supervisory staff, managerial staff, administrative staff, and administrative officers. Membership is optional for service and operations staff employees. Further information may be obtained from the Office of Personnel Services or from Teachers' Retirement System of Oklahoma, P.O. Box 53524, Oklahoma City, Oklahoma.

The following is a brief summary of Plan 001 and Plan 002 approved by the Regents on September 2, 1976, and which are still in effect.

Retirement Addition: Faculty and staff members whose earnings (based upon contract or appointment) exceed \$9,000 per year and who are members of the Teachers' Retirement System of Oklahoma are required to participate in a retirement addition program (Plan 002) under Teachers Insurance and Annuity Association and College Retirement Equities Fund (TIAA-CREF) if they meet specified age, years of service or previous TIAA-CREF membership requirements. Some members participate in an earlier TIAA-CREF program (Plan 001). A complete description of the Retirement Addition and Plan 001/Plan 002 may be obtained from the Office of Personnel Services. University contributions to these two annuity programs are calculated in accordance with the methods described in the individual plans cited (Plan 001 and Plan 002). Plan 002 provides a projected schedule of increases in the rate of University contributions until a 15% level is scheduled to be achieved in the 1980-81 fiscal year, continuing thereafter at that 15% rate. Contributions will not be made on any amount of salary which would result in a contribution of \$1.00 or less per month. Enrollment is accomplished in the Office of Personnel Services where additional information which may be needed is available.

Supplemental Benefits: Benefits from primary Social Security, TRS, and Retirement Addition are combined with a Supplemental Benefit, as described below, to provide a retired employee with income protection for life. Regardless of the optional wage and salary level chosen by the member to determine TRS contributions, the benefits from TRS used in the computation of Supplemental Benefits will be based on the highest level of wages and salary upon which contributions may be made to TRS. To be eligible for Supplemental Benefits an employee must be a member of TRS.

1. A member who has served at least 10 years but less than 25 at the time of retirement will receive a Supplemental Benefit which, when added to his/her maximum annual retirement allowance from TRS, Primary Social Security and Retirement Addition, will provide a total benefit equal to the number of years of service times two percent of his/her average full-time annual salary rate for the highest five consecutive years of service, or \$15,000 per year, whichever is the lesser sum.
2. A member with 25 years of service at the time of retirement will receive from the University an amount which, when added to the member's maximum annual retirement allowance from TRS, Primary Social Security, and Retirement Addition will provide benefits equal to one-half his/her average annual salary rate for the highest salaried five consecutive years of service or \$15,000 per year, whichever is the lesser sum.

Supplemental For Disability Allowance: A member who retires or is retired for disability after 10 years of service will receive a Supplemental Benefit which, when added to his/her maximum annual disability retirement allowances from TRS, Primary Social Security and Retirement Addition, will provide a total annual allowance equal to the amount that the member would have received upon optional retirement based on his/her number of years of service and as if he/she were already age 62.

Supplemental Employment After Retirement: Following a review by an appropriate campus faculty-staff-administration committee and a showing of need for such service on a temporary basis, a member on retirement status may be approved for University employment on a part-time and/or temporary basis by the President and earn up to the maximum allowed by TRS during the fiscal year without affecting his/her retirement status and benefits. Earnings from the University beyond that amount will not be permitted.

Effect of Social Security and TRS Not Retroactive: Supplemental Benefits of members who have retired shall not be changed in any way because of changes in Social Security, TRS or Retirement Addition benefits received.

Other Retirement Benefits: Employees retiring in accordance with University retirement policy as described herein will be entitled to University-paid health insurance benefits for life. They shall also be issued an employee

identification card which shall entitle them to employment benefits associated with it, i.e., athletic tickets at reduced costs, use of University libraries, employee functions, Faculty Club, etc.

Regent White moved approval of the recommendation. The following voted yes on the motion: Regents Brett, Mitchell, Bailey, Replogle, Engleman, and White. The Chair declared the motion unanimously approved.

B. The Health Sciences Center

II. Academic

a. Personnel Actions

LEAVE OF ABSENCE:

Martin J. Fitzpatrick, Professor of Medicine, Tulsa, sabbatical leave of absence with half pay, February 1, 1977 through January 31, 1978 changed to sabbatical leave of absence with full pay, March 1, 1977 through September 1, 1977.

APPOINTMENTS :

David Lambuth Smith, M.D., Clinical Assistant Professor of Medicine, without remuneration, January 1, 1977 through June 30, 1977.

Donna Jean Kline Henderson, Clinical Assistant Professor of Nursing, without remuneration, April 1, 1977.

Patrick Dennis Fitzgerald, Clinical Assistant Professor of Ophthalmology, without remuneration, April 1, 1977.

Bill Bruce Crowell, M.D., Clinical Assistant Professor of Pathology, without remuneration, July 1, 1977.

Lewis E. Patrie, M.D., Clinical Assistant Professor of Psychiatry and Behavioral Sciences, without remuneration, April 1, 1977.

Arlene C. Cwikowski, Special Instructor in Cardiorespiratory Science, without remuneration, April 5, 1977.

John Aubrey McIntyre, M.D., Clinical Instructor in Medicine, without remuneration, January 1, 1977 through June 30, 1977.

James Frederick Tagge, M.D., Clinical Instructor in Medicine, without remuneration, January 1, 1977 through June 30, 1977.

Russell Dean Adams, Special Instructor in Radiologic Technology, without remuneration, May 1, 1977 through June 30, 1978.

Donald John Delzer, M.D., Visiting Lecturer in Radiological Sciences, without remuneration, May 1, 1977 through June 30, 1978.

NAME	TITLES	FTE INCOME CEILING	GUARANTEED TENURED	BASE SALARY NON-TENURED	PPP EARNINGS POTENTIAL	EFFECTIVE DATE	REMARKS
APPOINTMENTS:							
Lester Earl Krenn, no, M.D.	Assistant Professor of Family Practice, Tulsa	\$59,000		\$45,000	\$14,000	7-1-77 thru 6-30-78	F- N f+
Alan John Parkinson, Ph.D.	Adjunct Assistant Professor of Research Medicine Given additional title of Research Associate in <b>Microbiology</b> and Immunology	<b>WITHOUT REMUNERATION</b>				3-1-77	v v
		TO: 40,050		TO: 10,000	TO: 30,150	5-1-77 thru 6-30-77	
Merlin J. Kilbury, M.D.	Assistant Professor of Surgery, Tulsa	59,000		35,000	24,000	6-13-77 thru 6-30-78	
Charles Martin Roberts, P.D.	Research Associate in Microbiology and <b>Immunology</b>	23,600		15,600	8,000	3-4-77 thru 6-30-77	
CHANGES :							
Ray P. Cannon	<b>Assistant Professor of Surgery</b>	FROM: 55,000 TO: 58,527*		FROM: 20,000 TO: 23,527	FROM: 35,000 TO: 35,000	4-1-77 thru 6-30-77	*Temporary increase in FTE Ceiling
Wm. C. Elkins	Associate Professor of Surgery; Vice Head of Surgery; Chief, Section of Thoracic Surgery	FROM: 70,500 TO: 82,268*	FROM: 35,152 TO: 40,234		FROM: 33,348 TO: 42,034	4-1-77	*Temporary increase in FTE Ceiling
Wm. L. Frew, Jr.	Associate Professor of Surgery; Chief, <i>Division</i> of Oral Surgery; Assistant Professor of Oral Surgery	FROM: 69,000 TO: 71,865*		FROM: 41,212 TO: 44,077	FROM: 27,788 TO: 27,788	4-1-77 thru 6-30-77	*Temporary increase in FTE Ceiling
James R. Dever	Professor of Urology	74,000	FROM: 43,288 TO: 44,893		FROM: 30,712 TO: 29,107	6-19-77	<b>VA</b> Increase
Carl C. Gill	Assistant Professor of Surgery, Clinical Assistant Professor of Pediatrics	FROM: 55,000 TO: 55,600*		FROM: 25,000 TO: 25,600	FROM: 30,000 TO: 30,000	4-1-77 thru 6-30-77	*Temporary increase in FTE Ceiling
Ralph J. Kaplan	<b>Professor of Surgery</b>	FROM: 79,000 TO: 78,741*		FROM: 35,000 TO: 35,741	FROM: 43,000 TO: 43,000	4-1-77 thru 6-30-77	*Temporary increase in FTE Ceiling
J. Michael Kelly	Professor of Surgery; Chief, Section of Plastic Surgery	FROM: 79,500 TO: 83,481*		FROM: 40,000 TO: 43,981	FROM: 39,500 TO: 39,500	4-1-77 thru 6-30-77	*Temporary increase in FTE Ceiling
William D. Peyton	Assistant Professor of Surgery	FROM: 50,000 TO: 50,520*		FROM: 20,000 TO: 20,520	FROM: 30,000 TO: 30,000	4-1-77 thru 6-30-77	*Temporary increase in FTE Ceiling





NAME	TITLES	FTE IN = E CEILING	GUARANTEED BASF. SALARY TENURED	NON-TENURED	PPP EARNINGS POTENTIAL	EFFECTIVE DATE	REMARKS
Michael Pollay	Professor of Surgery; Chief, Section of Neurosurgery	FROM: \$79,500 TO: 80;242*		FROM: \$36,736 TO: 37,478	FROM: \$42,764 TO: 42,764	4-1-77 thru 6-30-77	*Temporary increase in FTE Ceiling
Hu-"- E. Robinson	Assistant Professor of Surgery	FROM: 57,000 TO: 60,632*		FROM: 32,000 TO: 35,632	FROM: 25,000 TO: 25,000	4-1-77 thru 6-30-77	*Temporary in FTE Ceiling
Frank C. Warman	Title changed from Assistant Professor to Clinical Assistant Professor of Psychiatry and Behavioral Sciences	FROM- 36,000 TO: WITHOUT REMUNERATION		FROM: 20,442	FROM: 15,558	3-12-77	

ADDITIONAL APPOINTMENT:

Stephen Frederick Canfield	Assistant Professor of Psychiatry and Behavioral Sciences	\$40,000		\$19,332	\$20,668	2-13-77 thru 6-30-77	
-------------------------------	---	----------	--	----------	----------	-------------------------	--

May 12, 1977

14428

CHANGES:

Kirstan Lee Bazzell, title changed from Associate in Research Medicine to Adjunct Assistant Professor of Human Ecology and Environmental Health, April 1, 1977 through June 30, 1977.

John Douglas Bruner, Clinical Instructor in Dental Services Administration, salary changed from \$4,000 for 5 months to without remuneration, April 1, 1977.

Mary Wanda Draper, title changed from Clinical Associate Professor to Associate Professor of Psychiatry and Behavioral Sciences, February 1, 1977 through June 30, 1977.

William H. Garnier, title changed from Clinical Associate Professor to Clinical Professor Emeritus of Ophthalmology, February 1, 1977.

Roderick E. McCallum, titles changed from Associate Professor of Microbiology and Immunology, College of Medicine, and Assistant Professor of Microbiology and Immunology, College of Dentistry, to Associate Professor of Microbiology and Immunology, Colleges of Medicine and Dentistry, and Adjunct Associate Professor of Oral Pathology, April 1, 1977.

John Williams Records, title changed from Clinical Professor to Clinical Professor Emeritus of Gynecology and Obstetrics, July 1, 1977.

Edgar W. Young, Jr., Associate Professor of Medicine and Associate Dean, Pre-Doctoral Education; given additional title of Clinical Associate Professor of Family Practice and Community Medicine and Dentistry, College of Medicine, April 1, 1977 through June 30, 1977.

TERMINATIONS:

Richard L. Mershon, Associate Professor of Oral Diagnosis and Radiology, July 1, 1978.

Razia S. Muneer, Associate in Research Biochemistry, April 1, 1977. Termination of Grant Funds.

Diane Lynell Schulz, Special Instructor in Radiologic Technology, April 2, 1977.

President Sharp recommended approval of the personnel actions listed above.

Regent Engleman moved approval of the recommendation. The following voted yes on the motion: Regents Brett, Mitchell, Bailey, Replogle, Engleman, and White. The Chair declared the motion unanimously carried.

President Sharp requested, and the Regents agreed, that the recommendation regarding tenure at the end of this section be removed without any action at this time.

President Sharp reported the following deaths:

Paul D. Erwin, Clinical Associate Professor of Surgery, on March 16, 1977.

Forrest M. Lingenfelter, Professor Emeritus of Surgery, on April 9, 1977.

### III. Finance and Management

#### a. Non-Academic Personnel Actions

##### APPOINTMENTS:

Marvin Everett Keele, Printing Service Manager, Print Shop, Health Sciences Center, \$13,500 for 12 months, April 25, 1977. Managerial Staff. Budget page 239, position 0001.

Calvin Whittaker, Auditor III, Internal Auditing, Health Sciences Center, \$14,100 for 12 months, April 18, 1977. Professional Staff. Budget page 8, position 0004. Transferred from Norman Campus without change in title or salary.

M. Jeanne Wright, Research Nurse, Department of Medicine, \$12,300 for 12 months, March 1, 1977. Professional Staff. Paid from C2113001.

##### CHANGES:

Teresa L. Avery, title changed from Staff Nurse to Nurse Clinician in Surgery, salary increased from \$11,012 for 12 months to \$15,600 for 12 months, February 1, 1977. Budget page 153, funds for increase transferred from C Budget.

Charles Davis, title changed from Programmer to Program Analyst, Data Processing, salary increased from \$11,760 to \$12,500 for 12 months, April 1, 1977. Professional Staff. Salary from A0000170.

Donald Ramsey, title changed from Program Analyst to Systems Analyst, Data Processing, salary increased from \$16,692 to \$17,000 for 12 months, April 1, 1977. Professional Staff. Salary from A0000170.

President Sharp recommended approval of the personnel actions listed above.

Regent Engleman moved approval of the recommendation. The following voted yes on the motion: Regents Brett, Mitchell, Bailey, Replogle, Engleman, and White. The Chair declared the motion unanimously carried.

#### b. Purchase of Audio-Visual Equipment

Two firms responded to our invitation to bid on furnishing and installing audio-visual equipment for the College of Nursing. The bids were evaluated by audio-visual technicians and the Purchasing Director. The recommendation is to accept the low bid as it meets all specifications. A tabulation of bids received is as follows:

Cory Motion Picture Equipment  
 Oklahoma City  
 System 1 - \$11,722.31  
 System 2 - 23,444.62 \$35,166.93

Atlantic Audio Visual  
 New York  
 System 1 - \$13,731.00  
 System 2     27,463.00 \$41,194.00

Funds are available in Budget Account #99470090, College of Nursing Equipment, to make this purchase.

President Sharp recommended that the audio-visual equipment be purchased from Cory Motion Picture Equipment in the amount of \$35,166.93.

Regent White moved approval of the recommendation. The following voted yes on the motion: Regents Brett, Mitchell, Bailey, Replogle, Engleman, and White. The Chair declared the motion unanimously carried.

c. Movable Equipment, College of Nursing Building

Request for bids for movable equipment for the College of Nursing Building were sent to thirty-four suppliers. Bids were received from eight suppliers. The bids have been reviewed by representatives of the College of Nursing, the project architect, the Health Sciences Center Purchasing Department, and Architectural and Engineering Services. The proposal is to accept the lowest bid offered that meets the specifications in almost all cases. In a few cases, the recommendation is to reject all bids or to accept a substitution which is lower in cost than the base bid product.

In one instance, Item 78, the recommendation is to buy an additional quantity of this chair for use in the building to replace a higher cost chair, Item 28. A tabulation of all bids and the list of companies receiving the invitation to bid was included in the agenda.

President Sharp recommended the following awards:

Fields-Downs-Randolph  
 Tulsa

Items 1, 2, 51 thru 59, 68, 99, 100, 101, 103 and Alternate 1	\$ 46,434.53
--	--------------

Scott-Rice

Items 3, and 3A thru 5 and 62	\$ 4,711.30
-------------------------------	-------------

Oklahoma City

Dan P. Scott and Sons, Inc.  
Tulsa

Items 6, 43 thru 50, 60, 61, 64, 65, 84 thru  
97, and 102 \$ 30,208.50

E and I Cooperative  
Dallas

Items 7 thru 20, 69 thru 83, 104, 105, Alternate  
6 and Additional order of line 78 items (184@  
\$112.27) \$ 97,411.21

Oklahoma Office Products  
Oklahoma City

Items 29 thru 39, 63, and 98 \$ 38,632.05

Modern Office Supply  
Oklahoma City

Items 40, 41, 42, 66 and 67 \$ 4,908.49  
\$222,306.08

President Sharp recommended also that all bids be rejected on Items 21 through 28, Alternate 2 through Alternate 5, and Alternate 7 and 8 primarily because prices for these items are above budgets.

Regent Mitchell said these bids were reviewed by the Facilities Planning Committee and the Committee concurs with President Sharp's recommendation. He moved approval. The following voted yes on the motion: Regents Brett, Mitchell, Bailey, Replogle, Engleman, and White. The Chair declared the motion unanimously carried.

#### d. Proposal, Contract, and Grant Report

A summary of proposals for contracts and grants for the Health Sciences Center for April, 1977, along with a list of all contracts executed during the same period of time on proposals previously reported was included in the agenda for this meeting.

President Sharp recommended that the President of the University or the President's designees be authorized to execute contracts on the pending proposals as negotiations are completed. The contracts budgets may differ from the proposed amounts depending upon these negotiations.

Regent Replogle moved approval of the recommendation. The following voted yes on the motion: Regents Brett, Mitchell, Bailey, Replogle, Engleman, and White. The Chair declared the motion unanimously carried.

## V. Operations and Physical Plant

### a. College of Pharmacy Building

In 1976, the Oklahoma State Regents for Higher Education approved a plan for the relocation of the College of Pharmacy from the Norman Campus to the Health Sciences Center. The College of Pharmacy moved to the Center during the summer of 1976.

Many functions of the College of Pharmacy are located in the houses vacated by the College of Health. Laboratory courses are being taught in common areas in the Basic Sciences Education Building and in houses modified to suit particular needs. As such, these plans are "short-term", and the need for a "permanent" home for the College of Pharmacy is obvious.

In 1974, a proposal was submitted to the Department of Health, Education, and Welfare for construction funds for a College of Pharmacy Building on the Health Sciences Center. This proposal was approved by the Federal Government, but funds were not available. The enabling legislation has been extended and the University has been invited to resubmit an application.

A grant application is now in preparation. A study of the current space requirements of the College has been completed. The proposed structure will contain a total area of 80,000 square feet. The total estimated cost of the project including construction, fixed laboratory equipment, movable equipment and fees is \$4,800,000. A grant of approximately \$3,700,000 is being requested. Matching funds of \$1,100,000 will be required to complete the funding package.

President Sharp recommended that the Capital Improvements Program for the Health Sciences Center be modified by increasing the scope and cost of the College of Pharmacy Building to 80,000 square feet and \$4,800,000 and that the Board of Regents authorize the submission of a grant application for approximately \$3,700,000 in Federal funds for the project.

Regent Mitchell reported the Facilities Planning Committee discussed this proposal at the meeting yesterday and concurs with the recommendation. He moved approval. The following voted yes on the motion: Regents Brett, Mitchell, Bailey, Replogle, Engleman, and White. The Chair declared the motion unanimously carried.

### b. Bids on College of Nursing Building Casework

Bids for the installation of a series of casework items including vertical blinds, drapery and hardware, millwork, chalk and presentation boards, lockers, venetian blinds, and wall-hung wardrobe units in the College of Nursing Building were received on May 5, 1977. A tabulation of all bids is as follows:

May 12, 1977

14433

<u>Proposals</u>	<u>Bids</u>
1. Base bid for all items of work	No bids
2. Vertical blinds	No bids
3. Drapery and hardware	
a. Sears Contract Sales	\$ 3,955.00
4. Millwork	
a. Harmon Construction Company (Note: Contract time, 120 days)	\$108,208.00
b. Oklahoma Fixture Company (Note: Contract time, 119 days)	\$ 64,336.00
5. Chalk and presentation boards	
a. Oklahoma Chalk Board	\$ 12,900.00
b. Specialties Plus (Note: Bid without installation)	\$ 1,574.00
c. Oklahoma Fixture Company (Note: Low bid as specified)	\$ 1,806.00
6. Lockers	No bid
7. Venetian blinds	
a. Rudy's Manufacturing and Sales (Note: Contract time, 45 days)	\$ 5,975.00
b. Sears Contract Sales (Note: Contract time, 60 days)	\$ 5,791.35
8. Wall-hung wardrobe units	
a. Oklahoma Fixture Company	\$ 1,094.00

The proposal is to accept the lowest bid that meets the specifications in each instance.

President Sharp recommended the following awards subject to a final review by the Department of Health, Education and Welfare:

Sears Contract Sales

a. Drapery and hardware	\$ 3,955.00
b. Venetian blinds	<u>5,791.35</u> \$ 9,746.35

Oklahoma Fixture Company

a. Millwork	\$ 64,336.00
b. Chalk and presentation boards	1,806.00
c. Wall-hung wardrobe units	<u>1,094.00</u> <u>\$67,236.00</u>
	\$76,982.35



Regent Mitchell. reported these bids were reviewed by the Facilities Planning Committee and the Committee concurs with the President's recommendation. He moved approval. The following voted yes on the motion: Regents Brett, Mitchell, Bailey, Replogle, Engleman, and White. The Chair declared the motion unanimously carried.

c. Acceptance of Project "J"

Representatives of the University, the project engineers, and the contractor have completed a final inspection of the portion of the Phase III Addition and Phase IV Addition to the Steam and Chilled Water Plant identified as Project "J". It was determined that the project is complete and ready for final acceptance.

This project includes the installation of steam and chilled water piping in a system of tunnels starting at a point in the main tunnel located east of the Biomedical Sciences Building and extending a distance of more than 1,000 feet to a point on the west side of the College of Nursing Building. When the building systems are complete, the new piping will serve both the Health Sciences Library and the College of Nursing Building. It also provides two points, one located near the intersection of Stonewall Avenue and Northeast 11th Street and the other located near the southwest corner of the College of Nursing Building for extensions of the system to serve future buildings located in the area east of Stonewall Avenue.

As a part of the College of Nursing Building additional work will be performed to finish the interior of the tunnel by the installation of lights, floor covering, wall surface treatment and graphics.

President Sharp recommended that Project "J", Phase III Addition and Phase IV Addition to the Central Steam and Chilled Water Plant be accepted as complete by the Board of Regents.

Regent Engleman moved approval of the recommendation. The following voted yes on the motion: Regents Brett, Mitchell, Bailey, Replogle, Engleman, and White. The Chair declared the motion unanimously carried.

d. Acceptance of Thrombosis-Coagulation Laboratory Renovation

A final inspection of the Thrombosis-Coagulation Laboratory renovation project was conducted on April 27, 1977. Concurrent with this inspection, the project plans and specifications were reviewed thoroughly and the project was determined to be complete.

In 1975, the University of Oklahoma Health Sciences Center received a \$3.2 million grant from the National Heart and Lung Institute of the National Institutes of Health to fund a five-year program project in thrombosis and related blood disorders. This program, directed by Dr. Fletcher B. Taylor, is divided into nine subprojects which include

both basic research and clinical applications. Researchers at the Health Sciences Center are studying blood proteins, which cause or are involved in clot formation. Clinical specialists from the Departments of Medicine and Surgery are studying patients with clotting disorders. The renovated laboratory provides part of the space required for the program.

President Sharp recommended that the Thrombosis-Coagulation Laboratory renovation be accepted as complete by the Board of Regents. -

Regent White moved approval of the motion. The following voted yes: Regents Brett, Mitchell, Bailey, Replogle, Engleman, and White. The Chair declared the motion unanimously approved.

e. Agreement - Pedestrian Corridor

An agreement has been proposed between the Board of Trustees of University Hospital and Clinics, the University Regents, and the Department of Institutions, Social and Rehabilitative Services pertaining to the construction, operation, and maintenance of a pedestrian-patient elevated walkway between University Hospital and Children's Memorial Hospital linking the Hospital's E-level and Children's Memorial Hospital, 3rd floor of Garrison Tower to provide access and improve programs. All three entities recognize the medical need for rapid, safe and efficient access to and from both hospitals and are desirous of improving the patient care programs and educational programs of the various entities.

DISRS has agreed to fund, construct, operate and maintain the pedestrian-patient elevated walkway between the University Hospital and Children's Memorial Hospital with the understanding that all three agencies agree to pay their portion, share and share alike with the other parties, of the operation, maintenance and repair of said walkway and if it is necessary to rebuild in whole or any portion of said walkway the expense of such rebuilding will be borne equally by all parties.

In order to construct the walkway, it is necessary for the University to convey to DISRS certain easements and right-of-ways. The easements are over, through, across and above the property located in the southeast quarter of Section 27, Township 12 North, Range 3 West of the Indian Meridian, Oklahoma County and includes the right of ingress and egress to and from the same.

President Sharp recommended approval of entering into the agreement with the Board of Trustees of the University Hospital and Clinics and the Department of Institutions, Social and Rehabilitative Services pertaining to the construction and maintenance of the pedestrian-patient elevated walkway as described above. The Health Sciences Center Committee of the Board concurs in this recommendation.

Regent Replogle moved approval. The following voted yes on the motion: Regents Brett, Mitchell, Bailey, Replogle, Engleman, and White. The Chair declared

the motion unanimously carried.

f. Lease to Veterans Administration Hospital for Parking

A lease has been proposed with the United States Government covering 500 parking spaces for the Veterans Administration Hospital personnel on property owned by the University of Oklahoma which is legally described as follows:

The west 20 feet of Lot 13, all of Lots 14 to 21 inclusive, all of Lots 27 to 39 inclusive, and the west 20 feet of Lot 40 in Block 3, Culbertson Heights Subdivision; and the west 20 feet of Lot 13, all of Lots 14 to 26 inclusive, and the north 63 feet of Lots 27 to 39 inclusive, and the north 63 feet of the west 20 feet of Lot 40 in Block 2, Culbertson Heights Subdivision, all in Oklahoma City.

This property is located between Everest Avenue and Lottie Avenue with Euclid Street on the north, and running south almost to Park Place.

The lease requires the Government to pay to the University the sum of \$3,000 per month for a period beginning April 13, 1977 and extending through March 31, 1978 during which time the Veterans Administration may not cancel the lease. The University of Oklahoma retains the right to terminate the lease at any time by giving at least 30 days notice in writing. The lease may be renewed at the option of the Government for the period April 1, 1978 through March 31, 1979 at \$36,000 per annum. Annual renewals are subject to availability of appropriation.

The lease contains the following additional provisions:

1. The University will enclose the leased area with a chain link security fence, provide one card activated entrance gate, one automatic exit gate and two pedestrian gates. A concrete wheel stop not exceeding 5½ inches in height will be provided. Two shelters will be provided within the confines of the area.
2. A shuttle service will be provided by the University to take VA employees from the parking lot directly to the hospital.
3. The Government will have the right to install a security guard shelter and maintain security personnel as deemed necessary.
4. The University will provide security patrol equal to that provided other parking areas under our jurisdiction.
5. The University will provide the necessary supplies to operate the parking system described in the agreement, including the initial issuance of vehicle decals, parking lot gate cards, parking registration forms and other supplies necessary to maintain the system. The VA Hospital will reissue all gate cards and vehicle decals as appropriate and reimburse the University the current cost of those supplies.

President Sharp recommended approval of entering into an agreement with the United States Government for the lease of the above described property for a parking facility for the Veterans Administration Hospital. The Health Sciences Center Committee of the Board concurs in this recommendation.

Regent White moved approval. The following voted yes on the motion: Regents Brett, Mitchell, Bailey, Replogle, Engleman, and White. The Chair declared the motion unanimously carried.

g. Report on Major Capital Improvements Projects

As shown on the following page a report was presented to the Regents on major capital improvements projects under construction and in various stages of planning on the Health Sciences Center Campus. No action was required.

VII. University Relations

a. Trustees for University Hospital

The Board of Regents of the University of Oklahoma appoint three Trustees to the Board of the University Hospital and Clinics. The terms of the current Regents' Trustees expire on June 30, 1977.

President Sharp recommended the reappointment of the following to serve on the University Hospital and Clinics Board of Trustees for the period July 1, 1977 through June 30, 1978:

Mr. Jimmy Cole

Dr. Jay P. Cannon

Dr. Philip E. Smith

Regent Mitchell moved approval of the recommendation. The following voted yes on the motion: Regents Brett, Mitchell, Bailey, Replogle, Engleman, and White. The Chair declared the motion unanimously approved.

C. Academic (Norman Campus)

I. Personnel Actions

LEAVES OF ABSENCE:

Robert E. Bell, George Lynn Cross Research Professor of Anthropology, sabbatical leave of absence with full pay, January 16, 1978 through May 31, 1978. To visit New Zealand, France and England to research developments in archeology and to complete a volume on Oklahoma archeology.

James A. Constantin, David Ross Boyd Professor of Business Administration, sabbatical leave of absence with full pay, September 1, 1977 through January 15, 1978. For purposes of study, research and writing.

Glenn R. Snider, Regents Professor and Professor of Education, sabbatical leave of absence with full pay, January 1, 1978 through June 30, 1978. To complete research and writing tasks in areas of educational leadership and public service functions of state universities.

Duane H. D. Roller, McCasland Professor of the History of Science; Curator, History of Science Collections; and Assistant Director for Special Collections, University Libraries, sabbatical leave of absence with full pay, September 1, 1977 through January 15, 1978. For purposes of study and research in the history of Greek Science and travel.

James H. Abbott, David Ross Boyd Professor of Modern Languages, sabbatical leave of absence with full pay, January 16, 1978 through May 31, 1978. For purposes of research in Spain.

Seymour Feiler, David Ross Boyd Professor of Modern Languages, sabbatical leave of absence with full pay, January 16, 1978 through May 31, 1978. To pursue research in France.

Gail Boyd de Stwolinski, David Ross Boyd Professor of Music, sabbatical leave of absence with full pay, January 16, 1978 through May 31, 1978. For purposes of research.

Leon Stanley Ciereszko, Professor of Chemistry, sabbatical leave of absence with half pay, January 16, 1978 through May 31, 1978. To conduct experiments on coral reef organisms and collect material for research studies.

Francis J. Schmitz, Professor of Chemistry, sabbatical leave of absence with full pay, January 16, 1978 through May 31, 1978. For purposes of research and writing.

James E. Hibdon, Professor of Economics, sabbatical leave of absence with half pay, September 1, 1977 through May 31, 1978. Research concerning health issues at Public Health Service and research with the Economic Development Administration.

Benjamin J. Taylor, Professor of Economics, sabbatical leave of absence with full pay, January 16, 1978 through May 31, 1978. For the purpose of research and writing.

Gerald T. Kowitz, Professor of Education, sabbatical leave of absence with full pay, July 1, 1977 through December 31, 1977. To prepare a publication on one aspect of the emerging factors which will form the profession of education in years ahead.

John Donald Pulliam, Professor of Education, sabbatical leave of absence with full pay from January 1, 1978 through June 30, 1978. To extend knowledge and improve skills in the field of educational futures and complete a manuscript.

ARCHITECTURAL AND ENGINEERING SERVICES  
THE UNIVERSITY OF OKLAHOMA

MAJOR CAPITAL IMPROVEMENTS PROGRAM

PROGRESS REPORT, MAY, 1977

PROJECTS UNDER CONSTRUCTION

Project	CM <sup>3</sup> Priority No.	Architect	Contractor	Contract Award Date	Original Adjusted Completion Date	Original Current Contract Amount	Status (% complete)	Sources of Funds
HEALTH SCIENCES CENTER								
College of Nursing Building	2	Murray, Jones, Murray	Harmon Construction Co.	10/16/75	07/04/77	<u>3,635,000</u> 3,742,148	94 %	Bond Funds Grant, DHEW
Corridor/Bridge	7	Wright & Selby	The Constructors Co., Inc.	03/20/76	11/23/76 <u>01/22/77</u>	<u>273,600</u> 279,020	92 %	Bond Funds Grant, DHEW
Health Sciences Library	1A	Binnicker Associates	J.J. Cook & Associates	04/30/76	07/29/78	<u>5,152,455</u> 5,356,134	56 %	Bond Funds Grant, DHEW Gifts
College of Nursing Building Elevator #3 and #4	--	Murray, Jones, Murray	Montgomery Elevator Co.	07/22/76	08/11/77	119,823	95 %	Bond Funds, Grant, DHEW
Steam and Chilled Water Plant, Phase III & IV, Project "J"	--	Carrahan, Thompson & Delano	Kay Engineering Company- Oklahoma	10/14/76	03/12/77	193,250	99 %	Revenue Bonds
Thrombosis-Coagulation Laboratory	--	A & E Services	OUHSC Site Support	--	01/15/77 <u>03/15/77</u>	55,000	99 %	Grant

ARCHITECTURAL AND ENGINEERING SERVICES  
THE UNIVERSITY OF OKLAHOMA

MAJOR CAPITAL IMPROVEMENTS PROGRAM

PROGRESS REPORT, MAY, 1977

PROJECTS IN VARIOUS STAGES OF PLANNING

Project	CMP Priority No.	Architect	Contract or Letter	Estimated Cost	Status
HEALTH SCIENCES CENTER					
Health Sciences Library	1B	A & E Services	--	411,381	Plans for the movable equipment are being prepared
College of Pharmacy Building	4	A & E Services	--	3,915,000	An application requesting a Federal construction grant will be resubmitted
Multi-Purpose Building	--	A & E Services	--	--	A feasibility study has been completed and is undergoing review
Dental Clinics, Site Development	10	McCune & McCune	C12/13/73	288,125	Preliminary plans are being prepared
Biomedical Sciences Building Site Development	7	Wright & Selby	C10/12/72	263,750	Inactive
College of Health Building Auditorium Renovation	--	Locke, Wright & Foster	--	317,000	Inactive
College of Nursing, Fixed Equipment	2	Murray Jones Murray	C05/09/75	179,000	Final plans and specifications have been completed
Dental Clinics, Landscape Plan	10	Thomas Roberts & Associates	--	149,375	Preliminary plans are being prepared
Biomedical Sciences Building, Landscape Plan	7	"	--	179,250	" "
College of Nursing Landscape Plan	2	"	--	179,250	" "



Jack L. Kendall, Professor of English, sabbatical leave of absence with half pay, January 16, 1978 through May 31, 1978 and September 1, 1978 through January 15, 1979. For purposes of research and writing.

Sidney Devere Brown, Professor of History, sabbatical leave of absence with half pay, September 1, 1977 through May 31, 1978. For purposes of writing and research travel to Japan.

Gene Levy, Professor of Mathematics, sabbatical leave of absence with full pay, July 1, 1977 through December 31, 1977. To study and prepare for returning to full-time teaching.

Sybrand Broersma, Professor of Physics, sabbatical leave of absence with full pay, January 16, 1978 through May 31, 1978. For purposes of research.

Wayne A. Chess, Professor of Social Work, sabbatical leave of absence with half pay, September 1, 1977 through May 31, 1978. For purposes of research and writing.

Tillman J. Ragan, Associate Professor of Education, sabbatical leave of absence with full pay, July 1, 1977 through December 31, 1977. To pursue research and professional development activities.

James Marion Goodman, Associate Professor of Geography, sabbatical leave of absence with half pay, January 16, 1978 through May 31, 1978. To continue studies of Indian groups of the Southwest.

Karlen Mooradian, Associate Professor of Journalism, sabbatical leave of absence with full pay, September 1, 1977 through January 16, 1978. To complete the writing of a book.

Charles F. Gettys, Associate Professor of Psychology, sabbatical leave of absence with half pay, September 1, 1977 through May 31, 1978. For purposes of research.

W. Alan Nicewander, Associate Professor of Psychology, sabbatical leave of absence with half pay, September 1, 1977 through May 31, 1978. For purposes of study and research.

Gary D. Schnell, Associate Professor of Zoology, sabbatical leave of absence with half pay, September 1, 1977 through May 31, 1978. To pursue a program of learning, research and scholarship.

William J. Horwitz, Assistant Professor of Classics, sabbatical leave of absence with full pay, September 1, 1977 through January 15, 1978. For purposes of study, writing and travel.

Richard T. Wallis, Assistant Professor of Classics, sabbatical leave of absence with full pay, January 16, 1978 through May 31, 1978. For completion of a philosophical commentary on two treatises by Plotinus on the soul.

Jiri Zidek, Assistant Professor of Geology and Curator of Vertebrate Paleontology, Stovall Museum, sabbatical leave of absence with full pay, January 1, 1978 through June 30, 1978. To work on preparation of a volume for the Fossilium Catalogus.

Andrew J. Heisserer, Assistant Professor of History, sabbatical leave of absence with full pay, January 16, 1978 through May 31, 1978. For purposes of research and writing.

A. B. Schwarzkopf, Assistant Professor of Mathematics, sabbatical leave of absence with full pay, January 16, 1978 through May 31, 1978. To refresh and expand knowledge and experience.

Carol Ann Beesley, Assistant Professor of Art, leave of absence without pay, September 1, 1977 through May 31, 1978. Received a National Endowment for the Humanities Fellowship in Residence for College Teachers.

Barbara Ann Nelson, Assistant Professor of Education, leave of absence without pay, September 1, 1977 through August 31, 1978. Serving an internship at the California School of Professional Psychology.

Jay S. Fein, Assistant Professor of Meteorology, leave of absence without pay, September 1, 1977 through May 31, 1978. To extend activities with National Science Foundation.

#### APPOINTMENTS:

Thomas Ray Mason, J.D., Visiting Associate Professor of Law, rate of \$27,272 for 12 months, August 1, 1977 through June 30, 1978. 1977-78 Budget.

Patricia Ann Self, Ph.D., Associate Professor of Psychology with tenure, \$18,000 for 9 months, September 1, 1977. 1977-78 Budget.

David Franklin Marten, Ph.D., Assistant Professor of Chemistry, \$15,000 for 9 months, September 1, 1977 through May 31, 1978. 1977-78 Budget.

Charles Robert McClure, Assistant Professor of Library Science, \$16,750 for 9 months (if Ph.D. not completed by September 1, 1977, title to be changed to Acting Assistant Professor at \$16,250), September 1, 1977 through May 31, 1978. 1977-78 Budget.

Bernice Colleen McKibben, Ph.D., Assistant Professor of Library Science, \$16,750 for 9 months, September 1, 1977 through May 31, 1978. 1977-78 Budget.

Douglas Wayne Mock, Ph.D., Assistant Professor of Zoology, \$14,000 for 9 months, January 1, 1978 through May 31, 1978. 1977-78 Budget.

Philip Doren Lujan, J.D., Director, American Indian Studies, \$15,300 for 9 months, September 1, 1977 through May 31, 1978. 1977-78 Budget.

#### CHANGE:

Martin C. Jischke, Professor of Aerospace, Mechanical and Nuclear Engineering; appointed to a four-year term as Director, School of Aerospace, Mechanical and Nuclear Engineering, September 1, 1977 to September 1, 1981.

RESIGNATIONS:

Alfred J. Weinheimer, Professor of Chemistry, September 1, 1977. To accept position at the University of Houston as Professor of Medicinal Chemistry.

Robert Ross Wright III, Professor of Law, June 1, 1977. To accept position at the University of Arkansas as Professor of Law.

Samuel A. Kirkpatrick, Professor of Political Science, Director of the Bureau of Government Research, and Director of Scholar-Leadership Enrichment Program, September 1, 1977. To accept position as Professor and Head of the Department of Political Science at Texas A&M University.

Gerald L. Grotta, Associate Professor of Journalism, June 1, 1977. To accept position at RMH Research, Inc. as Vice President for Media Research.

William G. Sorenson, Assistant Professor of Botany and Microbiology, June 1, 1977.

Michael J. Pavelich, Assistant Professor of Chemistry, August 1, 1977. To accept position at Colorado School of Mines.

President Sharp recommended approval of the personnel actions listed above.

Regent Mitchell moved approval of the recommendation. The following voted yes on the motion: Regents Brett, Mitchell, Bailey, Replogle, Engleman, and White. The Chair declared the motion unanimously carried.

President Sharp reported the death of:

Carl T. Almquist, Professor Emeritus of Electrical Engineering, on April 9, 1977.

## II. Programs

### a. Linguistics Program - Bachelor of Arts

A new interdepartmental program in linguistics leading to the degree Bachelor of Arts has been proposed. Every year a number of students at the University express an interest in the field of linguistics. These students are of two kinds: those who want to acquire skills in linguistics analysis to help them in their own majors, and those who express an interest in pursuing a major in linguistics. Individual departments such as Speech Communication, Anthropology and Modern Languages have responded to the first kind of student (and to changing demands of the fields that they represent) by hiring linguists, but individual departments have limited resources and they cannot afford to offer sufficient courses to give either the breadth or the depth necessary to really satisfy the needs of their students. In addition, because departments typically teach to their own constituency and because there is a certain core subject matter to the field of linguistics which all students must have, a considerable duplication of effort is necessary if each department is offering linguistics courses to its own students. In summary the needs of the first type of student

are being met with only a limited amount of success, and that at the price of efficiency. The second type of student is not being cared for at all. Students who are interested in a linguistics major must go out of state to satisfy their need. This proposed interdepartmental program in linguistics furnishes the structure for an integrated progressive curriculum which will not only satisfy a major in linguistics but which will allow the needs of other students to be met more completely and efficiently.

There are pragmatic needs for this program in the Oklahoma society. The most imperative pragmatic area has to do with Native Americans. A number of the Oklahoma tribes are faced with the real danger of losing their native languages since the primary speakers of those languages are elderly and often in precarious health. It is quite probable that with the death of these members in a few years these languages will be gone. Lately, however, some of the tribes have begun a movement to record their languages and to begin programs to teach them to their younger members. This is a big job and impossible without technical assistance. There are only a handful of people in Oklahoma, including faculty at the University of Oklahoma, who are capable of assisting and few of these have large amounts of time to spend at this work. This program can materially assist in satisfying this need by training Oklahomans, Native American or otherwise, to begin this very important work.

In September 1977 there will be six primary faculty members from three departments who are qualified to teach the required courses and many of the linguistically oriented electives. It is projected that no new faculty will be required within the first five years for this program.

Current academic space and equipment is sufficient for implementation of this program. Current library resources will support immediate implementation of the program, but the committee which developed the proposal will work diligently to improve holdings within current acquisition budgets.

President Sharp recommended approval of the new interdepartmental program in linguistics leading to the degree Bachelor of Arts. This program is subject to approval of the Oklahoma State Regents for Higher Education.

Regent Engleman moved approval of the recommendation. The following voted yes: Regents Brett, Mitchell, Bailey, Replogle, Engleman, and White. The Chair declared the motion unanimously carried.

#### b. Real Estate Program

The College of Business Administration has proposed the establishment of a new educational program in real estate leading to the degree Bachelor of Business Administration.

The increasing complexity of every facet of real estate operations requires persons who are capable of analytical thinking and accurate decision-making. Technologically, legally, financially, and logistically the business of real estate has become much more sophisticated and demanding. Society needs persons who are

educated in dealing with real estate problems in (1) the traditional real estate professions, i.e. land developers, building contractors, mortgage bankers, appraisers, brokers, and property managers, (2) in staff positions in non-real estate business, i.e. site selection analysis, lease negotiators, land acquisition and disposition specialists, and property managers, and (3) in public service positions, i.e. tax assessors, right-of-way condemnation specialists, environmental impact experts, and planners. A student majoring in real estate in our College of Business Administration would be prepared to make a meaningful contribution toward meeting these societal needs.

Our College of Business Administration is currently committing a substantial amount of resources to real estate education. The College presently offers courses in Real Estate Principles, Real Estate Appraising, Real Estate Financing, Real Property Law, Property Insurance, Urban Economics, Regional Economics, and Logistics Management. This commitment, however, is not recognized by the general public, industry, and other universities because this teaching and research is done under the headings of Finance, Marketing, Economics and Business Law. A real estate major in our College of Business Administration would readily identify the existing commitment of the College to the study of real estate. With a real estate major the College would be in a much better position to solicit research and educational funds from sources outside of the University.

A designated real estate major is very important for students who desire to study real estate and pursue a career in some area of real estate. Presently these students are Finance, Marketing, Management or Accounting majors. This is unfair to these students for two reasons. First, the job market for persons in real estate is very fragmented and informal and potential employers of real estate students do not recruit at the University because there is not a real estate major. Secondly, even if a student has taken all of the real estate courses at the University of Oklahoma he cannot be recognized or identified as a real estate major and therefore, he cannot compete in the job market as a bona fide real estate major.

Essentially the need for a real estate major at the University reduces to a "packaging program". It is necessary to package and identify the existing courses in real estate so the institution can better meet the needs of the students and the students can better meet the needs of industry. No additional faculty, facilities, library materials or other resources are required to implement the program.

President Sharp recommended approval of a new educational major in real estate leading to the degree Bachelor of Business Administration effective with the Fall semester 1977. This is subject to approval of the Oklahoma State Regents for Higher Education.

Regent White moved approval of the recommendation. The following voted yes on the motion: Regents Brett, Mitchell, Bailey, Replogle, Engleman, and White. The Chair declared the motion unanimously carried.

c. Classics Program - Bachelor of Arts

A proposal has been submitted that the current Latin and Greek programs be merged in a new Classics program leading to the degree Bachelor of Arts.

The program proposed conforms to trends that are currently prevailing in American higher education in the field of classical studies. These trends in turn reflect the needs and interest of current and, insofar as they may be projected, future generations of college and university students with respect to their knowledge of our Greco-Roman heritage and its significance for understanding contemporary western civilization and cultures.

This restructured Classics program will integrate classical studies more cohesively with other related subjects and will offer students expanded opportunities to pursue their studies of the subjects involved. At the same time this program is instituted, the University will discontinue two more narrowly focused majors in Latin and Greek.

The program change proposed will be carried out entirely with existing faculty, current space and equipment, and library materials presently available.

President Sharp recommended approval of the new educational program in Classics leading to the degree Bachelor of Arts. This program is subject to approval of the Oklahoma State Regents for Higher Education.

Regent Engleman moved approval of the recommendation. The following voted yes on the motion: Regents Brett, Mitchell, Bailey, Replogle, Engleman, and White. The Chair declared the motion unanimously carried.

d. Resolution of Commendation - Chemical Engineering

WHEREAS, the University of Oklahoma has always strived to provide the best education possible for the students it serves; and

WHEREAS, the University continues to seek ways to make its academic programs ever more attractive; and

WHEREAS, the Chemical Engineering programs in the University of Oklahoma's School of Chemical Engineering and Materials Science recently have been rated in an evaluation prepared for The Chemical Engineering Education Journal of the American Society for Engineering Education as fifth in the nation from among more than 150 colleges and universities; now, therefore,

BE IT RESOLVED, that the members of the Board of Regents of the University of Oklahoma, on behalf of the student body, faculty and staff of the University and citizens throughout the State, express great pride in the accomplishments of the School of Chemical Engineering and Materials Science, its Dean, Dr. William R. Upthegrove, its Director, Dr. Samir Sofer, their colleagues, and the students of the School, and salute them for their contribution to the overall mission of the University.

President Sharp recommended adoption of the above resolution.

Regent Engleman moved approval of the recommendation. The following voted yes on the motion: Regents Brett, Mitchell, Bailey, Replogle, Engleman, and White. The Chair declared the motion unanimously carried.

D. Finance and Management (Norman Campus)

I. Non-Academic Personnel Actions

a. Educational and General, Special Agency, and Service Units

CHANGES:

David A. Burr, title changed from Vice President for University Development to Vice President for University Relations and Development, July 8, 1977.

Doris Donwerth, title changed from Accountant II Trainee to Accountant II, Accounting Services, salary increased from \$10,800 to annual rate of \$11,300 for 12 months, April 6, 1977. Funds for increase from Budget page 11, position 3.

Candace Schober Greene, Administrative Assistant, Stovall Museum; given additional title Curatorial Associate, Stovall Museum, February 23, 1977.

Oscar B. Jackson, title changed from Student Personnel Analyst to Minority Recruiter, Personnel Services, salary changed from \$5.38 per hour, .49 time, to \$11,200 for 12 months, full time, May 7, 1977. Budget page 24, position 6.

Virginia N. Lee, title changed from Assistant Manager to Acting Manager, University Graphic Service, salary increased from \$9,600 to \$11,600 for 12 months, January 31, 1977. Administrative Staff. Graphic Service funds available.

Phil Terry Newkumet, Associate Director, Center for Student Development, and Coordinator of Veterans' Affairs, annual salary rate changed from \$16,400 to \$16,000 for 12 months plus \$100 per month, March 1, 1977 through June 30, 1977. Correction of action taken at April meeting.

David W. Smeal, title changed from Assistant Director for Broadcast Services to Assistant Director, Media Information Broadcast Services, Office of Media Information, March 29, 1977. Managerial Staff.

RESIGNATIONS:

James F. Oliver, Assistant Manager and Accountant III, Accounting Services, April 6, 1977.

Kenneth E. Schuerman, Assistant Director of Development, April 27, 1977.

President Sharp recommended approval of the personnel actions listed above.

Regent Engleman moved approval of the recommendation. The following voted yes on the motion: Regents Brett, Mitchell, Bailey, Replogle, Engleman, and White. The Chair declared the motion unanimously carried.

b. Grants and Contracts

RESIGNATIONS:

Jimmy H. Brewer, Senior Course Moderator, FAA Management Training School, and Adjunct Instructor in Political Science, May 12, 1977.

Bradley T. Farnsworth, Research Assistant II, Center for Economic and Management Research, May 15, 1977.

President Sharp recommended approval of the personnel actions listed above.

Regent Engleman moved approval of the recommendation. The following voted yes on the motion: Regents Brett, Mitchell, Bailey, Replogle, Engleman, and White. The Chair declared the motion unanimously carried.

VI. Purchases

a. Lease/Purchase of Additional Memory for Computer

The IBM 370/158J Computer at Merrick Computer Center has an attached Intel Memory Unit. An additional 1,000,000 bytes of memory are now required and this must be compatible with one of the two existing systems. Accordingly, bids were circulated to only IBM and Intel.

The cost of the purchase will be charged to University Computing Services Account 147-110.

Bids were received as follows:

	<u>IBM Corp.</u>	<u>Intel Corp.</u>
Total Cash Price	\$99,000.00	\$53,070.00
Payment Schedule:	<u>Payment</u>	<u>Payment</u>
Initial Payment	Not Submitted	\$14,515.00
2nd Payment	Not Submitted	\$15,000.00
3rd Payment	Not Submitted	\$15,000.00
4th Payment	Not Submitted	\$15,000.00
Maintenance Rate	\$194.60/month	\$95.00/month



A summary of the above bid breakdown is as follows:

<u>Vendor</u>	<u>Purchase Price</u>	<u>5 Year Monthly Maintenance</u>	<u>Interest</u>	<u>Total Five Year Cost</u>
Intel	\$53,070.00	\$ 5,700.00	\$6,445.00	\$ 65,215.00
IBM	\$99,000.00	\$11,676.00	Not Submit.	\$110,676.00*

\*Plus Interest

The low bid of Intel is acceptable to the Director of Computing Services.

President Sharp recommended that the Board of Regents approve the award of a purchase order to Intel for the lease/purchase of 1,000,000 additional bytes of computer memory.

Regent White moved approval of the recommendation. The following voted yes on the motion: Regents Brett, Mitchell, Bailey, Replogle, Engleman, and White. The Chair declared the motion unanimously carried.

b. Offset Printing Paper for University Press

Bids have been circulated to five companies for eight items of offset printing paper for the University Press. The cost of the purchase will be charged to University Press Account 147-309.

A bid was received from only one company as follows:

Western Paper Company  
Oklahoma City  
Delivery: 30 days Terms: 2% \$40,609.00

Western Paper Company is one of the two Oklahoma distributors for Warren Paper Company. In the past, we have received bids from both companies, with the bids submitted being almost identical. The net result of the Western Paper Company bid represents an increase of 2% over a bid on the same items one year ago. When considering the inflation during the interim, the bid is considered to be fair and reasonable. The 2% cash discount will be realized and reduce the cost of the purchase by \$812.00 to \$39,797.00. The Director of Printing concurs in the award of this bid to Western Paper Company.

President Sharp recommended that the Board of Regents approve the award of a purchase order to Western Paper Company in the amount of \$40,609.00 for eight items of offset printing paper.

Regent Engleman moved approval of the recommendation. The following voted yes on the motion: Regents Brett, Mitchell, Bailey, Replogle, Engleman, and White. The Chair declared the motion unanimously carried.

## c. Offset Paper for Journalism Press

Bids were circulated to six vendors for white offset paper as follows:

40,000 lbs. of 29" and 14½" width  
 27 rolls of 36" width  
 18 rolls of 18" width

Payment will be made from Journalism Press Account 177-302.

Bids were received from two companies:

1. Carpenter Paper Company  
 Oklahoma City

Bidding South Shore Offset

Items 1)	\$24.70 cwt	Total	\$20,639.23
2)	\$24.70 cwt	Less 2% discount	- 412.78
3)	\$24.70 cwt	Total Amount	\$20,226.45

The total was based on an estimate of 84,000 lbs. and subject to change with actual weight shipped.

2. Capital Paper Company  
 Oklahoma City

Items 1)	\$26.15 cwt (29")	\$26.65 cwt (14½")	\$22,500.00
2)	\$26.15 cwt		
3)	\$26.15 cwt		

The total was based on an estimate of 85,000 lbs.

The Director of Printing indicates that the Carpenter Paper Company bid is acceptable.

President Sharp recommended that the Board of Regents approve the award of a purchase order to Carpenter Paper Company in the estimated amount of \$20,226.45.

Regent White moved approval of the recommendation. The following voted yes on the motion: Regents Brett, Mitchell, Bailey, Replogle, Engleman, and White. The Chair declared the motion unanimously carried.

## d. Bread and Bread Products

Bids have been received for an exclusive contract to furnish estimated quantities of 13 items of bread and bread products to the University. Bids were requested on both a six months and a 12 months basis for the period beginning July 1, 1977 on the estimated quantities required for these periods.

Payment will be made from various University Food Service Departments using the contract.

Bids received are:

	<u>Six Months</u>	<u>Twelve Months</u>
ITT Continental Baking Company Oklahoma City	\$15,164.00	\$30,328.00
Rainbo Baking Company Oklahoma City *All or None Bid	\$14,845.00*	\$31,690.00*

Since it is likely that the prices of bread products will continue to rise, it would be in the best interest of the University to have a firm fixed price contract for the next 12 months. Therefore, the evaluation was made on the basis of the 12 month bids. The low bid by ITT Continental is acceptable to the three major Food Service Directors.

The facilities of ITT Continental were inspected by Mr. Dan Guyer, University Sanitarian, and meet the University's requirements.

Bids were sent only to three companies because historically these have been the only companies which have responded to this bid. All other companies in this area have failed to respond to at least the four previous bids. In addition to those responding a bid was sent to Bond Baking Company.

President Sharp recommended that the Board of Regents approve the issuance of a Purchase Order in the estimated amount of \$30,328.00 for the next fiscal year requirements for bread and bread products to ITT Continental Baking Company of Oklahoma City, the lowest acceptable bidder.

Regent Mitchell moved approval of the recommendation. The following voted yes on the motion: Regents Brett, Mitchell, Bailey, Replogle, Engleman, and White. The Chair declared the motion unanimously carried.

Regent Replogle said he hoped that in the future we would not limit our solicitation of bids for these items to only three companies, but that we would give other firms the opportunity to bid. President Sharp indicated that he will instruct our Purchasing Department to that effect.

e. Orange Juice and Grape Juice

Bids were circulated to 13 vendors to secure a contract to furnish orange juice and grape juice with dispensers for the fiscal year July 1, 1977 through June 30, 1978. A price per case and a price per ounce (reconstituted) were requested.

Payment will be from Housing Accounts 172-101, 172-110, and 172-111.

Only two vendors returned completed bids. These are:

The Coca-Cola Company - Food Division  
Yukon, OK

750 case Orange Juice 6/96 oz. (per ounce reconstituted \$.0124)	34.00/cs.	\$25,500.00
400 case Grape Juice 12/32 oz. (per ounce reconstituted \$.0104)	16.00/cs.	<u>6,400.00</u>
	Total	\$31,900.00

Mid-Central Fish & Frozen Foods  
Oklahoma City

750 case Orange Juice 6/96 oz. (per ounce reconstituted \$.0141)	37.50/cs.	\$28,125.00
400 case Grape Juice 6/46 oz. (per ounce reconstituted \$.0148)	24.50/cs.	<u>9,800.00</u>
	Total	\$37,925.00

The Coca-Cola Company has added a clause to their bid that if there are unforeseen circumstances, the company reserves the right to increase prices with a 30 day written notice. The intent of this clause is for protection against any freeze which might occur to next winter's crops, thereby driving the price up. Mid-Central also added a similar condition. The University will reserve the right to cancel any resulting contract if any such increase occurs and is not acceptable.

The Coca-Cola Company bid is acceptable to the Food Service Director.

President Sharp recommended that the Board of Regents approve a contract with The Coca-Cola Company for the period of July 1, 1977 through June 30, 1978 in the amount of \$31,900.00 for orange juice and grape juice.

Regent Engleman moved approval of the recommendation. The following voted yes on the motion: Regents Brett, Mitchell, Bailey, Replogle, Engleman, and White. The Chair declared the motion carried.

f. Front-Loader Refuse Truck

Bids were circulated for one front-loader refuse truck for use by the Physical Plant. The purchase will be charged to Physical Plant Account 147-201 (\$16,500) and Sale of Surplus Property Account 179-121 (\$21,000).

Bids were requested with and without trade-in.

Bids were received from three vendors as follows:

Industrial Disposal Supplies, Inc.  
Oklahoma City

With C8000 Ford	\$37,500.00
CO-1950 International	\$37,000.00

Trade-In \$4,000.00

Dumpster Southwest Company  
Knoxville, Tenn.

Total Cost \$39,914.21

Trade-In \$2,500.00

Murphy Machinery Company  
Oklahoma City

Total Cost \$40,995.00

Alternate rear Axle & 12.00 x 20 16 ply with 81 U Rim	\$41,105.00
---	-------------

Trade-In None

The low bid has been reviewed by Physical Plant and the alternate with the C8000 Ford Chassis at \$37,500 is acceptable to them. There is more flexible and responsive repair part support for the Ford Chassis versus the International Chassis. The trade-in price of \$4,000.00 is not acceptable. The unit will be used temporarily and placed under sale bid at a future date.

President Sharp recommended that the Regents approve the award of a Purchase Order in the amount of \$37,500.00 to Industrial Disposal Supply, Inc. for the purchase of the front-loader refuse truck.

Regent Replogle moved approval of the recommendation. The following voted yes on the motion: Regents Brett, Mitchell, Bailey, Replogle, Engleman, and White. The Chair declared the motion unanimously carried.

g. Offset Newsprint

Bids were circulated to three vendors for 500,000 lbs. offset newsprint for the Journalism Press for the fiscal year July 1, 1977 through June 30, 1978. The bids were structured to provide for alternate bids on a six months or one year firm fixed price basis, with provision for escalation as an additional alternate.

Payment will be made from Account 177-302, Journalism Press.

Only one bid was received as follows:

Bowater Sales Company		
Price per ton	\$300.00	\$75,000.00

Bowater has been the only past supplier for this paper. The price of \$300.00 represents a \$15.00 per ton increase over last year's price of \$285.00. International Paper did indicate by letter that if they were in a position to bid, they would bid \$305.00 per ton. Therefore, the \$300.00 per ton is considered fair and reasonable to the Director of Printing

Bids were circulated to the following companies:

Bowater Sales Company  
Dallas, Texas 75225

International Paper Company  
Dallas, Texas 75201

Boise Cascade Paper  
Dallas, Texas

Prior to bidding we contacted Kimberly-Clark Corporation, Coosa Pines, Alabama and Crown Zellerback Corporation, San Francisco, California and both companies declined the opportunity to bid.

President Sharp recommended that the Board of Regents approve the award of a purchase order to Bowater Sales for the fiscal year July 1, 1977 through June 30, 1978 for offset newsprint.

Regent Engleman moved approval of the recommendation. The following voted yes on the motion: Regents Brett, Mitchell, Bailey, Replogle, Engleman, and White. The Chair declared the motion unanimously carried.

## VII. Project Financing

### a. Proposal, Contract, and Grant Report

A summary of proposals for contracts and grants for the Norman Campus for April, 1977, as well as a list of all contracts executed during the same period of time on proposals previously reported, was included in the agenda for this meeting.

President Sharp recommended that the President of the University or the President's designees be authorized to execute contracts on the pending proposals as negotiations are completed. The contract budgets may differ from the proposed amounts depending upon these negotiations.

Regent Replogle moved approval of the recommendation. The following voted yes on the motion: Regents Brett, Mitchell, Bailey, Replogle, Engleman, and White. The Chair declared the motion unanimously carried.

## XI. Organizational Changes

a. Center for Environmental Design and Research

President Sharp presented the following proposed policy governing the Center for Environmental Design and Research:

PREAMBLE

This policy is adopted and this Center created with the goal of enriching the academic life in the College by making it possible for the faculty to cooperate on projects within the College to the same extent that they are permitted to work individually outside the College under the University's outside employment policy, enabling them in addition to contribute financially to the College without having to sacrifice entirely remuneration for their professional efforts.

POLICY OBJECTIVES

1. To enhance the professional education programs in the College of Environmental Design at the University of Oklahoma by providing a real world clinical setting for faculty members and students in which they will be involved in environmental design projects oriented toward research and problem solving.
2. To enable the faculty through the exercise of their professional skills to generate additional income for the College without sacrificing entirely remuneration for their professional efforts.
3. To enhance the skills and knowledge of the faculty and students, and therefore, of the Environmental Design professions, in the use and development of multidisciplinary systems affecting the environment, and in policy formulation and problem-solving in general, as well as in design and research methodology.
4. To add to the store of University knowledge in the allied fields of Environmental Design as well as solving the various problems addressed.
5. To provide administrative and financial support for programs, faculty and students of the College engaged in activities of the Center.
6. Through contractual arrangements, to engage in design and research programs for or in collaboration with educational institutions, governmental or public agencies, or for other persons, firms, corporations, or associations whose purposes and/or projects are compatible with those of the Center.
7. To enter into contracts for the delivery of professional services including services to other State Agencies under Title 74 of the Oklahoma Statutes, 1971 Section 1008.
8. To disseminate information about the findings, works, or concerns of the Center through publications.

9. To conduct discussions, seminars or workshops for the purpose of exchanging information and further the state of art of the profession.
10. To provide consultation to professionals of environmental design fields and to work with them in project teams.
11. Execution of all these objectives is subject to all other relevant regular policies and procedures within the University.

#### GOVERNANCE

The Dean, as in all matters internal to the College, shall be responsible for the operation and activities of the Center. The Dean will designate or employ a Director of the Center who shall report to the Dean.

All budget faculty of the College shall be members of the Center, eligible to participate in its activities. Those who are active members shall constitute an Executive Committee whose function is to advise the Dean in matters of Center policy and management. A member is "active" if he/she is currently or have been within the last eighteen months a member of a working project team.

Associate member status shall be granted to other individuals, including graduate students involved in projects of the Center for the duration of their involvement. Associate members may participate in the meetings of the Executive Committee but only regular active members may vote.

In addition, the Dean shall have the benefit of an advisory board composed of three members of the full-time faculty, three members from the community at large and one graduate student, of whom not fewer than four shall be licensed or otherwise qualified professionals of the environmental design professions. This advisory board shall provide continuous review of the policy direction and philosophy of the Center and make recommendations and suggestions to the Dean and to the Executive Committee.

Board members shall serve on a staggered two year term. The Dean of the College shall appoint the members of the first Board; subsequently, election shall be held by voting of members of the Center in their annual meeting. The Board shall elect its Chairperson annually. This Board shall meet no less than once a year.

#### OPERATIONS

The Director of the Center shall be responsible for the business affairs of the Center, including the administration of Center contracts, the collection of Center fees, the handling of Center accounts and the disbursement of Center funds. The Director will also be responsible for originating recommendations on Center personnel to the Dean and for the preparation of an annual Center budget to be submitted to the Dean.



The professional and income producing activities of the Center shall be accomplished through teams working on specific identified projects. No project shall be undertaken until a project team has been identified and the project has been approved by the Dean. The Dean's approval shall not be given unless the Dean is satisfied that the project is compatible with the goals of the College and that the work demanded of team members on the project will not interfere with their regularly assigned activities. In addition, before the Dean approves the project the members of the team must have agreed upon the division of net professional income among themselves.

Each project team shall elect a Project Director who will have the responsibility of coordinating the team members. The Project Director shall work closely with the Center Director in all matters related to the administration of a project.

#### FINANCES

All fees paid to a project team must be deposited in the University's Special Agency Account. Funds shall be disbursed from the University's Special Agency Account for the following purposes and in the order which follows:

1. Payment of all direct expenses related to the project, including reimbursement of direct expenses incurred by team members.
2. Payment of overhead associated with the operation of the Center.
3. Payment of ten percent (10%) of the amount remaining after payment of one and two of the Center Fund.
4. Payment of ten percent (10%) of the amount remaining after one, two and three, shall be made to the Dean's Fund.
5. The balance (the net professional income) to the project team members as professional fees. This shall be divided among the team in the manner agreed upon by the team prior to undertaking the project.

Since there is no past Center experience at the time of the adoption of this policy upon which to calculate an overhead rate the amount to be deducted as overhead shall be set initially at thirty percent (30%). This figure may be modified by the Dean upon recommendation of the Executive Committee and with the concurrence of the Norman Provost. The rate should be sufficient to pay the costs of operating the Center's business office within the College, including the salaries or parts of salaries of personnel hired or allocated part-time to handle Center affairs.

The payment of errors and omissions insurance may be handled on a center-wide basis (as overhead) or project by project as a direct cost.

The Center Director shall prepare an annual budget for the Center for submission to the Dean. This budget should cover all items of expense associated with the operation of the Center and may include recommendations for expenditures from the Center Fund. After the budget has been submitted to the Dean, the Dean will submit it to the Executive Committee for its comments and recommendations. At the same time the Executive Committee shall be advised of the balance on hand in the Center Fund so that it may make recommendations regarding the use of that Fund. The Center Fund shall be maintained in the University's Special Agency Account and may be carried forward from one year to the next. Proper use of this Fund would include (by way of illustration only):

1. The creation of scholarships for capable but needy students.
2. The creation of or contribution to endowed College funds.
3. The funding of research and/or the preparation of grant proposals.
4. Augmenting the operating budget of the College.
5. The purchase of equipment needed by the College or Center.

All equipment purchased, whether for a project (as a direct project expense) or for the Center (as an overhead item) or for the Center or College out of the Center Fund, shall be inventoried to and remain with the College.

#### AMENDMENTS

This policy may be amended from time to time in any particular by the Regents of the University of Oklahoma. Proposed amendments will be submitted to the Dean and Executive Committee for advice and comment. In addition, amendments to the policy may originate in the College. Amendments originating with the College should be approved by two-thirds of the members of the Executive Committee present at two consecutive meetings held not less than thirty (30) days apart. Amendments originating in the College will be forwarded by the Dean to the Provost before being presented to the President for recommendation to the Regents for their consideration.

President Sharp recommended approval of this governance policy to be effective immediately.

Regent Replogle moved approval of the recommendation. The following voted yes on the motion: Regents Brett, Mitchell, Bailey, Replogle, Engleman, and White. The Chair declared the motion unanimously carried.

F. The University Community (Norman Campus)

#### IV. Student Conduct

##### a. Code of Conduct - College of Law

President Sharp presented the following Code of Conduct which was adopted by the College of Law faculty on Friday, April 15, 1977, for the students in the College of Law following a student vote in favor of this Code:

I. Purpose: The purpose of this Code is to establish rules by which the students enrolled in the University of Oklahoma College of Law shall govern their conduct as law students.

II. Scope of Application: The Code of Conduct applies to all students enrolled in the University of Oklahoma College of Law. All students enrolled in the College of Law have a responsibility to support the administration of this Code.

III. Prohibited Conduct: Only the following conduct by a student enrolled in the College of Law is violative of this Code:

##### A. Category One:

1. Violating the written instructions pertaining to an examination, not covered by Category Two;
2. Smoking in an examination room not designated as a "smoking room" during an examination;
3. Talking (not amounting to cheating) in an examination room during an examination except to, or at the direction of, a faculty member; and
4. Creating an unreasonable distraction during an examination whether within or without the examination room;

##### B. Category Two:

1. Cheating on a paper (including plagiarism) or on an examination whether before, during, or after the paper or examination is completed by:
  - a. Knowingly using any unauthorized aid or assistance,
  - b. Knowingly receiving from another law student or from any other source unauthorized aid or assistance, or
  - c. Knowingly giving unauthorized aid or assistance to another law student.

(CAVEAT: Under rules applicable to all students enrolled in the University of Oklahoma a student must be failed on any examination or paper on which (s)he cheats);

2. Duplicating examination questions or examination answers contrary to written instructions on the examination;
3. Knowingly removing an examination or examination answers from the College of Law contrary to written instructions on the examination;
4. Violating written instructions concerning time limitations with respect to an examination, paper, or project;
5. Plagiarizing any material for use in a paper, project, or other material(s) prepared for or submitted as a partial or entire course requirement, or for a prize competition;
6. Falsifying, either for himself/herself or on behalf of another student, any roster maintained for implementing an attendance policy;
7. Appropriating in excess of authorization to his/her own use or for use of another, or hiding, or mutilating notes, research, prepared assignments, or book(s) whether belonging to or being used by another law student, the law library, or a faculty member;
8. Knowingly failing to return an overdue book or other material of the law library upon request of the law library, if the return was possible;
9. Possessing or transferring without authority or duplicating Law Center keys;
10. Making intentional misrepresentation(s) in matters relating to this Code to the Magistrate, to the Prosecutor, to a faculty member, or during any hearing or proceeding under this Code.

C. For a violation of conduct listed in Category One, the Hearing Panel may not make a recommendation in excess of a written reprimand (See paragraphs IV (C) (3) (h) 1. through 3.). For a violation of conduct listed in Category Two, the Hearing Panel may make any recommendations permitted by this Code (See paragraphs IV (C) (3) (h) 1. through 9.).

D. Additional conduct may be made violative of this Code, or an existing violation may be deleted from the enumerated violations of this Code by amendment of this Code according to the provisions of the Oklahoma Administrative Procedures Act (75 O.S. §§301 et seq.); any such addition or deletion shall have prospective effect only.

#### IV. Administration of the Code of Conduct:

A. The Magistrate and The Prosecutor: To be eligible for either the office of Magistrate or the office of Prosecutor, a student must have completed all of the required first year courses, must not be on academic probation, and must be currently enrolled as a full-time student in the College of Law;

1. A Magistrate shall be appointed each December by the Board of Governors of the Student Bar Association (or successor organization) [hereinafter referred to as Board of Governors] for a one-year term. The term of the Magistrate shall run from January 1 through December 31. The Magistrate shall at time of appointment be a second year student. Two Alternate Magistrates shall be appointed, at the same time and in the same manner as the Magistrate. The Board of Governors shall designate the order in which the Alternates shall serve as Magistrate in any case in which a Magistrate disqualifies himself/herself. If neither the regular Magistrate nor the Alternates can serve in a particular case, the Board of Governors shall appoint a Magistrate pro tempore for that case.

2. A Prosecutor shall be appointed each December by the Board of Governors for a one-year term. The term of the Prosecutor shall run from January 1 through December 31. The Prosecutor shall at time of appointment be a second-year student. The Prosecutor shall investigate all alleged violations of this Code and shall prosecute all alleged violations for which a prima facie case exists. Two Alternate Prosecutors shall be appointed, at the same time and in the same manner as the Prosecutor. The Board of Governors shall designate the order in which the Alternates shall serve as Prosecutor in any case in which a Prosecutor disqualifies himself/herself. If neither the regular Prosecutor nor the Alternates can serve in a particular case, the Board of Governors shall appoint a Prosecutor pro tempore for that case.

B. The Judge. A member of the College of Law faculty shall be chosen to serve a one-year term (September through August) as the Judge for the Code of Conduct. (S)he shall be selected by the Board of Governors from among three nominees submitted by the Dean of the College of Law. The Judge shall not be present at hearings before the Magistrate but shall be available to consult with the Magistrate; at any such consultation, the student accused of violating this Code (or his/her representative) shall have a right to be present. The Judge shall preside at all proceedings before the Hearing Panel. If the faculty member is unable to participate in a particular case, the Board of Governors shall select an Alternate from three nominees submitted by the Dean of the College of Law for that purpose.

C. Processing an Alleged Violation:

1. Reporting and Notice: Every student enrolled in the College of Law has a responsibility to report any alleged violation of this Code. Any other person may also report an alleged violation of this Code. Any person reporting an alleged violation has a responsibility to maintain confidentiality with respect to the matters reported.

a. Alleged violations of this Code occurring during an examination shall be orally reported as soon as practicable by the accusing party to the faculty member who is to be located by the elevator on the first floor of the College of Law. An alleged violation of this Code occurring during an examination must be reported by the accusing party within ten (10) days from the last day of the examination period in which the examination was given in the same manner as an alleged violation of this Code not occurring during an examination is to be reported.

b. Alleged violations of this Code not occurring during an examination shall be reported in writing, signed by the accusing party. The writing shall either be given to the Prosecutor, be placed in the Prosecutor's mailbox, or be delivered in a sealed envelope to the Dean or Associate Dean of the College of Law for delivery unopened to the Prosecutor. Except for alleged violations of this Code occurring during an examination, the report of an alleged violation of this Code must be made within ten (10) days from the date of the alleged violation.

c. The Prosecutor upon receiving a report of an alleged violation of this Code must make every reasonable effort to inform the accused student and the Dean of the College of Law of the accusation within three (3) days of its receipt. Within seven (7) days, the Prosecutor is to prepare a complaint based on the alleged violation and personally deliver the complaint to the accused student or mail it to the accused student by certified mail (restricted delivery), return receipt requested. In addition to providing the accused student the complaint, the Prosecutor shall advise the accused student in writing that (s)he has the rights of a party in an individual proceeding under the Oklahoma Administrative Procedures Act (75 O.S. §§301 et seq.).

d. Not later than fifteen (15) days from the date the complaint is received by the student accused of violating this Code, the Prosecutor must investigate the alleged violation; make a determination whether a prima facie case exists that the accused student has violated this Code; and if a prima facie case does exist, deliver a copy of the complaint to the Magistrate.

## 2. Hearing by the Magistrate:

a. The Magistrate shall set a date (which shall be no earlier than ten (10) days and no later than twenty (20) days after (s)he has received the complaint of an alleged violation of this Code from the Prosecutor) to inquire into the alleged violation and shall notify the accused student in writing either personally or by certified mail (restricted delivery), return receipt requested, of the date, time, and place of the hearing; of the authority and jurisdiction under which the hearing is to be held; of the particular section(s) of the Code of Conduct involved; and concisely and plainly of the matter(s) asserted.

b. An accused student may waive in writing to the Magistrate his/her right to a hearing before the Magistrate and may have the matter proceed directly to a proceeding before the Hearing Panel.

c. The Magistrate shall convene the hearing to determine whether probable cause exists to believe that the accused student has violated the Code of Conduct. At the hearing before the Magistrate, the Prosecutor shall present the evidence against the accused student, and the accused student may present matters in defense.

d. If the Magistrate determines that no probable cause exists to believe that the accused student has violated the Code of Conduct, the Magistrate shall cause all records of the proceeding to be destroyed and shall notify the

Prosecutor to destroy his/her records of the case. The Magistrate shall notify the accused student in writing of the determination.

e. If the Magistrate finds probable cause exists to believe that the accused student has violated the Code of Conduct, the Magistrate shall issue a written order to that effect. The order shall contain findings of fact and conclusions of law, and a copy of the order shall be furnished by the Magistrate to the accused student either personally or by certified mail (restricted delivery), return receipt requested, and to the Prosecutor. The Magistrate shall notify the Judge and the Prosecutor in writing that the student has waived his/her right to a hearing or that probable cause exists to believe that particular section(s) of this Code have been violated (which shall be specified) by the accused student (who shall be named) and that a proceeding will be held before the Hearing Panel.

3. Proceeding before the Hearing Panel:

a. Upon being furnished a copy of the Magistrate's order that probable cause exists to believe that the accused student has violated the Code of Conduct or that the accused student has waived to the Magistrate in writing his/her right to a hearing, the Judge shall notify the accused student in writing, either personally or by certified mail (restricted delivery), return receipt requested, of the date, time, and place of the proceeding before the Hearing Panel; of the authority and jurisdiction under which the proceeding is to be held; the particular section(s) of the Code of Conduct involved; and concisely and plainly of the matters asserted. The proceeding before the Hearing Panel is to be held within a reasonable time (but not later than fifteen (15) days) after notice to the accused student.

b. The Judge shall direct the Board of Governors to select a Hearing Panel to hear the matter. The Hearing Panel shall be drawn as follows: An initial panel of at least forty (40) students shall be picked by lottery by the Board of Governors from the students enrolled in the College of Law. Where the alleged violation concerns conduct in a particular class or examination, all students in that class or taking that examination shall automatically be eliminated from the initial panel. The Board of Governors shall request the students drawn be present on the date, time, and place of the proceeding before the Hearing Panel.

c. From the initial panel, six students will be called in the order in which their names were selected by the original lottery; others will be called in like fashion, as necessary, from the initial panel. Each accused student shall have five preemptory challenges. The Prosecutor shall have five preemptory challenges. Either the prosecutor or the accused student may challenge for cause; reasonable voir dire shall be permitted. A total of six students shall be selected to form the Hearing Panel; two alternates shall also be selected in case a member of the Hearing Panel is unable to sit for the entire case. If the Hearing Panel and two alternates cannot be selected from the students drawn by lottery for the initial panel, additional students shall, in the same manner, be picked by lottery and called until the Hearing Panel is filled and two alternates selected. All eligible students in the College of Law have a responsibility to serve on the Hearing Panel when selected.

d. At the proceeding before the Hearing Panel, the Prosecutor shall present the evidence against the accused student, and the accused student may present matters in defense. Opening and closing statements shall occur in like order. All proceedings shall be video-taped (unless otherwise directed by the Judge) under the direction of the Dean and upon request made available to the accused student or the Prosecutor.

e. In addition to presiding at the proceeding before the Hearing Panel, the Judge shall rule on challenges to Hearing Panel, objections, admissibility of evidence, motions, etc. (S)he is to use the Oklahoma Administration Procedures Act (75 O.S. §§301 et seq.) as authority.

f. The Hearing Panel shall hear all evidence presented by the Prosecutor and by the accused student and shall reach a decision by determining whether the accused student did beyond a reasonable doubt violate the Code of Conduct. No student may be found to have violated this Code unless four (4) members of the Hearing Panel concur in that determination. If less than four (4) members of the Hearing Panel do not concur in a determination that the accused student has violated this Code, the decision of the Hearing Panel shall be that no violation occurred.

g. If the Hearing Panel determines that no violation of the Code of Conduct has occurred, it shall enter a written order, authenticated by the Judge, so stating and directing the Prosecutor to destroy all records of the proceeding. If the Hearing Panel determines that a violation of the Code of Conduct has occurred, it shall enter a written order, authenticated by the Judge, containing findings of fact and conclusions of law. The accused student shall be furnished a copy of the order.

h. After entering its order that a student has violated the Code and before determining its recommendation for action, the Hearing Panel shall hear and consider any matters in extenuation and mitigation presented by the student, as well as any matters of aggravation presented by the Prosecutor. The Hearing Panel shall recommend to the Dean of the College of Law one or more of the following with respect to the student found to have violated the Code of Conduct:

1. no action be taken;
2. an oral reprimand be given;
3. a written reprimand be given;
4. reduction (to include reduction to an F) of the grade for the course involved, if any, in the violation (CAVEAT: Under rules applicable to all students enrolled in the University of Oklahoma a student must be failed on any examination or paper on which (s)he cheats);
5. suspension from the College of Law for the remainder of the current semester or summer session;



6. suspension from the College of Law for a summer session;
7. suspension from the College of Law for a semester;
8. suspension from the College of Law for one year, or more; or
9. expulsion.

Note: Any suspension under (5) through (8) above shall toll for the duration of the suspension the six (6) year degree requirement of the College of Law.

i. Any recommended action of the Hearing Panel against the student shall be made only upon concurrence of four (4) members of the Hearing Panel. If less than four (4) members of the Hearing Panel cannot concur in a recommended action, the recommendation of the Hearing Panel shall be that no action be taken against the student. The recommended action shall be included in the order of the Hearing Panel.

j. The name (and other identifying information) of the student found to have violated this Code may be removed by the Magistrate from the records of the Magistrate, the Prosecutor, and the Judge upon graduation of the student, upon transfer of the student out of the College of Law, or after five (5) years, and shall be removed by the Magistrate from the records of the Magistrate, the Prosecutor, and the Judge after graduation of the student, after transfer of the student out of the College of Law, or after five (5) years if requested by the student at that time. The Hearing Panel may recommend in its order that a written reprimand remain in the student's College of Law records for a stated period of time and then be removed and destroyed. The student found to have violated this Code is responsible for assuring that, if recommended by the Hearing Panel, the written reprimand (and any accompanying documents) are removed at the appropriate time.

4. Report to the Dean; Dean's Decision; Appeal: The Judge shall inform the Dean of the College of Law within three (3) days of the decision of the Hearing Panel by delivering to him/her a copy of the order of the Hearing Panel. If the Hearing Panel has found no violation of the Code of Conduct, the Dean shall cause all College of Law records of the proceeding against the accused student to be destroyed. If the Hearing Panel has found a violation of the Code of Conduct, the student who was found to have violated the Code of Conduct may appear before the Dean to request a reduction in the recommendation of the Hearing Panel. The Dean may impose the recommendation of the Hearing Panel or reduce the recommendation, but (s)he may not increase the recommendation. The decision of the Dean may be appealed to the President of the University whose decision shall be final. Pending appeal to the President, the decision of the Dean may be stayed by the Faculty of the College of Law.

#### V. Miscellaneous

A. Any interested person may request a declaratory judgment or ruling according to 75 O.S. §§306, 307.

B. The "agency" for the purposes of adopting, amending, or repealing this Code of Conduct is the Faculty of the College of Law.

C. The Faculty of the College of Law delegates its factfinding role under this Code of Conduct to the Hearing Panel.

D. The Dean of the College of Law (or his/her designate) who is to be located in the administrative offices on the second floor shall distribute "bluebooks," typing paper, and writing instruments on a reimbursable basis to any law student who is in need of such materials during an examination.

E. The Board of Governors shall instruct first-year students, during the first-week orientation, on the Code of Conduct. A student transferring to the University of Oklahoma College of Law from another law school shall be provided a copy of this Code when (s)he is accepted for admission. A copy of this Code of Conduct shall be placed on reserve in the College of Law Library. Before a student obtains his/her examination test number, (s)he shall indicate that (s)he is aware of the provisions of this Code.

F. For the purposes of this Code, a "day" shall be limited to any day, Monday through Friday, on which the College of Law holds regularly scheduled class(es), but shall not include any days during the examination period.

G. From time to time as the Board of Governors determines is necessary, the Code of Conduct shall be submitted to a vote of the students enrolled in the College of Law as to the Code's acceptability; the Board of Governors shall inform the Faculty of the College of Law as to the result of such votes.

H. The provisions of this Code shall not restrict the powers and duties of the faculty of the College of Law pursuant to applicable rules and regulations of the University.

#### VI. Transition

Within ten (10) days of the effective date of this Code of Conduct, the Board of Governors shall appoint a Magistrate and a Prosecutor to serve until December 31, 1977, and select a Judge for the Code of Conduct from the nominees submitted by the Dean of the College of Law to serve until August 31, 1977, as well as immediately establish a mailbox for the Prosecutor to be used for the reporting of alleged violations of this Code.

Adopted pursuant to the Oklahoma Administrative Procedures Act (75 O.S. §§301 et seq.) by the Faculty of the College of Law at its meeting of April 15, 1977, held as announced in the Oklahoma Gazette of March 15, 1977; filed with appropriate state offices on April 18, 1977, to become effective twenty days thereafter.

Regent White reported the Student Affairs Committee of the Board reviewed the Code at the meeting yesterday and recommends approval of President Sharp's recommendation that the Code of Conduct as presented be ratified. He moved approval of the recommendation. The following voted yes on the motion: Regents Brett, Mitchell, Bailey, Replogle, Engleman, and White. The Chair declared the motion unanimously carried.

## G. Operations and Physical Plant (Norman Campus)

### I. New Construction

#### a. Athletic Dormitory

The tabulation of the bids received on construction of the Athletic Dormitory as shown on the attached page was distributed to each Regent. Regent Mitchell said these bids were reviewed by the Facilities Planning Committee at the meeting yesterday. The Committee recommends approval of the following recommendation of President Sharp:

1. That the project budget be increased from \$1,000,000 to \$1,300,000, and
2. That a contract be awarded to J. J. Cook Construction, Inc. on the basis of:
  - a. The low base bid,
  - b. Alternates 1B, 2, 4, 5, and 6 for a total contract amount of \$1,113,388, and
  - c. That a change order to the construction contract incorporating a cost reduction of \$10,000 be authorized for a net amount of \$1,103,388.

Regent Mitchell moved approval of the recommendation. The following voted yes on the motion: Regents Brett, Mitchell, Bailey, Replogle, Engleman, and White. The Chair declared the motion unanimously carried.

#### b. Report on Major Capital Improvements Projects

As shown on the following page a report was presented to the Regents on major capital improvements projects now under construction and in various stages of planning on the Norman Campus. No action was required.

### II. Repairs, Remodeling, Renovation

#### a. Safety Modifications - DeBarr Hall

At the request of the Chemistry Department, President Sharp said the University Fire Marshal conducted a survey of Chemistry facilities in DeBarr Hall and DeBarr Annex with regard to improved safety to life.

Specific recommendations in the report he submitted are (1) that fire and safety equipment be acquired and installed in the facilities of the Chemistry Department to satisfy the short-term, urgent needs for improved life-safety of the occupants, (2) that smoke detectors be installed and that a manual fire

alarm system connected to Police headquarters for remote monitoring be established, (3) that modifications be made to exit fixtures and doorways. These short-term recommendations do not include the structural modifications to DeBarr Hall which are necessary to achieve complete compliance with fire and other applicable codes which are included in the major capital improvement plans for renovation of DeBarr Hall. The report also reiterates the need for a completely separate facility to function as a campus wide hazardous materials storeroom/warehouse, which is also included in the University's major capital improvements plan.

The OU Police Department and the Physical Plant Department have estimated the cost of acquisition and installation of the fire and safety equipment and modifications recommended to the Chemistry Department facilities in DeBarr Hall and DeBarr Annex at \$65,000. Funds are immediately available from Section 13/New College Funds to pay for this project. This project was not included in the Section 13/New College project priority list approved by the University Regents in January 1977. However, due to the urgency of this matter, it is recommended that the modifications to the Chemistry facilities be taken care of immediately.

President Sharp recommended that the expenditure of \$65,000 in Section 13/New College funds be authorized for purchase and installation of fire and safety equipment in Chemistry Department facilities in DeBarr Hall and DeBarr Annex to satisfy short-term, urgent needs for safety of the occupants.

Regent Mitchell said this project was reviewed by the Facilities Planning Committee and the Committee recommends approval of the recommendation. He moved approval. The following voted yes on the motion: Regents Brett, Mitchell, Bailey, Replogle, Engleman, and White. The Chair declared the motion unanimously carried.

#### IV. Contracts and Agreements

##### a. Summer Institute of Linguistics

The University has been contracting with the Summer Institute of Linguistics for a number of years for the use of space during the summer to conduct their language instruction program. The terms of this agreement are basically the same as they have been in the past except the rates for use of space have been increased from \$4,500 to \$5,000 for each non-air-conditioned building in Cate Center and an increase from \$7,000 to \$8,000 for each air conditioned building in Cate Center. This charge includes a central dining and kitchen facility, all utilities, maintenance, property insurance and janitorial service for public areas.

The students of the Institute pay the regular fees charged to students of the University. The University compensates the Summer Institute of Linguistics for this instruction. The rate for 1976 was \$36,555 for the first 1000 hours of

ARCHITECTURAL AND ENGINEERING SERVICES  
UNIVERSITY OF OKLAHOMA

May 5, 1977

ATHLETIC DORMITORY  
Norman, Oklahoma

Architect: Coleman-Ervin & Associates  
124 E. 4th, Tulsa, Oklahoma

<u>CONTRACTOR</u>	<u>BASE BID</u>	1A	1B	ALTERNATES							
				2	3	4	5	6	7	8	
Barbour and Short, Incorporated	1,066,743	No bid	69,853	3,611	2,599	19,072	6,765	2,174	12,324	785	
Clyde Burton & Son Const. Co.	1,049,200	No bid	58,800	3,569	2,734	21,198	3,508	530	20,238	225	
J.J. Cook Construction, Inc.	1,006,952	No bid	74,821	2,449	4,353	23,233	4,863	1,070	12,735	808	
The Constructors Company	1,120,900	37,000	44,900	3,375	3,150	27,240	6,060	1,100	11,220	1,000	
E.V. Cox Construction Co. Inc.	1,071,000	36,600	43,100	2,900	2,700	21,200	5,600	950	10,800	600	
Delco Construction, Inc.	1,037,000	56,000	58,700	3,200	2,800	28,500	6,800	1,700	12,700	800	
R. Johnson, Inc.	1,136,400	37,700	45,550	3,610	3,300	26,800	5,990	1,140	12,000	990	
Walter Nashert & Sons, Inc.	1,055,000	73,000	60,000	3,500	1,500	23,500	5,000	2,000	12,800	600	
United Builders, Inc.	1,097,000	No bid	56,800	3,200	4,300	30,000	6,300	2,400	13,000	800	

ALTERNATES

- 1A - built-in equipment, plastic clad
- 1B - built-ins, wood
- 2 - brick veneer
- 3 - kitchen equipment
- 4 - interior plaster
- 5 - brick paving
- 6 - grass
- 7 - window frames
- 8 - window frames

CERTIFIED TABULATION OF BIDS

*Arthur N. Tuttle, Jr.*  
Arthur N. Tuttle, Jr.

ARCHITECTURAL AND ENGINEERING SERVICES  
THE UNIVERSITY OF OKLAHOMA

MAJOR CAPITAL IMPROVEMENTS PROGRAM

PROGRESS REPORT, MAY, 1977

PROJECTS UNDER CONSTRUCTION

Project	Engineers and Architect	Contractor	Contract Award Date	Original Adjusted Completion Date	Original Current Contract Amount	Status (% complete)	Sources of Funds
NORMAN CAMPUS							
Lloyd Noble Center	Binnicker Assoc.	Rayco Construction Company	01/11/73	01/10/75 <u>05/15/75</u>	4,929,000 <u>5,093,961</u>	96%	Student Facilities System Bond of 1971, Private Funds and Student Facilities Fee Reserve
College of Environmental Design	Howard-Samis- Porch, Inc	Novak & Lackey Construction Co., Inc.	01/13/77	07/19/77	644,220 <u>712,313</u>	58%	Bond Funds
Westheimer Field Lighting Project	Carnahan, Thompson, Delano	Williams Electric Co.,	03/10/77	03/25/78	109,987 <u>115,536</u>	0%	FAA Grant, Westheimer Field Auxiliary Services Account

ARCHITECTURAL AND ENGINEERING SERVICES  
THE UNIVERSITY OF OKLAHOMA

MAJOR CAPITAL IMPROVEMENTS PROGRAM

PROGRESS REPORT, MAY, 1977

PROJECTS IN VARIOUS STAGES OF PLANNING

Project	CMP Priority No.	Architect	Contract or Letter	Estimated Cost	Status
NORMAN CAMPUS					
Richards Hall Renovation	1	McCune & McCune	C06/10/76	\$1,137,000	Design development phase plans are being completed
Richards Hall Fixed Equipment	2	McCune & McCune	"	185,120	Will be installed with project funds
Old Science Hall Renovation	4	Shaw Associates, Inc.	C01/22/76	278,000	Schematic plans have been approved
Old Science Hall Fixed Equipment	5	Bass & Associates	"	68,202	" "
Felgar Hall Renovation	12	Turnbull & Mills	C01/22/76	805,000	Working drawings and specifications have been approved
Felgar Hall Fixed Equipment (Includes TBT Equipment)	13	"	"	18,152	Will be installed with project funds
Nielsen Hall Renovation	18	Howard-Samis- Porch, Inc.	C01/22/76	496,000	Working drawings and specifications have been approved
Nielsen Hall Fixed Equipment	19	"	"	7,157	" "
DeBarr Hall Renovation	21	Turnbull & Mills	C01/22/76	465,295	Working drawings and specifications have been approved
DeBarr Hall Fixed Equipment	22	"	"	10,885	" "
Monnet Hall Conversion	51	--	--	101,500	A reuse study is in process
Law Center - Phase II	53	Stone & Associates	C01/20/72	1,812,000	Design program and schematic plans for this phase of the work are included with the Law Center, Phase I Project
Physical Education Facility	23-A	Reid and Heap	L10/16/66	1,903,000	A feasibility study is in process. Implementation of this project is contingent on development of sources of funding
Student Recreation Center	23-B	"	"	2,612,000	
South Stadium Expansion	--	A&E Services	--	625,000	Inactive
Varsity & Visiting Team Facility	--	"	--	825,000	"
Athletic Dormitory	--	Coleman-Ervin & Associates	--	1,000,000	Final plans have been approved. Bids are to be received in May
University Parking Structure	--	Benham/Blair & Affiliates, Inc.	--	1,020,000	The future of this project is undergoing review

instruction and \$1,777.00 for each additional 50 hours. The 1977 rates will be \$43,866 for the first 1000 hours and \$2,200 for each additional 50 hours of instruction. This is necessary because of increasing costs of instruction incurred by the Summer Institute of Linguistics.

The agreement provides for renewal from year to year on mutual agreement by both parties.

Besides being quite prestigious, the Institute provides a number of fringe benefits to the University including allowing us to fill normally vacant dormitory space during the summer.

President Sharp recommended approval of entering into the agreement with the Summer Institute of Linguistics as explained above.

Regent Replogle moved approval of the recommendation. The following voted yes on the motion: Regents Brett, Mitchell, Bailey, Replogle, Engleman, and White. The Chair declared the motion unanimously carried.

## V. University Property

### a. Ellsworth Collings Hall

The faculty of the College of Education and Dean Richard Wisniewski have proposed that the College of Education Building be named the Ellsworth Collings Hall. This proposal has been considered by the Administrative and Physical Resources Council. The Council voted unanimously to recommend to President Sharp that the Education Building be named the Ellsworth Collings Hall.

Ellsworth Collings joined the Education faculty in 1922 and served continuously until his retirement on July 1, 1958. During these years he was untiring in his efforts to advance the field of education and the preparation of teachers. At the time of retirement he was a nationally recognized contributor and leader in the field of professional education and teacher education. He was innovative in his approaches and constantly sought improvement for educational programs through carefully planned experimentation.

Ellsworth Collings was appointed Dean of the School of Education in July, 1926. Shortly thereafter he started working to have the School of Education changed to the College of Education with the right to set its admission and graduation requirements. These efforts resulted in the School of Education being officially established as the College of Education in 1929. Dr. Collings continued to serve as Dean of the College of Education until July, 1944. At that time he gave up administrative responsibilities and turned his efforts to full-time teaching. This he continued until retirement.

During Dean Collings' tenure as Dean several noteworthy changes were made. Some of which were the following: (a) the extension program was expanded both in courses offered and areas of the state served, (b) University School was



expanded from a 4-year high school to provide for Kindergarten through grade 12, (c) provisions for practicing teaching and observation were reorganized to include both on-campus and off-campus assignment, (d) a Bureau of Educational Research to serve the College and public schools was established, (e) he professionally encouraged and promoted the two established honorary fraternities in education, and (f) he professionally encouraged and promoted a cooperative working relationship between University departments contributing to teacher preparation.

President Sharp recommended approval of naming the Education Building the Ellsworth Collings Hall.

Regent Engleman moved approval of the recommendation. The following voted yes on the motion: Regents Brett, Mitchell, Bailey, Replogle, Engleman, and White. The Chair declared the motion unanimously carried.

#### H. University Development

##### V. Gifts and Bequests

###### a. Notification of Gift

President Sharp said the University of Oklahoma has received a gift of \$61,692.80 Canadian dollars resulting from the sale of shares, given to the University, of H. C. Price of Canada, Ltd. The gift, worth approximately \$58,500.00 U.S. dollars, was made by Mr. and Mrs. Harold C. Price of Bartlesville. The gift is for unrestricted educational purposes and may be spent at the discretion of the President of the University.

Regent Brett said he would like to express publicly the sincere appreciation of the University to the Prices for their generosity and continuing interest in the University of Oklahoma.

There being no further business the meeting was adjourned at 11:45 a.m.

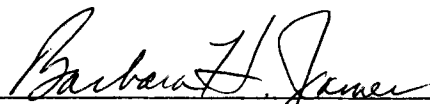
  
Barbara H. James  
Executive Secretary of the  
Board of Regents

Others present at all or part of the meeting:

Mr. Robert B. Lewis, Leo Oppenheim & Co.  
Mr. Rod Durrell, Leo Oppenheim & Co.  
Mr. Scott Brown, Bond Counsel  
Mr. Bob Shepard, Director, Computing Center

May 12, 1977

14469

Professor Junetta Davis, Journalism

Dr. Beverly Ledbetter, University Legal Counsel

Mr. Earl Whitman, University Purchasing Director

Mr. Carter Bradley, Executive Director, HEACO

Mr. Arthur Tuttle, University Architect

Ms. Donna Murphy, Assistant Director of Media Information for News Services

Mr. Mike Sulzycki, Radio Writer-Producer, Media Information

Mr. Larry Lium, Director of Information Services

Mr. Joe Flowers, Director of Information Services, Health Sciences Center

Mr. Jim Kirby, Media Information Office, Health Sciences Center

Mr. Jim Killacky, Daily Oklahoman

Mr. Bill Reavis, KTVY

Mr. Tom Daniels, KWTW

Ms. Joy Donovan, Tulsa World

Mr. Irv Watson, Oklahoma City Times

Mr. Jim Bross, The Norman Transcript

PROPOSED SPECIAL OBLIGATION REFUNDING BOND ISSUE  
CENTRAL STEAM AND CHILLED WATER FACILITIES

OFFICIAL STATEMENT

REGENTS

OF THE

UNIVERSITY OF OKLAHOMA

UTILITY SYSTEM SPECIAL OBLIGATION REFUNDING BONDS, SERIES 1977

Submitted for Consideration of the  
Oklahoma State Regents For Higher Education

May 23, 1977

The Special Obligation Bonds are offered only by means of this Official Statement. This Official Statement does not constitute an offering of any security other than the Special Obligation Bonds specifically offered hereby. It does not constitute an offer to sell or a solicitation of an offer to buy the Special Obligation Bonds in any State or jurisdiction to any person to whom it is unlawful to make such offer, solicitation or sale, and no dealer, broker, salesman or other person has been authorized to make such unlawful offer, solicitation or sale. No dealer, broker, salesman or other person has been authorized to give any information or to make any representations other than those contained in the Official Statement in connection with the offering of the Special Obligation Bonds and, if given or made, such other information or representations must not be relied upon.

TABLE OF CONTENTS

	Page
The University of Oklahoma - Board of Regents and University Officials . . .	2
Description . . . . .	3
Maturity Schedule . . . . .	3
The University of Oklahoma and the Board of Regents . . . . .	4
Plan of Financing . . . . .	4
The Special Obligation Bonds . . . . .	6
Description of the Bonds . . . . .	6
Redemption Provisions . . . . .	6
Security for the Bonds . . . . .	7
Additional Bonds . . . . .	7
Risks of Bondholders . . . . .	7
Use of Bond Proceeds . . . . .	8
Summary of Certain Provisions of the Special Obligation Bond Resolution . .	8
Summary of Certain Provisions of the Refunding Escrow Agreement . . . . .	12
Certification of Mathematical Computations . . . . .	13
Presently Outstanding Bonds . . . . .	13
Underwriting . . . . .	13
Legal Opinions and Tax Exemption . . . . .	14
No Litigation . . . . .	14
Ratings . . . . .	14
Miscellaneous . . . . .	15
 Exhibits	
A - Funding of Debt Service Requirements of Special Obligation Bonds	
B - Maturing Principal of and Interest Earned on Government Securities	
C - Statement of Outstanding Bonds	

The Special Obligation Bonds are offered when, as and if issued and received by the Underwriters, subject to prior sale, to withdrawal or modifications of the offer without any notice, and to the approval of legality of the Special Obligation Bonds by Fagi Brown, Bush, Selvidge & Tinney, Oklahoma City, Oklahoma, Bond Counsel. It is expected that the Special Obligation Bonds in definitive form will be available for delivery to the Underwriters in \_\_\_\_\_, on or about \_\_\_\_\_.

THE UNIVERSITY OF OKLAHOMA

BOARD OF REGENTS

Mr. Thomas R. Brett, Tulsa  
President

Mr. Richard A. Bell, Norman

Bob G. Mitchell, M.D., Sallisaw  
Vice President

Mr. Dee A. Replogle, Jr., Oklahoma City

Mr. Charles E. Engleman, Clinton

Mr. K. D. Bailey, Okmulgee

Ronald H. White, M.D., Oklahoma City

UNIVERSITY OFFICIALS INCLUDE

Dr. Paul F. Sharp, President

William G. Thurman, M.D., Provost, Health Sciences Center

Dr. Gene M. Nordby, Vice President for Administration & Finance

UNIVERSITY COUNSEL

Mr. Thomas H. Tucker, Chief Counsel

ENGINEERS

Carnahan-Thompson-Delano, Inc.,  
Oklahoma City, Oklahoma

BOND COUNSEL

Fagin, Brown, Bush, Selvidge & Tinney,  
Oklahoma City, Oklahoma

FINANCIAL CONSULTANT

Leo Oppenheim & Co., Inc.  
Oklahoma City, Oklahoma

The information contained in this Official Statement has been compiled from sources believed to be reliable. The Official Statement contains estimates and matters of opinion which are not intended as representative of fact. This Official Statement is not to be construed as a contract with the purchasers of the Bonds.

THE DATE OF THE OFFICIAL STATEMENT IS \_\_\_\_\_, 1977.

Interest exempt, in the opinion of Bond Counsel, from all present Federal and State of Oklahoma Income Taxes under existing statutes, regulations and court decisions.

OFFICIAL STATEMENT

NEW ISSUE

Moody's: \_\_\_\_\_  
Standard & Poor's: \_\_\_\_\_

\$3,705,000 \*

REGENTS OF THE UNIVERSITY OF OKLAHOMA

UTILITY SYSTEM SPECIAL OBLIGATION REFUNDING BONDS, SERIES 1977

Dated: July 1, 1977

Due: January 1 and July 1, as shown below

Principal and semi-annual interest (January 1 and July 1, first coupon payable January 1, 1978) are payable at The First National Bank and Trust Company of Oklahoma City, Oklahoma City, Oklahoma, (the "Bank"); or at the option of the holder thereof at the Fiscal Agency of the State of Oklahoma in the City of New York, New York; or in the event of the discontinuance of that Agency, then at The Chase Manhattan Bank (National Association), New York, New York. The Regents of the University of Oklahoma Utility System Special Obligation Refunding Bonds, Series 1977, (the "Special Obligation Bonds"), are issued in the form of coupon bonds in the denomination of \$5,000 each registrable as to principal only, or in fully registered form in \$5,000 denominations, or with respect to principal maturing on the same date, in multiples thereof. The Special Obligation Bonds are not subject to redemption prior to maturity. The Special Obligation Bonds are not an indebtedness of the State of Oklahoma, the University of Oklahoma (the "University"), or the Board of Regents of the University of Oklahoma (the "Board of Regents"), but are special obligations payable solely from certain escrow funds of certain direct obligations of the United States of America held in escrow by The First National Bank and Trust Company of Oklahoma City, Oklahoma. The Special Obligations Bonds and the Board of Regent's \$6,850,000 Utility System Revenue Refunding Bonds, Series 1977 (the "Revenue Bonds"), which are being offered simultaneously with the Special Obligation Bonds under a separate Official Statement, are being issued to provide funds to advance refund the outstanding portion of the \$6,500,000 Board of Regents Utility System Revenue Bonds, Series 1975. The refunding Revenue Bonds are not equally or ratably secured with the Special Obligation Bonds.

MATURITY SCHEDULE

The Bonds are dated July 1, 1977, and are due on January 1 and July 1 of each year and in the principal amounts as shown on the following page:

\* Approximate amount, subject to change.

<u>Maturity Date</u>	<u>Principal Amount</u>	<u>Interest Rate</u>	<u>Price or Yield</u>	<u>Maturity Date</u>	<u>Principal Amount</u>	<u>Interest Rate</u>	<u>Price or Yield</u>
1-1-78	\$235,000			7-1-82	\$220,000		
7-1-78	235,000			1-1-83	215,000		
1-1-79	230,000			7-1-83	215,000		
7-1-79	230,000			1-1-84	210,000		
1-1-80	230,000			7-1-84	200,000		
7-1-80	225,000			1-1-85	200,000		
1-1-81	225,000			7-1-85	195,000		
7-1-81	225,000			1-1-86	190,000		
1-1-82	225,000						

(Plus Accrued Interest)

### THE UNIVERSITY OF OKLAHOMA AND THE BOARD OF REGENTS

The University is a member of The Oklahoma State System of Higher Education that includes all collegiate institutions in Oklahoma supported wholly, or in part, by State appropriations. The government of the University is vested in the Board of Regents, a constitutional board of seven members appointed by the Governor of the State of Oklahoma for staggered seven year terms, subject to confirmation by the State Senate. Members of the Board of Regents are listed on Page 2 of this Official Statement. The Board of Regents issues bonds under the provisions of Title 70, Oklahoma Statutes, 1971, Sections 4001 to 4014, inclusive, as amended.

### PLAN OF FINANCING

The purpose of this Official Statement, including the Exhibits hereto, is to give certain essential facts relating to the Board of Regents and the University in connection with the offering of \$3,705,000 Regents of the University of Oklahoma, Utility System Special Obligation Refunding Bonds, Series 1977, dated July 1, 1977. The Special Obligation Bonds are issued pursuant to a Special Obligation Bond Resolution dated as of July 1, 1977 under which the Bank is Trustee. The Bank is also serving as Trustee under the 1977 Supplemental Bond Resolution securing the Revenue Bonds and as the Escrow Agent under the Refunding Escrow Agreement described herein.

The University issued \$6,500,000 principal amount Utility System Revenue Bonds, Series 1975 dated January 1, 1975, (the "Series 1975 Bonds"), on February 18, 1975, pursuant to a Supplemental Bond Resolution, (the "1975 Supplemental Bond Resolution") dated as of January 1, 1975, under which The First National Bank and Trust Company of Oklahoma City, Oklahoma City, Oklahoma, serves as Trustee. Of these bonds, \$6,360,000 are outstanding as of May 1, 1977. The proceeds of these bonds were used by the University to make Phase III and IV additions to the Steam and Chilled Water Plant (the "Plant") at the Oklahoma Health Center (the "Center") in Oklahoma City, Oklahoma, to fund capitalized debt service, the Bond Fund Reserve Account and the Repair and Replacement Fund, and to pay expenses incurred in connection with the issuance of the Series 1975 Bonds. The University

has determined that a refunding of the Series 1975 Bonds is in its best interest to obtain significant savings in total debt service payable on the Series 1975 Bonds which savings will benefit the University and other entities at the Center using the Central Steam and Chilled Water Plant System. Consequently, the University proposes to advance refund the Series 1975 Bonds and to effect a discharge of the lien of the 1975 Supplemental Bond Resolution. The proceeds received from the sale of the Special Obligation Bonds and the proceeds received from the sale of the Revenue Bonds will be used to effect the advance refunding.

Simultaneously with the issuance of the Special Obligation Bonds, the University will issue \$6,850,000 Utility System Revenue Refunding Bonds, Series 1977, dated July 1, 1977, pursuant to a 1977 Supplemental Bond Resolution dated as of July 1, 1977, under which the Bank is Trustee. The Revenue Bonds will provide, among other things, a portion of the monies necessary to effect the advance refunding. More detailed information concerning the Revenue Bonds, the security for such bonds and the use of the proceeds thereof is provided in the Official Statement of the University specifically relating to the Revenue Bonds, copies of which are available from the University or the Underwriters of these Special Obligation Bonds, who are also the Underwriters of the Revenue Bonds.

The monies required to refund the Series 1975 Bonds will come from the net proceeds of the Special Obligation Bonds and the Revenue Bonds. The net proceeds of these two series of bonds will be used to purchase direct and general obligations of the United States of America, specifically United States Treasury Obligations, State and Local Government Series (the "Government Securities") in an aggregate principal amount of \$10,424,000. The Government Securities will bear interest and mature at such time and in such amounts that sufficient monies will be available from the Government Securities for the following purposes:

- A. To pay, when due and payable, all principal of and interest on the outstanding Series 1975 Bonds to and including January 1, 1986; and
- B. To redeem at January 1, 1986, the \$5,415,000 principal amount of the then outstanding Series 1975 Bonds at a redemption price of 104% of the principal amount being redeemed (the Series 1975 Bonds maturing January 1, 1986 and thereafter are subject to optional redemption from January 1, 1985 to December 31, 1987 at a redemption price of 104% of principal amount, plus accrued interest to the date fixed for redemption); and
- C. After the satisfaction of the principal and interest requirements of the Series 1975 Bonds, to pay, when due and payable, the principal of and interest on the Special Obligation Bonds to and including January 1, 1986. No revenues or properties of the Plant pledged under the 1977 Supplemental Bond Resolution are available to pay the principal of or interest on the Special Obligation Bonds.



In the opinion of Bond Counsel, under Oklahoma law, Bonds refunded by the University must be redeemed within ten (10) years of the date of issuance of refunding bonds. The Government Securities will be held in a Refunding Escrow Account by the Bank as Escrow Agent pursuant to a Refunding Escrow Agreement between the University and the Bank dated as of July 1, 1977 (the "Refunding Escrow Agreement")

The Government Securities will be purchased by the University from the Treasury Department of the United States of America with interest rates which will cause the actuarial yield thereon (computed in accordance with the provisions of Section 103(c) of the Internal Revenue Code of 1954, as amended (the "Code"), and the regulations applicable thereto) not to exceed the actuarial yield on the Special Obligation Bonds and the Revenue Bonds, treating the Special Obligation Bonds and the Revenue Bonds as a single issue of refunding bonds in the computation of the yield.

The University has also issued \$10,125,000 principal amount Utility System Revenue Bonds, Series 1973, dated July 1, 1973, (the "Series 1973 Bonds"), on September 12, 1973, pursuant to a Bond Resolution (the "Series 1973 Bond Resolution"), dated as of July 1, 1973, under which The First National Bank and Trust Company of Oklahoma City, Oklahoma City, Oklahoma, serves as Trustee. Of these Bonds, \$9,590,000 are outstanding as of July 1, 1977. The proceeds of the Series 1973 Bonds were used by the University to acquire the original Phase I of the Plant from the Oklahoma University Development Authority, to make Phase II additions to the Plant, to fund capitalized debt service, the Bond Fund Reserve Account and the Repair and Replacement Fund, and to pay expenses incurred in connection with the issuance of the Series 1973 Bonds. The Series 1973 Bonds are not being advance refunded. The Revenue Bonds will be equally and ratably secured with the Series 1973 Bonds.

## THE SPECIAL OBLIGATION BONDS

### DESCRIPTION OF THE BONDS

The Special Obligation Bonds are issued in the form of coupon bonds in the denomination of \$5,000 registrable as to principal only, or in fully registered form in the denomination of \$5,000 or with respect to principal maturing on the same date in any multiple thereof, are dated July 1, 1977, and will mature serially on each January 1 and July 1 from January 1, 1978 to January 1, 1986, inclusive. The Special Obligation Bonds will be issued in the principal amounts and bear interest at the rates set forth on page 4 of this Official Statement. The principal of and semi-annual interest (January 1 and July 1, first coupon payable January 1, 1978) are payable at the Bank or at the option of the Bondholder at the Fiscal Agency of the State of Oklahoma in the City of New York, New York, or in the event of the discontinuance of that Agency, then at The Chase Manhattan Bank (National Association), New York, New York.

### REDEMPTION PROVISIONS

The Special Obligation Bonds are not subject to redemption prior to maturity.

## SECURITY FOR THE BONDS

The Special Obligation Bonds are special obligations of the University secured by and payable solely from the maturing principal of and interest earned on the Government Securities after such funds are first used to pay the principal of and interest on the Series 1975 Bonds. The Government Securities are required to be deposited in a Refunding Escrow Account pursuant to the Refunding Escrow Agreement between the University and the Bank, as Escrow Agent. The Refunding Escrow Agreement and the Special Obligation Bond Resolution provide that the University pledges to the Bank, as Escrow Agent, all the rights of the University to the maturing principal and interest income paid on the Government Securities in excess of the amount required to make the payments of the principal of and interest on the Series 1975 Bonds, for the payment of principal of and interest on the Special Obligation Bonds.

The Refunding Escrow Agreement requires the Bank, as Escrow Agent, to deposit, when received, the maturing principal and interest income earned on the Government Securities, first, into the Series 1975 Bond Account created under the Refunding Escrow Agreement, sufficient funds to pay the principal of interest on the Series 1975 Bonds, and after the satisfaction of the principal and interest requirements of the Series 1975 Bonds, into the Special Obligation Bond Account created under the Refunding Escrow Agreement sufficient funds to pay the principal of and interest on the Special Obligation Bonds. The principal of the Government Securities is in an amount calculated to be sufficient to pay the principal of and interest on the Series 1975 Bonds. A detailed estimate of the interest income to be earned on the Government Securities is provided in Exhibit B.

The Special Obligation Bonds are not an indebtedness of the State of Oklahoma, the University or the Board of Regents, but are special obligations payable solely from the maturing principal and interest earned on the Government Securities in excess of the amount required to make the payments of the principal of and interest on the Series 1975 Bonds which are being refunded and monies deposited pursuant to the Refunding Escrow Agreement at the time of delivery of the Special Obligation Bonds.

## ADDITIONAL BONDS

The Special Obligation Bond Resolution does not provide for the issuance of additional bonds thereunder.

## RISKS OF BONDHOLDERS

The net proceeds derived from the issuance of the Special Obligation Bonds and the Revenue Bonds were utilized to purchase Government Securities, the principal of which, when due, will provide sufficient monies, when combined with any initial cash balances, to retire the principal and interest on the outstanding Series 1975 Bonds of the University due January 1, 1978 through and including January 1, 1986 and on January 1, 1986 to redeem the then outstanding balance of the Series 1975 Bonds including the payment of the redemption premium. The principal and interest received from such investment in the Government Securities, shall be utilized to

retire the Series 1975 Bonds in such manner and to pay the principal and interest on the Special Obligation Bonds. The Special Obligation Bonds shall be dependent upon the receipt of sufficient monies to first satisfy the principal and interest requirements of the Series 1975 Bonds. The primary risk of the holders of the Special Obligation Bonds shall be the failure of the United States Government to pay the principal and interest on the Government Securities.

#### USE OF BOND PROCEEDS

The University estimates the funds needed to advance refund the Series 1975 Bonds and to pay the expenses in connection with the Special Obligation Bonds and the Revenue Bonds and the sources of those funds to be as follows:

#### SOURCES OF FUNDS

Principal Amount of Revenue Bonds	\$ 6,850,000.00
Principal Amount of Special Obligation Bonds	3,705,000.00
Contribution to Escrow Account	<u>0.00</u>
	<u>\$10,555,000.00</u>

#### USE OF FUNDS

Total Principal Requirements of Series 1975 Bonds	\$ 6,360,000.00
Total Interest Requirements of Series 1975 Bonds from July 1, 1977 to January 1, 1986	3,847,643.75
Call premium payable on January 1, 1986 (4% of \$5,415,000)	<u>216,600.00</u>
Total Series 1975 Resolution Requirements	\$10,424,243.75
Legal, Financial and Expenses	<u>130,756.25</u>
	<u>\$10,555,000.00</u>

#### SUMMARY OF CERTAIN PROVISIONS OF THE SPECIAL OBLIGATION BOND RESOLUTION

The following is a summary of certain provisions of the Special Obligation Bond Resolution which authorizes the University to issue the Special Obligation Bonds and which shall be by and between the University and the Bank. Reference is made to the Special Obligation Bond Resolution for a complete recital of its terms and provisions.

## APPLICATION OF THE SPECIAL OBLIGATION BOND PROCEEDS

The proceeds, including accrued interest, received on the delivery of and payment for the Special Obligation Bonds shall be applied by the University as follows:

- A. The accrued interest shall be deposited in the Special Obligation Bond Account, as defined hereinafter, and shall be used only for the purpose of paying interest becoming due on the Special Obligation Bonds.
- B. The University shall pay all costs and expenses in connection with the preparation, issuance, and sale of the Special Obligation Bonds.
- C. The remainder of the proceeds shall be transferred to the Refunding Escrow Account (the "Refunding Escrow Account") established pursuant to the Refunding Escrow Agreement and maintained with the Bank to be combined with the net proceeds of the Revenue Bonds to acquire Government Securities which shall mature as to principal and interest at such times to be sufficient to pay the principal of and interest on the Series 1975 Bonds and the Special Obligation Bonds, as the same shall become due and to redeem the Series 1975 Bonds including the payment of the redemption premium on January 1, 1986.

At the time of the execution of the Refunding Escrow Agreement, the University shall furnish to the Bank appropriate documentation to demonstrate that the sums being deposited and the investments to be made will be sufficient for such purposes.

The Refunding Escrow Account shall be kept separate and apart from all other funds of the University and the monies on deposit therein shall be irrevocably appropriated, withdrawn, used and applied by the Bank solely for the purposes set forth in the Refunding Escrow Agreement. All such proceeds shall constitute trust funds for such purposes until so applied.

No use will be made of the proceeds of the Special Obligation Bonds which would cause the same to be "arbitrage bonds" within the meaning of the Code. The University at all times, while the Special Obligation Bonds and interest thereon are outstanding, will comply with the requirements of Section 103(c) of the Code and any valid and applicable rules and regulations of the Internal Revenue Service issued thereunder.

## DISPOSITION OF ESCROW INCOME AND ACCRUED INTEREST

The accrued interest received upon delivery of and payment for the Special Obligation Bonds shall be deposited into the Special Obligation Bond Account maintained with the Bank. As received, the maturing principal and interest of the Government Securities received pursuant to the Refunding Escrow Agreement shall be deposited into the Refunding Escrow Account maintained with the Bank. Such maturing principal and interest shall be irrevocably appropriated and utilized to transfer as follows:

- A. To the Series 1975 Bond Account created in the Refunding Escrow Account, (the "Series 1975 Bond Account"), amounts sufficient to satisfy the principal and interest requirements of the Series 1975 Bonds and to redeem the Series 1975 Bonds, including the payment of the redemption premium on January 1, 1986 and after satisfaction of the periodic payment of principal of and interest on the Series 1975 Bonds then;
- B. To the Special Obligation Bond Account created in the Refunding Escrow Account, (the "Special Obligation Bond Account"), relating to the Special Obligation Bonds amounts sufficient to satisfy the principal and interest requirements of the Special Obligation Bonds.

After satisfaction of the Series 1975 Bonds periodic principal and interest requirements, all maturing principal and interest on the Government Securities shall be dispersed by the Bank prior to each interest payment date and principal payment date only in the following manner and order of priority:

- A. There shall be paid to the paying agents a sum equal to the amount of interest which will become due and payable on the Special Obligation Bonds on the next interest payment date, and a sum equal to the amount of principal on the Special Obligation Bonds which will become due and payable on such date. Such payments in addition shall also include all handling charges of the paying agents.
- B. Thereafter, any monies remaining on deposit in the Special Obligation Bond Fund, after all required payments provided above have been made in full, shall next be applied to the payment of expenses of the Bank, as provided in the Refunding Escrow Agreement. Any remaining monies after the total principal and interest requirements of the Series 1975 Bonds, including the redemption thereof, and the Special Obligation Bonds have been paid in accordance with their terms shall be deposited into the Revenue Fund created by the Series 1973 Bond Resolution and applied as therein provided for the payment of the Revenue Bonds and the interest thereon.

#### SECURITY FOR DEPOSITS

All such special Accounts and Funds hereinabove provided, and all other funds created and established pursuant to the Special Obligation Bond Resolution, shall constitute trust funds for the purpose provided herein. All uninvested cash balances of such accounts and funds shall be continuously secured in the same manner as are deposits of uninvested sinking funds of political subdivisions of the State of Oklahoma; provided, however, that the obligations securing such accounts and funds shall be at all times equal in market value to the amount of monies in such Accounts and Funds.

Monies on deposit in the Series 1975 Bond Account and the Special Obligation Bond Account shall not be invested at any time.

## PARITY BONDS

The University will not issue any other obligations, payable from the maturing principal of and interest on the Government Securities nor voluntarily create or cause to be created any debt, lien, pledge, assignment, encumbrance or other charge upon the Refunding Escrow Account having priority to or being on a parity with the lien on the Special Obligation Bonds issued pursuant to the Special Obligation Bond Resolution.

## MODIFICATION OR AMENDMENT

No material modification or amendment of the Special Obligation Bond Resolution or of any resolution amendatory thereto or supplemental thereto, may be made without the consent in writing of the holders of two-thirds or more in principal amount of the Special Obligation Bonds then outstanding; provided, however, that no modification or amendment shall permit a change in the maturity of such Special Obligation Bonds or a reduction in the rate of interest thereon, or in the amount of the principal obligation, or to pay the principal of and interest on the Special Obligation Bonds as the same shall become due from the maturing principal of and interest on the Government Securities or reduce such percentage of holders of such Special Obligation Bonds, required above, for such modifications or amendments, without the consent of all of the holders of such Special Obligation Bonds.

## DEFEASANCE

If, at any time, the University shall have paid the principal and interest of the Special Obligation Bonds, then the pledge of and lien on the Government Securities in favor of the holders of the Special Obligation Bonds shall be no longer in effect.

## REMEDIES

Any holder of Special Obligation Bonds or of any coupons appertaining thereto, issued under the provisions of the Special Obligation Bond Resolution or any trustees acting for the holders of such Special Obligation Bonds may either at law or in equity, by suit, action, mandamus or other proceeding in any court of competent jurisdiction, protect and enforce any and all rights, including the right to the appointment of a receiver, existing under the laws of the State of Oklahoma, of the United States of America or granted and contained in the Special Obligation Bond Resolution and may enforce and compel the performance of all duties required by the Special Obligation Bond Resolution and may enforce and compel the performance of all duties required by the Special Obligation Bond Resolution or by any applicable statutes to be performed by the University or by any officer thereof.

Nothing herein, however, shall be construed to grant to any holder of such Special Obligation Bonds any lien on any properties of the University other than provided herein.

## SUMMARY OF CERTAIN PROVISIONS OF THE REFUNDING ESCROW AGREEMENT

A Refunding Escrow Agreement will be entered into by and between the University and the Bank dated as of July 1, 1977. The following summary of certain provisions of the Refunding Escrow Agreement does not purport to be complete and for the complete provisions of the agreement, reference is made to the Refunding Escrow Agreement. The Refunding Escrow Agreement is in no way security for the Revenue Bonds.

A Refunding Escrow Account shall be established with the Bank pursuant to the Refunding Escrow Agreement for the benefit of the holders of the Series 1975 Bonds and the Special Obligation Bonds.

The University shall deposit in the Refunding Escrow Account, from the proceeds of the Revenue Bonds and the Special Obligation Bonds, monies sufficient to acquire Government Securities in an amount sufficient and maturing in such amounts of principal and interest which shall be sufficient to pay the principal of and interest on the Series 1975 Bonds when due until January 1, 1986; to redeem the outstanding balance of the Series 1975 Bonds, including the payment of the redemption premium on January 1, 1986; and to pay the principal of and interest on the Special Obligation Bonds when due. The funds deposited in the Refunding Escrow Account shall constitute an irrevocable appropriation of monies for the benefit of the Series 1975 Bonds and the Special Obligation Bonds.

The principal and interest of the Government Securities shall be deposited, irrevocably pledged and shall be utilized to transfer, (i) to the Series 1975 Bond Account amounts sufficient to satisfy the debt service requirements of such Series 1975 Bonds until January 1, 1986 and to redeem the outstanding principal amount of the Series 1975 Bonds, including the payment of the redemption premium, on January 1, 1986 and after satisfaction of the periodic debt service requirements on the Series 1975 Bonds then (ii) to the Special Obligation Bond Account relating to the Special Obligation Bonds amounts sufficient to satisfy the principal and interest requirements of such Special Obligation Bonds when due.

No substitutions for the Government Securities initially purchased with the net proceeds of the Revenue Bonds and the Special Obligation Bonds shall be allowed.

The University shall pay the proper fees and expenses to the Bank either from amounts in excess of the required amounts which will satisfy the principal and interest requirements on the Revenue Bonds and Special Obligation Bonds, or from other legally available sources of the University. Under no circumstances shall the Bank have a lien or a right to any monies or Government Securities held in the Refunding Escrow Account for the payment of such fees and expenses.

The Bank may resign and be discharged from the trusts created by the Refunding Escrow Agreement by giving proper notice in writing to the University. The Bank may be removed at any time by an instrument in writing, executed by the holders of not less than fifty-one percent (51%) in aggregate principal amount of the Series 1975 Bonds then outstanding and by the holders of not less than fifty-one percent

(51%) in aggregate principal amount of the Special Obligation Bonds then outstanding; such instruments to be filed with the University and proper notice to be given. The Bank may also be removed at any time for any breach of trust or for acting or proceeding in violation of, or for failing to act or proceed in accordance with, any provisions of the Refunding Escrow Agreement with respect to the duties and obligations of the Bank by any court of competent jurisdiction upon the application of the University or the holders of not less than five percent (5%) in aggregate principal amount of the Special Obligation Bonds then outstanding or the holders of not less than five percent (5%) in aggregate principal amount of the Series 1975 Bonds then outstanding.

The Refunding Escrow Agreement shall terminate when the principal and interest of the Series 1975 Bonds and the Special Obligation Bonds have been paid.

#### CERTIFICATION OF MATHEMATICAL COMPUTATIONS

The accuracy of mathematical computations of the adequacy of (i) the maturing principal and interest amounts of the Government Securities to pay all of the principal of and interest on the Series 1975 Bonds which become due on or before January 1, 1986, and to redeem on January 1, 1986, the Series 1975 Bonds which become due after that date at a redemption price of 104% of their principal amount and (ii) the maturing principal of and interest earned on the Government Securities, together with any monies deposited into the Refunding Escrow Account established under the Refunding Escrow Agreement, to also pay, when due, all of the principal of and interest on the Special Obligation Bonds, and (iii) the accuracy of mathematical computations supporting the conclusion that the Special Obligation Bonds are not "arbitrage bonds" under Section 103(c) of the Code, will be verified by a nationally recognized firm of independent certified public accountants. Such verifications will be based, among other things, upon mathematical computations supplied by the Underwriters in connection with the above matters.

#### PRESENTLY OUTSTANDING BONDS

The statement of the outstanding bonds of the University as of the month of March, 1977 is shown in Exhibit C. All bonds have been issued as revenue bonds. Most bonds have been issued for student housing projects or for student facilities.

As is shown in Exhibit C, as of the month of March, 1977, the University had outstanding bonds of \$48,231,000. Restricted funds totalled \$11,542,081, leaving outstanding bonds less total restricted funds equal to \$36,688,919 for the University.

#### UNDERWRITING

The Special Obligation Bonds will be purchased from the University at a price of par plus accrued interest, if any, for reoffering by the Underwriters, \_\_\_\_\_ . The Bond Purchase Contract provides that the Underwriters will purchase all the Special Obligation Bonds if any are purchased. The Underwriters reserve the right to join with securities dealers and other underwriters in offering the Special Obligation Bonds to the public and may offer and sell the Special Obligation Bonds to certain dealers and others at prices lower than the public offering



price stated on page 4 hereof. The initial public offering price may be changed from time to time by the Underwriters.

#### LEGAL OPINIONS AND TAX EXEMPTION

The unqualified approving opinion of Fagin, Brown, Bush, Selvidge & Tinney, Oklahoma City, Oklahoma, Bond Counsel, shall state that the interest earned on the Special Obligation Bonds is exempt from existing Federal and State of Oklahoma Income Taxes under existing statutes, regulations and court decisions. Bond Counsel will render a separate opinion that the Special Obligation Bonds are not "arbitrage bonds" as defined in Section 103(c) of the Code and regulations promulgated thereunder.

A transcript of the legal proceedings approved by the Attorney General of the State of Oklahoma, including a certificate that there is no litigation pending affecting the Special Obligation Bonds, and other closing papers shall be furnished to the Underwriters.

#### NO LITIGATION

There is not currently any pending legal proceeding or legal proceedings against the University, which in the aggregate are material, nor is there any litigation against the University which would restrain or enjoin the issuance or delivery of the Special Obligation Bonds or questioning or affect the validity of the Special Obligation Bonds or the proceedings and authority under which they are to be issued. Neither the creation, organization or existence, of the University nor the title of the current members of the Board of Regents, or other officers of the University to their respective offices is being questioned. There is no litigation pending against the University to enter into the Special Obligation Bond Resolution or to secure the Special Obligation Bonds in the manner provided in the Special Obligation Bond Resolution or the method used in the refunding program.

#### RATINGS

As noted on page 3 of this Official Statement, Moody's Investor Service, Inc., and Standard & Poor's Corporation have given the Special Obligation Bonds the ratings of \_\_\_\_\_ and \_\_\_\_\_, respectively. Such ratings reflect only the respective views of such organizations and an explanation of the significance of such ratings may be obtained from the rating agency furnishing the same. There is no assurance that such ratings will continue for any given period of time or that they will not be revised downward or withdrawn entirely by either or both of such rating agencies if, in the judgment of either or both, circumstances so warrant. Any such downward revision or withdrawal of such ratings, or either of them, may have an adverse effect on the market price of the Special Obligation Bonds.

## MISCELLANEOUS

The references to and excerpts of the Special Obligation Bond Resolution and Refunding Escrow Agreement contained in this Official Statement are merely summaries of certain provisions thereof and do not purport to be the complete provisions of those documents. Copies of such documents are available from the University or the Underwriters.

Any statements in this Official Statement and Exhibits hereto involving estimates or assumptions, whether or not expressly so stated, are intended as such and no representation whatsoever is made that such estimates or assumptions are correct or will be realized. So far as any statements are made in this Official Statement and Exhibits attached hereto involving matters of opinion, whether or not expressly so stated, they are intended as such and not as representations of fact. Neither this Official Statement, nor any statement that may have been made orally or in writing, is to be construed as a contract with the purchasers or holders of any of the Special Obligation Bonds.

All information contained in this Official Statement and Exhibits is subject to change and/or correction without notice and neither the delivery of the Official Statement nor any sale made hereunder shall create any implication that the information contained herein is complete or accurate in its entirety as of any date after the date hereof.

Reference is made to Exhibits A, B and C which are an integral part of this Official Statement and must be read together with the rest of this Official Statement.

---

The Official Statement has been approved by the Board of Regents.

BOARD OF REGENTS OF THE UNIVERSITY  
OF OKLAHOMA

By: Thomas R. Brett, President

Exhibit A

FUNDING OF DEBT SERVICE REQUIREMENTS

REGENTS OF THE UNIVERSITY OF OKLAHOMA

UTILITY SYSTEM SPECIAL OBLIGATION REFUNDING BONDS  
SERIES 1977

This Exhibit shows the application of the interest income to be earned on the Government Securities which is calculated to fully fund and to pay the total principal and interest requirements of the Special Obligation Bonds.

<u>Period Ending</u>	<u>Interest Earned on Government Securities</u> <sup>1/</sup>	<u>Interest Payments</u>	<u>Principal Payments</u>	<u>Cumulative Surplus</u>
1-1-78				
7-1-78				
1-1-79				
7-1-79				
1-1-80				
7-1-80				
1-1-81				
7-1-81				
1-1-82				
7-1-82				
1-1-83				
7-1-83				
1-1-84				
7-1-84				
1-1-85				
7-1-85				
1-1-86				

<sup>1/</sup> See Exhibit B for calculation of interest income to be earned.

Exhibit B

MATURING PRINCIPAL OF AND INTEREST  
EARNED ON GOVERNMENT SECURITIES

<u>Date</u>	<u>Yield</u>	<u>Maturing Principal</u> /	Interest Earned on Government <u>Securities</u> /
-------------	--------------	---------------------------------	---

Exhibit C

UNIVERSITY OF OKLAHOMA - NORMAN CAMPUS AND HEALTH SCIENCES CENTER  
STATEMENT OF OUTSTANDING BONDS  
March 31, 1977

<u>Bond Issue</u>	<u>Length of Issue</u>	<u>Bond Principal</u>		<u>Restricted Funds</u>				<u>Percent Invested</u>	<u>Outstanding Less Total Restricted</u>
		<u>Original Amount</u>	<u>Outstanding</u>	<u>Principal &amp; Interest</u>	<u>Reserve</u>	<u>Repair &amp; Replacement</u>	<u>Total</u>		
<u>Student Housing Revenue Bonds:</u>									
1957 Bond System:									
Series A and B (1957)	40	\$ 6,541,000	\$ 1,505,000	\$ 446,704	\$ 764,136	\$ 31	\$ 1,210,871	79	\$ 294,129
Series C (OCCE 1959)	30	1,400,000	877,000	1,445	313,710	--	315,155	98	561,845
1963-64 Bond System:									
Series A and B (1963)	40	5,700,000	4,639,000	279,434	724,997	591,969	1,596,400	99	3,042,600
Series C (1964)	39	3,000,000	2,635,000	174,015	467,366	406,738	1,048,119	99	1,586,881
1966 Bond System	33	13,600,000	12,495,000	1,023,439	997,456	515,956	2,536,851	99	9,958,149
<u>Student Facilities Revenue Bonds:</u>									
Series D (1963)	15	1,800,000	375,000	6,491	327,267	--	333,758	98	41,242
Series A (1971)	15	1,760,000	1,330,000	11,252	273,102	77,692	362,046	99	967,954
Series B (1971)	25	4,000,000	4,000,000	37,600	454,934	65,719	558,253	99	3,441,747
<u>Oklahoma Memorial Union Bonds</u>	30	2,300,000	332,000	121,917	174,924	--	296,841	99	35,159
<u>Stadium System Revenue Bonds</u>	15	5,000,000	3,500,000	366,803	473,950	--	840,753	99	2,659,247
<u>Organized Group Housing:</u>									
Series 1 (PKP)	30	220,000	169,000	--	49,498	20,224	69,722	92	99,278
Series 2 (SAE)	30	340,000	279,000	21,628	40,000	2,553	64,181	91	214,819
<b>TOTAL NORMAN CAMPUS</b>		<u>\$45,661,000</u>	<u>\$32,136,000</u>	<u>\$2,490,728</u>	<u>\$5,061,340</u>	<u>\$1,680,882</u>	<u>\$ 9,232,950</u>		<u>\$22,903,050</u>
<u>Utility System Revenue Bonds:</u>									
Series 1973	30	\$10,125,000	\$ 9,735,000	\$ 283,362	\$ 997,810	\$ 100,000	\$ 1,381,172	99	\$ 8,353,828
Series 1975	30	6,500,000	6,360,000	179,509	648,450	100,000	927,959	99	5,432,041
<b>TOTAL HEALTH SCIENCES CENTER</b>		<u>\$16,625,000</u>	<u>\$16,095,000</u>	<u>\$ 462,871</u>	<u>\$1,646,260</u>	<u>\$ 200,000</u>	<u>\$ 2,309,131</u>		<u>\$13,785,869</u>
<b>TOTAL BOTH CAMPUSES</b>		<u>\$62,286,000</u>	<u>\$48,231,000</u>	<u>\$2,953,599</u>	<u>\$6,707,600</u>	<u>\$1,880,882</u>	<u>\$11,542,081</u>		<u>\$36,688,919</u>

Note: No accrued interest payable or receivable is included in the bonds outstanding and restricted funds totals.

PROPOSED REVENUE REFUNDING BOND ISSUE  
CENTRAL STEAM AND CHILLED WATER FACILITIES

OFFICIAL STATEMENT

REGENTS

OF THE

UNIVERSITY OF OKLAHOMA

UTILITY SYSTEM REVENUE REFUNDING BONDS, SERIES 1977

Submitted for Consideration of the  
Oklahoma State Regents For Higher Education

May 23, 1977

The Bonds are offered only by means of this Official Statement. This Official Statement does not constitute an offering of any security other than the Bonds specifically offered hereby. It does not constitute an offer to sell or a solicitation of an offer to buy the Bonds in any State or jurisdiction to any person to whom it is unlawful to make such offer, solicitation or sale, and no dealer, broker, salesman or other person has been authorized to make such unlawful offer, solicitation or sale. No dealer, broker, salesman or other person has been authorized to give any information or to make any representations other than those contained in the Official Statement in connection with the offering of the Bonds and, if given or made, such other information or representations must not be relied upon.

---

TABLE OF CONTENTS

	Page
The University of Oklahoma - Board of Regents and University Officials . . . . .	3
Description . . . . .	4
Maturity Schedule . . . . .	4
The University of Oklahoma and the Board of Regents . . . . .	5
Plan of Financing . . . . .	5
The Bonds . . . . .	7
Description of the Bonds . . . . .	7
Redemption Provisions . . . . .	8
Security for the Bonds . . . . .	9
Additional Bonds . . . . .	9
Risks of Bondholders . . . . .	9
Use of Bond Proceeds . . . . .	10
The Plant . . . . .	10
Utility Service Agreements . . . . .	12
Control Service Agreements . . . . .	13
Customers of the Plant . . . . .	13
Summary of Certain Provisions of the Bond Resolution . . . . .	15
The 1977 Supplemental Bond Resolution . . . . .	24
The University of Oklahoma . . . . .	25
Presently Outstanding Bonds . . . . .	30
Underwriting . . . . .	31
Legal Opinions and Tax Exemption . . . . .	31
No Litigation . . . . .	31
Ratings . . . . .	31
Miscellaneous . . . . .	32

Exhibits

A - Annual Debt Service Requirements

B - Statement of Debt Service Requirements on Series 1973 and Series  
1977 Bonds

Exhibits (Continued)

- C - General Description of Central Steam and Chilled Water Plant
- D - Form of Utility Service Agreement
- E - Form of Control Service Agreement
- F - (To be supplied)
- G - Form of Engineers Certification
- H - Accountants' Report on Financial Statements and Financial Statements
- I - The University of Oklahoma Statement of Outstanding Bonds

---

The Bonds are offered when, as and if issued and received by the Underwriters, subject to prior sale, to withdrawal or modifications of the offer without any notice, and to the approval of legality of the Bonds by Fagin, Brown, Bush, Selvidge & Tinney, Oklahoma City, Oklahoma, Bond Counsel. It is expected that the Bonds in definitive form will be available for delivery to the Underwriters in \_\_\_\_\_, \_\_\_\_\_, on or about \_\_\_\_\_.

(This space intentionally left blank)



THE UNIVERSITY OF OKLAHOMA

BOARD OF REGENTS

Mr. Thomas R. Brett, Tulsa  
President

Mr. Richard A. Bell, Norman

Bob G. Mitchell, M.D., Sallisaw  
Vice President

Mr. Dee A. Replogle, Jr., Oklahoma City

Mr. Charles E. Engleman, Clinton

Mr. K. D. Bailey, Okmulgee

Ronald H. White, M. D., Oklahoma City

UNIVERSITY OFFICIALS INCLUDE

Dr. Paul F. Sharp, President

William G. Thurman, M.D., Provost, Health Sciences Center

Dr. Gene M. Nordby, Vice President for Administration & Finance

UNIVERSITY COUNSEL

Mr. Thomas H. Tucker, Chief Counsel

ENGINEERS

Carnahan-Thompson-Delano, Inc.,  
Oklahoma City, Oklahoma

BOND COUNSEL

Fagin, Brown, Bush, Selvidge & Tinney,  
Oklahoma City, Oklahoma

FINANCIAL CONSULTANT

Leo Oppenheim & Co., Inc.  
Oklahoma City, Oklahoma

The information contained in this Official Statement has been compiled from sources believed to be reliable. The Official Statement contains estimates and matters of opinion which are not intended as representative of fact. This Official Statement is not to be construed as a contract with the purchasers of the Bonds.

THE DATE OF THE OFFICIAL STATEMENT IS \_\_\_\_\_, 1977.

Interest exempt, in the opinion of Bond Counsel, from all present Federal and State of Oklahoma Income Taxes under existing statutes, regulations and court decisions.

OFFICIAL STATEMENT

NEW ISSUE

Moody's: \_\_\_\_\_  
Standard & Poor's: \_\_\_\_\_

\$6,850,000 \*

REGENTS OF THE UNIVERSITY OF OKLAHOMA

UTILITY SYSTEM REVENUE REFUNDING BONDS, SERIES 1977

Dated: July 1, 1977

Due: January 1, as shown below

Principal and semi-annual interest (January 1 and July 1, first coupon payable January 1, 1978) are payable at The First National Bank and Trust Company of Oklahoma City, Oklahoma City, Oklahoma, (the "Bank"); or at the option of the holder thereof at the Fiscal Agency of the State of Oklahoma in the City of New York, New York; or in the event of the discontinuance of that Agency, then at The Chase Manhattan Bank (National Association), New York, New York. The Regents of the University of Oklahoma Utility System Revenue Refunding Bonds, Series 1977, (the "Bonds"), are issued in the form of coupon bonds in the denomination of \$5,000 each registrable as to principal only, or in fully registered form in \$5,000 denominations, or with respect to principal maturing on the same date, in multiples thereof. The Bonds are subject to redemption prior to maturity as described elsewhere herein. The Bonds are not an indebtedness of the State of Oklahoma, the University of Oklahoma, (the "University"), or the Board of Regents of the University of Oklahoma, (the "Board of Regents"), but are special obligations payable solely from certain pledged revenues of the Plant as hereinafter defined. The Bonds and the Board of Regent's \$3,705,000 Utility System Special Obligation Refunding Bonds, Series 1977, (the "Special Obligation Bonds"), which are being offered simultaneously with the Bonds under a separate Official Statement, are being issued to provide funds to advance refund the outstanding portion of the \$6,500,000 Board of Regents Utility System Revenue Bonds, Series 1975. These refunding Bonds are not equally or ratably secured with the Special Obligation Bonds.

MATURITY SCHEDULE

The Bonds are dated July 1, 1977, and are due on January 1 of each year and in the principal amounts as shown on the following page:

\* Approximate amount, subject to change.

\$3,080,000 Serial Bonds

<u>Maturity Date</u>	<u>Principal Amount</u>	<u>Interest Rate</u>	<u>Price or Yield</u>	<u>Maturity Date</u>	<u>Principal Amount</u>	<u>Interest Rate</u>	<u>Price or Yield</u>
1-1-78	\$100,000			1-1-87	\$170,000		
1-1-79	100,000			1-1-88	180,000 *		
1-1-80	105,000			1-1-89	190,000 *		
1-1-81	110,000			1-1-90	205,000 *		
1-1-82	120,000			1-1-91	220,000 *		
1-1-83	125,000			1-1-92	235,000 *		
1-1-84	135,000			1-1-93	245,000 *		
1-1-85	150,000			1-1-94	260,000 *		
1-1-86	150,000			1-1-95	280,000 *		

\$3,770,000 \* \_\_\_ % Term Bonds due January 1, 2005,  
subject to annual mandatory redemption by lot at  
par beginning January 1, 1996.

Price or Yield: \_\_\_\_\_

(Plus Accrued Interest)

\* Subject to optional redemption beginning January 1, 1987, as more fully described on page 8.

THE UNIVERSITY OF OKLAHOMA AND THE BOARD OF REGENTS

The University is a member of The Oklahoma State System of Higher Education that includes all collegiate institutions in Oklahoma supported wholly, or in part, by State appropriations. The government of the University is vested in the Board of Regents, a constitutional board of seven members appointed by the Governor of the State of Oklahoma for staggered seven year terms, subject to confirmation by the State Senate. Members of the Board of Regents are listed on Page 3 of this Official Statement. The Board of Regents issues bonds under the provisions of Title 70, Oklahoma Statutes, 1971, Sections 4001 to 4014, inclusive as amended.

PLAN OF FINANCING

The purpose of this Official Statement, including the Exhibits hereto, is to give certain essential facts relating to the Board of Regents and the University in connection with the offering of \$6,850,000 Regents of the University of Oklahoma, Utility System Revenue Refunding Bonds, Series 1977, dated July 1, 1977. The Bonds are issued pursuant to a 1977 Supplemental Bond Resolution dated as of July 1, 1977 under which the Bank is Trustee. The Bank is also serving as Trustee under the Special Obligation Bond Resolution securing the Special Obligation Bonds and as the Escrow Agent under the Refunding Escrow Agreement described herein.

The University issued \$6,500,000 principal amount Utility System Revenue Bonds, Series 1975 dated January 1, 1975, (the "Series 1975 Bonds"), on February 18, 1975, pursuant to a Supplemental Bond Resolution, (the "1975 Supplemental Bond Resolution") dated as of January 1, 1975, under which The First National Bank and Trust Company of Oklahoma City, Oklahoma City, Oklahoma, serves as Trustee. Of these bonds, \$6,360,000 are outstanding as of May 1, 1977. The proceeds of these bonds were used by the University to make Phase III and IV additions to: the Steam and Chilled Water Plant, (the "Plant"), at the Oklahoma Health Center, (the "Center"), in Oklahoma City, Oklahoma, to fund capitalized debt service, the Bond Fund Reserve Account and the Repair and Replacement Fund, and to pay expenses incurred in connection with the issuance of the Series 1975 Bonds. The University has determined that a refunding of the Series 1975 Bonds is in its best interest to obtain significant savings in total debt service payable on the Series 1975 Bonds which savings will benefit the University and other entities at the Center using the Central Steam and Chilled Water Plant System. Consequently, the University proposes to advance refund the Series 1975 Bonds and to effect a discharge of the lien of the 1975 Supplemental Bond Resolution. The proceeds received from the sale of the Special Obligation Bonds and the proceeds received from the sale of the Bonds will be used to effect the advance refunding.

Simultaneously with the issuance of the Bonds, the University will issue \$3,705,000 Utility System Special Obligation Refunding Bonds, Series 1977, dated July 1, 1977, pursuant to a Special Obligation Bond Resolution dated as of July 1, 1977, under which the Bank is Trustee. The Special Obligation Bonds will provide, among other things, a portion of the monies necessary to effect the advance refunding. More detailed information concerning the Special Obligation Bonds, the security for such bonds and the use of the proceeds thereof is provided in the Official Statement of the University specifically relating to the Special Obligation Bonds, copies of which are available from the University or the Underwriters of these Bonds, who are also the Underwriters of the Special Obligation Bonds.

The monies required to refund the Series 1975 Bonds will come from the net proceeds of the Special Obligation Bonds and the Bonds. The net proceeds of these two series of bonds will be used to purchase direct and general obligations of the United States of America, specifically United States Treasury Obligations, State and Local Government Series (the "Government Securities") in an aggregate principal amount of \$10,424,000. The Government Securities will bear interest and mature at such times and in such amounts that sufficient monies will be available from the Government Securities for the following purposes:

- A. To pay, when due and payable, all principal of and interest on the outstanding Series 1975 Bonds to and including January 1, 1986; and
- B. To redeem at January 1, 1986, the \$5,415,000 principal amount of the then outstanding Series 1975 Bonds at a redemption price of 104% of the principal amount being redeemed (the Series 1975 Bonds maturing January 1, 1986 and thereafter are subject to optional redemption from January 1, 1985 to December 31, 1987 at a redemption price of 104% of principal amount, plus accrued interest to the date fixed for redemption); and

- C. After the satisfaction of the principal and interest requirements of the Series 1975 Bonds, to pay, when due and payable, the principal of and interest on the Special Obligation Bonds to and including January 1, 1986. No revenues or properties of the Plant pledged under the 1977 Supplemental Bond Resolution are available to pay the principal of or interest on the Special Obligation Bonds.

In the opinion of Bond Counsel, under Oklahoma law, Bonds refunded by the University must be redeemed within ten (10) years of the date of issuance of refunding bonds. The Government Securities will be held in an Escrow Account by the Bank as Escrow Agent pursuant to a Refunding Escrow Agreement between the University and the Bank dated as of July 1, 1977, (the "Escrow Agreement").

The Government Securities will be purchased by the University from the Treasury Department of the United States of America with interest rates which will cause the actuarial yield thereon (computed in accordance with the provisions of Section 103(c) of the Internal Revenue Code of 1954, as amended, (the "Code"), and the regulations applicable thereto) not to exceed the actuarial yield on the Special Obligation Bonds and the Bonds, treating the Special Obligation Bonds and the Bonds as a single issue of refunding bonds in the computation of the yield.

The University has also issued \$10,125,000 principal amount Utility System Revenue Bonds, Series 1973, dated July 1, 1973, (the "Series 1973 Bonds"), on September 12, 1973, pursuant to a Bond Resolution, (the "Series 1973 Bond Resolution"), dated as of July 1, 1973, under which The First National Bank and Trust Company of Oklahoma City, Oklahoma City, Oklahoma, serves as Trustee. Of these Bonds, \$9,590,000 are outstanding as of July 1, 1977. The proceeds of the Series 1973 Bonds were used by the University to acquire the original Phase I of the Plant from the Oklahoma University Development Authority, to make Phase II additions to the Plant, to fund capitalized debt service, the Bond Fund Reserve Account and the Repair and Replacement Fund, and to pay expenses incurred in connection with the issuance of the Series 1973 Bonds. The Series 1973 Bonds are not being advance refunded. The Bonds will be equally and ratably secured with the Series 1973 Bonds.

## THE BONDS

### DESCRIPTION OF THE BONDS

The Bonds are issued in the form of coupon bonds in the denomination of \$5,000 registrable as to principal only, or in fully registered form in the denomination of \$5,000 or with respect to principal maturing on the same date in any multiple thereof, are dated July 1, 1977, and will mature serially on each January 1 from 1978 to January 1, 1995, inclusive, and will also mature as term bonds due January 1, 2005, subject to annual mandatory redemption beginning January 1, 1996. The Bonds will be issued in the principal amounts and bear interest at the rates set forth on page 5 of this Official Statement. The principal of and semi-annual interest (January 1 and July 1, first coupon payable January 1, 1978) are payable at the Bank or at the

option of the Bondholder at the Fiscal Agency of the State of Oklahoma in the City of New York, New York, or in the event of the discontinuance of that Agency, then at The Chase Manhattan Bank (National Association), New York, New York.

**REDEMPTION PROVISIONS**

The Bonds are not subject to redemption prior to July 1, 1987, except as described herein.

- A. Optional Redemption - The Bonds maturing in the years 1978 to 1987, inclusive, are not subject to redemption prior to maturity. The Bonds maturing in the year 1988 and thereafter are subject to redemption at the option of the Board of Regents, in whole at any time, or in part in inverse order of maturity and by lot within a maturity on any interest payment date, on and after July 1, 1987, at the respective redemption prices (expressed as percentages of principal amount) set forth below, plus, in each case, accrued interest to the date fixed for redemption.

<u>Redemption Dates</u> <u>(Dates Inclusive)</u>	<u>Redemption Price</u>
July 1, 1987 to June 30, 1989	103%
July 1, 1989 to June 30, 1992	102%
July 1, 1992 to June 30, 1995	101%
Thereafter prior to maturity	100%

- B. Mandatory Bond Fund Redemption - The Term Bonds are subject to mandatory redemption, in part by lot, on each January 1, beginning January 1, 1996, at the principal amount thereof and accrued interest, as shown below:

<u>Year</u>	<u>Amount</u>	<u>Year</u>	<u>Amount</u>
1996	\$285,000	2001	\$380,000
1997	310,000	2002	405,000
1998	325,000	2003	430,000
1999	340,000	2004	450,000
2000	365,000	2005	480,000

- C. Extraordinary Event Redemption - The Bonds are also subject to redemption prior to maturity in whole or in part at any time, in inverse order of maturities and by lot within a maturity, if such redemption is made: (i) from insurance proceeds; (ii) from expropriation awards; and (iii) from the proceeds of the sale of all or a part of the properties acquired and constructed by the Series 1973 and Series 1975 Bonds. In the event that such redemption is made in accordance with this provision, such redemption shall be made at the principal amount redeemed, the interest accrued thereon to the redemption date, and (i) if such redemption is made prior to July 1, 1987, a premium on each Bond so redeemed equal to one year's interest thereon; and (ii)

if such redemption is made on or after the first date upon which such Bond would otherwise be subject to redemption, the same premiums as set forth in paragraph A above.

#### SECURITY FOR THE BONDS

This issue of Bonds are a special obligation of the Board of Regents of the University of Oklahoma and are secured by a first lien and pledge of revenues of the Plant payable pari passu with the Series 1973 Bonds. The Plant is built upon land, rights-of-way and easements owned by the University of Oklahoma. The Board of Regents covenant in the Series 1973 Bond Resolution dated as of July 1, 1973, and the Trust Agreement dated July 26, 1973, between the University and the Bank, as supplemented by the 1977 Supplemental Bond Resolution, (collectively, the "Bond Resolution"), to impose and collect utility service charges for steam and chilled water produced by the Plant and per point charges for the computerized control system which shall be sufficient to permit the prompt payment of the Debt Service Requirements specified under the Bond Resolution.

As additional security, the Bank or the holder or holders of a specified percentage of the Bonds shall have the right to enter into possession of the Plant and to operate it until a default is remedied or until all bonded indebtedness related to the Plant is retired, whichever shall first occur.

The Board of Regents has irrevocably appropriated the Escrow Account created under the Escrow Agreement and all payments of principal and interest on the Government Securities to, first, the payment of principal of and interest on, when due and payable, the Series 1975 Bonds, and after satisfaction of the principal and interest requirements of the Series 1975 Bonds, to pay when due and payable, the principal of and interest on the Special Obligation Bonds. The maturing principal of and the interest earned on the Government Securities will not be available to pay the principal of or interest on the Bonds.

The Bonds are not an indebtedness of the State of Oklahoma, the University, or the Board of Regents, but are a special obligation payable pari passu with the Series 1973 Bonds solely from the pledged revenues of the Plant.

#### ADDITIONAL BONDS

The Bond Resolution provides that Additional Bonds may be issued by the Board of Regents without consent of the Bondholders if certain conditions are met. These conditions include, among other things, that the estimated net revenues to be derived from the Plant shall in the year following the initial use of Plant facilities be at least equal to the annual amount of debt service requirements on all bonds, including the Additional Bonds to be issued. Additional Bonds, if issued, would be equally secured with the Bonds offered hereby. There is no restriction on the issuance of junior lien or refunding bonds.

#### RISKS OF BONDHOLDERS

The factors described herein are not intended to be definitive or exhaustive, but rather are some factors an investor should consider, among other things, in deciding whether to purchase any of the Bonds.

and related facilities, the purchase and installation of two water chillers (1,000 ton and 2,000 ton capacities) and two steam boilers (totaling 120,000 pounds per hour steam capacity), the installation of two 3,000 ton cooler tower cells, the construction of 3,000 feet of concrete tunnels (distribution system) to service initial customers, and service facilities. This construction was completed and put into active service on April 30, 1972.

## PHASE II

Prior to proceeding with Phase II additions to the Plant, the Board of Regents determined that it was in the best interest of the University of Oklahoma and the State of Oklahoma that they acquire the then present facilities before proceeding with the Phase II program. Accordingly, the Plant was purchased from the Oklahoma University Development Authority from a portion of the proceeds of the \$10,125,000 Board of Regents of the University of Oklahoma Utility System Revenue Bonds, Series 1973, which were sold on July 26, 1973 and were delivered on September 12, 1973. Title to the Plant passed from the Oklahoma University Development Authority to the Board of Regents on September 12, 1973. The remaining portion of the Series 1973 Bonds, less fees and expenses, funded Phase II additions to the Plant which provided steam and chilled water and a computerized control system to Presbyterian Hospital and other major buildings at the Center with the addition to the Plant of approximately 3,400 feet of tunnels constructed and one 3,000 ton steam turbine driven water chilling unit and one 60,000 pounds per hour boiler.

## PHASE III

Phase III additions to the Plant provided the addition to the Plant of construction of a 100' x 100' addition to the building; installation of one 60,000 pounds per hour boiler, one 3,000 ton steam turbine driven water chilling unit with appurtenances, one deaerating heater with boiler feed pump and miscellaneous appurtenances, and one 500 ton motor driven chiller with pumps; and tunnel extensions to new customers. These additions provided greater capacity to serve the expansion of Oklahoma Children's Memorial Hospital, and the University's Bio-Medical Sciences Building and Dental Sciences Building.

## PHASE IV

Phase IV additions to the Plant provided the additions to the Plant of one 60,000 pounds per hour boiler, one 3,000 ton steam turbine driven water chilling unit with appurtenances and construction of a water well. This expansion served the University's College of Nursing Building, the McGee Eye Institute and will provide for the University's Library and Learning Resources Center. This phase was completed in 1976.

## FUEL FOR THE PLANT

Natural gas is the basic fuel for the Plant. The gas is supplied by Oklahoma Natural Gas Company under a contract that was for an original term of five (5) years from April 25, 1972. Since the expiration of the original term, the contract is renewable from year to year and may be terminated at the expiration of any yearly renewal by



either party on 30 days written notice. The contract provides for an automatic adjustment for cost of purchased gas and taxes. The contract is one of "first interruptible" service. The Plant can readily be converted to fuel oil for emergency, alternate or continuous use. There is buried storage of approximately 100,000 gallons of fuel oil, or enough for an 8-10 day supply for Plant operation at limited output. In the opinion of the Engineers, such storage capacity would not be adequate for continuous operation on fuel oil. In operation of the Plant, the University has experienced no interruptions in supply of natural gas. However, because of the current national energy crisis, possible shortages of energy supplies and the nature and effect of present or future governmental regulation, no assurance can be given that fuel supplies will be available in quantities needed by the Plant.

#### ENGINEERING REPORT

Carnahan-Thompson-Delano, Inc., (the "Engineers"), have prepared an engineering report on the Plant, a copy of which is attached as Exhibit C.

#### UTILITY SERVICE AGREEMENTS

Utility Service Agreements have been entered into with each of the other customers of the heating and cooling system, providing that rates shall be adjusted monthly if necessary to assure that the revenues are at least adequate to provide for the payment of debt service, operation and maintenance costs, and deposits to the funds and reserves as provided in the Bond Resolution and to meet the other requirements of the Bond Resolution. These customers include the State of Oklahoma Department of Health, the State of Oklahoma Department of Institutions, Social and Rehabilitative Services, the Oklahoma Medical Research Foundation, University Hospital, Presbyterian Hospital, Presbyterian Doctors Office Building and McGee Eye Institute. The University as a primary user of services of the Plant has covenanted in the Bond Resolution to maintain such rates and charges which when added to the revenues derived from other customers will be at all times sufficient for the purposes required by the Bond Resolution.

Each customer under contract agrees to not purchase heating and cooling services for its buildings at the Center from any other sources, and to not build a heating and cooling system to provide services to its buildings at the Center, as long as their Utility Service Agreement is in effect, except for such services that are beyond the capacity of the Plant.

The Board of Regents covenants and agrees not to terminate service to a customer except for non-payment of charges or other breaches of the Utility Service Agreement which the Board of Regents deems are material. Notwithstanding such covenant, the University retains the right, upon three years written notice, to demand and receive all or part of the services of the Plant sold or disposed of to other parties.

The Utility Service Agreement provides for semi-annual apportionment and determination of the "Cost-of-Service" rates on the basis of the amounts, types and conditions of service, and monthly "Base Rate Adjustments" are to be made to provide for increases or decreases in costs or for any other contingencies. All customers agree to pay their respective rates and charges from any legally available revenues (which include budgeted and unrestricted or undesignated revenues). The Oklahoma

Medical Research Foundation's obligation to pay is not subject to such restriction. The loss of any customer will require the Board of Regents to raise the "Cost-of-Service" rates for the remaining customers in order to reapportion the factors for debt service and reserves, plus any non-variable operating costs. The Utility Service Agreements with these remaining customers contain a provision that their rates may not be increased by more than 100% over the previous year as a result of the loss of any customer(s) which have purchased 50% or more of the services.

The Utility Service Agreements contain provisions governing the manner in which heating and cooling service shall be provided and received and factors that govern the billing procedures. The Utility Service Agreements may not be amended without the consent of the Bank.

In summary, various entities located at the Center have agreed to utilize the services of the Plant including the State of Oklahoma Department of Health, the State of Oklahoma Department of Institutions, Social and Rehabilitative Services, the Oklahoma Medical Research Foundation, University Hospital, Presbyterian Hospital, Presbyterian Doctors Office Building and McGee Eye Institute, all in addition to the services required by the University of Oklahoma buildings. However, the Veterans Administration Hospital, located at the Center, does not use the services of the Plant.

A copy of the form of a Utility Service Agreement is attached as Exhibit D. All of the other Agreements follow this same format.

#### CONTROL SERVICE AGREEMENTS

The initial project included the installation in the Plant of a Johnson T-6500 computerized central control panel and cable in the tunnels extending to the initial group of buildings being served. The facility began its initial operation in June of 1973 and is of great benefit in improving the quality of operation in the University buildings and in reducing maintenance and operating costs for the University in operating the heating and cooling systems throughout the Center. It will record and control in specific buildings and areas temperature, humidity, security, report malfunctions, measure quantity of service, and such other things, all from one central point.

A copy of the form of a Control Service Agreement is attached as Exhibit E. All of the other Agreements follow this same format.

#### CUSTOMERS OF THE PLANT

The University of Oklahoma - The University of Oklahoma Health Sciences Center, (the "Health Sciences Center"), located at the Oklahoma Health Center, is a part of the University and is governed by the University's Board of Regents, but under Oklahoma law it also is a constituent of The Oklahoma State System of Higher Education separate from the University's main campus at Norman, Oklahoma. As such, it receives a separate budgetary apportionment from the State Regents for Higher Education, which under the Oklahoma Constitution apportions the Legislature's consolidated appropriation for higher education.

Since 1929, all of the University's medical departments, hospitals, outpatient clinics and medical libraries have been consolidated at the Health Sciences Center, which now includes the College of Medicine, College of Nursing, College of Dentistry, College of Pharmacy, College of Health and the Graduate College. Principal facilities include five major academic buildings, such as Basic Science Education, College of Medicine, College of Nursing, Dental Clinical Sciences and Bio-Medical Sciences, a medical research building, a service center and various smaller structures.

Oklahoma Medical Research Foundation - The Oklahoma Medical Research Foundation's facilities, located in the Center, utilize the services of the Plant. The Foundation is a non profit corporation employing approximately 350 persons. Research activities are primarily in heart disease, cancer and blood disorders. Outpatient clinic facilities have recently been expanded following the relocation of the Foundation's 20 inpatient bed facilities to the Presbyterian Hospital. The Foundation also has a two story addition to its facilities under construction which will use the services of the Plant.

University Hospital - University Hospital which has utilized the services of the Plant since it commenced operation was transferred from the Board of Regents to the Board of Trustees of the University Hospital in 1973. The 317 bed University Hospital continues to utilize the services of the Plant.

The State of Oklahoma Department of Health - The State of Oklahoma Department of Health is responsible for the administration of various health programs, both preventive and regulatory, of the State of Oklahoma and, to some extent, of the Federal Government. Its functions include such diverse tasks as testing toxicity of household products, hospital planning and development, testing milk and water quality, statistical vital record services, and child and mental health services. Its 160,000 square foot, \$4,500,000 building contains nine stories of offices and three floors of laboratories and brings together the Department's main facilities, which for several years have been located in a number of scattered buildings in the Oklahoma City area. The Department is a part of the State Government and also derives a substantial part of its budget from the Federal Government.

Presbyterian Group - Presbyterian Hospital also utilizes the services of the Plant. The Hospital contains 303 beds. Other members of the Presbyterian Group are the McGee Eye Institute and the Presbyterian Doctor's Office Building. A new facility for the Oklahoma City Clinic is under construction which would also utilize the services of the Plant.

Department of Institutions, Social and Rehabilitative - This Department is responsible for the operation of Oklahoma Childrens Memorial Hospital. This Hospital currently has 148 licensed beds. The Hospital includes an original portion, a new East Wing and a West Wing which has just been completed. Projected capacity of this Hospital is 400 beds. The Hospital utilizes the services of the Plant.

## FUTURE PHASES

With completion of the Plant building under Phase III, and equipment additions under Phase IV, future expansion will consist primarily of mechanical equipment, tunnel extensions, and service connections. The time intervals will depend upon the progress rate of expansion in the Center and other factors. Future expansion, if undertaken, may be financed with revenue bonds that would be equally secured with the Series 1973 Bonds and the Bonds.

## SUMMARY OF CERTAIN PROVISIONS OF THE BOND RESOLUTION

The following is a summary of certain provisions of the Utility System Revenue Bonds, Series 1973 Bond Resolution by the University, dated as of July 1, 1973, as supplemented by the 1977 Supplemental Bond Resolution dated as of July 1, 1977. Reference is made to the Bond Resolution for a complete recital of its terms and provisions.

### BOND PROCEEDS

The 1977 Supplemental Bond Resolution provides that the proceeds of the Bonds, excluding accrued interest, if any, shall be deposited with the Treasurer of the State of Oklahoma to the credit of a special account entitled the "University of Oklahoma Utility System Revenue Refunding Bonds, Series 1977 Bond Proceeds Fund", (the "Bond Proceeds Fund"). Monies contained in the Bond Proceeds Fund shall be drawn upon, with proper authorization, for the following purposes:

- A. To pay the professional and miscellaneous expenses incidental and necessary to the issuance of the Bonds; and
- B. To transfer the remaining proceeds of the Bonds to the Refunding Escrow Account created pursuant to the Escrow Agreement to be applied toward the purchase of the Government Securities.

Accrued interest shall be paid to the Bank at the time the Bond proceeds are received. The Bank shall deposit such accrued interest in the Interest Account of the University of Oklahoma Utility System Revenue Bonds, Series 1973, Bond Fund, (the "Bond Fund").

### USE OF FUNDS

The Funds and Accounts, with the exception of the Bond Proceeds Fund, have been established pursuant to the Series 1973 Bond Resolution. All amounts required to be set aside or accrued for the payment of the Series 1977 Bonds, with the exception of the Bond Proceeds Fund, shall be deposited in the Funds and Accounts previously established for the Series 1973 Bonds and commingled therein as follows:

- A. The Bond Proceeds Fund shall be used to receive the proceeds of the Bonds, excluding accrued interest; and to complete the purchase of the Government Securities. The Bond Proceeds Fund shall be maintained with the Treasurer of the State of Oklahoma.

- B. The University of Oklahoma Utility System Revenue Bonds, Revenue Fund, (the "Revenue Fund"), shall be used to receive the proceeds of the monthly Utility Service Agreements and Control Service Agreements. The Revenue Fund shall be maintained as a trust fund with the Treasurer of the State of Oklahoma.
- C. The Bond Fund and its corresponding Interest Account, Principal Account, and Reserve Account shall be used for the following purposes:
- (1) The Interest Account shall be used to receive transfers from the Revenue Fund, the Bond Fund Reserve Account, and the Special Reserve Fund in amounts sufficient to pay, when due and payable, the interest on the Bonds.
  - (2) The Principal Account shall be used to receive transfers from the Revenue Fund, the Bond Fund Reserve Account and the Special Reserve Fund in amounts sufficient to pay, when due and payable, the principal of the Bonds and, if funds are available for such purpose, to effect the purchase or redemption of the Bonds prior to stated maturity.
  - (3) The Bond Fund Reserve Account established by the Series 1973 Bond Resolution and enlarged by the Series 1975 Bonds Supplemental Bond Resolution shall maintain a minimum balance equal to the maximum annual Debt Service Requirement on the Series 1973 Bonds and the Bonds and shall be used to prevent any default in paying the principal of and interest on any of the Bonds, and to pay the last remaining outstanding Bonds and interest thereon. Amounts in excess of the minimum balance required may, at the discretion of the Board of Regents, be transferred to the Principal Account of the Bond Fund to effect the purchase or redemption of Bonds prior to stated maturity.

The Bond Fund and related Accounts and Reserve shall be maintained with the Bank.

- D. The University of Oklahoma Utility System Revenue Bonds, Series 1973 Repair and Replacement Fund, (the "Repair and Replacement Fund"), is required to maintain a minimum balance in the amount of \$200,000 to pay the expense of repairs and replacements for the Plant. This Fund will be expended only upon recommendation of the Consulting Engineer and approval of the Board of Regents. If a portion or if all of this Fund is expended, it will be replenished by transfers from the Revenue Fund, or any other available source of funds, within a period of twenty-four months of the creation of such deficiency. The Repair and Replacement Fund shall be maintained with the Treasurer of the State of Oklahoma.
- E. The University of Oklahoma Utility System Revenue Bonds, Series 1973, Special Reserve Fund, (the "Special Reserve Fund"), shall be used to receive surplus monies contained in the Revenue Fund and all other Accounts and Funds. Upon proper authorization of an official of the

University designated by the Board of Regents, the Special Reserve Fund may be used as follows:

- (1) To pay the principal and/or interest requirements on any of the Bonds due and payable on the next ensuing January 1 or July 1, in whole or in part, through transfers to the Principal Account and/or Interest Account of the Bond Fund;
- (2) To purchase Bonds on the open market through transfers to the Principal Account of the Bond Fund;
- (3) To redeem Bonds prior to stated maturity through transfers to the Principal Account of the Bond Fund;
- (4) Upon issuance of additional bonds, if it is desired to expand the Plant at a later date, to adjust the minimum balance required in the Bond Fund Reserve Account and the Repair and Replacement Fund as a result of the issuance of such additional bonds;
- (5) To pay the costs of improving the Plant; or
- (6) To be used for any lawful purpose of the University.

The Special Reserve Fund shall be maintained with the Bank.

#### PURCHASE OF BONDS ON THE OPEN MARKET

Whenever, after completion of the Plant, there is in the Bond Fund a surplus in excess of the amount of interest and principal becoming due within the next twelve months, and the Bond Fund Reserve Account and the Repair and Replacement Fund are fully replenished if any payments have been made therefrom, such excess may be used by the Board of Regents to retire Bonds prior to maturity, through the purchase thereof on the open market at a price not in excess of the next applicable call price of any redeemable Bonds, exclusive of accrued interest.

#### FLOW OF FUNDS

As the funds coming in from the monthly Utility Service Agreements and Control Service Agreements are collected, the Board of Regents shall cause these funds to be deposited as soon as possible in the Revenue Fund in the possession of the Treasurer of the State of Oklahoma.

- A. On or before the tenth (10th) day following the close of the calendar month in which such monies shall have been received, the Board of Regents shall make transfers from the Revenue Fund as follows:

- (1) To the Bond Fund an amount equal to one-twelfth of the annual principal and one-sixth of the semi-annual interest requirements on the Bonds; and
  - (2) To the Site Support Service Unit Fund in the possession of the Treasurer of the State of Oklahoma, one-twelfth of the estimated annual operating and maintenance expense of the Plant.
- B. If the monies contained in the Bond Fund on or before each June 15 or December 15 are not sufficient to make the required payments, the Trustee Bank shall utilize monies contained in the following Reserves, in the following order, to complete such transfers:
- (1) The Special Reserve Fund
  - (2) The Repair and Replacement Fund
  - (3) The Bond Fund Reserve Account
- C. If the Bond Fund Reserve Account or the Repair and Replacement Fund have been depleted through withdrawals, the Board of Regents shall cause the amount remaining in the Revenue Fund, after the required transfers to the Principal and Interest Accounts of the Bond Fund and transfers to Site Support Service Unit Fund on or before each June 15 or December 15, to be transferred to the Bond Fund Reserve Account and the Repair and Replacement Fund, so that the required minimum balance of those Funds are re-established within no more than twenty-four months of the date of the original depletion.
- D. After the required transfers have been made to the Bond Fund and the Site Support Service Unit Fund from the Revenue Fund, including transfers to the Bond Fund Reserve Account and the Repair and Replacement Fund, the Board of Regents may, at the time such required transfers are made, transfer any monies remaining in the Revenue Fund to the Special Reserve Fund.

#### ADDITIONAL BONDS

After the issuance, sale and delivery of the Bonds, and for so long as any Bonds remain outstanding, the Board of Regents shall not issue any additional parity bonds, except as hereinafter set forth. The Board of Regents may issue additional bonds payable from the revenues derived from the Trust Estate pari passu with the Bonds provided:

- A. The Board of Regents are not in default in meeting any of the agreements, covenants and obligations to be performed by the Board of Regents under the Bond Resolution;
- B. The bonds to be issued are required to provide satisfactory service to the contracting institutions receiving heating and/or cooling service and/or computer control service prior to the issuance of additional bonds, or if

additional Utility Service Agreements or Control Service Agreements are signed or the existing Utility Service Agreements or Control Service Agreements are amended to allow for the issuance of said bonds, to provide for additional contracting institutions;

- C. A Certified Public or Municipal Accountant shall certify to the Trustee Bank with the approval of the Board of Regents, that the net revenues derived from the heating and cooling system owned and operated by the Board of Regents for the fiscal year next preceding the fiscal year in which such additional bonds are issued shall have been at least equal to the annual amount required to be paid or accrued into the Bond Fund for the payment of debt service requirements on all bonds then outstanding. In addition, a Consulting Engineer shall certify to the Trustee Bank, with the approval of the Board of Regents, that the estimated net revenues to be derived from the then existing heating and cooling system and the additional heating and cooling facilities to be constructed, shall, in the fiscal year following the date of the initial use of such additional heating and cooling facilities, be at least equal to the annual amount required for the payment of debt service requirements on all Bonds then outstanding and the additional bonds to be issued. The term "net revenues" shall mean the gross revenues derived from the operation of the heating and cooling system by the Board of Regents minus the deduction of operation and maintenance expenses; and
- D. The existing Utility Service Agreements and Control Service Agreements are amended to reflect the additional bonds.

Nothing herein contained shall be construed as preventing the Board of Regents from issuing refunding bonds, nor as preventing the Board of Regents from issuing obligations payable from and constituting a lien or charge on the revenues junior and inferior to the Bonds.

In the event additional bonds are issued, the supplemental bond resolution authorizing such additional bonds shall, among other things, provide that all amounts derived from the operation of the additional facilities shall be deposited in the Revenue Fund. In addition, there shall be deposited in the Bond Fund Reserve Account, in full at the time of delivery of such additional bonds, the amount required to provide a minimum balance in that reserve equal to the maximum annual debt service requirement on the Bonds and additional bonds to be outstanding. An amount recommended by the Consulting Engineer for the additional bonds issued shall, at the time of the delivery of the additional bonds, be deposited in the Repair and Replacement Fund.

#### ARBITRAGE

Notwithstanding all the provisions hereof, monies in the various funds, accounts and reserves created in the Bond Resolution shall not be allowed to accumulate or be invested in a manner which would result in the loss of exemption from Federal Income Taxation of interest on the Bonds or in such a manner which would result in



the Bonds constituting taxable "arbitrage bonds" within the meaning of Section 103(c) of the Code.

## INVESTMENTS

Monies contained in the Revenue Fund and the Repair and Replacement Fund shall be continuously invested and reinvested by the Treasurer of the State of Oklahoma in direct obligations of the United States of America or in obligations the principal and interest of which are unconditionally guaranteed by the United States of America that shall mature not later than the respective dates, as estimated when the monies in those Funds shall be required for the purposes intended.

Monies contained in the Principal Account, the Interest Account, the Bond Fund Reserve Account and the Special Reserve Fund shall be continuously invested and reinvested by the Bank in securities that shall mature in a manner consistent with the use of the monies contained in such Account, Reserve or Fund but within no more than five years. These monies may be invested in direct general obligations or in obligations the principal of and interest on which are unconditionally guaranteed by the United States of America; bonds, debentures or notes issued by any of the following agencies: Bank for Cooperatives, Federal Land Banks or Federal National Mortgage Association, including Participation Certificates; Public Housing Bonds, Temporary Notes or Preliminary Loan Notes, fully secured by contracts with the United States of America; full faith and credit, direct and general obligations of any State, or unlimited tax direct and general obligations of any political subdivision thereof, to the payment of which the full faith and credit of such political subdivision is pledged, provided at the time of purchase such obligations are rated in either of the three highest rating categories by one nationally recognized bond rating service and are legal investments for fiduciaries in New York and Oklahoma; and bank savings accounts, or time certificates of deposit or certificates of deposit, provided that such accounts or certificates are collaterally secured by securities which themselves are previously described as being eligible and have a market value at least equal to the amount held in such bank savings account or held under such certificates of deposit and are issued by a bank having a capital and surplus of not less than \$15,000,000.

Interest earned on the investment of the Principal Account, the Interest Account and the Bond Fund Reserve Account of the Bond Fund; and the Special Reserve Fund shall be deposited in the Account, Reserve or Fund from which it was derived. When not required to meet requirements as set out in the Bond Resolution, the investment income and other monies contained in the Bond Fund Reserve Account in excess of the minimum balance required in that Reserve Account, may at the discretion of the Board of Regents, be transferred to the Principal Account of the Bond Fund to be used to purchase or redeem Bonds prior to stated maturity.

The Revenue Fund and the Repair and Replacement Fund shall be maintained with the Treasurer of the State of Oklahoma and investment income derived from those Funds when not required to meet requirements as set out in the Bond Resolution shall not be deposited in those Funds, but shall be forwarded to the Bank to be deposited in the Special Reserve Fund.

## DEPOSITORY OF FUNDS AND SECURITY FOR DEPOSITS

The Revenue Fund and the Repair and Replacement Fund shall be maintained by the Treasurer of the State of Oklahoma. The Bond Fund, including the Interest Account, the Principal Account, the Bond Fund Reserve Account and the Special Reserve Fund shall be maintained with the Bank as special trust accounts for the benefit of the holders of the Bonds and shall not be subject to lien or attachment by any creditors of the Board of Regents. The money in those Funds shall be continuously secured as are deposits of the State of Oklahoma or in the manner prescribed by Federal Law for securing trust funds, which qualified securities shall have a market value of not less than the total amounts on deposit in the Funds.

The Bank shall, in due season prior to the dates on which principal and interest fall due, make proper arrangements with any bank or agency which is serving as additional paying agent of the Bonds, pursuant to which all Bonds and coupons shall be promptly paid upon presentation at either place of payment.

### PARTICULAR COVENANTS

The Board of Regents covenants and agrees in the Bond Resolution as follows:

- A. The Board of Regents shall punctually pay all interest and principal requirements on the Bonds and will faithfully observe and perform all agreements, covenants and obligations to be performed under the Bond Resolution.
- B. The Board of Regents shall not create any pledge, lien, charge or other encumbrance upon the pledged income, other than the lien and pledge created by the Bond Resolution and any supplemental bond resolution which would authorize and secure additional bonds.
- C. The Board of Regents will pay or cause to be paid any governmental charges lawfully imposed upon the trust estate and will keep the trust estate free from all judgments, mechanics and material liens and all other encumbrances.
- D. The Board of Regents shall proceed with all reasonable dispatch to complete the Plant; shall at all times operate or cause to be operated the heating and cooling system in an efficient manner and at a reasonable cost; shall keep the facilities in good repair, working order, and condition; and shall make all necessary repairs, renewals, replacements, additions, extensions and betterments thereto, so that at all times the business of the Board of Regents shall be properly and advantageously conducted.
- E. The Board of Regents agrees that the heating and cooling service and computerized control system service produced by the Board of Regents shall be disposed of solely for the benefit of the Board of Regents and that the revenues derived from the operation and ownership of the facilities shall be sufficient to meet all requirements of the Bond Resolution and shall be disposed of in the manner specified therein.

- F. The Board of Regents shall fix, maintain, and collect rates and charges for all services furnished and supplied by the Board of Regents, which shall be adequate to provide sufficient revenues for all purposes required by the Bond Resolution; and shall not furnish or supply any service or commodity free of charge to any person, firm or corporation, public or private; and shall promptly enforce the payment of any and all accounts owed to the Board of Regents by reason of its ownership and operation of the facilities by discontinuing service and/or filing suit therefor within sixty days after any such accounts are due.
- G. The Board of Regents may sell, lease, or otherwise dispose of all or substantially all of the facilities, provided that simultaneously therewith, provision is made for the redemption of all of the Bonds then outstanding; and the Board of Regents may dispose of any portion of the facilities or properties thereof, which have been declared by the Board of Regents and certified by the Consulting Engineer as being unserviceable, inadequate, obsolete, or unfit to be used, or no longer required for the operation of the Board of Regents' business.
- H. The Board of Regents shall keep the facilities insured to the extent available, at reasonable cost with responsible insurers with policies payable to the Board of Regents and the Bank as their respective interests may appear against risks of direct physical loss, damage, or destruction of the properties, at least to the extent that similar insurance is usually carried by private corporations operating like properties, and shall at all times keep the facilities insured against loss of use and occupancy from any of the aforesaid hazards, in such an amount as shall provide for not less than 400 days after a 100-day exclusionary period, a coverage equal to the net earnings which are prevented by such loss, plus such fixed charges and expenses as must necessarily continue during the period of such loss, to the extent that such fixed charges and expenses would have been earned had not such loss occurred.
- I. The Board of Regents shall keep proper books of account and within ninety days after the close of each fiscal year of the Board of Regents, it shall cause its accounts to be audited by independent Certified Public or Municipal Accountants and a copy of such audit shall be filed promptly with the Bank and sent to any holder of the Bonds who requests the same in writing.
- J. The Board of Regents shall retain a firm of independent engineers on a continuous basis for the purpose of providing the University with engineering counsel in the operation of the facilities as requested. In addition to other prescribed duties, the Consulting Engineers shall, not later than 120 days after the closing of each fiscal year make a physical inspection of the facilities and prepare a report based upon such examination and a survey of the management of the business of the facilities and the operation and maintenance of its properties and state if the Board of Regents has complied with the Bond Resolution; a copy of such report shall be

filed with the Bank and a copy shall be mailed to any Bondholder requesting same in writing.

- K. The Board of Regents shall not expend any of the income, revenues, receipts, profits, and other monies of the facilities for any extensions, betterments, and improvements thereto which are not economically sound or which shall not properly and advantageously contribute to the conduct of the business in an efficient and economical manner.
- L. The Board of Regents will not consent to the rescission, alteration, amendment or modification of the Utility Service Agreements and the Control Service Agreements except: (i) with the written consent of the Bank, which consent may be given only if, in the opinion of the Bank, such action would not impair the effectiveness of the document as part of the security for the payment of the Bonds or reduce the income or increase the expenses of the Board of Regents, and would not materially adversely affect the rights of the holders of the Bonds; (ii) as may be necessary in connection with the issuance of additional bonds; or (iii) with the written consent of the holders of two-thirds in aggregate principal amount of the Bonds then outstanding.
- M. The Board of Regents will not consent to the assignment or transfer of the Utility Service Agreements or the Control Service Agreements without consent of the Bank.
- N. The Board of Regents will vest in the Bank or the holder or holders of the Bonds of a specified percentage the right to enter into possession of the Plant and to operate it until a default is remedied or until all bonded indebtedness related to the Plant is retired, whichever shall first occur.

#### CONCERNING THE TRUSTEE BANK

The exculpatory clauses will be limited to the following:

- A. The Bank shall be entitled to rely upon the advice of attorneys, professional architects, and accountants, and any act or omission to act done or omitted by the Bank in reliance upon such advice and counsel shall not constitute negligence.
- B. The Bank shall not be required to take notice or be deemed to have notice of any state of default hereunder unless such notice be given in writing by a Bondholder.
- C. The Bank may execute any trusts or powers hereunder and perform any duties hereunder through employees, attorneys, agents or servants, and it shall be entitled to advice of counsel in regard thereto, and may receive or recover any reasonable costs or expenses in connection therewith.
- D. The Bank shall not be responsible for doing or performing any thing or act which the Board of Regents shall have covenanted to do or perform, or

for any other compliance with any covenant by the Board of Regents , or for the sufficiency of the security for the Bonds issued , or otherwise as to maintenance of such security; nor shall the Bank be bound to ascertain or inquire as to the performance of any covenant , condition or agreement by the Board of Regents , but it may require full information and advice in regard to any of the foregoing .

- E. The Bank shall not be accountable for the use of any Bonds authenticated or delivered , or for any of the proceeds of such Bonds after the same shall have been paid out by it; and the holders of the Bonds shall not be entitled to any interest from the Bank on funds in its hands for payment of the same .
- F. The Bank shall not be accountable for acting upon any notice , requisition , request , consent , certificate , order , affidavit or other information believed by it to be genuine and correct and to have been signed or sent by the person or persons proper to have done so .
- G. The Bank shall not be bound to recognize any person or persons as a Bondholder or Bondholders or to take action at his or their request , unless such Bond or Bonds be deposited with the Bank or submitted to it for inspection; and any action taken by the Bank pursuant to the Bond Resolution upon request or authority of the Bondholders shall be conclusive and binding upon all future owners of the same Bond or any Bonds issued in exchange therefor or in place thereof .

#### MISCELLANEOUS

If at any future date , it is determined by the Attorney General of the State of Oklahoma that under existing statutes any funds or accounts created by the Bond Resolution should appropriately be maintained by the Treasurer of the State of Oklahoma , then such funds or accounts shall be transferred from the Trustee Bank accordingly .

#### THE 1977 SUPPLEMENTAL BOND RESOLUTION

The Bonds are issued under the terms of a 1977 Supplemental Bond Resolution which has provisions for the disposition of bond proceeds and for due dates , interest rates , call premium and other provisions that pertain only to the terms of the Bonds . The maturities , interest rates , call premium and other provisions are described in this Official Statement . Reference is made to the 1977 Supplemental Bond Resolution for a complete recital of its terms and provisions .

## THE UNIVERSITY OF OKLAHOMA

### GENERAL

At the first meeting of the territorial legislature of Oklahoma on December 19, 1890, legislation was enacted which called for the building of three institutions of higher education, a normal school at Edmond, an agricultural and mechanical school at Stillwater and a university at Norman. This legislation marked the beginning of the University of Oklahoma. In 1892 the University opened its doors in a rented building with 119 students and four faculty members. The University has since grown to include the Norman campus of approximately 1,000 acres, on which are located 230 buildings valued at more than \$100,000,000; and the Health Sciences Center of the University located in Oklahoma City which is in the process of development and expansion into a multi-million dollar, 200 acre Oklahoma Health Center with the University complex as its nucleus. The University academic structure consists of sixteen colleges. Colleges located on the Norman campus include the University College, the College of Arts & Sciences, the College of Business Administration, the College of Education, the College of Engineering, the College of Environmental Design, the College of Fine Arts, the College of Liberal Studies, the College of Law, and the Graduate College. Colleges located at the Health Sciences Center campus in Oklahoma City include the College of Dentistry, College of Health, College of Medicine, College of Nursing, College of Pharmacy and the Graduate College.

The University is an accredited member of the North Central Association of Colleges and Secondary Schools. In addition, the University and its colleges, schools and departments also hold memberships in more than 60 organizations and accrediting agencies.

The University grants the bachelor's degree of arts or science in some 150 major fields of study. In addition, a broad range of graduate degrees are available, with masters and doctoral degrees being offered in 143 and 72 areas respectively. During the 1975-76 academic year, the University granted degrees as shown in the Table below. In addition, it should be pointed out that the University recently passed an important milestone in the awarding of its one hundred thousandth degree at the 1974 spring commencement.

#### 1975-76 Academic Year

<u>Degree</u>	<u>Norman Campus</u>	<u>Health Sciences Center</u>	<u>Total</u>
Bachelor	2,380	239	2,619
Master	1,102	113	1,215
Doctorate	152	44	196
J. D.	180	--	180
D. D. S.	--	25	25
M. D.	--	139	139

## THE HEALTH SCIENCES CENTER

The University of Oklahoma Medical Center originated with the establishment of University Hospital in 1918. Ten years later, in 1928, the present College of Medicine building was built, making it possible to transfer the pre-clinical program from the Norman campus and centralize all the college's operations. Since 1929, all of the University's medical departments, hospitals, outpatient clinics, and medical libraries have been consolidated at the University of Oklahoma Health Sciences Center. The Health Sciences Center of the University, together with the several public and non-public units concerned with health care, comprise the Oklahoma Health Center. In addition to the Health Sciences Center, which forms the nucleus of the Oklahoma Health Center, is the Presbyterian Hospital Complex, University Hospital, the State of Oklahoma Department of Health and the Department of Institutions, Social and Rehabilitative Service (the Oklahoma Children's Memorial Hospital), Veterans Administration Hospital, the Oklahoma Medical Research Foundation and others. The Oklahoma Health Center is located on a 200 acre tract in Oklahoma City and is the central health, education and health care unit in the State.

The Health Sciences Center of the University now includes the College of Medicine, College of Nursing, College of Dentistry, College of Health, Graduate College and the College of Pharmacy. Principal facilities include five major academic buildings, a medical research building, and various smaller structures. A major building is under construction for the Library and Learning Resources Center Building.

In 1973, the Oklahoma Legislature provided for the creation of a Board of Trustees to operate and govern University Hospital and Everett Tower. The Legislature also provided for the transfer of the Oklahoma Children's Memorial Hospital to the Department of Institutions, Social and Rehabilitative Services. These two hospitals provide patient care and clinical teaching facilities.

As stated previously, the main campus of the University is located in Norman, approximately 20 miles south of Oklahoma City, and the Health Sciences Center of the University is located in the area of 800 N. E. 13th Street, near the State Capitol in Oklahoma City.

## ENROLLMENT

Total enrollment for the Fall semester of 1976 at the University totalled 25,329 students, of which 20,010 were in residence on the main campus in Norman, 2,553 were enrolled at the Oklahoma Center for Continuing Education located on the Norman campus, and 2,766 were at the Health Sciences Center in Oklahoma City. Total University enrollment for Spring of 1977 was 24,939 students, of which 18,503 were in residence on the main campus in Norman, 3,776 were enrolled at the Oklahoma Center for Continuing Education located on the Norman campus, and 2,660 were at the

Health Sciences Center in Oklahoma City. The vast majority of students are from Oklahoma, with every county in the state being represented. However, the University also draws students from all 50 states of the Union and from many foreign countries.

A study of enrollment figures over the past 30 years indicates that the University has experienced a stable and substantial growth. The enrollment trends from the Fall of 1945 to the Fall of 1976 are revealed by the following figures for the Norman campus, the total shown being the actual count of all students enrolled for the Fall semester of the academic year.

<u>Year</u>	<u>Enrollment</u>	<u>Year</u>	<u>Enrollment</u>
1945	3,323	1971	18,441
1950	9,195	1972	19,494
1955	9,849	1973	19,647
1960	10,316	1974	19,924
1965	15,640	1975	21,316
1970	18,052	1976	20,010 <u>1/</u>

The actual count of students located at the Health Sciences Center over the past seven years is shown in the following figures.

<u>Year</u>	<u>Enrollment</u>
1970	1,016
1971	1,236
1972	1,503
1973	1,600
1974	2,034
1975	2,257
1976	2,766 <u>1/</u>

1/ College of Pharmacy enrollment (about 405 students) became part of Health Sciences Center rather than Norman Campus.

#### UNIVERSITY LIBRARIES

Resources of the University Libraries are the largest in the state, numbering over 1,400,000 volumes plus several hundred thousand pieces of other graphic records. The bulk of these materials, constituting the general library are housed in the William Bennett Bizzell Memorial Library. The University also maintains 12 branch libraries. These include libraries serving the Health Sciences Center, the Colleges of Engineering, Fine Arts, Law, and Pharmacy; those for the Schools of Architecture, Geology, and Journalism; and those serving the departments of Chemistry, Physics and the University School. Construction bids were taken in late December 1975 for a Library and Learning Resources Center on the Health Sciences Center campus and this building is under construction. The proposed four story building will provide library capacity of over 230,000 books with seating capacity of 600.



Included within the resources of the University Libraries are several special collections such as the renowned DeGolyer Collection in the History of Science and Technology which is comprised of an assembly of rare editions and source books of approximately 40,000 volumes; the Frank Phillips Collection of Indian, Oklahoma and Western History numbering nearly 30,000 volumes; the Harry W. Bass Collection in Business History; and the William Bennett Bizzell Bible Collection.

#### HEALTH SCIENCES CENTER FACILITIES

The \$4,000,000 Basic Sciences Education Building, opened in 1970, was designed for each student to have a "home base" for laboratory work and study. Teaching space is provided for undergraduate, graduate and continuing dental and medical education, as well as training of physicians' assistants, radiological technicians, physical therapists, respiratory therapists and medical and nuclear medicine technicians. This building will be connected by a pedestrian walkway to the Bio-Medical Sciences Building.

Construction on the \$10,500,000 Dental Clinical Sciences Building began in 1974 and was completed in late 1975. The five story building is located at 1001 N. E. 11. The 113,000 square foot structure provides for teaching, research and office space, including 262 dental operatories, a general anesthesia suite, four teaching laboratories, and five small clinic laboratories.

Adjacent to the Dental Clinical Sciences Building is the \$8,700,000 ten story Bio-Medical Sciences Building. This structure houses research laboratories, animal holding facilities, and research space and offices for the faculty of the Colleges of Medicine and Dentistry.

In 1974, the Health Sciences Center of the University received notice that a construction-grant application for almost \$3,000,000 in federal funds had been approved for development of a Library and Learning Resources Center on the Oklahoma City campus. The federal grant, plus matching funds from private donations and some of the proceeds of a state bond issue, will provide a total of \$5,800,000 for the facility. The proposed library/learning center has been in the planning stages for almost eight years, pending funding, and has been described as one of the Health Sciences Center's critical educational needs. The four story structure will contain 92,904 net square feet. The facility will allow the library and learning center to develop innovative educational services for faculty and students. Library capacity will increase from 95,000 to 230,000 volumes, and the seating capacity from 125 to 600. Learning Resources Center personnel will have centralized building and laboratory facilities to produce films, audio and video tapes, and color slides for academic programs. Construction bids for this project were taken in late December 1975 and it is under construction.

Construction began on the new Nursing Building for the College of Nursing in December 1975, and was completed in January, 1977. The new nursing facility consists of a large one story building with lecture halls, audiovisual facilities, a nursing library and practice area with ten-bed teaching capacity. This large one story building will be adjoined to a four story building with additional two story capacity.

This four story building will contain seminar rooms and additional teaching room capacity. Cost of the College of Nursing facility exceeded \$4,000,000.

The initial Phase I of the Steam and Chilled Water Plant at the Oklahoma Health Center was funded through bonds issued through the Oklahoma University Development Authority in 1970. This resulted in the development of the entire plant site and construction of related facilities. The Steam and Chilled Water Plant was purchased from the Oklahoma University Development Authority from a portion of the proceeds of the \$10,125,000 University of Oklahoma Board of Regents Utility System Revenue Bonds, Series 1973. The remaining portion of the Series 1973 Bonds funded Phase II additions to the Plant which provided steam and chilled water and a computerized control system to Presbyterian Hospital and other major buildings. In early 1975, the University of Oklahoma Board of Regents issued \$6,500,000 in Utility System Revenue Bonds, Series 1975, to finance Phase III & IV additions to the Steam and Chilled Water Plant at the Oklahoma Health Center. This additional capacity served two new buildings constructed by the Department of Institutions, Social and Rehabilitative Services. The Bio-Medical Sciences Building, the Dental Clinical Sciences Building and the College of Nursing Building were linked to the system. Additional capacity was also provided by Phase IV construction. The underground system of tunnels utilized by this system will also be used to provide underground walkways interconnecting the various buildings within the Steam and Chilled Water Plant System.

#### ADDITIONAL UNIVERSITY FACILITIES

- A. Norman Campus. A recent major addition to the Norman campus of the University is the Lloyd Noble Arena which was completed during the Summer of 1975 at a total cost of approximately \$5,800,000. The Arena, which serves as a multi-purpose facility for a variety of special events and also houses varsity athletic programs in basketball, wrestling and gymnastics, has a total seating capacity of 13,000 seats.

In the Spring of 1976, a new Law Center was completed which greatly expanded the classroom and library facilities of the College of Law. In addition, the Law Center has been designated as, and provides space for, the Western Regional Office of the American Academy of Judicial Education and the South Central Regional Office of the National Center for the State Courts.

The Charles B. Goddard Health Center was completed in 1971 at a cost in excess of \$1,800,000. This modern facility contains an outpatient clinic; two emergency rooms; a 54-bed hospital fully approved by the Joint Commission on Accreditation of Hospitals; and complete x-ray, laboratory, pharmacy, physical therapy and dietary facilities.

Significant additions were made to the educational facilities of the University with the recent construction of the Fred Jones, Jr. Memorial Art Center and the Physical Sciences Center. The Art Center, completed in February 1971, at a cost of \$2,400,000, houses the Museum of Art, the

the School of Art, and the offices of the College of Fine Arts. The Physical Sciences Center, also completed in 1971 at a cost of nearly \$4,400,000 houses the Departments of Chemistry, Math, and Physics.

Athletic facilities were also recently improved by the completion of an approximately \$6,400,000 Stadium Expansion Program partially funded by revenue bonds. The major parts of this Program included the construction of a new press box and a 9,000 seat upper deck on the west side of the Oklahoma Memorial Stadium.

Through the Oklahoma Center for Continuing Education, the University offers part time studies at an education center originally financed primarily by a gift of \$2,000,000 received from the W. K. Kellogg Foundation. At the time this center was constructed, this was the largest grant ever made to an educational institution in Oklahoma. In 1977-76, there were approximately 1,802 programs offered to nearly 69,711 adults through the Center. In addition, 110 programs were provided at locations outside the United States. The instruction for the programs is provided by University of Oklahoma faculty.

- B. Other University Facilities. The University also has properties at the Naval Technical Training Center, known as South Base, and the Naval Air Station of World War II, known as North Base. Three major facilities are operated at North Base: the Max Westheimer Airfield which is the largest university owned airport in the nation and is operated by the University as a municipal airport for the City of Norman, Oklahoma, the Merrick Computer Center, and the Swearingen Research Park. The Computer Center is a major data facility providing research, administrative and informational services to the University and to other institutions of the State and the region. The Swearingen Research Park is a 900 acre tract established in 1957 to provide industry and government with the opportunity to establish research laboratories at a location where University resources, skilled manpower, equipment and libraries are easily accessible. In addition, two purely recreational facilities located in the Research Park are an Olympic-sized swimming pool and the University polo field.

Facilities at other sites include the Biological Research Station located on Lake Texoma at Willis, Oklahoma; the Fisheries Research Center at Noble, Oklahoma; the Earth Sciences Observatory near Tulsa; and an adult education center at the Hacienda El Cobano in Colima, Mexico.

#### PRESENTLY OUTSTANDING BONDS

The statement of the outstanding bonds of the University as of the month of March, 1977, is shown in Exhibit I. All bonds have been issued as revenue bonds. Most bonds have been issued for student housing projects or for student facilities.

As is shown in Exhibit I, as of the month of March, 1977, the University had outstanding bonds of \$48,231,000. Restricted funds totalled \$11,542,081, leaving outstanding bonds less total restricted funds equal to \$36,688,919 for the University.

## UNDERWRITING

The Bonds will be purchased from the University at a price of par plus accrued interest, if any, for reoffering by the Underwriters, \_\_\_\_\_. The Bond Purchase Contract provides that the Underwriters will purchase all the Bonds if any are purchased. The Underwriters reserve the right to join with securities dealers and other underwriters in offering the Bonds to the public and may offer and sell the Bonds to certain dealers and others at prices lower than the public offering price stated on page 5 hereof. The initial public offering price may be changed from time to time by the Underwriters.

## LEGAL OPINIONS AND TAX EXEMPTION

The unqualified approving opinion of Fagin, Brown, Bush, Selvidge & Tinney, Oklahoma City, Oklahoma, Bond Counsel, shall state that the interest earned on the Bonds is exempt from existing Federal and State of Oklahoma Income Taxes under existing statutes, regulations and court decisions. Bond Counsel will render a separate opinion that the Bonds are not "arbitrage bonds" as defined in Section 103(c) of the Code and regulations promulgated thereunder.

A transcript of the legal proceedings approved by the Attorney General of the State of Oklahoma, including a certificate that there is no litigation pending affecting the Bonds, and other closing papers shall be furnished to the Underwriters.

## NO LITIGATION

There is not currently any pending legal proceeding or legal proceedings against the University, which in the aggregate are material, nor is there any litigation against the University which would restrain or enjoin the issuance or delivery of the Bonds or questioning or affect the validity of the Bonds or the proceedings and authority under which they are to be issued. Neither the creation, organization or existence, of the University nor the title of the current members of the Board of Regents, or other officers of the University to their respective offices is being questioned. There is no litigation pending against the University to enter into the 1977 Supplemental Bond Resolution or to secure the Bonds in the manner provided in the 1977 Supplemental Bond Resolution or the method used in the re-funding program.

## RATINGS

As noted on page 4 of this Official Statement, Moody's Investor Service, Inc., and Standard & Poor's Corporation have given the Bonds the ratings of \_\_\_\_\_ and \_\_\_\_\_, respectively. Such ratings reflect only the respective views of such organizations and an explanation of the significance of such ratings may be obtained from the rating agency furnishing the same. There is no assurance that such ratings will continue for any given period of time or that they will not be revised downward or withdrawn entirely by either or both of such rating agencies if, in the judgment of either or both, circumstances so warrant. Any such downward revision or withdrawal of such ratings, or either of them, may have an adverse effect on the market price of the Bonds.

## MISCELLANEOUS

The references to and excerpts of the Series 1973 Bond Resolution and 1977 Supplemental Bond Resolution contained in this Official Statement are merely summaries of certain provisions thereof and do not purport to be the complete provisions of those documents. Copies of such documents are available from the University or the Underwriters.

Any statements in this Official Statement and Exhibits hereto involving estimates or assumptions, whether or not expressly so stated, are intended as such and no representation whatsoever is made that such estimates or assumptions are correct or will be realized. So far as any statements are made in this Official Statement and Exhibits attached hereto involving matters of opinion, whether or not expressly so stated, they are intended as such and not as representations of fact. Neither this Official Statement, nor any statement that may have been made orally or in writing, is to be construed as a contract with the purchasers or holders of any of the Bonds.

All information contained in this Official Statement and Exhibits is subject to change and/or correction without notice and neither the delivery of the Official Statement nor any sale made hereunder shall create any implication that the information contained herein is complete or accurate in its entirety as of any date after the date hereof.

Reference is made to the Exhibits hereto which are an integral part of this Official Statement and must be read together with the rest of this Official Statement.

---

This Official Statement has been approved by the Board of Regents.

BOARD OF REGENTS OF THE UNIVERSITY  
OF OKLAHOMA

By: Thomas R. Brett, President

Exhibit A

\$6,850,000

ANNUAL DEBT SERVICE REQUIREMENTS

REGENTS OF THE UNIVERSITY OF OKLAHOMA  
UTILITY SYSTEM REVENUE REFUNDING BONDS, SERIES 1977

<u>Date</u> <u>January 1</u>	<u>Debt</u> <u>Service</u> <u>Requirement</u>	<u>Reserve</u> <u>1/</u>	<u>Interest</u> <u>Payments</u>	<u>Coupon</u> <u>Interest</u> <u>Rate</u>	<u>Principal</u> <u>Payments</u>	<u>Princi</u> <u>Balar</u>
1977						
1978					\$100,000	
1979					100,000	
1980					105,000	
1981					110,000	
1982					120,000	
1983					125,000	
1984					135,000	
1985					150,000	
1986					150,000	
1987					170,000	
1988					180,000	
1989					190,000	
1990					205,000	
1991					220,000	
1992					235,000	
1993					245,000	
1994					260,000	
1995					280,000	
1996					285,000 <u>2/</u>	
1997					310,000 <u>2/</u>	
1998					325,000 <u>2/</u>	
1999					340,000 <u>2/</u>	
2000					365,000 <u>2/</u>	
2001					380,000 <u>2/</u>	
2002					405,000 <u>2/</u>	
2003					430,000 <u>2/</u>	
2004					450,000 <u>2/</u>	
2005					480,000 <u>2/</u>	
					<u>\$6,850,000</u>	

Exhibit B

REGENTS OF THE UNIVERSITY OF OKLAHOMA  
STATEMENT OF DEBT SERVICE REQUIREMENTS ON  
SERIES 1973 AND SERIES 1977 UTILITY SYSTEM REVENUE BONDS

<u>Fiscal Year</u> <u>Ending</u> <u>June 30</u>	<u>Series 1973</u> <u>Debt Service</u> <u>Requirement</u>	<u>Series 1977</u> <u>Debt Service</u> <u>Requirement</u>	<u>Combined</u> <u>Debt Service</u> <u>Requirement</u>
1977	\$ 750,625		\$750,625 <sup>1/</sup>
1978	749,750	\$	
1979	753,125		
1980	745,375		
1981	742,250		
1982	743,375		
1983	738,375		
1984	737,625		
1985	735,750		
1986	732,750		
1987	733,725		
1988	733,875		
1989	738,200		
1990	734,900		
1991	740,700		
1992	740,000		
1993	743,100		
1994	739,700		
1995	745,100		
1996	743,700		
1997	740,800		
1998	746,400		
1999	749,900		
2000	751,300		
2001	750,600		
2002	747,800		
2003	<u>757,900</u>		
2004	<u>\$20,066,700</u>		
2005			

<sup>1/</sup> In addition, the debt service of the Series 1975 Bonds which are being advance refunded was \$564,787.50 during the fiscal year ending June 30, 1977.

Exhibit C

HEALTH SCIENCES CENTER  
UNIVERSITY OF OKLAHOMA  
Oklahoma City, Oklahoma

GENERAL DESCRIPTION

of

CENTRAL STEAM & CHILLED  
WATER PLANT

prepared by

CARNAHAN-THOMPSON-DELANO, INC.  
Oklahoma City, Oklahoma



## TABLE OF CONTENTS

- A. HISTORY
- B. SUMMARY OF OVERALL DESIGN
- C. CENTRAL CONTROL SYSTEM
- D. CONTINUITY OF SERVICE
- E. PLANT BUILDING & LANDSCAPING
- F. BUILDING HEATING & COOLING COSTS
- G. MAINTENANCE COSTS
- H. PRODUCTION REPORTS
- I. PRESENT EXPANSION NEEDS
- J. THE NEW LOADS TO BE ADDED
- K. ANNUAL OPERATING RECORDS
- L. ENGINEER'S MONTHLY PRODUCTION REPORT

A. HISTORY:

The University of Oklahoma Medical Center originated with the establishment of University Hospital in 1918. Ten years later, the School of Medicine was moved from Norman to Oklahoma City into new facilities constructed in the Medical Center for this purpose. At that time, a central heating plant was constructed and connected through a tunnel system carrying steam piping to all of the buildings. Children's Hospital was added in 1934, and this and all subsequent buildings were connected to the central heating plant.

In 1965 all State departments and other agencies involved in the expansion and development of the Health Sciences Center formed an organization, the Oklahoma Health Sciences Foundation, Inc., whose function was to coordinate the planning and development of the Center. One of the early significant recommendations was that the old existing power plant was totally inadequate and would have to be replaced.

At this point Carnahan-Thompson-Delano, Inc., an engineering firm in Oklahoma City, was employed to review all existing data and to make an independent feasibility study of power plant requirements. Their report was issued June 17, 1969 recommending that the University build its own steam and chilled water plant and that the construction be in incremental stages in order to provide only the services needed with additions to the plant being constructed only as new major buildings at the Center were under construction and in need of service.

The initial Phase I construction was put into operation in April 1972. Phase II doubled the original plant capacity and was put into operation in October 1974. Considerable savings were realized by not having the total plant constructed initially thereby creating surplus capacity pending construction of new hospitals and other facilities. Phase III & IV construction began in 1975 and completed in 1977, doubled the size of the plant equipment floors and doubled the plant capacities.

B: SUMMARY OF OVERALL DESIGN:

The central steam and chilled water plant and the associated underground distribution system will provide all requirements for these utility services within the Oklahoma Health Center site, some 4000' east and west by 3000' north and south, involving some 40 individual buildings.

The Plant is located in the center of the south side of the site, with a looped distribution system strategically located to provide chilled water and steam service to the various buildings, with the minimum of investment cost consistent with continuity of service.

The ultimate Plant load is estimated to be 18,000 tons of chilled water refrigeration and 300,000 lb. of steam per hour. Chilled water leaves the plant at 40° F, and under heavy loading conditions, will be returned at 52° F. Steam is provided at all the Customer service points at a minimum pressure of 130 lb. per sq. in. The chilled water temperatures are appropriate for all types and designs of air conditioning systems and the steam pressure is adequate for all types of heating apparatus, including the operation of steam laundry equipment, sterilizers in hospitals, cooking and other building uses.

The Plant building consists of a basement floor and a main operating floor, each having approximately 20' head room. In the West end of this space, a 4-story section of rooms exists which houses the management, operation, and control offices for the entire project, along with water treating laboratory, drawings and records room, meter maintenance shop, locker rooms, shower rooms, and similar facilities.

The water chillers are of the steam turbine driven centrifugal type, discharging the exhaust steam into steam condensers, the ultimate heat dissipating apparatus being induced draft water cooling towers. Steam is generated in water tube boilers at 250 lb. per sq. in. dry and saturated, the basic fuel being natural gas with oil standby.

The initial Plant contains one 1000 ton and one 2000 ton water chilling unit, two 60,000 lb/Hr. steam boilers, two 3000 ton capacity cooling tower cells, and appropriate auxiliary equipment. Phase II added a 3000 ton chiller and a 60,000 lb/Hr. boiler. Phases III and IV added a 100' extension of the building, two 3000 ton and one 500 ton chillers and two 60,000 lb/Hr. boilers. Future additions of chillers and boilers will be made as they are needed. All piping within and close to the Plant is designed for ultimate plant capacity.

With reference to the distribution system, the chilled water supply and return mains, the steam supply main, and the steam condensate return main are in underground tunnels provided with proper drainage and adequate ventilation. Valved service connections are placed at strategic locations for connection to future buildings without interruption of services to the original customers along the line.

C. CENTRAL CONTROL SYSTEM:

A computerized central control system (Johnson T-6500) provides a monitoring system for all buildings and areas and will protect the quality of operation while at the same time reducing maintenance and operating costs. It can record and control in specific buildings and areas temperature, humidity, security, report malfunctions, measure quality of service, etc., all from one central point.

Customers may contract for services including any part of the following:

Commands: Start-Stop, Re-set of controller set points, damper setting, valve positioning, lighting on-off.

Monitoring: Alarms with data recording, (off-normal temperature, pressure, humidity, flow, dirty filter, fire, security, doors, etc.).

Programmed Control: Time, or sequential, or dynamic or any combination thereof.

D. CONTINUITY OF SERVICE:

Features have been incorporated in the design in order that the Plant may operate for 10 days isolated from utility systems fuel, electrical energy, and water supply producing 1000 tons of refrigeration and 60,000 lb. steam per hour continuously.

Reliability of the Plant is a very important requirement in consideration of the hospital loads being served and their own requirements for continuous service. It is also necessary to maintain reliability so that ordinary mechanical difficulties will not interrupt service to customers and thereby reduce revenue to the Plant. With these requirements in mind, the engineering design has built reliability into the combining of components into the system. This has been done in a manner not only to assure reliability in operation, but to provide the means for most economical operation under conditions when the loads on the Plant are less than the maximum installed capacity. The following tabulation illustrates this redundancy:

1. Plant Auxiliaries:

Item	Number Installed	Minimum Required
Fuel Oil Tanks	3	1
Fuel Oil Pumps	2	1
Air Compressors	4	2
Air Receivers	5	1
Compressed Air Dryers	4	2
Steam Condensate Transfer Pumps	2	1
Boiler Feed Pumps	8	2
Hot Well Pumps (Each Unit)	2	1
Oil Pumps (Each Turbine & Compressor)	2	1
Combustion Air & Building Ventilating Supply Fans	7	2
Chilled Water Distribution Pumps (1-Turbine Drive, 4-Motor Drive)	5	3
Water Softeners	2	1
Water Wells (with City Standby)	3	0

Plant Auxiliaries (continued)

<u>Item</u>	<u>Number Installed</u>	<u>Minimum Required</u>
Expansion Tanks	2	1
Tunnel Exhaust Fans	3	1
Boiler Chemical Feeders	4	2
City Water Supply Meters	2	1
Deaerating Feed Water Heater	2	1
Boiler Fuel - Natural Gas & Oil	Natural Gas & Oil	
Electrical Power Service	Diesel Engine-Gen. Standby	
Emergency Water Supply	60,000 Gal. Fresh Water Storage	

2. Pipe Line System

Each of the 4 pipe circuits in the tunnel, that is - chilled water supply, chilled water return, steam supply, steam condensate return - have isolating valves in each pipe at approximately 300 foot intervals, with large size air inlet valves on the top of the run at the uphill end of the pipe, and large size bleeder valves at the bottom of the run on the downhill end of the section. In the event of leakage repairs can thus be made very quickly in a matter only of a few hours. Eventually, the distribution system will consist of a looped installation which will allow flow from either direction in the event of a pipe line interruption wherein work must be accomplished on one of the 300 ft. isolation sections.

E. PLANT BUILDING & LANDSCAPING:

The building and the associated cooling tower enclosure have been designed in an Architectural mode under the guidance of the master planning group and consulting architectural personnel, and in keeping with the other new construction in this Medical Center. The Plant site and the existing terrain have been developed in such a manner as to present a most pleasing landscape effect including shrubs, trees, fountains, and decorative illumination. The external appearance of the site will be such that the project will appear more as a conventional building rather than as a power plant, since no mechanical features, such as smokestacks and cooling towers, are visible from the ground level.

F. BUILDING HEATING & COOLING COSTS:

The initial construction was completed and began operating in April, 1972. The old existing plant was removed from service, terminating all costs associated with it, there having been no existing debts against it.

The services purchased from the new facility provide building heating and cooling at a substantially lower cost than can be obtained in any other manner. Diversity of the peak heating and cooling loads between grouped buildings allows serving a load larger than the total of the individual building loads. Planning for future buildings can continue, as in the past, without allocating expensive space for boiler rooms, chiller rooms, smoke stacks, cooling towers, and the associated mechanical apparatus and operating personnel.

In addition to being better and lower in cost than individual building units, this central Plant enjoys a cost advantage in comparison to private enterprise central systems being built in Urban areas. These include exemption from taxes, an institutional power rate lower than is available to private enterprise, and the absence of a profit requirement. The value of these factors is borne out by the fact that there are no known installations of privately owned central plants serving medical centers, universities, or similar institutions.

#### G. MAINTENANCE COSTS:

The apparatus and the piping systems incorporated into the new Plant and tunnel system are of the highest quality available, consistent with the long-term reduced maintenance costs.

As an illustration - the centrifugal water chilling units are Carrier Model 17-M, known throughout the world as the "work-horse of the industry". This is an old and proven design of high efficiency. New and proven products are included where possible - for example, epoxy reinforced fiberglass pipe is used in the steam condensate return system, a mechanical circuit which has been for many years vulnerable to high maintenance by virtue of the never ending corrosive action of the waters on metal pipes.

Automatic controls of the most modern and practical design have been incorporated in order that the Plant may be operated with the minimum of personnel. Surveillance and alarm devices are strategically located throughout the various operating devices in order to give ample warning of malfunctions and erratic operations.

#### H. PRODUCTION REPORTS:

At the end of each month, a complete engineering analysis has been made of every facet of the Plant operation, which is summarized in a "Production Report" by the Consulting Engineers. This analysis serves both to assure efficient operation, and to provide the basis for proper cost allocations between chilled water and steam production. It further provides the summary of actual operating costs which is required to determine the amount of Base Rate Adjustments required to make the revenue from Sales balance the Cost.

At the end of each operating year, the Consulting Engineers prepare an "Annual Report" covering a physical inspection, a survey of management of the business and the operation and maintenance of the properties. This is filed with the Trustee Bank and is available to any bond holder.

#### I. PRESENT EXPANSION NEEDS:

On Page 9 is tabulated "Projected Steam and Chilled Water Loads" from which it may be seen that the present 12,500 ton/240,000 lbs. per Hr. capacity of the plant will be adequate through 1978.

J. NEW LOADS TO BE ADDED:

In addition to the loads shown to be added to the system in 1977 and 1978 in the table Page 9, other proposed projects to be constructed on the Campus within the next three to five years are: The College of Pharmacy, the Oklahoma Allergy Clinic, and additional facilities for the University Hospital.

K. ANNUAL OPERATING RECORDS:

<u>YEAR ENDING</u>	<u>M#/HR.</u>	<u>\$</u>	<u>TON/HRS.</u>	<u>\$</u>	<u>OPER. COST NOT INCL. DEBT SERVICE</u>
June 30, 1973	156,083	446,019	3,304,431	357,570	300,381
June 30, 1974	171,040	332,369	10,112,090	616,717	412,682
June 30, 1975	251,139	473,393	15,173,338	888,587	635,067
June 30, 1976	245,668	656,393	17,452,750	1,337,578	1,031,666
PAST 10 MOS.					
<u>ENDING</u>					
June 30, 1977	276,810	794,696	18,508,752	1,465,686	1,280,473

L. ENGINEER'S MONTHLY PRODUCTION REPORT:

FOR THE MONTH OF APRIL 1977

	CURRENT MONTH		THIS PAST 12 MONTHS	LAST CALEN YEAR
	THIS YEAR	LAST YEAR		
STEAM PRODUCED M LBS.				
GENERATED	49,546	39,209	599,621	557,128
PLANT USE	3,092	3,357	34,540	36,831
NET OUTPUT	46,454	35,852	565,081	520,297
CH-H <sub>2</sub> O PRODUCED TON-HRS.				
GENERATED	1,899,044	1,580,794	23,743,434	22,959,503
PLANT USE	26,035	101,603	873,000	746,690
NET OUTPUT	1,873,009	1,479,191	22,870,434	22,212,813
PEAK PRODUCTION RATES				
STEAM LBS./HR	117,000	90,000	133,000	123,000
CH-H <sub>2</sub> O TONS	3,430	4,514	6,833	6,833
GPM	9,300	9,000	13,800	13,800
UTILITIES				
GAS MCF	56,017	51,807	724,414	672,485
OIL GALS.	10	10	3,790	3,770
ELECT. KWH	982,800	696,000	11,218,800	10,596,000
H <sub>2</sub> O M GALS.	8,806	6,378	97,660	89,534
UTILITY ALLOCATIONS				
KWH-STEAM	196,560	139,200	2,243,760	2,119,200
CH-H <sub>2</sub> O	697,788	494,160	8,063,616	7,621,428
M GAL. H <sub>2</sub> O-STEAM	2,842	1,724	24,552	19,916
CH-H <sub>2</sub> O	5,417	4,354	65,243	63,858
M GAL. COND. LOSS	560	571	7,875	6,107
UNITS PER LB. STEAM				
BTU	1,228	1,474	1,309	1,319
RAW WATER LBS.	.51	.40	.36	.32
KWH/M LBS.	4.23	3.88	3.97	4.07
UNITS PER TON-HR. CH-H <sub>2</sub> O				
STEAM LBS.	10.42	9.80	10.28	10.31
RAW WATER GALS.	2.85	2.75	2.75	2.78
KWH	.37	.31	.34	.33
TUNNEL STEAM M LBS.				
INPUT	26,969	20,357	322,670	284,404
SALES	24,424	20,286	306,312	272,815
LOSSES: M LBS.	2,545	71	16,358	11,589
COND. % RETURNED	83.1	77.2	80.2	82.6
TUNNEL CH-H <sub>2</sub> O TON HRS.				
INPUT	1,873,009	1,479,191	22,870,434	22,212,813
SALES	1,847,160	1,411,455	21,910,061	21,278,588
LOSSES: TON-HRS.	25,849	67,736	960,373	934,225
FLOW--M GAL.	377,006	293,292	4,412,555	4,237,662
AVG. TEMP. DIFF.	7.15	7.26	7.46	7.55



	CURRENT MONTH		THIS PAST 12 MONTHS	LAST CALENDAR YEAR
	THIS YEAR	LAST YEAR		
<b>PRODUCTION COST</b>				
PAYROLL	\$ 18,526.75	\$ 15,215.54	\$ 185,254.88	\$ 173,166.49
OP. SUPPLIES	7,353.12	1,355.97	31,329.26	25,053.41
MOTOR POOL	213.43	127.11	2,379.57	2,417.84
TELEPHONE	81.97	68.82	1,096.27	1,217.48
GAS	74,230.57	45,490.28	884,017.53	745,164.23
WATER	80.70	80.00	1,518.74	1,293.82
ELECT.	18,356.20	7,084.07	205,602.86	182,044.63
SEWER	67.50	67.50	822.90	822.90
TUNNEL REPAIR	0	1,342.77	10,742.11	13,673.90
CONTROL SERVICES	9,185.81	5,045.63	89,518.54	75,100.88
<b>ADMINISTRATIVE COST</b>				
PROF. SERVICES	1,090.00	4,230.00	10,179.50	13,154.50
SPECIAL MAINT.	2,753.85	808.14	16,268.85	9,675.78
INSURANCE	1,651.83	1,598.33	19,661.46	29,787.99
TRUSTEE FEE	0	0	13,480.06	12,603.28
DEBT SERVICE	109,576.08	99,971.53	1,244,389.62	1,207,471.42
<b>TOTAL COST</b>	<b>\$ 243,167.81</b>	<b>\$ 182,485.69</b>	<b>\$2,725,024.16</b>	<b>\$ 2,500,410.61</b>
<b>SALES</b>				
STEAM	\$ 71,410.07	\$ 55,836.62	\$ 885,879.78	\$ 762,902.41
CH·H <sub>2</sub> O	163,921.80	122,157.58	1,753,908.15	1,663,725.62
CONTROL	7,835.94	4,982.40	85,227.16	73,813.00
EXTRAS	0	0	9.07	9.07
<b>TOTAL</b>	<b>\$ 243,167.81</b>	<b>\$ 182,976.60</b>	<b>\$2,725,024.16</b>	<b>\$ 2,500,450.10</b>
<b>UNIT COST SUMMARY</b>				
STEAM/M LBS.	\$ 1.54	\$ 1.56	\$ 1.57	\$ 1.47
CH·H <sub>2</sub> O/TON-HR.	.088	.082	.077	.075
ELECT./KWH	.020	.015	.018	.017
GAS/MCF	1.37	1.01	1.22	1.10

<u>1973</u>	<u>1976</u>		<u>1977</u>	<u>STEAM</u> <u>LB/HR.</u>		<u>1978</u>	<u>STEAM</u> <u>LB/HR.</u>
<u>PEAK PLANT LOAD</u>	<u>ADDED LOAD</u>		<u>TONS</u>			<u>TONS</u>	
2,700 Tons 60,000 lb/Hr.	Child Study Center	⊙ C.M.H. West Add.	710	10,650	⊙ Health Sciences Library	533	5,700
	Biomedical Sciences	⊙ C.M.H. East Add.	490	7,500	+ Oklahoma City Clinic	200	1,400
	Dental Sciences	▲ Service Center Rmdl.	70	3,600	⊙ College of Health	170	1,800
	McGee Eye Clinic	▲ Interim.Bldg. Rmdl.	100	-	+ O.M.R.F. Add.	300	3,600
<u>1974</u>		▲ Univ. Hospital Rmdl.	100	2,000			
<u>PEAK PLANT LOAD</u>		▲ Biomedical Sciences	700	28,000			
2,775 Tons 76,000 lb/Hr.		⊙ O.P.D. Add. - Linear Accelerator	200	-			
		▲ College of Dentistry	700	17,650	90% Diversity		11,250
<u>1975</u>		▲ Presbyterian Hospital New Floors Opened	200	3,000			
<u>PEAK PLANT LOAD</u>	<u>ACTUAL PEAK PLANT LOAD</u>	▲ Presbyterian Doctor's Office Building	200	2,600	<u>ESTIMATED PLANT LOAD</u>		
5,490 Tons 93,500 lb/Hr.	5,410 Tons 104,000 lb/Hr.	⊙ College of Nursing	290	2,100	10,370 Tons 184,600 lb/Hr.		
			3,760	77,100			
		90% Diversity		69,390			
		<u>ESTIMATED PLANT LOAD</u>					
		9,470 Tons 176,600 lb/Hr.					

LEGEND

- ▲ Existing Building
- ⊙ Under Construction
- + Planning in Progress

PHASE I CONSTRUCTION

PLANT CAPACITY

3,000 Tons  
60,000 lb/Hr.

PHASE II CONSTRUCTION

PLANT CAPACITY

6,000 Tons  
120,000 lb/Hr.

PHASES III AND IV CONSTRUCTION

PLANT CAPACITY

12,500 Tons  
240,000 lb/Hr.

PROJECTED STEAM AND CHILLED WATER LOADS

Exhibit D

REGENTS OF THE UNIVERSITY OF OKLAHOMA  
UTILITY SERVICE AGREEMENT

This Utility Service Agreement (hereinafter called "Agreement") dated as of July 1, 1973, by and between \_\_\_\_\_ (hereinafter called "CUSTOMER") and the Board of Regents of the University of Oklahoma (hereinafter called "OWNER").

W I T N E S S E T H :

WHEREAS, the operation of the University of Oklahoma Health Science Center is under the control and supervision of the OWNER; and

WHEREAS, heating and cooling services are essential to the proper and efficient performance of the duties and work of the OWNER in the operation of the University of Oklahoma Health Science Center and related facilities; and

WHEREAS, the OWNER has determined to acquire the existing facilities and construct additional facilities required for the provision of heating and cooling services to the University of Oklahoma Health Science Center and certain buildings housing institutions related thereto that could be served by the OWNER which are contained in the Oklahoma Health Science Center (hereinafter called the "Project" which together with all additions, betterments, improvements thereto and extensions thereof hereafter constructed or acquired by the OWNER are called the "Facilities"); and

WHEREAS, to pay the cost of acquiring and constructing the Project and to capitalize certain reserve requirements, the OWNER has determined to initially issue its Utility Revenue Bonds, Series 1973 (hereinafter called "Bonds") dated July 1, 1973, in the aggregate principal amount of \$10,125,000, under and pursuant to the terms of a Bond Indenture

(hereinafter together with all supplements thereto called the "Indenture")  
dated as of July 1, 1973.

WHEREAS, in consideration of the OWNER's agreement to acquire and install the Project, the CUSTOMER has determined to purchase heating and/or cooling services from the OWNER.

NOW, THEREFORE, THE OWNER AND THE CUSTOMER AGREE AS FOLLOWS:

1. The CUSTOMER hereby agrees to purchase from the OWNER and the OWNER hereby agrees to furnish, all steam, chilled water and other services required to provide the central heating and cooling for the buildings of the CUSTOMER located adjacent to the University of Oklahoma Health Science Center in Oklahoma City. The term of this Utility Service Agreement shall be from the first day of July, 1973, to the thirtieth day of June, 1974. Until the Bonds and all additional parity bonds, or any other indebtedness of the OWNER secured by the Indenture are retired in full, this Utility Service Agreement shall be automatically renewed on July 1, 1974, and on the first day of each July thereafter, for annual periods ending on the June 30th following each such renewal, each such renewal to be accomplished automatically unless notice in writing is given as hereinafter provided. If the CUSTOMER determines that it does not wish the contract to be automatically renewed after any then next ensuing 12:01 A.M., July 1, it shall give notice in writing, to that effect, at least one (1) year in advance of the said July 1 by serving said notice on the OWNER and the Bank. The CUSTOMER hereby agrees to not purchase heating and cooling services for its buildings located adjacent to the University of Oklahoma Health Science Center from anyone other than the OWNER as long as this contract is in effect, except for such services that are beyond the design capacity of this Project. The CUSTOMER further agrees to not

build a heating and cooling system to provide services to its buildings located in the Oklahoma Health Science Center as long as this contract is in effect, except for such services that are beyond the design capacity of this Project.

2. "Satisfactory Service" as used herein shall mean the supplying of heating and cooling services sufficient in quantity to meet the needs of the CUSTOMER's buildings existing or under construction in the Oklahoma Health Science Center as of July 1, 1973. The CUSTOMER hereby agrees to cooperate in all ways necessary to assist the OWNER in furnishing satisfactory service.

3. The CUSTOMER hereby agrees to pay, from legally available revenues, for said heating and cooling services, rates and charges to be determined by the OWNER and reviewed by the OWNER according to other provisions herein. Such rates, when so fixed, plus revenues derived from other sources, shall produce sufficient revenue (1) to provide in any year, revenues equal to the annual principal and interest requirements on the Bonds and any indebtedness of the OWNER payable from the gross revenues of the Facilities which is incurred in order to provide satisfactory service as hereinbefore defined, (2) to meet the Reserve Account, Repair and Replacement Fund, and Redemption Fund requirements on the Bonds as specified in the Indenture, and any other indebtedness of the OWNER payable from the revenues of the Facilities which is incurred in order to provide satisfactory service as hereinbefore defined, and (3) to pay the operation and maintenance expenses of or related to the Facilities.

4. (to be included in Agreements of State Agencies only) The CUSTOMER's liability for payment for heating and cooling services actually provided under this Agreement shall be subject to an appropriation having been made from which its obligations hereunder may lawfully be discharged, or there being other monies lawfully available from which such obligations

may be discharged. The CUSTOMER agrees (1) to apply such other monies to the extent required to satisfy its obligations hereunder and (2) to include in its budgets required to be submitted to any officer, board or commissioner in the executive branch preparing budgets to be submitted to the Legislature, or if there shall be no officers, boards or commissioners preparing such budgets, to include in their budgets to be submitted directly to the Legislature, amounts sufficient to enable it to meet its obligations hereunder. The CUSTOMER hereby agrees to commence payments to the OWNER on such date that service may be available.

5. The rates to be paid by the CUSTOMER to the OWNER shall consist of "Cost of Service" rates and "Base Rate Adjustment." Cost of Service rates shall be established by the OWNER, with the assistance of professional engineers, prior to the original provision of heating and cooling, i. e., steam and chilled water, service and initially as set out on Appendix A. Such rates, which shall be reviewed by the OWNER and the professional engineers and, if required, adjusted each June and December, shall be maintained at a level sufficient to provide no less than that required to meet the requirements of paragraph (3) above. Such Cost of Service rates shall be based on the amount, type and conditions of the service as provided in Appendix B. The rates shall be applied at each metered point of service.

6. The Cost of Service rates may be adjusted on a monthly "plus" or "minus" basis as a percentage of the monthly dollar billing, derived from said Cost of Service rates, without limitation, through the application of a Base Rate Adjustment.

7. A "plus" Base Rate Adjustment could result and shall be enforced when the revenues derived from the Cost of Service rates are not sufficient to meet the principal and interest requirements on the Bonds and any indebtedness of the OWNER that is payable from the revenues of the Facilities which is incurred in order to provide satisfactory service as hereinbefore

defined; the operation and maintenance expenses of the Facilities; and the amounts necessary to maintain the Reserve Account, Repair and Replacement Fund, and the Redemption Fund (all as defined in the Indenture) at minimum stated levels.

8. A "minus" Base Rate Adjustment could result when the revenues derived from the "Cost of Service" rates exceed the amounts required to meet the actual principal and interest requirements on the Bonds and any indebtedness of the OWNER that is payable from the revenues of the Facilities which is incurred in order to provide satisfactory service as hereinbefore defined; the operation and maintenance expenses of the Facilities; the amounts necessary to maintain the Reserve Account, Repair and Replacement Fund, and the Redemption Fund (all as defined in the Indenture) at minimum stated levels, in the stated order of priority, and within the allotted time periods.

9. During any period or periods, in which any customer, or customers, of the OWNER, who have purchased fifty percent (50%) or more of the heating and cooling services produced by the Facilities during the next preceding twelve-month period, do not purchase heating and cooling services as required by Utility Service Agreements, the rates and charges, including both the Cost of Service rates and the Base Rate Adjustment to be paid by the CUSTOMER shall not exceed more than 200% of the highest monthly rates and charges paid by the CUSTOMER during the next preceding twelve-month period.

10. The Conditions of Service and CUSTOMER's Instructions attached hereto as Appendix B are incorporated herein. For the purposes of said Appendix, the term "Design Demand Peak" defined in said Appendix for chilled water service shall initially be \_\_\_\_\_ tons and for steam service shall initially be \_\_\_\_\_ lbs. per hour. The Design Demand Peaks may be changed by agreement of the parties hereto.

11. In the event of the OWNER's default under the Indenture, which

default results in the appointment of temporary or permanent receivers or Trustees of the Facilities, the CUSTOMER hereby agrees to perform with respect to such receivers or Trustees, all covenants and agreements herein undertaken with respect to the OWNER.

The OWNER hereby agrees to not terminate service to the CUSTOMER except for non-payment of charges or for breaches of this Agreement as determined by the OWNER to be material.

IN WITNESS WHEREOF, the CUSTOMER has caused this instrument to be signed by its Chairman and Secretary and its seal affixed and the OWNER has caused this instrument to be signed by its Chairman and Secretary and its seal affixed, all as of the day and year first above written.

ATTEST:

\_\_\_\_\_  
(SEAL)

\_\_\_\_\_  
BOARD OF REGENTS OF THE UNIVERSITY  
OF OKLAHOMA

\_\_\_\_\_  
President

ATTEST:

\_\_\_\_\_  
Secretary

(SEAL)





APPENDIX A

RATE SCHEDULE

STEAM

Demand Charge: \$75.00 per 1,000 lbs. per hour per month  
(Minimum \$75.00)

Consumption: \$1.00 per 1,000 lbs.

CHILLED WATER

Demand Charge: \$3.00 per ton per month  
(Minimum \$300.00)

Consumption: \$.03 per ton-hour

Differential temperature adjustment applied monthly  
to Consumption:

plus 3% per degree below 12<sup>o</sup>F  
or minus 3% per degree below 14<sup>o</sup>F

APPENDIX B  
CONDITIONS OF SERVICE  
AND  
CUSTOMER'S INSTRUCTIONS

I. DEFINITIONS

A. Ton: As used herein, references to a "ton" of refrigeration capacity are intended to refer to a "ton" of refrigeration capacity as defined in the 1965-66 Guide and Data Book published by the American Society of Heating, Refrigerating and Air Conditioning Engineers, being the equivalent of the cooling capacity of one ton of ice melting in a period of twenty-four hours (i.e. 288,000 Btu, or an average of 12,000 Btu/hr.)

B. Ton-Hours: Likewise, in accordance with the definitions contained in said 1965-66 Guide and Data Book, a "ton-hour" of chilled water as used herein is intended to refer to the quantity of chilled water delivered by Owner to Customer at the chilled water delivery point at a temperature which will produce the equivalent of 12,000 Btu of cooling in Customer's Facilities (from point of delivery thereto to point of redelivery to Owner) over a period of one hour, also taking into account, of course, the temperature of the quantities of chilled water redelivered by Customer to Owner at the chilled water redelivery point, and measured and calculated on the basis of the aggregate Btu gain occurring in the quantities of chilled water delivered by Owner to Customer between the chilled water delivery point and the chilled water redelivery point provided for herein and in accordance with the procedures and methods provided for herein.

C. Owner: As used herein, "Owner" refers to the Board of Regents of the University of Oklahoma or its designate.

D. Customer: As used herein, "Customer" refers to the party with whom Owner has entered into the service agreement to which this is attached and incorporated as Appendix B.

E. Service Agreement: As used herein, "Service Agreement" refers to that Utility Service Agreement to which this is attached and incorporated as Appendix B, entered into between Owner and Customer whereby Owner agrees to furnish steam for heating (and processing) and chilled water for cooling and Customer agrees to purchase same in accordance with the terms and conditions of the agreement and the conditions of service and Customer's instructions herein.

## II. NATURE, AVAILABILITY & REQUIREMENTS RELATING TO USE OF SERVICE

A. Steam Plant: Owner will render heating service from a central steam plant and a distribution system providing a primary supply of saturated steam to its customers for heating and processing, at a pressure ranging from 125 to 100 psig depending on point of delivery and the load on the system.

Condensate shall be pumped from the premises by the Customer to the Owner's condensate return mains and thence back to the Central Plant at a normal pressure of 25 psig, but in no event to exceed 50 psig, at a minimum temperature of 180<sup>o</sup>F. No condensate from process steam which is contaminated shall be pumped back into the Owner's condensate return system but shall be disposed of by Customer. No Customer may tap into or otherwise interfere with the flow of such condensate without the prior written permission of Owner.

B. Steam Service: Steam Service may be purchased from Owner for all heating and processing purposes by the use of customer-owned equipment which is connected or can be connected to Owner's steam distribution system after Owner and Customer have executed a written service agreement. Owner may refuse to accept condensate from Customer if condensate has been contaminated by Customer. Customer shall not do any water treatment nor add any chemicals or foreign substances into the water being used in its heating and cooling system without the prior written consent and

approval of Owner, such approval not to be unreasonably withheld by Owner.

C. Cooling Plant: The Owner will render cooling service by means of water chillers, pumps, and associated facilities located at its central plant and by a chilled water distribution system, designed to deliver chilled water at the Customer's point of delivery at 40 to 42°F, and at pressures varying from 120 psig to a maximum of 200 psig and to receive back the chilled water at Customer's point of return at approximately 55°F. Customer shall furnish controls to maintain a programmed water temperature differential of 14°F, plus or minus 1°F above delivery temperature after use by the Customer at point of return of chilled water to Owner's system. Customer will return the chilled water to Owner at the point of return at a sufficient pressure to meet the pressure requirement of Owner's chilled water return system. No Customer may tap into, use or otherwise interfere with such chilled or return water in any way which may raise or lower its temperature beyond the above stated limits. Customer shall not in any way contaminate the chilled water while same is in Customer's custody and control.

D. Cooling Service: Chilled water service may be purchased from Owner for the cooling requirements of buildings which are connected or can be connected to the Owner's chilled water distribution system when the Customer and Owner have executed the Utility Service Agreement.

E. Preparation of Customer's Piping System to Receive Service: This service condition pertains to the cleanliness of the Customer's chilled water, steam and steam condensate piping systems and connected heat transfer apparatus, both new systems and existing systems.

After the Customer's chilled water piping system is completed and before it is connected to the Owner's service lines, the piping shall be washed clean, The cleaning solution shall be trisodiumphosphate and water, concentration as recommended by the chemical manufacturers for this duty. This solution shall be pumped through the piping at such a rate as to

remove oil, mill scale, etc. Discard and drain. Repeat this operation twice. At the end of the second flushing period, check ph of water in system (Litmus paper) and if not neutral, repeat flushing or neutralize with appropriate chemical. Any leaks which develop as a result of the cleaning operation shall be repaired by the Customer.

After the Customer's steam and steam condensate piping system is completed, it shall be cleaned as set forth below, before the steam condensate return piping is connected to the Owner's return system.

Steam service shall be connected to the Customer's system and placed into operation, with all condensate from the Customer's system dumped to waste, until the return line flow is clear of mill scale, oil, pipe dope and all debris. Steam used for this cleaning operation will be billed to the Customer at \$1.00 per 1000 pounds total charge. Any leaks which develop shall be repaired by the Customer.

F. Flow Control - Chilled Water Loads: The flow of chilled water through the Customer's heat transfer systems shall be automatically stopped when the air conditioning systems are turned off. The automatic valves shall be capable of 100% shutoff at differential pressure up to 75 psig. In the event that freeze protection is desired on a dormant coil, 10% of design flow through a manual bypass valve, around the automatic valve will be allowed.

### III. METERS & SPACE REQUIREMENTS

The Owner will furnish, install and maintain meter runs and consumption meters best suited to the service requirements. The Customer will furnish, install and maintain such pressure regulating valves or pumps required to change inlet and return pressures or flows.

The metering devices are to be checked for accuracy in accordance with generally accepted methods at least once every year by the Owner in the presence of Customer's representative.

Customer will provide, without charge, adequate space if required on its premises for the housing of and access to such measuring equipment and appurtenances.

#### IV. OWNER'S SERVICE LINES

The Owner will install its service lines to a location at the outside wall of the basement or foundation of Customer's building, determined by the Owner to be convenient and practicable, and will extend such service lines through a sleeve provided and installed by the Customer in such basement wall or foundation to the point of the Owner's metering facilities. The point on the discharge side of the Owner's meters, (for recording consumption of steam and chilled water by Customer) shall constitute the point of delivery of service, the point on the inlet side of the Owner's meter installed to record condensate return shall constitute the condensate return point and the point where Owner extends its service lines to receive chilled water from Customer shall constitute the point of return of chilled water. Steam service will normally be supplied to the Customer's building through a single supply line and a single condensate return line. Chilled water service will normally be supplied to the Customer's building through a single supply line and a single return line. For reasons of Owner's economy, conditions on the Owner's distribution system, improvement of service conditions, or volume of the Customer's requirements, the Owner may at its option install more than one service line for steam service, or chilled water service, or both.

The Owner reserves the right to determine the location of any service line, and to avoid misunderstanding, the Customer, before starting work, shall consult the Owner as to the exact location of the point of service termination (or delivery point). Owner agrees to act reasonably in respect to the determination of the location of said line.

Any change requested by the Customer in the point of delivery of service or location of Owner's service facilities, provided such change is

approved by the Owner, will be made at the expense of the Customer, who shall reimburse the Owner for the actual cost of such change.

#### V. OWNER'S PROPERTY

The service line, meters, and service equipment installed by the Owner shall remain the property of the Owner.

The service stop valve and meter stop valves shall be operated only by authorized personnel of the Owner, except that the service stop valve and meter stop valves may be closed by the Customer after shutoff. The Owner shall be notified immediately of such shutoff. The Owner's representative, if requested, shall exhibit his written authority.

The Customer shall be responsible for the safekeeping of the Owner's property on his premises. No person, except a duly authorized employee of the Owner, shall be permitted to break or replace an Owner seal or lock, or to alter or interfere with the operation of meters or its connections ( a steam meter, a water meter), regulators, or any other item of service equipment installed by the Owner.

#### VI. CUSTOMER'S PROPERTY

The Customer will furnish, install and maintain, where required, on the service side of the meter, such pumps and regulating devices as are necessary to maintain pressure and flow conditions required by Customer equipment and return at distribution operating pressure conditions which will meet the requirements herein.

The Customer shall provide (without cost to Owner) suitable space for the installation, inspection, protection, and maintenance of Owner's meters and other necessary service equipment within Customer's premises, at a location acceptable to Owner and as near the point of delivery as practicable. Where electricity or instrument air is required for the operation of the Owner's meters or meter regulating valves, the Customer shall furnish and install wiring, piping, and equipment necessary to provide such service.



The Customer shall also furnish, install and maintain all facilities required for his utilization of service as shown on Pages 11 to 15 of this Appendix B.

Except as otherwise provided herein, all repairs to Customer's piping and equipment shall be made by the Customer. The Customer shall give immediate notice to the Owner of any leakage or escape of steam or chilled water.

The Customer shall give the Owner reasonable advance notice of intention materially to increase or decrease his load. Changes and alterations to provide proper metering in such cases shall be governed by Owner's requirements applying to new installations.

The Owner shall not be required to supply steam service until the Customer's installation shall have been approved by any local authority having jurisdiction over the same, and the Owner further reserves the right to withhold its service, or discontinue its service, whenever such installation or part thereof is deemed by the Owner to be unsafe, inadequate or unsuitable for receiving the Owner's service, or to interfere with or impair the continuity or quality of the Owner's service to the Customer or to others.

#### VII. ACCESS TO PREMISES

The Owner's duly authorized representative shall have the right of access to all the Owner's property on the premises of the Customer and on all other premises, with respect to which the Customer has secured easements, at all reasonable times for the purpose of installing service lines, inspecting, protecting, maintaining, and replacing where necessary, its service lines, meters, and service equipment, removing its property, or any other proper purpose.

#### VIII. LIABILITY

The Owner will endeavor at all times to provide a regular and uninterrupted supply of service throughout the year on a twenty-four (24) hour

per day basis, but does not warrant or guarantee uninterrupted service and shall not be liable for any damages caused or resulting from an interruption in service. Nor shall the Owner be liable for any injury or damage resulting in any way from the supply or use of the steam or chilled water or the presence of its equipment on the Customer's premises, and neither by inspection or non-rejection, nor in any other way, does the Owner give any warranty, expressed or implied, as to the adequacy, safety or other characteristics of any structures, equipment, wires, mains, pipes, applicances, or devices owned, installed or maintained by the Customer or leased by the Customer from third parties.

#### IX. NOTICES

The Customer shall give the Owner five (5) days' prior written notice to turn on or turn off steam or chilled water service.

#### X. METERING & BILLING

A. Measurement of Steam Service: Metering of the Customer's usage of steam (supply and return of condensate) will be determined by use of Owner's flow meters which will record the Customer's usage. Customer shall return no less than 95% of condensate volume per month to Owner. Owner may penalize Customer for returning less than the indicated 95% of condensate at a penalty rate equivalent to 0.40 times the average steam consumption rate for such shortage.

B. Measurement of Chilled Water Service: Metering of the Customer's usage of chilled water supply and return will utilize a device which measures and records chilled water flow and water temperature difference to be converted to ton-hours. Customer shall return all of the chilled water volume delivered by Owner to Customer. Owner may penalize Customer for not returning all of the chilled water at a penalty rate equal to two times the cost to Owner of water furnished to Owner by its supplier.

C. Billing Demand: The billing demand for steam and for chilled water services in which the DEMAND CHARGE is computed, shall be the largest number of pounds of steam, or ton-hours of refrigeration, in any sixty (60) minute period during the month; provided, however, that the billing demand shall be not less than the highest billing demand established during the preceding eleven (11) months; and provided further that the billing demand in any month shall not be less than eighty (80) percent of the Service Design Peak. The Service Design Peak shall be the maximum rate of delivery based on the Customer's requirements, and as agreed between Customer and Owner as set forth in the Service Agreement.

D. Meter Reading & Billing Period: The regular meter reading and billing period shall be a calendar month. The Owner reserves the right to read meters and render bills at any other intervals of time.

E. Bills Based Upon Estimated Usage of Service: Should the meter record be interrupted at any time and for any reason, the quantities of steam or chilled water to be billed for such period of interruption will be estimated from meter records immediately before and after the period of interruption.

F. Payment of Bills: Bills of the Owner for service are due on presentation and payable within fifteen (15) days thereafter.

## XI. RATES

A. Steam Service: The monthly charge for steam service shall be based on a two-part rate consisting of a Demand Charge and a Consumption Charge as contained in the Rate Schedule attached to the Service Agreement. The Demand Charge shall be computed on the basis of the Steam Billing Demand as defined hereunder in Section C of Article X. Such charge is due and payable each and every month without regard as to whether steam was delivered during the month. The Consumption Charge shall be computed based on the volumes of steam delivered during the month to Customer.

B. Chilled Water Service: The monthly charge for chilled water service shall be based on a two-part rate schedule consisting of a Demand Charge and a Consumption Charge as contained in the Rate Schedule attached to the Service Agreement. The Demand Charge shall be computed based on the chilled water billing demand as defined herein in Section C of Article X. Such charge is due and payable each month without regard as to whether chilled water was delivered during the month. The Consumption Charge shall be computed based on the ton-hours of cooling delivered during the month to Customer.

C. Chilled Water Temperature Differential: The differential temperature used for chilled water consumption adjustment will be computed as that temperature which, when applied to the metered total quantity of water delivered during the month, would produce the ton-hours of consumption metered during the same period.

D. Exhaust Air From Customer's Buildings: The tunnel system will be maintained at a slight negative pressure by exhaust fans located near the central plant; the air being discharged to atmosphere after flowing through the plant building. Customers are encouraged to take advantage of this exhaust facility, and discharge exhaust air into the tunnel system. Air exhausted into the tunnel shall be relatively clean, free from strong odors, radioactive materials, bacteria, virus, and at a temperature not to exceed 80°F. Normal toilet exhaust air systems and normal building exhaust air will be acceptable. Kitchen exhaust, laundry exhaust, laboratories exhaust and similar air streams will not be acceptable.

Owner reserves the right to accept and/or reject any exhaust air stream, and assumes no obligation for reversal of flow into the Customer's exhaust air system.

The Customer agrees to not provide heating and cooling service (on a re-sell basis) without the permission of the Owner.

# STEAM METERING STATION

125 P.S.I.G.    1.5<sup>#</sup>/SQ.IN. LOSS/100 FT. MAX.

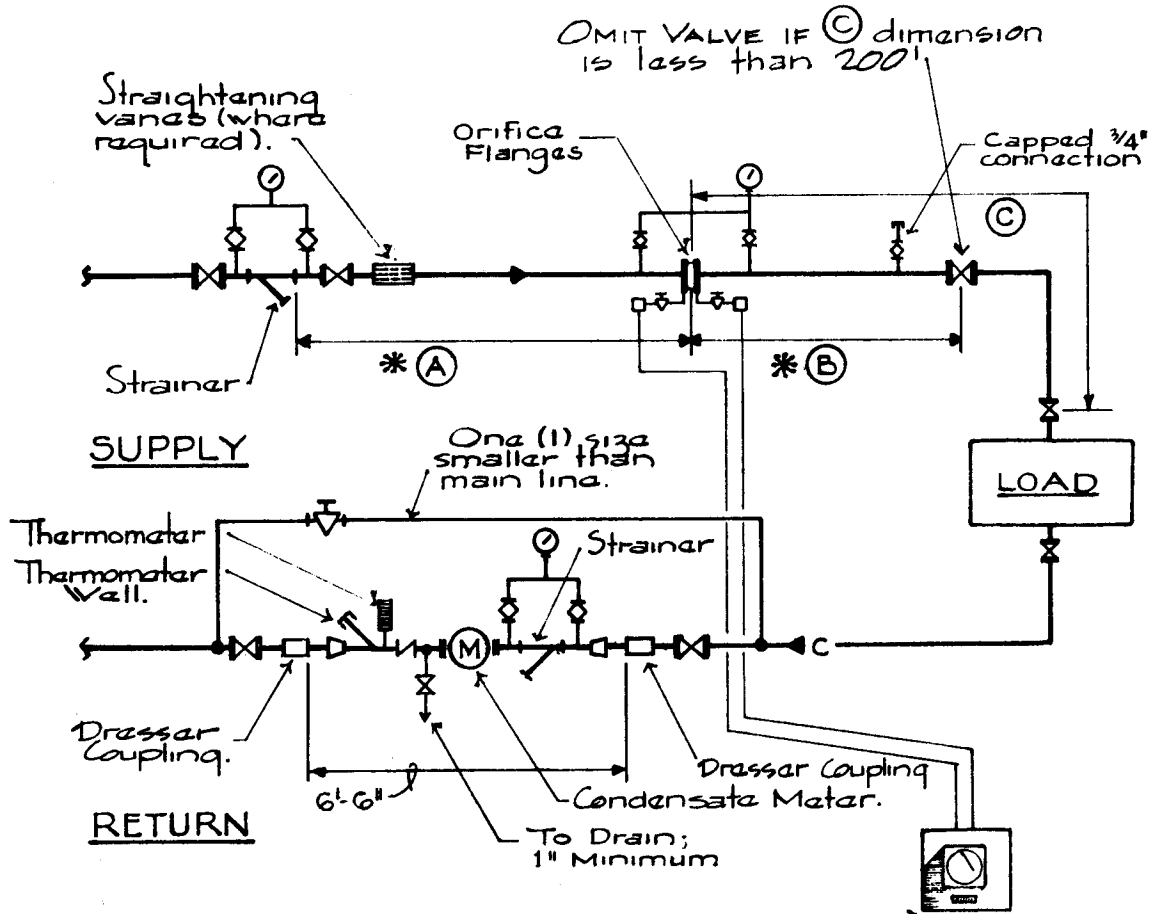

**VALVES:**

Line size, O.S. & Y gate valves, with chain wheels & chains where handwheels are above 7'-0".

\* Depends on line size, see schedule. (Sketch #1013-2)

Steel metering enclosure, see details, Sketch #1013-5

REVISED 5-31-1972

REVISED 7-15-1970

**SKETCH #1013-1**

PREPARED BY:

**CARNAHAN & THOMPSON  
ENGINEERS**

OCTOBER 14, 1969

# STEAM FLOW METERS

125 P.S.I.G. — 1.5#/SQ. IN. LOSS/100 FT. MAX.

SIZE: INCHES	LBS. PER HOUR	LOSS/ 100 FT. LBS.	VELOCITY FT./ MINUTE	30 DIAM. UPSTREAM * (A) MIN.	3 D. AM. DOWNSTREAM * (B) MIN.
3"	750	0.06	500	9'	1'
3"	4300	1.50	2800	9'	1'
4"	4600	0.40	1600	10'	2'
4"	9500	1.50	3300	10'	2'
6"	10,000	0.25	1600	15'	2'
6"	30,000	1.50	4000	15'	2'
8"	31,000	0.50	3000	20'	3'
8"	63,000	1.50	5200	20'	3'

\* See piping illustrations on following drawings: sketch #1013-1

REVISED 5-31-1972  
REVISED 7-15-1970

<p><u>SKETCH #1013-2</u> PREPARED BY: <u>CARNAHAN &amp; THOMPSON</u> <u>ENGINEERS</u> OCTOBER 14, 1969</p>
--

# CHILLED WATER METERING STATION

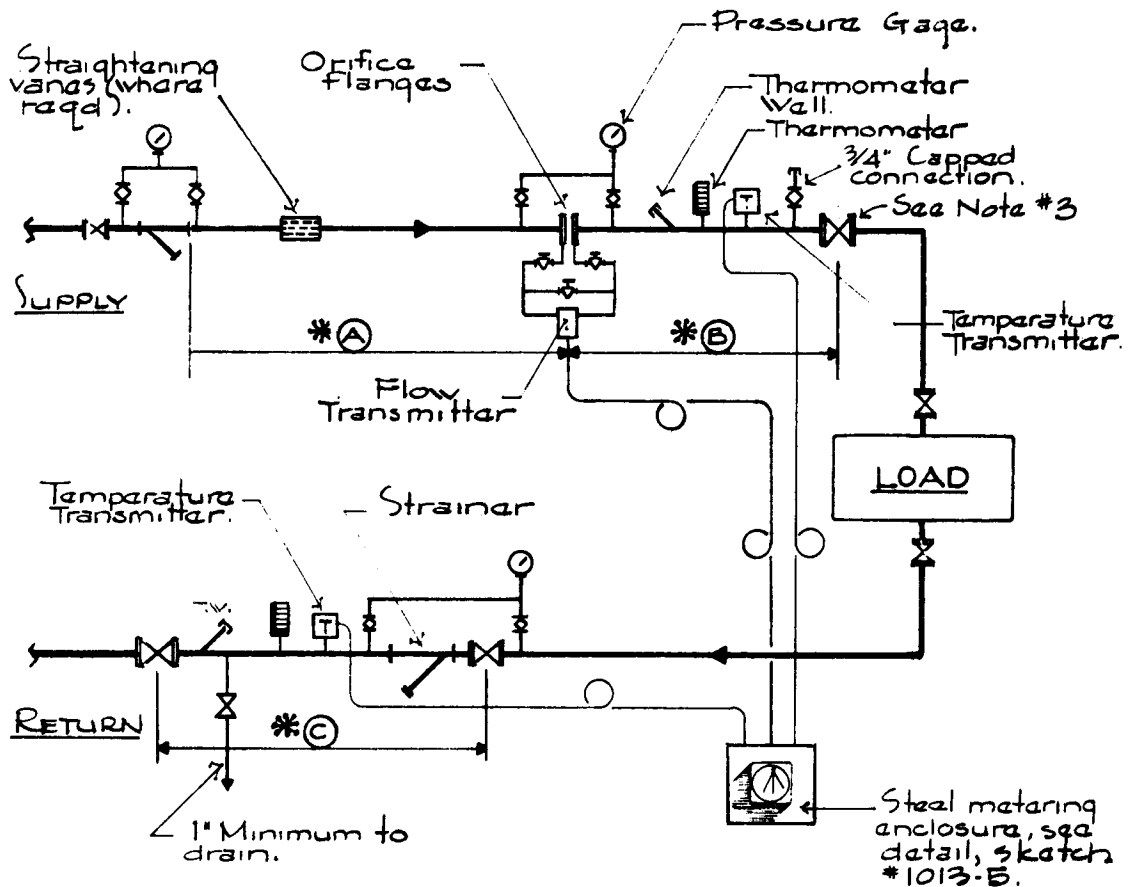

Notes:

1. Valves shall be line size, lug-type butterfly with gear operators. Chain wheels and chains shall be provided where hand wheels are above 7'-0".
2. Orifice flanges, temp. and pressure sensing devices shown in this illustration must be in a room provided within customer's building or in run-out tunnel.
3. Omit valve if distance from load valve to orifice flange is less than 200'.

\* Depends on pipe size, see schedule sht. 1013-4.

REVISED 5-31-1972

REVISED 7-15-1970

SKETCH #1013-3

PREPARED BY:  
CARNAHAN & THOMPSON  
ENGINEERS

OCTOBER 14, 1969

# B.T.U. METERS FOR CHILLED WATER

## ORIFICE METERS

SLIP-ON TYPE ORIFICE FLANGES - STRAIGHT  
PIPE: 30 DIAM. UPSTREAM, 3 DIAM. DOWNSTREAM

CHILLED WATER - 1.72 G.P.M./TON (40° TO 54°)

PIPE SIZE	TONS	LOSS PER 100 FT.	G.P.M.	UPSTREAM FT. REQ'D * (A) MIN.	DOWNSTREAM FT. REQ'D * (B) MIN.	RETURN FT. REQ'D * (C)
3"	35	1.74	60	9'	1'	3'
3"	81	8.32	140	9'	1'	3'
4"	87	2.53	150	10'	2'	3'-6"
4"	163	8.00	280	10'	2'	3'-6"
6"	174	1.24	300	15'	2'	4'
6"	494	8.50	850	15'	2'	4'
8"	521	2.48	900	20'	3'	4'-6"
8"	930	7.20	1600	20'	3'	4'-6"
10"	990	2.69	1700	25'	3'	4'-8"
10"	1860	8.58	3200	25'	3'	4'-8"
12"	2030	4.21	3500	30'	4'	5'
12"	2900	8.15	5000	30'	4'	5'
14"	2900	5.03	5000	35'	4'	6'
14"	4060	9.38	7000	35'	4'	6'

\* See piping illustrations on following drawings:  
Sketch #1013-3.

REVISED: 5-31-72  
REVISED: 7-15-70

<b>SKETCH #1013-4</b>
PREPARED BY:
<b>CARNAHAN &amp; THOMPSON</b>
<b>ENGINEERS</b>
OCTOBER 14, 1969



# METERING ENCLOSURE STEAM AND CHILLED WATER

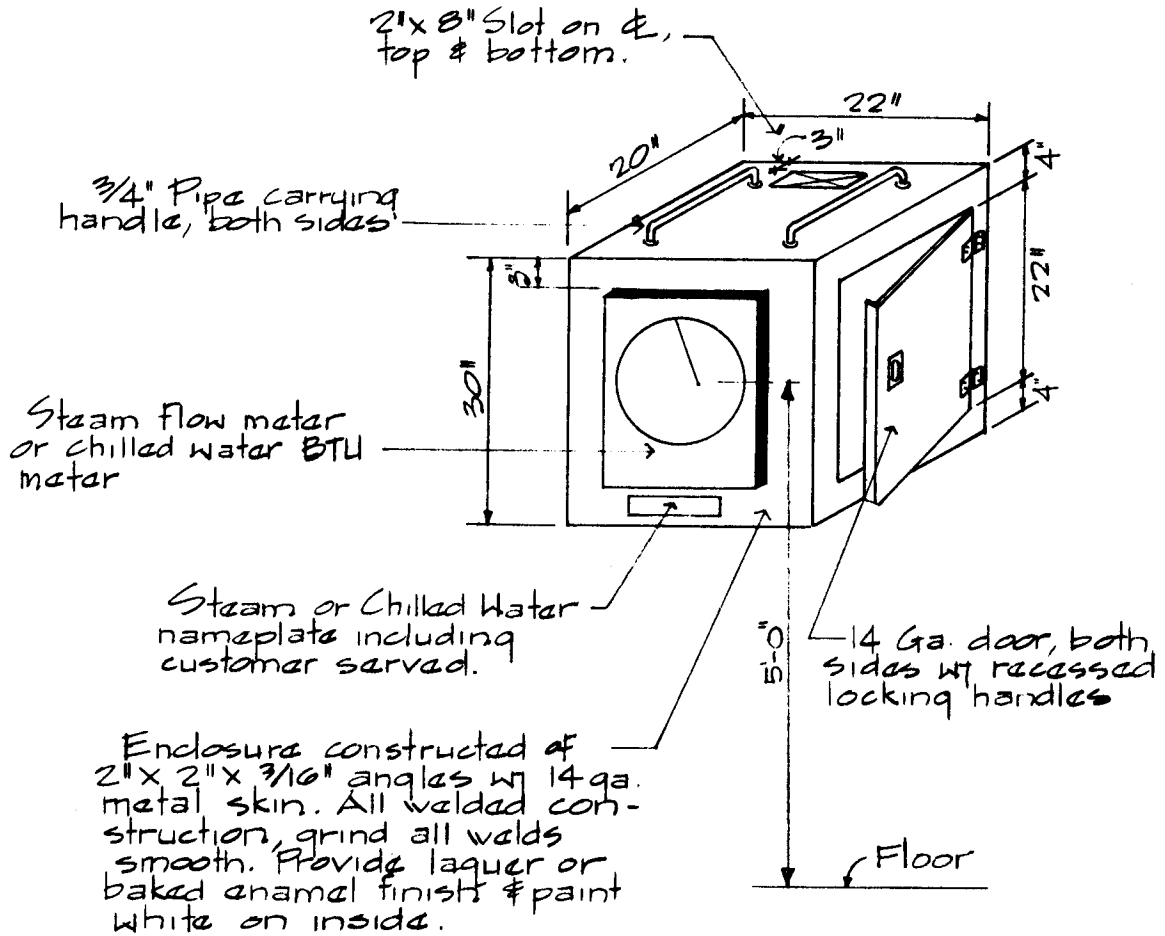

## NOTES:

1. Use seven (7) day charts
2. Meters shall have locking glass door.
3. Enclosures shall be located within customers building or in tunnel.

REVISED: 7-13-70  
5-31-72

<p><u>SKETCH No 1013-5</u></p> <p>PREPARED BY</p> <p><u>CARNAHAN &amp; THOMPSON</u></p> <p><u>ENGINEERS</u></p> <p>OCTOBER 14, 1969</p>
---

Exhibit E

REGENTS OF THE UNIVERSITY OF OKLAHOMA

CONTROL SERVICE AGREEMENT

THIS AGREEMENT made and entered into this \_\_\_\_ day of \_\_\_\_\_, 1973, by and between REGENTS OF THE UNIVERSITY OF OKLAHOMA hereinafter referred to as "SELLER," and \_\_\_\_\_, hereinafter referred to as "CUSTOMER."

WHEREAS, SELLER privately owns, maintains, and operates facilities in Oklahoma City capable of providing an automation service whereby SELLER can remotely monitor and operate certain mechanical and electrical equipment used for the air-conditioning, heating, and other systems of buildings; and

WHEREAS, CUSTOMER is the Owner of a building known as hereinafter referred to as "the Premises," and desires to purchase such automation service for said building;

WHEREAS, SELLER is willing to sell such automation service to CUSTOMER for the purpose and under the conditions set forth herein.

NOW, THEREFORE, the above premises considered, and in consideration of the mutual covenants and agreements herein contained, the parties agree as follows:

ARTICLE I - SERVICE

1.1 General. SELLER agrees to furnish an automation service, hereinafter referred to as "the Service," which will remotely monitor and operate CUSTOMER's equipment and system for air-conditioning and heating the Premises. SELLER's system for providing the Service shall have the capability of performing the following individual functions at the Control Center:

- a. Continuous scanning of connected points.
- b. Digital indication of individual point values (not point

identification only), such indication to be continually "updated" to show changing remote values.

- c. Digital logging.
- d. Alarming of off-normal conditions.
- e. Change-of-state digital logging in systems format with off-normal points in red and alphanumeric identification of all points.
- f. Remote motor manual start-stop.
- g. Remote motor programmed start-stop.
- h. Remote readjustments of controllers.
- i. Voice communication between Control Center and equipment rooms in CUSTOMER's building.
- j. Status indication of points.
- k. Logging of status.
- l. Trend logging of selected points.

1.2 Service to be Provided CUSTOMER. SELLER shall furnish the following Service to CUSTOMER hereunder:

a. Start and stop the equipment designated as equipment to be started and stopped in Exhibit B, attached hereto and by reference made a part hereof, in accordance with a schedule to be furnished by CUSTOMER to SELLER as provided below.

b. Monitor alarms on equipment as designated in Exhibit B attached hereto. SELLER's operator shall use reasonable diligence to notify CUSTOMER's designated representative of such alarm by means of the intercom stations located in equipment rooms or such locations on the Premises as designated by Exhibit B attached hereto or, in the event operator is unable by means of the intercom stations to contact said representative, by telephone. SELLER shall provide CUSTOMER with a list of all alarms received at the Control Center, as hereinafter defined, during each weekly period.

c. Advise CUSTOMER's designated representative daily, to

the extent provided for in Exhibit B, of (1) those filters, if any, which require attention and (2) those air and water temperatures and other sensed variables, if any, as required.

d. CUSTOMER shall act reasonable in requesting information, logs, resets, or other control center data or functions, such requests being limited to those necessary to properly supervise and operate the related equipment in the Premises.

e. Exhibit B, attached hereto, contains a schedule of the points of service and the service function (start-stop, alarm, temperature, etc.) which will be furnished at each such point under this Agreement and such other information as may be required by this Agreement.

1.3 Off-Normal Conditions. Upon the detection of an off-normal condition, SELLER shall do the following:

a. Take corrective action from the Control Center, as herein-after defined, at the central plant, if possible;

b. Notify CUSTOMER's designated representative or, if unavailable, CUSTOMER's on-duty maintenance personnel; and

c. If necessary, dispatch a representative to repair any equipment SELLER shall be required to maintain hereunder.

1.4 Additional Service. In addition to the Service which SELLER shall provide under Paragraph 1.2 above, SELLER shall provide CUSTOMER with a logging service which shall provide CUSTOMER with log sheets showing equipment status and the air and water temperatures of equipment shown on Exhibit B attached hereto. (A typical log sheet might (1) include any combination recording of outside air, mixed air, hot duct, cold duct, supply duct, hot water supply, hot water return, chilled water supply, and chilled water return temperatures for trend logging; (2) be all point logging; (3) be system logging; or (4) be off-normal logging.) Such logging service shall be provided on the following basis:

a. A maximum of 20 complete system logs shall be furnished as requested by CUSTOMER, during the period of initial start-up of CUSTOMER's heating and air-conditioning system if initial start-up is made after the Commencement of the service hereunder.

b. Change-of-state logs, i.e. the occurrence of any point changing from a normal to off-normal condition or the return of a point from off-normal to normal shall, with the printer enabled, cause a print-out. Such print-outs shall be provided to the CUSTOMER without limit as outlined in Paragraph 1.2b above, except where the CUSTOMER, through the performance of service, repair, or other routine on his equipment causes excessive and repetitive change-of-state logs and where information of such print-outs is agreed to be of no value.

c. Two (2) trend logs per week shall be furnished to CUSTOMER as requested by CUSTOMER at no additional charge, or in lieu of trend logs, CUSTOMER may substitute other logs at the following rate: one all-point log or one off-normal log for one trend log, or four system logs (maximum of six (6) systems per log) for one trend log. Unused logs may not be cumulated.

d. Additional logs regardless of type shall be furnished, at SELLER's option at a cost of Ten Dollars (\$10.00) per log, when requested by CUSTOMER.

Each trend log shall consist of a sequential recording of a maximum of any eight (8) points shown on Exhibit B at the selected interval for a continuous period of time not to exceed sixty (60) minutes. This trend logging shall not preclude the continuous scan of all points. The occurrence of any alarm or off-normal condition shall override this trend logging to locate and print-out the alarming system, such trend logging to resume immediately thereafter.

1.5 Schedule. CUSTOMER shall furnish a written schedule

showing the times when air handling units and pump units should be started and stopped during each calendar week. Such schedule shall be delivered to the plant supervisor not later than noon Thursday of the preceding week. Changes in such schedule shall be kept to a minimum. Further, SELLER shall start and stop air handling and pump units on a non-scheduled basis when requested by CUSTOMER. CUSTOMER shall keep such requests to a minimum. SELLER shall provide verbal temperature checks when requested by CUSTOMER; CUSTOMER shall act reasonable in requesting such checks.

## ARTICLE II - FACILITIES

2.1 SELLER's Facilities. SELLER's facilities include a JOHNSON Data Automation Center, herein referred to as "the Control Center," which is capable of performing the Service specified hereinabove. The Control Center is located at the Central Steam and Chilled Water Plant, 801 N. E. 8th, Oklahoma City, Oklahoma. SELLER shall arrange for a suitable communications link between the Control Center and the Premises and shall wire said communications link to the Control Center and the Customer Panel, as hereinafter defined.

2.2 CUSTOMER's Facilities. CUSTOMER shall supply and install on the Premises JOHNSON Data Collection (MPX) Panels, hereinafter referred to as "the Data Panels," in each equipment room or as necessary, as approved by SELLER. Further, CUSTOMER shall supply and install appropriate sensors, devices, instruments, appliances, alarms, intercom stations, and other components on the Premises, hereinafter referred to as "the Components," as are required to superimpose the Service on CUSTOMER's mechanical and electrical equipment and systems used to serve the Premises. The Components must be compatible with SELLER's equipment and facilities in SELLER's sole judgment. Further, CUSTOMER shall wire all the Components to their respective Data Panels and wire the Data Panels to terminal blocks in a panel located on the Premises at a

point reasonably near the point of ingress of SELLER's Control Cable to the Premises, herein referred to as the "the Customer Panel," in a manner approved by SELLER. As used hereinafter, the term "the Customer Components" shall include the Data Panels, the Components, the Customer Panel, the wiring, and all other equipment and facilities CUSTOMER is required to furnish hereunder.

2.3 SELLER's Approval of CUSTOMER's Facilities. At least \_\_\_\_\_ days prior to the COMMENCEMENT DATE, as hereinafter defined and required by Paragraph 5.1, CUSTOMER shall submit plans and specifications showing all Customer Components and related facilities, both existing or proposed, to SELLER for review to insure total system compatibility. CUSTOMER shall provide SELLER with two (2) complete sets of plans and specifications, including all addenda and change orders, if any, for SELLER's use in performing this contract. SELLER shall have thirty (30) days from the date such plans and specifications are furnished to review same to determine whether the system and equipment described therein are reasonably suitable for the purposes of this Agreement and to notify CUSTOMER of SELLER's determination relative thereto. In the event that SELLER determines that CUSTOMER's system and equipment, existing or proposed, are not reasonably suitable for the purposes of this Agreement, SELLER may require reasonable additions and modifications to CUSTOMER's system; such additions and modifications are to be specified by SELLER in said notice. Upon such notification, CUSTOMER shall make the necessary additions and modifications. Upon final approval and acceptance of CUSTOMER's plans and specifications by SELLER, SELLER shall promptly notify CUSTOMER thereof. Said plans and specifications as approved, or a suitable substitute thereof, labeled Appendix A and attached hereto, shall be initialed by a representative of each party. CUSTOMER warrants that the actual installation of its system shall substantially follow such plans and specifications, and any variance therefrom shall not materially

affect the operation of SELLER's automation system providing the Service.

2.4 Maintenance. After obtaining the approval of CUSTOMER's designated representative, SELLER shall perform preventive maintenance and routine service work during the normal working hours of SELLER's normal working days on the overall automation system, including Customer Components, and shall provide emergency service, including overtime service, as required to keep the overall automation system, including both SELLER or CUSTOMER portions of the system, in proper operation. Periodic maintenance inspection of SELLER and customer facilities on the Premises shall be rendered twice each year, in the fall and spring, the specific date for each such inspection to be approved by CUSTOMER's designated representative in advance of each such inspection. SELLER shall be free to start and stop all primary equipment related to the operation of the automation system, as arranged with CUSTOMER's designated representative. CUSTOMER shall provide reasonable access to both SELLER and CUSTOMER equipment and facilities on the Premises which are to be serviced by SELLER hereunder. After approval of CUSTOMER's designated representative, SELLER shall repair and replace Customer Components as necessary, in SELLER's judgment, for the proper functioning of the overall automation system, but shall not be responsible for the service, repair, or replacement of CUSTOMER's mechanical and electrical equipment and temperature control devices or for repairs necessitated by changes or additions to the wiring systems of CUSTOMER's building. CUSTOMER shall, within a reasonable period after notice from SELLER, effect reasonable repairs to its equipment or system, when, in the opinion of SELLER, necessary for the operation of the overall automation system. CUSTOMER shall reimburse SELLER for the cost of any repairs or replacement of Customer Components when such repair or replacement is necessitated by reason of negligence or misuse by CUSTOMER or by reason of any other cause beyond SELLER's control, except ordinary wear and tear. When it is determined by



SELLER's service man that a CUSTOMER request is for service to which CUSTOMER is not entitled under this Agreement, CUSTOMER shall be charged by SELLER for said service call at the prevailing rate of JOHNSON SERVICE COMPANY for like service. CUSTOMER, when notified of an alarm condition or off-normal condition, shall respond as expeditiously as possible and take such steps as are reasonably necessary to correct such condition.

2.5 Spare Parts. SELLER shall at all times maintain a sufficient supply of parts in Oklahoma City, Oklahoma, to provide for any repair or replacement necessary to keep the automation system operational with minimum down time.

2.6 Miscellaneous. CUSTOMER shall furnish necessary electric current, at CUSTOMER's sole expense, required for the operation of that portion of the overall automation system located on the Premises.

### ARTICLE III - LIABILITY

3.1 Interruption or Curtailment of Service. SELLER shall use reasonable diligence in providing the Service on a constant and uninterrupted, twenty-four (24) hour per day, seven (7) day per week, basis during the term hereof, but does not warrant or guarantee uninterrupted or uncurtailed Service and shall not be liable for any damages caused by or resulting from an interruption or curtailment of Service. In the event Service is interrupted as the result of fire, strike, riot, civil disturbance or commotion, explosion, flood, accident, breakdown, legal interference (including, but not necessarily limited to, loss of permit to use the public streets and alleys of the City of Oklahoma City, Oklahoma), acts of God, or the public enemy, or other acts or circumstances beyond the control of either party, affecting the Premises or equipment of CUSTOMER's or SELLER's system, payment for the Service shall be adjusted, based on a proration of the period and the degree

to which Service was suspended. In the event Service is otherwise interrupted for a period of time in excess of forty-eight (48) hours, and provided that CUSTOMER is capable of receiving the Service during such period of interruption of Service, and provided further that such interruption is not caused by CUSTOMER, payment for the Service shall be adjusted based on a proration of the period and the degree to which Service was suspended. Both parties shall be prompt and diligent in removing and overcoming the cause or causes of any interruption, and nothing contained herein shall be construed as permitting SELLER to refuse to furnish, or CUSTOMER to refuse to accept Service after the cause of interruption has been removed. Strikes or labor trouble shall be deemed beyond the reasonable control of the party claiming failure as a result thereof, and in the event of such strike or labor trouble, the obligation to be prompt and diligent in removing and overcoming the cause of interruption shall not be interpreted as requiring the making of any concession or conceding to any demands by such party during such strike or labor trouble. The refusal of CUSTOMER to accept the Service for any cause other than as stated in this Paragraph, or otherwise provided herein, shall not relieve CUSTOMER of its obligation to pay for the Service pursuant to the terms of this Agreement.

3.2 SELLER's Liability. SELLER shall not be responsible or liable for any loss, claim, or damage arising out of SELLER's failure to furnish the Service to the Premises, other than as provided in Paragraph 3.1 above; and CUSTOMER shall indemnify and hold SELLER, their trustees, officers, agents, and employees harmless in this regard. SELLER shall not be liable for any special, indirect, or consequential damages arising from the materials furnished, work performed, or services rendered as part of this Agreement.

#### ARTICLE IV - PAYMENT

4.1 General. Except for the additional service rendered under Paragraph 1.4 above, CUSTOMER agrees to pay, pursuant to the terms, covenants, and conditions hereof, commencing with the COMMENCEMENT DATE, as defined hereinafter, for the service rendered hereunder, a monthly payment in advance equal to the amount of the base charge specified in Section 1 of Exhibit A, attached hereto and by reference made a part hereof, adjusted in accordance with Section 2 of Exhibit A attached hereto. CUSTOMER agrees to pay monthly for the additional service furnished under Paragraph 1.4 above in accordance with the charge for such service specified therein. Payment is to be made by CUSTOMER by the 15th day of the month in which such payment is due.

4.2 Taxes. CUSTOMER shall pay all taxes, fees, and surcharges imposed, or which may be imposed, directly or indirectly upon the Service, such as but not necessarily limited to sales tax.

4.3 Billing and Payments. All billings hereunder shall be rendered to CUSTOMER by Regents of the University of Oklahoma and all payments made by CUSTOMER for such services shall be made to Regents of the University of Oklahoma at such address as SELLER shall specify. All charges for extra service furnished under this Agreement shall be individually itemized on the billing.

#### ARTICLE V - TERM, COMMENCEMENT, AND TERMINATION

5.1 Term and Commencement. Subject to the provisions of paragraphs 5.2 and 5.3, the Agreement shall extend from the COMMENCEMENT DATE, as defined hereinafter to the first 30th day of June following such date, and from year to year thereafter until one of the parties shall give to the other party at least three (3) months' notice in writing of its intention to terminate the Agreement at the end of the initial one-year term or any subsequent year thereafter. Automation service hereunder

shall commence on \_\_\_\_\_, 19\_\_\_\_, (or on an earlier date if SELLER and CUSTOMER so agree), hereinafter referred to as the "COMMENCEMENT DATE." SELLER shall use reasonable diligence to construct or expand its facilities, as necessary, to provide the Service by the COMMENCEMENT DATE to CUSTOMER, but shall not be responsible for failure to provide such Service upon the COMMENCEMENT DATE due to causes beyond its control.

5.2 Termination by SELLER. SELLER may cancel this Agreement at its option upon the happening of any of the following events:

- a. SELLER's equipment on the Premises is destroyed or substantially damaged by fire or other casualty;
- b. The Control Center or the Central Plant is destroyed or substantially damaged by fire or other casualty;
- c. There is a loss of the conduit and cable system furnishing the communications link between the Control Center and CUSTOMER's Premises or the destruction or substantial damage of such conduit system, cable system, or both; or
- d. CUSTOMER fails to pay in full, for a period in excess of forty-five (45) days after billing, the charges billed to it by SELLER for Services rendered under this Agreement or is otherwise guilty of substantial breach of any provision of the contract.

5.3 Termination by CUSTOMER. CUSTOMER may cancel this Agreement at its option upon the happening of any of the following events:

- a. The Premises are destroyed or substantially damaged by fire or other casualty.
- b. There is a loss of the conduit and cable system furnishing the communications link between the Control Center and CUSTOMER's Premises.
- c. SELLER is in default through failure to provide the Service to CUSTOMER as required by this Agreement and such

default is not corrected or remedied by SELLER within such period as reasonably may be required to correct or remedy such default with due diligence after CUSTOMER has notified SELLER in writing of such default.

5.4 Damages. In the event of cancellation as provided in Paragraphs 5.2 and 5.3 above, neither party shall be liable for damages or subject to penalty.

5.5 Removal of SELLER's Facilities. Upon cancellation or termination of this Agreement, or upon the default of CUSTOMER in payment of any monies due hereunder, SELLER may, at its option, remove, or abandon without removing, any and all of its equipment and facilities on the Premises. SELLER shall repair any damage caused to the Premises by such removal and shall restore all surfaces damaged by such removal to as close to its condition prior to such removal as shall be reasonably possible under the circumstances.

#### ARTICLE VI - SELLER'S FACILITIES ON PREMISES

6.1 Easements and Other Rights. CUSTOMER shall provide, without cost to SELLER, any easements or other rights necessary for the installation of SELLER's equipment and facilities on private property on which the Premises are located for the purpose of providing the Service to the Premises. Any easement or other necessary right furnished by CUSTOMER shall provide for a term of not less than the term of this Agreement, plus any renewals or extensions thereof, and shall further provide for SELLER's ingress and egress for maintenance, repair, replacement, or removal of SELLER's equipment and facilities.

6.2 All Equipment to Remain Property of SELLER. All equipment placed in or on the Premises by SELLER under the terms and conditions of this Agreement for the purpose of providing the Service hereunder, unless otherwise expressly provided, shall be and remain the property

of SELLER, and CUSTOMER shall exercise reasonable care to protect such property from loss or damage.

#### ARTICLE VII - MISCELLANEOUS

7.1 Insurance on Premises. CUSTOMER agrees to maintain its own fire and extended coverage insurance on the Premises and hereby waives all rights against SELLER for any loss to the Premises resulting from any of the perils insured against, regardless of their cause.

7.2 Insurance on SELLER's Components. SELLER agrees to maintain its own fire and extended coverage insurance on the SELLER's Components and hereby waives all rights against CUSTOMER for any loss to same resulting from the perils insured against, regardless of their cause.

7.3 SELLER's Liability Insurance Coverage. To the extent permitted by law, SELLER shall carry public liability insurance insuring SELLER against any and all legal liability for injury to persons (including wrongful death) and damage to property caused on the Premises by SELLER, its officers, agents and employees while on the Premises for the construction and installation of the SELLER's Components or the inspection, maintenance, repair, or operation of the SELLER's Components or the CUSTOMER's Components with liability limits of not less than \$10,000.00 for any person, and not less than \$50,000.00 for any accident involving injury (including wrongful death) to more than one person, and not less than \$10,000.00 for property damage resulting from one accident. SELLER shall furnish CUSTOMER with a certificate of such insurance prior to the Commencement Date which shall provide that said policy or policies will not be cancelled or materially modified, except upon ten (10) days advance written notice to CUSTOMER. SELLER shall carry insurance in such amounts as shall indemnify and save harmless CUSTOMER as required under said Paragraph 3.2. Further, SELLER shall comply with the Workmen's Compensation Laws of the State

of Oklahoma.

7.4 Obligations Upon Termination. Notwithstanding any other provision that may be contained herein to the contrary, the termination of this Agreement by either party as provided herein shall not relieve CUSTOMER of its obligation to pay any and all amounts due and owing to SELLER as of the date of such termination nor shall it relieve SELLER of its obligation to furnish Service to such date.

7.5 Notice. Notices required hereunder shall be in writing and shall be sent by registered or certified mail, addressed as follows:

"SELLER"	REGENTS OF THE UNIVERSITY OF OKLAHOMA Attention: Ms. Barbara James 660 Parrington Oval, #214 Norman, Oklahoma 73069
"CUSTOMER"	

7.6 Compliance With Statutes, etc. SELLER and CUSTOMER shall at all times comply with all appropriate Statutes, Ordinances, Code Regulations, or enactments of Public Bodies or Regulatory Agencies properly enacted, in the installation and operation of all equipment required hereunder, and all competent governmental regulatory authorities exercising jurisdiction over the subject matter hereof.

7.7 CUSTOMER's Designated Representative. Prior to the COMMENCEMENT DATE, CUSTOMER shall notify SELLER in writing of the name of the individual who is to act as CUSTOMER's designated representative for the purposes of this Agreement and shall notify SELLER in writing of any change therein.

7.8 No Oral Modifications. This Agreement may not be modified except by an instrument in writing signed by the parties hereto.

7.9 Use of Titles and Headings. The use of titles and headings for each Article and Paragraph herein shall in no way limit, extend, or impair the terms contained herein, the same being used for convenience

only.

7.10 Successors Bound and Assignment. This Agreement shall be binding upon and inure to the benefit of the successors and assigns of the parties. CUSTOMER may not assign this Agreement (in whole or in part) without the prior written consent of SELLER, which shall not be unreasonably withheld.

7.11 Special Terms and Conditions. Special terms and conditions, if any, are set forth in Exhibit C, which is incorporated herein and made a part of this Agreement.

IN WITNESS WHEREOF, the parties have signed this Agreement on the date hereinabove indicated.

REGENTS OF THE UNIVERSITY OF  
OKLAHOMA

By: \_\_\_\_\_

ATTEST:

\_\_\_\_\_

(SEAL)

\_\_\_\_\_

(CUSTOMER)

By: \_\_\_\_\_

ATTEST:

\_\_\_\_\_

(SEAL)



EXHIBIT A

SCHEDULE OF CHARGES AND ADJUSTMENTS

1. Base Charge. The base charge, hereinafter referred to as "the Base Charge", for the Service is \_\_\_\_\_ per month ( \_\_\_\_\_ ) per year.

2. Adjustments of Base Charge. The Base Charge may be adjusted for increases or decreases in SELLER'S costs, the amount of such adjustment to be determined as provided in Section 3 below. Adjustments shall take effect (30) days after written notice of such adjustment is sent to CUSTOMER or such later date as may be specified in such notice. Each such adjustment to the Base Charge made to reflect increases or decreases in SELLER'S cost shall remain in effect until such time as a new adjustment in the Base Charge is made hereunder. Failure of SELLER to promptly adjust the Base Charge within a reasonable period of time following the date of a change in the Wage Rate as hereinafter defined, shall not constitute a waiver of SELLER'S right to accumulate such changes and to take them into account on the date of a subsequent adjustment in the Base Charge.

3. Amount of Adjustment. When adjustment of the Base Charge is made under Section 2 above, the amount of such adjustment shall equal the percent (%) increase (or decrease) of the Wage Rate multiplied by the Base Charge. Wage Rates, as hereinafter defined, are for journeymen, plumbers and pipe fitters in the metropolitan Oklahoma City area as at the date written notice of an adjustment is sent to CUSTOMER, as provided for above, as determined from the applicable agreement between the association of Plumbing, Heating and Cooling Contractors and the United Association of Journeymen and Apprentices of the Plumbing and Pipe Fitting Industry of the United States and Canada, Locals #344 and 369, or their successors, hereinafter referred to as

the "Union Contract." A copy of the current Union Contract has been furnished to CUSTOMER, receipt of which is hereby acknowledged. The term "Wage Rates" as used herein includes the minimum Wage Rate and the fringe benefits and other compensation per hour for journeymen, plumbers and pipe fitters as specified in the applicable Union Contract.

4. Example of Adjustment in Base Charge. By way of hypothetical example, illustrating (but not limiting) the application of the method of adjustment described in Section 3 above, assume that the Wage Rates under the applicable Union Contract as of the date of this Agreement were \$7.00 and as of the date of the notice of adjustment to CUSTOMER were \$7.70, and that the base charge is \$1,000.00. The amount of the adjustment would be \$100.00, i.e. ( $\$7.70/\$7.00 \times \$1,000.00 = \$100.00$ .) The Base Charge as adjusted would be \$1,100.00, i.e. ( $\$1,000.00 + \$100.00 = \$1,100.00$ ).



EXHIBIT C

SPECIAL TERMS AND CONDITIONS

The following special terms and conditions are incorporated in  
and made a part of this Agreement: (If "none," so state.)

**(This page intentionally left blank)**

**carnahan-thompson-delano, inc.**  
professional consulting engineers-

(405) 528-5611

2 0 0 0 c l a s s e n c e n t e r

o k l a h o m a c i t y , o k l a h o m a 7 3 1 0 6

May 5, 1977

Exhibit G

The First National Bank & Trust Company  
Oklahoma City, Oklahoma 73102

Reference: University of Oklahoma  
Health Sciences Center  
Utility System Revenue Refunding Bonds, Series 1977

The Bond Resolution section 14-C, under the provision for "Additional Bonds", contains the following quoted provision:

"A Consulting Engineer shall certify to the Trustee Bank, with the approval of the Board of Regents, that the estimated net revenues to be derived from the then existing heating and cooling and the additional heating and cooling facilities to be constructed, shall, in the fiscal year following the date of the initial use of such heating and cooling facilities, be at least equal to the annual amount required for the payment of debt service requirements on all Bonds then outstanding and Bonds to be issued".

By application of a Base Rate Adjustment, the amount charged for services is adjusted each month so that the Revenue equals the operating, maintenance, and debt service cost. This procedure assures that the revenues to be produced by expanded facilities will continue to at least equal the annual amount required for the payment of debt service requirements on all Bonds. The application of the Base Rate Adjustment is agreed to in the Utilities Service Agreements in force with all users of the facility.

CARNAHAN-THOMPSON-DELANO, INC.

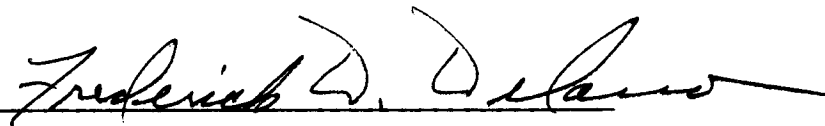
By 

Frederick D. Delano, P.E.

FDD/mfo

Exhibit HUNIVERSITY OF OKLAHOMA HEALTH SCIENCES CENTERYEAR ENDED JUNE 30, 1976I N D E X

	<u>Page</u>
Accountants' Report	1
Balance Sheet	2- 3
Statement of Changes in Fund Balances	4
Statement of Current Funds Revenues, Expenditures, and Other Changes	5
Notes to Financial Statements	6- 9
Additional Information:	
Accountants' Report	10
Steam and Chilled Water Plant:	
Balance Sheet	11
Statement of Changes in Fund Balances	12
Statement of Current Funds Revenues, Expenditures, and Other Changes	13
Cash Basis Financial Statements:	
Balance Sheet	14-15
Statement of Changes in Fund Balances	16
Statement of Current Funds Revenues, Expenditures, and Other Changes	17

TOUCHE ROSS & CO.

900 FIDELITY PLAZA  
OKLAHOMA CITY, OKLAHOMA 73102

August 31, 1976

Board of Regents  
University of Oklahoma  
Norman, Oklahoma

We have examined the balance sheet of The University of Oklahoma Health Sciences Center as of June 30, 1976, and the related statements of changes in fund balances and current funds revenues, expenditures, and other changes for the year then ended. Our examination was made in accordance with generally accepted auditing standards and accordingly included such tests of the accounting records and such other auditing procedures as we considered necessary in the circumstances, except as stated in the following paragraph.

As explained in Note A, the accounts receivable relating to the professional practice plan have not been recorded. The amount and collectibility are not determinable.

In our opinion, except for the effects on the financial statements of not recording the receivables in the current fund, the aforementioned financial statements present fairly the financial position of The University of Oklahoma Health Sciences Center at June 30, 1976, and the changes in fund balances and the current funds revenues, expenditures, and other changes for the year then ended, in conformity with generally accepted accounting principles applied on a basis consistent with that of the preceding year.

  
Certified Public Accountants



UNIVERSITY OF OKLAHOMA HEALTH SCIENCES CENTERBALANCE SHEET

JUNE 30, 1976

A S S E T S

CURRENT FUNDS:	
Unrestricted:	
Cash	\$ 2,728,010
Accounts receivable, less allowance for doubtful accounts of \$7,000 (Note A)	673,289
Due from current restricted funds	644,055
Other assets	48,500
Total Unrestricted	<u>4,093,854</u>
Restricted:	
Cash	752,702
Accounts receivable	376,298
Total Restricted	<u>1,129,000</u>
TOTAL CURRENT FUNDS	<u>\$ 5,222,854</u>
LOAN FUNDS:	
Cash	\$ 219,480
Notes receivable, less allowance for doubtful accounts of \$50,000 (Note A)	2,668,269
TOTAL LOAN FUNDS	<u>\$ 2,887,749</u>
PLANT FUNDS (Notes A, B, C, and D):	
Unexpended:	
Cash	\$ 5,846,031
Deferred charges	50,172
Total Unexpended	<u>5,896,203</u>
Retirement of Indebtedness:	
Deposits with trustees	1,833,089
Total Retirement of Indebtedness	<u>1,833,089</u>
Investment in Plant:	
Land	4,373,459
Buildings and improvements	36,308,721
Equipment	13,400,700
Construction in progress	6,909,495
	60,992,375
Less accumulated depreciation	(8,774,211)
Total Investment in Plant	<u>52,218,164</u>
TOTAL PLANT FUNDS	<u>\$59,947,456</u>

(Continued)

LIABILITIES AND FUND BALANCES

CURRENT FUNDS:	
Unrestricted:	
Accounts payable and accrued expenses	\$ 853,193
Loan payable - University of Oklahoma	47,500
Lease payable (Note B)	79,800
Fund balance	3,113,361
Commitments (Note E)	
Total Unrestricted	<u>4,093,854</u>
Restricted:	
Accounts payable and accrued expenses	391,007
Due to current unrestricted funds	644,055
Fund balance	93,938
Total Restricted	<u>1,129,000</u>
TOTAL CURRENT FUNDS	<u>\$ 5,222,854</u>
LOAN FUNDS:	
Fund balance (including amounts refundable on U. S. Government grants of \$2,115,616)	\$ 2,887,749
TOTAL LOAN FUNDS	<u>\$ 2,887,749</u>
PLANT FUNDS (Notes A, B, C, and D):	
Unexpended:	
Accounts payable	\$ 2,608,740
Bonds payable	1,199,325
Fund balance - unexpended	2,088,138
Total Unexpended	<u>5,896,203</u>
Retirement of Indebtedness:	
Fund balance - retirement of indebtedness	1,833,089
Total Retirement of Indebtedness	<u>1,833,089</u>
Investment in Plant:	
Bonds payable	15,110,675
Net investment in plant	37,107,489
Commitments	
Total Investment in Plant	<u>52,218,164</u>
TOTAL PLANT FUNDS	<u>\$59,947,456</u>

TOUCHE ROSS & CO.

UNIVERSITY OF OKLAHOMA HEALTH SCIENCES CENTER

BALANCE SHEET

JUNE 30, 1976

(Continued)

A S S E T S

AGENCY FUNDS:

Cash (Note F)

\$ 852,009

TOTAL AGENCY FUNDS

\$ 852,009

LIABILITIES AND FUND BALANCES

AGENCY FUNDS:

Accounts payable

\$ 91,081

Deposits held in custody for others (Note F)

760,928

TOTAL AGENCY FUNDS

\$ 852,009

See notes to financial statements.

## UNIVERSITY OF OKLAHOMA HEALTH SCIENCES CENTER

## STATEMENT OF CHANGES IN FUND BALANCES

YEAR ENDED JUNE 30, 1976

	Current Funds		Loan Funds	Plant Funds			Funds Held By Related Organization
	Unrestricted	Restricted		Unexpended	Retirement of Indebtedness	Investment In Plant	
REVENUES AND OTHER ADDITIONS:							
Unrestricted current funds revenues	\$ 29,304,859	\$ -	\$ -	\$ -	\$ -	\$ -	\$ -
State appropriations - restricted	-	526,777	-	3,691,544	-	-	-
Federal grants and contracts - restricted	-	5,882,632	175,365	5,005,799	-	-	-
Private gifts, grants, and contracts - restricted	-	1,121,610	6,081	-	-	-	-
Interest on loans receivable	-	-	47,405	-	-	-	-
Restricted auxiliary enterprise revenues	-	-	-	-	1,040,881	-	-
Expended for plant facilities (including \$1,189,386 charged to current funds expenditures)	-	-	-	-	-	11,974,928	-
Retirement of indebtedness	-	-	-	-	-	195,000	-
Other additions	-	-	2,935	261,462	130,838	-	210,804
Total Revenues and Other Additions	<u>29,304,859</u>	<u>7,531,019</u>	<u>231,786</u>	<u>8,958,805</u>	<u>1,171,719</u>	<u>12,169,928</u>	<u>210,804</u>
EXPENDITURES AND OTHER DEDUCTIONS:							
Educational and general	17,409,351	8,033,982	-	-	-	-	-
Auxiliary enterprises	4,377,144	-	-	-	-	-	-
Professional practice plan	6,263,467	-	-	-	-	-	-
Expended for plant facilities	-	-	-	10,785,542	-	-	-
Retirement of bond indebtedness	-	-	-	-	195,000	-	-
Interest on bond indebtedness	-	-	-	-	1,109,013	-	-
Disposal of plant facilities	-	-	-	-	-	100,641	-
Transfers to other state agencies	-	-	-	-	-	644,267	-
Depreciation	-	-	-	-	-	1,451,718	-
Other deductions	-	-	60,141	174,673	2,449	-	6,587
Total Expenditures and Other Deductions	<u>28,049,962</u>	<u>8,033,982</u>	<u>60,141</u>	<u>10,960,215</u>	<u>1,306,462</u>	<u>2,196,626</u>	<u>6,587</u>
TRANSFERS AMONG FUNDS - ADDITIONS (DEDUCTIONS):							
Nonmandatory:							
Transfer from related organization	66,812	-	-	-	-	217,043	(283,855)
Transfer of bond indebtedness from unexpended plant to investment in plant fund	-	-	-	3,118,654	-	(3,118,654)	-
Total Transfers	<u>66,812</u>	<u>-</u>	<u>-</u>	<u>3,118,654</u>	<u>-</u>	<u>(2,901,611)</u>	<u>(283,855)</u>
NET INCREASE (DECREASE) FOR YEAR	1,321,709	(502,963)	171,645	1,117,244	(134,743)	7,071,691	(79,638)
FUND BALANCE AT BEGINNING OF YEAR	<u>1,791,652</u>	<u>596,901</u>	<u>2,716,104</u>	<u>970,894</u>	<u>1,967,832</u>	<u>30,035,798</u>	<u>79,638</u>
FUND BALANCE AT END OF YEAR	<u>\$ 3,113,361</u>	<u>\$ 93,938</u>	<u>\$2,887,749</u>	<u>\$ 2,088,138</u>	<u>\$ 1,833,089</u>	<u>\$37,107,489</u>	<u>\$ -</u>

See notes to financial statements.

UNIVERSITY OF OKLAHOMA HEALTH SCIENCES CENTERSTATEMENT OF CURRENT FUNDS REVENUES,EXPENDITURES, AND OTHER CHANGESYEAR ENDED JUNE 30, 1976

	<u>Total</u>	<u>Unrestricted</u>	<u>Restricted</u>
<b>CURRENT FUNDS REVENUES:</b>			
Tuition and fees	\$ 1,018,530	\$ 1,018,530	\$ -
State appropriations	14,258,260	14,258,260	-
Federal grants and contracts	6,331,963	-	6,331,963
State and local grants and contracts	542,150	-	542,150
Private gifts, grants, and contracts	1,159,869	-	1,159,869
Sales and services of educational departments	567,155	567,155	-
Organized activities related to educational departments	2,075,474	2,075,474	-
Sales and services of the professional practice plan	6,780,160	6,780,160	-
Sales and services of auxiliary enterprises	4,605,280	4,605,280	-
Total Current Funds Revenues	<u>37,338,841</u>	<u>29,304,859</u>	<u>8,033,982</u>
<b>EXPENDITURES:</b>			
Educational and General (Note G):			
Instruction and departmental research	11,283,483	11,283,483	-
Research	2,517,603	139,898	2,377,705
Other sponsored programs	5,523,448	-	5,523,448
Extension and public service	33,191	33,191	-
Libraries	482,916	456,500	26,416
Operation and maintenance of plant	2,333,600	2,333,600	-
General administration	1,633,319	1,633,319	-
General institutional expense	1,408,865	1,408,865	-
Student aid	226,908	120,495	106,413
Total Educational and General Expenditures	25,443,333	17,409,351	8,033,982
Professional practice plan	6,263,467	6,263,467	-
Auxiliary enterprises	4,377,144	4,377,144	-
Total Expenditures	<u>36,083,944</u>	<u>28,049,962</u>	<u>8,033,982</u>
<b>OTHER TRANSFERS AND ADDITIONS (DEDUCTIONS):</b>			
Transfer from related organization	66,812	66,812	-
Excess of transfers to revenue over restricted receipts	<u>(502,963)</u>	<u>-</u>	<u>(502,963)</u>
<b>NET INCREASE (DECREASE) IN FUND BALANCES</b>	<u>\$ 818,746</u>	<u>\$ 1,321,709</u>	<u>\$ (502,963)</u>

See notes to financial statements.

UNIVERSITY OF OKLAHOMA HEALTH SCIENCES CENTER

NOTES TO FINANCIAL STATEMENTS

YEAR ENDED JUNE 30, 1976

A. Summary of Significant Accounting Policies:

(1) Organization -- The University of Oklahoma Health Sciences Center is an agency of the state of Oklahoma, under the control of the Board of Regents of The University of Oklahoma. It is located in Oklahoma City and includes colleges of medicine, health, dentistry, nursing, pharmacy, and graduate college.

(2) Basis of Accounting -- The statement of current funds revenues, expenditures, and other changes is a statement of the financial activities of current funds related to the current reporting period and does not purport to present the results of operations or the net income or loss for the period.

To the extent that current funds are used to finance plant assets, the amounts so provided are accounted for as: (1) expenditures, in the case of normal replacement of movable equipment and library books; (2) mandatory transfers, in the case of required provisions for debt retirement and interest; and (3) transfers of a nonmandatory nature in all other cases.

(3) Fund Accounting -- The financial statements are prepared in accordance with the principles of "fund accounting." This is the procedure by which resources for various purposes are classified for reporting purposes into funds that are in accordance with activities or objectives specified. Separate accounts are maintained for each fund; however, in the accompanying financial statements, funds that have similar characteristics have been combined into fund groups. Accordingly, all financial transactions have been reported by fund group.

Within each fund group, fund balances restricted by outside sources are so indicated and are distinguished from unrestricted funds allocated to specific purposes by action of the governing board or administration. Externally restricted funds may only be utilized in accordance with the purposes established by the source of such funds and are in contrast with unrestricted funds over which the governing board retains full control to use in achieving any of its institutional purposes.

All gains and losses arising from the sale, collection, or other disposition of noncash assets are accounted for in the fund which owns such assets. Income derived from investments, receivables, and the like is accounted for in the fund owning such assets.

UNIVERSITY OF OKLAHOMA HEALTH SCIENCES CENTER

NOTES TO FINANCIAL STATEMENTS

YEAR ENDED JUNE 30, 1976

(Continued)

Unrestricted revenue is accounted for in the unrestricted current funds. Restricted gifts, grants, appropriations, and other restricted resources are accounted for in the appropriate restricted fund. Restricted current funds are reported as revenues and expenditures when expended for current operating purposes.

- (4) Professional Practice Plan -- Professional personnel on the medical and health care staffs maintain practices whereby they bill patients for services rendered. The revenues for these services are to be transferred to the Health Sciences Center. The Health Sciences Center accounts for these revenues in the current unrestricted fund on a recorded cash receipt basis because the amount of gross revenues and the accounts receivable and their collectibility are not determinable.
- (5) Investment in Plant -- Land, buildings and improvements, equipment, and construction in progress are stated at cost at date of acquisition or fair market value at date of donation. Depreciation is computed by the straight-line method based upon the estimated useful lives of the related assets. Expenditures for maintenance and repairs are charged to expense as incurred whereas renewals and betterments are capitalized.
- (6) Employee Benefit Plans -- Substantially all of the academic and non-academic personnel of the Health Sciences Center are covered by various contributory and noncontributory retirement plans. The Center's policy is to fund pension cost accrued.

B. Lease Payable:

The lease covering property known as Moon Junior High School is considered to be equivalent to an installment purchase for purposes of accounting presentation. The cost of the property of \$133,000 is included in the investment in plant fund and the related lease obligation discounted at a 10% interest rate is set forth separately in the balance sheet.

Payments under the capitalized lease are \$35,000 per year through June 30, 1979.

C. Bonds Payable:

Bonds payable represent the Utility Series Revenue Bonds, Series 1973 and 1975, issued by the Board of Regents of The University of Oklahoma at interest ranging from 5 1/2% to 8%, payable July 1 and January 1. Annual bond maturities are as follows:

UNIVERSITY OF OKLAHOMA HEALTH SCIENCES CENTERNOTES TO FINANCIAL STATEMENTSYEAR ENDED JUNE 30, 1976

(Continued)

<u>Year Ending June 30,</u>	
1977	\$ 215,000
1978	225,000
1979	240,000
1980	260,000
1981	270,000
1982-1986	1,655,000
1987-1991	2,265,000
1992-2005	<u>11,180,000</u>
	<u>\$16,310,000</u>

The bond indentures require annual sinking fund payments of approximately \$1,200,000 to fund principal and interest payments throughout the term of the bond indentures and a sinking fund reserve of approximately \$1,500,000.

The University of Oklahoma Health Sciences Steam and Chilled Water Plant buildings and equipment with a carrying value of \$12,326,000 and the related revenues are collateral for the bonds payable.

D. Construction in Progress:

The institution has the following construction projects in process at June 30, 1976:

<u>Project</u>	<u>Construction in Progress</u>	<u>Remaining Commitment</u>
Steam and Chilled Water Plant	\$ 4,246,994	\$ 340,000
College of Nursing	2,222,476	1,412,000
Library Learning Resources	<u>440,025</u>	<u>5,426,000</u>
	<u>\$ 6,909,495</u>	<u>\$7,178,000</u>

E. Lease Commitments:

The aggregate rental commitment of the institution's Department of Dermatology, discounted to present value using a 7% interest rate, at June 30, 1976, under a noncancellable lease, is \$108,000 as follows:

UNIVERSITY OF OKLAHOMA HEALTH SCIENCES CENTERNOTES TO FINANCIAL STATEMENTSYEAR ENDED JUNE 30, 1976

(Continued)

<u>Year Ending</u> <u>June 30,</u>	
1977	\$ 17,800
1978	17,800
1979	17,800
1980	17,800
1981	17,800
1982-1985	<u>90,600</u>
	<u>\$179,600</u>

Substantially all rental agreements for use of buildings and equipment are on a one year renewable basis with the current year expenditure being approximately \$783,000.

F. Funds of the University Hospital and Clinics:

The center is acting in a custodial relationship for funds appropriated to The University of Oklahoma Board of Regents. The funds are to be utilized solely by the University Hospital and Clinics in its educational capital improvement program. The agency funds include \$655,563 of these funds at June 30, 1976.

G. Employee Benefit Plans:

The retirement benefit plans include the Oklahoma Teachers Retirement System, Teachers Insurance and Annuity Association, and College Retirement Equity Fund Retirement Addition. The Teachers Retirement System benefits are payable at retirement and are computed at the retirement date. The other plans are annuity types and benefits payable are determined at retirement.

Contributions to the retirement plans for the current year's funding was \$607,000. There are no past services costs in the employee benefit plans.



ADDITIONAL INFORMATION

In connection with our examination of the financial statements of The University of Oklahoma Health Sciences Center for the year ended June 30, 1976, we have also examined the additional information presented in the following pages.

In our opinion, the financial statements of the Steam and Chilled Water Plant are fairly presented in all material respects in relation to the financial statements taken as a whole, although they are not necessary for a fair presentation of financial position, the changes in fund balances, or the current funds revenues, expenditures, and other changes.

The cash basis financial statements are not fairly presented in accordance with generally accepted accounting principles, which require use of accrual basis of accounting.

*Touche Ross & Co.*  
Certified Public Accountants

UNIVERSITY OF OKLAHOMA HEALTH SCIENCES CENTERSTEAM AND CHILLED WATER PLANTBALANCE SHEETJUNE 30, 1976A S S E T S

CURRENT FUNDS:	
Unrestricted:	
Cash	\$ 148,788
Accounts receivable	239,518
Due from other Health Science Center departments	46,177
	<u>434,483</u>
TOTAL CURRENT FUNDS	<u>\$ 434,483</u>
PLANT FUNDS:	
Unexpended:	
Cash	\$ 1,750,208
Deferred charges	50,172
	<u>1,800,380</u>
Total Unexpended	<u>1,800,380</u>
Retirement of indebtedness:	
Deposits with trustees	<u>1,833,089</u>
Total Retirement of Indebtedness	<u>1,833,089</u>
Investment in plant:	
Buildings and improvements	7,400,426
Equipment	1,553,609
Construction in progress	4,246,994
	<u>13,201,029</u>
Less accumulated depreciation	(874,982)
Total Investment in Plant	<u>12,326,047</u>
TOTAL PLANT FUNDS	<u>\$15,959,516</u>

LIABILITIES AND FUND BALANCES

CURRENT FUNDS:	
Unrestricted:	
Accounts payable and accrued expenses	\$ 219,839
Fund balance	214,644
	<u>434,483</u>
TOTAL CURRENT FUNDS	<u>\$ 434,483</u>
PLANT FUNDS:	
Unexpended:	
Accounts payable	\$ 298,764
Bonds payable	1,199,325
Fund balance	302,291
	<u>1,800,380</u>
Total Unexpended	<u>1,800,380</u>
Retirement of indebtedness:	
Fund balance	<u>1,833,089</u>
Total Retirement of Indebtedness	<u>1,833,089</u>
Investment in plant:	
Bonds payable	15,110,675
Net investment in plant	(2,784,628)
	<u>12,326,047</u>
Total Investment in Plant	<u>12,326,047</u>
TOTAL PLANT FUNDS	<u>\$15,959,516</u>

UNIVERSITY OF OKLAHOMA HEALTH SCIENCES CENTERSTEAM AND CHILLED WATER PLANTSTATEMENT OF CHANGES IN FUND BALANCESYEAR ENDED JUNE 30, 1976

	Current Funds - Unrestricted	Unexpended	Plant Funds Retirement of Indebtedness	Investment In Plant
<b>REVENUES AND OTHER ADDITIONS:</b>				
Unrestricted current funds revenues	\$ 967,707	\$ -	\$ -	\$ -
Restricted auxiliary enterprise revenues	-	-	1,040,881	-
Retirement of bond indebtedness	-	-	-	195,000
Expended for plant facilities	-	-	-	3,112,862
Other additions	-	261,462	130,838	-
Total Revenues and Other Additions	<u>967,707</u>	<u>261,462</u>	<u>1,171,719</u>	<u>3,307,862</u>
<b>EXPENDITURES AND OTHER DEDUCTIONS:</b>				
Auxiliary enterprise expenditures	937,460	-	-	-
Retirement of bond indebtedness	-	-	195,000	-
Interest on bond indebtedness	-	-	1,109,013	-
Expended for plant facilities	-	3,112,862	-	-
Other deductions	-	7,650	2,449	-
Depreciation	-	-	-	257,419
Total Expenditures and Other Deductions	<u>937,460</u>	<u>3,120,512</u>	<u>1,306,462</u>	<u>257,419</u>
<b>TRANSFERS AMONG FUNDS - ADDITIONS (DEDUCTIONS):</b>				
Nonmandatory:				
Transfer of bond indebtedness	-	3,118,654	-	(3,118,654)
Total Transfers Among Funds	-	<u>3,118,654</u>	-	<u>(3,118,654)</u>
NET INCREASE (DECREASE) FOR THE YEAR	30,247	259,604	(134,743)	(68,211)
FUND BALANCE AT BEGINNING OF YEAR	<u>184,397</u>	<u>42,687</u>	<u>1,967,832</u>	<u>(2,716,417)</u>
FUND BALANCE AT END OF YEAR	<u>\$ 214,644</u>	<u>\$ 302,291</u>	<u>\$ 1,833,089</u>	<u>\$(2,784,628)</u>

UNIVERSITY OF OKLAHOMA HEALTH SCIENCES CENTER

STEAM AND CHILLED WATER PLANT

STATEMENT OF CURRENT FUNDS REVENUES,

EXPENDITURES, AND OTHER CHANGES

YEAR ENDED JUNE 30, 1976

REVENUES:

Sales and services of auxiliary enterprise (net of bond sinking fund requirements of \$1,040,881)	<u>\$967,707</u>
---	------------------

EXPENDITURES:

Auxiliary enterprise:

Salaries, fees, and wages	163,724
Supplies and materials	28,613
Utilities and communication	683,482
Staff benefits	11,189
Bond debt expense	5,991
Other	<u>44,461</u>

Total Expenditures	<u>937,460</u>
--------------------	----------------

EXCESS OF REVENUES OVER EXPENDITURES	<u>\$ 30,247</u>
--------------------------------------	------------------

TOUCHE ROSS & CO.

UNIVERSITY OF OKLAHOMA HEALTH SCIENCES CENTER

BALANCE SHEET

CASH BASIS

JUNE 30, 1976

A S S E T S

CURRENT FUNDS:	
Unrestricted:	
Cash	\$ 2,728,010
Other assets	48,500
Total Unrestricted	<u>2,776,510</u>
Restricted:	
Cash	752,702
Total Restricted	<u>752,702</u>
 TOTAL CURRENT FUNDS	 <u>\$ 3,529,212</u>
LOAN FUNDS:	
Cash	\$ 219,480
Notes receivable, less allowance for doubtful accounts of \$50,000	2,668,269
 TOTAL LOAN FUNDS	 <u>\$ 2,887,749</u>
PLANT FUNDS:	
Unexpended:	
Cash	\$ 5,846,031
Deferred charges	50,172
Total Unexpended	<u>5,896,203</u>
Retirement of indebtedness:	
Deposits with trustees	1,833,089
Total Retirement of Indebtedness	<u>1,833,089</u>
Investment in Plant:	
Land	4,373,459
Buildings and improvements	36,308,721
Equipment	13,065,516
Construction in progress	4,635,939
	58,383,635
Less accumulated depreciation	(8,774,211)
Total Investment in Plant	<u>49,609,424</u>
 TOTAL PLANT FUNDS	 <u>\$57,338,716</u>

LIABILITIES AND FUND BALANCES

CURRENT FUNDS:	
Unrestricted:	
Loan payable - University of Oklahoma	\$ 47,500
Fund balance	2,729,010
Total Unrestricted	<u>2,776,510</u>
Restricted:	
Fund balance	752,702
Total Restricted	<u>752,702</u>
 TOTAL CURRENT FUNDS	 <u>\$ 3,529,212</u>
LOAN FUNDS:	
Fund balance	\$ 2,887,749
 TOTAL LOAN FUNDS	 <u>\$ 2,887,749</u>
PLANT FUNDS:	
Unexpended:	
Bonds payable	\$ 1,199,325
Fund balance - unexpended	4,696,878
Total Unexpended	<u>5,896,203</u>
Retirement of indebtedness:	
Fund balance - retirement of indebtedness	1,833,089
Total Retirement of Indebtedness	<u>1,833,089</u>
Investment in Plant:	
Bonds payable	15,110,675
Net investment in Plant	34,498,749
 Total Investment in Plant	 <u>49,609,424</u>
 TOTAL PLANT FUNDS	 <u>\$57,338,716</u>

(Continued)

TOUCHE ROSS & CO.

UNIVERSITY OF OKLAHOMA HEALTH SCIENCES CENTER

BALANCE SHEET

CASH BASIS

JUNE 30, 1976

(Continued)

A S S E T S

AGENCY FUNDS:

Cash

\$ 852,009

TOTAL AGENCY FUNDS

\$ 852,009

LIABILITIES AND FUND BALANCES

AGENCY FUNDS:

Deposits held in custody for others

\$ 852,009

TOTAL AGENCY FUNDS

\$ 852,009

## UNIVERSITY OF OKLAHOMA HEALTH SCIENCES CENTER

## STATEMENT OF CHANGES IN FUND BALANCES

## CASH BASIS

YEAR ENDED JUNE 30, 1976

	Current Funds		Loan Funds	Plant Funds			Funds Held By Related Organization
	Unrestricted	Restricted		Unexpended	Retirement of Indebtedness	Investment In Plant	
REVENUES AND OTHER ADDITIONS:							
Unrestricted current funds revenues	\$ 28,914,967	\$ -	\$ -	\$ -	\$ -	\$ -	\$ -
State appropriations - restricted	-	526,777	-	3,691,544	-	-	-
Federal grants and contracts - restricted	-	5,506,333	175,365	5,005,799	-	-	-
Private gifts, grants, and contracts - restricted	-	1,121,610	6,081	261,462	-	-	-
Interest on loans receivable	-	-	47,405	-	-	-	-
Restricted auxiliary enterprise revenues	-	-	-	-	1,040,881	-	-
Expended for plant facilities (including \$1,181,552 charged to current funds expenditures)	-	-	-	-	-	11,583,139	-
Retirement of indebtedness	-	-	-	-	-	195,000	-
Other additions	-	-	2,935	-	130,837	-	210,804
Total Revenues and Other Additions	<u>28,914,967</u>	<u>7,154,720</u>	<u>231,786</u>	<u>8,958,805</u>	<u>1,171,718</u>	<u>11,778,139</u>	<u>210,804</u>
EXPENDITURES AND OTHER DEDUCTIONS:							
Educational and general	17,241,299	7,719,610	-	-	-	-	-
Auxiliary enterprises	4,460,520	-	-	-	-	-	-
Professional practice plan	6,766,767	-	-	-	-	-	-
Expended for plant facilities	-	-	-	10,401,587	-	-	-
Retirement of bond indebtedness	-	-	-	-	195,000	-	-
Interest on bond indebtedness	-	-	-	-	1,421,950	-	-
Disposal of plant facilities	-	-	-	-	-	100,641	-
Transfers to other state agencies	-	-	-	-	-	644,267	-
Depreciation	-	-	-	-	-	1,451,718	-
Other deductions	-	-	60,141	166,840	2,449	-	6,587
Total Expenditures and Other Deductions	<u>28,468,586</u>	<u>7,719,610</u>	<u>60,141</u>	<u>10,568,427</u>	<u>1,619,399</u>	<u>2,196,626</u>	<u>6,587</u>
TRANSFERS AMONG FUNDS - ADDITIONS (DEDUCTIONS):							
Nonmandatory:							
Transfer from related organization	66,812	-	-	-	-	217,043	(283,855)
Transfer of bond indebtedness from unexpended plant to investment in plant fund	-	-	-	3,118,654	-	(3,118,654)	-
Total Transfers	<u>66,812</u>	<u>-</u>	<u>-</u>	<u>3,118,654</u>	<u>-</u>	<u>(2,901,611)</u>	<u>(283,855)</u>
NET INCREASE (DECREASE) FOR YEAR	513,193	(564,890)	171,645	1,509,032	(447,681)	6,679,902	(79,638)
FUND BALANCE AT BEGINNING OF YEAR	<u>2,215,817</u>	<u>1,317,592</u>	<u>2,716,104</u>	<u>3,187,846</u>	<u>2,280,770</u>	<u>27,818,847</u>	<u>79,638</u>
FUND BALANCE AT END OF YEAR	<u>\$ 2,729,010</u>	<u>\$ 752,702</u>	<u>\$2,887,749</u>	<u>\$ 4,696,878</u>	<u>\$ 1,833,089</u>	<u>\$34,498,749</u>	<u>\$ -</u>

UNIVERSITY OF OKLAHOMA HEALTH SCIENCES CENTERSTATEMENT OF CURRENT FUNDS REVENUES,EXPENDITURES, AND OTHER CHANGESCASH BASISYEAR ENDED JUNE 30, 1976

	<u>Total</u>	<u>Unrestricted</u>	<u>Restricted</u>
<b>CURRENT FUNDS REVENUES:</b>			
Tuition and fees	\$ 1,017,644	\$ 1,017,644	\$ -
State appropriations	14,258,260	14,258,260	-
Federal grants and contracts	6,071,224	-	6,071,224
State and local grants and contracts	526,777	-	526,777
Private gifts, grants, and contracts	1,121,609	-	1,121,609
Sales and services of educational departments	567,155	567,155	-
Organized activities related to educational departments	1,773,925	1,773,925	-
Sales and services of the professional practice plan	6,780,160	6,780,160	-
Sales and services of auxiliary enterprises	4,517,823	4,517,823	-
Total Current Funds Revenues	<u>36,634,577</u>	<u>28,914,967</u>	<u>7,719,610</u>
<b>EXPENDITURES:</b>			
Educational and General:			
Instruction and departmental research	11,186,391	11,186,391	-
Sponsored research	2,341,415	132,423	2,208,992
Other sponsored programs	5,377,789	-	5,377,789
Extension and public service	32,562	32,562	-
Libraries	481,230	454,814	26,416
Operation and maintenance of plant	2,383,804	2,383,804	-
General administration	1,629,143	1,629,143	-
General institutional expense	1,301,666	1,301,666	-
Student aid	226,909	120,496	106,413
Total Educational and General Expenditures	24,960,909	17,241,299	7,719,610
Professional practice plan	6,766,767	6,766,767	-
Auxiliary enterprises	4,460,520	4,460,520	-
Total Expenditures	<u>36,188,196</u>	<u>28,468,586</u>	<u>7,719,610</u>
<b>OTHER TRANSFERS AND ADDITIONS (DEDUCTIONS):</b>			
Transfer from related organization	66,812	66,812	-
Excess of transfers to revenue over restricted receipts	<u>(564,890)</u>	<u>-</u>	<u>(564,890)</u>
<b>NET INCREASE (DECREASE) IN FUND BALANCES</b>	<u>\$ (51,697)</u>	<u>\$ 513,193</u>	<u>\$ (564,890)</u>



Exhibit I

UNIVERSITY OF OKLAHOMA - NORMAN CAMPUS AND HEALTH SCIENCES CENTER  
STATEMENT OF OUTSTANDING BONDS  
March 31, 1977

Bond Issue	Length of Issue	Bond Principal		Restricted Funds				Outstanding Less Total Restricted	
		Original Amount	Outstanding	Principal & Interest	Reserve	Repair & Replacement	Total		Percent Invested
<u>Student Housing Revenue Bonds:</u>									
1957 Bond System:									
Series A and B (1957)	40	\$ 6,541,000	\$ 1,505,000	\$ 446,704	\$ 764,136	\$ 31	\$ 1,210,871	79	\$ 294,129
Series C (OCCE 1959)	30	1,400,000	877,000	1,445	313,710	--	315,155	98	561,845
1963-64 Bond System:									
Series A and B (1963)	40	5,700,000	4,639,000	279,434	724,997	591,969	1,596,400	99	3,042,600
Series C (1964)	39	3,000,000	2,635,000	174,015	467,366	406,738	1,048,119	99	1,586,881
1966 Bond System	33	13,600,000	12,495,000	1,023,439	997,456	515,956	2,536,851	99	9,958,149
<u>Student Facilities Revenue Bonds:</u>									
Series D (1963)	15	1,800,000	375,000	6,491	327,267	--	333,758	98	41,242
Series A (1971)	15	1,760,000	1,330,000	11,252	273,102	77,692	362,046	99	967,954
Series B (1971)	25	4,000,000	4,000,000	37,600	454,934	65,719	558,253	99	3,441,747
<u>Oklahoma Memorial Union Bonds</u>	30	2,300,000	332,000	121,917	174,924	--	296,841	99	35,159
<u>Stadium System Revenue Bonds</u>	15	5,000,000	3,500,000	366,803	473,950	--	840,753	99	2,659,247
<u>Organized Group Housing:</u>									
Series 1 (PKP)	30	220,000	169,000	--	49,498	20,224	69,722	92	99,278
Series 2 (SAE)	30	<u>340,000</u>	<u>279,000</u>	<u>21,628</u>	<u>40,000</u>	<u>2,553</u>	<u>64,181</u>	91	<u>214,819</u>
TOTAL NORMAN CAMPUS		<u>\$45,661,000</u>	<u>\$32,136,000</u>	<u>\$2,490,728</u>	<u>\$5,061,340</u>	<u>\$1,680,882</u>	<u>\$ 9,232,950</u>		<u>\$22,903,050</u>
<u>Utility System Revenue Bonds:</u>									
Series 1973	30	\$10,125,000	\$ 9,735,000	\$ 283,362	\$ 997,810	\$ 100,000	\$ 1,381,172	99	\$ 8,353,828
Series 1975	30	<u>6,500,000</u>	<u>6,360,000</u>	<u>179,509</u>	<u>648,450</u>	<u>100,000</u>	<u>927,959</u>	99	<u>5,432,041</u>
TOTAL HEALTH SCIENCES CENTER		<u>\$16,625,000</u>	<u>\$16,095,000</u>	<u>\$ 462,871</u>	<u>\$1,646,260</u>	<u>\$ 200,000</u>	<u>\$ 2,309,131</u>		<u>\$13,785,869</u>
TOTAL BOTH CAMPUSES		<u>\$62,286,000</u>	<u>\$48,231,000</u>	<u>\$2,953,599</u>	<u>\$6,707,600</u>	<u>\$1,880,882</u>	<u>\$11,542,081</u>		<u>\$36,688,919</u>

Note: No accrued interest payable or receivable is included in the bonds outstanding and restricted funds totals.