

UNIVERSITY OF CENTRAL OKLAHOMA

Edmond, Oklahoma

Jackson College of Graduate Studies

Relocation of Remains: Scavenger Patterns in North Central Oklahoma

A THESIS

SUBMITTED TO THE GRADUATE FACULTY

In partial fulfillment of the requirements

For the degree of

MASTER OF SCIENCE IN FORENSIC SCIENCE

Kama A. King

University of Central Oklahoma

W. Roger Webb Forensic Science Institute

June 2014

# Relocation of Remains: Scavenger Patterns in North Central Oklahoma

Kama A. King

A THESIS

APPROVED FOR THE W. ROGER WEBB FORENSIC SCIENCE INSTITUTE

June 2014



---

Dr. Wayne Lord                      Committee Chair

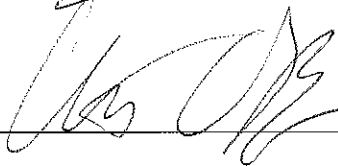

---

Dr. Christopher O'Brien      Committee Member

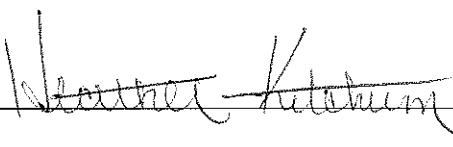

---

Dr. Heather Ketchum              Committee Member

## Abstract

The processes by which clandestine remains are scattered and destroyed by vertebrate necrophagus scavenging behaviors are significant to forensic death investigations, in terms of focusing search techniques, improving remains recovery, and contributing to more timely and successful case resolution. This research was derived directly from field work involving cases of scavenged remains where recovery was highly incomplete, leaving a question of whether search techniques were inadequate or if the remains had been destroyed and were simply irrecoverable. This study utilized domestic pig (*Sus scrofa*) carcasses placed at a wildlife conservation area during three different seasons, to assess members of the scavenger guild of the area, their associated behavior, and related effect on remains to address these issues. Carcasses were observed by digital video, motion triggered game cameras, and site visits. Biological radio telemetry transmitters, which are typically used to track living wildlife, were implanted in carcasses to assess long distance movement of skeletal elements. It was shown that there were three main participants in the vertebrate scavenger guild, the coyote (*Canis latrans*), the Virginia opossum (*Didelphis virginiana*), and the bobcat (*Lynx rufus*). Each of these species left unique taphonomic identifiers on the carcasses. They also contributed significantly to the destruction and dispersal of skeletal elements. There are clear patterns in time of carcass acquisition, tissues consumed by each species, and the subsequent dispersal of elements caused by each activity. Scavenging drastically increases time to skeletonization over comparable controls and highly effects estimations of post-deposition interval. Further research is needed to understand if these patterns are similar in human adult remains and other ecoregions.

## **Acknowledgements**

I would first like to thank my committee members, Dr. Wayne Lord, Dr. Christopher O'Brien, and Dr. Heather Ketchum, for their guidance and support of this research. I especially would like to thank Dr. O'Brien, who without which, funding for this project would not have been possible. He was also instrumental in the research design and implementation.

I must thank the University of Central Oklahoma, Office of Research and Grants, and the Forensic Science Foundation for financial support of this project.

I would also like to thank all of the faculty and staff at the Forensic Science Institute, the University of Central Oklahoma for their support in getting additional needed supplies which were not initially budgeted for as the project developed, and assisting in any issues that arose.

My sincere gratitude goes to the Oklahoma Department of Wildlife Conservation, especially officers Daniel Griffith and Damon Springer, for access to the research site. Without them this research would not have been possible.

Lastly, I thank my loving husband who has been supportive throughout both of my graduate school tenures. I would not have achieved any of this without him.

I dedicate this thesis to the memory of my mother Karla Sue Waggoner without whom I never would have discovered forensic science or the love of bones, and without whose support I never would have become the person that I am.

Table of Contents

i. SIGNATURE PAGE..... 1

ii. ABSTRACT..... 2

iii. ACKNOWLEDGEMENTS..... 3

1. CHAPTER 1: Introduction..... 5

2. CHAPTER 2: Methods and Materials..... 23

3. CHAPTER 3: Facultative Necrophagus Scavenging and Carrion Guild Participation  
by *Lynx rufus* in the Presence of Young..... 33

4. CHAPTER 4: The Virginia Opossum (*Didelphis virginiana*) and its Taphonomic  
Impact ..... 50

5. CHAPTER 5: The Relocation and Destruction of Remains as a Result of the  
Scavenging Behavior of *Canis latrans*..... 71

6. CHAPTER 6: Conclusions..... 96

REFERENCES..... 102

PHOTO APPENDIX..... 110

## **Chapter 1:**

### **Introduction**

## Introduction

One of the missions of biological based forensic science is to find and properly identify clandestine human remains. This serves not only the purposes of justice, but gives resolution and closure to family members. The recovery of human remains in forensic cases can be paramount to successful outcomes in those cases. In fact, the body may be the crucial piece of evidence in the successful prosecution of a homicide case. In both the American justice system and that of English common law it was held up until the late 1950s that a murder could not be proved without either the identification of found remains, direct testimony as to means of death, the admission of knowledge of the death, and/or a confession of guilt (Columbia Law Review, 1961). Homicide cases prosecuted without a body have been notoriously hard to win, being based solely on circumstantial evidence that must rule out all possibilities of innocence, although some cases have been successful, such as the precedent setting case *People v. Scott, 1959* (Columbia Law Review, 1961). Unfortunately, not all remains are reported or recovered close to the time of death or deposition. In some cases, remains may be undiscovered for months or even years (Delabarde & Ludes, 2010). In such instances, remains may be mostly skeletonized and dispersed making recovery of all of the elements more difficult, complicating searches and making those efforts less likely to be successful (Morton & Lord, 2006; Haglund & Reay, 1993).

Distances of separation of elements can be quite variable, anywhere from a few centimeters to hundreds of meters (Haglund & Reay, 1993). When movement of elements occurs, often only parts of the remains are recovered initially, presenting an array of investigative difficulties (Haglund & Reay, 1993). In a case from the Washington Olympic Peninsula, axial remains were discovered in 1969 while the cranium was not discovered until some 20 years later, in poor condition due to weathering and scavenging. Because of its poor condition the cranium was associated with previously recovered remains *only* by location of its discovery (Haglund &

Reay, 1993). This type of identification and association is highly problematic and unreliable. With the variables acting on remains' condition and location, it becomes essential that effective search and recovery methods are employed in order for remains to be completely collected and reliably identified, aiding investigators and increasing the likelihood of successful case outcomes.

The recovery of human skeletal remains in forensic cases affects successful outcomes in terms of determining time since deposition, cause of death, and identification of individuals (Menez, 2005). Identifying skeletal remains is more difficult than fresh bodies, which may retain clothing and other identifiers such as facial features, finger prints, and DNA. For example, a leg and foot found on the shore of Puget Sound were associated with the rest of the remains found in another location and identified simply by the presence of a matching black boot (Haglund & Reay, 1993). In contrast, in February of 1993 in the same region a partial mandible was found which could not be identified. Three years later, a cranium was found in close proximity to the location where the mandible was found and was confirmed to be from the same individual. However, lacking other diagnostic features, the individual was never identified (Haglund & Reay, 1993).

Lacking identifiers such as facial features and fingerprints, the determination of important factors like cause of death, identification of the individual, and other relevant biological information depend on the majority of the remains being recovered (White & Folkens, 2005; Steele & Bramblett, 1994; Ortner, 2003). Other important indicators such as defensive wounds, signs of long term abuse or acute injury, or indications of cause of death may also be lost (Ortner, 2003).



Complications in the collection of remains occur because of a wide array of variables which influence the rate and manner of decomposition (Haglund & Reay, 1993). Some of the main variables affecting this process include temperature, insect access, burial, and scavenging (Mann, Bass, & Meadows, 1990). All of these variables are region specific, and as such require region specific studies (Wiley & Snyder, 1989; Voss, Cook, & Dadour, 2011; Morton & Lord, 2006).

These variables can be defined in terms of taphonomic processes. Taphonomy, as described from archaeology, is most basically defined as “site formation processes”. These are all of the factors both natural and manmade that have combined to create the site or deposit artifacts. This framework is beneficial in the analysis of human remains deposition sites as they are formed by similar natural and manmade processes to those of ancient archaeological sites. The main difference between the two is length of time between creation and discovery. Many of these processes have been researched in depth in various fields and sub disciplines of forensic science and archaeology. The following is a discussion of these taphonomic variables and processes governing the formation of human remains’ deposition sites and influencing the condition of those remains.

### **Soft Tissue Decomposition**

Early investigations involving human decomposition relied on a combination of observations from case studies, laboratory studies, and professional experience. Mann, Bass, and Meadows (1990) utilizing these three data forms, created an assessment of variables such as temperature, insect activity, and other taphonomic processes, describing how they influence the decomposition process. They gave a broad overview of the decomposition sequence and rate,

consisting of descriptions of “a few days” or “a few months” and broad examples of other features (Mann, Bass, & Meadows, 1990). Similar observations have been made using case studies alone. Haglund, Reay, and Swindler (1989) described five broad stages of carnivore scavenging/disarticulation comparing them to broad stages of decomposition in non-scavenged remains. These observations are helpful in building the underlying knowledge base needed to accurately understand decomposition and taphonomic processes. However, more detailed analysis is necessary for accurate assessments of time since deposition, manner of death, and other crucial factors in forensic investigations.

The decomposition process is complicated and depends on a multitude of factors. This includes autolysis, which is the auto-digestion of tissue after death. This occurs in cells through internal chemical processes, and occurs in tissues due to enzymes released within the body following death. Decomposition is also affected by bacterial and fungal processes introduced from the intestines of the body and the surrounding environment (Campobasso, Di Vella, & Introna, 2001). After death, bodies can undergo several types of specialized decomposition: putrefaction, mummification, or saponification (Haglund, Reay, & Swindler, 1989). Putrefaction is when tissues become liquefied by the breakdown of proteins, carbohydrates, and lipids into their basic components of amino acids, water, carbon dioxide, and fatty acids. This process also produces gasses such as methane, ammonia, and hydrogen sulphide (Campobasso, Di Vella, & Introna, 2001). Mummification is essentially the opposite, where due to dry, hot, or windy environments the tissue rapidly dehydrates preventing bacterial proliferation and putrefaction thus preserving tissues (Campobasso, Di Vella, & Introna, 2001). Saponification differs from both of these processes, in that soft tissues and fat are converted to a grayish waxy substance, adipocere (Campobasso, Di Vella, & Introna, 2001). Adipocere is formed through the hydrolytic

decomposition of fats into fatty acids. These fatty acids then mix with ammonia and other elements released through decay processes to form soluble salts. These soluble salts then attach to metal elements such as magnesium within the body forming alkali salts and soaps which are mostly insoluble (Moses, 2012). This process occurs mostly in wet environments, but may occur under other conditions as well.

Each of these conditions differentially affects preservation of bone and pattern of dispersion. Which type of decomposition occurs is highly dependent on environmental factors, especially insect activity. Insects, such as blow flies (Diptera), can accelerate putrefaction and decomposition of soft tissue remains under certain conditions. Diptera larvae can consume the majority of soft tissues in as little as a few days in warmer temperatures (Campobasso, Di Vella, & Introna, 2001). The opposite is also true, in colder temperatures insect activity can be minimal, radically slowing the decomposition process (Rodriguez & Bass, 1982). The rate of these processes influences estimations of post deposition interval as well as condition of remains.

The significance of insect activity has been highly researched under controlled settings in a variety of environments (Campobasso, Di Vella, & Introna, 2001; Bass, 1997; Mann, Bass, & Meadows, 1990). Several authors have laid out general stages of decomposition, which are fresh, bloat, wet decay, advanced decay, and skeletonization (Campobasso, Di Vella, & Introna, 2001; Adlam & Simmons, 2007; MacAulay, Barr, & Strongman, 2009; Parks, 2011). Bachman and Simmons (2010) using these stages compared rabbit carcasses exposed pre-burial and unexposed immediately buried samples, examining the influence of pre-burial access of insects to the corpse on decomposition. They found that the 'fresh' stage of decomposition lasted approximately the same amount of time in both scenarios (Bachman & Simmons, 2010). Beyond this point though, the carcasses exposed pre-burial progressed much more rapidly through the other decomposition

phases than those buried immediately. In fact, they were skeletonized in approximately half the accumulated degree days (ADD), (which is a standardized measurement used to analyze decomposition rate adjusting for seasonality), as those buried immediately (Bachman & Simmons, 2010).

Similarly, research using rats in controlled laboratory experiments has shown that factors such as clothing, body position, and air exposure affect the rate of water transfer away from the body (Aturaliya & Lukasewycz, 1999). The rate at which water exits the body, mostly through the skin, affects the decomposition process and rate, in some instances leading to mummification of tissues, either locally or widespread. Clothing seems to speed up this process, creating a larger gradient between the internal and external water content of the body (Aturaliya & Lukasewycz, 1999). Water then transfers from the body to the environment through the process of osmosis. The greater the gradient, or difference in water saturation, the quicker this transfer occurs, which affects insect activity as well as other decomposition processes (Ibid.).

Research using closer human analogues, such as domestic pig (*Sus scrofa*) carcasses, has yielded surprisingly differing results. Voss, Cook, and Dadour (2011) assessed the difference in decomposition among clothed and unclothed carcasses. Their study was conducted in autumn 2001 in Western Australia and repeated in the same season in 2003. The average temperatures were fairly mild with an average in 2001 of 15.7 °C (60°F) and an average in 2003 17.4 °C (63°F). They found a difference in the time the clothed carcasses remained in wet decay, as well as increased insect activity, compared to unclothed carcasses. Unclothed carcasses were observed to be mostly skeletonized by the end of their 98 day study. The clothed carcasses however, were not in similar condition. Desiccated tissue remained beneath the clothing, still supporting insect activity at the completion of their study.

Knowledge about decomposition rates is essential not only to estimates of post deposition interval, but also to correctly identifying soft tissue injuries. For example, gunshot wounds can undergo many changes which may obscure them (MacAulay, Barr, & Strongman, 2009). The distance of the gun to the wound is a major factor in how long trace evidence will remain. Characteristics of distant shots, typically the most difficult to distinguish, have been observed to survive only through the bloat stage, and are obliterated soon after decomposition progresses into the next stage (MacAulay, Barr, & Strongman, 2009). Most gunshot wounds are evident only as long as skin is present, and are lost when the body enters advanced stages of decay (Ibid.).

While many decomposition and taphonomic studies have used animal analogues to investigate the decomposition process and influencing factors, a few studies address human decomposition directly using cadavers. Parks (2011) observed the decomposition sequence and rate of a cadaver exposed in a controlled area in central Texas. Results from studies such as this have shown a relatively high degree of variation in the time of the decomposition sequence, but not much variation in the sequence itself. This variation has been suggested to be a product of specific environmental conditions, leading researchers to suggest that similar studies be undertaken regionally (Morton & Lord, 2006; Reeves, 2009; Parks, 2011; Willey & Snyder, 1989). Besides being region specific, there are other limitations to the decomposition studies done to date. These studies tend to be conducted for only a few months and observations are typically concluded when soft tissue decomposition ceases.

### **Skeletal Decomposition and Taphonomy**

The cessation of soft tissue decomposition does not mark the end of the decomposition process. Similar processes as those which affect soft tissue continue acting on skeletal remains.

Changes to the skeletal structure in fact begin very shortly after death, in as little as three days (Bell, Skinner, & Jones, 1996). These changes take place at both a visible (Behrensmeier, 1978) and microscopic level (Bell, Skinner, & Jones, 1996). Factors such as weathering, soil corrosion, trampling, burning, and digestion by vertebrates induce changes to skeletal elements (Denys, 2002; Haglund, Reay, & Swindler, 1989; Olsen & Shipman, 1988).

Bones, like other tissues and organs in the body, are complex structures made up of cells. Skeletal tissue can be most simply classified into two main types: trabecular bone (also referred to as cancellous or spongy bone) and cortical bone (also referred to as compact bone) (Steele & Bramblett, 1994). Cortical bone forms the hard sturdy structures of the shafts of long bones and the thin outer layer of other bones. Cortical bone is hard and compact and is responsible for the rigidity of the weight bearing structures (Ortner, 2003). Trabecular bone is less dense and is found in the inner area of bones. It forms a matrix which allows for the transportation of blood and minerals, and creates the medullary cavity which contains bone marrow (Ortner, 2003).

Skeletal tissue is made up of 3 main types of cells: osteoblasts, osteocytes, and osteoclasts (Ortner, 2003; Steele & Bramblett, 1994). Osteoblasts are the producers of this group of cells, they are found in association with the periosteum and endosteum. They produce the protein matrix, osteoid, which becomes the hard mineralized layer of the bone (Steele & Bramblett, 1994). Osteoblasts are more prolific in young growing bone. Osteocytes then become embedded in the osteoid and become the bone maintaining cells (Ibid.). Osteocytes are found in oval cavities within the protein matrix created by the osteoblasts which are referred to as lacunae. These cells have fine cytoplasmic extensions that pass through small channels in the osteoid called canaliculi, which allow for the transfer of nutrients and other materials between the blood vessels and the bone cells. Osteocytes make up around 90% of mature bone (Ortner, 2003).

The third main type of bone cells are osteoclasts (Ortner, 2003; Steele & Bramblett, 1994). These cells are responsible for the destruction and remodeling of bone. Osteoclasts are much larger than the other types of bone cells, and are irregular in shape with more than one nucleus and a large number of lysosomes (Ortner, 2003). These cells are active throughout life and break down the outer surface of bone, which is then replaced by new osteoblasts and osteocytes. Bone is constantly renewing itself, albeit at a slower rate as life progresses, and like other tissues is constantly breaking down old tissue and replacing it with new tissue and minerals.

The natural process of skeletal mineral deposition, like other cellular processes, ceases when life ends. When this process stops no new minerals are added to the bone and those present begin to leach out into the surroundings. Through diagenesis, which is the chemical and physical change of sediments as they are converted into rock, essentially fossilization, the physical and elemental integrity of the bone is changed. This can be sped up by a variety of taphonomic and environmental influences including weather, temperature, or scavenging (Bell, Skinner, & Jones, 1996). Degradation of bone presents several problems. It makes bone more susceptible to postmortem breakage, can obscure antemortem and perimortem artifacts, as well as destroy valuable DNA.

These processes can obscure identity, as well as obscure cause of death, at both the soft tissue level (MacAulay, Barr, & Strongman, 2009; Asamura et al., 2004) and at the skeletal level (Calce & Rogers, 2007; Asamura et al., 2004). Several studies have examined post mortem changes to typical wounds found in homicide situations. Rain and snow have been shown to cause inward displacement of fractures from blunt force trauma, making them more difficult to discern (Calce & Rogers, 2007). In their experiments, Calce and Rogers (2007) showed that only

the outermost concentric fracture of an inflicted blunt force trauma wound to a pig cranium was left after 362 days of exposure. The rain and snow also created fractures originating at the sagittal and coronal sutures which were not present initially.

Breakage characteristics can be modified under certain conditions more than others. Bones frozen or exposed to cold temperatures degrade slower and exhibit fresh break characteristics much longer than bones exposed to a hot dry environment (Karr & Outram, 2012). Bones exposed to the latter conditions, degrade at a more rapid rate, and can in 1 to 3 days no longer exhibit fresh fracture characteristics (Ibid.). This is significant to forensic cases especially, as identifying trauma may be difficult or impossible in bones exposed to such conditions.

Weathering in general is a major force altering the consistency and appearance of bone (Behrensmeyer, 1978; Haglund, Reay, & Swindler, 1989). Weathering has been assessed in a variety of fields including archaeology, biology, and paleontology. This process does not act on all of the skeletal elements equally. The thickness of bone and the type of element have major bearing on the effects of weathering on the appearance and consistency of bone (Behrensmeyer, 1978; Denys, 2002). Weathering can cause cracking and flaking of exposed skeletal tissue (Behrensmeyer, 1978). It can also cause extensive color changes, typically bleaching (Huculak & Rogers, 2009). These changes can be quite destructive to perimortem injuries. However, the stage of weathering provides valuable time line information as to how long elements have remained exposed (Huculak & Rogers, 2009).

During soft tissue decomposition and following, skeletal elements may be scattered and removed from the initial deposition site. This can occur through a wide range of activities. The environment can play a heavy role in skeletal element movement. Cycles of freezing and



thawing may cause disarticulation, making elements susceptible to transport by water and simply gravity (Calce & Rogers, 2007; Haglund, Reay, & Swindler, 1989). Directionality and distance of movement are crucial considerations in collection strategies.

## **Scavenging**

Animal scavenging is one of the more common methods by which bones migrate (Kjorlien, Beattie, & Peterson, 2009; Stiner, Munro, & Sanz, 2011; Mann, Bass, & Meadows, 1990; Haglund & Reay, 1993; Haglund, Reay, & Swindler, 1989). Scavenging also introduces an array of damage to skeletal elements, which can disguise valuable diagnostic information (Asamura et al., 2004). Similar to the process of decomposition itself, scavenger activity can obscure or even obliterate evidence of gunshots, blunt force trauma, or other wounds. It is hypothesized that scavengers will target these areas first, being drawn by the presence of blood (Willey & Snyder, 1989). Carnivore activity can also cause extensive fractures and crushing of bone (Stiner, Munro, & Sanz, 2011), which can likewise obscure or obliterate distinguishing features.

Large carnivores may digest bone causing etching, corrosion, and polishing (Denys, 2002; Stiner, Munro, & Sanz, 2011), as well as complete destruction of the element, making them completely unidentifiable (Pickering, 2001). Some scavengers target specific elements, of which some are more susceptible to destruction than others, such as the crania. In contrast, other elements such as phalanges, metacarpals, and metatarsals tend to sustain less damage, as they are typically digested whole (Pickering, 2001). These elements may make it through the scavenger digestive track mostly intact, sometimes even retaining tissue such as skin and nails (Ibid.).

The type and extent of damage inflicted by scavenging activity varies by species of scavenger. Large carnivores can cause much more extensive damage than small vertebrates. Domestic dogs (*Canis sp.*) have been shown to be able to mostly destroy a corpse in as little as a few days in indoor settings (Steadman & Worne, 2007; Haglund, Reay, & Swindler, 1988). This process is similar in the wild but can take considerably longer (Steadman & Worne, 2007). The destruction by carnivores can be minimal to extensive. Carnivores tend to leave 'V' shaped scratches and linear abrasions from holding down elements with claws, as well as bite marks beyond the consumed margins due to their ripping and tearing action (Haglund, Reay, & Swindler, 1988). They also leave pits, punctures and furrows on the bone (Patel & Path, 1994). As stated before, they may even crush bone or cause extensive fracturing.

Avian scavengers such as vultures can be highly active at a carcass and have been shown to be capable of completely skeletonizing carcasses in as little as 24 hours (Reeves, 2009). Unlike canid activity, avian activity from species such as vultures causes less destruction to the elements over all. Avian scavenging tends to leave two types of defects: relatively shallow scratches and linear surface scratches lacking depth. Both of these artifacts have been attributed to the beaks of the birds (Reeves, 2009).

Similarly, rodents can introduce significant damage to the surfaces of bones, as they tend to feed on the outer surfaces, such as the periosteum, leaving channels, striae, and grooves on the surface of the bone (Haglund, 1992). This damage can obscure important indicators for forensic investigations such as defensive wounds.

## Scavenger Behavior

Scavenger behavior is driven by several biological imperatives and opportunity. Temperature and seasonality heavily influence both aspects of this equation. Temperature has been identified in several studies as affecting scavenger behavior (DeVault, Brisbin, & Rhodes, 2004; O'Brien et al., 2007; 2010; Selva et al., 2005). In moderately warm climates with ample food sources, vertebrates may not feed on carcasses at all (DeVault, Brisbin, & Rhodes, 2004). In contrast, in cold weather scavenging activity may increase because of the lack of food resources (Selva et al., 2005; DeVault, Brisbin, & Rhodes, 2004). Likewise, scavenging intensity in spring months may increase, which has been hypothesized to be a result of increased protein needs due to breeding (O'Brien et al., 2010).

Different vertebrates also follow different patterns based on temperature, such as reptiles, which are mostly inactive in cold conditions, but which feed readily on available carcasses under warmer conditions (DeVault, Brisbin, & Rhodes, 2004; O'Brien et al., 2007). Under conditions of extreme heat, scavenging activity can come to almost a halt, as vertebrates conserve energy and avoid the extreme heat (O'Brien et al., 2007; 2010).

Temperature may also influence scavenger behavior through preservation of remains. For example, the preservation of fats and bone marrow also varies between different environments, (Karr & Outram, 2012). In cold environments, marrow and bone fats are preserved and have been shown to still appear edible after as long as a year. In contrast, marrow in the high heat situations has been shown to remain edible for only a few days (Karr & Outram, 2012). This difference in preservation of edible marrow likely influences scavenger behavior. It has been shown that many large scavengers, such as *Canis sp.* and *Felis sp.*, as well as some rodents, such as brown rats, preferentially target bones rich in marrow (Klippel & Synsteliën, 2007; Haglund,

Reay, & Swindler, 1988). Long bone epiphyses and other areas of cancellous bone are often highly degraded by scavenger activity (Ibid.).

Similarly, condition of the carcass affects scavenging behavior (Selva et al., 2005). Certain birds such as crows have been observed to possibly prefer charred remains, while other scavengers avoid charred areas (Asamura et al., 2004; Gruenthal, Moffat, & Simmons, 2011). Carcasses buried in shallow graves (< 1' deep) have been shown to be preferred to those exposed, and are generally dug up by vertebrates. This is likely due to their lack of insect colonization (Morton & Lord, 2006). Buried carcasses which are dug up are also more likely to be moved greater distances and are less likely to be located (Ibid.). There has also been shown to be a strong aversion of scavengers to feed on diseased carcasses (Selva et al., 2005).

Not all species observed at a carcass are feeding directly on the remains. In several cases, avian scavengers and other omnivorous vertebrates may feed mainly on insects which have colonized the corpse (O'Brien et al., 2007; Gruenthal, Moffat, & Simmons, 2011). In fact, Mann, Bass, and Meadows (1990) stated that in their studies they have never observed birds feeding on the human body itself, but have observed birds feeding on maggots and carrion beetles.

### **Scavenger Dispersal**

Remains which are not scavenged typically remain in relative anatomical position, making recovery of most of the skeletal elements more likely (Haglund, Reay, & Swindler, 1989). Scavengers, however, can move elements a short distance from the body, or a surprisingly large distance away (Haglund & Reay, 1993). The type of scavengers present influences the distance which elements are scattered. Large vertebrates tend to cause more dispersion of elements than small vertebrate and avian scavengers. In instances where no large scavengers

were present, very few if any skeletal elements were moved from the scene (O'Brien et al., 2007). Some large vertebrates such as mountain lions tend to disarticulate and feed on elements at the carcass site (Stiner, Munro, & Sanz, 2011). Conversely, rodents and other small vertebrates have been shown to accumulate and haul away skeletal elements (Haglund 1992).

Dispersal patterns have been hypothesized to be driven on some level by population density and human activity (Haglund, Reay, & Swindler, 1989). It has been suggested that the movement of remains by scavengers tends to be in a direction away from human activity (Kjorlien, Beattie, & Peterson, 2009; Steadman & Worne, 2007). Similarly, more elements are recovered in areas closer to human activity, with the number of elements recovered decreasing as locations become more rural (Haglund, Reay, & Swindler, 1989). However, this pattern is not consistent over the course of previously conducted research. These patterns may be species specific. Some types of vertebrates have been shown to tend to avoid open areas, while others show the opposite pattern (Selva et al., 2005; Kjorlien, Beattie, & Peterson, 2009). Dispersal patterns may also simply be a product of scavengers taking 'the path of least resistance,' as skeletal elements are often found along highly utilized game trails.

## **Research Aims**

Building on the current knowledge base, this research project attempts to go beyond the current understanding that scavenging simply occurs and causes the scattering of remains, to understand the mechanisms by which this happens and the behavior that drives the scattering of remains in the attempt to quantify and document patterns in this behavior that are forensically significant. Understanding that remains are damaged and moved by scavenging activity is not enough, especially in terms of actually recovering remains. This project will document the

patterns of dispersal along with the amount and type of skeletal elements that remain recoverable over a longer time period than the majority of previous research. Many projects conclude once remains are skeletonized, this project attempts to go beyond this looking at the mechanisms that continue to act on the remains after soft tissue decomposition has ceased, which cause the scattering of skeletal elements that complicates search and recovery efforts. The following research questions will be addressed:

- What species are scavenging in Oklahoma?
- What distances do scavengers scatter elements?
- Is there directionality to the scatter of remains?
- What is the scatter pattern of remains?
- Are there seasonal patterns to scavenging activity?
- Can this dispersal pattern be used to create usable search patterns and criteria?

### **Significance to Forensic Science**

On average 10-20 sets of skeletal remains are recovered and assessed by the medical examiners' office each year in Oklahoma (A.K. Berg, OCME, Personal Communication). These are the forensic cases alone and not the total skeletal remains seen by the office. This is only a small percentage of the overall remains recovered in the state, but many of these remains are never identified, making them particularly challenging. Part of the reason is initial collection of the remains. Often very few elements, mainly larger bones, are recovered and taken to the medical examiner's office for analysis. As stated before, it is a necessity to have as much of the skeleton as possible in order to both identify the victim and determine cause of death. Most, if not all, of these remains are recovered from areas where scavenger activity is likely. Research

and case studies have found that a relatively large number of exposed corpses show evidence of scavenging (Haglund, Reay, & Swindler, 1989). Determining patterns of scavenger scatter and developing useful search parameters based on these patterns could potentially lead to more victims being recovered and identified.

Narrowing down the search area and providing more specific search instructions is critical, because in many instances these remains are not collected by trained professionals such as forensic archaeologists and/or forensic anthropologists. Random unaided searching can often lead to poor outcomes, lower morale, and sense of hopelessness among searchers which leads to premature ending of searches. Improving searching techniques will improve outcomes in all aspects of the search and identification process.

The pattern of movements of elements by taphonomic processes presents a possible key to creating successful search guidelines which eliminate many of the current pitfalls, like incomplete collection. The goals of this research are multi-tiered in order to fill several gaps in the forensic science literature. The main goal is to document scatter patterns of remains and distances elements are moved from the initial deposition site, which has been largely ignored in previous studies. The research will also collect data similar to what other studies have gathered, in order to assess species type, species frequency, species' habits, feeding time and sequence of decomposition, and allow comparability to previous research. As the need for region specific studies becomes more evident, studies which can improve estimates of post deposition interval and increase the recovery of remains become vital to individual regions. To date no such study has been done in the state of Oklahoma, which like most regions has unique climate and ecology. These types of studies are crucial in the recovery and analysis of skeletal remains and contribute vital information to the forensic sciences as a whole.

## **Chapter 2:**

### **Methods and Materials**



## Site Location

This experiment was conducted at the Oklahoma Department of Wildlife Conservation's, 5226.6 ha Arcadia Conservation Education Area, located along the southern shoreline of Lake Arcadia in north central Oklahoma (Figure 1). The lake was completed in 1987 by the Army Corp of Engineers by the damming of the Deep Fork River, for the purpose of flood control, wildlife habitat, and as a water reservoir for the city of Edmond, OK (Thomas & Walling, 2011). The area is a mix of riverine habitat, mixed grassland prairie, and cross-timbers. The cross-timbers eco-region covers large areas of central Oklahoma. It is comprised of mainly scrub oak forest interspersed with tall-grass prairie (Disney et al., 2008). This diverse landscape provides habitat for a wide variety of mammalian species including large predators and mesopredators, as well as small omnivores, and reptiles (Disney et al., 2008). Average rainfall for the area is 92 cm (Thomas & Walling, 2011). Public access is allowed to the area for hiking and fishing year round. Hunting access is limited to a small number of archery deer permits annually and no predator hunting or trapping is allowed, allowing for a robust predator population.

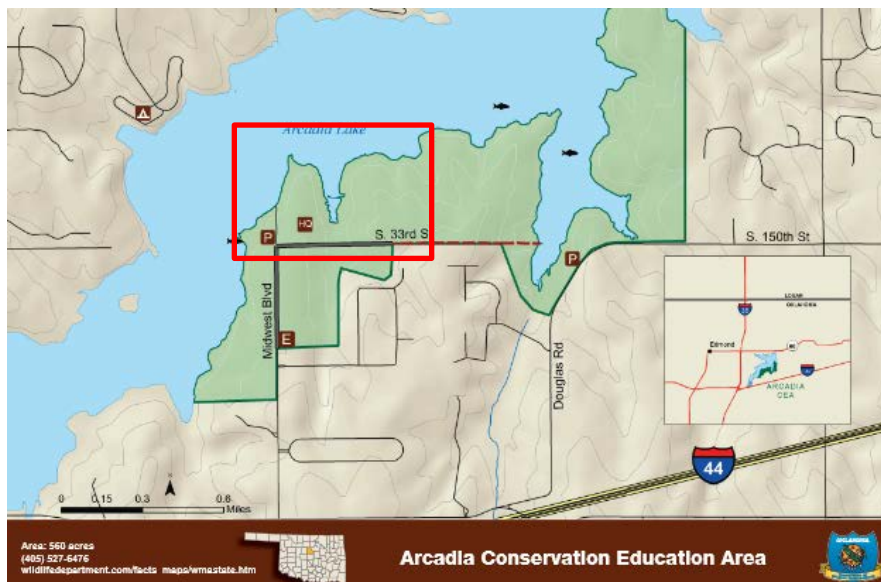

FIG.1 –Map of preserve boundaries and location, with experiment area in box, reprinted with permission from the Oklahoma Department of Wildlife Conservation

Three series of experiments were conducted from October 2012 through March 2014, when the last phase of the experiment was considered completed and final data were collected. Each carcass was given an identifying number for reference related to the experiment number, for example the first carcass placed in the first experiment is 1-1. The first two experiments of the series consisting of carcasses 1-1, 1-2, 1-3, 2-1, 2-2, and 2-3 were conducted in an area of the northwest portion of the preserve, between the lake and the permanent education building (Figure 2).

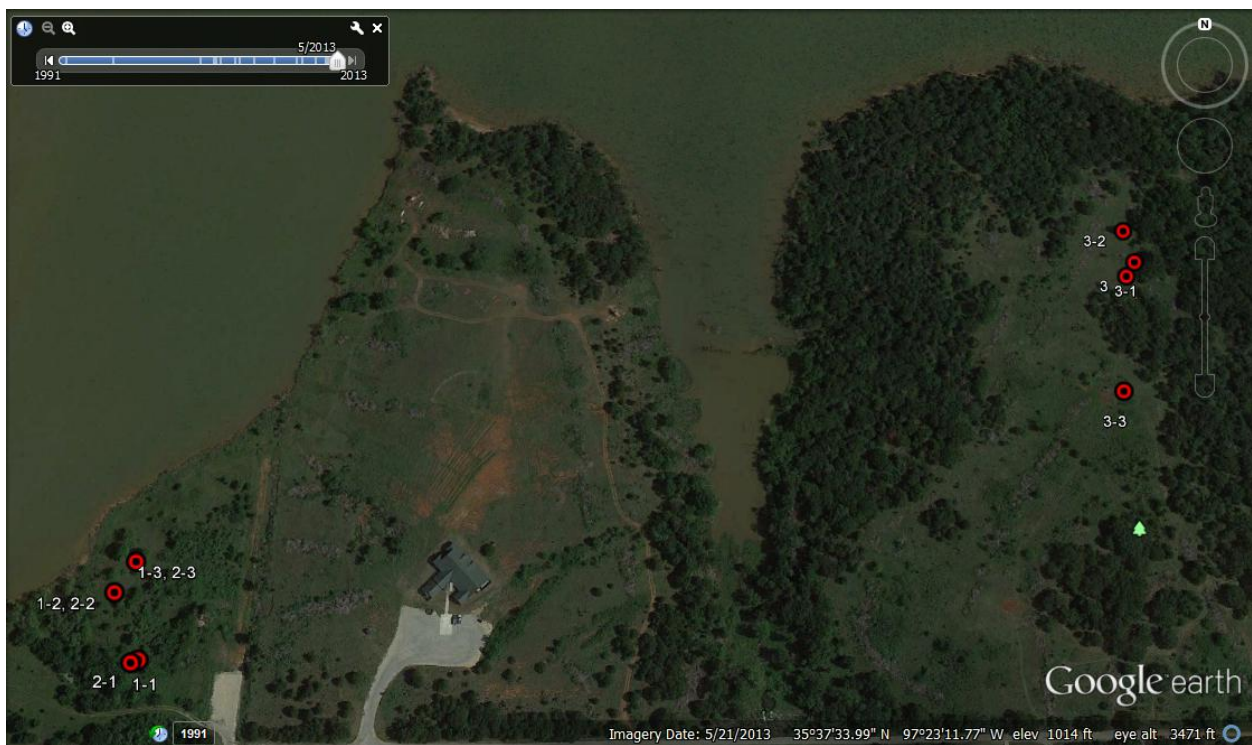

FIG. 2 – Satellite image of experiment area from FIG 1 with carcass placement locations

The first experiment was started on October 30, 2012, which overlapped with the local annual deer bow hunting season. The majority of the preserve was open to hunting, except for the area used in the experiment. This area was used so as to stay out of the hunted area for the safety of the researchers and to not disturb the hunters' activities. The area was also used for the second experiment started on February 24, 2013. Other areas of the preserve were open to

access, but this region was used again in order to gather the most comparable data to the first experiment set. The third experiment consisting of carcasses 3, 3-1, 3-2, and 3-3 was conducted in a different area on the east side of the preserve (Figure 2). This was mainly due to the unexpected flooding of the original area in early June 2013. It was also moved to insure that data was not skewed by saturation and expectation of food sources, and to avoid creating a “feeding station”. Constant access to expected carcasses at the same location has been shown to change behavior patterns of predators and scavengers (Cortes-Avizanda et al., 2009).

## **Specimens**

Domestic pig (*Sus scrofa*) carcasses were used as analogues to human remains in this research project. They have become the staple human analogue in forensic research after countless successful studies (Morton & Lord, 2006; O’Brien et al., 2007; Kjørlien, Beattie, & Peterson, 2009; Reeves, 2009; O’Brien et al., 2010). This is mostly due to the species being closest in body mass, proportion, and decomposition sequence to humans (Reeves, 2009; Calce & Rogers, 2007; Kjørlien, Beattie, & Peterson, 2009; Schotsmans et al., 2011). They have hair instead of fur, unlike other vertebrates, and in similar variations. Pigs’ skin structure, fat-muscle ratios, and physiology are also similar to humans (Schotsmans, et al., 2011).

Three domestic pig carcasses of roughly the same size as each other were used for the first two sets of experiments, with the first set of carcasses being 20-35 kg (60-70 lbs.), and the second being 55-70 kg (120-150 lbs.). The third phase of the experiment varied slightly with a single large carcass 70 kg (150 lbs.) placed twenty days before the set of three smaller carcasses 20-35 kg (60-70 lbs.), due to it becoming available unexpectedly (Table 1). The specimens were obtained from the University of Oklahoma, College of Medicine, the Oklahoma State University, Swine Research Center, and from donations by a local farmer. Carcasses obtained from the

University of Oklahoma were euthanized by anesthesia after being used for endoscopic surgical curricula and were then reused for this project, rather than being destroyed. Carcasses obtained from the Oklahoma State University Swine Research Center were natural deaths. Carcasses obtained by donation were euthanized by .22 caliber rifle shot to the forehead, due to illness. The project was conducted under IACUC authorization #7008, #7009. The specimens were approximately similar in size per experiment, although they varied among experiments. Carcasses 1-1, 1-2, 1-3, 3-1, 3-2, and 3-3 weighed between 20-35 kg (60-70 lbs.). Carcasses 2-1, 2-2, 2-3, and 3 weighed between 55-70 kg (120-150 lbs.) (Table 1). Carcasses were placed within twenty-four hours of being obtained. No carcasses were frozen, although several were kept on ice or refrigerated overnight. Freezing and storage of the carcasses would have introduced an additional variable that was not to be considered in this experiment design. The effects of freezing of the corpse on scavenging behavior are left to the provenience of future research.

All of the experiments were set up in the same manner for consistency in data collection and comparability of results. A large nail was hammered into the ground at the nose of each of the carcasses, for a semi-permanent marker of their original position. GPS coordinates of this position were documented. One of the carcasses was placed within a scavenger proof cage (1.5 m x 1 m x 0.5 m) which consisted of a metal frame covered with a thin mesh wire. The bottom of the cage was covered with wire mesh for the second and third phases of the experiment after a breach of the cage by an opossum in the original experiment (which will be discussed at length in a later section). The cage was quite heavy and the legs were embedded in the ground, making it highly unlikely that it could be turned over by any of the local wildlife. This followed standard procedure that has been established in the literature (Reeves, 2009; O'Brien et al., 2010).

Carcasses 1-2, 2-2, and 3-2 were placed undisturbed directly on the ground and left exposed. Carcasses 1-3, 2-3, and 3 were modified to allow for the implantation of radio transmitters into medullary cavities of long bones. Some musculoskeletal tissue was removed in order to allow access to long bones. The widest part of the bone was chosen, for example the proximal end of the tibia, to allow for as wide of a marrow cavity as possible for a good fit of the transmitter. The transmitters were approximately 2 cm long by .75 cm wide, similar in diameter to a pen. Then using 1.25 cm “hole saw” and a hand held battery powered drill, a small circular piece of bone was removed. Some of the marrow behind the piece of bone and into the cavity was removed as well. The transmitter (Wildlife Materials, Inc. SOPI) was then placed as deeply in the cavity as possible; the marrow and bone were then also put back. Non-toxic blue putty was used to keep the pieces of bone in place. The blue putty not only helped keep the bone plug from falling out, but allowed for easy visual confirmation that the transmitter was still inside the bone.

The transmitters were used to facilitate search efforts. Even with video evidence and daily or semi-daily searches, bones moved large distances are difficult to find. The use of transmitters was designed to allow for more accurate and larger area searching in order to track where bones were being taken and to find their final resting place. This was to address the observation that coyotes cache parts of carcasses (Koehler & Hornocker, 1991). The radio transmitters allowed for the long distance tracking of bones which were moved out of the viewable area of the cameras. This method proved quite successful in several cases, although several transmitters were lost during the study, either due to interference, malfunction, or damage. The transmitters were tracked using a radio receiver (Wildlife Materials, Inc.) and 3-tierd Yagi antennae (Wildlife Materials, Inc). The transmitters had a range of over a mile and a battery life of over a year. Many of the recovered transmitters were reused in following

experiments. Transmitters were implant grade, non-toxic, and posed no threat to wildlife that encountered them.

TABLE 1—*Treatment of carcasses by experiment, with carcass weight and season*

Experiment	Carcass #	Treatment	Weight Range
1 (Fall)	1-1	In cage	20-35kg
	1-2	Directly on ground	20-35kg
	1-3	Implanted with transmitters	20-35kg
2 (Winter)	2-1	In cage	55-70kg
	2-2	Directly on ground	55-70kg
	2-3	Implanted with transmitters	55-70kg
3 (Summer)	3	Directly on ground	70kg
	3-1	Directly on ground	20-35kg
	3-2	Directly on ground	20-35kg
	3-3	Implanted with transmitters	20-35kg

### Observation

The site was monitored continuously throughout the experiment period by both electronic surveillance and regular site visits. The carcasses were monitored with battery powered motion triggered trail/game cameras (Moultrie, GameSpy I-85) with infrared flashes (Reeves, 2009;

Spradley, Hamilton, & Giordano, 2012; O'Brien et al., 2007), and a DVR system with video cameras that ran 24 hours a day (Morton & Lord, 2007; O'Brien et al., 2007, 2010). The DVR system was a Swann 4-950, and was run off of two Optima Blue Top dual cycle marine batteries (Figure 3). Four total cameras were connected to the DVR, which were also equipped with infrared lighting and night filming capabilities. The cameras were mounted on Johnson construction tripods and were focused on the carcasses. Two cameras were placed viewing each of the two non-control carcasses, one at a close up range and one to capture the overall area. A trail camera was used to monitor the control. All of the cameras were moved as needed upon site visits to insure that carcasses remained in view and quality data was collected. Cameras were removed from the site when scavenger activity had ceased, or it was time to start the next experiment

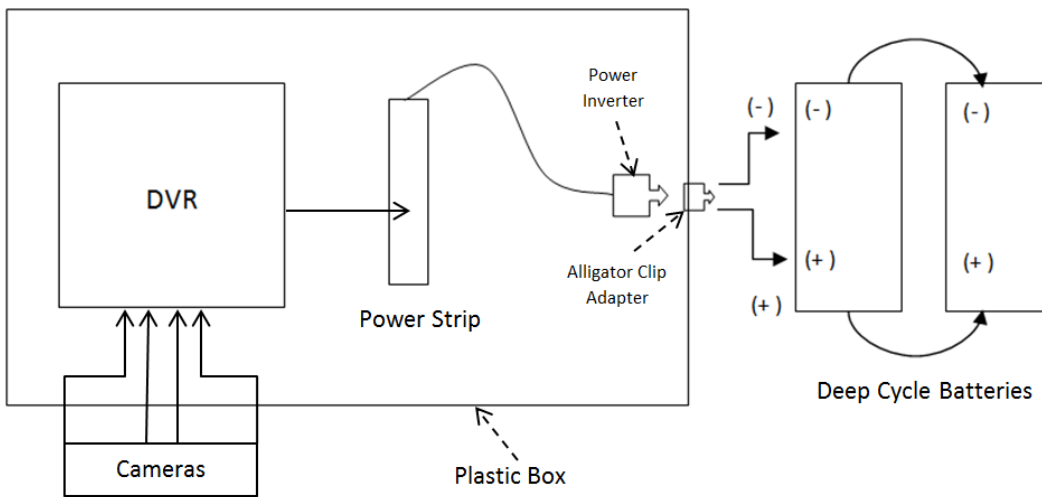

FIG. 3 – Diagram of DVR field power setup

The site was visited every other day at the beginning of each experiment, with the frequency tapering off to weekly visits as the movement and usage of the carcass diminished or stopped completely. At each visit the carcasses were photographed using a Nikon D-90 digital

SLR camera with 55-200mm Nikon lens. Any changes in the condition of the carcasses were noted, and movement of elements, or whole carcasses, was also recorded. GPS coordinates of the original deposition location, based on the nail placed at the nose of each carcass, were taken for each experiment. Distance of elements dispersal from the original deposition site was measured from this point. Measurement techniques varied depending on distance from the carcass, line of site, and terrain. A range finder (Nikon Game Hunter) was used in many instances where traditional measuring tape would not suffice due to vegetation and terrain. A wheel measure was also employed in rough terrain. Distances that were out of line of site of the original deposition site were measured using GPS coordinates, and triangulation methods.

### **Experiment Time**

The experiments were roughly timed to coincide with different seasons. As the availability of carcasses was unpredictable, it was not possible to coordinate perfectly and there are some gaps and overlap. However, there is a strong representation of different weather conditions, temperature variation, and seasonal variation. The first experiment is considered fall/early winter, the second late winter/early spring, and the third late summer/early fall.

The majority of scavenger studies to date have only measured scavenger activity up until the remains were mostly or completely skeletonized (Reeves, 2009; Kjørlién, Beattie, & Peterson, 2009; Morton & Lord, 2006; Spradley, Hamilton, & Giordano 2012; O'Brien et al., 2007, 2010). The longest of these was conducted over only 74 days (Morton & Lord, 2006). One of the major design focuses of this research was to look at what happens to skeletal elements after they have been exposed for extended time periods. It is well noted that bones are utilized by many animals as a source of calcium and marrow. Therefore scavenging as a taphonomic process does not end when soft tissue is gone. There are still useful resources. Skeletal elements were left



in the field and observed until they were either completely removed or the research was concluded in March 2014. All persisting skeletal elements were collected and mapped.

### **Data and Analysis**

Tables of element groups with tallies of presence and absence of elements were created after the final surveys and collections were made. Maps of final skeletal dispersals were created using field measurements. These maps were compared in order to assess patterns in dispersal. Range and direction of scatter were compared for patterns. Figures were created based on video data of scavenger visit times for all experiments, which chart species, visit time, and sunrise and sunset. Skeletal elements were examined for taphonomic indicators of scavenger activity. Overall percentages of diagnostic skeletal elements such as teeth, crania, and pelvic elements recovered from each experiment were compiled into a table.

Temperature and humidity data were collected using Tiny Tag Plus 2 data loggers. The data loggers were set to take temperature and relative humidity measurements at 15 min intervals throughout a 24 hour period. Average daily temperature was calculated from the interval temperature data and used to calculate accumulated degree days (ADD) for all experiments according to Megyesi, Nawrocki, and Haskell (2005). Total body score (TBS) was also assessed using the scoring system established by the aforementioned authors. Statistical calculations were computed using GenStat© 15<sup>th</sup> edition statistical package. All collected data was used to evaluate the presence of trends in scavenging behavior, such as patterns in visit time and carcass usage, and the subsequent effects on carcass displacement. Patterns were evaluated for their forensic significance and usefulness in informing forensic death investigations and searches for remains.

**Chapter 3:**

**Facultative Necrophagus Scavenging and Carrion Guild Participation by *Lynx rufus* in the Presence of Young\***

*\*Prepared and formatted for submission to the Journal of Mammalogy*

**Abstract:** The bobcat (*Lynx rufus*) is described as an obligatory predator who rarely scavenges, having a strong preference for fresh prey. Scavenging by the species has only been implied from stomach contents analysis. Our recent carrion utilization study in north central Oklahoma revealed long term, repetitive scavenging by an adult female bobcat and her cub at experimentally placed domestic pig (*Sus scrofa*) carcasses over a 7 day period. Increasing duration of visit times occurred from initial discovery to dispersal of the carcasses. These observations suggest that bobcats will readily exploit fresh carrion when under the demands of rearing young. Bobcats possibly play an overlooked role in the guild of carrion recyclers in suburban and semi-rural cross-timbers ecosystems subjected to human encroachment. Carrion scavenging by bobcats might become more common and prominent as fragmented habitats increase.

**Key words:** carrion utilization, fragmented habitat, human encroachment, resource partitioning

Scavenging is an integral part of ecological systems, which conserves and recycles energy from carrion within a complex food web. Carrion consumption is often considered from the perspective of the non-vertebrate decomposers such as insects and fungi (DeVault et al., 2011). Likewise, past research, has focused on necrophagus foraging behaviors in undisturbed ecozones containing diverse vertebrate scavenging communities, such as Yellowstone National Park (DeVault et al., 2011). However, in fragmented habitat, seemingly obligatory predators have been observed to become facultative scavengers and begin to play a broader ecological role (DeVault et al., 2011). As natural areas become modified for farming, ranching, and human habitation, prey populations are condensed and fragmented, potentially altering the behavior of predators as they move to exploit new niches and resources. Bobcats have previously been unrecognized as participants in the guild of necrophagus scavengers in this environment.

The bobcat is widely distributed from southern Canada to northern Mexico and is present in all of the 48 contiguous states of the U.S., with the exception of the Ohio River Valley, the southern Great Lakes region, and the northern Mississippi Valley, where they have been overhunted and mostly eradicated (Larivere and Walton, 1997; Brockmeyer and Clark, 2007; Rippley et al. 2012). Bobcats are almost exclusively carnivorous, with rabbits and other small rodents, such as mice and squirrels tending to dominate their diets (Rolley and Warde, 1985; Thornton, Sunquist, and Main, 2004; Brockmeyer and Clark, 2007). They generally consume all parts of small to medium sized prey and can readily digest the bones of small mammals (Brockmeyer and Clark, 2007). Carrion scavenging is not considered common behavior in these animals, but has been documented both directly and indirectly. Adult bobcats were noted to have scavenged on 5% of deer carcasses examined in an Idaho study, compared with 79% of the carcasses which were scavenged by coyotes (Koehler and Hornocker, 1991). Other studies have

found large quantities of deer tissue in the stomach contents of harvested bobcats (Brockmeyer and Clark, 2007). While bobcats are capable of catching and consuming larger prey such as deer, only 10% of deer carcasses examined showed signs of being killed by bobcats (Koehler and Hornocker, 1991). It is likely that bobcats, similar to other predators, are opportunistic scavengers, and forage upon the remains of wounded or diseased animals, especially in winter. The low percentage of deer whose death was directly linked to bobcat predation, when contrasted with the high percentage of deer in stomach contents seasonally in winter supports this theory. Necrophagous scavenging behaviors in winter months were also observed in a forensic study where a single bobcat was documented feeding on a human corpse (Rippley et al., 2012).

During a carrion utilization study in north central Oklahoma, a female bobcat and cub scavenged heavily at placed domestic pig (*Sus scrofa*) carcasses for a total of 7 days. This is the first directly observed participation by the bobcat in carrion resource partitioning as part of the carrion recycling guild. Foraging duration and carcass visitation frequency indicates that female bobcats might readily engage in necrophagous foraging behaviors at carrion, especially when caring for young.

### **Materials and Methods**

*Study area.*—We conducted this research at the Oklahoma Department of Wildlife Conservation's 226.6 ha Lake Arcadia Conservation Education Area, in north central Oklahoma (Fig. 1). The area is a combination of riverine habitat, mixed grassland prairie, and cross-timbers. The cross-timbers eco-region covers large areas of central Oklahoma. It is comprised mainly of scrub oak forest interspersed with tall-grass prairie (Disney et al., 2008). This diverse landscape provides habitat for a wide variety of mammalian species including large predators and

mesopredators, as well as small omnivores (Disney et al., 2008). The area is surrounded by semi-rural and suburban housing. The area is open to the public and is frequently used by humans for outdoor recreation, fishing, and bow deer hunting.

*Carcass treatment and placement.*—We obtained 3 domestic pig carcasses (*S. scrofa*) by donation of a local rancher, which had been euthanized by .22 caliber rifle shot to the forehead due to illness. This experiment was conducted in accordance with the guidelines for the ethical treatment of animals in research established by the American Society of Mammalogists (Sikes et al., 2011) and conducted under the approval of the University of Central Oklahoma I.A.C.U.C. (authorization #7008, #7009). Carcasses were placed at the study area on 10/30/2012. Each carcass was treated differently in order to evaluate varying aspects of scavenger behavior. A single carcass was placed in a scavenger proof cage (1.5 m x 1 m x 0.5 m) to serve as a control as is standard practice in scavenging studies (O'Brien et al., 2007, 2010; Reeves 2009). The second carcass was placed directly on the ground 52 m due north of the control and left exposed. The third carcass, which was skinned and gutted, to speed up the disarticulation and movement of skeletal elements by scavengers, was placed 26.5 m to the northeast of the second carcass.

*Observation and analysis.*—The carcasses were monitored 24 h a day with a digital video recorder (DVR) system (Swann, model 4-950) along with motion triggered trail/game cameras (Moultaire, GameSpy I-85) which were set to take 3 photos each time the sensor was engaged with a 6 second delay between photo sets. Site visits were made every other day to document and monitor the carcasses' condition and location. The carcasses were observed until they were completely moved from the study area on 11/7/2012. Tinytag Plus 2 data loggers were used to collect temperature and humidity data. All photographic and video data was viewed and analyzed for scavenger presence, duration of stay, and behavior, and all activity was noted on data log

sheets. Video data was reviewed multiple times, often under enhancement, and saved to several hard drives, for future use.

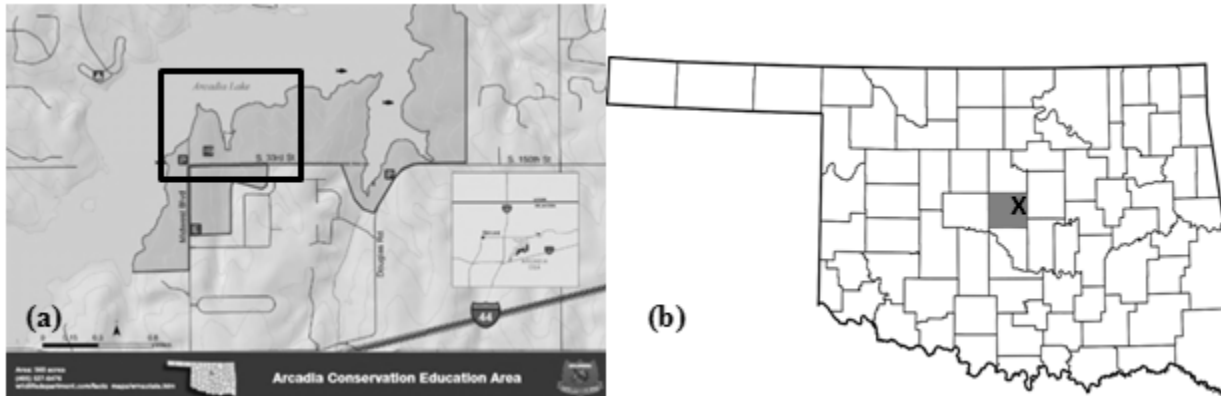

FIG. 1.— a) Map of preserve area with experiment area (black box) as situated within the boundaries of the wildlife management area (gray area), and b) the state of Oklahoma with the Oklahoma City metropolitan area (in dark gray) and the location of the experiment area (X). Reprinted with permission of the Oklahoma Department of Wildlife Conservation.

## Results

*Temporal scavenging activity.*—The first scavenger to appear at the placed carcasses was an adult female bobcat. It visited the skinned and gutted carcass at 20:01 on 10/31/2012; approximately 20 h after the carcasses were placed. At the first 2 visits, the bobcat briefly investigated the area sniffing around the carcass and scent marking the immediate area. These first 2 visits were separated by 25 min and lasted 1.5 min and 30 s respectively. At 21:11 the bobcat returned and spent 46.5 min feeding at the carcass. This behavioral pattern of short investigative passes followed by substantially longer durations of feeding repeated throughout the 7 day period at both carcasses. The duration of feeding episodes increased throughout the observation period. At the last feeding observation, the bobcats fed for just over 2 h. Average visit duration was 15.83 min. Average temperature at visits was 10°C.

Scavenger visits, by species, are outlined in Fig. 2 according to experiment day and time. These visits demonstrate a clear delineation in the time that the different scavenger species

visited the carcasses. The bobcats were often active during the middle of the day, but maintained an overall pattern similar to those previously documented (Ripley et al., 2012) with the majority of their activity falling between the hours of 04:00-10:00 and 18:00-24:00. The opossums (*Didelphis virginiana*) also fed heavily between 19:00-24:00, overlapping with bobcats' feeding times. The two species did not share carcass space simultaneously, but would access the carcass one after the other, often multiple times as can be seen on experiment days 4, 5, 6, and 7 (Fig. 2).

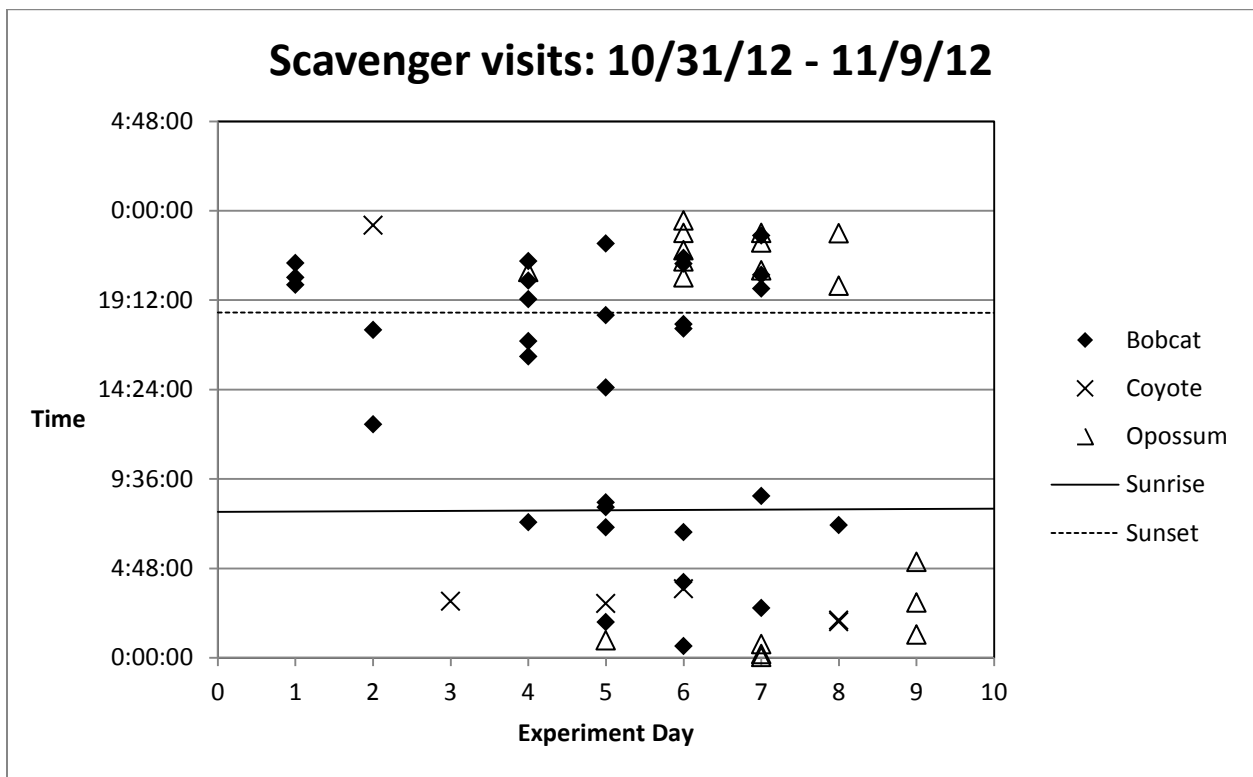

FIG. 2.—Scavenger visits by species, experiment day, and time, with sunset and sunrise derived from the Oklahoma Department of Wildlife Conservation's sunrise and sunset table at [www.wildlifedepartment.com](http://www.wildlifedepartment.com).

*Feeding behavior.*—The adult female bobcat fed alone at the gutted carcass. This carcass was removed from the area within 2 days of placement by a coyote (*Canis latrans*). Once this carcass was unavailable, the adult bobcat moved to the second, untreated carcass. The adult female was joined at this carcass by a juvenile bobcat presumed to be its cub, as bobcats are



solitary other than female-offspring groups (Janečka et al., 2006). The cub was also much smaller in size and had less developed facial tufts. Young bobcats are born between late April and June, they typically wean at around 4 months of age (Rolley 1985; Larivere and Walton, 1997). They begin accompanying their mothers on foraging trips at about 3 months of age and will start to travel alone at around 6 months (Larivere and Walton, 1997). Due to the cub being somewhat autonomous, yet still being with the mother at that particular time of year, we estimated cub age to be 6-7 months. Sex could not be determined. It was confirmed visually through markings and size that the same two bobcats, and not multiple other cats, were being observed throughout the experiment.

While the bobcats were in the area of the carcass contemporaneously, they did not always feed simultaneously. The adult often sat at lookout while the cub ate. The cub investigated and played as the adult ate. However, there were several incidences where the two were caught on camera together (Fig. 3). The first confirmation of the adult bobcat being accompanied by a cub occurred on 11/4/12 at 07:00. From this point on, most of the visits involved both of the bobcats, instead of just the adult, which had been feeding alone at the first carcass.



FIG. 3.—Mother and cub feeding at the whole untreated carcass on day 7 of the experiment.

*Carcass concealment and tissue consumption.*— The adult bobcat was observed covering the untreated carcass with grass and leaves. She was more thorough initially in this endeavor and less so as time went on. The first day that the adult bobcat visited the untreated carcass, she completely covered the carcass to the extent that it was hardly visible (Fig. 4). By the last day the carcass was present it lacked concealment of any kind. She used dead grass and leaves from the immediate vicinity, while it was in the more open area, and leaves and sticks when the carcass was in the stand of scrub trees, where it was last observed. Availability of items to cover the carcass did not diminish, and was not a factor in carcass concealment.



FIG. 4.—The untreated whole carcass covered with grass and debris by an adult bobcat on 11/2/2012

The bobcats began feeding at the neck and shoulder region of the carcass. They fed heavily on large muscle groups, stripping the carcass to bone in many places. They were not observed feeding on viscera or integument of the intact carcass. In several instances, the female bobcat was observed tearing and pulling at the hide to separate it, exposing skeletal muscle and fat (Fig. 5). The bobcats remained in the area and fed on the untreated carcass until it was reduced to only skin and bones. A coyote then removed it from the area.



FIG. 5.— Adult bobcat separating integument from ribs of the whole untreated carcass.

*Scavenger guild and resource partitioning.*—Bobcats were not the only scavengers feeding on the carcasses during the observation period (Fig. 2). Carcasses were also frequented by opossums and coyotes. It is important to note that an adult coyote, like the bobcat, was also accompanied, at one visit, by a young pup. These three species, displayed distinct foraging patterns, and fed on different parts of the carcasses (Table 1). The opossum fed heavily on internal organs and viscera. The coyotes concentrated on the hind limbs and pelvis area, and eventually the bones and integument. The coyotes subsequently dragged the remaining components away from the area once they were reduced to bone, connective tissue, and integument, effectively dispersing the terminal carrion resource. While other species known to scavenge were present at the study area such as American crow (*Corvus brachyrhynchos ssp*), Turkey vultures (*Cathartes aura*), raccoon (*Procyon lotor*), and striped skunk (*Mephitis mephitis ssp*), none were observed feeding at the carcasses. No significant insect activity was observed. There were no large maggot masses or other large insect colonies sufficient enough to deter scavenger activity or have impact on decomposition.

**Table 1.** —Resource partitioning general observations, including average time of day of visit, the areas of the carcass fed upon, and other significant behaviors.

Species	Occurrence Time	Tissues Foraged	Other Observed Behaviors
Bobcat ( <i>Lynx rufus</i> )	Diurnal, with preference for dawn/dusk	Large muscle groups, beginning with shoulders/neck area	Grooming; Play
Opossum ( <i>Didelphis virginiana</i> )	Nocturnal, late night/early morning	Viscera, integument	Grooming
Coyote ( <i>Canis latrans</i> )	Nocturnal, midnight to dusk	Lower limbs, bones/marrow, integument	Caching

### Discussion

The fact that bobcats scavenged on pig carcasses for long durations in this study, suggests that they might be opportunistic facultative scavengers. Although it is commonly suggested that bobcats prefer fresh kills, these observations demonstrate willingness to scavenge the remains of large vertebrates when available. The untreated carcass, which was fed on the most heavily, was exposed for 3 days before the bobcats began feeding on it. However, it stayed fresh with little insect activity and decomposition, due to the colder temperatures. This likely influenced the bobcats' choice to utilize this resource. It was a relatively fresh, free energy source. When considering the carcass resource in terms of Optimal Foraging Theory, their value becomes clearer. Energy payout of prey resources is relative to the handling time of the prey ( $h$ ), i.e. killing, eating, and digesting, and the search time ( $s$ ), i.e. time it took to seek out the prey resource ( $\frac{E}{h+s}$ ). The caloric value of a pig carcass is 472 kcal/100 g, in contrast an average rabbit is approximately 117 kcal/100g (U.N. Food and Agriculture Organization, 2014). The bobcat itself needs to consume, on average, 138 kcal/kg per day in all seasons (Lariviere and Walton, 1997). This comparison shows the greater value of the carrion resource. Since there is relatively

no search time involved in the use of the carrion resource once it has been initially located, as compared to hunting rabbits or mice, the carrion is much more valuable, even if small prey were excessively abundant. While swine is not a typical food source in bobcats, this new energy source might not be rejected in lieu of typical prey due to its low handling and searching time compared to high energetic payout.

Bobcats have been noted to stay and rest near their fresh kills (Larivere and Walton, 1997). The availability of this resource led them to stay in the area and watch the carcass as if it was a kill they had made. It is likely that the felines never left the area, and in fact there were several instances where the adult bobcat visited the carcass within a half hour of the researcher leaving the area, indicating that they were close and likely keeping an eye on the opportunistic meal. This would also explain why the female spent a good deal of time and energy covering the resource at the beginning of the feeding events, trying to protect and hide her 'kill'. This behavior would potentially increase the resource holding ability of the bobcat, which would become less pertinent as the resource became less valuable. This might be reflected in the drop off in energy spent to cover the carcass over time.

Bobcats have been shown, particularly females, to prefer areas with some open grasslands in the winter months (Rolley and Warde, 1985; Larivere and Walton, 1997). The area where the carcasses were dropped was an open grassy area surrounded by small stands of trees and brush. This is ideal habitat for these animals, as well as their prey preference of small rodents and lagomorphs. It is likely that the bobcats were already maintaining a den in this area and were not drawn in by the carcass itself.

The home range of a female bobcat can be from 11 km<sup>2</sup> to 15 km<sup>2</sup> in Oklahoma (Rolley, 1985; Lavirine and Walton, 1997). However, it is likely that the home range of this particular

bobcat female is less than that due to the nature of the fragmented suburban area around the wildlife management area. The preserve itself is relatively small at only 2.26 km<sup>2</sup> and is surrounded by spread out suburban housing. There is evidence that bobcat population decreases with proximity and intensity of urbanization and that they are less willing to cross roads and developed areas than other predators such as coyotes (Ordeñana et al., 2010). The viable area of use may be smaller here than for other bobcat habitats and may have contributed to these particular bobcats scavenging as heavily as they did. There is the potential that the smaller area has less available hunting resources, possibly pushing the felids to use resources they might not under other conditions. This scavenging behavior pattern might become more prevalent in bobcats in fragmented habitats such as this one.

As previously mentioned, bobcats were not the only scavengers present at these carcasses; opossums and coyotes also scavenged. However, they each visited the carcasses at distinct times. The bobcats tended to visit the carcasses in the dawn and dusk hours. They would then be followed by the opossum that fed in the late evening, 23:00 – 01:00 (with some exceptions, see Fig. 2). The coyotes almost exclusively came in the early morning hours after midnight and before sunrise. There was no hostile competition over this resource. The opossum could have easily been run away from the carcass, but no attempts were ever made by the coyote or the bobcats. This is likely related to the high energy pay out of the carrion resource as opposed to the energy expenditure necessary to physically confront one another. However, it is noted in other research that long term carcass availability and the expectation of carcasses at a singular location will lead to changes in behavior and an increase by predators in feeding on species that come to scavenge the carrion resource and a shift away from actually using the carrion resource

(Cortes-Avizanda, Carrete, Serrano, and Donazar, 2009). So it is possible that this sympatric relationship might change over time if carcasses were constantly available.

This resource partitioning might not be entirely unusual or uncommon, because bobcats and coyotes have been shown to have sympatric home ranges, which exclude other vertebrate predators such as foxes (Chamberlin and Leopold, 2005). Coyotes tend to have a larger range that overlaps portions of several bobcats' ranges (Thornton, Sunquist, and Main, 2004; Chamberlin and Leopold, 2005). Chamberlin and Leopold (2005) accounted for the sympatric sharing of home ranges by suggesting that although they share overall space; they actually hunt in different areas of these ranges at different times. They both utilize the same prey species such as rodents and rabbits, but exploit them from different areas within these ranges. They also exploit prey in different proportions correlated to body size (Koehler and Hornocker, 1991; Thornton, Sunquist, and Main, 2004). In this presented case, the resource is the same, but they continue their natural partitioning in the form of what time they used the resource and what part of the resource they used, based on their individual energetic needs as species. Coyotes have been noted to develop temporal resource partitioning and use it rather than spatial avoidance of other competing species (Atwood and Gese, 2010). Frequently interspecific competition for resources occurs, but rarely to the extent of full exclusion. Negotiation of use of both the temporal aspect of the resource and the various parts of the resources itself were apparent in this case.

Sympatric use of a carrion resource by coyotes with another competitive predator has also been seen at wolf-killed carcasses, where wolf and coyote ranges heavily overlap (Atwood and Gese, 2010). In these instances wolves tend to monopolize carcass access and coyotes only access them after the wolves have left. The exception to this is when coyotes numerically

outnumber the wolves, and they are physically able to take the carcass (Atwood and Gese, 2010). In our experiment, coyotes were not accompanied by a large pack; no more than 2 coyotes were seen together at a time, which might explain why they did not dominate use of the carcass until it was light enough to be removed from the area.

While bobcats are considered to be atypical scavengers, they like many other predators will partake heavily in facultative necrophagous scavenging under the right circumstances. In this case, those circumstances are considered to be underpinned primarily by the presence of young. This study took place in the early fall in mild weather, with the average temperature at bobcat visits being 10 °C. There was no precipitation during the study period, and it was mild and mostly sunny during the day. They were in overall healthy condition and showed no external signs of malnutrition or disease, although internal parasite status was unknown. The domestic pig carcasses were a high-yield, opportunistic, free resource that were readily taken advantage of, likely due to the high fat content and fresh condition. This study suggests bobcats will take advantage, similar to other predators, of opportunistic carrion. The presence of the cub is seen as one of, if not the primary driver in the necrophagous scavenging behavior seen in these bobcats. Had the adult not had the added resource need of providing for the still dependent offspring, this scavenging event might not have occurred. It has been suggested in previous research that scavenging increases in the breeding season due to energetic needs (O'Brien et al., 2010). It is likely that this increase also occurs once offspring arrive, as was evident here. Further research is needed in order to understand how prolific scavenging is among bobcats, and if it is truly related to offspring dependency.



## Acknowledgments

We would like to thank the Oklahoma Department of Wildlife Conservation for access to the management area in order to conduct this research, especially officer Daniel Griffith and aquatic education coordinator Damon Springer. We thank the Office of Research and Grants at the University of Central Oklahoma, and the Forensic Science Foundation for funding. We would also like to thank Dr. William Caire, department of biology, the University of Central Oklahoma, for his assistance in the preparation of this manuscript.

## Literature Cited

- Atwood, T.C., and E.M. Gese, 2010. Importance of resource selection and social behavior to partitioning of hostile space by sympatric canids. *Journal of Mammalogy*, 91(2): 490-499.
- Brockmeyer, K.J., and W.R. Clark. 2007. Fall and winter food habits of bobcats (*Lynx rufus*) in Iowa. *Journal of the Iowa Academy of Sciences*, 114(1,4): 40-43.
- Chamberlin, M.J., and B.D. Leopold. 2005. Overlap in space use among bobcats (*Lynx rufus*), coyotes (*Canis latrans*), and gray foxes (*Urocyon cinereoargenteus*). *American Midland Naturalist*, 153: 171-179.
- Cortes-Avizanda, A., M. Carrete, D. Serrano, and J.A. Donazar. 2009. Carcasses increase the probability of predation of ground-nesting birds: A caveat regarding the conservation value of vulture restaurants. *Animal Conservation*, 12: 85-88.
- DeVault, T.L., A.H. Olson, J.C. Beasley, and O.E. Rhodes. 2011. Mesopredators dominate competition for carrion in an agricultural landscape. *Basic and Applied Ecology*, 12: 268-274.
- Disney, M.R., E.C. Hellgren, C.A. Davis, D.M. Leslie, and D.M. Engle. 2008. Relative abundance of mesopredators and size of oak patches in the cross-timbers ecoregion. *The Southwestern Naturalist*, 53(2): 214-223.
- Janečka, J.E., T.L. Blankenship, D.H. Hirth, M.E. Tewes, C.W. Kilpatrick, and L.I. Grassman Jr. 2006. Kinship and social structure of bobcats (*Lynx rufus*) inferred from microsatellite and radio-telemetry data. *Journal of Zoology*, 269: 494-501.
- Koehler, G.M., and M.G. Hornocker. 1991. Seasonal resource use among mountain lions, bobcats, and coyotes. *Journal of Mammalogy*, 72(2): 391-396.

- Lariviere, S., and L.R. Walton. 1997. *Lynx rufus*. Mammalian Species, 563: 1-8.
- O'Brien, R. C., S.L. Forbes, J. Meyer, and I.R. Dadour. 2007. A preliminary investigation into the scavenging activity on pig carcasses in Western Australia. Forensic Science, Medicine, and Pathology, 3: 194-199.
- O'Brien, R.C., S.L. Forbes, J. Meyer, and I.R. Dadour. 2010. Forensically significant scavenging guilds in the southwest of Western Australia. Forensic Science International, 198: 85-91.
- Ordeñana, M.A., et al. 2010. Effects of urbanization on carnivore species distribution and richness. Journal of Mammalogy, 91(6): 1322-1331.
- Reeves, N. M. 2009. Taphonomic effects of vulture scavenging. Journal of Forensic Sciences, 54(3), 523-528.
- Ripley, A., N.C. Larison, K.E. Moss, J.D. Kelly, J.A. and Bytheway. 2012. Scavenging behavior of *Lynx rufus* on human remains during the winter months of southeast Texas. Journal of Forensic Sciences, 57(3): 699-705.
- Rolley, R.E. 1985. Dynamics of a harvested bobcat population in Oklahoma. The Journal of Wildlife Management, 49(2): 283-292.
- Rolley, R.E., and W.D. Warde. 1985. Bobcat habitat use in southeastern Oklahoma. The Journal of Wildlife Management, 49(4): 913-920.
- Sikes, R. S., W. L. Gannon, and the Animal Care and Use Committee of the American Society of Mammalogists. 2011. Guidelines of the American Society of Mammalogists for the use of wild mammals in research. Journal of Mammalogy 92:235-253.
- Thomas, K., and W. Walling. 2011. Arcadia Reservoir 5 Year Management Plan. Oklahoma Department of Wildlife Conservation Report.
- Thornton, D.H., M.E. Sunquist, and M.B. Main. 2004. Ecological separation within newly sympatric populations of coyotes and bobcats in south-central Florida. Journal of Mammalogy, 85(5): 973-982.
- United Nations Food and Agriculture Organization. 2014. <http://www.fao.org>

## **Chapter 4**

### **Postmortem Scavenging by the Virginia Opossum (*Didelphis virginiana*) in Metropolitan Woodlands in Central Oklahoma: Impact on Taphonomic Assemblages and Progression\***

\*Prepared and formatted for submission to the *Journal of Forensic Sciences*

**Abstract:** The Virginia opossum (*Didelphis virginiana*) is a highly active scavenger whose behavior has significant impacts on rates of decomposition and skeletonization, which have previously not been addressed. In this study, scavenging by the opossum led to the skeletonization of carcasses in half of the accumulated degree days (ADD) of a comparable non-scavenged control carcass. Opossums used body orifices, as well as natural tears caused by the decomposition process, to access internal tissues and consume them. This activity resulted in little movement of the carcass and the retained appearance of natural undisturbed decomposition. This concealed activity has the potential to cause incorrect estimates of time since deposition and post-mortem interval, as well as conceal or confuse cause of death and indicators of trauma. Likewise, scavenging by opossums left distinct tooth mark defects, which have the potential to be misinterpreted as either trauma or scavenging by other mammalian species.

**Keywords:** forensic science, forensic anthropology, accumulated degree days, bone modification, post-mortem interval, post-deposition interval skeletal taphonomy, tooth mark defects

Scavenging by vertebrates is recognized as impacting forensically important factors such as rate of decomposition, dispersal of remains, recoverability of remains, the ability to properly identify remains, and the differential diagnosis of trauma on remains (1-5). Many species of scavengers have been identified and their associated taphonomic impacts have been described. For example, scavenging behaviors of domestic and wild canids, as well as rodent modification, have been described in some detail, particularly in the Pacific northwestern United States (1-3, 6, 7). The Virginia opossum (*Didelphis virginiana*), although having been recognized as a scavenger of remains (3, 4), has received very little taphonomic consideration. A recent study of scavenger guilds in north central Oklahoma suggests that the opossum partakes in frequent scavenging activity, which may have significant implications to forensic investigations, both in terms of estimations of post-deposition and post-mortem intervals, but perhaps more importantly in the differential diagnosis of trauma and injury patterns.

The Virginia opossum is distributed in large numbers throughout the central and eastern United States, and the western coastal states of California, Oregon, and Washington (8). Its range has slowly expanded into the other western states and it has recently been found in Arizona (9). Adults are, on average, 2-3kg in size (8). The opossum is the only marsupial species in North America. Having an opposable thumb, as well as prehensile tail, renders it a highly adaptable forager (8). Opossums have a diverse opportunistic diet, consisting of considerably high percentages of carrion and insects (8). The opossum does exceedingly well in habitat that is encroached upon and fragmented by human activity. Under such conditions the opossum becomes a major suburban scavenger and carrion recycler (10). An understanding of how opossums utilize remains, what impact they have on the condition of those remains, and what

taphonomic artifacts they leave behind are significant to death investigations, particularly in metropolitan and peri-domestic areas.

## Materials and Methods

### *Site location*

This study was conducted at the Oklahoma Department of Wildlife Conservation's, 226.6 ha Arcadia Conservation Education Area, in north central Oklahoma (Figure 1). The preserve covers a mix of riverine habitat, mixed grassland prairie, and cross-timbers (11). This diverse landscape provides habitat for a wide variety of mammalian species including large predators and mesopredators, as well as small omnivores, avian and reptile species (11). Public access is allowed to the area for hiking and fishing year round. Hunting access is limited to a small number of archery deer permits annually and no other hunting or trapping is allowed. The preserve is surrounded by suburban residential housing and is in close proximity to the greater Oklahoma City metropolitan area.

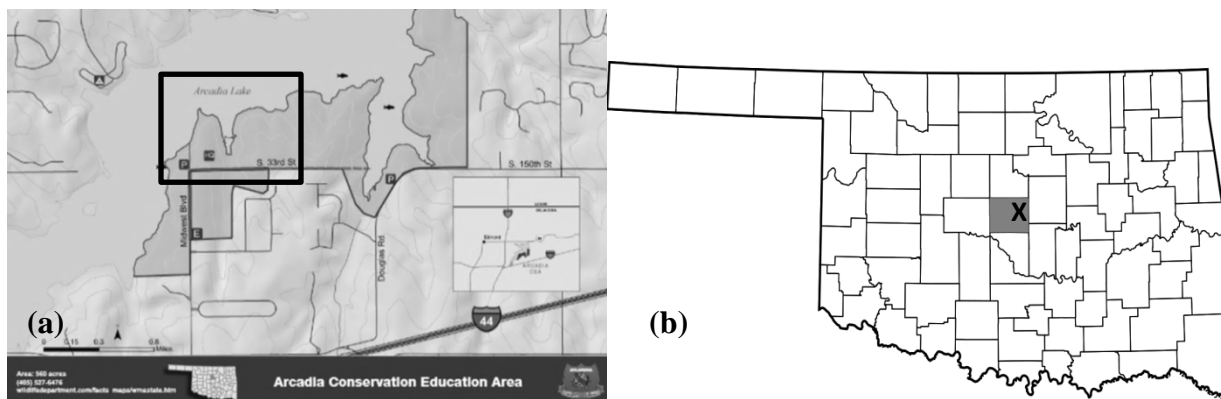

FIG. 1—Map of (a) experiment area (black box) as situated within the boundaries of the wildlife management area (gray area), and (b) the state of Oklahoma with the Oklahoma City metropolitan area highlighted and experiment area indicated (X). Reprinted with permission of the Oklahoma Department of Wildlife Conservation.

### *Specimens*

Domestic pig (*Sus scrofa*) carcasses were used as analogues to human remains, as has been established in previous forensic scavenging and taphonomy studies (4, 5, 12, 14). Three pig carcasses, which were similar in size intra-experimentally, but varied inter-experimentally, were used for each of the experiments. The specimens were obtained from the University of Oklahoma, College of Medicine, the Oklahoma State University, Swine Research Center, and from donations by a local farmer. Carcasses obtained from the University of Oklahoma were used previously for endoscopic surgical curricula at the college, and were euthanized by anesthesia. Carcasses obtained from the Oklahoma State University Swine Research Center were natural deaths. The donated carcasses were euthanized by .22 caliber rifle shot to the crania due to illness. The project was conducted under the University of Central Oklahoma IACUC authorization #7008, #7009.

### *Experiments*

Three experimental series were conducted from October 2012 through March 2014. Each carcass was individually numbered for experimental reference. Carcasses were placed at experimental field sites within twenty-four hours of being obtained. In each of the first two experiments, a central carcass was placed within a scavenger proof cage (1.5m x 1m x 0.5m), which consisted of a metal frame covered with a thin mesh wire (5, 13). Carcasses 1-2, 2-2, and 3-2 were placed undisturbed directly on the ground and left exposed. Carcasses 1-3, 2-3, and 3 were modified to allow for the implantation of radio transmitters (Wildlife Materials, Inc. SOPI) into medullary cavities of long bones in order to find their location if moved from the deposition site (Table 1).

TABLE 1—*Treatment of carcasses by experiment, with carcass weight and season*

Experiment	Carcass #	Treatment	Weight Range
1 (Fall)	1-1	In cage	20-35kg
	1-2	Directly on ground	20-35kg
	1-3	Implanted with transmitters	20-35kg
2 (Winter)	2-1	In cage	55-70kg
	2-2	Directly on ground	55-70kg
	2-3	Implanted with transmitters	55-70kg
3 (Summer)	3	Directly on ground	70kg
	3-1	Directly on ground	20-35kg
	3-2	Directly on ground	20-35kg
	3-3	Implanted with transmitters	20-35kg

*Data collection and analysis*

The study site was monitored continuously throughout the experiment period by both electronic surveillance and regular site visits. Carcasses were monitored with battery powered motion triggered trail/game cameras (Moultrie GameSpy I-85) with infrared flashes (5,12, 17), and a DVR system with video cameras that ran 24 hours a day (4, 12, 13). The DVR system was a Swann 4-950, and was run off of two Optima Blue Top dual cycle marine batteries. Four



cameras, which were equipped with infrared lighting and night filming capabilities, were connected to the DVR. The cameras were mounted on Johnson construction tripods and were focused on the carcasses. Two cameras were placed viewing each of the two non-control carcasses, one at a close up range and one to capture the overall area. A trail camera was also used to monitor the control. All of the cameras were moved as needed to insure that carcasses remained in view and that quality video data was collected. Cameras were removed from the site when scavenger activity had ceased.

The site was visited every other day at the beginning of each experiment, with the frequency tapering off to weekly visits as the movement and usage of the carcass diminished or stopped completely. At each visit the carcasses were photographed using a Nikon D-90 digital SLR camera with 55-200mm Nikon lens. Any changes in the condition of the carcasses were noted and any carcass manipulations or movement of elements was also recorded.

Activity tables were created, based on video data of scavenger visit times for all experiments, which charted species, visit time, and sunrise and sunset. Skeletal elements were examined for taphonomic indicators of scavenger activity. Temperature and humidity data were collected using Tinytag® Plus 2 data loggers. The data loggers recorded temperature and relative humidity measurements at 15 min intervals throughout a 24 hour period. Average daily temperature was calculated from the interval temperature data and used to calculate accumulated degree days (ADD) for all experiments (18). ADD measures the amount of heat loading on the carcass during the decomposition process by using the sum of average daily temperatures from the time of death until discovery. This allows for standardization and cross comparability between regional and seasonal studies. Total body score (TBS) was also calculated using the scoring system established by the aforementioned authors (18). TBS is a standardized measure of taphonomic

progression that is assessed by scoring the body in three regions: the limbs, trunk, and head and neck. Each region is assigned a number on a scale of fresh to dry bone, and then each score is combined for a total score ranging from 3 (completely fresh) to 35 (dry skeletonization).

Statistical calculations were computed using GenStat© 15<sup>th</sup> edition statistical package. Collected data was used to evaluate temporal distinctions and patterns in scavenging behavior. These included discernable patterns in carrion visit time, carcass usage, and subsequent remains' displacement. Actions such as grooming in proximity to the carcass after feeding were included in total visit duration. Patterns were evaluated for their ecological significance and usefulness in informing forensic death investigations and searches for remains.

## **Results**

The opossum was the most common scavenger seen visiting the carcasses with 188 distinct events captured on digital video or photograph, which is 70% of the total mammalian scavenger visits. Visits were defined by an animal coming into view of the camera, partaking in a scavenging related activity at the carcass, such as feeding or cleaning, and then leaving the view of the cameras. This is in stark contrast to the visit frequency of other mammalian scavengers observed throughout the experiment period. Bobcats (*Lynx rufus*) were observed on digital video or photograph feeding at carcasses only 31 times (11% of total visits) and coyotes (*Canis latrans*) 51 times (19% of total visits). Opossums were observed scavenging at 6 of 8 of the available carcasses, coyotes at 7, and bobcats at only 2. The two carcasses which were not scavenged by opossums were removed from the area by coyotes within a few days of placement.

Average opossum visit duration was highest in the first experiment with 15.34 minutes per feeding event. It was lowest in the third experiment at 4.6 minutes per visit, where average

daily temperature was highest. Using an unbalanced ANOVA, statistically significant differences in feeding duration were observed over the three experiments, ( $F_{(45, 143)} = 4.196, p < 0.05$ ). A simple linear regression, predicting feeding duration with temperature, demonstrated a correlation, ( $F_{(1, 187)} = 9.553, p < 0.05$ ), with an  $R^2$  of 0.049. Predicted feeding duration is equal to  $9.921 + 5.434(\text{TEMP})$  minutes when temperature was measured in degrees Celsius. This indicates that foraging duration is mildly influenced by temperature.

Opossums scavenged at predictable times of the day and were almost exclusively nocturnal except for a single visit that was recorded at sunrise. This pattern persisted over the course of all seasons. Opossums were observed to scavenge during all seasons of the experiment, and showed no distinct seasonal preference (Figure 2).

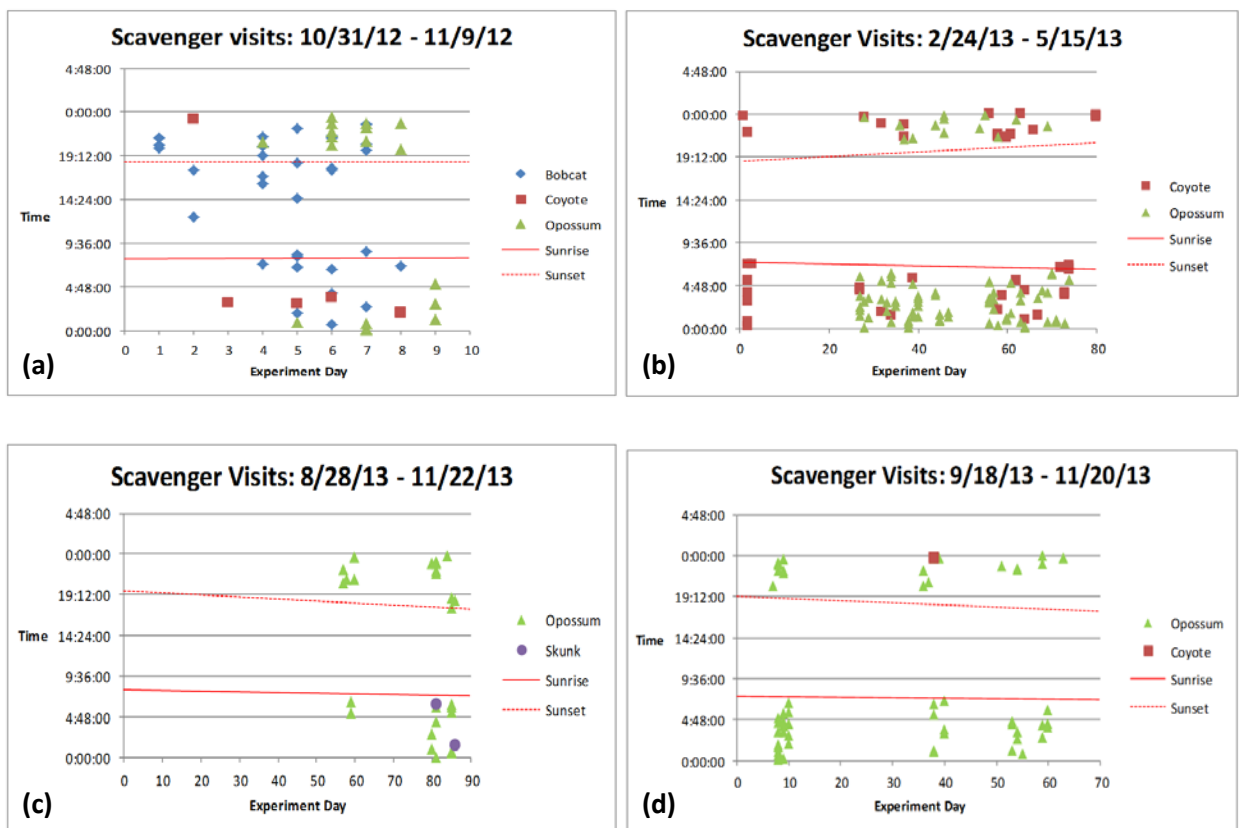

FIG. 2—Scavenger visits by species, experiment day and time, for experiment 1 (a) Fall, 2 (b) Winter, 3 (c & d) Summer with sunrise and sunset lines derived from Oklahoma Department of Wildlife's sunrise/sunset data table [www.wildlifedepartment.com](http://www.wildlifedepartment.com).

Opossums fed mostly on fresh carcass viscera. They accessed internal tissues through natural orifices, such as the anus and tears in the abdomen caused by decomposition. They did not make their own entry locations or primary wounds. This is in contrast to other scavenger guild members (coyotes and bobcats), who facilitated tissue access by integumentary cutting and tearing. The utilization of these natural orifices disrupted carrion fly activity and larva production, via spatial competition for the same locations of entry that the insects utilize to lay eggs. Additionally, opossum scavenging activities at these sites disrupted and dislodged existing masses of insect eggs. This contributed to longer fresh stage duration, and subsequently promoted scavenging by other vertebrate species. However, opossum activity did not completely prevent insect colonization. Opossum activity decreased when carcasses were heavily infested by insect larvae. Scavenging by the opossum resumed when carcasses were in advanced decay with minimal insect activity. In these later phases, opossums fed primarily on skin and bone. They were highly destructive to small bones, feeding readily on elements of the hands and feet, ribs, and edges of flat bones, such as the pelvis, scapula, and ramus of the mandible. Opossums were noted to cache small elements (vertebrae, ribs, and parts of the pelvis) under a tree in a hollowed out portion of the trunk about a meter directly south of carcass 3-1.

Two of the carcasses in the experiment were scavenged solely by opossum prior to skeletonization. Carcass 1-1, which was intended to be the first control specimen and was in the mesh wire cage, was infiltrated 13 days after initial placement. However, the cage prevented entry by other vertebrate scavengers, allowing for comparison of opossum only scavenging to that of the other species observed. This carcass, as well as carcass 3-1, (which was available to other scavengers but only visited by an opossum prior to skeletonization) showed a large difference in ADD to skeletonization when compared to that of the undisturbed control. These

two carcasses reached a total body score (TBS) of 29 (which indicates overall skeletonization with still greasy bones and some mummified tissue, on a scale that terminates with completely dry bones and a score of 35) in less than half of the ADD of the non-scavenged control (Figure 3).

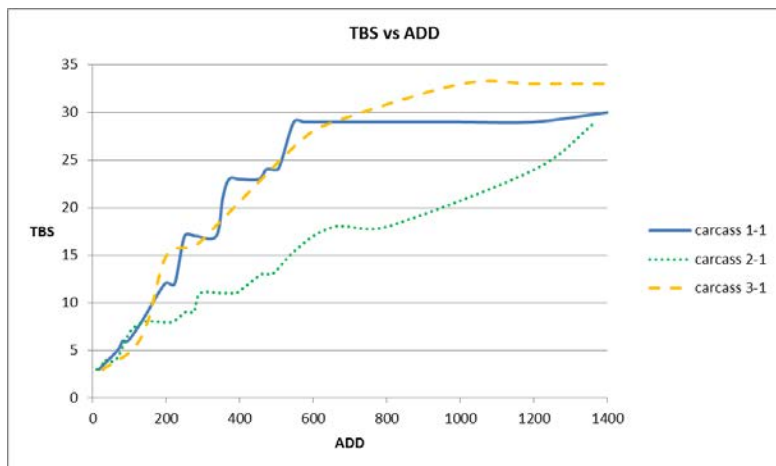

FIG. 3—Total body score by ADD for opossum scavenged carcasses 1-1, 3-1, compared to non-scavenged control 2-1.

Scavenging by the opossum produced taphonomic indicators and observable markings on skeletal remains. Ribs of carcass 1-1, displayed a pattern of splintered and fractured ends (Figure 4-6). The right scapula had gnaw-marks and punctures along the medial border (Figure 7), as well as punctures on the acromion and spine. The right mandibular condyle was also chewed and missing.

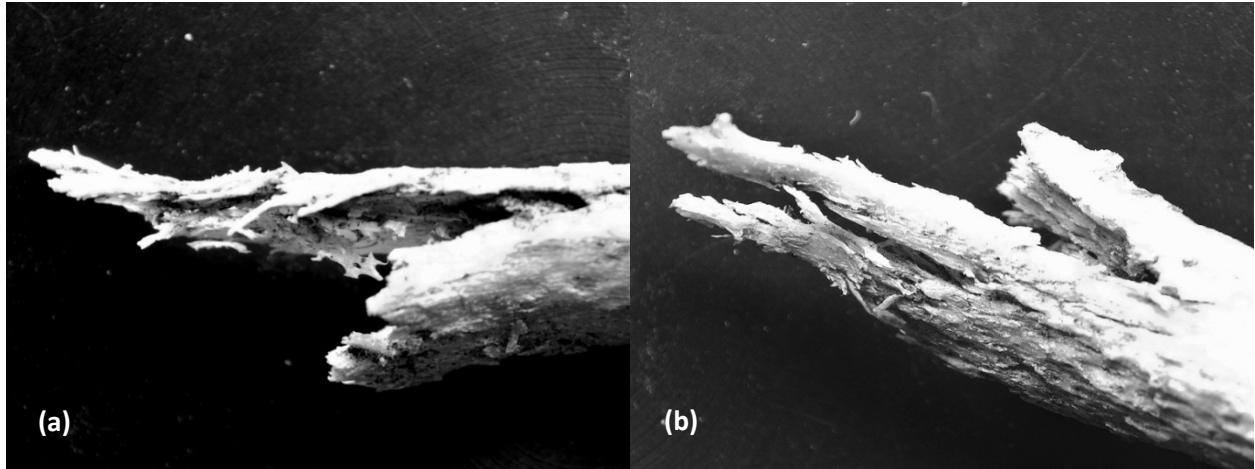

FIG. 4—*Costal rib end from carcass 1-1, with extensive splintering from opossum scavenging, (a) anterior view, (b) posterior view.*



FIG. 6—*Vertebral rib end from carcass 1-1, with splintering and breakage from opossum scavenging.*

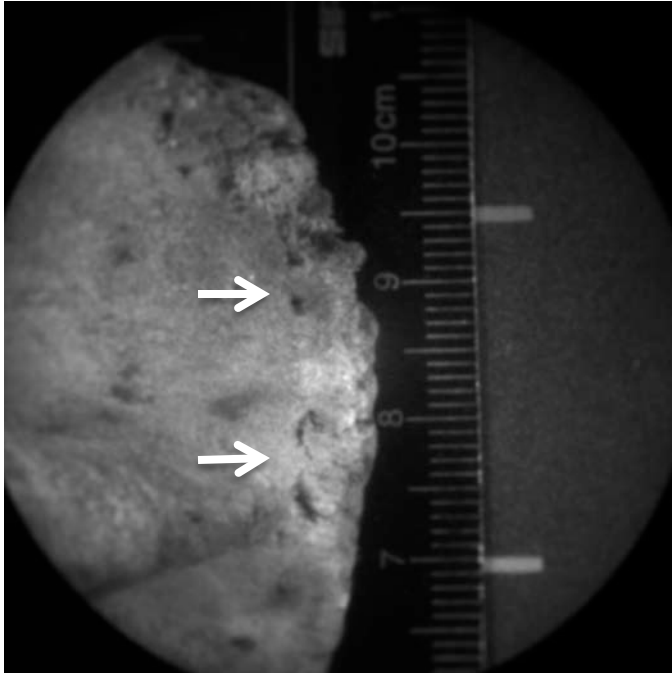

FIG. 7—Punctures and tooth mark defects on scapula of I-1 from opossum chewing, enhanced under 400nm UV light.

## Discussion

It is suggested that mammalian scavenging increases in colder temperatures (19, 20), however, in this study, opossums scavenged at relatively the same frequencies in all seasons. This frequency of opossum scavenging on the carcasses in all seasons suggests that these mammals are prolific scavengers in the semi-urban crosstimbers environments. The existing biological and ecological literature supports these findings and suggests that the opossum is a highly active scavenger in many habitats. However, the opossum has not historically been observed in these frequencies in forensic scavenging studies. The likely explanation for the discontinuity lies in the specific traits inherent in opossum carrion feeding. The opossum probably did scavenge remains in previous forensic studies, but went undetected due to unique patterns in carrion tissue access, limited remains disturbance and movement, and the similarity of

their feeding artifacts to that of canids, as well as limitations on their detection by motion triggered cameras. Game cameras in this study often failed to capture activity of animals close to the ground, especially after dark. They were also triggered less often by small bodied animals. Medium sized bobcats were able to move in the area of the game cameras without triggering their action. These cameras are designed to capture larger game, like deer and the IR sensors may not be sensitive enough to be triggered by smaller animals. Mice (*Mus sp.*) in the vicinity of the carcass were seen on the DVR but not on the game cameras. The use of the DVR allowed for better capture of these animals activities, without a reliance on a motion triggered mechanism to activate recording. The other study that captured extensive opossum scavenging also utilized video recording in conjunction with still cameras (4).

The opossum has been observed previously to cause limited disarticulation of skeletal elements (4). During this study, the opossum was observed multiple times dismembering feet. These were also the most common elements that were subsequently dispersed by the opossum or completely consumed. Poodials, metapodials, and phalanges which were recovered were heavily damaged and broken, indicating that opossums in contrast to large carnivores do not ingest these elements whole (21).

These elements tended to be consumed late in the decay cycle during the second phase of scavenging. This is an important factor when estimating time since deposition. Missing skeletal elements, such as the hands and feet, in situations devoid of canid scavenging, can indicate lengthy post deposition intervals. Dismemberment due to canid activity tends to occur soon after deposition. The timing of carcass acquisition by the opossum mimics the canid patter, but occurs much later.



The opossum fed on carrion from the inside out removing organs and viscera, and then tissue and skeletal muscle, followed by integument and finally bone. The opossum, in contrast to the other mammalian scavengers, very rarely gained access to internal soft tissue by creating wounds in the outer skin. This mimicked natural decomposition sequences of deflation following carcass bloating. Similarities in the carcasses condition between scavenging by opossums and naturally occurring late stage decomposition holds significance to forensic investigations. Without careful examination, the presence of opossum scavenging may go undetected and contribute to overly lengthy post-mortem interval estimations. For example, using data derived from this study, employing an observed TBS of 29 and utilizing the equation derived by Megyesi et al. (18) ( $ADD = 10^{(.002 * TBS * TBS + 1.81)} \pm 388.16$ ) the estimated ADD would be derived at 3104.5  $\pm$  388.16 degree days. In actuality, the TBS of 29 was achieved at 575 and 656 degree days respectively. This vast discrepancy has major implications for forensic investigations, and as such careful consideration of the impact of opossum scavenging in taphonomic ADD calculations is warranted.

Opossum scavenging, like that of other species, leaves unique tooth mark defects on skeletal elements which may be confused with that of another contemporaneous scavenger: the coyote. Distinguishing between the two is important when considering time since deposition as they access the carcass in different ways at different times. One distinct difference in the morphology of bite mark defects caused by opossum scavenging as opposed to coyote scavenging is the pattern of breakage seen in rib end fractures. In the case of opossum scavenging rib ends are frayed and splintered. The ends splay outward and are split along the length of the rib. Whereas with coyote scavenging there is crushing of the rib ends and the breaks are more perpendicular to the bone (Figure 8). There are also more rectangular shaped crushing

type breaks. In some instances, as in the rib shown in Figure 8, edges of ribs are completely sheared off.

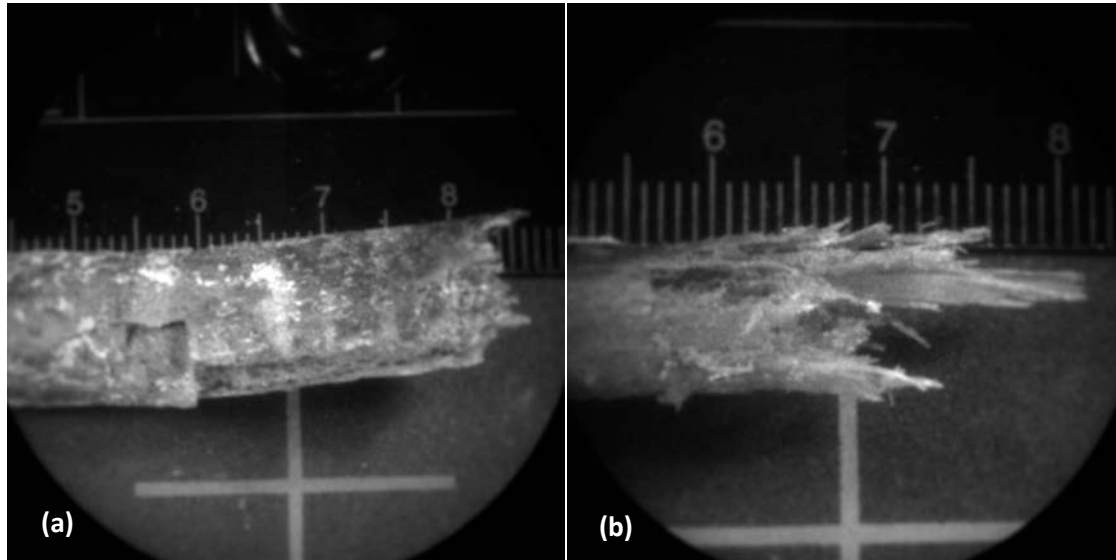

FIG. 8—Comparison of rib ends chewed by coyote (a) and opossum (b); enhanced under 400nm UV light.

This difference may originate from the way that the opossum is able to hold ribs with its opposable hallux. In both this study, and that of Morton and Lord (4) the opossum was observed holding ribs and chewing on rib ends. The opossum was observed twisting the rib while chewing on it as well as pulling it through its teeth. This biomechanical motion is very different than the manner in which a canid must leverage a bone in order to hold it steady and chew on it, resulting in a crushing downward force that leaves a different range of defects and more square fractures.

Similar puncture wounds were left by both species on the margins of the scapula and along the spine and acromion by their canines. These could be distinguished by their size. Punctures left by the opossum were 1-2 mm in diameter on average and were superficially deep. Those left by the coyote were larger than 2mm and 1-2 mm deep. A survey of coyote and

opossum dentition from the University of Central Oklahoma's skeletal collection showed a clear differentiation in the size of adult opossum and coyote canines.

Alongside the puncture wounds in both cases were depressed square-ish defects that likely correspond to premolar and/or molar cusps. Again these were smaller in size on the opossum scavenged scapula compared to those on the coyote scavenged scapula (Figure 9). The defects caused by coyote molars and premolars are almost twice as large.

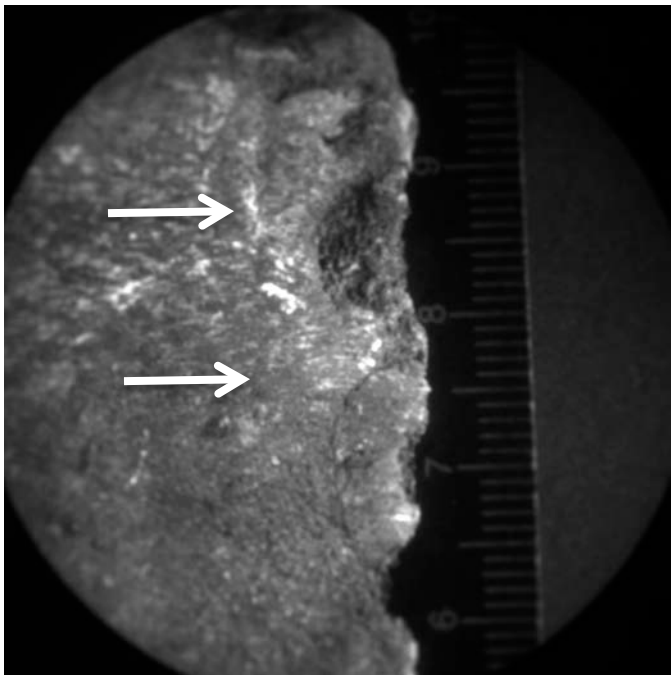

FIG. 9 —*Tooth mark defects on scapula of 2-2 from coyote scavenging; 400nm UV light.*

## Conclusions

The opossum is an overlooked, forensically significant scavenger, which leaves taphonomically distinct indicators that are important and useful for forensic investigations. Scavenging by the opossum drastically increased the rate of decomposition and lowered time to skeletonization. Using current techniques, if signs of opossum scavenging are overlooked, post-deposition/post-mortem intervals may be significantly overestimated. Due to its widespread

distribution and large populations within the United States, it essential that the necrophagus scavenging behavior of the opossum be considered in cases of advanced decay. The opossum was observed to feed heavily on remains without altering body position or location. Because feeding behaviors did not leave externally obvious markings such as bite or claw marks on soft tissue, their presence was often difficult to detect. Minute soft-tissue disturbances, which were only noticeable upon careful remains examination, were often present. Opossum scavenging, however, does leave more distinct tell-tale taphonomic defects on skeletal elements, which can also inform forensic investigations. These defects are important to recognize in terms of differential diagnosis from various forms of trauma, and they also serve to help illuminate the timeline since deposition. Further investigation is needed to determine the effects of opossum scavenging on remains and their potential impacts and benefits in death investigations in rural, metropolitan, and peri-domestic environments.

### *Acknowledgements*

We are grateful to the Oklahoma Department of Wildlife Conservation, especially Daniel Griffith and Damon Springer for providing access to the research site. We are also appreciative of Kimberly Watson and Amy Waters for aiding in searches and collections that were essential to this project.

### **References**

1. Haglund, WD, Reay, DT, Swindler, DR. Tooth mark artifacts and survival of bones in animal scavenged human skeletons. *J Forensic Sci* 1988;33(4):985-997.

2. Haglund, WD, Reay, DT, Swindler, DR. Canid scavenging/disarticulation sequence of human remains in the Pacific Northwest. *J Forensic Sci* 1989;34(3):587-606.
3. Wiley, P, Snyder, LM. Canid modification of human remains: Implications for time-since-death estimations. *J Forensic Sci* 1989;34(4):894-901.
4. Morton, RJ, Lord, WD. Taphonomy of child-sized remains: A study of scattering and scavenging in Virginia, USA. *J Forensic Sci* 2006;51(3):475-479.
5. Reeves, NM. Taphonomic effects of vulture scavenging. *J Forensic Sci* 2009;54(3):523-528.
6. Haglund, WD. Contribution of rodents to postmortem artifacts of bone and soft tissue. *J Forensic Sci* 1992;37(6):1459-1465.
7. Patel, F, Path, MRC. Artefact in forensic medicine: postmortem rodent activity. *J Forensic Sci* 1994;39(1):257-260.
8. McManus, JJ. *Didelphis virginiana*. *Mammalian Species* 1974;40:1-6.
9. Gwinn, RN, Palmer GH, Koprowski, JL. Virginia opossum (*Didelphis virginiana virginiana*) from Yavapai County, Arizona. *West North Am Naturalist* 2011;71(1):113-114.
10. DeVault, TL, Olson, AH, Beasley, JC, Rhodes, OE. Mesopredators dominate competition for carrion in an agricultural landscape. *Basic Applied Ecology* 2011;12:268-274.
11. Disney, MR, Hellgren, EC, Davis, CA, Leslie, DM, Engle, DM. Relative abundance of mesopredators and size of oak patches in the cross-timbers ecoregion. *The Southwest Naturalist* 2008;53(2):214-223.

12. O'Brien, RC, Forbes, SL, Meyer, J, Dadour, IR. A preliminary investigation into the scavenging activity on pig carcasses in Western Australia. *Forensic Sci Med Path* 2007;3:194-199.
13. O'Brien, RC, Forbes, SL, Meyer, J, Dadour, IR. Forensically significant scavenging guilds in the southwest of Western Australia. *Forensic Sci Int* 2010;198:85-91.
14. Kjørliien, YP, Beattie, OB, Peterson, AE. Scavenging activity can produce predictable patterns in surface skeletal remains: Observations and comments from two experiments. *Forensic Sci Int* 2007;188:103-106.
15. Calce, SE, Rogers, TL. Taphonomic changes to blunt force trauma: A preliminary study. *J Forensic Sci* 2007;52(3):519-527.
16. Schotsmans, EM, et al. Effects of hydrated lime and quicklime on the decay of buried human remains using pig cadavers as human body analogues. *Forensic Sci Int* 2011;217(1-3):50-59.
17. Spradley, MK, Hamilton, MD, Giordano, A. Spatial patterning of culture scavenged human remains. *Forensic Sci Int* 2012;219:57-6.
18. Megyesi, MS, Nawrocki, SP, Haskell, NH. Using accumulated degree days to estimate the postmortem interval from decomposed human remains. *J Forensic Sci* 2005;50(3):618-626.
19. DeVault, TL, Brisbin, IL, Rhodes, JO. Factors influencing the acquisition of rodent carrion by vertebrate scavengers and decomposers. *Can J Zoology* 2004;82:502-509.
20. Selva, N, Jędrzejewska, B, Jędrzejewska, W, Wajrak, A. Factors affecting carcass use by a guild of scavengers in European temperate woodland. *Can J Zoology* 2005;83(12):1590-1601.

21. Pickering, TR. Carnivore voiding: a taphonomic process with potential for the deposition of forensic evidence. *J Forensic Sci* 2001;46(2):406-411.

## **Chapter 5**

### **The Relocation and Destruction of Remains as a Result of Scavenging Behavior of *Canis latrans*\***

\*Prepared and formatted for submission to the *Journal of Forensic Sciences*



**Abstract:** The coyote (*Canis latrans*) is a highly successful facultative scavenger in metropolitan and semi-urban environments, which has significant impact on the destruction and dispersal of exposed remains. In this study, carcasses scavenged by coyotes displayed widespread destruction of skeletal elements. Often the pelvis and other diagnostic elements such as the skull were heavily damaged or unrecoverable. While some caching was evident, the majority of recoverable skeletal elements were within a 20 m radius of the original deposition site. The results from this study are most comparable to child sized remains, due to the unfused nature of the skeletal elements of the young pig carcasses used. Further research is necessary to understand if this pattern persists in human adults.

**Keywords:** Forensic Science, Forensic Anthropology, Taphonomy, Remains Scatter, Radio Telemetry

Surface deposited clandestine human remains are often the targets of vertebrate scavenging activity. This activity causes a wide array of damage to remains, much of which has been documented in both forensic and taphonomic studies (1-9). While the taphonomic defects and indicators left by the scavenging activity of some species such as canids (1) and rodents (4) have been described at length, the movement and dispersal of skeletal elements has not been adequately addressed. Movement and destruction of remains by scavengers complicates search and recovery efforts, and increases the chances of incomplete skeletal acquisition (10). Anecdotal, case study, and limited experimental data suggests that vertebrate scavenging occurs in predictable patterns (11). The most detailed studies, however, only address remains dispersal by vultures (12). Many mammalian species are known to employ scavenging behaviors and, as such, are likely to play a significant role in remains' dispersal. The coyote (*Canis latrans*), which is found throughout the United States in both urban and rural habitats is an avid carrion scavenger.

Coyotes are the most active carrion scavengers of the large mammalian predators in the United States (13). In addition to scavenging, they display caching behavior that is particularly relevant to forensic investigations. Caching can be defined as removing portions of a carcass and storing them at den and other sites for later consumption. Coyotes have been noted to be able to dismember and cache an entire deer or elk carcass in less than 24 hours (13). This caching behavior could result in large scale dispersal of remains scavenged by coyotes. It is essential to understand how feeding by this widespread facultative scavenger affects the movement and destruction of remains and how this subsequently affects recoverability. This research project evaluated patterns of skeletal element scatter due to scavenger activity and assessed the predictability of remains dispersal patterns, through a novel technique of utilizing radio telemetry

transmitters in conjunction with constant digital video surveillance. Understanding of such patterns will focus search techniques, improve remains recovery, and contribute to more timely and successful case resolution.

## Methods

### *Site location*

This study was conducted at the Oklahoma Department of Wildlife Conservation's, 226.6 ha Arcadia Conservation Education Area, in north central Oklahoma (Fig. 1). The preserve covers a mix of riverine habitat, mixed grassland prairie, and cross-timbers (11). This diverse landscape provides habitat for a wide variety of mammalian species including large predators and mesopredators, as well as small omnivores, avian and reptile species (11). Public access is allowed to the area for hiking and fishing year round. Hunting access is limited to a small number of archery deer permits annually and no other hunting or trapping is allowed. The preserve is surrounded by suburban residential housing and is in close proximity to the greater Oklahoma City metropolitan area.

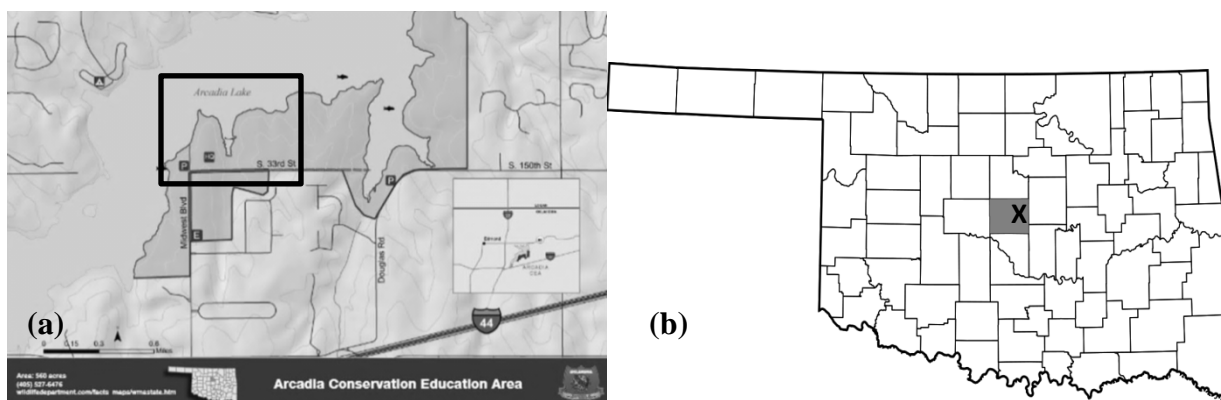

FIG. 1—Map of (a) experiment area (black box) as situated within the boundaries of the wildlife management area (gray area), and (b) the state of Oklahoma with the Oklahoma City metropolitan area highlighted and experiment area indicated (X). Reprinted with permission of the Oklahoma Department of Wildlife Conservation.

### *Specimens*

Domestic pig (*Sus scrofa*) carcasses were used as analogues to human remains, as has been established in previous forensic scavenging and taphonomy studies (4, 5, 12, 14). Three pig carcasses, which were similar in size intra-experimentally, but varied inter-experimentally, were used for each of the experiments. The specimens were obtained from the University of Oklahoma, College of Medicine, the Oklahoma State University, Swine Research Center, and from donations by a local farmer. Carcasses obtained from the University of Oklahoma were used previously for endoscopic surgical curricula at the college, and were euthanized by anesthesia. Carcasses obtained from the Oklahoma State University Swine Research Center were natural deaths. The donated carcasses were euthanized by .22 caliber rifle shot to the crania due to illness. The project was conducted under the University of Central Oklahoma IACUC authorization #7008, #7009.

### *Experiments*

Three experimental series were conducted from October 2012 through March 2014. Each carcass was individually numbered for experimental reference. Carcasses were placed at experimental field sites within twenty-four hours of being obtained. In each of the first two experiments, a central carcass was placed within a scavenger proof cage (1.5m x 1m x 0.5m), which consisted of a metal frame covered with a thin mesh wire (5, 13). Carcasses 1-2, 2-2, and 3-2 were placed undisturbed directly on the ground and left exposed. Carcasses 1-3, 2-3, and 3 were modified to allow for the implantation of radio transmitters (Wildlife Materials, Inc. SOPI) into medullary cavities of long bones in order to find their location if moved from the deposition site (Table 1).

TABLE 1—*Treatment of carcasses by experiment, with carcass weight and season*

Experiment	Carcass #	Treatment	Weight Range
1 (Fall)	1-1	In cage	20-35kg
	1-2	Directly on ground	20-35kg
	1-3	Implanted with transmitters	20-35kg
2 (Winter)	2-1	In cage	55-70kg
	2-2	Directly on ground	55-70kg
	2-3	Implanted with transmitters	55-70kg
3 (Summer)	3	Directly on ground	70kg
	3-1	Directly on ground	20-35kg
	3-2	Directly on ground	20-35kg
	3-3	Implanted with transmitters	20-35kg

*Data collection and analysis*

The study site was monitored continuously throughout the experiment period by both electronic surveillance and regular site visits. Carcasses were monitored with battery powered motion triggered trail/game cameras (Moultrie GameSpy I-85) with infrared flashes (5, 12, 17), and a digital video recorder (DVR) system with video cameras that ran 24 hours a day (4, 12, 13). The DVR system was a Swann 4-950, and was run off of two Optima Blue Top dual cycle marine batteries. Four cameras, which were equipped with infrared lighting and night filming capabilities, were connected to the DVR. The cameras were mounted on Johnson construction tripods and were focused on the carcasses. Two cameras were placed viewing each of the two non-control carcasses, one at a close up range and one to capture the overall area. A trail camera was also used to monitor the control. All of the cameras were moved as needed to insure that

carcasses remained in view and that quality video data was collected. Cameras were removed from the site when scavenger activity had ceased.

The site was visited every other day at the beginning of each experiment, with the frequency tapering off to weekly visits as the movement and usage of the carcass diminished or stopped completely. At each visit the carcasses were photographed using a Nikon D-90 digital SLR camera with 55-200mm Nikon lens. Any changes in the condition of the carcasses were noted and any carcass manipulations or movement of elements was also recorded.

Activity tables were created, based on video data of scavenger visit times for all experiments, which charted species, visit time, and sunrise and sunset. Skeletal elements were examined for taphonomic indicators of scavenger activity. Temperature and humidity data were collected using Tinytag® Plus 2 data loggers. The data loggers recorded temperature and relative humidity measurements at 15 min intervals throughout a 24 hour period.

The use of radio transmitters facilitated search and recovery efforts. Even with video evidence and daily or semi-daily searches, bones moved large distances by vertebrate scavenging can be difficult to locate. The use of transmitters facilitated more accurate tracking of bones' movement and deposition over long distances. Transmitters were tracked using a radio receiver (Wildlife Materials, Inc.) and 3-tierd Yagi antennae (Wildlife Materials, Inc). The transmitters had a range of over a mile and a battery life of over a year. Many of the recovered transmitters were reused in subsequent experiments. Transmitters were designed to be non-hazardous and implantable in live animals for biological research and posed no threat to wildlife that encountered them.

Sites were monitored continuously throughout the study duration by both electronic surveillance and regular visits. Carcasses were monitored with battery powered motion triggered

trail/game cameras (Moultrie GameSpy I-85) with infrared flashes (7, 12, 16), and a DVR system with video cameras that ran 24 hours a day (15-17). The DVR system was a Swann 4-950, and was run off of two Optima Blue Top dual cycle marine batteries. Four cameras were connected to the DVR, which were also equipped with infrared lighting and night filming capabilities. Cameras were mounted on Johnson construction tripods and were focused on the carcasses. Two cameras were placed viewing each of the two non-control carcasses, one at a close up range and one to capture the overall area. A trail camera was used to monitor the control. All of the cameras were moved as needed to insure that carcasses remained in view. Cameras were removed from the site when scavenger activity had ceased. All photographic and video data was viewed and analyzed for scavenger presence, duration of stay, and behavior, and all activity was noted on data log sheets. Video data was reviewed multiple times, often under enhancement, and saved to several hard drives, for future use.

The site was visited every other day at the beginning of each experiment, with the frequency tapering off to weekly visits as the movement and usage of the carcass diminished or stopped completely. At each visit the carcasses were photographed using a Nikon D-90 digital SLR camera with 55-200mm Nikon lens. Any changes in the condition of the carcasses were noted and any movement of elements and the carcass were also recorded. GPS coordinates of the original deposition location were taken for each experiment. Distance of elements dispersal from the original deposition was measured. Measurement techniques varied depending on distance from the carcass, line of site, and terrain. A range finder (Nikon Game Hunter) was used in many instances where traditional measuring tape would not suffice due to vegetation and terrain. A wheel measure was also employed in rough terrain. Distances that were out of line of site of the original deposition site were measured using GPS coordinates, and triangulation methods.

Tables of element groups with tallies of presence and absence of elements were created after the final surveys and collections were made. Maps of final skeletal dispersals were created using field measurements. These maps were compared in order to assess patterns in dispersal. Range and direction of scatter were also compared for patterns. Skeletal elements were examined for taphonomic indicators of scavenger activity. All collected data was used to evaluate the presence of trends in scavenging behavior, such as patterns in visit time, carcass usage, and subsequent effects on carcass displacement. Patterns were evaluated for their forensic significance and usefulness in informing forensic death investigations and searches for remains.

## **Results**

Although several species of mammalian scavengers were observed at the carcasses, the coyote (*C. latrans*) was the primary contributor to carcass dismemberment and movement. A large differential in carcass persistence was observed based on size. Small carcasses, which weighed less than 45 kg, were completely removed from the study area within a few days. In these cases, the majority of elements were completely consumed. Many of the skeletal elements were observed being consumed directly via video data. In many other instances, fragments of elements were left behind, allowing them to be observed and documented at site visits, which were later consumed during subsequent scavenging events. These instances allowed for the progression of the destruction and consumption of the skeletal elements to be directly observed. Thorough searches in these cases of both the study area and surrounding cache sites failed to recover skeletal elements. Elements that were not recovered were assumed to be consumed.

Coyotes began feeding on carcass 1-3 (20-35 kg) on the second day of the experiment, completely removing it from the area by day five. Utilizing radio transmitters, one of the legs of



the carcass was located at a distant cache site on day six (Fig. 2). This transmitter was monitored and later located at a secondary cache site with no accompanying bone. These cache sites were located over six hundred meters from the original deposition site. A leg from carcass 2-3 (55-70 kg) was also moved along this same path, in the same direction. Its final recovery was more than a quarter of a mile from the original deposition site. At recovery, transmitters were accompanied by only a few bone fragments or nothing at all. This suggests that their associated skeletal elements were destroyed, and likely consumed.

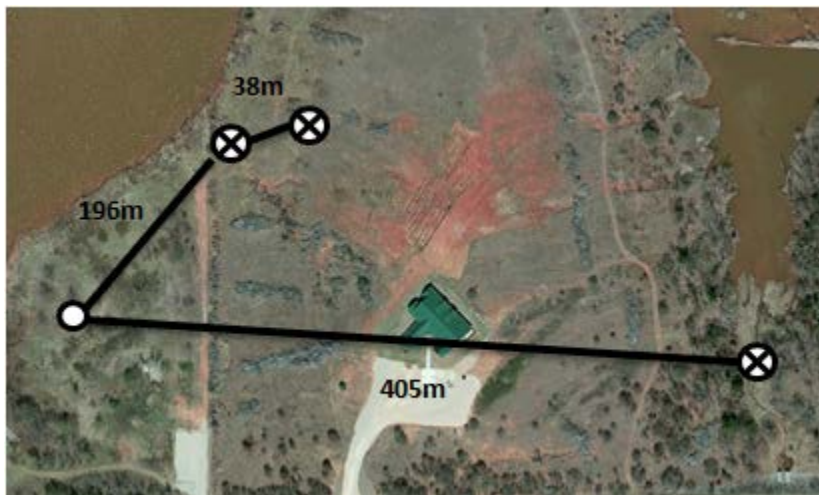

FIG. 2—Map with original transmitter location (O) and subsequent cache locations (X).

Another of the smaller carcasses, 1-2 (20-35 kg), was first scavenged on day five, which coincided with removal of carcass 1-3 from the area. By day nine only the cleaned skull and mandible were left behind. The skull was slowly reduced to fragments and consumed with all of the fragments being removed from the area by day fifty. The mandible, which had both rami removed along with some jaw bone and teeth, was the only element recovered. It was found 11.7 m to the northeast of the original deposition site along a visible game trail.

Carcass 3-3 (20-35 kg) was also dismembered and scattered within a few days of placement. It was reduced to cleaned bones by day eight with only a few small fragments remaining by day ten. There were no recoverable elements by day twelve.

Large carcasses were dismembered more slowly. Multiple drag paths were created during this process, which in some instances persisted for months. Direction of movement from the original deposition site was more obvious where grasses and other vegetation were taller. Movement also resulted in multiple stained areas where the carcasses rested and leaked decomposition fluids for a period before they were moved again. Vegetation inside these stained areas perished, while vegetation at the outer edges thrived in comparison to neighboring plants. Points of entrance and egress by the scavengers were also obvious in taller vegetation.

Coyotes dismembered carcasses primarily using a rolling or twisting motion. This often resulted in the movement of carcass elements from natural high spots down to low spots, and caused a spiral and radial rather than linear pattern of dispersal. Carcass 2-3 displayed a radiating spoke-like pattern, with elements scattered in several directions. The left hind leg was dismembered and moved along a path to the west. The pelvis was initially also drug along this path, but was subsequently moved back to the east where it was found highly fragmented with its accompanying tracker. The skull was also moved to the east and was found in proximity to a large bush, opposite the pelvis fragments. Radial patterning was also seen in the drag paths of carcass 3-3. A more linear pattern of dispersal was only observed at carcasses which had not been scavenged by coyotes until they were mostly skeletonized and largely devoid of connecting soft tissue. The dismemberment of carcasses, in all cases, started with the hind limbs.

Despite the few skeletal elements which were cached at large distances, the majority of recovered elements were found within a small radius of the deposition site. The radial patterning

of dismemberment employed by the coyote helped to contain the scatter of elements within a 20 m radius. This radius decreased to less than 10 m in carcasses which were not scavenged during early decomposition, and those that were not scavenged by coyotes at all (Fig. 3-8). Carcasses 2-2 and 2-3, which were fed on heavily while in early decomposition are scattered the greatest distances. Carcass 3-1, which was not fed on at all by coyotes is the most contained, with the majority of the skeleton being found within 5 m of the original deposition site, and many of the ribs and vertebrae actually in situ.

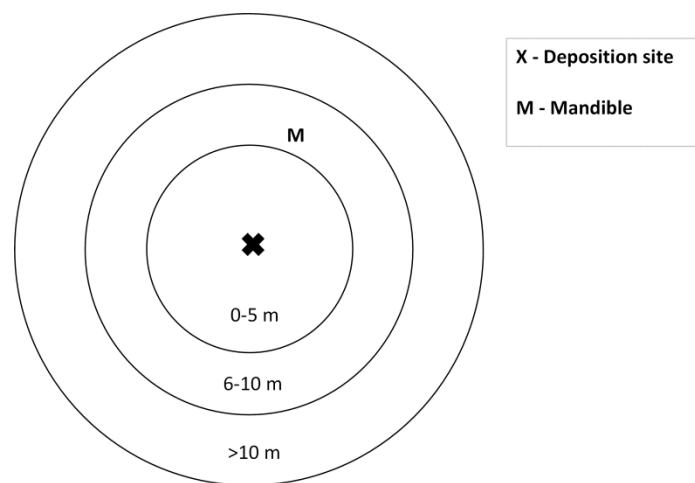

FIG. 3—Radial distribution diagram of skeletal elements at final collection for carcass 1-2, heavily fed on by *C. latrans*, *D. virginiana*, and *L. rufus* in fresh stage of decomposition. Fall season.

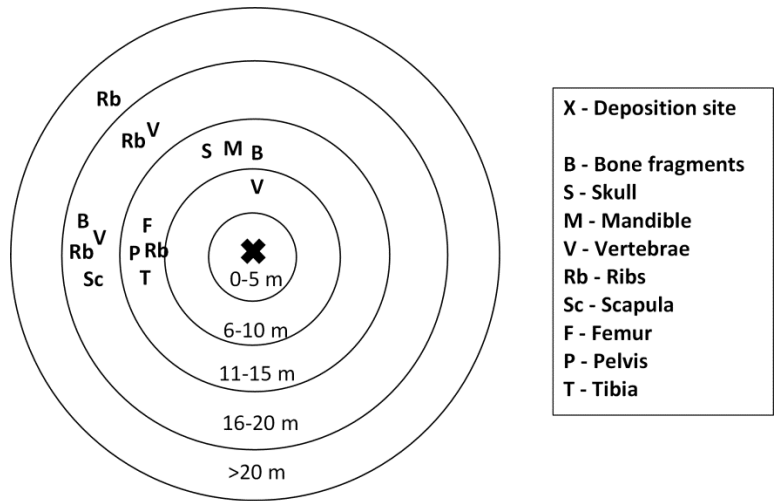

FIG. 4—Radial distribution diagram of skeletal elements at final collection for carcass 2-2, heavily fed on in early decomposition by *C. latrans* and *D. virginiana*. Winter season.

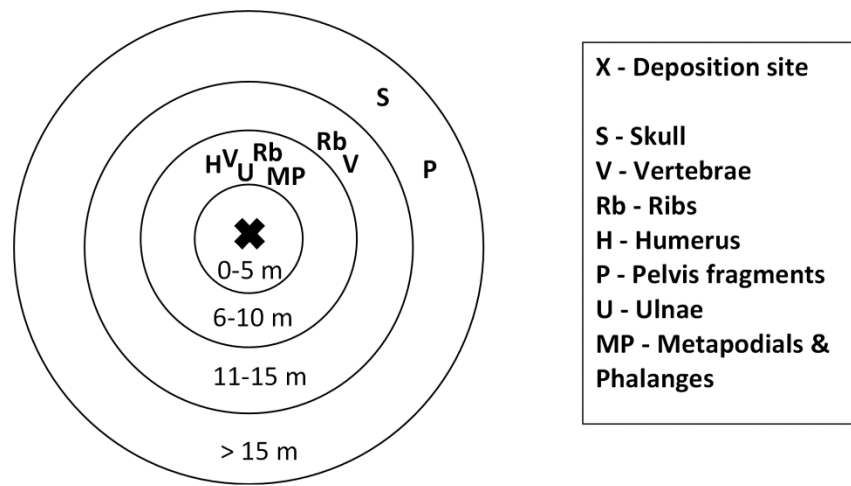

FIG. 5—Radial distribution diagram of skeletal elements at final collection for carcass 2-3, heavily fed on by *C. latrans* and *D. virginiana* in early decomposition. Winter season.

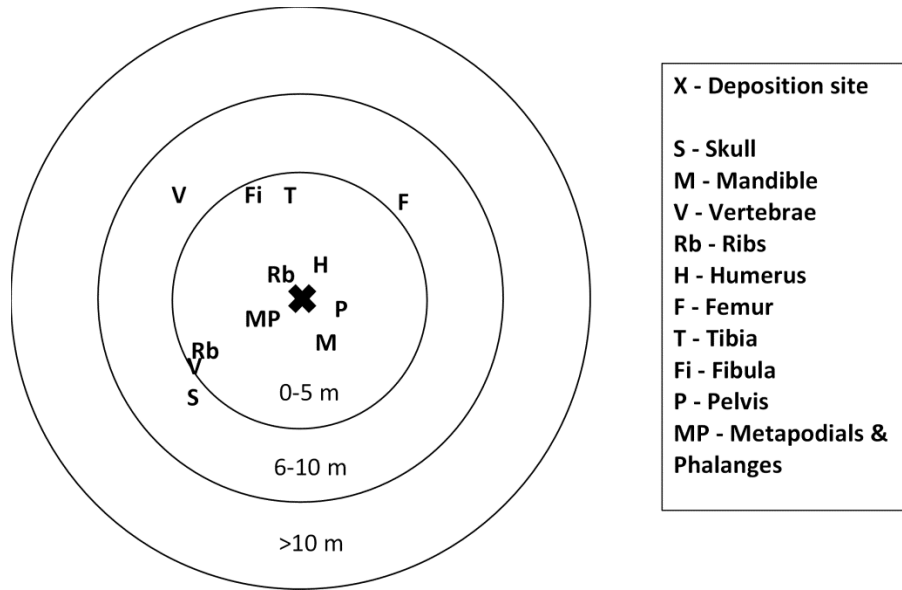

FIG. 6—Radial distribution diagram of skeletal elements at final collection for carcass 3, not scavenged until skeletonization/mummification by *C. latrans*. Summer season.

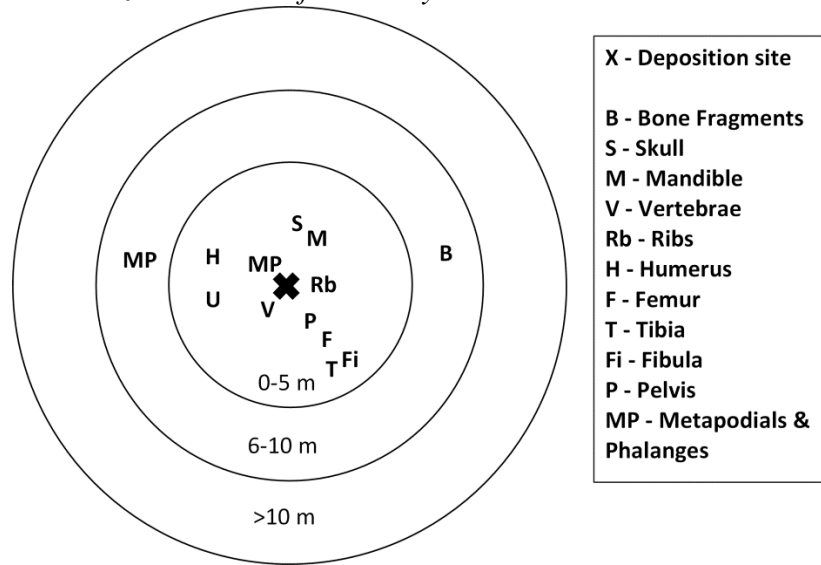

FIG. 7—Radial distribution diagram of skeletal elements at final collection for carcass 3-1, scavenged only by *D. virginiana*. Summer season.

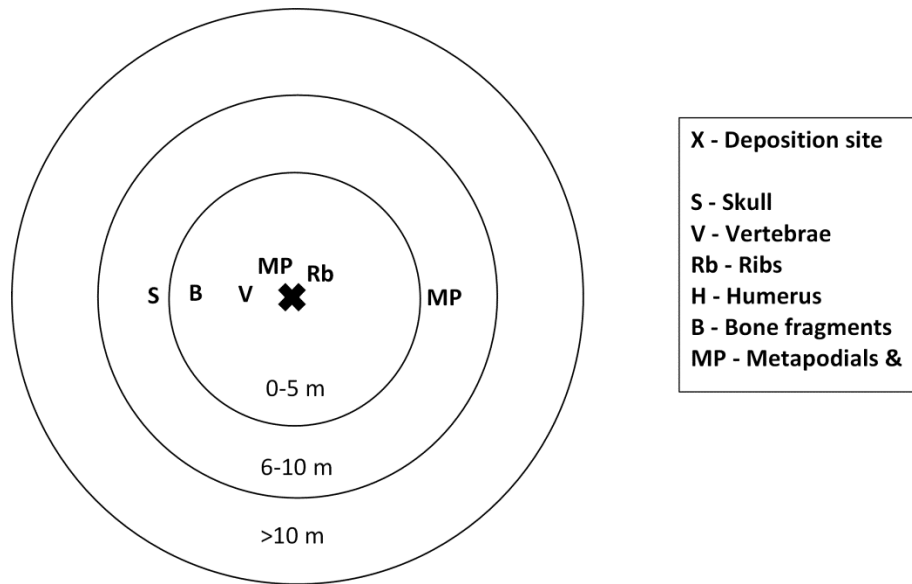

FIG. 8—Radial distribution diagram of skeletal elements at final collection for carcass 3-2, not scavenged until skeletonization/mummification by *C. latrans*. Summer season.

The most complete and least scattered carcass was not scavenged by coyotes (carcass 3-1). Other carcasses heavily used by coyotes, had few elements which were recovered (Table 1). Carcasses were highly incomplete and many diagnostic elements and features were missing. Thorough searches with both experienced searchers and students were undertaken, unrecovered elements were believed to have been ingested or otherwise fragmented and destroyed.

TABLE 1—*Skeletal elements collected at end of study from each carcass*

<b>Skeletal Element</b>	<b>1-1</b>	<b>1-2</b>	<b>1-3</b>	<b>2-2</b>	<b>2-3</b>	<b>3</b>	<b>3-1</b>	<b>3-2</b>	<b>3-3</b>
<b>Crania</b>	X*			X	X*	X	X*	X*	
<b>Mandible</b>	X	X		X		X			
<b>Clavicles</b>									
<b>Scapulae</b>	1			1					
<b>Humeri</b>					1	1	1		
<b>Ulnae</b>					2		1		
<b>Radii</b>									
<b>Ribs</b>	4*			24*	14*	10*	27*	6*	
<b>Vertebrae</b>	2*			13*	11*	18*	19*	4*	
<b>Manubrium</b>				1			3		
<b>Pelvis</b>	X*					X*	X*		
<b>Femora</b>						1	1		
<b>Tibiae</b>				1		1	1		
<b>Fibulae</b>					1	1	1		
<b>Epiphyses</b>				4	3	4	4	1	
<b>Podials</b>									3*
<b>Metapodials</b>					3*	3*			2*
<b>Phalanges</b>					4	6			9
<b>Hooves</b>					1				

*X indicates presence of a single element, the number given indicates number collected where there are more than one possible element*

*\* indicates fragmentary condition of elements, elements exhibiting less than one half their total proportion considered fragmentary*

## **Discussion**

Coyotes are a highly effective and successful species in metropolitan and other semi-urban areas encroached upon by humans. They are capable of maintaining territories in landscapes with minimal natural areas and elevated human activity, even within large cities and metropolitan areas (20). This gives them important forensic significance, as they inhabit the same natural areas in urban and semi-urban environments that are often the site for disposal of clandestine remains. They are highly prone to scavenging (21) and have the potential to greatly impact the scatter and destruction of human remains. The results of this study show the extent to which this occurs in a human analogue, the domestic pig.

Varying aspects of coyote scavenging behavior, such as caching, influence to a large degree the area of dispersal and the number of skeletal elements damaged and destroyed. Caching in this study was seen to a small degree, with only two hind limbs being moved considerable distances to confirmed cache sites. It is hypothesized that this is a result of the lack of a large pack of coyotes on the preserve. Caching behavior is less common among solitary coyotes (21). Video evidence suggested that no more than two coyotes were present at the carcasses at one time. There might also be seasonal variation in caching behavior. The instances of confirmed caching occurred in fall and winter in the colder part of the year. In fact one hind limb was dismembered and cached during a small snow storm, indicating weather may have been a factor in the decision to move the resource rather than ingest it in situ.

The dispersals of recoverable skeletal elements which were not cached were well within manageable search bounds. The maximum ranges of dispersal of remains, not including the transmitter outliers, are relatively small. Most recoverable elements were found within a 20 m radius of the original deposition site. This is a similar area of scatter to that of other observed



dispersals which peaked at distances of around a 20 m radius (15) and 84m<sup>2</sup> total areas (12). This implies a manageable area for searches of scavenged remains, once an initial skeletal element(s) is located.

While the utilization of radio telemetry transmitters showed distances elements could be moved to caches, they also revealed that bones taken to these caches were ingested and not left intact. Bones found with trackers were highly fragmented and had no diagnostic physical features. These bone fragments were barely a centimeter in size. They were highly degraded and were missing the periosteum, likely making them unsuitable for DNA analysis. Movement of these elements was typically toward the north and east and away from areas of human activity. Cache sites were often at brush piles along established game trails. Elements were often moved along game trails and towards natural cover away from human activity which is similar to what has been reported in other research (11).

There was an enormous paucity of diagnostically significant elements which were collectable at the end of the experiment. Diagnostic areas of the pelvis, such as the pubic symphysis were rarely collected. At most, only half of the dentition was collected (Table 2). Many of these teeth were broken and damaged. Domestic pigs have more teeth than humans, suggesting that even less might be recoverable when dealing with human remains.

TABLE 2 —*Dentition collected from carcasses at time of collection of skeletal elements.*

<b>Tooth</b>	<b>1-1</b>	<b>1-2</b>	<b>2-2</b>	<b>2-3</b>	<b>3-1</b>	<b>3-2</b>	<b>Intact Pig</b>
<b>Incisor</b>	6 E (2 B)	5 E (2 B)	2 E	----- -----	2 E	----- -----	12
<b>Canine</b>	----- -----	1 U	4 E (4 B)	2 E (2 B)	----- -----	----- -----	4
<b>Premolar</b>	3 E	1 E (B)	9 E	4 E	4 E	1 E 1 U	16
<b>Molar</b>	2 E 2 U	2 E (1 B)	9 E 2 U	6 E 2 U	2 E 2 U	2 E 1 U	12
<b>Total #</b>	13	9	24	14	10	5	44

*E indicates erupted*

*U indicates un-erupted*

*B indicates the tooth was broken*

The large number of missing elements observed at smaller carcasses supports previous studies of scavenging on child size remains (15). Smaller, younger carcasses have more protein rich red marrow, along with less hard dense bone, than that seen in older carcasses. These areas may be heavily targeted, which may account for the widespread destruction of elements seen in this study. Targeting of marrow rich areas has been previously noted (22). This difference may also account for the small areas of dispersal of the remains. The dispersals of even the larger carcasses in this study, most likely mimic child size remains rather than adults due to the lack of fused bones. Large, heavy, fully developed bones might be more difficult and time consuming to ingest in situ and may be more likely to be cached. Using larger pigs however, would result in a muscle-fat-size ratio that is dissimilar to humans, especially in fully adult pigs which can weigh more than 200 kg. Cadaver research is necessary to more fully understand how adult human

remains would be disburied or cached. Some indications of these differences though, can be derived from these results.

For example, carcasses in this study were disarticulated in a different sequence than that identified by Haglund, Reay and Swindler (2) for scavenged human remains from case studies. In their research, remains were fed upon beginning with the face, throat and thorax, followed by the disarticulation of the upper limbs. In this study, disarticulation began with the lower limbs and pelvis. Similarly, there was a difference in what remained at the original deposition site. In their research, skulls, ribs, and vertebrae tended to be at or near the original deposition site. Here, only three of the nine carcasses displayed this pattern. These differences might reflect the unique decompositional traits of swine integument. No skin slippage was noted throughout the decomposition of the carcasses during this study, including the controls. The skin mummified and became a thick leathery hide that kept elements bound together. To loosen this hide and retrieve skeletal elements, coyotes had to forcibly pull and tear at the carcasses, dragging them around the area. While a clear linear pattern of dispersal has been reported in human remains scavenging, in this study it was generally radial. This resulted in a small maximum distance of scatter, containing most of the recoverable elements in an area of under a 20 m radius.

Also in contrast to previous human case studies, not all crania were recovered. In a survey of scavenged human remains, 100% of crania were collected with minimal damage (1). In this study, only two fully intact skulls, and one nearly intact skull, were collected. The others were reduced to small fragments or were completely destroyed. This may again be an artifact of using pigs as human analogues. The shape of pig skulls are different than that of humans and are more conducive to being held in the jaws of mammalian scavengers, as they are not round. They have a prognathic snout which allows for more areas to grab. The pigs utilized in this study were

young, ranging between 10-16 weeks old. Unfused cranial sutures promoted the fragmentation of the skulls and facilitated easier ingestion of the cranial tissues.

Similar taphonomic patterns which have been attributed to canid scavenging (1) were observed in recovered skeletal elements. Those elements most affected by coyote scavenging were the pelvis, long bones, ribs, and vertebrae. Characteristic gnawing of ends of ribs, as well as, the spinous and transverse processes of vertebrae were observed. The borders of the scapula and ilium had substantial tooth mark defects. These defects were similar to the pits, punctures, and furrowing observed by Patel (23). However, V-shaped scratches and linear abrasions identified by Haglund (1), which are typically caused by carnivores gaining leverage on bones with their claws, were not present to any extent. Tooth mark defects of coyotes can be distinguished from that of other scavengers, such as opossums. These taphonomic differences have been discussed elsewhere (24).

## **Conclusions**

Understanding dispersal patterns and distances of remains scatter caused by scavenging behaviors of large mammalian predators such as the coyote in metropolitan and semi-urban areas is important to forensic death investigations. The results of this study suggest that in these environments, coyote scavenging can have significant taphonomic impact on the condition and recoverability of remains, particularly child sized remains. Large numbers of skeletal elements, many diagnostically important, were consumed within a short period of time. Several carcasses were completely consumed in only a few days. While some caching was observed, the majority of recoverable elements were dispersed in less than a 20 m radius. This pattern might change in other environments or where large packs are present. There is evidence to suggest that this

pattern might also not be comparable to scavenging of adult sized human remains. Further research using cadavers is necessary.

### *Acknowledgements*

We are grateful to the Oklahoma Department of Wildlife Conservation, especially Daniel Griffith and Damon Springer for providing access to the research site. We are also appreciative of Kimberly Watson and Amy Waters for aiding in searches and collections that were essential to this project.

### **References**

1. Haglund, WD, Reay, DT, Swindler, DR. Tooth mark artifacts and survival of bones in animal scavenged human skeletons. *Journal of Forensic Sciences* 1988 33(4):985-997.
2. Haglund, WD, Reay, DT, Swindler, DR. Canid scavenging/disarticulation sequence of human remains in the Pacific Northwest. *Journal of Forensic Sciences* 1989 34(3): 587-606.
3. Wiley, P, Snyder, LM. Canid modification of human remains: Implications for time-since-death estimations. *Journal of Forensic Sciences* 1989 34(4): 894-901.
4. Haglund, WD. Contribution of rodents to postmortem artifacts of bone and soft tissue. *Journal of Forensic Sciences* 1992 37(6): 1459-1465.
5. Pickering, TR. Carnivore voiding: a taphonomic process with potential for the deposition of forensic evidence. *Journal of Forensic Sciences* 2001 46(2): 406-411.
6. Klippel, WE, Synsteliën, JS. Rodents as taphonomic agents: Bone gnawing by brown rats and gray squirrels. *Journal of Forensic Science* 2007 52(4): 765-773.

7. Reeves, NM. Taphonomic effects of vulture scavenging. *Journal of Forensic Sciences* 2009 54(3): 523-528.
8. Càceres, I, Esteban-Nadal, M, Bennasàr, M, Fernàndez-Jalvo, Y. Was it the deer or the fox? *Journal of Archaeological Science* 2011 38: 2767-2774.
9. Stiner, MC, Munro, ND, Sanz, M. Carcass damage and digested bones from mountain lions (*Felis concolor*): Implications for carcass persistence on landscapes as a function of prey age. *Journal of Archaeological Science* 2011 37(8): 896-907.
10. Haglund, WD, & Reay, DT. Problems of recovering partial human remains at different times and locations: Concerns for death investigators. *Journal of Forensic Sciences* 1993 38(1): 69-80.
11. Kjørliien, YP, Beattie, OB, Peterson, AE. Scavenging activity can produce predictable patterns in surface skeletal remains: Observations and comments from two experiments. *Forensic Science International* 2007 188: 103-106.
12. Spradley, MK, Hamilton, MD, Giordano, A. Spatial patterning of culture scavenged human remains. *Forensic Science International* 2012 219: 57-6.
13. Koehler, GM, Hornocker, MG. Seasonal resource use among mountain lions, bobcats, and coyotes. *Journal of Mammology* 1991 72(2).
14. Disney, MR. Relative abundance of mesopredators and size of oak patches in the cross-timbers ecoregion. *The Southwest Naturalist* 2008 53(2): 214-223.
15. Morton, RJ, Lord, WD. Taphonomy of child-sized remains: A study of scattering and scavenging in Virginia, USA. *Journal of Forensic Sciences* 2006 51(3): 475-479.

16. O'Brien, RC, Forbes, SL, Meyer, J, Dadour, IR. A preliminary investigation into the scavenging activity on pig carcasses in Western Australia. *Forensic Science, Medicine, and Pathology* 2007 3:194-199.
17. O'Brien, RC, Forbes, SL, Meyer, J, Dadour, IR. Forensically significant scavenging guilds in the southwest of Western Australia. *Forensic Science International* 2010 198: 85-91.
18. Calce, SE, Rogers, TL. Taphonomic changes to blunt force trauma: A preliminary study. *Journal of Forensic Sciences*, 2007 52(3), 519-527.
19. Schotsmans, EM, et al. Effects of hydrated lime and quicklime on the decay of buried human remains using pig cadavers as human body analogues. *Forensic Science International* 2011 217(1-3): 50-59.
20. Gehrt, SD, Anchor, C, White, LA. Home range and landscape use of coyotes in metropolitan landscape: conflict or coexistence? *Journal of Mammalogy*, 2009 90(5), 1045-1057.
21. Atwood, TC, Gese, EM. Importance of resource selection and social behavior to partitioning of hostile space by sympatric canids. *Journal of Mammalogy*, 2010 91(2), 490-499.
22. Klippel, WE, Synstelien, JS. Rodents as taphonomic agents: bone gnawing by brown rats and gray squirrels. *Journal of Forensic Sciences*, 2007 52(4), 765-773.
23. Patel, F, Path, MRC. Artefact in forensic medicine: postmortem rodent activity. *Journal of Forensic Sciences*, 1994 46(2), 406-411.

24. King, K.A. Relocation of remains: scavenger scatter patterns in central Oklahoma.

Proceedings of the American Academy of Forensic Sciences Annual Meetings; 2014 Feb

17-22; Seattle, WA.



## **Chapter 6:**

### **Conclusions**

The necrophagus scavenging behaviors of the three mammalian vertebrate guild members in north central Oklahoma, the coyote (*C. latrans*), the Virginia opossum (*D. virginiana*), and the bobcat (*L. rufus*), observed in this study have significant implications for forensic death investigations. Each animal participated in unique behaviors that produce equally unique taphonomic features which can inform estimations of time since deposition and post-mortem interval. These behaviors also result in particular dispersal patterns, which are relative to searches for remains.

Scavenging behaviors of the opossum might be the most forensically relevant observations to come from this study. The opossum used natural body orifices and tears caused by decomposition to access carcass tissues. This behavior resulted in no movement of the carcasses until they had been reduced to integument and bone. The opossum removed internal tissues first and then worked to decomposing muscle and integument tissues of limbs. They did not feed on bone until the final stages of decomposition. This feeding behavior resulted in the skeletonization of the carcass in less than half of the accumulated degree days (ADD) than that of a comparable control. This is significant to forensic death investigations. Using current suggested methods of total body score (TBS) combined with ADD to assess an estimate of deposition interval in this case yields high overestimates. This is important in terms of how death investigations are conducted. Using deposition interval estimates, particular missing persons and other potential possibilities are narrowed based on matching time frames. In cases of scavenged remains, especially if utilized by opossums, they may appear to have been exposed much longer than they actually were. This has the potential to lead to incorrect pools of potential victims, which may subsequently lead to wasted time and resources which are critical to successful resolutions of cases.

The dispersal of remains was caused mostly by the scavenging activity of coyotes. Carcasses were drug from their original deposition positions as coyotes attempted to remove limbs for consumption. Coyotes tended to feed on the hind limbs of the carcasses first, removing muscle tissue from the calf area covering the tibia, then the thigh, and then the buttocks and pelvic region. Tibias and femurs were shattered and the marrow consumed. Large quantities of skeletal elements were consumed by these canids, especially the bones of the pelvis, which are the most useful for diagnostic assessment.

Several long bones were moved considerable distances to cache sites, but the majority of scatter was within a small 20-25 m radius. Elements recovered within these areas were typically ribs, vertebra, podials, and metapodials. A large number of teeth were broken, consumed, or lost. Very few elements recovered showed no signs of scavenging. Most had characteristic bite marks or gnawing. Bite marks of coyotes could be differentiated from those of opossums based on size and shape. There was also a difference in the biomechanics of the way the two species chewed on bones which resulted in distinct patterns of bone breakage and splintering. Coyote gnawing left squared broken edges. In contrast, opossum chewing resulted in splintered and frayed ends. It is important to note that coyotes fed on bones at all stages of decomposition except for the initial fresh stage. Opossum bone defects were not seen until the very latest stages. This has significant implications for determining post-deposition time frames. Characteristic bone damage of the opossum if seen on scavenged remains would indicate a longer deposition interval, than that of bone damage of a coyote alone.

Scavenging by bobcats did not leave any taphonomic defects on skeletal elements. Bobcats fed solely on muscle, fat, and integument. Bobcats also only fed in the early fresh stages of decomposition with no insect activity. Feeding by the bobcats did leave characteristic marks

in soft tissue, however. There were clear tears from the felines' claws, where they hooked into the carcass for leverage. There were also clear bite marks on the edges of integument at areas where the tissues had been consumed. The bobcats consumed carcasses in a manner different from both the coyotes and opossums, focusing their feeding on the upper torso, neck, and arm areas. The bobcats were also observed covering the carcass in a telltale way. These indicators might be of forensic significance in terms of being able to identify that scavenging has occurred by a bobcat and not a coyote. More importantly bobcats only scavenged in the early fresh stages, so that if indicators of bobcat scavenging are present, a very short deposition interval is highly probable.

The observations of bobcats scavenging are more important ecologically as bobcats are not considered to be highly active scavengers like coyotes. This study represents the first time that a female bobcat and cub were observed to scavenge heavily and for durations of multiple days on experimentally placed carcasses. Previously, scavenging behavior of bobcats has been inferred from stomach contents analysis, and has not been directly observed. Scavenging by bobcats may be influenced by encroachment of humans and fragmentation of habitat. Other mesopredators and medium sized vertebrate scavengers such as the opossum and raccoon are observed to become heavier scavengers in these types of environments. It is likely that the same thing is occurring in bobcats as resources and habitats become pressed. The bobcat may then become a more prominent member of the scavenger guild as seen here, increasing their forensic significance as they become increasingly likely to come into contact with disposed remains. The bobcats in this study did not appear to be discouraged by human scent, or repeated visits to the area, indicating that they would not be deterred by these factors which typically accompany

clandestine remains. A bobcat has been observed feeding on experimentally placed human remains (Ripley et al., 2012), further indicating this potential.

### **Future Research**

The results of this study, while compelling, cannot necessarily be extrapolated to other regions, even if similar ecologically. The nature of the preserve itself, being bordered to the north by a lake and in the other directions by housing, may influence the behaviors of these animals. This research needs to be repeated at several other locations.

The caching behavior of these coyotes may also be dissimilar to that of coyotes in general. Cache sites need to be identified and monitored long term to determine what amount of resources are being cached in general, how long they persist at these sites, how many cache sites there are, and how these sites are dispersed within coyote territories.

Several forensically relevant observations were made that are not directly related to scavenging behavior, which were outside the scope of this study, but warrant further investigation. There was a strong differential in vegetation growth at deposition sites where carcasses laid leaking decompositional fluid. Dark stains were formed, and vegetation died where the carcass had lain. However, vegetation at the edges of the stains thrived well beyond that of the surrounding area. This difference in many cases persisted for months. This occurrence has the potential to inform many aspects of forensic death investigations such as time since deposition, direction of movement from the deposition site, and size and condition of the remains at deposition. There were two particular species that showed a large differential in growth and color at the edges of decomposition stains, *Bromus tectorum* and *Achilleas lanulosa*. Further

research is needed to determine if these are good indicator species for remains deposition or grave sites.

There is also a drastic drop off in scavenger activity when insect colonization is at its peak. A substance was created by maggot masses at the carcasses which persisted long after the mass was gone. This substance rehydrated with precipitation and had a distinct foul smell. Scavenger activity decreased when this substance was rehydrated as well. Further analysis is needed to understand if this is a toxin, and how exactly it is deterring vertebrate feeding activity.

## References

- Adlam, R. E. & Simmons, T. (2007). The effect of repeated physical disturbance on soft tissue decomposition - Are taphonomic studies an accurate reflection of decomposition? *Journal of Forensic Sciences*, 52 (5), 1007-1014.
- Asamura, H., Takayanagi, K., Ota, M., Kobayashi, K., & Fukushima, H. (2004). Unusual characteristic patterns of postmortem injuries. *Journal of Forensic Sciences*, 49(3), 1-3.
- Atwood, T.C., & Gese, E.M. (2010). Importance of resource selection and social behavior to partitioning of hostile space by sympatric canids. *Journal of Mammalogy*, 91(2), 490-499.
- Aturaliya, S., & Lukasewycz, A. (1999). Experimental forensic and bioanthropological aspects of soft tissue taphonomy: Factors influencing postmortem tissue desiccation rate. *Journal of Forensic Sciences*, 44(5), 893-896.
- Bachman, J., & Simmons, T. (2010). The influence of preburial insect access on the decomposition rate. *Journal of Forensic Sciences*, 55(5), 893-900.
- Behrensmeier, A.K. (1978). Taphonomic and ecologic information from bone weathering. *Paleobiology*, 4 (2), 150-162.
- Bell, L. S., Skinner, M. F., & Jones, S. J. (1996). The speed of post mortem change to the human skeleton and its taphonomic significance. *Forensic Science International*, 82, 129-140.
- Berg, A.K. (January 19, 2012). Personal communication. Anthropologist/Unidentified case management; Office of the Chief Medical Examiner, Oklahoma.
- Binford, L. R. (1999). Forces that shaped the past: Origins of the new archaeology. *Archaeology*, 52(1), 54.
- Brockmeyer, K.J., & Clark, W.R. (2007). Fall and winter food habits of bobcats (*Lynx rufus*) in Iowa. *Journal of the Iowa Academy of Sciences*, 114(1,4), 40-43.



- Càceres, I., Esteban-Nadal, M., Bennasàr, M., & Fernàndez-Jalvo, Y. (2011). Was it the deer or the fox? *Journal of Archaeological Science*, *38*, 2767-2774.
- Calce, S. E., & Rogers, T. L. (2007). Taphonomic changes to blunt force trauma: A preliminary study. *Journal of Forensic Sciences*, *52*(3), 519-527.
- Campobasso, C.P., Di Vella, G., Introna, F. (2001). Factors affecting decomposition and Diptera colonization. *Forensic Science International*, *120*, 18-27.
- Chamberlin, M.J., & Leopold, B.D. (2005). Overlap in space use among bobcats (*Lynx rufus*), coyotes (*Canis latrans*), and gray foxes (*Urocyon cinereoargenteus*). *American Midland Naturalist*, *153*, 171-179.
- Columbia Law Review (1961). Murder conviction upheld despite lack of direct evidence of *corpus delicti*. *Columbia Law Review*, *61*(4), 740-744
- Cortes-Avizanda, A., Carrete, M., Serrano, D., & Donazar, J. A. (2009). Carcasses increase the probability of predation of ground-nesting birds: A caveat regarding the conservation value of vulture restaurants. *Animal Conservation*, *12*, 85-88.
- Delabarde, T., & Ludes, B. (2010). Missing in Amazonian jungle: A case report of skeletal evidence for dismemberment. *Journal of Forensic Sciences*, *55*(4), 1105-1110.
- Denys, C. (2002). Taphonomy and experimentation. *Archaeometry*, *44*(3), 469-484.
- DeVault, T. L., Brisbin, I. L., & Rhodes, J. O. (2004). Factors influencing the acquisition of rodent carrion by vertebrate scavengers and decomposers. *Canadian Journal of Zoology*, *82*, 502-509.
- DeVault, T.L., Olson, A.H., Beasley, J.C., & Rhodes, O.E.. 2011. Mesopredators dominate competition for carrion in an agricultural landscape. *Basic and Applied Ecology*, *12*, 268-274.

- Disney, M.R., Hellgren, E.C., Davis, C.A., Leslie, D.M., & Engle, D.M. (2008). Relative abundance of mesopredators and size of oak patches in the cross-timbers ecoregion. *The Southwest Naturalist*, 53(2), 214-223.
- Gehrt, S. D., Anchor, C., & White, L. A. (2009). Home range and landscape use of coyotes in metropolitan landscape: conflict or coexistence? *Journal of Mammalogy*, 90(5), 1045-1057.
- Gruenthal, A., Moffatt, A., & Simmons, T. (2011). Differential decomposition patterns in charred versus un-charred remains. *Journal of Forensic Sciences*, 1-7.
- Gwinn, R.N., Palmer, G.H., & Koprowski, J.L. (2011). Virginai opossum (*Didelphis virginiana*) from Yavapi County, Arizona. *Western North American Naturalist*, 71(1), 113-114.
- Haglund, W. D. (1992). Contribution of rodents to postmortem artifacts of bone and soft tissue. *Journal of Forensic Sciences*, 37(6), 1459-1465.
- Haglund, W.D., & Reay, D.T. (1993). Problems of recovering partial human remains at different times and locations: Concerns for death investigators. *Journal of Forensic Sciences*, 38(1), 69-80.
- Haglund, W.D., Reay, D.T., & Swindler, D.R. (1988). Tooth mark artifacts and survival of bones in animal scavenged human skeletons. *Journal of Forensic Sciences*, 33(4), 985-997.
- Haglund, W.D., Reay, D.T., & Swindler, D.R. (1989). Canid scavenging/disarticulation sequence of human remains in the Pacific Northwest. *Journal of Forensic Sciences*, 34(3), 587-606.
- Huculak, M.A. & Rogers, T.L. (2009). Reconstructing the sequence of events surrounding body disposition based on color staining of bone. *Journal of Forensic Sciences*, 54 (5), 979-984.

- Janečka, J.E., Blankenship, T.L., Hirth, D.H., Tewes, M.E., Kilpatrick, C.W., & Grassman, L.I. (2006). Kinship and social structure of bobcats (*Lynx rufus*) inferred from microsatellite and radio-telemetry data. *Journal of Zoology*, 269, 494-501.
- Karr, L. P., & Outram, A. K. (2012). Tracking changes in bone fracture morphology over time: Environment, taphonomy, and the archaeological record. *Journal of Archaeological Science*, 39, 555-559.
- Kjorlien, Y. P., Beattie, O. B., & Peterson, A. E. (2009). Scavenging activity can produce predictable patterns in surface skeletal remains: Observations and comments from two experiments. *Forensic Science International*, 188, 103-106.
- Klippel, W. E., & Synsteliën, J. S. (2007). Rodents as taphonomic agents: Bone gnawing by brown rats and gray squirrels. *Journal of Forensic Sciences*, 52(4), 765-773.
- Koehler, G.M., & Hornocker, M.G. (1991). Seasonal resource use among mountain lions, bobcats, and coyotes. *Journal of Mammalogy*, 72(2).
- Lariviere, S., & Walton, L.R. (1997). *Lynx rufus*. *Mammalian Species*, 563, 1-8.
- MacAulay, L. E., Barr, D.G. & Strongman, D.B. (2009). Effects of decomposition on gunshot wound characteristics: Under cold temperatures with no insect activity. *Journal of Forensic Sciences*, 54 (2), 448-451.
- Mann, R.W., Bass, W.M., & Meadows, L. (1990). Time since death and decomposition of the human body: Variables and observations in case and experimental field studies. *Journal of Forensic Sciences*, 35(1), 103-111.
- McManus, J.J. (1974). *Didelphis virginiana*. *Mammalian Species*, 40, 1-6.
- Menez, L. L. (2005). The place of a forensic archaeologist at a crime scene involving a buried body. *Forensic Science International*, 152, 311-315.

- Megyesi, M. S., Nawrocki, S. P., & Haskell, N. H. (2005). Using accumulated degree days to estimate the postmortem interval from decomposed human remains. *Journal of Forensic Sciences*, 50(3), 618-626.
- Morton, R. J., & Lord, W. D. (2006). Taphonomy of child-sized remains: A study of scattering and scavenging in Virginia, USA. *Journal of Forensic Sciences*, 51(3), 475-479.
- Moses, R.J. (2012). Experimental adipocere formation: Implications for adipocere formation on buried bone. *Journal of Forensic Sciences*, 57, 589-595.
- O'Brien, R. C., Forbes, S. L., Meyer, J., & Dadour, I. R. (2007). A preliminary investigation into the scavenging activity on pig carcasses in Western Australia. *Forensic Science, Medicine, and Pathology*, 3, 194-199.
- O'Brien, R. C., Forbes, S.L., Meyer J., & Dadour, I. (2010). Forensically significant scavenging guilds in the southwest of Western Australia. *Forensic Science International*, 198, 85-91.
- Olsen, S.L. & Shipman, P. (1988). Surface modification on bone: trampling versus butchery. *Journal of Archaeological Science*, 15, 535-553.
- Ordeñana, M.A., et al. (2010). Effects of urbanization on carnivore species distribution and richness. *Journal of Mammalogy*, 91(6), 1322-1331.
- Ortner D.J. (2003). *Identification of pathological conditions in human skeletal remains*. 2<sup>nd</sup> ed. San Diego CA: Academic Press.
- Parks, C. L. (2011). A study of the human decomposition sequence in central Texas. *Journal of Forensic Sciences*, 56(1), 19-22.
- Patel, F. & Path, M.R.C. (1994). Artefact in forensic medicine: postmortem rodent activity. *Journal of Forensic Sciences*, 39(1), 257-260.
- Pickering, T.R. (2001). Carnivore voiding: a taphonomic process with potential for the deposition

- of forensic evidence. *Journal of Forensic Sciences*, 46 (2), 406-411.
- Reeves, N. M. (2009). Taphonomic effects of vulture scavenging. *Journal of Forensic Sciences*, 54(3), 523-528.
- Ripley, A., Larison, N.C., Moss, K.E., Kelly, J.D., & Bytheway, J.A. (2012). Scavenging behavior of *Lynx rufus* on human remains during the winter months of southeast Texas. *Journal of Forensic Sciences*, 57(3), 699-705.
- Rodriguez, W. C., & Bass, W.M. (1982). Insect activity and its relationship to decay rates of human cadavers in East Tennessee. Master's thesis, University of Tennessee, Knoxville.
- Rolley, R.E. (1985). Dynamics of a harvested bobcat population in Oklahoma. *The Journal of Wildlife Management*, 49(2), 283-292.
- Rolley, R.E., & Warde, W.D. (1985). Bobcat habitat use in southeastern Oklahoma. *The Journal of Wildlife Management*, 49(4), 913-920.
- Schotsmans, E. M., et al. (2011). Effects of hydrated lime and quicklime on the decay of buried human remains using pig cadavers as human body analogues. *Forensic Science International*, 217(1-3), 50-59.
- Selva, N., et al. (2005). Factors affecting carcass use by a guild of scavengers in European temperate woodland. *Canadian Journal of Zoology*, 83, 1590-1601
- Sikes, R.S., Gannon, W.L., & the Animal Care and Use Committee of the American Society of Mammalogists. (2011). Guidelines of the American Society of Mammalogists for the use of wild mammals in research. *Journal of Mammalogy*, 92, 235-253.
- Spradley, M.K., Hamilton, M.D., & Giordano, A. (2012). Spatial patterning of culture scavenged human remains. *Forensic Science International*, 219, 57-63.
- Steele, G. & Bramblett, C. A. (1994). *The anatomy and biology of the human skeleton*. College

- Station, TX: Texas A&M University Press.
- Steadman, D. W. & Worne, H. (2007). Canine scavenging of human remains in an indoor setting. *Forensic Science International*, 173, 78-82.
- Stiner, M. C., Munro, N.D. & Sanz, M. (2011). Carcass damage and digested bones from mountain lions (*Felis concolor*): Implications for carcass persistence on landscapes as a function of prey age. *Journal of Archaeological Science*, 37(8), 896-907
- Thomas, K., & Walling, W. (2011). Arcadia Reservoir 5 year management plan. Oklahoma Department of Wildlife Conservation Publications
- Thornton, D.H., Sunquist, M.E., & Main, M.B. 2004. Ecological separation within newly sympatric populations of coyotes and bobcats in south-central Florida. *Journal of Mammalogy*, 85(5), 973-982.
- United Nations Food and Agriculture Organization. (2014). <http://www.fao.org>
- Voss, S.C., Cook, D.F., & Dadour, I.R. (2011). Decomposition and insect succession of clothed and unclothed carcasses in Western Australia. *Forensic Science International*, 211, 67-75.
- White, T.D., & Folkens, P.A. (2005). *The human bone manual*. Burlington, MA: Academic Press.
- Wiley, P., & Snyder, L.M. (1989). Canid modification of human remains: Implications for time-since-death estimations. *Journal of Forensic Sciences*, 34(4), 894-901.

## **Photo Appendix**



**1-2 Day 1**



**1-2 Day 4, neck and shoulder region, bobcat feeding**



**1-2 Day 4, bobcat concealment**



**1-2 Day 4, close up of wounds caused by bobcat feeding**



**1-2 Day 4, bobcat concealment**



**1-2 Day 5, scavenged by bobcat, coyote and opossum**





**1-2 Day 6, bobcat, coyote, and opossum scavenging**



**1-2 Day 9, mandible, no tissue**



**1-2 Day 7, bobcat, coyote, and opossum scavenging**



**1-3 Day 1**



**1-2, Day 9, skull, no remaining tissue**



**1-3 Day 5, tibia and fibula with foot attached, coyote cache site**



**Bobcat returning to 1-2, late afternoon**



**Bobcat feeding, late morning**



**Bobcat feeding at 1-2, late afternoon**



**Bobcat feeding, late morning**



**Bobcat cub feeding, late morning**



**Bobcat pair at 1-2, late morning**



**2-2 Day 1**



**2-2 Day 43, advanced decay, scavenging by coyotes and opossums**



**2-2 Day 36, drag path visible, moved by coyotes**



**2-2 Day 54, advanced decay, scavenging by coyotes and opossum**



**2-2 Day 36, close up, advanced decay**



**2-2 Day 61, advanced decay, begin scatter by coyotes**



**2-2 Day 36, feeding on lower limbs by coyotes**



**2-2 Day 68, torso cluster, scavenged and scattered heavily**



**Coyote scavenging 2-2, day 57**



**2-3 Day 85**



**2-3 Day 2, moved 7 m north, leg removed by coyotes**



**6/10/13 Site flooding**



**2-3 Day 26, advanced decay**



**6/10/13 Site flooding**



**2-3 Day 61, foot moved by turkey vulture**



**2-3 Post flooding**



29.04 inHg — 4°C 05/05/13 06:39 AM CONTROL

**Opossum feeding at scattered bones**



28.59 inHg — 20°C 04/29/13 11:20 PM SLMGC1

**Opossum feeding at 2-3**



28.85 inHg — 9°C 05/09/13 06:47 AM CONTROL

**Coyote at 2-3 scattered elements**



**3 Day 3**



28.85 inHg — 9°C 05/09/13 06:49 AM CONTROL

**Coyote at 2-3 scattered elements**



**3 Day 7**

**Vegetation at 1-1 deposition site, 6 months**



**Path and vegetation 2-2, 3 months**



**Path and vegetation 2-2, 3 months**



**3 Day 21**



**3 Day 37**



**3 Day 49**



