

THE EFFECT OF LAKE DESTRATIFICATION ON
WATER QUALITY PARAMETERS

By

JAMES MATTHEW STEICHEN

Bachelor of Science

Oklahoma State University

Stillwater, Oklahoma

1970

Submitted to the Faculty of the Graduate College
of the Oklahoma State University
in partial fulfillment of the requirements
for the Degree of
DOCTOR OF PHILOSOPHY
July, 1974

Thesis
1974D
S 818e
cop. 2

MAR 14 1975

THE EFFECT OF LAKE DESTRATIFICATION ON
WATER QUALITY PARAMETERS

Thesis Approved:

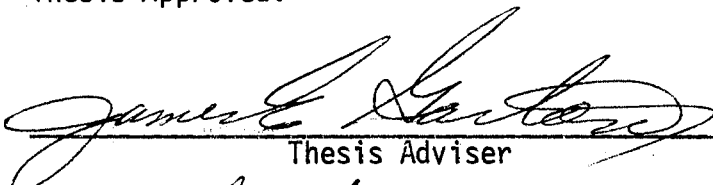
Thesis Adviser

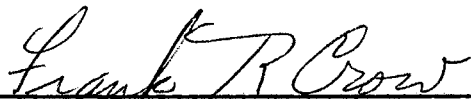



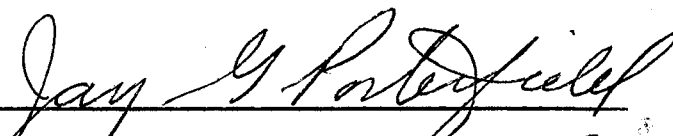



Dean of the Graduate College

902242

Name: James Matthew Steichen

Date of Degree: July, 1974

Institution: Oklahoma State University Location: Stillwater, Oklahoma

Title of Study: THE EFFECT OF LAKE DESTRATIFICATION ON WATER QUALITY
PARAMETERS

Pages in Study: 108

Candidate for: Degree of Doctor of Philosophy

Major Field: Agricultural Engineering

Scope and Method of Study: The objectives were: (1) Determine the effect of the pump's operation on the water quality parameters of a stratified lake; (2) Optimize design for minimum head loss, construct and evaluate a rigid diffuser for the lake destratification pump; and (3) Determine the relationships of shaft power, RPM and pump flow rate both with and without the diffuser.

The relationship between flow (Q) and power with a varying propeller RPM was determined both without a diffuser and with an optimum diffuser. The effect of the pump's operation on the lake was determined by observing: temperature, dissolved oxygen, alkalinity, pH, BOD₅, surface turbidity, and composite algae samples. The effect on fish was not observed.

Findings and Conclusions: The pump was capable of destratifying the lake without the diffuser attached. The destratification efficiency during this initial period of seven days was 6.0%. Fifteen days of operation were required to lower the stability to nearly zero. The destratification efficiency for this period was 4.6%. Destratification of all physical-chemical parameters was observed. A longer period of time is required to destratify DO then is necessary for thermal destratification. Although there were some changes in algae species predominating in the lake, there was no real shift from blue-green to green algae predominance. No significant improvement in diffuser efficiency was found in comparing the rigid metal diffuser with the flexible fabric diffuser. Using a propeller with greater pitch increased flow with the same power consumption. With a diffuser attached this pump was capable of moving 0.991 m³/sec from near the surface to near the lake bottom using 373 watts.

ADVISER'S APPROVAL

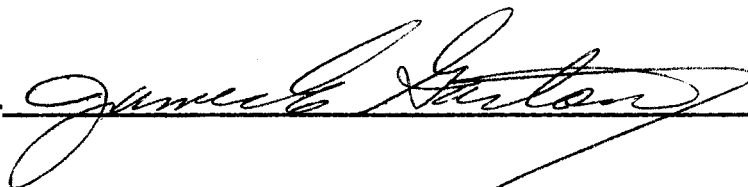

ACKNOWLEDGEMENTS

Many people and organizations have contributed to the successful completion of this project. The time, advice and friendly counsel of my major advisor, Dr. James Garton, is especially appreciated. Appreciation is also expressed to the other members of my committee: Professor E. W. Schroeder, Dr. Charles Rice, Professor Frank Crow, Dr. Richard DeVries and Professor Jay Porterfield. Advice in collecting and analyzing limnological data was given by Dr. Troy Dorris. Assistance in analyzing pump design was given by Dr. Peter Moretti.

My thanks is given to Jim Russell and the John Zink Foundation for permitting us to use Ham's Lake and its facilities. Jim's advice and cooperation were very helpful.

Dr. Jorge Quintero was the first to stimulate my interest in reservoir destratification. I appreciate his help and friendship.

I want to thank Clyde Skoch and Norvil Cole for their suggestions and cooperation. Appreciation is also extended to Jack Fryrear for the excellent preparation of illustrative material.

Funds for this project were provided in part by the Oklahoma Water Resources Research Institute. The support, interest and help of Mr. Howard Jarrell is acknowledged.

I deeply appreciate the encouragement and moral support given by my parents, Mr. and Mrs. John H. Steichen. Of course, I must mention the efforts of my wife Ethel. She is responsible for putting this

thesis in its final form. But more importantly, I thank her for the time, support and affection that has made my life rewarding.

TABLE OF CONTENTS

Chapter	Page
I. INTRODUCTION	1
Objectives.	3
Limitations of the Study.	3
II. REVIEW OF LITERATURE	5
Thermal Stratification.	5
Eutrophication.	9
Effects of Destratification	13
Methods of Artificial Destratification.	15
Compressed Air	16
Mechanical Pumping	17
Design of Rigid Diffuser.	18
III. EXPERIMENTAL EQUIPMENT	23
Pump.	23
Supporting Structure.	28
Platform.	28
Power Supply.	28
Measuring Devices	33
Location of Equipment	38
IV. METHODS AND PROCEDURE.	43
V. PRESENTATION AND ANALYSIS OF DATA.	46
Physical-Chemical	46
Temperature and Dissolved Oxygen	46
pH, CO ₂ and Alkalinity	59
BOD ₅	62
Specific Conductance	64
Turbidity.	64
Biological.	64
Analysis of Pump.	70
Pump Operation	70
Analysis of Pump Design.	71
Effectiveness of Pump.	75

Chapter	Page
VI. SUMMARY AND CONCLUSIONS.	77
Conclusions	77
Recommendations for Further Study	78
SELECTED BIBLIOGRAPHY	80
APPENDIX.	83

LIST OF TABLES

Table	Page
I. Diffuser Head Losses	27
II. Comparison of Various Destratification Efficiencies	76
III. Program for Calculating Stability Index	84
IV. Stability Index and Other Lake Parameters	86
V. Average Temperature Profiles	88
VI. Average Dissolved Oxygen Profiles	90
VII. Profiles of Alkalinity, pH, CO ₂ and Conductance	92
VIII. Profiles of BOD ₅	97
IX. Turbidity	98
X. Pump Data	99
XI. Plankton Counts	100

LIST OF FIGURES

Figure	Page
1. Typical Summer Thermal Stratification Pattern After Symons, J. M. (6)	7
2. Diagrammatic Representation of an Oligotrophic Lake, A, and an Eutrophic Lake, B. After Hutchinson, G. E. (7).	10
3. Temperatures for Selected Dates at One Place at Lake Arbuckle, Oklahoma. After Duffer, W. R. and C. C. Harlin, Jr. (8).	11
4. Dissolved Oxygen for Selected Dates at One Place at Lake Arbuckle, Oklahoma. After Duffer, W. R. and C. C. Harlin, Jr. (8).	12
5. Free Turbulent Jet Emerging from Submerged Nozzle into Large Volume of Miscible Fluid. The Expansion of, and Entrainment by, the Jet are Shown Diagrammati- cally. After Davies, J. T. (20)	19
6. Loss Coefficients for Conical Enlargements (22).	20
7. Diagram of Diffuser Terminating with a Sudden Enlargement. After Gibson, A. H. (21)	21
8. Assembly of Pump and Raft.	24
9. Pump Model	25
10. Propeller and Current Meter in Pump Casing	26
11. View of Casing	26
12. Exterior View of Diffuser.	29
13. Interior View of Diffuser.	30
14. Supporting Structure	31
15. Supporting Frame with Gimbals.	32
16. General View of Raft	32

Figure	Page
17. Results of Prony Brake Tests (3)	34
18. Measurement of Velocity.	35
19. Points Where Velocity was Measured in Pump Section	36
20. Power Measuring Instruments.	37
21. Measuring DO and Temperature Profiles with Electronic Monitor	39
22. Van Dorn Water Sampler	39
23. Area and Volume Curves for Ham's Lake.	40
24. Map of Ham's Lake.	41
25. Nomograph for Calculating CO ₂ from pH and Alkalinity	45
26. Typical Temperature Profiles	47
27. Plot of Temperature Versus Time for Readings Taken at the Seven Meter Depth at Various Locations	49
28. Plot of Temperature Versus Time at Pump.	50
29. Plot of Temperature Versus Time at Station A-East.	51
30. Plot of Temperature Versus Time at Station SW Neck	52
31. Typical Dissolved Oxygen Profiles.	54
32. Plot of Dissolved Oxygen Versus Time at Pump	55
33. Plot of Dissolved Oxygen Versus Time at Station A-East	56
34. Plots of Average Dissolved Oxygen, Average Temperature, and Stability Index Versus Time.	58
35. Typical pH Profiles.	60
36. Plots of BOD ₅ , pH and CO ₂ Versus Time at Station A-East.	61
37. Typical Biochemical Oxygen Demand Profiles	63
38. Specific Conductance Profiles.	65
39. Plot of Surface Turbidity Versus Time.	66
40. Plot of Plankton Counts Versus Time.	68

Figure	Page
41. Plot of Predominant Blue-Green Algae Counts Versus Time.	69
42. Flow Rate Versus Power Curves for Pump	72
43. Inlet Velocity Triangle for a Pump with Pre-Whirl.	74

CHAPTER I

INTRODUCTION

During late spring and early summer, the surface waters begin to warm, as atmospheric temperatures increase, and a strata of less dense water is formed above the cold bottom waters. As the surface strata (epilimnion) warms and is wind circulated, the thermocline or middle strata is developed and acts much as a diaphragm preventing surface-induced circulation below that depth. Since waters below the thermocline (hypolimnion) cannot be reoxygenated, they soon become void of oxygen by chemical reduction processes and biological respiration, forming a stagnant mass. As dissolved oxygen becomes depleted in hypolimnion waters, many deteriorating chemical reactions occur leaving the water mass high in hydrogen sulfide, phosphates, nitrates and various toxic metals (1).

Oligotrophic lakes do not exhibit anaerobic conditions in the hypolimnion and therefore the water quality is not degraded as much. Unfortunately, there are few oligotrophic lakes remaining. Most lakes are eutrophic to a greater or lesser degree.

Reservoirs and natural lakes constitute a major source of water supply for municipal, agricultural and other beneficial uses. Treatment is required for a municipal water supply. Much of the time the inlet structure will be located in the hypolimnion. This poorer quality water will often have taste and odor problems. The increased number of

impurities will raise the chlorine demand. The increased cost of treatment makes pre-treatment in the reservoir a possibility.

Hypolimnion releases often cause downstream fish kills and are annoying to people in the area breathing the toxic hydrogen sulfide gases released. Since the water is void or very low in dissolved oxygen, it is not useful for stream flow augmentation and high concentrations of undesirable chemical compounds may be released into the streams (1).

Stratification and its effects are one of the most studied areas of limnology. Because of interest in the adverse effects of stratification, efforts have been made to destratify reservoirs. Two major types of destratification devices have been used: mechanical pumping of hypolimnion water to the surface, and release of compressed air or oxygen near the bottom of a lake resulting in the movement and mixing of the water.

Most of these devices have been successful in destratifying lakes. Improvement in water quality including oxygenation of the lower waters has been observed. Unfortunately many of these devices were expensive to operate or experienced breakdowns allowing the lake to restratify.

A low-energy lake destratifier was developed by Quintero and Garton. This pump was capable of pumping 0.674 cubic meters per second using 373 watts. It was an axial flow pump that moved water from the epilimnion to the hypolimnion. This study involved only the mechanical aspects of the pump's operation. No data were collected on the effect of operation on the lake's parameters such as temperature or dissolved oxygen (2, 3).

Continued study of the Quintero and Garton destratification device is reported in this research. The pump was modified including the

design of a rigid diffuser to optimize the reduction of head loss. The effectiveness of the pump's operation on lake destratification was determined by observing various physical-chemical and biological parameters.

Objectives

1. Determine the effect of the pump's operation on the water quality parameters of a stratified lake.
2. Optimize design for minimum head loss, construct and evaluate a rigid diffuser for the lake destratification pump.
3. Determine the relationships of shaft power, RPM and pump flow rate both with and without the diffuser.

Limitations of the Study

Since a raft and pump frame had already been constructed by the department, this material was used. A 4.88 meter-long rigid diffuser was constructed. Sheet metal used for construction came in lengths of 2.44 meters and the depth of the lake made 4.88 meters a suitable length.

The maximum propeller RPM, and flow rates Q , were limited by the 373 watt electric motor used in the study.

A limit was made on the number of physical and chemical parameters investigated. Alkalinity, dissolved oxygen concentration, temperature, pH, conductivity and turbidity were measured. The only measurements involving biological factors were the five day biochemical oxygen demand (BOD₅) and the identification and quantification of composite

plankton samples. No attempt was made to study the effect of destratification on fish behavior or rate of growth.

CHAPTER II

REVIEW OF LITERATURE

Before attempting to destratify a body of water whose natural condition is stratified much of the year, an understanding of thermal stratification and its causes and effects is necessary.

Thermal Stratification

Hutchinson, in A Treatise on Limnology (4), describes the process by which a cool lake in the spring is transformed into a thermally stratified lake in the summer.

The heating of a lake in the temperate latitudes begins when the entire body of water is near 4° C., the temperature of maximum density. If such water were of uniform transparency and were quite undisturbed, radiation entering the water surface and being absorbed exponentially would heat the water at a rate falling exponentially from the surface, and so would produce an exponential temperature curve. Two principal factors prevent such a process from taking place or even being approached. First, evaporation will always cool the surface layer, setting up convection currents. These currents will be enhanced by back-radiation and loss of sensible heat, especially at night. Second, the lake surface will never be undisturbed by the wind setting up currents and turbulent motion leading to mixing and downward transport of momentum and heat.

The form of the resulting temperature distribution is exceedingly characteristic. In all lakes of sufficient depth, heating in the spring from a low temperature, the water tends to become divided into an upper region of more or less uniformly warm, circulating and fairly turbulent water termed the epilimnion, and a deep, cold and relatively undisturbed region termed the hypolimnion (4).

The zone of sharp temperature drop between these two regions is

termed the Sprungschicht in Germany; the thermocline in America and the discontinuity layer in England (5). The thermocline was defined by Birge as that layer in which the fall in temperature exceeds 1° C. per meter. Such a definition is quite arbitrary since in a warm lake a thermocline of less than 1° C. per meter could be stable. Hutchinson (4) suggests defining the thermocline as the plane of maximum rate of decrease in temperature, or in more formal terms the plane defined by:

$$\theta'' = \frac{d^2\theta}{dz^2} = 0 \quad (2-1)$$

The widely used term metalimnion is used to designate the whole of the region in which the temperature gradient is steep. Figure 1 illustrates the division of the three layers in a stratified lake.

The metalimnion is of special importance not only in the mechanics of currents and mixing, but also in connection with the biota in a lake. It divides the water mass into two regions characterized by fundamental differences. The epilimnion remaining under the influence of the atmosphere though the turbulent currents that are created by every wind is kept in motion, and any stratification set up in it can be only transitory. The individual water particles travel between the surface and the metalimnion through the many levels, as do also the passively floating forms, of which the phytoplankton are of particular interest. On the other hand, movements in the metalimnion and the hypolimnion--if they occur at all--occur predominately within the one level, permanent vertical translocations of water particles take place only to a minor degree. Above all, the metalimnion acts as a barrier between the upper and the lower regions and prevents contact of the hypolimnial water and of the organisms suspended in it (in so far as they are not capable of independent movement) with the surface, that is, with the air, and (when the depth is great enough) bars them from the use of light (5).

The more stable the stratification condition, the more energy that would be required to break it. The expenditure of energy necessary to upset an existing stratification or to bring it to a state where the whole water mass would have taken on the mean temperature by mixing is termed the stability of stratification. The idea of stability is

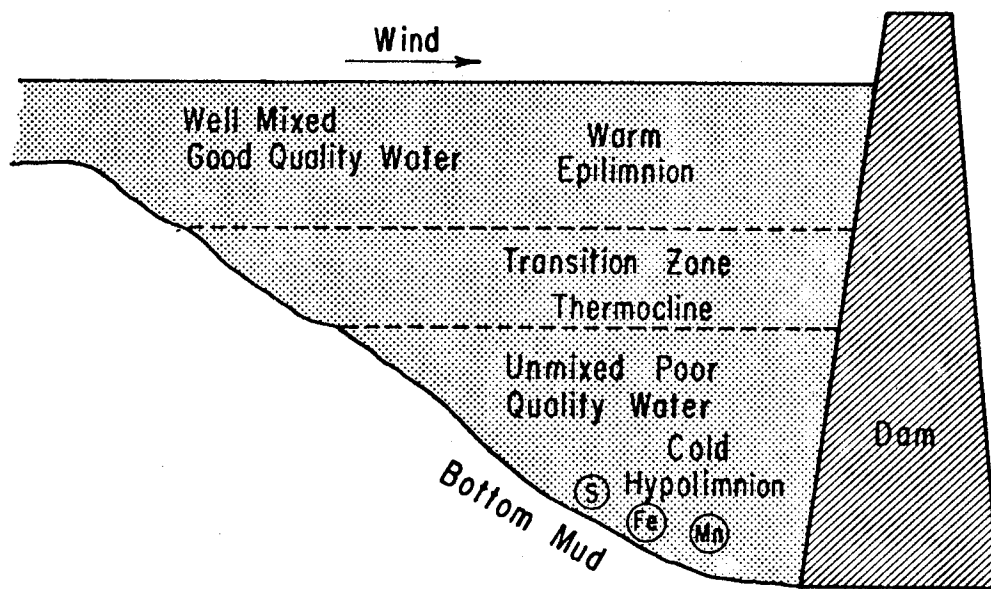

Figure 1. Typical Summer Thermal Stratification Pattern
After Symons, J. M. (6)

important since it gives a value for the resistance that a given state of stratification is able to oppose the stirring effect of the wind and thus also a value for the degree to which the hypolimnion of the lake is shut off.

Since the center of gravity of a stratified body of water lies lower than that of an unstratified one (because denser layers are below) Ruttner (5) defines stability as the work required to raise the center of gravity an amount corresponding to its displacement downward from its original position. This is equivalent to lifting the weight of the whole lake by a distance equal to the difference between the two centers of gravity.

A means of calculating the effectiveness of a destratification apparatus is suggested by Symons, et al. (6) Destratification efficiency (DE) is defined by the ratio:

$$DE = \frac{\text{Net change of stability from } t_1 \text{ to } t_2}{\text{Total energy input from } t_1 \text{ to } t_2} \times 100 \quad (2-2)$$

In their studies destratification efficiency values of from 0.2% with mechanical pumping to 1.5% using a diffused air pump were reported.

In the same study oxygenation capacity (OC) is defined by the ratio:

$$OC = \frac{\text{Net change in oxygen balance from } t_1 \text{ to } t_2}{\text{Total energy input from } t_1 \text{ to } t_2} \quad (2-3)$$

Values of oxygenation capacity ranged from 0.0% to 4.3%.

Eutrophication

During the past few years the word eutrophication has appeared in newspaper and magazine articles about the environment. It has usually been supposed to describe the process by which a beautiful lake or river becomes converted into a body of water covered with decomposing blue-green algae. The term was originally intended to mean the process of becoming well fed. The eutrophic lake has a large supply of necessary nutrients while the oligotrophic lake does not (7).

Eutrophication in combination with thermal stratification results in extreme consequences; the most notable of which is the loss of dissolved oxygen in the hypolimnion during the summer.

Figure 2 illustrates some of the differences between the oligotrophic lake (A) and the eutrophic lake (B). The curves give the typical late-summer temperatures and oxygen concentrations (O_2). The oligotrophic lake is generally deeper and even though it is thermally stratified, it does have much dissolved oxygen at all depths. The eutrophic lake is generally shallower and during stratification the hypolimnion will have little or no dissolved oxygen. Examples of actual temperature and oxygen curves from Lake Arbuckle in Oklahoma are given in Figures 3 and 4 (8).

One of the symptoms frequently used to distinguish the degree of the eutrophic state of a body of water is the algal standing crop. In oligotrophic lakes, there are relatively small standing crops of algae with a large diversity of genera. Highly eutrophic lakes generally have large quantities of algae and few genera. An algal "bloom" occurs when the number of algae per liter exceeds one half million (9).

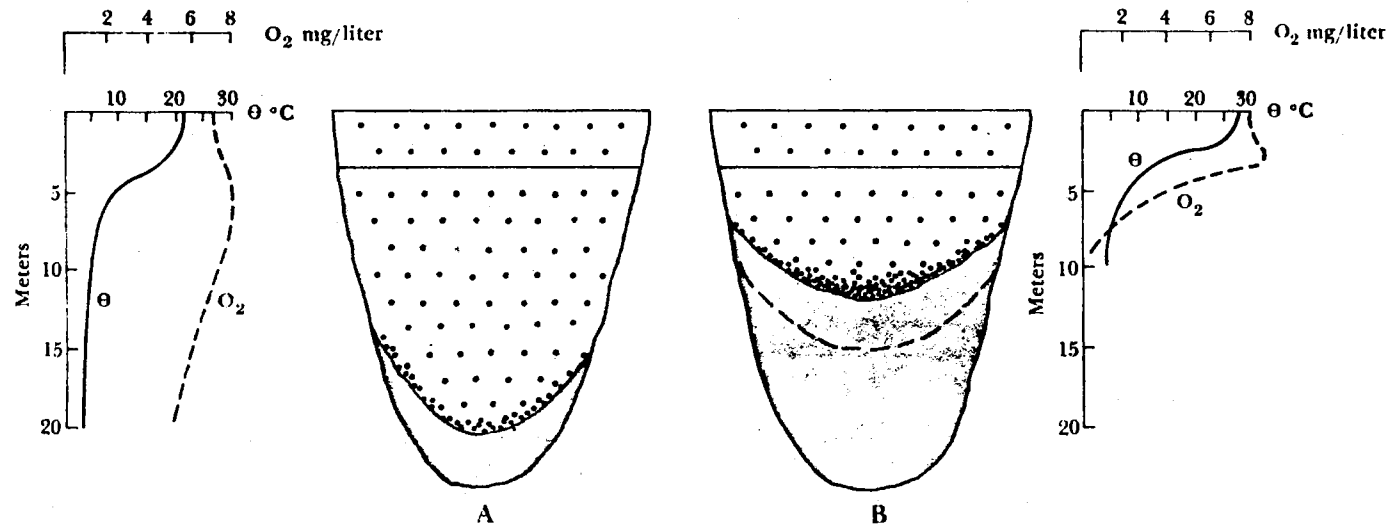

Figure 2. Diagrammatic Representation of an Oligotrophic Lake, A, and an Eutrophic Lake, B. After Hutchinson, G. E. (7)

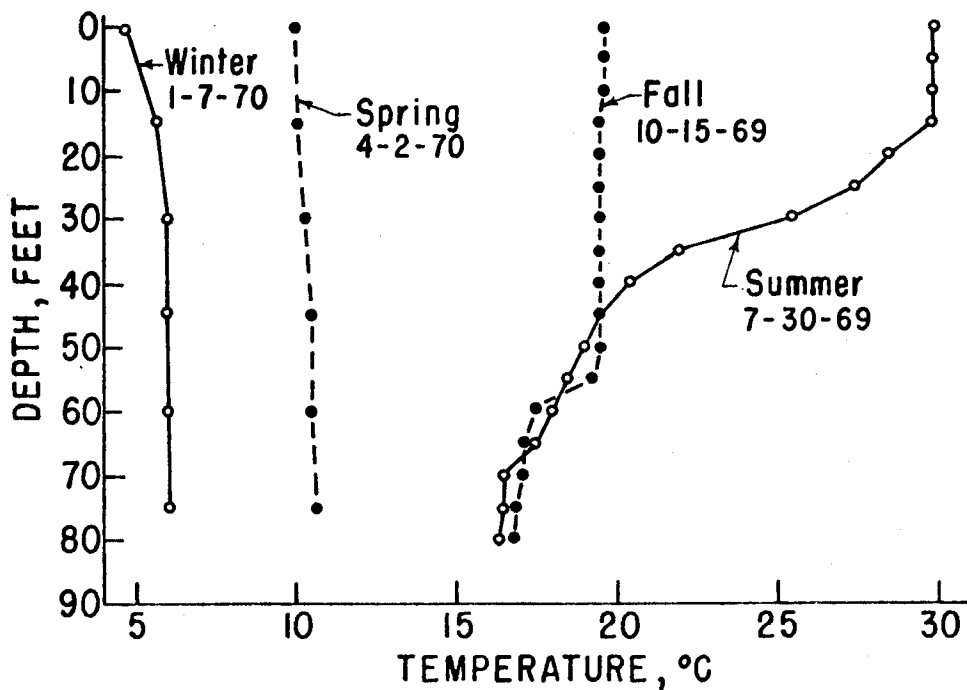
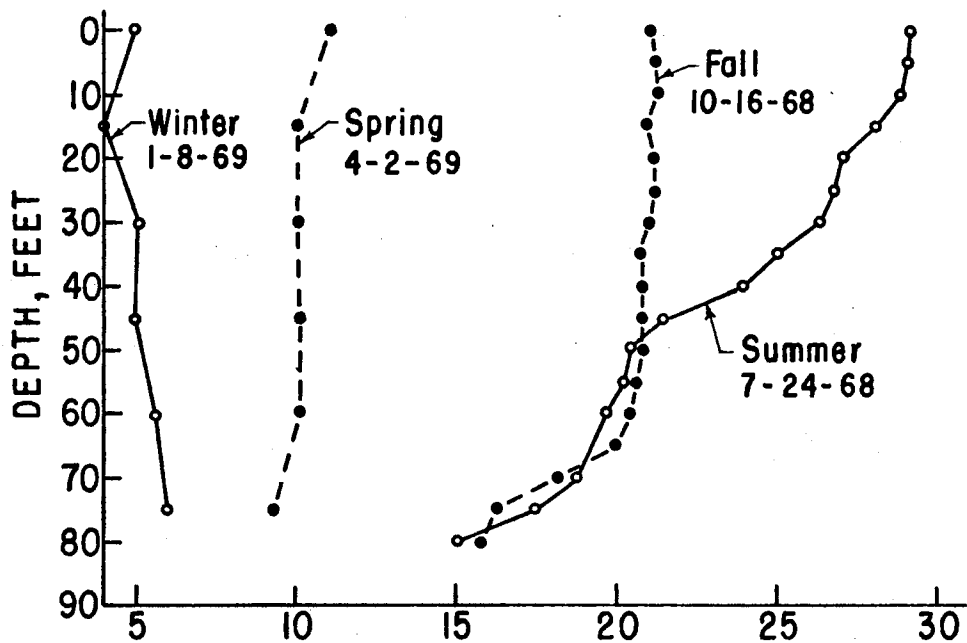

Figure 3. Temperatures for Selected Dates at One Place at Lake Arbuckle, Oklahoma. After Duffer, W. R. and C. C. Harlin, Jr. (8)

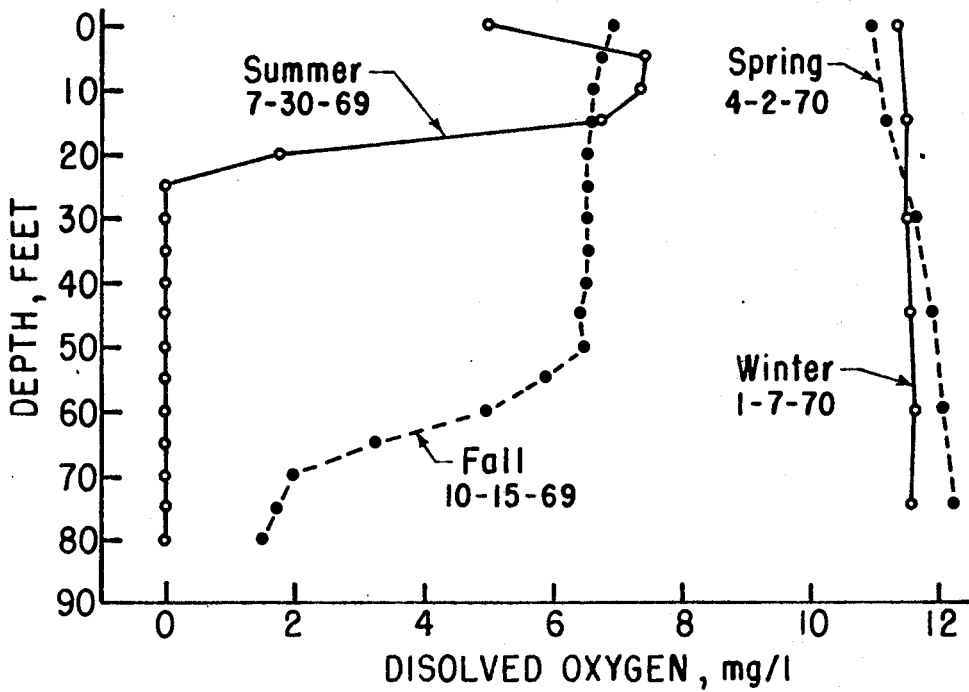
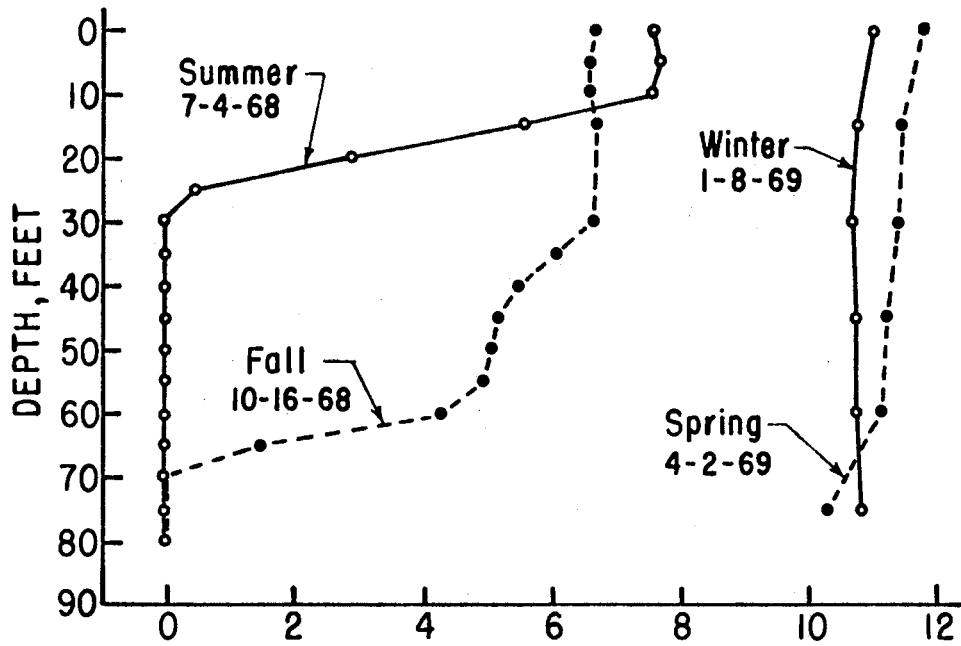

Figure 4. Dissolved Oxygen for Selected Dates at One Place at Lake Arbuckle, Oklahoma. After Duffer, W. R. and C. C. Harlin, Jr. (8)

The water quality problems involved in the use of eutrophic surface waters are a direct result of the proliferation of aquatic plants and animals. Taste and odor due to algal growths are probably the most frequent water quality problems related to eutrophication. The removal of taste and odor by physical and chemical methods is quite expensive. In a deep, thermally stratified lake, undesirable quantities of hydrogen sulfide, iron, or manganese frequently arise when anaerobic conditions occur in the hypolimnion (9).

Effects of Destratification

By definition, the primary effect of destratification is to break the layers of thermal stability allowing the entire water mass to mix. A column of water would be isothermal at all depths. At the same time other physical and chemical parameters would be brought to some mean value.

In the temperate zone most lakes are dimictic and naturally destratify and mix twice a year, once in the spring and once in the fall. The fall mixing has more similarity with artificial destratification. In the fall the hypolimnion may be anoxic and contain ammonia, hydrogen sulfide and other undesirable materials. Upon mixing, the dissolved oxygen may be dropped to zero or near zero. In combination with other toxic materials from the hypolimnion, fish kills may result naturally.

Artificial destratification generally would not cause a near instantaneous turnover such as that occurring in the fall. However, even if mixing is slower, dissolved oxygen concentrations can be lowered, because of the heavy organic load that may be present in the hypolimnion. An alternative is to continuously mix the lake beginning

in the spring before stratification occurs. This way the hypolimnion never becomes anoxic or builds up concentrations of toxic compounds.

Destratification generally results in a large increase in DO in the hypolimnion and some times a decrease in the epilimnion. This decrease in the epilimnion is thought to be due to the increased organic load brought up from the hypolimnion by mixing. Mixing may eliminate supersaturation of dissolved oxygen at the surface of lakes which contain surface scums of blue-green algae (10).

Alkalinity, pH and carbon dioxide concentrations are directly related to one another through the carbon dioxide cycle. During stratification in a eutrophic lake the high photosynthetic rate at the surface may deplete the free CO_2 causing an increase in pH. In the hypolimnion respiration produces free CO_2 , lowers pH and increases alkalinity.

The immediate effect of destratification is a decrease in surface pH and an increase in pH near the bottom (10, 11). Other changes near the bottom would include a reduction in both alkalinity and free CO_2 . Near the surface free CO_2 would be increased.

The Quality Control in Reservoirs Committee of the American Water Works Association (12) recommended artificial destratification to water suppliers who are experiencing raw water quality deterioration in their reservoirs as a result of anaerobic conditions in the hypolimnion caused by thermal stratification. The general improvement in water quality reduced treatment costs enough to make artificial destratification feasible.

Barnett (13) reported a definite decrease in chlorine demand during summer months after destratification. He also reported a reduction from

\$20,000 to \$3,000 per year spent on controlling algae blooms. This reservoir formed by Casitas Dam is located in Southern California. The coolest winter temperature throughout the lake was about 12.8° C. After three years of operation the average winter temperature had been raised about 1.1° C. If unchecked this warming could become a problem. In regions where the lakes are cooled each winter to about 4° C. or colder, there would be little problem of continuously raising the lake's temperature.

King (14) has suggested that the blue-green algae are more efficient at obtaining CO_2 from low concentrations than green algae, and that under circumstances when pH is high, as in eutrophic lakes, blue-green algae should predominate. Some species of blue-green algae have been identified as the source of taste and odor problems. Shapiro (15) investigated this hypothesis and found that by lowering pH and adding nutrients to bags of lake water dominated by blue-green algae, there was a shift to dominance of green algae. The addition of nutrients and CO_2 resulted also in a shift to green algae.

The mixing of a stratified lake is closely analogous chemically to adding CO_2 and nutrients. Symons, et al. (6) reported that when lake water dominated by blue-green algae is mixed, the blue-green algae decline and the green algae seem to become the dominant forms.

Methods of Artificial Destratification

There are two basic systems that have been used to thermally destratify a body of water. They are mechanical pumping and the release of compressed air or oxygen near the bottom of the lake.

Compressed Air

The most simple use of compressed air is to release it from diffusers along a pipe lying near the bottom of the lake. Oxygen can then diffuse into the bottom water, but more importantly it sets the entire mass of the lake in motion and can completely mix the lake. Major disadvantages are the high power requirement of air compressors, high friction losses in the air lines and the inherent low efficiency of air lift pumps.

Lake Roberts in New Mexico was destratified using an air distribution system with porcelain microporous diffusers. The compressed air supply was a 48.5 KW diesel powered air compressor. The lake had a surface area of about 28.3 hectares and a capacity of about 120 hectare-meters. Near the dam, the lake was 9 meters deep. Before mixing the stability index was 2.02 KWH and after mixing 23 hours the index was 0.47 KWH. For this period the destratification efficiency was 0.14 percent. After six days the stability index was reduced to 0.14 KWH and the destratification efficiency reduced to 0.03 percent (11).

The Aero-Hydraulics Gun is a device using air. This is a low head, high volume pump. Periodically air bubbles rise in a vertical tube to promote piston action. The rising bubble forces water above it upward and out of the pipe and entrains a volume of water behind it in the vertical tube. The bubble shatters when it reaches the top of the gun. The water "shot" from the top of the "gun" behaves as a narrow turbulent stream which entrains still further quantities of water along with it (16).

Speece describes an efficient aeration technique known as the

U-tube aeration system. Its name comes from the U-shaped path that the water flow follows as air bubbles are injected (17).

Bernhardt developed a hypolimnion aeration apparatus. The purpose of the system was to aerate the hypolimnion without breaking the thermal stratification of the lake. The system was used in Wahnbach Reservoir near Siegburg, West Germany. According to German DIN standards drinking water should be as cold as possible and not be warmer than 15° C. A duct 2 meters in diameter and 21.3 meters long produced a flow rate of 1.92 cubic meters per second when air was supplied with a compressor with a power requirement of 36.5 KW (18).

Mechanical Pumping

Water has usually been pumped from the bottom to the top of the lake (6, 19). The purpose is to pump cold, oxygen deficient water from the hypolimnion to the surface where it can be reaerated by the atmosphere. Water can also be pumped from the surface down to the hypolimnion. Quintero used an axial flow pump capable of pumping 0.67 cubic meters per second using 373 watts (2, 3). By this method warm, oxygen-rich waters are pumped to the hypolimnion where the waters mix.

With the exception of the Quintero pump, most of the destratification devices have high power requirements. Low operating cost is an important consideration for any machine. Therefore power requirement is an important design characteristic.

The flow pattern of the axial flow pump when flow exits the diffuser could be approximated by a free turbulent jet. A free (submerged) jet of turbulent fluid emerging from a circular nozzle at a Reynold's number greater than 2500 entrains some of the miscible stationary fluid,

and expands as shown in Figure 5. The outer limits of the jet are not well defined, but form a cone of half angle about 10 degrees (20).

Design of Rigid Diffuser

Gibson (21) investigated the resistance to flow of water through pipes having divergent boundaries. He found that a circular cross section diffuser was more efficient than either square or rectangular shapes. Figure 6 illustrates the relationship between head loss and the angle between divergent sides of circular pipes.

The equation used to calculate the loss in head due to enlargement is:

$$H_2 = K_2 \frac{(V_2 - V_3)^2}{2g} \quad (2-4)$$

where:

H_2 = Loss of head due to enlargement, m

K_2 = Loss coefficient for expansion

V_2 = Velocity before widening commences, mps

V_3 = Velocity after widening has ceased, mps

The coefficient K_2 is formed by the combination of wall friction effects and large scale turbulence. In the case of a sudden enlargement, the value of K_2 is 1.0.

The optimum design of a diffuser can be illustrated using Figure 7. This section consists of a straight taper pipe terminating in a sudden enlargement. The case of a diffuser for the destratification pump would be the same, except that the sudden expansion is into an infinite lake.

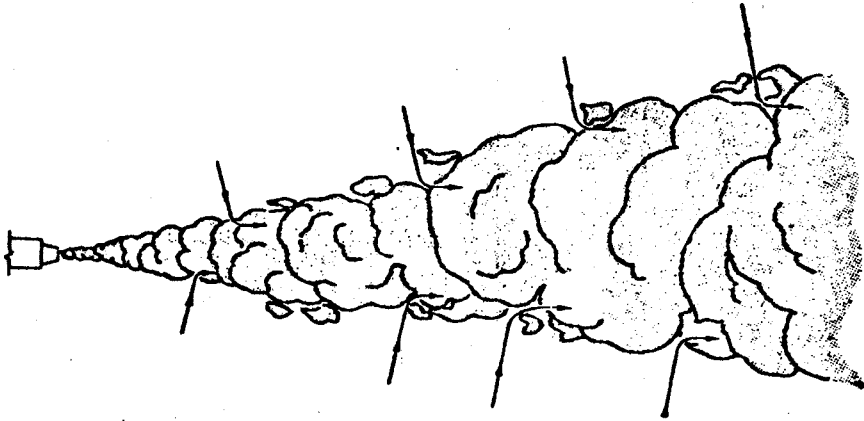

Figure 5. Free Turbulent Jet Emerging from Submerged Nozzle into Large Volume of Miscible Fluid. The Expansion of, and Entrainment by, the Jet are Shown Diagrammatically. After Davies, J. T. (20)

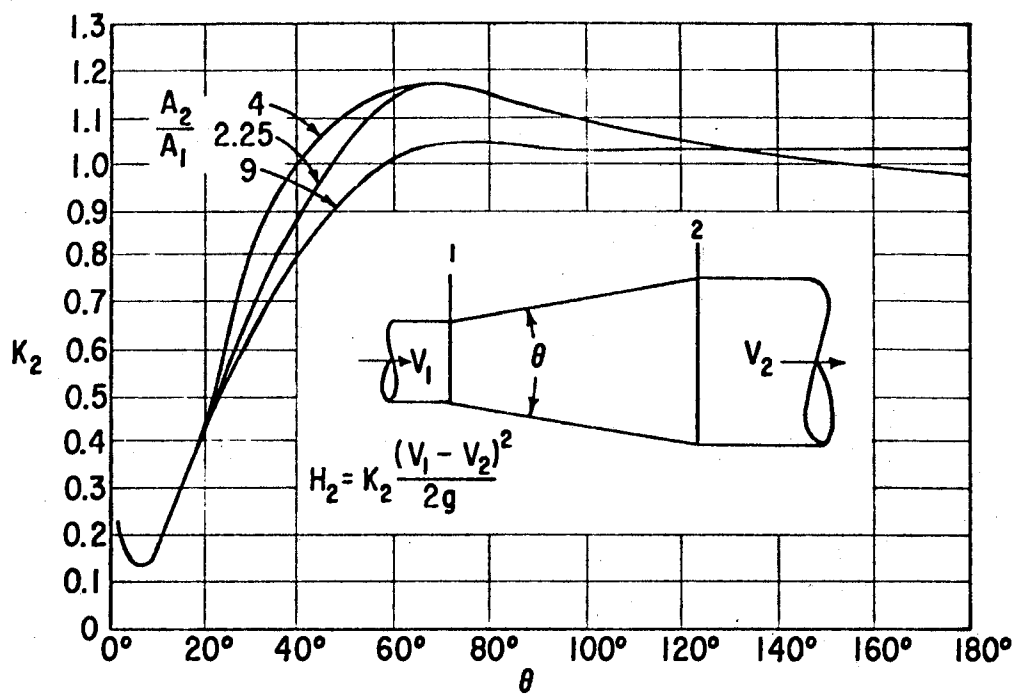

Figure 6. Loss Coefficients for Conical Enlargements (22)

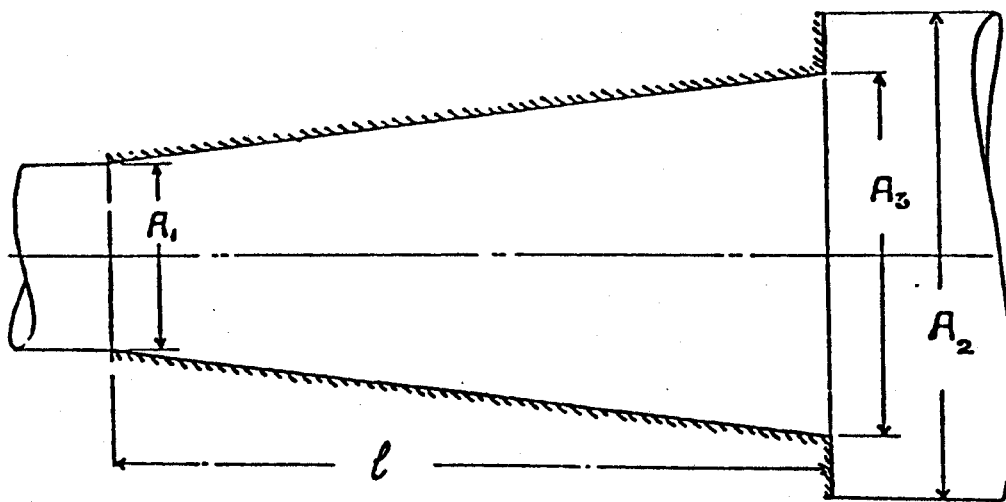

Figure 7. Diagram of Diffuser Terminating with a Sudden Enlargement. After Gibson, A. H. (21)

The loss is theoretically equal to:

$$\text{Loss} = K_2 \frac{(V_1 - V_3)^2}{2g} + \frac{(V_3 - V_2)^2}{2g} \quad (2-5)$$

Since V_2 is zero.

$$\text{Loss} = K_2 \frac{(V_1 - V_3)^2}{2g} + \frac{V_3^2}{2g} \quad (2-6)$$

The coefficient K_2 is a minimum when the angle is about 6 degrees. As the angle is increased, K_2 increases and the loss due to the first term in Equation (2-6) increases. Meanwhile the second term decreases as the angle increases. An optimum solution can be obtained by trial of several angles.

CHAPTER III

EXPERIMENTAL EQUIPMENT

Pump

The axial flow type pump built by Quintero was modified and used in this project. The three major parts of the pump are: a propeller, a stationary casing and a diffuser (Figures 8 and 9). The modifications included changing the propeller and designing a rigid diffuser.

The nine-bladed propeller (Figure 10) had an effective diameter of 1.06 meters. The chord angle of the blade varied from about 44° near the hub to about 20° at the tip. The hub was 0.292 meters in diameter. Quintero's propeller was the same diameter but had seven blades and the pitch varied between 10° and 20° . Both propellers had been originally designed for blowing air.

The pump body or casing (Figure 11) consisted of an air fan housing shroud with a bell mouth type entrance having a radius of curvature of 0.07 meters. A cylinder 0.737 meters long and with an inside diameter of about 1.07 meters was added. A circular rim or lip 0.305 meters wide was added to the entrance.

Beneath the pump a rigid metal diffuser was installed. The length was limited by the lake's depth and set at 4.88 meters. The inlet diameter, D_1 , was 1.07 meters. The loss in Equation (2-7) was calculated for several values of the outlet diameter D_3 . The choice of optimum

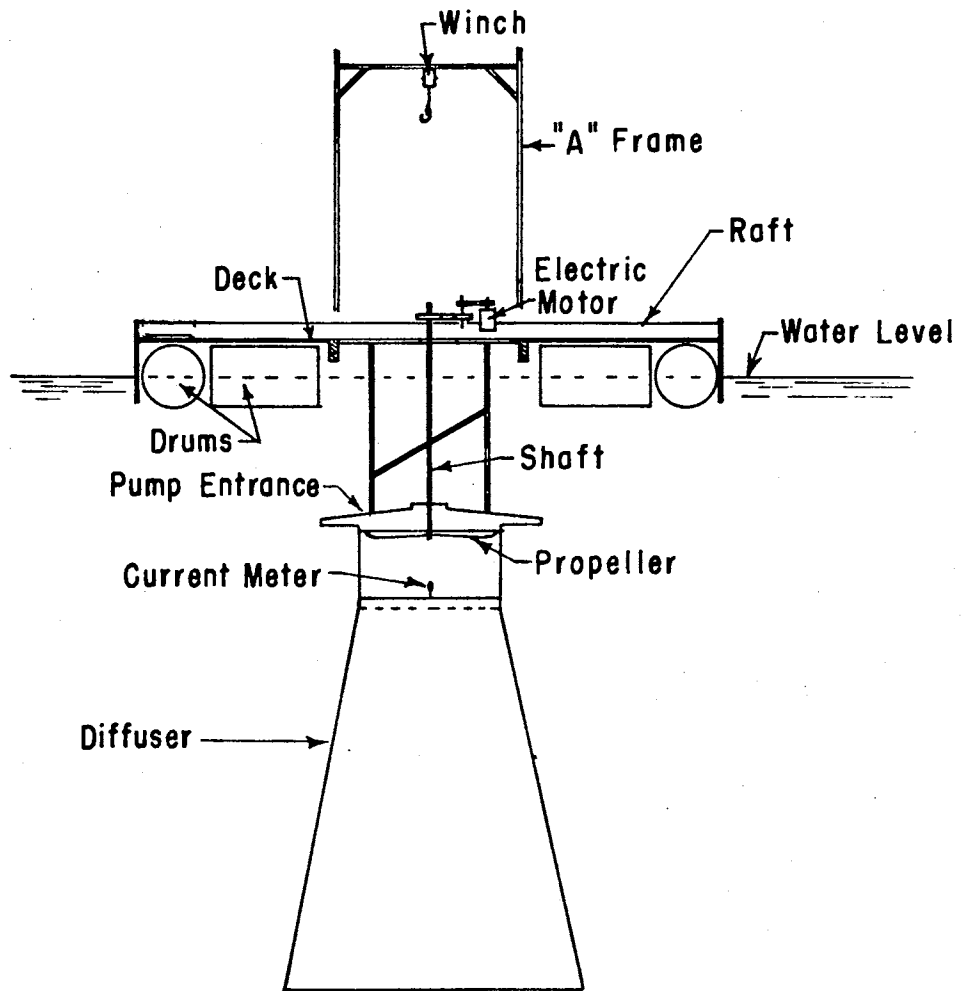

Figure 8. Assembly of Pump and Raft

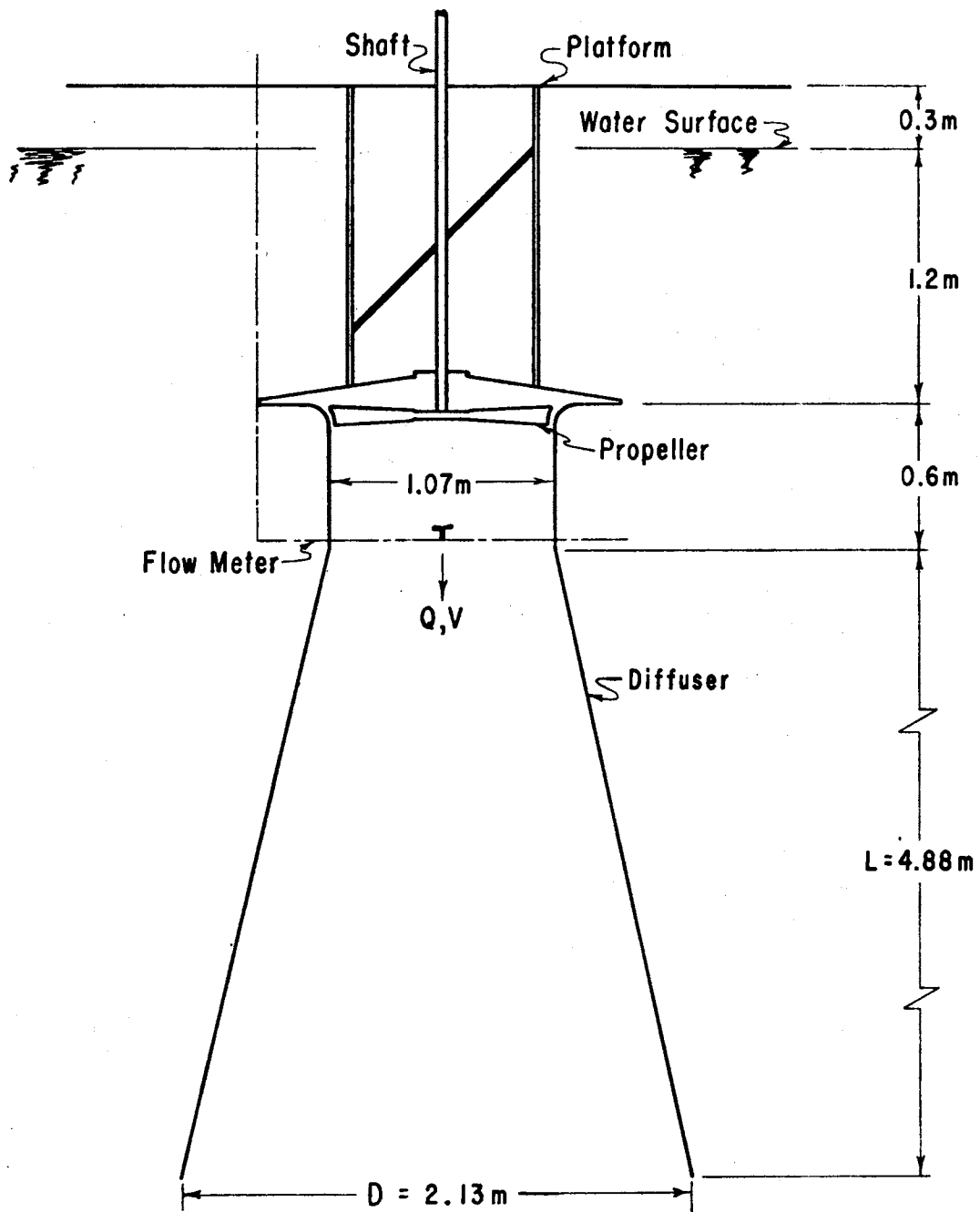

Figure 9. Pump Model

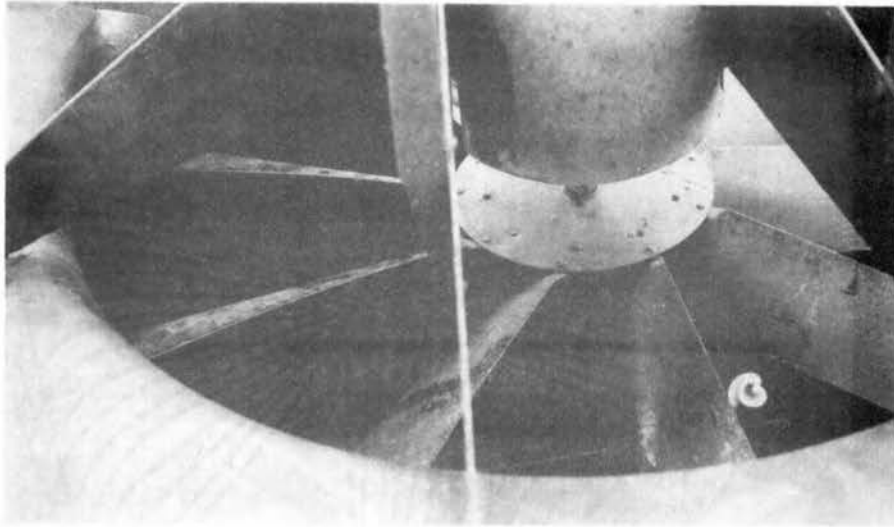

Figure 10. Propeller and Current Meter
in Pump Casing

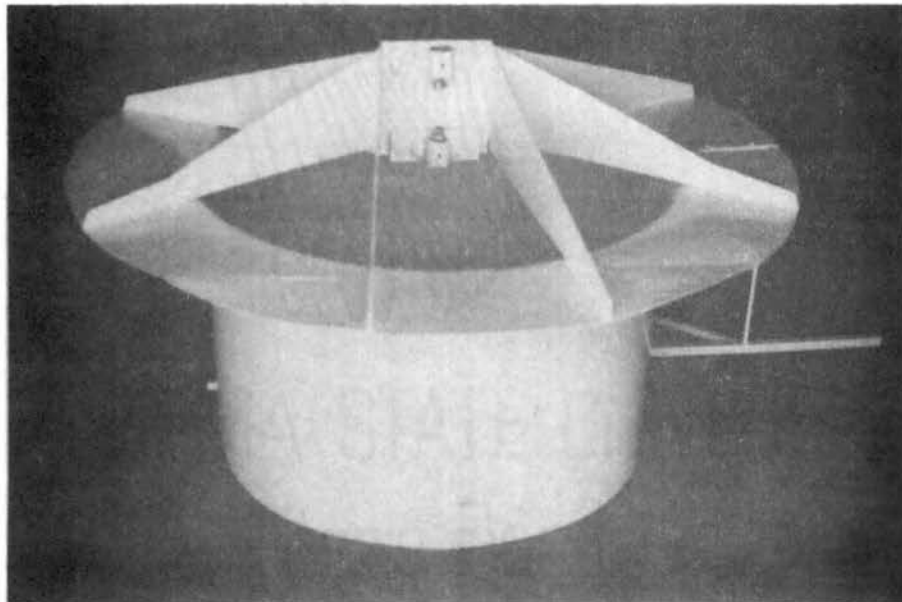

Figure 11. View of Casing

dimension is independent of the inlet velocity. Inlet velocity was assumed as 0.91 meters per second in order to calculate a head loss. Table I is a summary of these calculations.

TABLE I
DIFFUSER HEAD LOSSES

D_3 Meters	ϕ Degrees	K_2	Loss Meters
1.83	8.9	0.15	0.0155
1.98	10.7	0.18	0.0149
2.13	12.5	0.20	0.0149
2.29	14.2	0.25	0.0171
2.44	16.0	0.27	0.060

The optimum outlet dimension was between 1.98 meters and 2.13 meters. The 2.13 meter dimension was selected because it was twice the inlet diameter and had four times the inlet area. Gibson (21) conducted some of his tests, used to determine Figure 6, with diffusers of the same area ratio. The resulting optimum diffuser had the following dimensions:

Inlet diameter	1.07 meters
Outlet diameter	2.13 meters
Length	4.88 meters

The diffuser was constructed using a frame of structural steel angles bent into hoops and connected with square steel tubing (Figure 12). The interior was covered with sheet metal (Figure 13). Floats were attached to the diffuser to balance its weight while in the water, and to ease installation.

Supporting Structure

The pump was supported by a frame 1.83 meters long (Figure 14). This dimension allowed the propeller blade to operate 1.22 meters below the surface. A pair of gimbal joints (Figure 15) connected the frame to the floating platform. The joints allowed the pumping unit to remain relatively motionless while the platform rocked in the water. Attached to the top of the frame was the electric motor, pulleys, shaft and shaft bearing.

Platform

A wooden raft (Figure 16), 2.44 meters by 4.88 meters, held and located the pump in the lake. The raft floated on 10 barrels and had a flotation capacity of about 1130 kilograms. Part of the floor could be removed to allow raising the pump. A 2.44 meter A-frame with a winch was used to lift the pump.

Power Supply

A 120v/240v electrical power supply was brought from shore by an underwater cable. A 373 watt Dayton electric motor was mounted on the frame. For the power and flow rate tests positive drive (timing belts) was used to avoid slippage. Several different pulleys were used to vary



Figure 12. Exterior View of
Diffuser

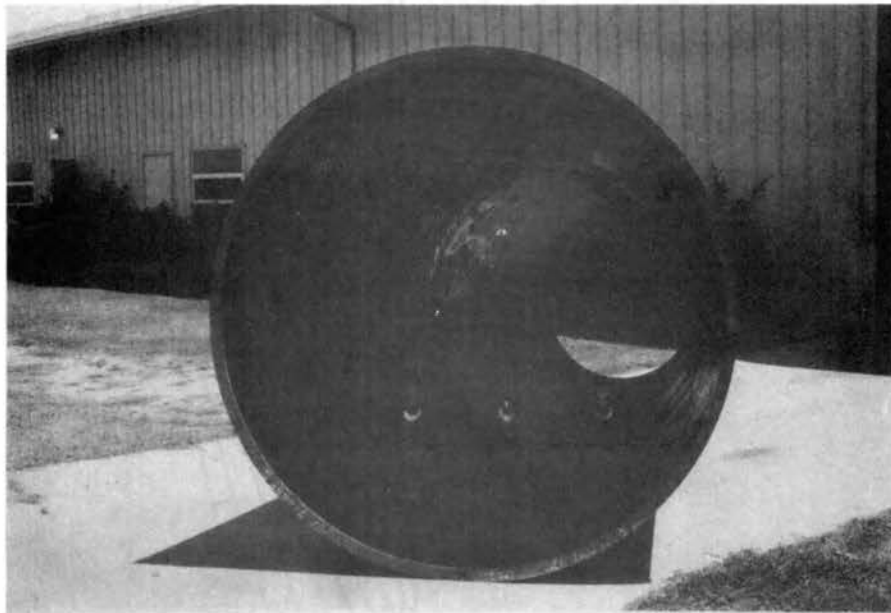

Figure 13. Interior View of Diffuser

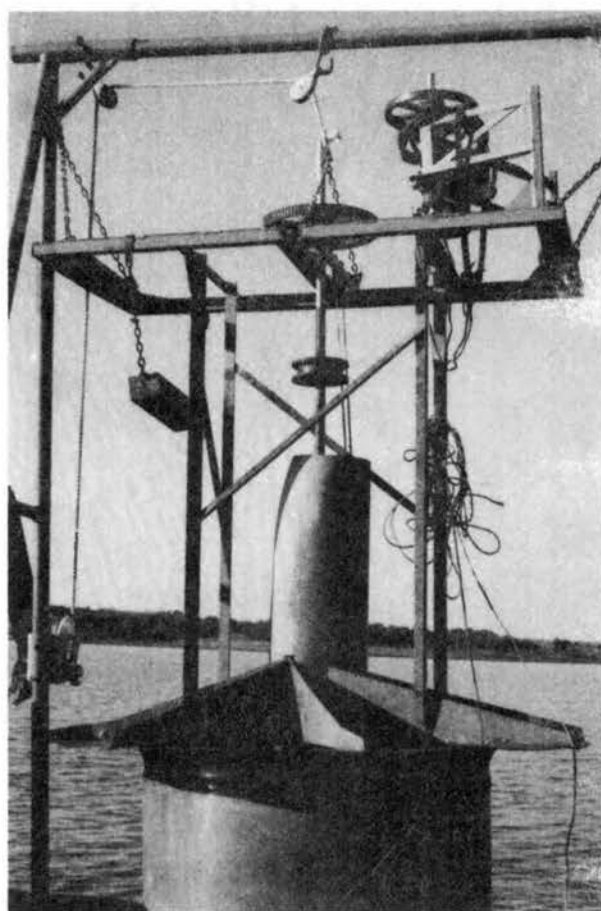

Figure 14. Supporting Structure

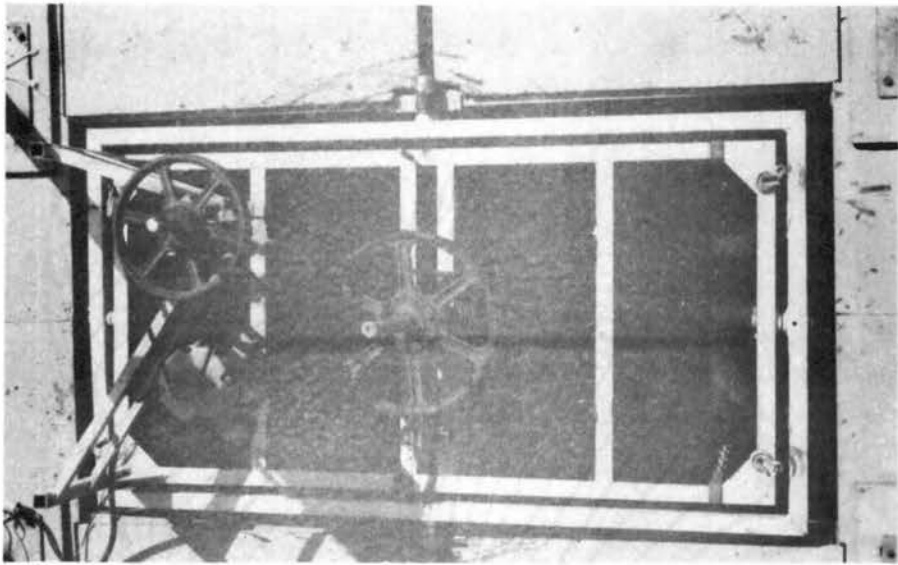

Figure 15. Supporting Frame with Gimbals

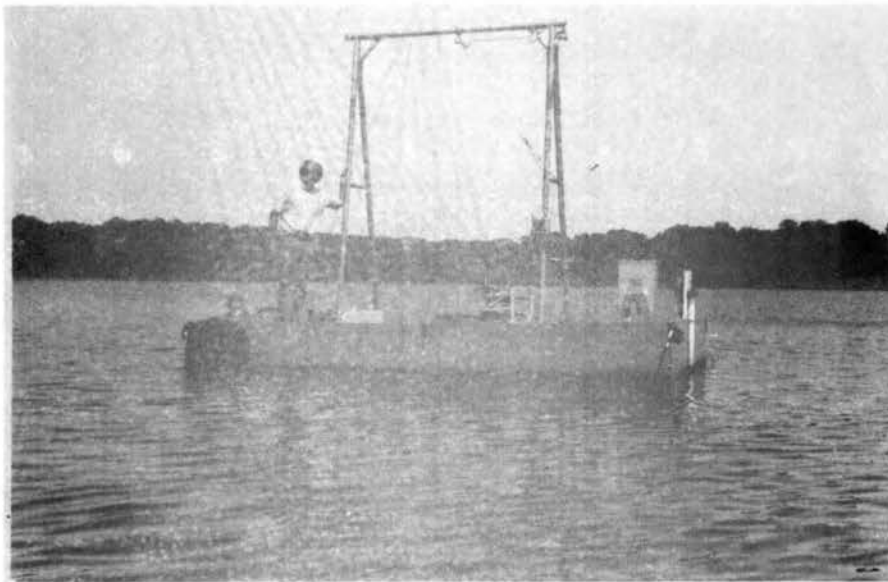

Figure 16. General View of Raft,

the speed of the propeller shaft between 33 rpm and 56 rpm. The calibration was made using a prony brake in the lab. This calibration curve is Figure 17. During ordinary operation of the pump a V-belt drive system was used.

Measuring Devices

The velocity of water flowing through the pump's throat was measured using a laboratory "Ott" current meter (Figure 10). A factory calibrated propeller 50 mm in diameter with a 0.05 pitch was selected. The propeller was capable of measuring velocities in the range of 0.05 to 3.0 meters per second. The propeller calibration equation was used to calculate the water velocity based on the revolutions per second of the propeller. The instrument measuring the revolutions per second is shown in Figure 18. The average throat velocity was measured using a system proposed by Henderson (23). This system involved dividing the conduit into six equal concentric areas (Figure 19). A velocity reading was made at the center of each area and an average of the six areas was taken as the average throat velocity.

Power input to the electric motor was measured using a small scale wattmeter. The prony brake calibration curve was then used to measure the propeller shaft horsepower. Voltage and amperage were also measured. The instruments were assembled as shown in Figure 20.

Temperature and dissolved oxygen profiles were measured using a Tex-A-Dyne Mark IV oxygen monitor (Figure 21). This electronic device was checked frequently using the Azide modification of the Winkler method of determining dissolved oxygen as explained in Standard Methods, (24).

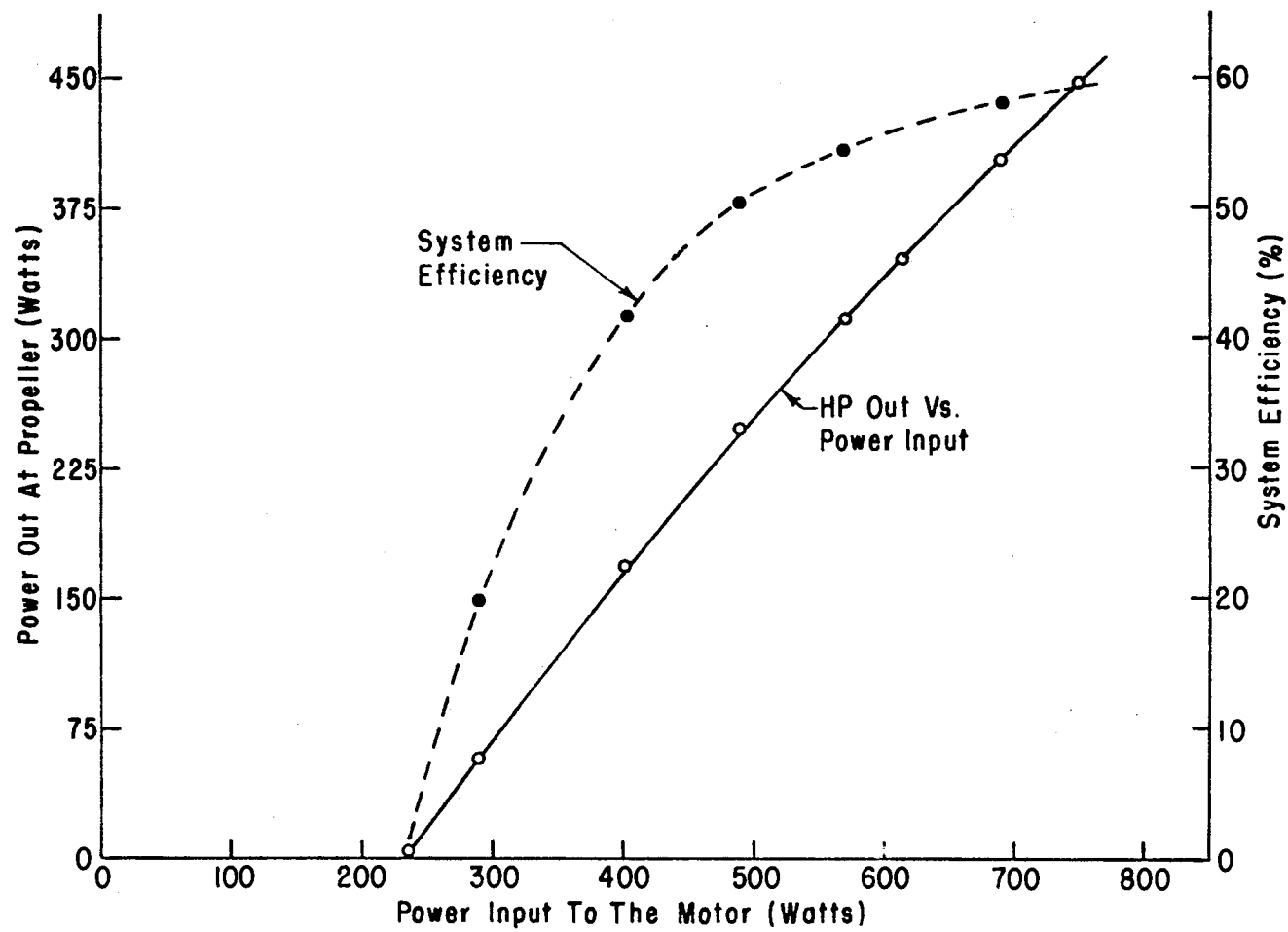

Figure 17. Results of Prony Brake Tests (3)

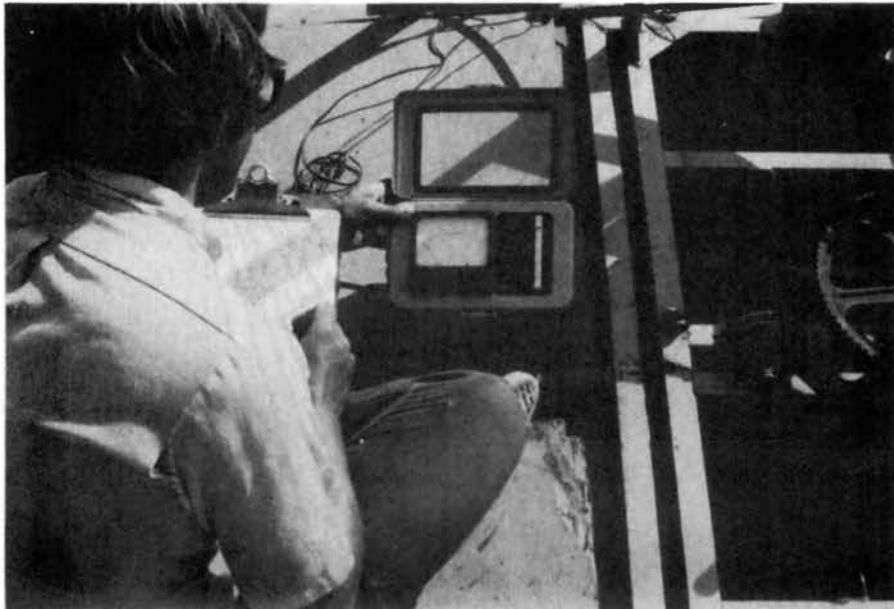

Figure 18. Measurement of Velocity

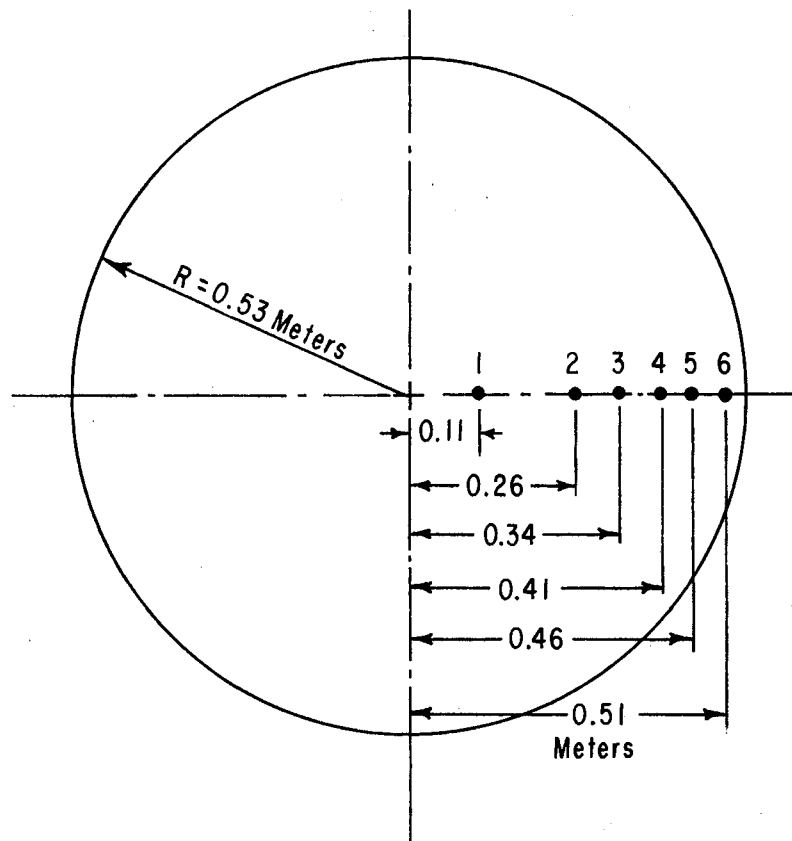

Figure 19. Points Where Velocity was Measured in Pump Section

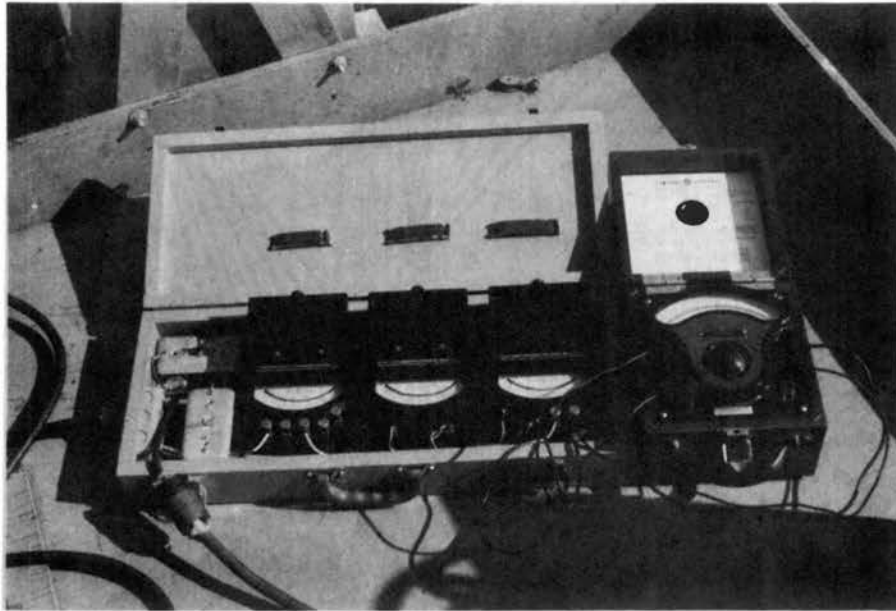

Figure 20. Power Measuring Instruments

Water samples at various depths were taken with a Van Dorn water sampler (Figure 22). The pH was measured in the laboratory using a Coleman model 37A portable pH meter.

Conductivity measurements were made using a Yellow Springs Instrument Co. model 31 conductivity bridge.

Location of Equipment

Ham's Lake is a Soil Conservation Service flood detention reservoir located about five miles west of Stillwater, Oklahoma. The lake has a surface area of almost 40 hectares and a volume of 115 hectare-meters when at principal spillway elevation of 287.0 meters above sea level. Area and capacity curves are shown in Figure 23. The deepest location is about 9.5 meters. A map of the lake profile is shown in Figure 24. Although it is a relatively shallow lake, it does exhibit thermal stratification. The temperature difference between the surface and the bottom is similar to deeper lakes in Oklahoma, for example Lake Arbuckle. In addition, oxygen stratification is very pronounced. During summer the surface water is supersaturated while the dissolved oxygen goes to zero between three and four meters depth.

A caged catfish farming operation used Ham's Lake for several years. During this time a heavy organic load was built up from uneaten feed and catfish waste. An example of the catastrophic events possible when a stratified lake suddenly mixes occurred in late August of 1972. An extended cool, cloudy spell had lowered the temperature of the surface water. Even though two surface aerators were operating among the cages, the dissolved oxygen was reduced to between 2 mg/l and 3 mg/l. During one night the lake became unstable and the entire water mass mixed.



Figure 21. Measuring DO and Temperature Profiles with Electronic Monitor



Figure 22. Van Dorn Water Sampler

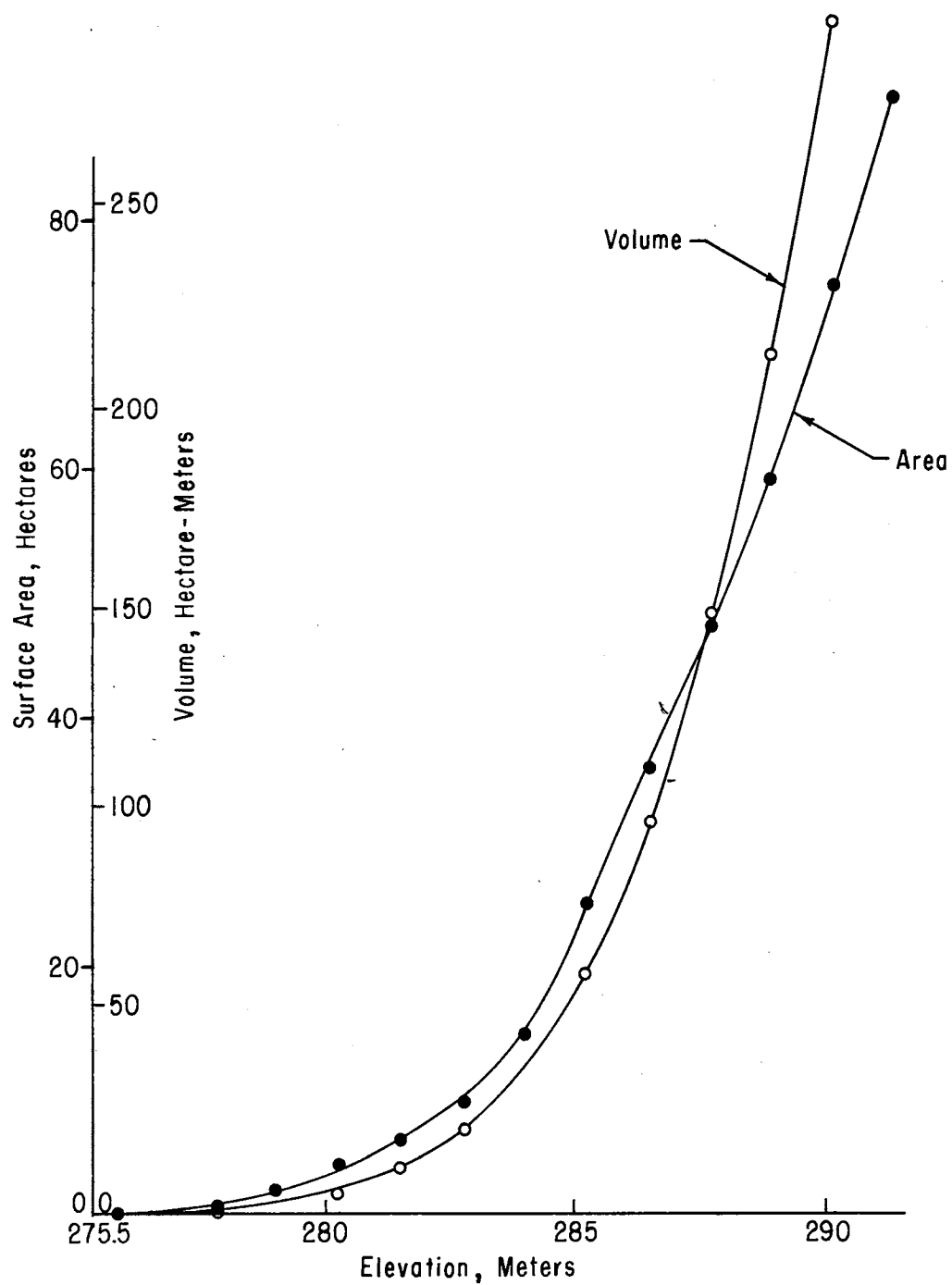

Figure 23. Area and Volume Curves for Ham's Lake

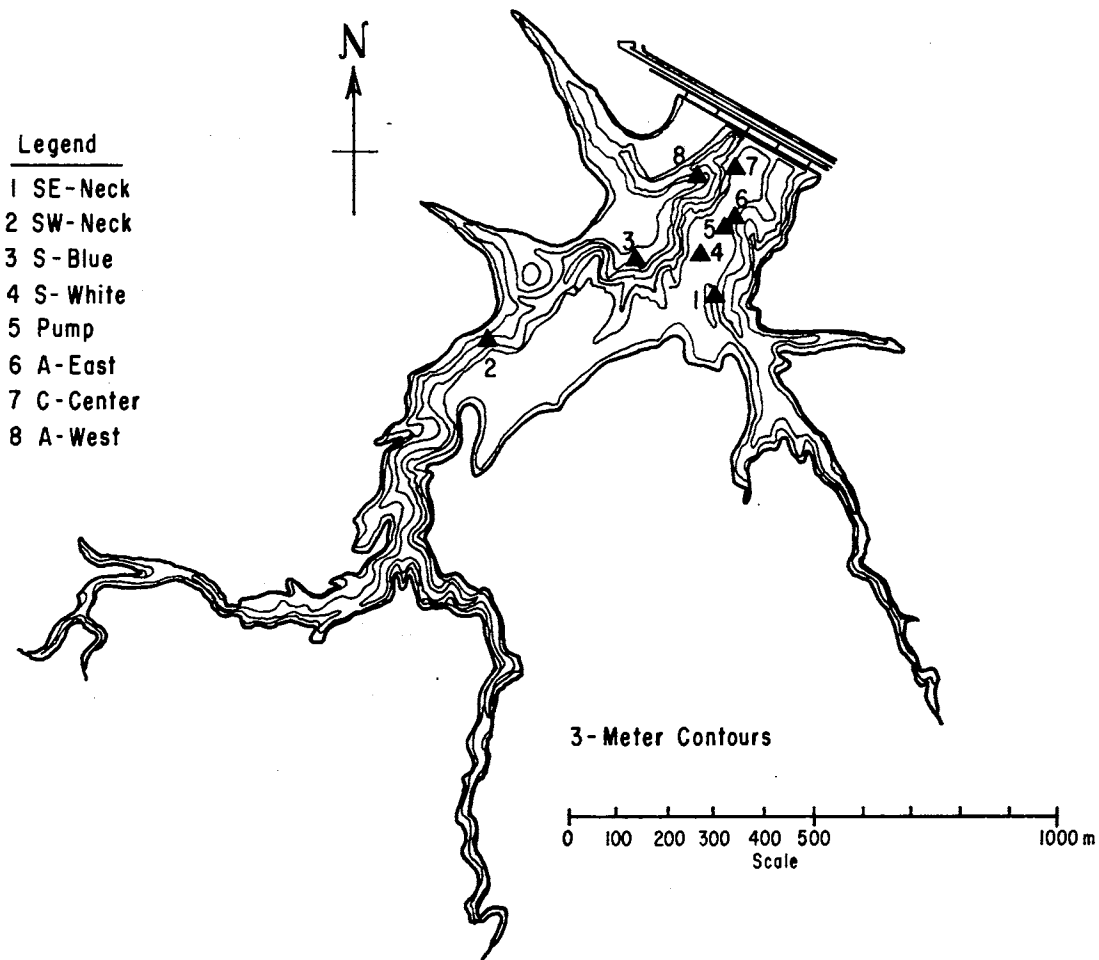

Figure 24. Map of Ham's Lake Showing Sampling Locations

The dissolved oxygen dropped to very near zero while ammonia and hydrogen sulfide were mixed throughout the water column. This combination of events was lethal to about 200,000 nearly market size caged catfish, even those directly next to the aerators. As best could be determined no free swimming catfish died. Apparently most swam up into the necks and found areas where they could live. The cause of the fish kill could partly be explained by the dense packing of fish in the cage culture operation, though fish kills due to lake turnover have been reported (11).

CHAPTER IV

METHODS AND PROCEDURE

A major objective of this study was to determine the effect of the pump's operation on a stratified lake. Therefore, the lake was first allowed to stratify. The pump was then operated for one week without the diffuser attached, to determine if it was necessary in order for the pump to destratify the lake. The pump was then operated the rest of the season with the diffuser attached.

Eight stations were located by floating markers on the lake. Each day readings of dissolved oxygen (DO) and temperature were made at one meter increments at each station. These readings were always made in the morning beginning at 9:00 a.m. The electronic probe was used for these readings and checked regularly using a standard thermometer and the Winkler method for DO. Each day a surface sample was taken from near the platform to determine turbidity. This reading was made using a spectrophotometer and a calibration to Jackson turbidity units.

Water samples were taken using the Van Dorn water sampler. The samples were taken from the platform until June 20; after that date a station about 30 meters north of the platform was used. All water samples were taken from 1, 3, 5, 7 and 9 meters below the surface. Twice each week measurements of pH and conductivity were made using laboratory instruments. Using the same samples, total alkalinity and carbonate alkalinity were determined using the procedure from

Standard Methods (24). Carbon dioxide concentrations were determined by nomograph (Figure 25) using the pH and alkalinity measurements. The nomograph was constructed using data from Moore (25). Once each week samples for determining the 5-day biochemical oxygen demand (BOD_5) were taken. The procedure from Standard Methods was followed.

Composite algae samples were taken twice each week and preserved using Lugol's solution. The composite sample was made by taking 125 ml samples from the surface and 1 and 2 meter depths at several stations, and mixing them together. The identification and counting of the algae was done by an aquatic biologist.

The mechanical evaluation of the pump consisted of measuring the shaft power, pump flow rate and propeller rpm both with and without the diffuser. The propeller rpm was varied by changing pulleys on the motor shaft. Observations of average throat velocity, propeller rpm and watts were made for each condition.

Revolutions per second of the flow meter were recorded to the nearest 0.1 rpm. One value was recorded for each position of the flow meter. The velocity in m/sec. was calculated for each reading using the manufacturer's calibration curve. The average throat velocity was taken as the average of the six readings for each of the six equal areas.

The power input to the motor was measured to the nearest 1.0 watt. Using the calibrations curve from the prony brake test (Figure 17), values for power output of the shaft were determined.

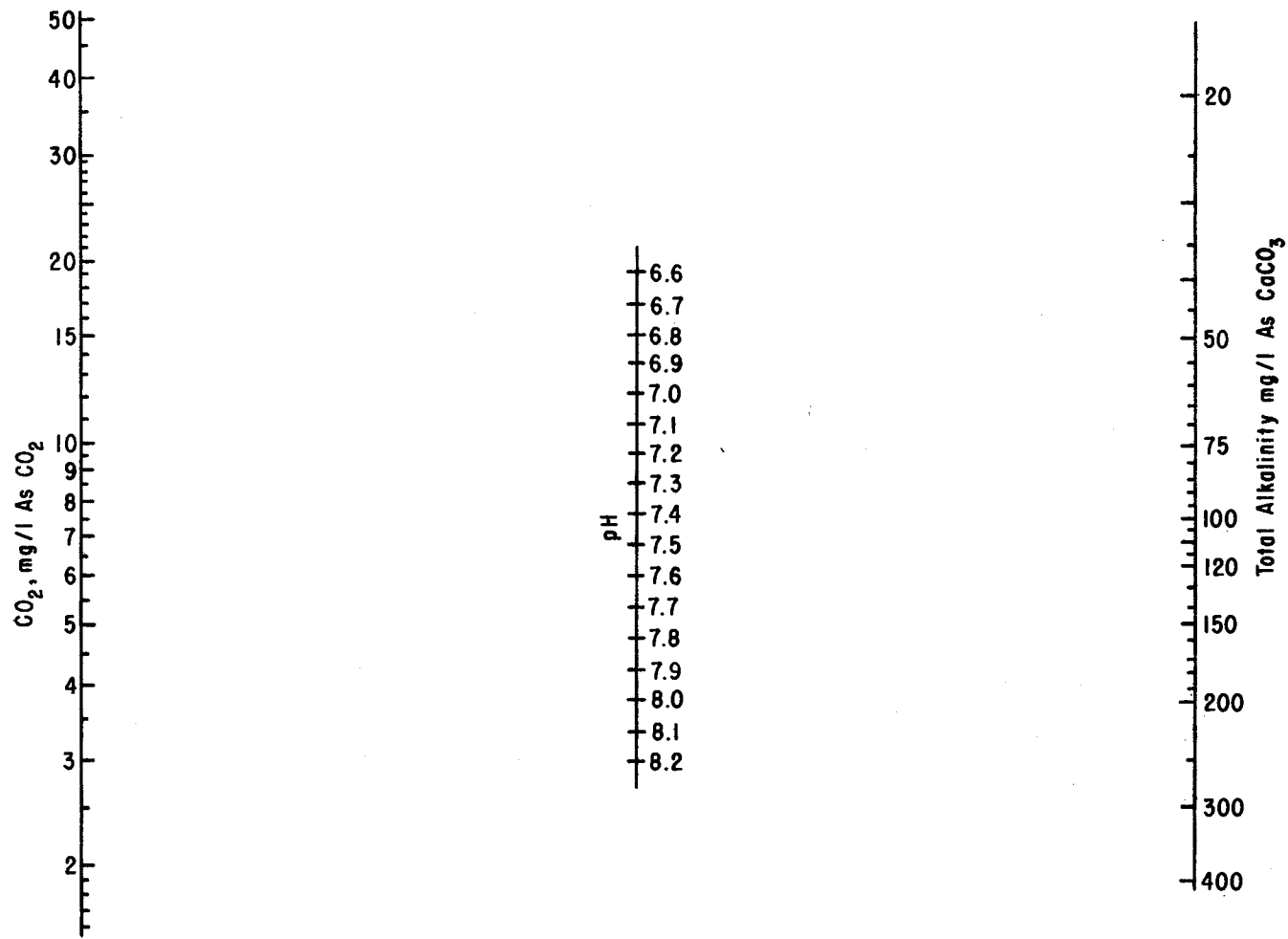

Figure 25. Nomograph for Calculating CO_2 from pH and Alkalinity

CHAPTER V

PRESENTATION AND ANALYSIS OF DATA

The data gathered in this research project falls into three categories: physical-chemical, biological and mechanical analysis of the pump and diffuser.

Physical-Chemical

Observation of physical-chemical parameters was used to determine the effectiveness of the pump's destratification capability. Changes in these parameters are easier to measure and analyze than the biological parameters.

Temperature and Dissolved Oxygen

The temperature and DO are probably the most important parameters that affect a lake. During periods of stratification aerobic biota are excluded from the hypolimnion by anoxia.

Figure 26 illustrates the changes in the temperature profile at one station located about 30 meters from the pump. Other locations showed similar profiles. On July 14 before any pumping was begun, the surface water temperature was warmer than on June 29; however in deeper layers the temperatures were nearly the same. On both dates strong temperature stratification was observed. On July 14 there was a 13.5^o C. temperature difference between the surface and the bottom. In the afternoon

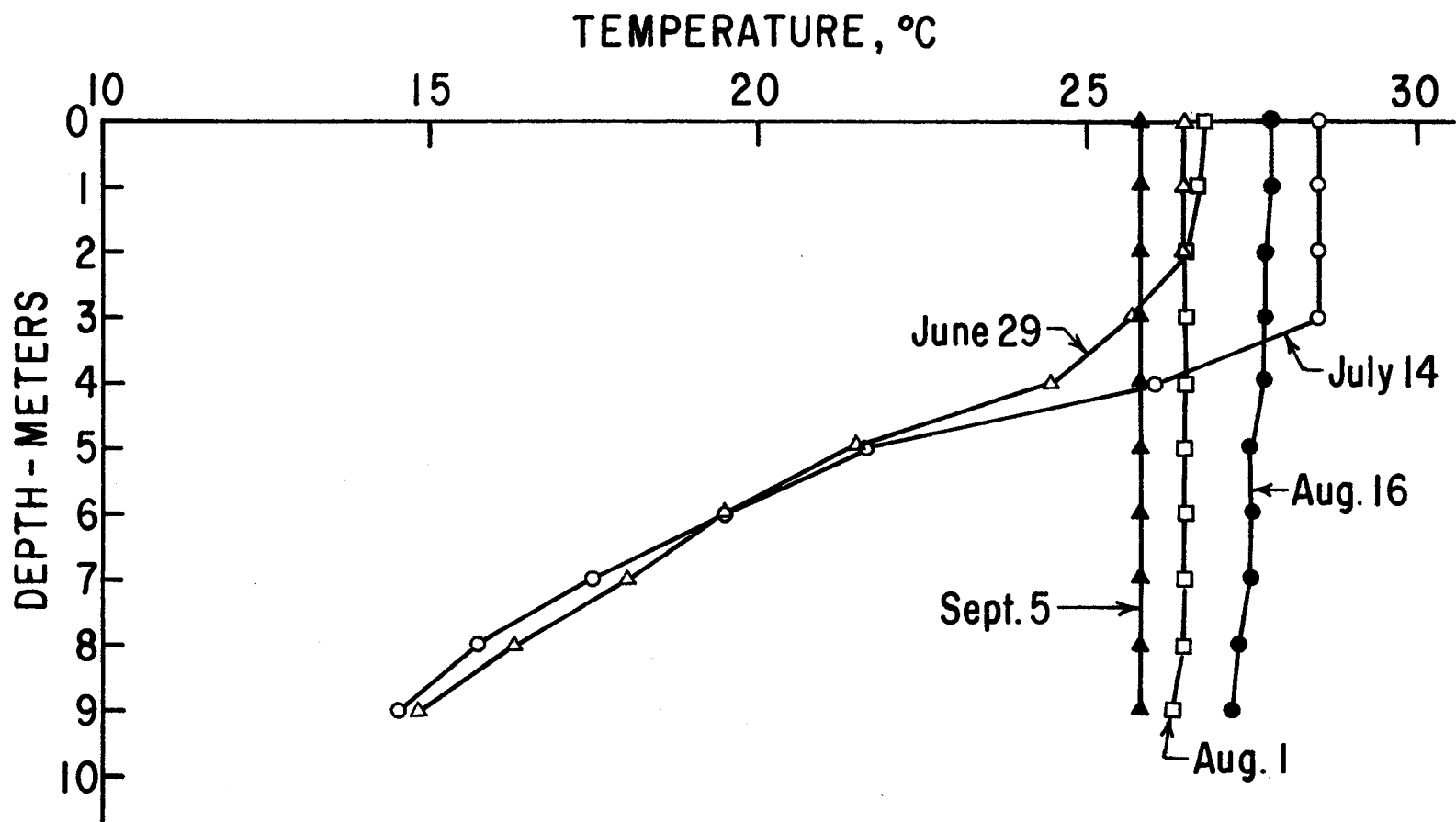

Figure 26. Typical Temperature Profiles

the temperature difference would be even greater since the surface often warmed to near 30° C.

The pump was operated 9 1/2 hours on July 14 and operated continuously after 9:00 p.m. on July 16. From July 16 to July 23 the pump operated without the diffuser. The diffuser was installed during the afternoon of July 23. The pump was then operated continuously until the last week of October.

Operation of the pump without the diffuser for 9 1/2 hours on July 14 warmed the hypolimnion water about 1.5° C. Also DO was present at 4 and 5 meters depths away from the platform. At the platform DO was present at 6 meters. Before pumping, DO was absent at 4 meters everywhere in the lake. Since the pump had an effect on the hypolimnion even though a diffuser was not used, the pump was operated for 7 days without the diffuser. The lake warmed uniformly regardless of location. In other words, the temperature at a particular depth would be the same whether it was near or far away from the pump platform. Figure 27 illustrates this fact with seven meter temperature readings taken at several locations. Other depths show similar results.

On August 1 the temperature profile was nearly constant at 26.5° C. After August 1 the temperature difference in the water column was less than 1° C. By August 16 the general temperature of the lake had increased about 1° C. but the temperature profile was still nearly uniform. Fall cooling is evident by the decreased but still uniform temperature on September 5.

The warming of the lake from the start of pumping can be seen in Figures 28, 29, and 30. First observation shows that the coldest water at 9 meters warmed at the fastest rate. For about the first three days

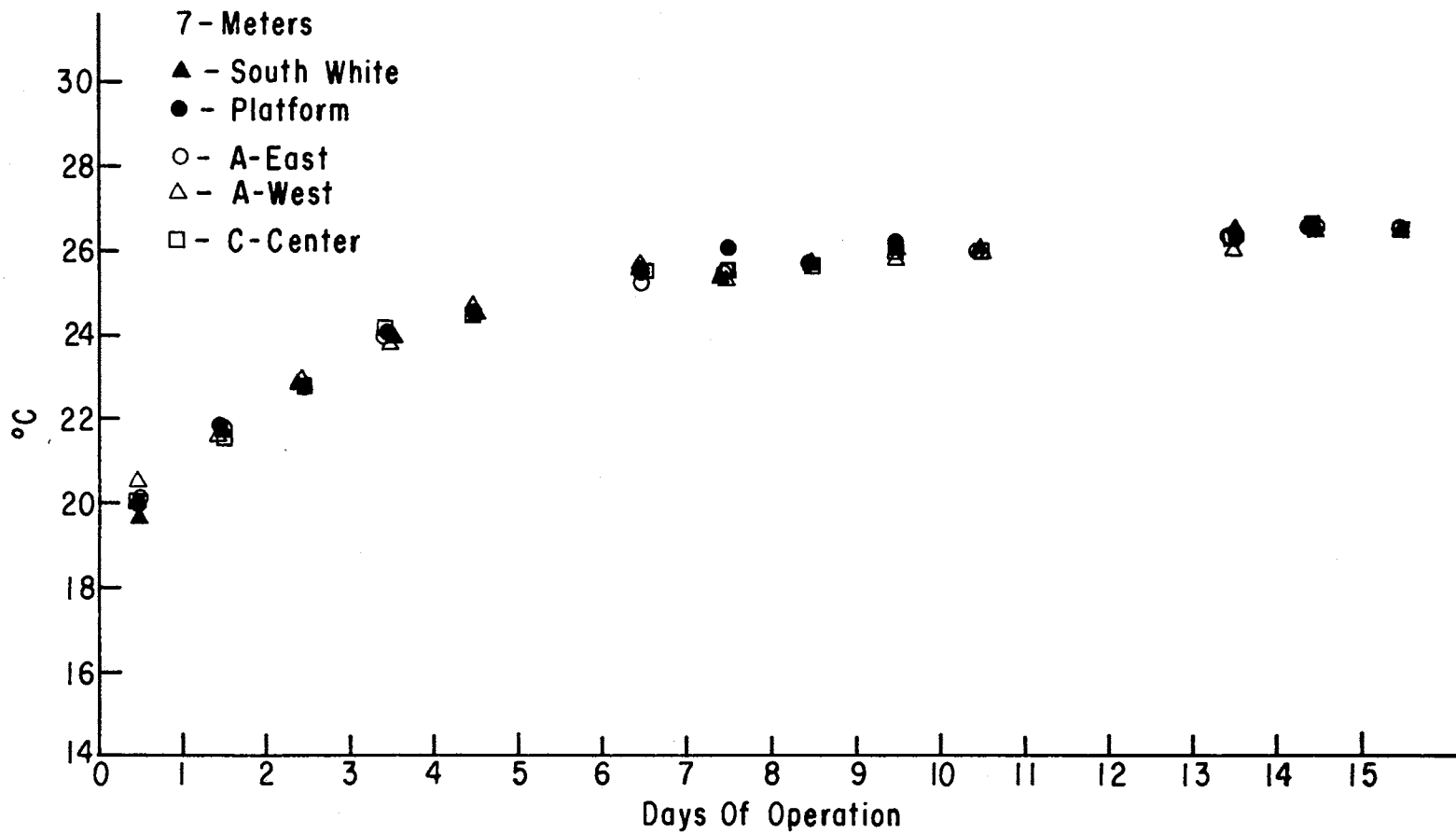

Figure 27. Plot of Temperature Versus Time for Readings Taken at the Seven Meter Depth at Various Locations

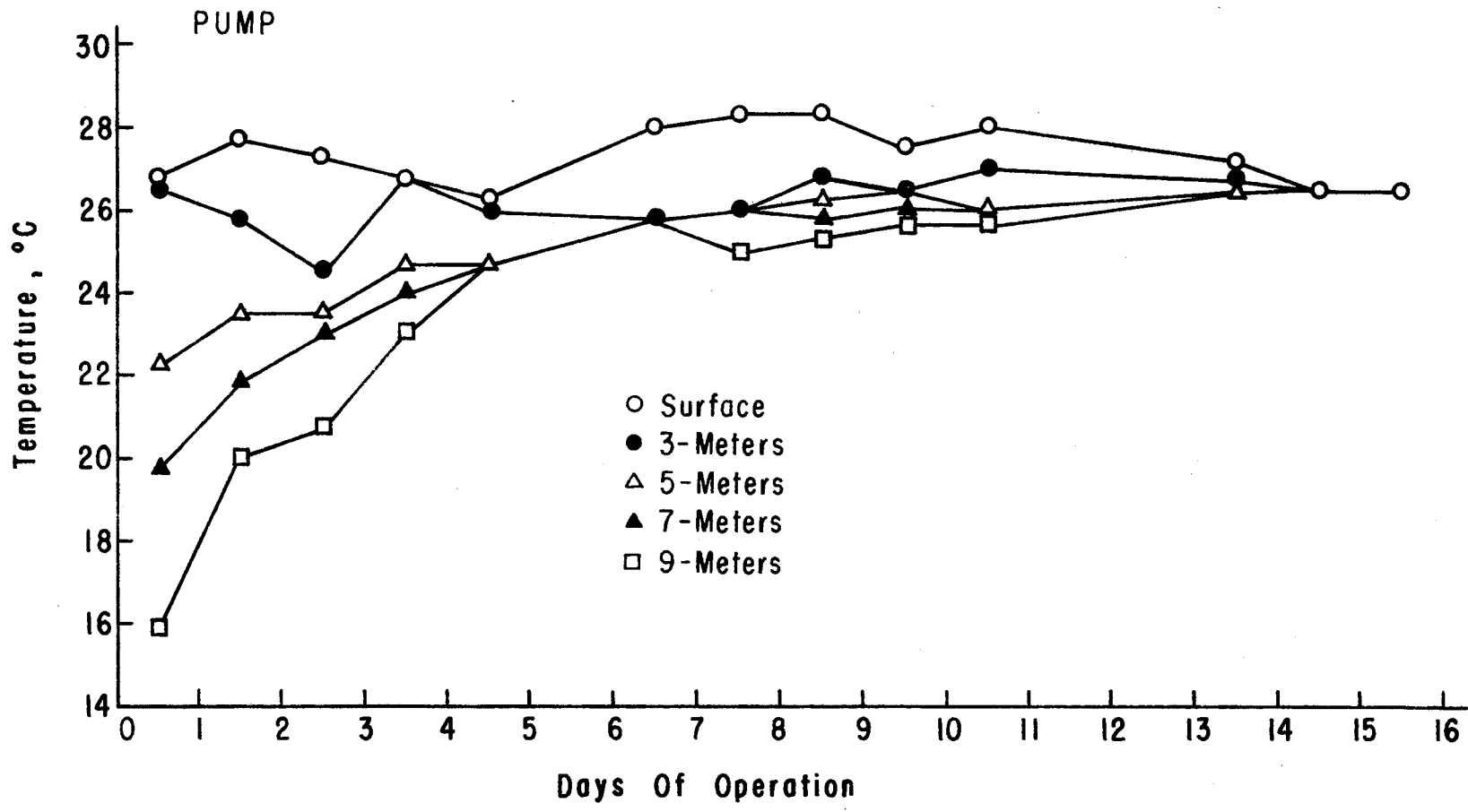

Figure 28. Plot of Temperature Versus Time at Pump

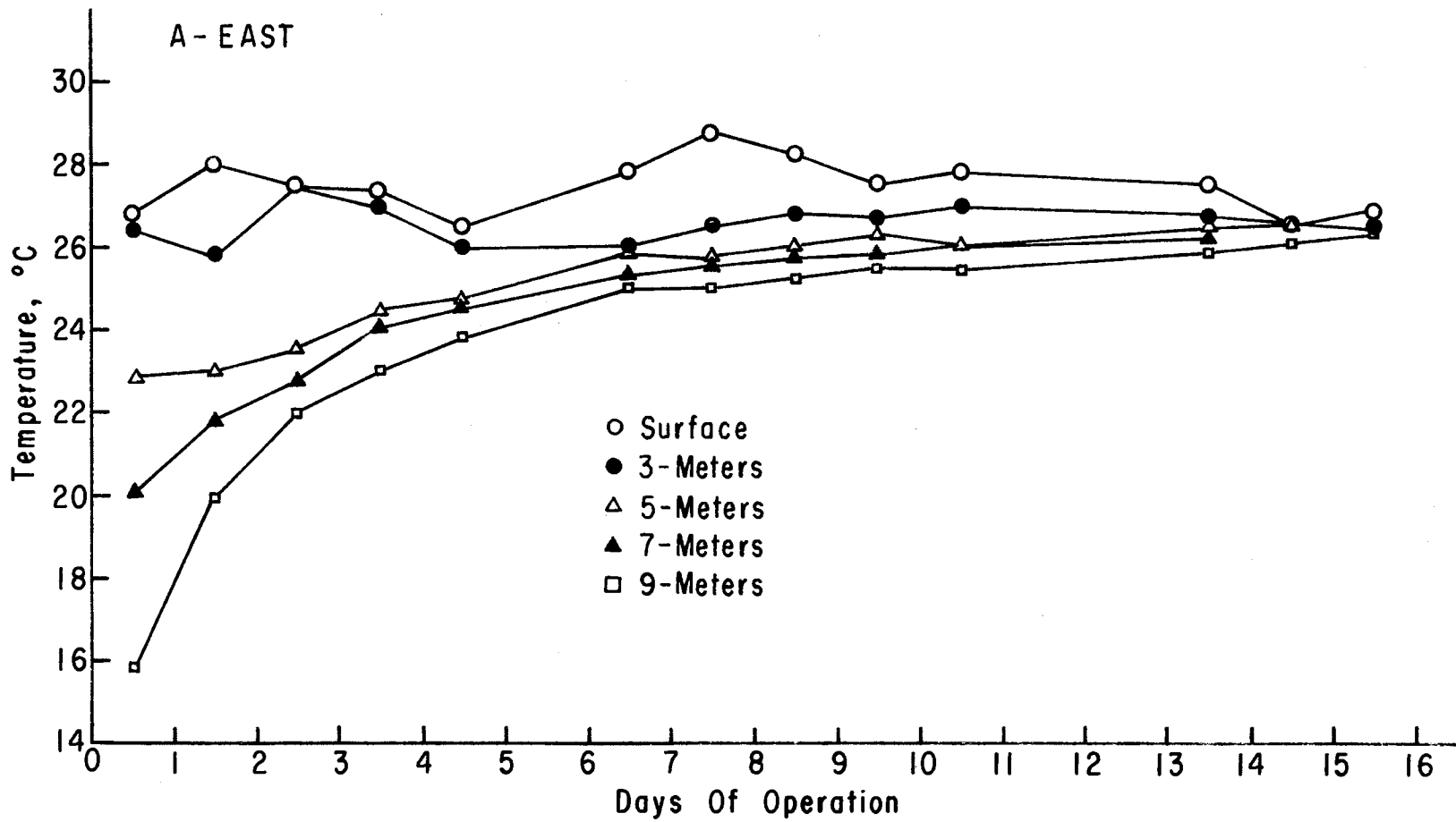

Figure 29. Plot of Temperature Versus Time at Station A-East

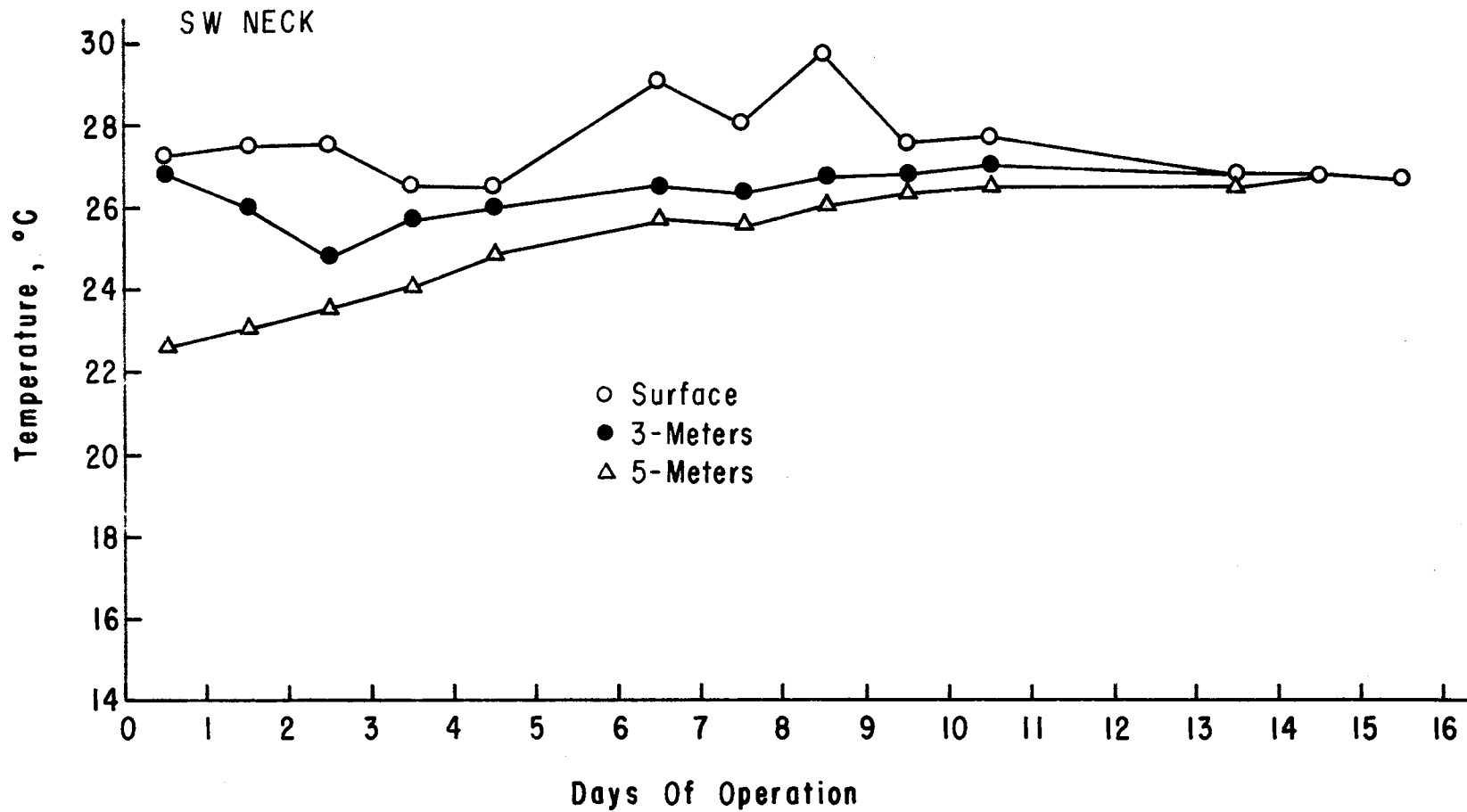

Figure 30. Plot of Temperature Versus Time at Station SW Neck

this warming was at an exponential rate. Similarity in the shape of the curves can be seen at different locations. Station A-East was located about 30 meters north of the pump and station SW-Neck was about 600 meters to the southwest.

The changes in the DO regime are even more pronounced. Figure 31 shows the DO profiles for one of the same stations as the temperature profiles. On June 29 the surface DO was 8.0 mg/l and DO was zero below 5 meters. By July 13 the surface condition was similar but the DO dropped from 7.2 mg/l at 3 meters to 0 at 4 meters. Readings of DO taken at sunset ranged as high as 10 to 11 mg/l. at the surface. This highly supersaturated condition was due to the high rate of photosynthesis occurring. On August 1, the first day that the temperature profile was entirely uniform the DO profile ranged from 3.8 mg/l at the surface to 1.1 mg/l at the bottom. This was a significant reduction in the surface DO. The cause was probably the mixing of the surface water with the high BOD water from the hypolimnion. Even more significant was the presence of DO at all depths. A general increase in DO had occurred by August 16. The DO concentration was relatively uniform although not saturated on September 5. More time was required to raise DO to a uniform level at all depths than was necessary to make the lake isothermal. This was probably due to the high organic load that was present in Ham's Lake.

Figures 32 and 33 illustrate how the DO varied with depth after pumping began. Oxygen could be found at the lower depths at the pump earlier than at other locations. A longer period of time was required to obtain uniform oxygen readings than was necessary to get an isothermal condition.

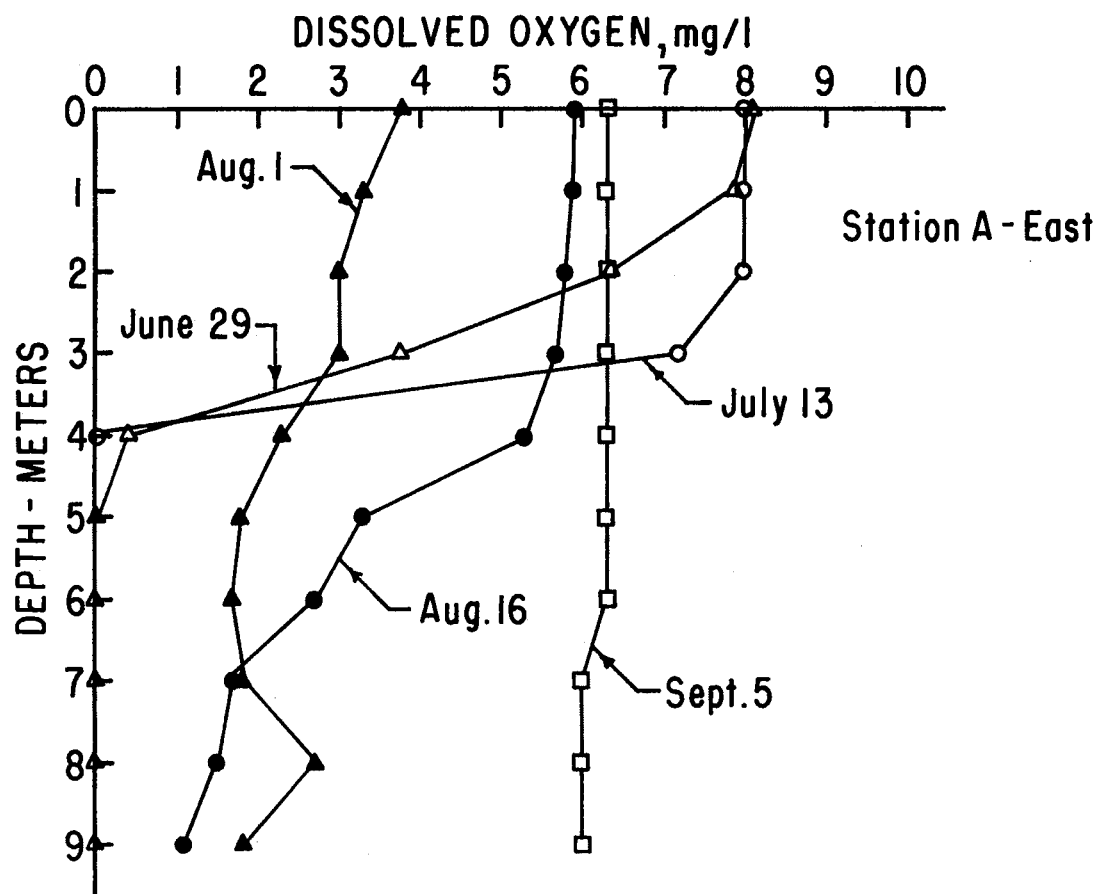

Figure 31. Typical Dissolved Oxygen Profiles

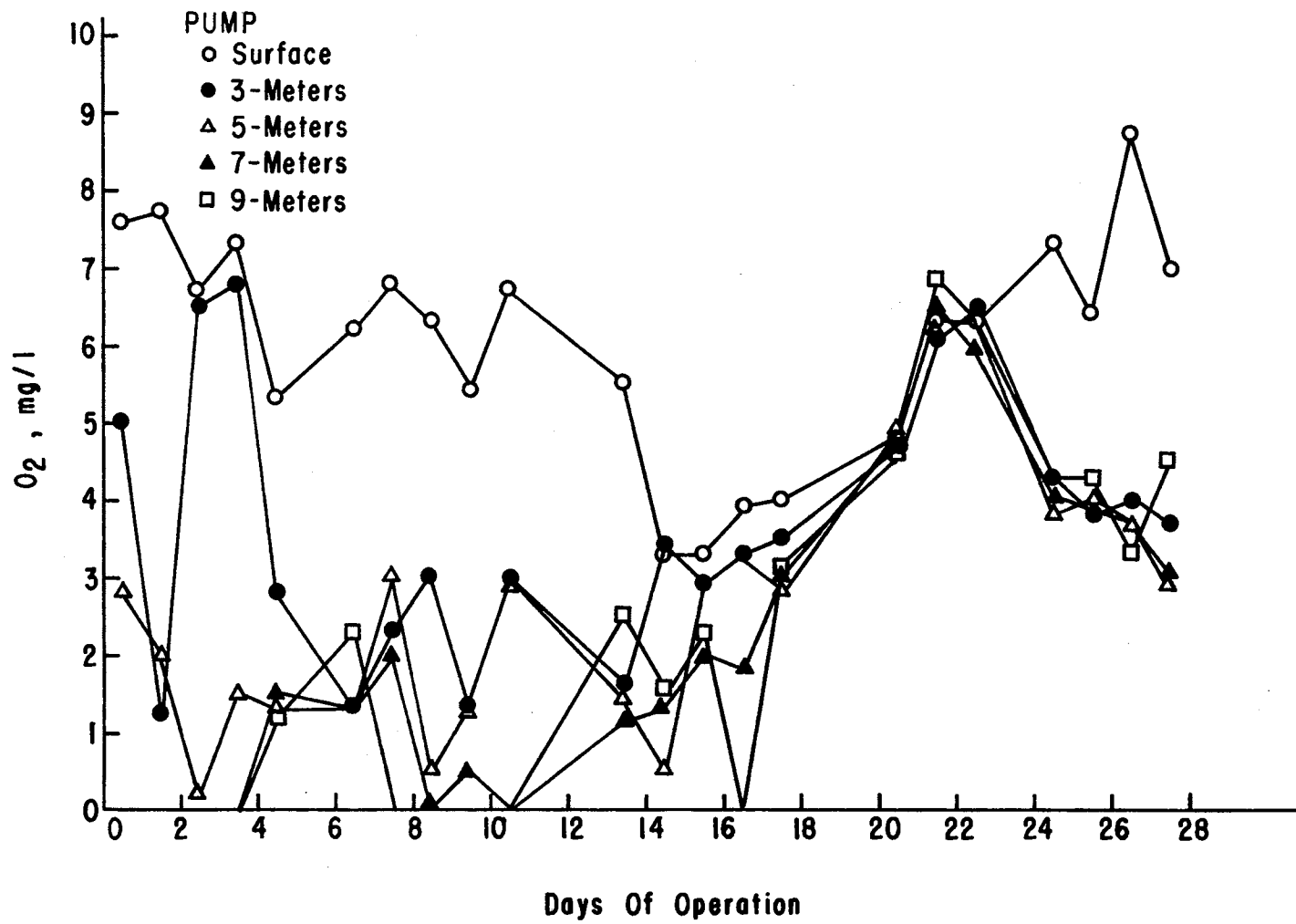

Figure 32. Plot of Dissolved Oxygen Versus Time at Pump

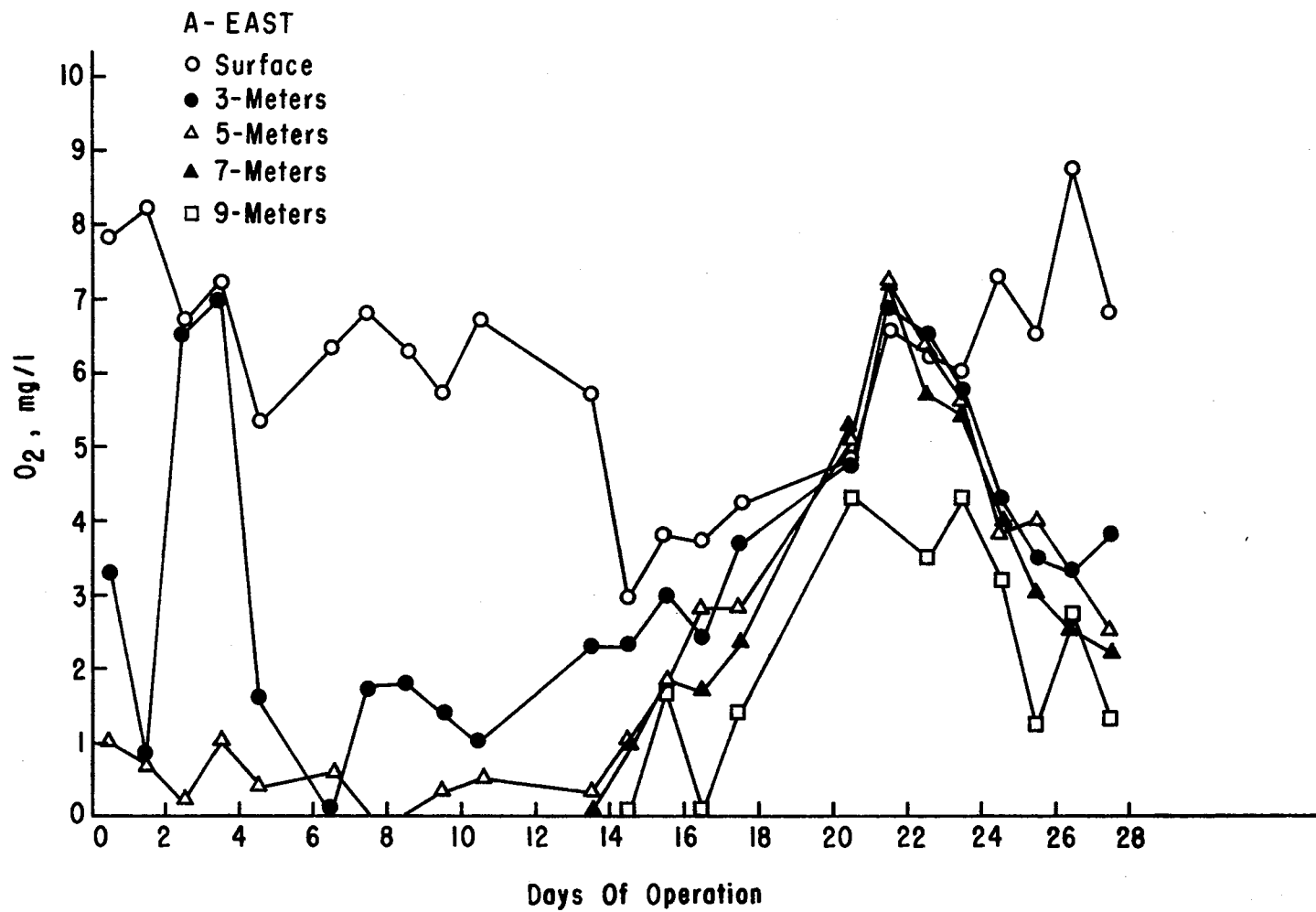

Figure 33: Plot of Dissolved Oxygen Versus Time at Station A-East

The raw data of temperature and DO profiles were too numerous to make direct analysis of day to day changes practical. A computer program, Table III, was developed that was capable of reducing these data to a few parameters for each date. The parameters calculated were the lake's elevation, volume and surface area, the weighted average temperature, the weighted average DO, the total mass of DO and the stratification index. The weighted averages were calculated taking into account the volume at each particular level.

The changes in the weighted average temperature and DO and the stability index are graphed in Figure 34. The broken line on July 13 indicates the last day that no pumping occurred. The solid line July 16 indicates that day on which continuous pumping commenced.

The average temperature was observed to increase both before and after mixing. The lake did not begin to cool until late August. Although the surface temperature cooled some after mixing, the average temperature increased to a higher temperature than if the lake had not been mixed. The heat budget of the lake was increased. The reason is that the hypolimnion water had been warmed considerably.

The average DO generally varied between 5.0 and 6.5 mg/l before mixing. Unfortunately almost all of this was at the surface. When mixing began the average DO began to drop until it reached a low of 2.85 mg/l on July 31. This drop was probably due to the oxidation of the high BOD water brought up from the bottom. At no time was the surface DO near zero nor was a fish kill observed. The average DO built back to its level before mixing, but DO was mixed throughout the water column.

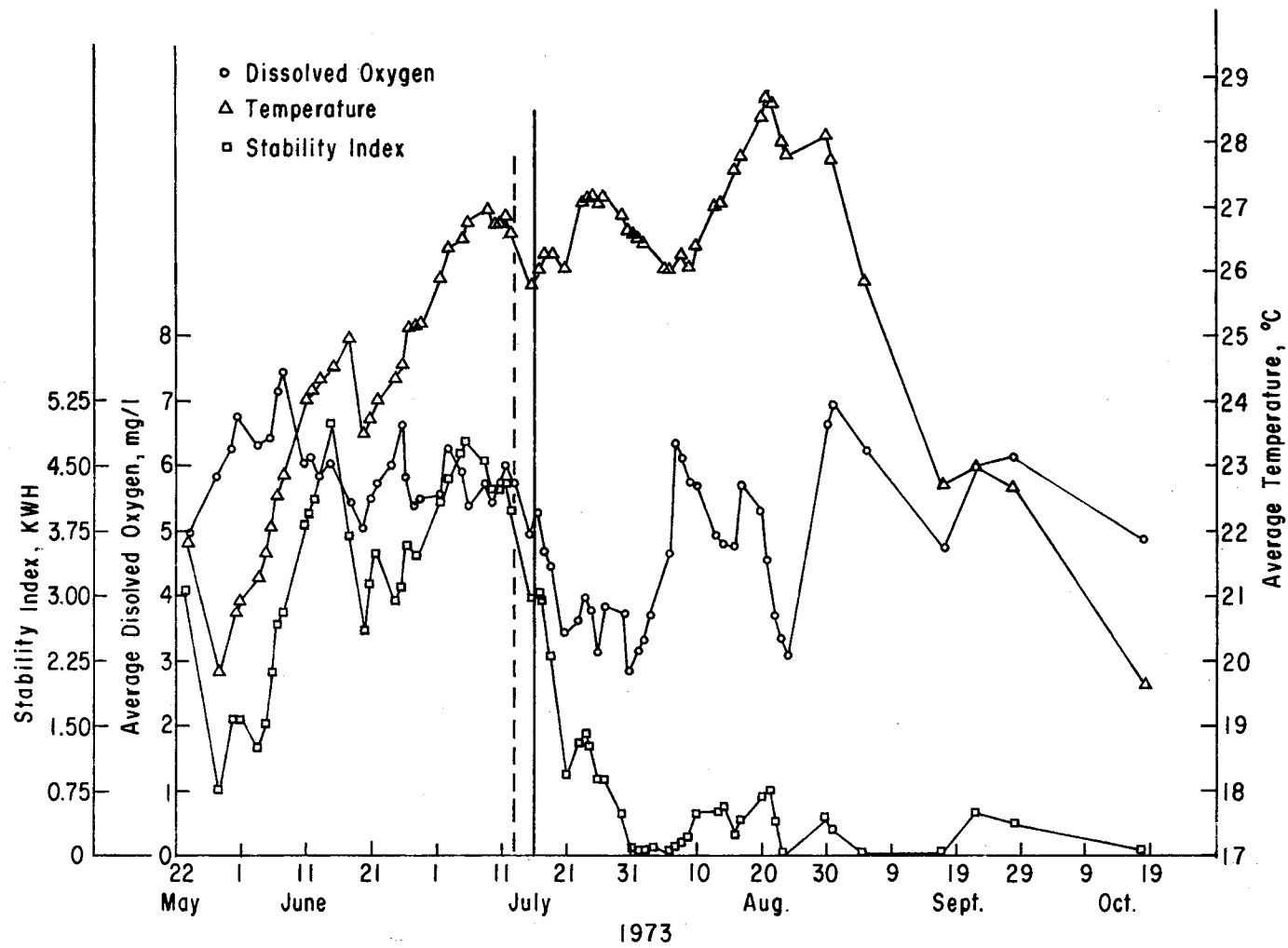

Figure 34. Plots of Average Dissolved Oxygen, Average Temperature, and Stability Index Versus Time

The stability index is a measure of the resistance to mixing of a stratified lake. The stability index generally tended to increase during the warming period in June and early July. Variations in the index occurred from day to day generally caused by the wind. On a still day the top meter of water warmed up more than it did on a windy day when the top 2 or 3 meters were usually well mixed. After pumping began the stability index dropped sharply. By August 1 the stability index was 0.033 KWH compared with 3.95 KWH on July 13 before mixing began. After August 1 the index increased on some days, usually because of the calm winds. Readings taken at dawn usually showed a nearly constant temperature, indicating that the index dropped nearly to zero at night.

pH, CO₂ and Alkalinity

The plots of the pH profiles for June 25 and July 13 on Figure 35 are typical of the enriched lake. A lake rich in nutrients is capable of supporting a large crop of plankton. In the surface layers of the lake exposed to sunlight, algae, carbon dioxide and water combine together by photosynthesis to produce oxygen and sugar. Little photosynthesis occurs in the hypolimnion since light cannot penetrate to that depth. Respiration still occurs there releasing CO₂. Since the hypolimnion cannot mix, the CO₂ is trapped. Carbon dioxide dissociates in water to form carbonic acid. This reaction results in a pH decrease as the CO₂ concentration increases. At about pH 8.3, the phenolphthalein end point, no CO₂ remains dissolved in water. Figure 36 shows that before mixing, CO₂ disappeared from the surface and increased in the hypolimnion. This was accompanied by a pH generally above 8.5 at the surface. When CO₂

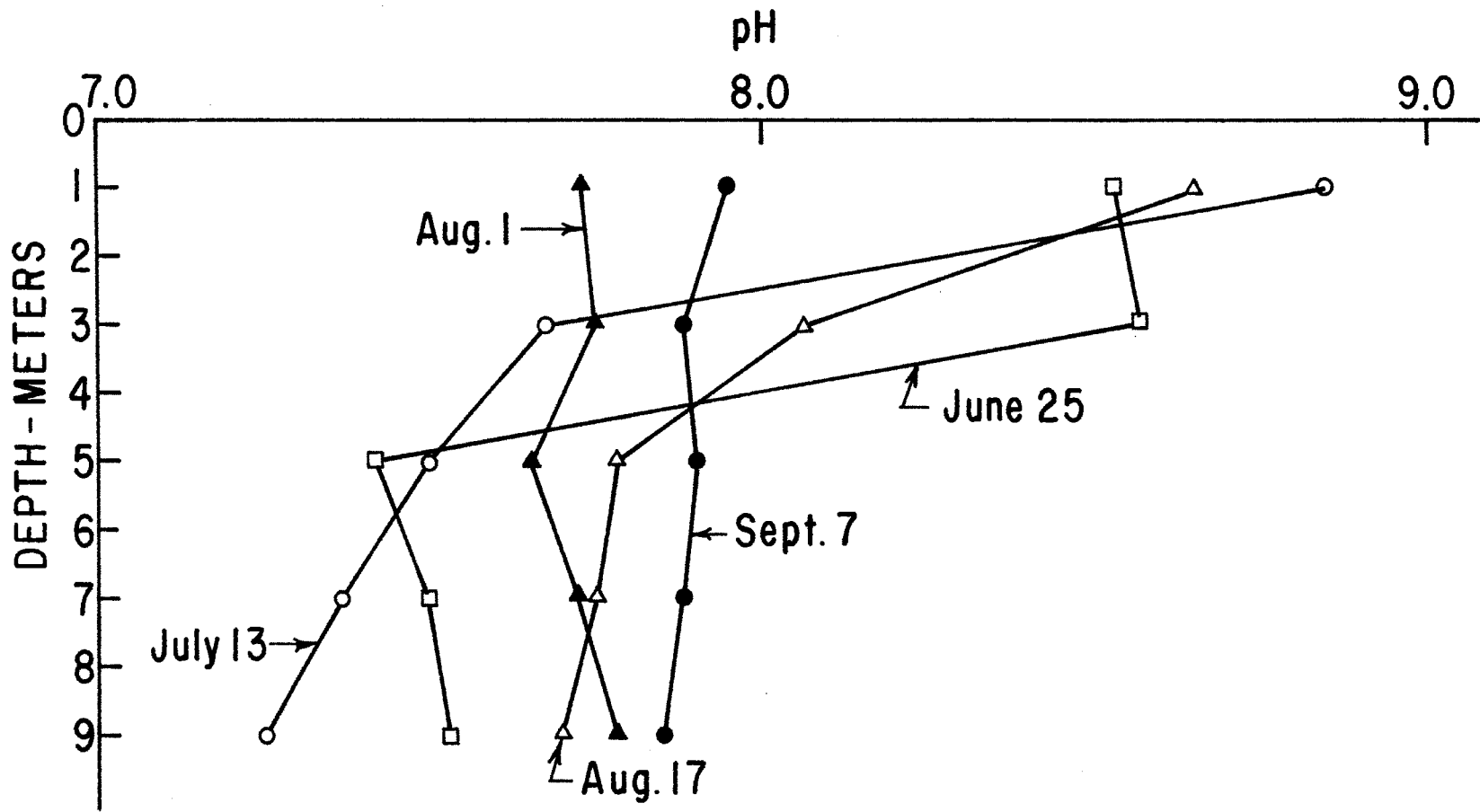

Figure 35. Typical pH Profiles

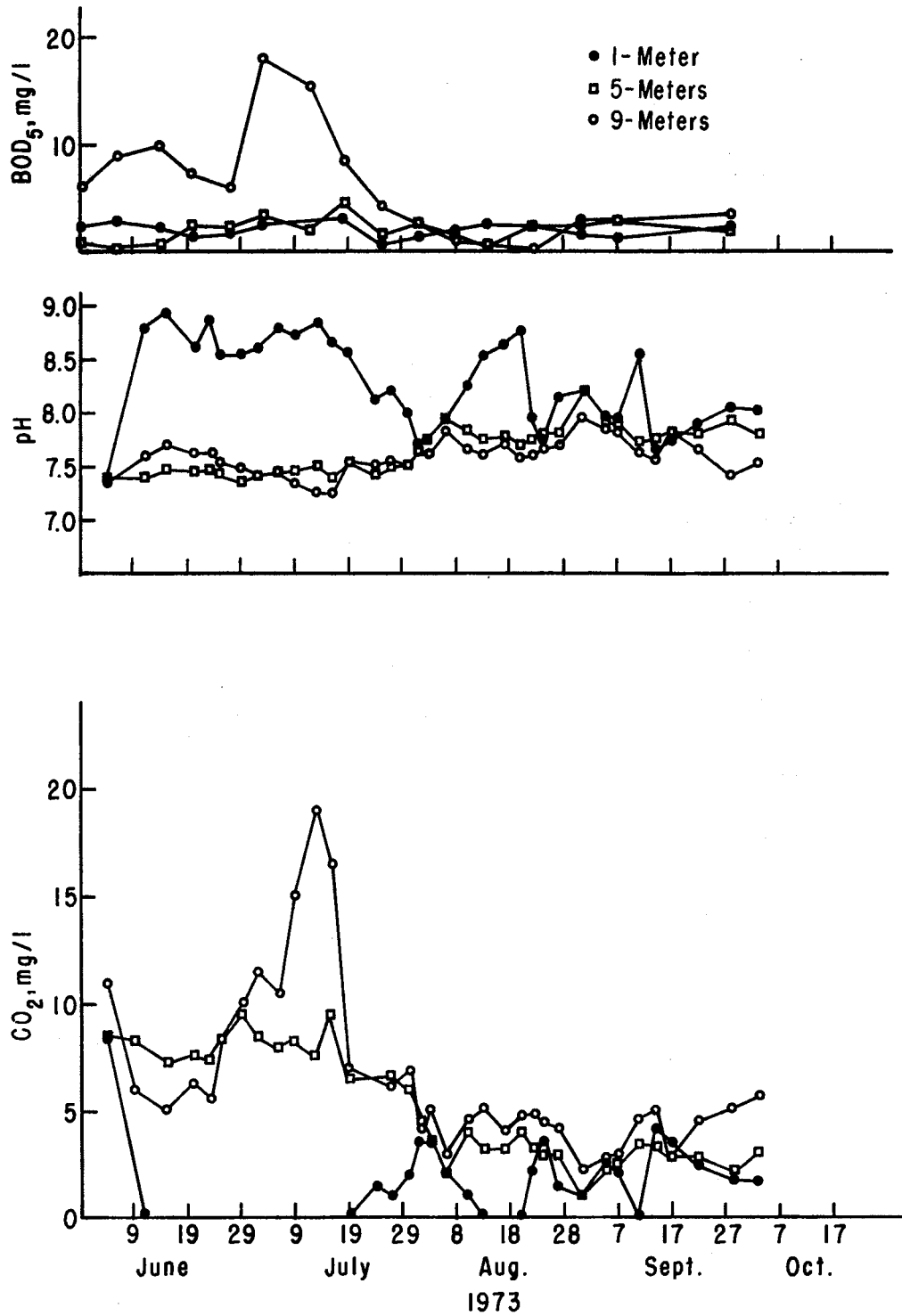

Figure 36. Plots of BOD₅, pH and CO₂ Versus Time at Station A-East

disappears photosynthetic algae use bicarbonate as a carbon source.

The immediate effect of mixing was the reduction of pH in the surface water and the increase of pH near the bottom. This was accompanied by the return of free CO_2 to the surface and reduction of CO_2 near the bottom. By August 1 the pH was nearly uniform at about 7.7. Twice the pH did rise above 8.5, the result of a bloom, but it fell back below 8.0 afterward.

For a month before mixing, carbonate alkalinity was present at 1 meter and sometimes at 3 meters. As stratification became more intense total alkalinity in the hypolimnion increased. Pumping lowered the total alkalinity in the hypolimnion in a few days. A general decrease in the total alkalinity throughout the water column developed in the long run. Carbonate alkalinity was reduced to zero by July 30. Only on two occasions afterwards was carbonate alkalinity present and then only for a short time.

BOD₅

The most striking feature of the BOD₅ profiles in Figure 37 was the increase in BOD₅ in the hypolimnion during stratification and the rapid decrease after mixing. Figure 36 shows that relationship among BOD₅, pH and CO_2 . The sharp increase in BOD₅ at 9 meters before mixing was accompanied by an increase in CO_2 and a slight decrease in pH. Mixing allowed the organic material near the bottom of the lake to oxidize since oxygen was then available. The CO_2 stored in the hypolimnion and the CO_2 produced by the oxidation of organic matter resulted in a more uniform distribution of CO_2 throughout the water column.

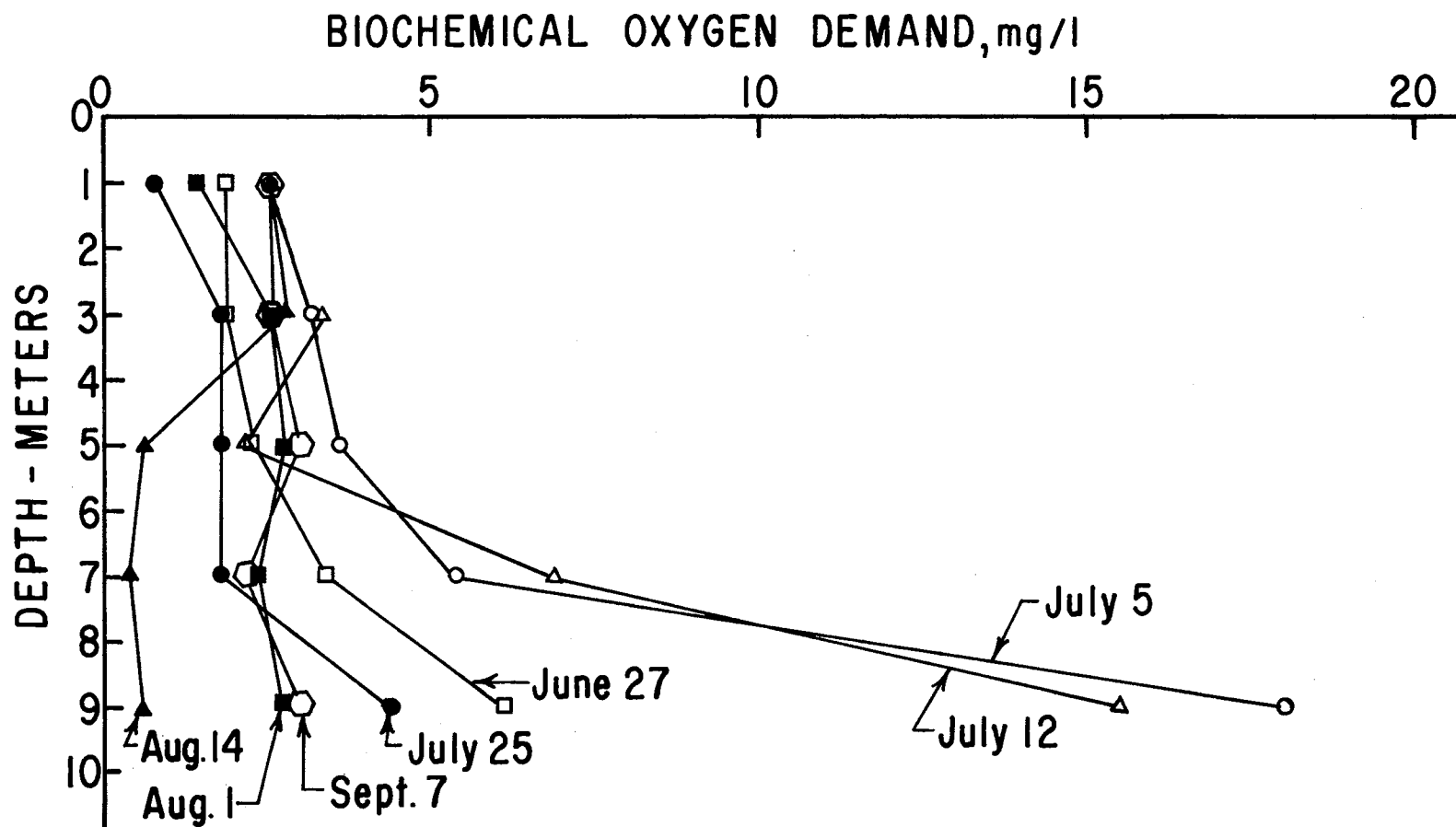

Figure 37. Typical Biochemical Oxygen Demand Profiles

The availability of CO₂ also resulted in the reduction of pH in the surface water.

Specific Conductance

Specific conductance yields a measure of a water's capacity to convey an electric current. This property is related to the total concentration of the ionized substances in a water and the temperature at which the measurement is made (24). Specific conductance followed a pattern similar to other physical-chemical parameters. Figure 38 illustrates how specific conductance was stratified before mixing was begun on July 16. By July 24 the stratification was less sharp and on August 3 conductance was uniform top to bottom. The data in Table VII of the appendix shows a reduction of conductance in August and September. This was due to the heavy inflow from increased rains during that time. The unusually low conductance and alkalinity figures for September 28 at 7 and 9 meter depths were probably due to heavy rainfall September 26 that raised the lake level about 0.3 meters.

Turbidity

Surface turbidity (Figure 39) measurements showed little change due to the mixing. The range was between 10 and 21 Jackson turbidity units. Usual readings were in the mid teens both before and after mixing. The increase in turbidity September 14 was due to heavy runoff from a rain storm.

Biological

Collection of biological data was limited to collection of plankton

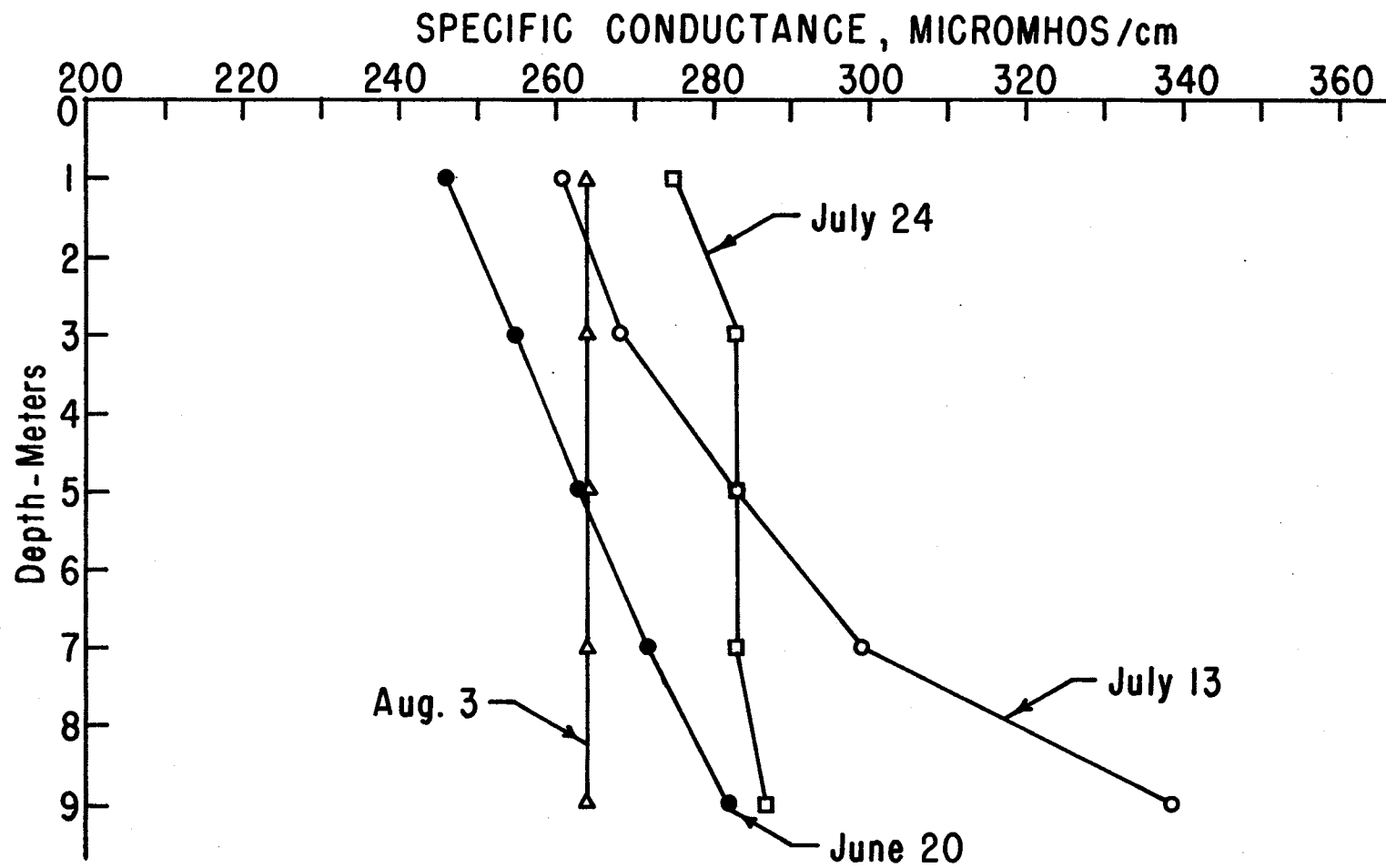

Figure 38. Specific Conductance Profiles

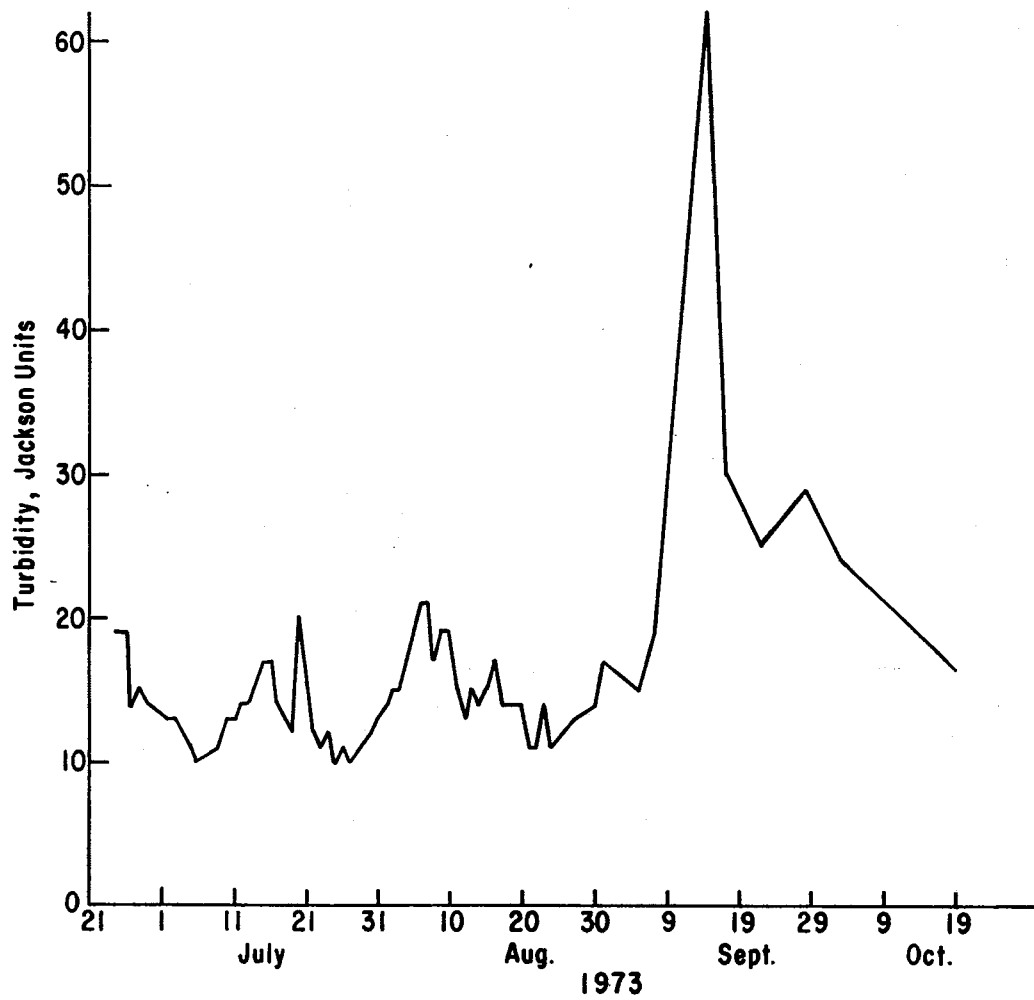

Figure 39. Plot of Surface Turbidity Versus Time

samples. No analysis of fish behavior or production was made. The identification and counting of the plankton samples was done by a biologist. The results are given in the Appendix.

For initial analysis the plankton was divided into four groups: green algae (Chlorophyta), blue-green algae (Cyanophyta), flagellates (Euglenophyta and Pyrrophyta) and diatoms (Chrysophyta). Numbers of these groups graphed versus time are given in Figure 40. The numerical scale is logarithmic.

Early in June flagellates especially *Euglena* predominated. Blue-greens hit a small peak June 29 and then dropped until July 6. Their numbers began building before pumping began and peaked July 19 with bloom proportions. The blue-greens dropped sharply and did not build back until a month later. Flagellates again hit a brief peak near the end of July. On August 6 all types of plankton except diatoms had very low counts. Diatoms began a quick growth rate and maintained high numbers for about a month and a half. *Cyclotella* was the most common diatom but *Melosira* became more important late in the season. Blue-greens built up to bloom proportions again in late August, and remained high through September.

The expected shift in predominance from blue-green to green algae apparently did not occur. Comparison of the counts observed showed that blue-green algae were more numerous. Some of this may be misleading since some of the green algae forms had cell volumes larger than the blue greens, and could still have a similar biomass even with smaller numbers (26). There were changes in the types of blue-green algae present (Figure 41). Before mixing *Anabaena* and *Microcystis* (*Anacystis*) predominated. At the onset of mixing *Dactylococopsis*

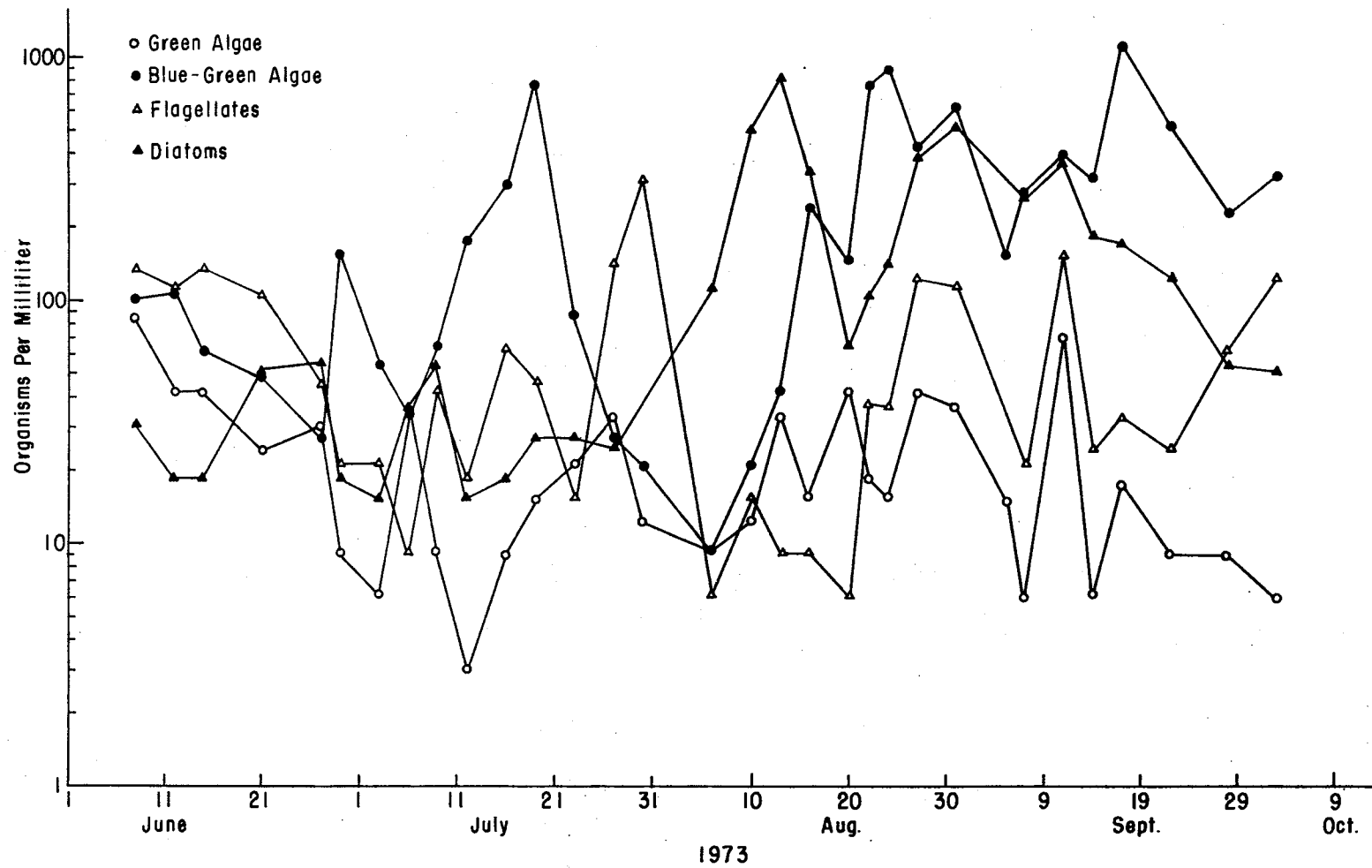

Figure 40. Plot of Plankton Counts Versus Time

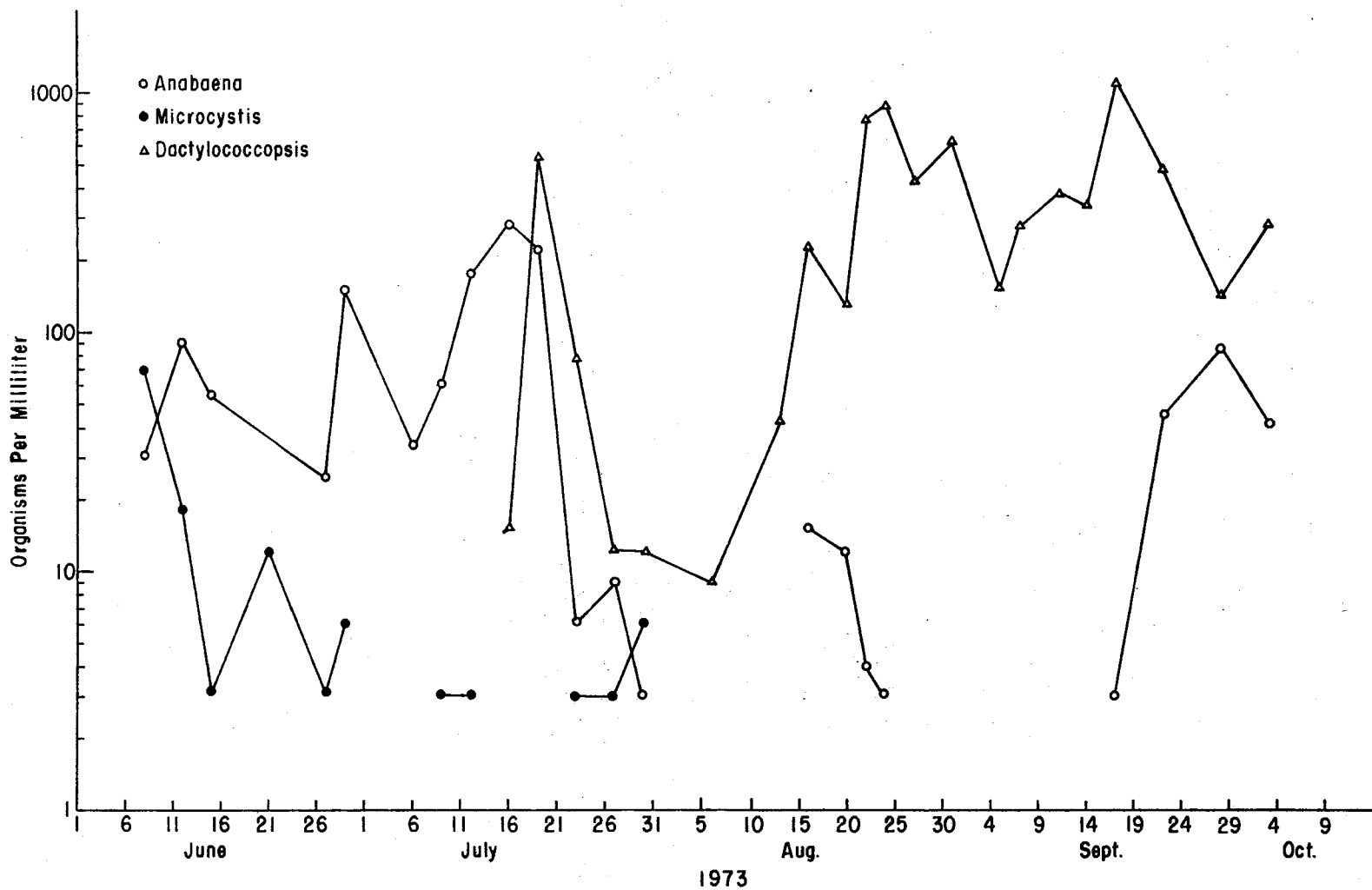

Figure 41. Plot of Predominant Blue-Green Algae Counts Versus Time

appeared and became the dominant blue-green. Sometimes it was present in numbers as high as 1,130,000 per liter. Frequently both *Microcystis* and *Anabaena* are mentioned as being "nuisance" algae. After mixing both of these algae were reduced in number and sometimes disappeared. *Dactylococcopsis* has not been identified as being as troublesome as *Anabaena* or *Microcystis*.

Analysis of Pump

Pump Operation

Originally it had been thought that the diffuser was necessary not only to reduce head loss but also as a conduit to move the pumped surface water to the hypolimnion. The power and flow rate measurements were first taken without the diffuser. Before installing the diffuser, the pump operated during hydraulic testing for 9 1/2 hours on July 14. Even though the exit of the pump was only 1.8 meters below the water surface, apparently the pumped water had enough energy to penetrate the thermocline located between 3 and 4 meters depth. That night when the pump was shut off the hypolimnion water temperature had risen about 1° C. Earlier observations showed that the hypolimnion temperature did not change prior to pumping.

The pump was continuously operated without the diffuser from 9:00 p.m. July 16 until 1:30 p.m. July 23. The pump was operated using the 18-tooth pulley with timing belt. The rotation was 37 rpm, the flow rate 0.666 cubic meters per second and the power 261 watts. The rigid metal diffuser was installed during the afternoon of July 23. The 18-tooth pulley was still used but the flow rate increased to 0.773 cubic meters per second and the power decreased to 194 watts. On August 2

a V-belt drive system was installed. This drive rotated the propeller at about 44 rpm.

The V-belt drive was used during ordinary operation because of the increased life of the belts. The timing belts were used earlier to obtain a given speed ratio and were used in calculating the power calibration curves (Figure 17).

Analysis of Pump Design

Comparison of the power and flow rate characteristics for the pump are shown in Figure 42. Data for the Quintero pump are for conditions with and without a flexible fabric diffuser (3). The diffuser dimensions used are 4.88 meters long with an entrance of 1.07 meters diameter and an exit of 2.13 meters diameter. The rigid metal diffuser had the same dimensions. The Quintero data were obtained using a propeller blade with less pitch but faster rotation.

At a constant 373 watts compare the flow rates for the four conditions in Figure 42. Using the Quintero data there is a 32% increase in flow due to the diffuser. The same 32% increase was found using the Steichen data. However, comparing the two conditions both with and without the diffuser, there is a 49% increase in the Steichen data. This would indicate that there was little improvement in efficiency due to the rigid metal diffuser compared with the plastic fabric diffuser used by Quintero. All of the improvement could apparently be explained by using the different propeller blade.

A similar comparison was made at 224 watts. The results were not as uniform. The fabric diffuser resulted in a 24% improvement while the metal diffuser showed a 33% improvement. Using the different

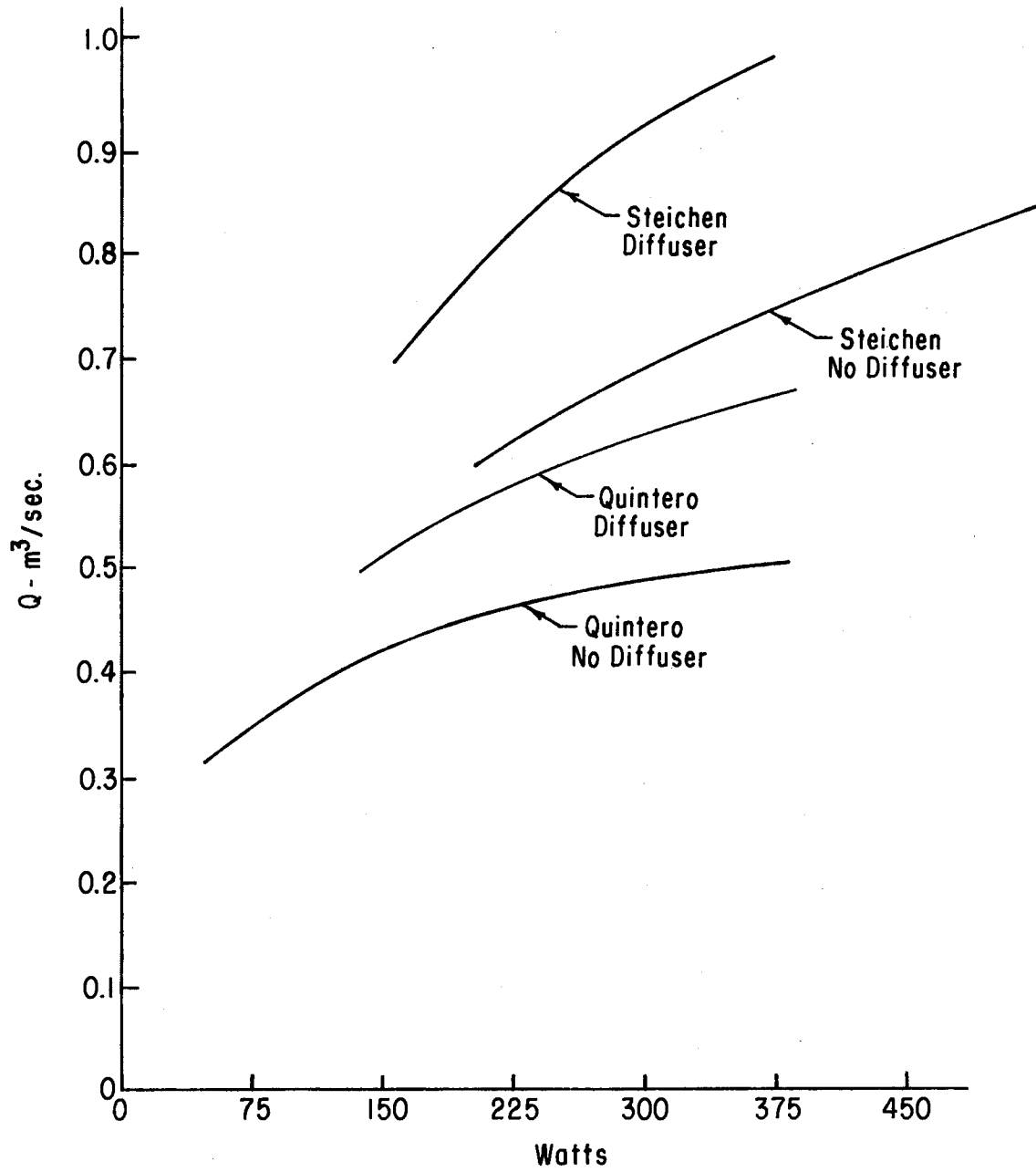

Figure 42. Flow Rate Versus Power Curves for Pump

propeller increased the flow 33% without a diffuser and 42% when the diffuser was used.

At the lower flow rate, the rigid diffuser appeared to be a little more efficient. The propeller, with sharper pitch and which rotated slower, showed a definite improvement in efficiency at all powers. The improvement was greatest at the higher power requirements. At 373 watts, which is a good operating range for this pump, there was no difference in the effectiveness of the two diffusers. Since a fabric diffuser is much easier to build and install, a fabric skirt would be a good choice for a future pump.

Calculation of the theoretical flow rate of the propeller was made using the measured chord angle of the blade and assuming stationary water. This theoretical flow rate of $0.988 \text{ m}^3/\text{rev}$ compared with $1.24 \text{ m}^3/\text{rev}$ when the pump was operated at 48 rpm with the diffuser attached. This is a 25% increase in flow rate over the theoretical. One probable explanation is that the flow rate is more strongly affected by the exit angle of the blade rather than the chord angle. This exit angle varied from 59 degrees at the hub to 37 degrees midway and 35 degrees at the tip. The theoretical flow rate calculated using the exit angle is $1.54 \text{ m}^3/\text{rev}$. Another factor was that the water was not stationary.

Pre-whirl is the term referring to the rotation of the fluid before the impeller. Pre-whirl can be either positive (I) if rotation is in the same direction as the impeller or negative (II) if in the opposite direction (27). The angle α_1 is not then a right angle. Figure 43 is the inlet velocity triangle for a pump with pre-whirl. The peripheral velocity of the impeller is ω_1 , the inlet velocity of the fluid is c_1 , while w_1 is the relative velocity. Positive pre-whirl reduces the

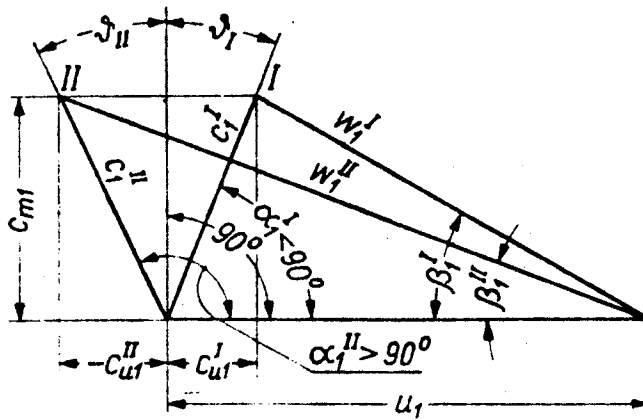

Figure 43. Inlet Velocity Triangle for a Pump with Pre-whirl (27)

relative velocity which in turn reduces the theoretical head and allows an increase in flow rate.

The current meter used a component propeller which measures the axial speed component of oblique water currents within an angle of deviation up to 30° . Since the flow is spiraling a rotating current meter will be affected by it. The velocity indicated by the current meter was low because the current meter rotated in the opposite direction of the pump. The error was probably less than 10 percent.

Effectiveness of Pump

The best way to measure the effectiveness of a destratification device is to measure the destratification efficiency defined in Equation (2-2). Daily measurements of stability index are given in the Appendix. For the first data analyzed the pump operated without the diffuser for 170 hours and used 44.4 KWH of energy. During this time the stability index dropped from 3.95 KWH to 1.30 KWH. The destratification efficiency was equal to 6.0%

By extending the period of analysis to August 1, when the lake was fully circulating, another efficiency can be calculated. The pump was operated for a total of 377 hours and used 84.5 KWH. The stability index on August 1 was 0.033 KWH. The destratification efficiency was 4.6%

Table II compares destratification efficiency for several other devices. This pump was found to be a very efficient destratification device in comparison. Several days were required to totally mix the lake. This can be an advantage since a nearly instantaneous overturn is not usually desired. This device would also be useful as a stratification prevention device, if operation is begun before the lake stratifies.

TABLE II
COMPARISON OF VARIOUS DESTRATIFICATION EFFICIENCIES

Lake	Dates of Mixing	Method	Volume Ha.- M.	Surface Area Ha.	Maximum Depth M.	Destratification Efficiency %
Ham's	7/16 - 7/23/73	Mechanical Pump	115	40	9	6.0
	7/16 - 8/ 1/73					4.6
Roberts	23 hours	Diffused Air	121	28	9	0.14
	74 hours					0.04
	144 hours					0.03
Boltz	8/ 6 - 9/10/65	Mechanical Pump	358	39	19	0.2
	6/ 2 - 6/ 7/66	Diffused Air				1.5
Falmouth	6/10 - 6/15/66	Diffused Air	567	91	13	0.9

CHAPTER VI

SUMMARY AND CONCLUSIONS

The objectives of this study were to: (1) Determine the effect of the pump's operation on the water quality parameters of a stratified lake; (2) Optimize design for minimum head loss, construct and evaluate a rigid diffuser for the lake destratification pump; and (3) Determine the relationships of shaft power, RPM and pump flow rate both with and without the diffuser.

Ham's Lake, near Stillwater, Oklahoma, was chosen as the site of this experiment. The water quality parameters observed were: temperature, dissolved oxygen, turbidity, pH, alkalinity, conductivity and biochemical oxygen demand. Composite algae samples were also taken. The lake was allowed to stratify. Beginning July 16 the pump was operated for one week without the diffuser. The rigid diffuser was installed and the pump was then operated continuously until late October, when natural fall mixing was underway.

Measurements of the pump's power input, shaft RPM and flow rate were taken both with and without the diffuser attached. Pulleys were changed on the motor, varying the shaft RPM.

Conclusions

1. Within two weeks the pump completely destratified the lake thermally.

2. A longer period of time was necessary to destratify dissolved oxygen than was necessary for thermal destratification.
3. Although there were some changes in algae species predominating in the lake, there was no real shift from blue-green to green algae predominance.
4. The pump was capable of destratifying the lake without the diffuser attached. The destratification efficiency during this period of 7 days was 6.0%.
5. Fifteen days of operation were required to lower the stability to nearly zero. The destratification efficiency for this period was 4.6%. Destratification of all physical-chemical parameters was observed.
6. No significant improvement in diffuser efficiency was found in comparing the rigid metal diffuser with the flexible fabric diffuser.
7. Use of the propeller with a pitch varying from 44° at the hub to 20° at the tip resulted in as much as 49% more flow at the same power as a propeller with pitch from 10° to 20° .

Recommendations for Further Study

1. A long-term biological study of the effect of lake destratification should be conducted in various geographical regions.
2. Model studies are necessary to determine the proper dimensionless parameters needed to fit pump design to a lake.
3. Design and operate a large-scale model on a larger and deeper lake.

4. Consider operating a pump powered by the wind, so that fuel or electricity would not be needed in an isolated place.

SELECTED BIBLIOGRAPHY

- (1) Leach, L. E., et al. Induced Hypolimnion Aeration for Water Quality Improvement of Water Releases. EPA, Water Pollution Control Research Series, No. 16080. Washington: GPO, 1970.
- (2) Quintero, J. E. and J. E. Garton. "A Low Energy Lake Destratifier." Trans. of the Am. Soc. of Agr. Engr., Vol. 16, No. 5 (1973), pp. 973-978.
- (3) Quintero, J. E. "A Low Energy Lake Destratifier." (Unpub. Ph.D. Thesis, Oklahoma State University, Stillwater, Oklahoma, May, 1973).
- (4) Hutchinson, G. E. A Treatise on Limnology. Vol. 1. New York: John Wiley & Sons, 1957.
- (5) Ruttner, F. Fundamentals of Limnology. Third Edition. Toronto: University of Toronto Press, 1963.
- (6) Symons, J. M., et al. "Mixing of Water Supply Reservoirs for Quality Control." Journal Am. Water Works Asst., Vol. 62, No. 5 (1970), pp. 322-334.
- (7) Hutchinson, G. E. "Eutrophication." American Scientist, Vol. 61, No. 3 (1973), pp. 269-279.
- (8) Duffer, W. R. and C. C. Harlin, Jr. Changes in Water Quality Resulting from Impoundment. EPA, Water Pollution Control Research Series, No. 16080. Washington: GPO, 1971.
- (9) Fruh, E. G. "The Overall Picture of Eutrophication." Journal Water Pollution Control Federation, Vol. 39, No. 9 (1967), pp. 1,449-1,463.
- (10) Haynes, R., "Some Ecological Effects of Artificial Circulation on a Small Eutrophic New Hampshire Lake." (Unpub. Ph.D. thesis Univ. of New Hampshire, Durham 1971.) In Toetz, Summerfelt and Wilhm. "Biological Effects of Artificial Destratification in Lakes and Reservoirs -- Analysis and Bibliography." Bureau of Reclamation Report REC-ERC-72-33, U. S. Dept. of the Interior, Denver, Colorado, 1972.

- (11) Leach, L. E. and C. C. Harlin, Jr. Induced Aeration of Small Mountain Lakes. EPA, Water Pollution Control Research Series, No. 16080. Washington: GPO, 1970.
- (12) _____ "Artificial Destratification in Reservoirs." Journal, American Water Works Association, Vol. 63, No. 9 (1971), pp. 597-604.
- (13) Barnett, R. H. "Reservoir Destratification Improves Water Quality." Public Works, Vol. 102, No. 6 (1971), pp 60-65.
- (14) King, D. L., "The Role of Carbon in Eutrophication," Journal, Water Pollution Control Federation. Vol. 42, No. 12 (1970), pp. 2,035-2,051.
- (15) Shapiro, J. "Blue-Green Algae: Why They Become Dominant." Science, Vol. 179, No. 4071 (1973), pp. 382-384.
- (16) Toetz, D., Wilhm, J. and Summerfelt, R., "Biological Effects of Artificial Destratification in Lakes and Reservoirs -- Analysis and Bibliography." Bureau of Reclamation Report REC-ERC-72-33, U. S. Dept. of Interior, Denver, Colorado, 1972.
- (17) Speece, R. E. and R. Orosco. "Design of U-Tube Aeration Systems." Journal Sanitary Engineering Division, ASCE, Vol. 96, No. SA-3 (1970), pp. 715-725.
- (18) Bernhardt, H., "Aeration of Wahnback Reservoir Without Changing the Temperature Profile." Journal, American Water Works Association, Vol. 59, No. 8 (1967), pp. 943-964.
- (19) Hooper, F. F., et al. "An Experiment in the Artificial Circulation of a Small Michigan Lake." Trans. Am. Fish Soc., Vol. 82 (1953), pp. 222-241.
- (20) Davies, J. T. Turbulence Phenomena. New York: Academic Press, 1972.
- (21) Gibson, A. H., "On the Resistance to Flow of Water Through Pipes or Passages Having Divergent Boundaries." Trans. Roy. Soc. Edin., Vol. 48, Part 1 (1912), pp. 97-116.
- (22) Vennard, J. K. Elementary Fluid Mechanics. Fourth Edition. New York: John Wiley and Sons, 1961.
- (23) Henderson, S. M. and R. L. Perry. Agricultural Process Engineering. New York: John Wiley and Sons, 1955.
- (24) _____ Standard Methods for the Examination of Water and Wastewater. 13th Edition, Washington, D. C.: American Public Health Association, 1971.

- (25) Moore, E. W. "Graphic Determination of Carbon Dioxide and the Three Forms of Alkalinity," Journal, American Water Works Association. Vol. 31, No. 1 (1939), pp. 51-66.
- (26) Prescott, G. W. Algae of the Western Great Lakes Area. Bloomfield Hills, Michigan: Cranbrook Institute of Science, 1951.
- (27) Lazarkiewicz, S. and A. T. Trokolanski. Impeller Pumps. New York: Pergamon Press, 1965.

APPENDIXES

TABLE III
PROGRAM FOR CALCULATING STABILITY INDEX

80/80 LIST

```

00000000111111112222222233333333444444445555555566666666777777778
1234567890123456789012345678901234567890123456789012345678901234567890
CARD
1      DIMENSION T(10,10),OD(10,10),SUMT(10),SUMO(10),TAVE(10),OAVE(10)
2      $,DATE(5)
3      510 WRITE(6,500)
4      500 FORMAT(1H1)
5      KT=0
6      WRITE(6,201)
7      201 FORMAT(3X,'DATE',7X,'ELEV',8X,'VOL',8X,'AREA',6X,'AVE',8X,'AVE',4X
8      1,'OXYGEN',5X,'S.I.',7X,'S.I.')
9      WRITE(6,202)
10     202 FORMAT(15X,'FT',3X,'AC-FT',8X,'AC',6X,'TEMP',8X,'DO',7X,'KG',7X,'K
11     1G-M',6X,'HP-HR')
12     WRITE(6,600)
13     600 FORMAT(/)
14     C      N IS THE NUMBER OF STATIONS
15     C      ELEV = STAFF GAGE READING IN FEET
16     90 READ(5,16) N,(DATE(I),I=1,5),ELEV
17     16 FORMAT(I2,4X,5A2,F10.0)
18     IF(N.EQ.99) GO TO 99
19     C      I IS THE DEPTH - 1 IN METERS      J= STATION #
20     READ(5,15)((T(I,J),OD(I,J),I=1,10),J=1,N)
21     15 FORMAT(20F4.1)
22     C      CALCULATE AVERAGE TEMP AND OD FOR EACH DEPTH
23     DO 31 I=1,10
24     SUMT(I)=0.
25     SUMO(I)=0.
26     NN=0
27     DO 30 J=1,N
28     IF(T(I,J).EQ.0.) GO TO 30
29     SUMT(I)=SUMT(I)+T(I,J)
30     SUMO(I)=SUMO(I)+OD(I,J)
31     NN=NN+1
32     30 CONTINUE
33     TAVE(I) = SUMT(I)/NN
34     OAVE(I) = SUMO(I)/NN
35     31 CONTINUE
36     C      TLAKE = LAKE TEMP      USES TT
37     C      R= DISTANCE FROM SURFACE TO CENTER OF MASS OF LAKE
38     C      RXM= R * LAKE MASS
39     C      RR= DISTANCE FROM SURFACE TO CENTER OF MASS OF MIXED LAKE
40     C      VXR= VOLUME * R USED TO FIND RR
41     C      QXKG= DISSOLVED OXYGEN, KG.
42     C      AVDD = DB IN MG/ LITER
43     C      TT=0.
44     C      RXM=0.
45     C      FMASS=0.
46     C      VXR=0.
47     C      QX=0.
48     DO 50 I=1,9
49     TT=TT+ ((TAVE(I)+TAVE(I+1))/2)*VOL(ELEV,I)
50     QX=QX+((OAVE(I)+OAVE(I+1))/2)*VOL(ELEV,I)
51     RXM=RXM+(((DEN(TAVE(I))+DEN(TAVE(I+1)))/2)*VOL(ELEV,I)*(I-0.5))
52     FMASS=FMASS+(((DEN(TAVE(I))+DEN(TAVE(I+1)))/2)*VOL(ELEV,I))
53     VXR=VXR+(VOL(ELEV,I)*(I-0.5))
54     50 CONTINUE

```

TABLE III (Continued)

80/80 LIST

```

00000000111111112222222222333333333333334444444444445555555555666666666677777777778
12345678901234567890123456789012345678901234567890123456789012345678901234567890
CARD
55      TT=TT+(TAVE(10)*VOLL(ELEV,9))
56      OX=OX+(OAVE(10)*VOLL(ELEV,9))
57      TLAKE=TT/VOLL(ELEV,0)
58      OXKG=OX*10.
59      AVDD=OX/VOLL(ELEV,0)
60      RXM=RXM+((DEN(TAVE(10))*VOLL(ELEV,9))*9.5)
61      FMASS=FMASS+(DEN(TAVE(10))*VOLL(ELEV,9))
62      R=RXM/FMASS
63      VXR=VXR+(VOLL(ELEV,9)*9.5)
64      RR=VXR/VOLL(ELEV,0)
65 C    SI=STABILITY INDEX, KG-M
66      SI=(R-RR)*FMASS *1.0E7
67 C    SIHPR= STABILITY INDEX, HP-HR
68      SIHPR=(SI/1.0E7)*36.529
69      ALT=923.8 + ELEV
70      VOLUM=VOLL(ELEV,0)*8.107
71      AREAL=AREA(ELEV)
72      WRITE(6,200)(DATE(I),I=1,5),ALT,VOLUM,AREAL,      TLAKE,AVDD,OXKG,
73      *SI,SIHPR
74      200 FORMAT(1X,5A2,F8.2,F12.2,3F10.2,2F10.0,F10.4)
75      KT=KT+1
76      IF(KT.EQ.35) GO TO 510
77      GO TO 90
78      99 WRITE(6,500)
79      STOP
80      END
81 C    CALCULATES VOLUME IN HECTARE-METERS FOR GIVEN I M SLICE
82      FUNCTION VOL(ELEV,I)
83      II=I-1
84      D=((ELEV+18.2)*0.3048)-II
85      VOL1=(-0.71202*D)+(0.67526*(D**2))-(0.097973*(D**3))+(0.0118222*(D
86      $$$4))
87      D=D-1
88      VOL2=(-0.71202*D)+(0.67526*(D**2))-(0.097973*(D**3))+(0.0118222*(D
89      $$$4))
90      VOL=VOL1-VOL2
91      RETURN
92      END
93 C    CALCULATES VOLUME IN HECTARE-METERS BELOW I DEPTH
94      FUNCTION VOLL(ELEV,I)
95      D=((ELEV+18.2)*0.3048)-I
96      VOLL=(-0.71202*D)+(0.67526*(D**2))-(0.097973*(D**3))+(0.0118222*(D
97      $$$4))
98      RETURN
99      END
100     FUNCTION DEN(T)
101     DEN=0.999868508517322 D0 +(0.671760015421274 D-4*T)-(0.89302500826
102     $9373 D-5*T**2)+(0.861137053280717 D-7*T**3)-(0.616235641457997 D-9
103     $*T**4)
104     RETURN
105     END
106 C    CALCULATES SURFACE AREA IN ACRES
107     FUNCTION AREA(ELEV)
108     D= ELEV + 18.2
109     AREA=(1.00277*D) -(0.11605*D**2)+(0.0065715*D**3)-(0.00005537*D**4
110     $)
111     RETURN
112     END

```

TABLE IV
STABILITY INDEX AND OTHER LAKE PARAMETERS

DATE	ELEV M	VOL HA-M	AREA HA	AVE TEMP C	AVE DO MG/L	OXYGEN KG	S.I. KWH
MAY 24	286.92	112.3	39.4	21.8	4.9	5535.	3.06
MAY 29	286.91	111.7	39.2	19.8	5.9	6552.	0.77
MAY 31	287.00	115.4	40.2	20.7	6.3	7246.	1.60
JUNE 1	286.99	115.1	40.1	20.9	6.8	7780.	1.58
JUNE 4	286.98	114.4	39.9	21.3	6.3	7218.	1.26
JUNE 5	286.97	114.2	39.9	21.7	6.5	7375.	1.51
JUNE 6	286.97	114.2	39.9	22.0	6.5	7394.	2.10
JUNE 7	286.96	113.9	39.8	22.5	7.1	8136.	2.63
JUNE 8	286.95	113.6	39.7	22.8	7.5	8462.	2.80
JUNE 11	286.94	112.9	39.6	24.0	6.0	6809.	3.78
JUNE 12	286.93	112.7	39.5	24.1	6.1	6893.	3.93
JUNE 13	286.93	112.5	39.4	24.3	5.9	6594.	4.09
JUNE 15	286.92	112.2	39.4	24.5	6.1	6792.	4.97
JUNE 18	286.90	111.4	39.1	25.0	5.4	6049.	3.65
JUNE 20	286.90	111.4	39.1	23.5	5.1	5650.	2.55
JUNE 21	286.89	111.1	39.1	23.7	5.5	6137.	3.10
JUNE 22	286.88	110.5	38.9	24.0	5.8	6373.	3.48
JUNE 25	286.86	109.7	38.7	24.3	6.0	6620.	2.91
JUNE 26	286.85	109.3	38.6	24.6	6.6	7239.	3.11
JUNE 27	286.84	109.1	38.5	25.2	5.8	6350.	3.57
JUNE 28	286.83	108.7	38.5	25.2	5.3	5787.	3.44
JUNE 29	286.86	109.9	38.8	25.2	5.5	6013.	3.42
JULY 2	286.81	107.9	38.2	25.9	5.6	6009.	4.09
JULY 3	286.80	107.6	38.2	26.4	6.2	6722.	4.31
JULY 5	286.80	107.3	38.1	26.5	5.9	6334.	4.62
JULY 6	286.79	106.9	38.0	26.8	5.3	5704.	4.71
JULY 9	286.76	105.7	37.7	27.0	5.8	6092.	4.51
JULY 10	286.75	105.5	37.6	26.8	5.4	5732.	4.11
JULY 11	286.75	105.5	37.6	26.7	5.7	6008.	4.19
JULY 12	286.74	105.3	37.6	26.8	6.0	6304.	4.27
JULY 13	286.73	104.9	37.5	26.6	5.8	6057.	3.96
JULY 16	286.71	104.0	37.2	25.7	4.9	5127.	2.90
JULY 17	286.70	103.8	37.2	26.0	5.3	5461.	3.00
JULY 18	286.69	103.4	37.1	26.2	4.7	4856.	2.89
JULY 19	286.69	103.1	37.0	26.3	4.4	4582.	2.28

TABLE IV (Continued)

DATE	ELEV M	VOL HA-M	AREA HA	AVE TEMP C	AVE DD MG/L	OXYGEN KG	S.I. KWH
JULY 20	286.68	102.9	36.9	26.4	5.2	5381.	1.36
JULY 21	286.66	102.3	36.8	26.0	3.4	3521.	0.96
JULY 23	286.66	102.2	36.7	27.0	3.6	3695.	1.30
JULY 24	286.65	101.7	36.6	27.1	4.0	4043.	1.37
JULY 25	286.68	102.9	36.9	27.2	3.8	3909.	1.23
JULY 26	286.67	102.6	36.9	27.0	3.2	3236.	0.84
JULY 27	286.66	102.3	36.8	27.2	3.9	3949.	0.87
JULY 30	286.76	105.7	37.7	26.9	3.7	3946.	0.48
JULY 31	286.75	105.5	37.6	26.6	2.8	3005.	0.05
AUGUST 1	286.74	105.2	37.5	26.5	3.2	3325.	0.03
AUGUST 2	286.73	104.9	37.5	26.5	3.3	3478.	0.08
AUGUST 3	286.73	104.6	37.4	26.5	3.7	3883.	0.12
AUGUST 6	286.69	103.4	37.1	26.0	4.6	4796.	0.03
AUGUST 7	286.69	103.2	37.0	26.0	6.4	6589.	0.11
AUGUST 8	286.67	102.6	36.9	26.3	6.1	6261.	0.15
AUGUST 9	286.82	108.1	38.3	26.0	5.7	6203.	0.22
AUGUST 10	286.82	108.1	38.3	26.4	5.7	6130.	0.48
AUGUST 13	286.79	106.9	38.0	27.0	4.9	5233.	0.51
AUGUST 14	286.79	106.9	38.0	27.1	4.8	5096.	0.55
AUGUST 16	286.77	106.2	37.8	27.6	4.8	5051.	0.22
AUGUST 17	286.76	105.9	37.7	27.8	5.7	6038.	0.41
AUGUST 20	286.74	105.0	37.5	28.4	5.3	5562.	0.67
AUGUST 21	286.73	104.8	37.4	28.6	4.5	4734.	0.72
AUGUST 22	286.72	104.5	37.3	28.5	3.7	3866.	0.40
AUGUST 23	286.71	104.1	37.3	28.0	3.4	3505.	-0.04
AUGUST 24	286.70	103.8	37.2	27.8	3.1	3211.	-0.01
AUGUST 27	286.66	102.3	36.8	28.2	6.5	6648.	0.83
AUGUST 30	286.63	101.1	36.5	28.1	6.6	6703.	0.42
AUGUST 31	286.62	100.8	36.4	27.7	7.0	7016.	0.29
SEPT 5	286.69	103.3	37.0	25.8	6.2	6421.	0.02
SEPT 17	286.91	111.8	39.3	22.7	4.7	5261.	-0.03
SEPT 22	286.92	112.3	39.4	23.0	6.0	6702.	0.50
SEPT 28	287.21	124.5	42.4	22.7	6.1	7612.	0.35
OCT 3	287.09	119.3	41.1	23.1	7.4	8799.	0.98
OCT 18	287.09	119.3	41.1	19.6	4.8	5781.	0.05

TABLE V
AVERAGE TEMPERATURE PROFILES

DATE	AVERAGE TEMPERATURE, CELSIUS DEPTH, METERS									
	0	1	2	3	4	5	6	7	8	9
MAY 24	23.9	23.5	23.2	21.1	19.2	18.5	17.7	16.6	15.0	13.8
MAY 29	20.3	20.1	20.1	19.9	19.7	19.4	19.1	18.5	16.0	14.5
MAY 31	21.8	21.6	21.2	20.2	19.8	19.4	18.9	18.5	16.3	14.4
JUNE 1	21.7	22.0	21.3	20.5	19.9	19.6	19.2	18.6	16.6	14.8
JUNE 4	21.8	21.8	21.8	21.6	21.0	20.5	19.7	18.6	16.9	15.4
JUNE 5	22.4	22.4	22.2	22.0	21.2	20.5	19.6	18.6	17.2	15.6
JUNE 6	23.4	23.2	22.6	21.8	20.9	20.2	19.5	18.5	16.5	15.5
JUNE 7	24.2	24.1	23.1	22.0	21.0	20.0	19.5	18.4	17.2	14.9
JUNE 8	24.5	24.5	23.7	22.1	21.1	20.2	19.4	18.5	16.7	15.2
JUNE 11	25.9	26.2	26.0	22.6	21.2	20.3	19.5	18.4	16.7	15.2
JUNE 12	26.1	26.4	26.3	22.7	21.1	20.1	19.4	18.3	16.7	15.2
JUNE 13	26.5	26.8	25.9	23.1	21.2	20.2	19.4	18.4	16.6	15.2
JUNE 15	27.1	27.2	26.9	24.4	19.3	18.0	18.0	16.6	16.6	15.1
JUNE 18	26.5	26.5	26.5	26.4	22.6	20.6	19.3	18.3	16.6	15.2
JUNE 20	24.5	24.5	24.5	24.5	22.8	20.4	19.3	18.1	16.4	14.9
JUNE 21	25.3	25.2	24.8	24.3	22.4	20.1	18.9	17.8	16.2	14.9
JUNE 22	25.9	25.8	25.4	24.1	22.4	20.0	18.7	17.7	16.1	14.6
JUNE 25	25.5	25.5	25.5	25.4	24.5	20.8	18.7	17.8	16.2	14.6
JUNE 26	25.8	25.8	25.8	25.7	24.5	20.7	18.8	17.6	16.1	14.7
JUNE 27	27.0	26.6	26.3	26.0	24.6	21.0	19.0	17.8	16.0	14.7
JUNE 28	26.6	26.7	26.6	26.0	24.5	21.4	19.1	17.8	16.2	14.8
JUNE 29	26.5	26.6	26.6	25.9	24.6	21.6	19.4	17.9	16.1	14.8
JULY 2	27.8	27.7	27.6	26.8	24.6	21.4	19.0	17.4	15.9	14.6
JULY 3	28.3	28.2	28.1	27.2	24.7	21.9	19.4	17.8	15.9	14.6
JULY 5	28.6	28.6	28.4	27.0	24.5	21.6	19.0	17.6	15.8	14.6
JULY 6	28.8	28.9	28.7	27.5	24.7	21.7	19.1	17.5	15.9	14.5
JULY 9	28.8	28.9	28.8	28.4	25.2	21.8	19.1	17.5	15.8	14.5
JULY 10	28.2	28.4	28.5	28.4	25.5	22.0	19.1	17.6	15.9	14.6
JULY 11	28.4	28.5	28.4	28.1	25.4	22.0	19.4	17.5	15.9	14.5
JULY 12	28.6	28.6	28.5	28.1	25.4	22.3	19.0	17.4	15.8	14.6
JULY 13	28.1	28.2	28.2	27.9	25.7	22.1	19.3	17.6	15.8	14.5
JULY 16	26.7	26.9	27.0	26.9	25.3	22.5	20.8	18.6	16.8	15.5
JULY 17	27.1	27.4	27.4	26.6	24.1	23.1	21.5	20.0	18.1	15.8
JULY 18	27.8	27.9	27.5	25.7	23.7	23.1	22.5	21.7	20.9	20.0
JULY 19	27.4	27.5	27.4	26.0	24.1	23.5	23.2	22.8	22.5	21.3

TABLE V (Continued)

DATE	AVERAGE TEMPERATURE, CELSIUS									
	DEPTH, METERS									
	0	1	2	3	4	5	6	7	8	9
JULY 20	27.1	27.0	26.8	26.7	25.9	24.6	24.3	23.9	23.6	23.0
JULY 21	26.4	26.5	26.4	26.0	25.1	24.7	24.6	24.5	24.4	24.2
JULY 23	28.2	27.8	27.3	26.3	25.9	25.7	25.6	25.4	25.4	25.4
JULY 24	28.2	27.9	27.4	26.4	25.8	25.7	25.6	25.5	25.4	25.0
JULY 25	28.2	27.9	27.3	26.7	26.2	25.9	25.8	25.6	25.5	25.2
JULY 26	27.6	27.5	27.2	26.7	26.4	26.2	26.0	25.9	25.8	25.6
JULY 27	27.7	27.6	27.5	26.8	26.5	26.2	26.1	26.0	25.9	25.6
JULY 30	27.2	27.1	26.9	26.7	26.6	26.4	26.4	26.2	26.1	26.1
JULY 31	26.6	26.6	26.6	26.6	26.6	26.6	26.5	26.5	26.4	26.3
AUGUST 1	26.6	26.5	26.5	26.5	26.5	26.5	26.5	26.5	26.5	26.4
AUGUST 2	26.5	26.5	26.5	26.5	26.5	26.5	26.4	26.4	26.4	26.0
AUGUST 3	26.6	26.5	26.5	26.5	26.4	26.4	26.3	26.2	26.2	26.3
AUGUST 6	26.0	26.0	26.0	26.0	26.0	26.0	26.0	25.9	26.0	25.9
AUGUST 7	26.1	26.0	25.9	25.9	25.9	25.8	25.9	25.9	25.8	25.7
AUGUST 8	26.4	26.4	26.2	26.2	26.1	26.1	26.2	26.0	26.1	26.1
AUGUST 9	26.2	26.1	25.9	25.9	25.8	25.8	25.7	25.7	25.7	25.4
AUGUST 10	26.7	26.7	26.4	26.1	26.0	25.9	25.9	25.8	25.8	25.8
AUGUST 13	27.3	27.3	27.1	26.8	26.7	26.4	26.4	26.2	26.3	26.3
AUGUST 14	27.5	27.5	27.0	26.7	26.7	26.6	26.5	26.5	26.4	26.3
AUGUST 16	27.8	27.7	27.6	27.5	27.4	27.3	27.3	27.3	27.3	27.3
AUGUST 17	28.0	28.1	27.7	27.6	27.5	27.4	27.4	27.3	27.3	27.3
AUGUST 20	29.0	28.8	28.2	28.0	27.9	27.8	27.8	27.7	27.7	27.6
AUGUST 21	29.2	29.1	28.6	28.2	28.1	28.0	27.9	27.8	27.8	27.8
AUGUST 22	28.8	28.7	28.6	28.5	28.4	28.1	28.0	28.0	27.9	27.9
AUGUST 23	28.0	28.0	28.0	28.0	28.0	28.0	28.1	28.1	28.0	28.0
AUGUST 24	27.7	27.7	27.8	27.8	27.8	27.8	27.8	27.8	27.8	27.4
AUGUST 27	29.0	28.8	28.2	27.7	27.5	27.5	27.4	27.4	27.3	27.3
AUGUST 30	28.5	28.2	28.1	27.8	27.7	27.6	27.6	27.6	27.5	27.6
AUGUST 31	28.1	27.8	27.7	27.5	27.6	27.5	27.4	27.4	27.3	27.3
SEPT 5	25.8	25.8	25.8	25.8	25.8	25.8	25.8	25.8	25.8	25.8
SEPT 17	22.6	22.7	22.7	22.7	22.7	22.7	22.7	22.8	22.8	22.7
SEPT 22	23.2	23.2	23.2	23.1	22.8	22.5	22.1	22.0	21.9	21.9
SEPT 28	22.8	22.8	22.7	22.7	22.6	22.5	22.3	22.0	22.0	21.8
OCT 3	23.6	23.5	23.4	23.1	22.9	22.3	21.7	21.2	21.1	21.1
OCT 18	19.5	19.6	19.7	19.7	19.7	19.6	19.5	19.4	19.3	19.3

TABLE VI
AVERAGE DISSOLVED OXYGEN PROFILES

DATE	DISSOLVED OXYGEN, MG/L									
	DEPTH, METERS									
	0	1	2	3	4	5	6	7	8	9
MAY 24	7.2	7.1	6.8	2.8	1.9	0.6	0.0	0.0	0.0	0.0
MAY 29	6.6	6.6	6.5	6.2	5.9	4.6	3.2	1.3	0.0	0.0
MAY 31	8.2	7.9	7.1	5.6	4.8	3.3	2.2	0.6	0.0	0.0
JUNE 1	9.1	9.0	7.3	5.7	4.8	3.5	2.1	0.5	0.0	0.0
JUNE 4	7.4	7.4	7.3	6.9	5.8	3.8	1.7	0.1	0.0	0.0
JUNE 5	7.7	7.7	7.6	7.2	5.3	3.5	1.5	0.2	0.0	0.0
JUNE 6	8.8	8.7	7.2	6.0	4.2	2.7	1.1	0.0	0.0	0.0
JUNE 7	10.2	10.0	7.8	5.9	4.1	2.6	1.1	0.0	0.0	0.0
JUNE 8	10.5	10.5	8.5	5.8	4.2	2.6	1.1	0.0	0.0	0.0
JUNE 11	8.5	8.6	8.2	3.7	2.5	1.2	0.2	0.0	0.0	0.0
JUNE 12	8.8	8.9	8.6	3.4	2.1	0.9	0.0	0.0	0.0	0.0
JUNE 13	9.2	9.3	7.2	2.9	1.5	0.4	0.0	0.0	0.0	0.0
JUNE 15	8.9	9.0	8.5	3.8	1.1	0.0	0.0	0.0	0.0	0.0
JUNE 18	7.2	7.3	7.3	7.0	0.1	0.0	0.0	0.0	0.0	0.0
JUNE 20	6.7	6.7	6.6	6.4	1.1	0.0	0.0	0.0	0.0	0.0
JUNE 21	8.0	8.0	7.5	4.9	0.3	0.0	0.0	0.0	0.0	0.0
JUNE 22	8.6	8.7	7.9	4.3	0.1	0.0	0.0	0.0	0.0	0.0
JUNE 25	7.5	7.5	7.5	7.2	4.8	0.0	0.0	0.0	0.0	0.0
JUNE 26	8.5	8.5	8.4	8.0	3.6	0.0	0.0	0.0	0.0	0.0
JUNE 27	8.0	7.8	7.3	6.4	2.3	0.0	0.0	0.0	0.0	0.0
JUNE 28	7.7	7.7	6.8	4.6	1.0	0.0	0.0	0.0	0.0	0.0
JUNE 29	8.1	8.0	7.6	4.0	0.6	0.0	0.0	0.0	0.0	0.0
JULY 2	7.9	8.0	7.8	4.9	0.2	0.0	0.0	0.0	0.0	0.0
JULY 3	8.9	8.9	8.7	5.7	0.0	0.0	0.0	0.0	0.0	0.0
JULY 5	9.0	9.0	8.5	3.3	0.0	0.0	0.0	0.0	0.0	0.0
JULY 6	8.0	8.1	7.7	3.2	0.0	0.0	0.0	0.0	0.0	0.0
JULY 9	8.1	8.1	8.0	5.5	0.0	0.0	0.0	0.0	0.0	0.0
JULY 10	7.3	7.3	7.3	6.7	0.0	0.0	0.0	0.0	0.0	0.0
JULY 11	8.1	8.1	7.7	5.5	0.0	0.0	0.0	0.0	0.0	0.0
JULY 12	8.6	8.7	8.1	5.4	0.0	0.0	0.0	0.0	0.0	0.0
JULY 13	8.2	8.3	8.2	4.9	0.0	0.0	0.0	0.0	0.0	0.0
JULY 16	6.6	6.7	6.6	6.0	0.0	0.0	0.0	0.0	0.0	0.0
JULY 17	7.6	7.7	7.3	3.3	0.9	0.7	0.2	0.0	0.0	0.0
JULY 18	7.9	7.9	5.8	0.5	1.1	0.4	0.1	0.0	0.0	0.0
JULY 19	6.4	6.4	6.2	3.2	0.5	0.3	0.0	0.0	0.0	0.0

TABLE VI (Continued)

DATE	DISSOLVED OXYGEN, MG/L									
	DEPTH, METERS									
	0	1	2	3	4	5	6	7	8	9
JULY 20	6.5	6.5	6.4	6.0	3.6	0.7	0.1	0.0	0.0	0.0
JULY 21	5.0	5.0	4.8	2.2	0.3	0.2	0.2	0.3	0.3	0.6
JULY 23	6.2	5.9	4.7	0.2	0.4	0.3	0.3	0.4	0.4	1.1
JULY 24	6.8	6.6	4.8	0.7	0.3	0.4	0.4	0.3	0.4	0.0
JULY 25	6.3	6.0	4.9	1.4	0.4	0.1	0.0	0.0	0.0	0.0
JULY 26	5.5	5.4	3.7	0.6	0.1	0.2	0.1	0.1	0.0	0.0
JULY 27	6.4	6.4	4.9	0.6	0.4	0.4	0.2	0.0	0.0	0.0
JULY 30	5.2	5.1	4.8	2.2	0.9	0.5	4.1	0.3	0.6	1.3
JULY 31	3.3	3.3	3.3	3.1	2.7	1.4	0.5	0.4	0.2	0.8
AUGUST 1	3.4	3.3	3.2	3.3	3.0	2.9	2.6	2.4	2.3	2.0
AUGUST 2	3.7	3.6	3.4	3.2	3.2	3.0	2.5	2.2	2.3	0.0
AUGUST 3	4.1	3.9	3.8	3.7	3.4	3.3	2.9	2.9	2.9	2.2
AUGUST 6	4.6	4.6	4.6	4.6	4.7	4.8	4.8	4.9	4.8	4.5
AUGUST 7	6.4	6.4	6.4	6.3	6.3	6.3	6.3	6.7	6.3	5.4
AUGUST 8	6.2	6.2	6.1	6.1	6.1	5.9	6.0	5.8	5.5	4.9
AUGUST 9	6.0	5.9	5.8	5.8	5.5	5.4	5.4	5.3	5.1	4.6
AUGUST 10	7.2	7.1	5.4	4.3	4.2	4.2	4.0	3.8	3.6	3.7
AUGUST 13	6.6	6.2	5.3	3.6	3.1	2.6	2.5	2.3	2.4	2.9
AUGUST 14	7.3	7.3	3.9	2.7	2.4	2.3	2.2	2.0	1.8	2.5
AUGUST 16	5.5	5.6	5.1	4.5	3.9	2.9	2.8	2.6	2.5	3.0
AUGUST 17	8.4	8.4	5.3	3.4	2.8	2.5	2.5	2.4	2.4	2.4
AUGUST 20	8.7	8.6	4.0	2.3	2.2	2.1	1.9	1.8	1.7	2.8
AUGUST 21	7.6	7.6	3.4	1.8	1.6	1.5	1.4	1.2	1.2	1.6
AUGUST 22	5.0	4.9	4.3	3.0	2.1	1.2	0.9	0.9	0.7	0.8
AUGUST 23	3.5	3.4	3.4	3.3	3.3	3.2	3.3	3.2	3.3	3.3
AUGUST 24	3.2	3.2	3.1	3.1	3.0	2.9	2.7	2.7	2.5	1.7
AUGUST 27	7.7	7.6	6.7	5.6	5.1	4.9	4.8	4.3	4.2	4.2
AUGUST 30	7.4	7.1	6.7	6.3	6.0	5.6	5.5	5.5	5.3	5.4
AUGUST 31	7.2	7.1	7.0	6.9	6.7	6.6	6.6	6.7	6.4	6.3
SEPT 5	6.2	6.2	6.2	6.2	6.2	6.2	6.1	6.2	6.2	6.3
SEPT 17	4.7	4.7	4.7	4.7	4.7	4.7	4.7	4.6	4.8	4.8
SEPT 22	6.8	6.7	6.6	6.1	5.0	3.9	3.5	3.1	3.0	2.5
SEPT 28	6.8	6.6	6.4	6.2	6.0	5.6	4.6	2.6	2.4	3.0
OCT 3	8.3	8.3	8.0	7.6	7.1	5.7	3.9	3.5	3.1	1.3
OCT 18	5.0	4.9	5.0	4.9	4.8	4.6	4.3	4.1	4.5	3.7

TABLE VII
 PROFILES OF ALKALINITY, pH, CO₂ AND CONDUCTANCE

Depth, Meters	Total Alkalinity as mg/1 CaCO ₃							
	5/22	6/4	6/11	6/15	6/20	6/22	6/25	6/29
1	111	108	112	109	112	110	113	113
3	105	107	108	110	112	108	114	115
5	106	111	116	114	117	113	117	118
7	108	113	115	117	133	117	123	123
9	125	126	130	136	136	132	150	157
	Carbonate Alkalinity as mg/1 CaCO ₃							
1	0	0	12	23	12	12	10	12
3	0	0	0	0	4	0	10	0
5	0	0	0	0	0	0	0	0
7	0	0	0	0	0	0	0	0
9	0	0	0	0	0	0	0	0
	pH							
1	8.1	7.4	8.8	8.94	8.62	8.87	8.55	8.55
3	7.6	7.35	7.7	7.66	8.47	8.16	8.47	7.85
5	7.45	7.4	7.4	7.48	7.46	7.47	7.43	7.37
7	7.4	7.4	7.4	7.55	7.52	7.55	7.50	7.43
9	7.7	7.35	7.6	7.71	7.63	7.65	7.54	7.47
	in CO ₂ mg/1							
1	1.6	8.3	0	0	0	0	0	0
3	5.0	9.0	4.1	4.5	0	1.3	0	3.0
5	7.3	8.5	8.3	7.3	7.7	7.4	8.3	9.5
7	8.3	8.5	8.7	6.2	7.2	6.3	7.5	8.8
9	4.7	11.0	6.3	5.1	6.3	5.6	8.3	10.0
	Specific Conductance micromhos/cm							
1				286	246	262	276	301
3				290	255	265	290	309
5				295	263	273	272	313
7				299	272	252	306	317
9				299	282	302	334	321

TABLE VII (Continued)

Depth, Meters	Total Alkalinity as mg/l CaCO ₃							
	7/2	7/6	7/9	7/13	7/16	7/19	7/24	7/27
1	111	110	109	112	107	106	107	106
3	115	112	110	118	109	106	113	110
5	122	119	122	127	124	117	115	111
7	130	127	133	140	132	122	114	111
9	158	154	170	175	155	123	121	114
	Carbonate Alkalinity as mg/l CaCO ₃							
1	12	12	25	19	12	12	6	4
3	0	0	23	0	0	12	0	0
5	0	0	0	0	0	0	0	0
7	0	0	0	0	0	0	0	0
9	0	0	0	0	0	0	0	0
	pH							
1	8.60	8.78	8.72	8.83	8.65	8.56	8.13	8.20
3	7.95	7.73	8.70	7.68	8.20	8.54	7.45	7.58
5	7.43	7.45	7.45	7.50	7.40	7.54	7.43	7.50
7	7.42	7.45	7.42	7.36	7.30	7.52	7.45	7.50
9	7.42	7.45	7.34	7.25	7.25	7.52	7.50	7.55
	in CO ₂ mg/l							
1	0	0	0	0	0	0	1.5	1.0
3	2.4	4.0	0	4.5	1.0	0	7.6	5.5
5	8.5	8.0	8.2	7.6	9.5	6.4	8.1	6.6
7	9.5	8.5	9.7	12.0	13.0	7.0	7.7	6.6
9	11.5	10.5	15.0	19.0	16.5	7.0	7.2	6.1
	Specific Conductance micromhos/cm							
1	312	283	275	261	258	287	275	261
3	312	291	271	268	246	275	283	271
5	321	295	291	283	290	295	283	271
7	292	291	299	299	299	295	283	275
9	374	318	334	339	322	299	287	279

TABLE VII (Continued)

Depth, Meters	Total Alkalinity as mg/l CaCO ₃							
	7/30	8/1	8/3	8/6	8/10	8/13	8/17	8/20
1	104	105	105	105	104	103	103	102
3	105	105	106	105	103	104	104	104
5	106	108	108	103	103	105	103	103
7	106	106	107	105	103	104	104	104
9	113	110	109	106	105	108	107	105
	Carbonate Alkalinity as mg/l CaCO ₃							
1	0	0	0	0	0	8	8	14
3	0	0	0	0	0	0	0	0
5	0	0	0	0	0	0	0	0
7	0	0	0	0	0	0	0	0
9	0	0	0	0	0	0	0	0
	pH							
1	8.00	7.73	7.75	7.95	8.25	8.53	8.64	8.77
3	7.57	7.74	7.80	7.97	7.85	7.94	8.05	7.74
5	7.52	7.65	7.75	7.95	7.83	7.76	7.78	7.70
7	7.47	7.70	7.70	7.90	7.80	7.66	7.73	7.70
9	7.50	7.70	7.62	7.82	7.65	7.60	7.71	7.62
	in CO ₂ mg/l							
1	2.0	3.5	3.5	2.2	1.0	0	0	0
3	5.4	3.5	3.2	2.1	2.9	2.2	1.7	3.5
5	6.0	4.6	3.7	2.2	2.9	3.4	3.2	3.9
7	6.8	4.0	4.0	2.5	3.1	4.3	3.7	3.9
9	6.8	4.1	5.0	3.0	4.5	5.1	4.0	4.8
	Specific Conductance micromhos/cm							
1	261	275	264	268	244	238	250	253
3	261	268	264	265	241	241	250	256
5	261	268	264	265	241	244	253	256
7	261	268	264	265	241	244	253	256
9	268	268	264	268	244	247	253	256

TABLE VII (Continued)

Depth, Meters	Total Alkalinity as mg/l CaCO ₃							
	8/22	8/24	8/27	8/31	9/5	9/7	9/11	9/14
1	103	101	102	103	105	104	105	99
3	102	102	103	105	105	104	104	98
5	102	101	103	105	104	105	103	99
7	101	103	103	105	103	104	103	96
9	102	106	107	105	106	104	104	91
	Carbonate Alkalinity as mg/l CaCO ₃							
1	0	0	0	0	0	0	12	0
3	0	0	0	0	0	0	0	0
5	0	0	0	0	0	0	0	0
7	0	0	0	0	0	0	0	0
9	0	0	0	0	0	0	0	0
	pH							
1	7.95	7.75	8.15	8.19	7.90	7.96	8.55	7.65
3	8.06	7.80	7.85	8.19	7.95	7.88	7.80	7.76
5	7.74	7.80	7.80	8.19	7.95	7.88	7.72	7.76
7	7.65	7.76	7.76	8.10	7.95	7.88	7.62	7.72
9	7.60	7.66	7.69	7.95	7.85	7.83	7.62	7.55
	in CO ₂ mg/l							
1	2.2	3.4	1.4	1.0	2.5	2.1	0	4.3
3	1.6	3.0	2.7	1.0	2.2	2.5	3.1	3.2
5	3.0	3.0	1.0	2.2	2.5	3.7	3.2	2.8
7	4.3	3.3	3.3	1.5	2.2	2.5	4.7	3.5
9	4.8	4.4	4.1	2.2	2.8	2.9	4.7	5.0
	Specific Conductance micromhos/cm							
1	256	254	255	230	242	234	264	206
3	252	247	252	228	239	234	257	210
5	252	247	252	228	237	234	254	208
7	256	247	249	225	237	234	254	206
9	263	254	252	228	237	234	254	187

TABLE VII (Continued)

Depth, Meters	Total Alkalinity as mg/l CaCO ₃				
	9/17	9/22	9/28	10/3	10/18
1	98	100	98	95	97
3	99	98	98	94	95
5	99	99	97	95	97
7	99	100	84	94	97
9	101	106	67	99	98
	Carbonate Alkalinity as mg/l CaCO ₃				
1	0	0	0	0	0
3	0	0	0	0	0
5	0	0	0	0	0
7	0	0	0	0	0
9	0	0	0	0	0
	pH				
1	7.73	7.90	8.04	8.02	7.70
3	7.80	7.95	7.95	8.03	7.78
5	7.82	7.83	7.92	7.80	7.75
7	7.82	7.73	7.44	7.58	7.70
9	7.82	7.65	7.40	7.52	7.67
	in CO ₂ mg/l				
1	3.5	2.4	1.7	1.7	3.8
3	2.0	2.1	2.1	1.7	
5	2.8	2.8	2.2	2.9	
7	2.8	3.5	5.9	4.7	3.8
9	2.8	4.5	5.1	5.7	
	Specific Conductance micromhos/cm				
1	232	249	230	228	221
3	232	246	222	223	219
5	232	246	222	218	217
7	232	244	194	218	219
9	232	244	149	225	219

TABLE VIII
 PROFILES OF BOD₅

Date	BOD ₅ mg/l				
	Depth, Meters				
	1	3	5	7	9
5/30	2.4	1.6	1.4	0.8	6.2
6/ 6	3.0	1.0	0.6	1.8	8.0
6/14	2.4	1.6	1.0	2.4	10.0
6/20	1.7	1.8	2.6	3.8	7.5
6/27	1.9	1.9	2.3	3.4	6.1
7/ 5	2.6	3.2	3.6	5.4	18.0
7/12	-	3.4	2.2	6.9	15.5
7/18	3.2	2.6	4.8	6.6	8.5
7/25	0.8	1.8	1.8	1.8	4.4
8/ 1	1.5	2.6	2.8	2.4	2.8
8/ 8	2.3	1.6	1.8	1.0	1.4
8/14	2.6	2.8	0.6	0.4	0.6
8/22	2.5	3.4	2.4	3.0	0.2
8/31	1.8	2.2	2.6	2.4	3.0
9/ 7	1.4	2.6	3.0	2.2	3.0
9/28	2.4	2.0	1.8	5.4	3.6

TABLE IX
 TURBIDITY

Date	Jackson Turbidity Units	Date	Jackson Turbidity Units
June 25	19	August 2	15
June 26	19	August 3	15
June 27	14	August 6	21
June 28	15	August 7	21
June 29	14	August 8	17
July 2	13	August 9	19
July 3	13	August 10	19
July 5	11	August 11	15
July 6	10	August 12	13
July 9	11	August 13	15
July 10	13	August 14	14
July 11	13	August 15	15
July 12	14	August 16	17
July 13	14	August 17	14
July 15	17	August 20	14
July 16	17	August 21	11
July 17	14	August 22	11
July 18	13	August 23	14
July 19	12	August 24	11
July 20	20	August 27	13
July 22	12	August 30	14
July 23	11	August 31	17
July 24	12	September 5	15
July 25	10	September 7	19
July 26	11	September 14	62
July 27	10	September 17	30
July 30	12	September 22	25
July 31	13	September 28	29
August 1	14	October 3	24
		October 18	17

TABLE X
PUMP DATA

Pulley No.	RPM	m^3Q /sec	P Watts
No Diffuser			
16	32	0.603	201
18	37	0.666	261
20	40	0.716	343
24	48	0.852	522
With Diffuser			
16	32	0.702	157
18	37	0.773	194
20	40	0.852	239
24	48	0.991	373

TABLE XI
PLANKTON COUNTS

Organism	6/ 8/73 Composite	6/12/73 Composite	6/15/73 Composite	6/21/73 Composite	6/27/73 Composite
CHLOROPHYTA					
<u>Ankistrodesmus</u>	21,343	--	--	--	--
<u>Arthrodesmus</u>	3,049	--	--	--	--
<u>Closterium</u>	6,098	--	--	--	--
<u>Coelastrum</u>	--	6,098	--	9,147	6,098
<u>Cosmarium</u>	--	--	--	--	--
<u>Pediastrum</u>	54,882	36,588	--	15,245	24,392
<u>Scenedesmus</u>	--	--	42,686	--	--
<u>Spirogyra</u>	--	--	--	--	--
<u>Staurastrum</u>	--	--	--	--	--
<u>Tetraedon</u>	--	--	--	--	--
CYANOPHYTA					
<u>Anabaena</u>	30,490	91,470	54,882	36,588	24,392
<u>Dactylococcopsis</u>	--	--	--	--	--
<u>Merismopedia</u>	--	--	--	--	--
<u>Microcystis</u>	70,127	18,294	3,049	12,196	3,049
<u>Spirulina</u>	--	--	3,049	--	--
EUGLENOPHYTA					
<u>Euglena</u>	131,107	109,764	134,156	100,617	36,588
<u>Phacus</u>	3,049	--	--	--	--
PYRRHOPHYTA					
<u>Ceratium</u>	3,049	3,049	3,049	3,049	9,147
CHRYSOPHYTA					
<u>Cyclotella</u>	18,294	12,196	3,049	30,490	9,147
<u>Cymbella</u>	--	--	--	--	3,049
<u>Gomphonema</u>	--	--	--	--	--
<u>Melosira</u>	12,196	6,098	15,245	21,343	39,637
<u>Pinnularia</u>	--	--	--	--	--
<u>Surirella</u>	--	--	--	--	--
<u>Synedra</u>	--	--	--	--	--
<u>Tribonema</u>	--	--	--	--	3,049
TOTAL	353,684	283,557	259,165	228,675	158,548

TABLE XI (Continued)

Organism	6/29/73 Composite	7/ 3/73 Composite	7/ 6/73 Composite	7/ 9/73 Composite	7/12/73 Composite
CHLOROPHYTA					
<u>Ankistrodesmus</u>	3,049	--	--	--	--
<u>Arthrodesmus</u>	--	--	6,098	3,049	--
<u>Closterium</u>	--	--	--	--	--
<u>Coelastrum</u>	--	--	3,049	--	--
<u>Cosmarium</u>	--	--	--	--	--
<u>Pediastrum</u>	6,098	6,098	15,245	6,098	3,049
<u>Scenedesmus</u>	--	--	12,196	--	--
<u>Spirogyra</u>	--	--	--	--	--
<u>Staurastrum</u>	--	--	--	--	--
<u>Tetraedon</u>	--	--	--	--	--
CYANOPHYTA					
<u>Anabaena</u>	152,450	54,882	33,539	60,980	173,793
<u>Dactylococcopsis</u>	--	--	--	--	--
<u>Merismopedia</u>	--	--	--	--	--
<u>Microcystis</u>	6,098	--	--	3,049	3,049
<u>Spirulina</u>	--	--	--	--	--
EUGLENOPHYTA					
<u>Euglena</u>	18,294	15,245	9,147	39,637	18,294
<u>Phacus</u>	--	--	--	--	--
PYRRHOPHYTA					
<u>Ceratium</u>	3,049	6,098	--	3,049	--
CHRYSTOPHYTA					
<u>Cyclotella</u>	6,098	6,098	3,049	15,245	3,049
<u>Cymbella</u>	--	--	--	--	--
<u>Gomphonema</u>	--	--	--	--	--
<u>Melosira</u>	12,196	9,147	24,392	27,441	9,147
<u>Pinnularia</u>	--	--	--	--	--
<u>Surirella</u>	--	--	--	--	--
<u>Synedra</u>	--	--	9,147	3,049	3,049
<u>Tribonema</u>	--	--	--	9,147	--
TOTAL	207,332	97,568	115,862	170,744	213,430

TABLE XI (Continued)

Organism	7/16/73 Composite	7/19,73 Composite	7/23/73 Composite	7/27/73 Composite	7/30/73 Composite
CHLOROPHYTA					
<u>Ankistrodesmus</u>	--	--	--	--	--
<u>Arthrodesmus</u>	--	--	--	--	--
<u>Closterium</u>	--	--	--	--	--
<u>Coelastrum</u>	--	3,049	--	6,098	3,049
<u>Cosmarium</u>	--	--	6,098	9,147	--
<u>Pediastrum</u>	9,147	9,147	12,156	9,147	9,147
<u>Scenedesmus</u>	--	3,049	3,049	9,147	--
<u>Spirogyra</u>	--	--	--	--	--
<u>Staurastrum</u>	--	--	--	--	--
<u>Tetraedon</u>	--	--	--	--	--
CYANOPHYTA					
<u>Anabaena</u>	286,606	225,862	6,098	9,147	3,049
<u>Dactylococcopsis</u>	15,245	544,544	79,274	12,196	12,196
<u>Merismopedia</u>	--	--	--	3,049	--
<u>Microcystis</u>	--	--	3,049	3,049	6,098
<u>Spirulina</u>	--	--	--	--	--
EUGLENOPHYTA					
<u>Euglena</u>	64,029	43,316	15,245	128,058	304,900
<u>Phacus</u>	--	--	--	--	--
PYRRHOPHYTA					
<u>Ceratium</u>	--	3,049	--	15,245	3,049
CHRYSOPHYTA					
<u>Cyclotella</u>	6,098	3,049	3,049	6,098	27,441
<u>Cymbella</u>	--	--	--	6,098	--
<u>Gomphonema</u>	--	--	--	--	--
<u>Melosira</u>	6,098	15,245	21,343	9,147	3,049
<u>Pinnularia</u>	--	--	--	--	--
<u>Surirella</u>	--	--	--	--	--
<u>Synedra</u>	6,098	9,147	3,049	3,049	6,098
<u>Tribonema</u>	--	--	--	--	--
TOTAL	393,321	859,457	152,450	228,675	378,076

TABLE XI (Continued)

Organism	8/ 6/73 Composite	8/10/73 Composite	8/10/73 1 meter	8/10/73 2 meters	8/10/73 3 meters
CHLOROPHYTA					
<u>Ankistrodesmus</u>	3,049	--	--	--	--
<u>Arthrodesmus</u>	--	--	--	--	--
<u>Closterium</u>	--	--	--	--	--
<u>Coelastrum</u>	--	6,098	12,196	6,098	6,098
<u>Cosmarium</u>	--	--	--	--	3,049
<u>Pediastrum</u>	6,098	6,098	18,296	21,343	15,245
<u>Scenedesmus</u>	--	--	--	--	--
<u>Spirogyra</u>	--	--	--	--	--
<u>Staurastrum</u>	--	--	--	--	--
<u>Tetraedon</u>	--	--	--	--	--
CYANOPHYTA					
<u>Anabaena</u>	--	--	--	--	--
<u>Dactylococcopsis</u>	9,147	21,343	9,147	15,245	9,147
<u>Merismopedia</u>	--	--	--	--	--
<u>Microcystis</u>	--	--	--	--	--
<u>Spirulina</u>	--	--	--	--	--
EUGLENOPHYTA					
<u>Euglena</u>	3,049	12,196	21,343	3,049	3,049
<u>Phacus</u>	--	--	--	--	--
PYRRHOPHYTA					
<u>Ceratium</u>	3,049	3,049	--	3,049	--
CHRYSOPHYTA					
<u>Cyclotella</u>	94,519	454,301	271,361	307,949	125,009
<u>Cymbella</u>	--	6,098	--	--	--
<u>Gomphonema</u>	--	--	--	--	--
<u>Melosira</u>	18,294	30,490	33,539	30,490	33,539
<u>Pinnularia</u>	--	--	3,049	--	3,049
<u>Surirella</u>	--	--	--	--	--
<u>Synedra</u>	--	3,049	3,049	--	3,049
<u>Tribonema</u>	--	15,245	3,049	--	3,049
TOTAL	137,205	557,967	375,029	387,223	204,283

TABLE XI (Continued)

Organism	8/13/73 Composite	8/13/73 1 meter	8/13/73 2 meters	8/13/73 3 meters	8/16/73 Composite
CHLOROPHYTA					
<u>Ankistrodesmus</u>	--	--	--	--	--
<u>Arthrodesmus</u>	--	--	--	--	--
<u>Closterium</u>	--	--	--	--	--
<u>Coelastrum</u>	--	21,343	--	3,049	9,147
<u>Cosmarium</u>	--	--	--	--	--
<u>Pediastrum</u>	33,539	6,098	9,147	12,196	6,098
<u>Scenedesmus</u>	--	--	--	--	--
<u>Spirogyra</u>	--	--	--	--	--
<u>Staurastrum</u>	--	--	--	--	--
<u>Tetraedon</u>	--	--	--	--	--
CYANOPHYTA					
<u>Anabaena</u>	--	--	--	--	15,245
<u>Dactylococcopsis</u>	42,686	33,539	33,539	350,635	231,724
<u>Merismopedia</u>	--	--	--	--	--
<u>Microcystis</u>	--	--	--	--	--
<u>Spirulina</u>	--	--	--	--	--
EUGLENOPHYTA					
<u>Euglena</u>	6,098	3,049	6,098	--	9,147
<u>Phacus</u>	--	--	--	--	--
PYRRHOPHYTA					
<u>Ceratium</u>	3,049	--	--	--	--
CHRYSOPHYTA					
<u>Cyclotella</u>	801,887	798,838	737,858	561,016	341,488
<u>Cymbella</u>	--	--	--	--	--
<u>Gomphonema</u>	--	--	--	--	--
<u>Melosira</u>	18,294	9,147	12,196	18,294	6,098
<u>Pinnularia</u>	3,049	--	--	--	--
<u>Surirella</u>	--	--	--	--	--
<u>Synedra</u>	3,049	--	--	--	--
<u>Tribonema</u>	--	--	--	--	--
TOTAL	911,651	872,014	798,838	945,190	618,947

TABLE XI (Continued)

Organism	8/20/73 Composite	8/20/73 Surface	8/20/73 1 meter	8/20/73 2 meters	8/20/73 3 meters
CHLOROPHYTA					
<u>Ankistrodesmus</u>	3,049	--	--	--	--
<u>Arthrodesmus</u>	--	6,098	--	--	--
<u>Closterium</u>	--	--	--	--	--
<u>Coelastrum</u>	27,441	--	--	6,098	--
<u>Cosmarium</u>	--	--	--	3,049	--
<u>Pediastrum</u>	9,147	21,343	15,245	15,245	6,098
<u>Scenedesmus</u>	--	6,098	3,049	--	--
<u>Spirogyra</u>	--	3,049	--	6,098	3,049
<u>Staurastrum</u>	3,049	--	--	--	--
<u>Tetraedon</u>	--	--	--	--	--
CYANOPHYTA					
<u>Anabaena</u>	12,196	6,098	36,588	12,196	3,049
<u>Dactylococcopsis</u>	131,107	36,588	112,813	155,499	1,143,375
<u>Merismopedia</u>	--	--	--	--	--
<u>Microcystis</u>	--	--	--	--	--
<u>Spirulina</u>	--	--	--	--	--
EUGLENOPHYTA					
<u>Euglena</u>	6,098	--	18,294	15,245	3,049
<u>Phacus</u>	--	--	--	--	--
PYRRHOPHYTA					
<u>Ceratium</u>	--	--	3,049	--	--
CHRYSOPHYTA					
<u>Cyclotella</u>	51,833	48,784	57,931	57,931	27,441
<u>Cymbella</u>	--	--	--	--	--
<u>Gomphonema</u>	--	--	--	--	--
<u>Melosira</u>	6,098	6,098	6,098	12,196	15,245
<u>Pinnularia</u>	6,098	--	--	3,049	--
<u>Surirella</u>	--	--	3,049	--	--
<u>Synedra</u>	--	--	--	--	--
<u>Tribonema</u>	--	--	--	--	--
TOTAL	256,116	134,156	256,116	283,606	1,201,306

TABLE XI (Continued)

Organism	8/22/73 Surface	8/22/73 1 meter	8/22/73 2 meters	8/22/73 3 meters	8/24/73 Composite
CHLOROPHYTA					
<u>Ankistrodesmus</u>	--	--	9,147	--	--
<u>Arthrodesmus</u>	--	--	--	--	3,049
<u>Closterium</u>	--	--	--	--	--
<u>Coelastrum</u>	3,049	3,049	9,147	3,049	--
<u>Cosmarium</u>	3,049	--	--	--	--
<u>Pediastrum</u>	9,147	3,049	6,098	9,147	9,147
<u>Scenedesmus</u>	--	--	--	--	--
<u>Spirogyra</u>	--	--	--	--	--
<u>Staurastrum</u>	--	6,098	--	--	3,049
<u>Tetraedon</u>	--	--	3,049	--	--
CYANOPHYTA					
<u>Anabaena</u>	--	9,147	3,049	9,147	3,049
<u>Dactylococcopsis</u>	731,760	765,299	847,622	884,210	887,259
<u>Merismopedia</u>	--	--	--	--	--
<u>Microcystis</u>	--	--	--	--	--
<u>Spirulina</u>	--	--	--	--	--
EUGLENOPHYTA					
<u>Euglena</u>	18,294	36,588	54,882	54,882	36,588
<u>Phacus</u>	--	--	--	--	--
PYRRHOPHYTA					
<u>Ceratium</u>	3,049	--	--	--	--
CHRYSOPHYTA					
<u>Cyclotella</u>	103,666	73,176	109,764	91,470	128,058
<u>Cymbella</u>	--	--	--	--	--
<u>Gomphonema</u>	--	--	--	--	--
<u>Melosira</u>	12,196	12,196	6,098	18,294	12,196
<u>Pinnularia</u>	--	--	--	--	--
<u>Surirella</u>	--	--	--	--	--
<u>Synedra</u>	--	--	--	3,049	--
<u>Tribonema</u>	--	--	--	--	--
TOTAL	884,210	908,602	1,051,905	1,073,248	1,082,395

TABLE XI (Continued)

Organism	8/27/73 Composite	8/31/73 Composite	9/ 5/73 Composite	9/ 7/73 Composite	9/11/73 Composite
CHLOROPHYTA					
<u>Ankistrodesmus</u>	6,098	6,098	--	--	3,049
<u>Arthrodesmus</u>	--	--	--	--	--
<u>Closterium</u>	--	--	--	--	--
<u>Coelastrum</u>	3,049	12,196	3,049	--	39,637
<u>Cosmarium</u>	--	--	--	--	--
<u>Pediastrum</u>	30,490	15,245	12,196	6,098	27,441
<u>Scenedesmus</u>	--	3,049	--	--	--
<u>Spirogyra</u>	--	--	--	--	--
<u>Staurastrum</u>	3,049	--	--	--	--
<u>Tetraedon</u>	--	--	--	--	--
CYANOPHYTA					
<u>Anabaena</u>	--	--	--	--	18,294
<u>Dactylococcopsis</u>	429,909	628,094	152,450	283,557	387,223
<u>Merismopedia</u>	3,049	3,049	--	--	--
<u>Microcystis</u>	--	--	--	--	--
<u>Spirulina</u>	--	--	--	--	--
EUGLENOPHYTA					
<u>Euglena</u>	125,009	115,862	33,539	21,343	155,499
<u>Phacus</u>	--	--	--	--	--
PYRRHOPHYTA					
<u>Ceratium</u>	--	--	3,049	--	--
CHRYSOPHYTA					
<u>Cyclotella</u>	320,145	429,909	234,773	134,156	192,087
<u>Cymbella</u>	3,049	--	--	--	--
<u>Gomphonema</u>	--	--	3,049	--	--
<u>Melosira</u>	60,980	88,421	97,568	128,058	182,940
<u>Pinnularia</u>	3,049	--	--	--	--
<u>Surirella</u>	--	--	--	--	--
<u>Synedra</u>	--	3,049	--	--	--
<u>Tribonema</u>	--	--	--	--	--
TOTAL	987,876	1,308,021	539,673	573,212	1,006,170

TABLE XI (Continued)

Organism	9/14/73 Composite	9/17/73 Composite	9/22/73 Composite	9/28/73 Composite	10/ 3/73 Composite
CHLOROPHYTA					
<u>Ankistrodesmus</u>	3,049	--	--	--	--
<u>Arthrodesmus</u>	--	--	--	--	--
<u>Closterium</u>	--	--	--	--	--
<u>Coelastrum</u>	3,049	6,098	3,049	3,049	--
<u>Cosmarium</u>	--	--	--	--	--
<u>Pediastrum</u>	--	6,098	6,098	--	3,049
<u>Scenedesmus</u>	--	6,098	--	3,049	3,049
<u>Spirogyra</u>	--	--	--	--	--
<u>Staurastrum</u>	--	--	--	3,049	--
<u>Tetraedon</u>	--	--	--	--	--
CYANOPHYTA					
<u>Anabaena</u>	--	3,049	45,735	88,421	42,686
<u>Dactylococcopsis</u>	338,439	1,131,179	478,693	143,303	286,606
<u>Merismopedia</u>	--	--	--	--	--
<u>Microcystis</u>	--	--	--	--	--
<u>Spirulina</u>	--	--	--	--	--
EUGLENOPHYTA					
<u>Euglena</u>	21,343	30,490	24,392	60,980	125,009
<u>Phacus</u>	--	--	--	--	--
PYRRHOPHYTA					
<u>Ceratium</u>	3,049	3,049	--	3,049	--
CHRYSOPHYTA					
<u>Cyclotella</u>	67,078	27,441	21,343	15,245	12,196
<u>Cymbella</u>	3,049	--	--	6,098	6,098
<u>Gomphonema</u>	--	--	--	--	--
<u>Melosira</u>	109,764	145,862	100,617	33,529	33,529
<u>Pinnularia</u>	--	--	--	--	--
<u>Surirella</u>	--	--	--	--	--
<u>Synedra</u>	6,098	--	3,049	--	--
<u>Tribonema</u>	--	--	--	--	--
TOTAL	554,918	1,329,364	682,976	359,782	512,232

VITA

James Matthew Steichen

Candidate for the Degree of

Doctor of Philosophy

Thesis: THE EFFECT OF LAKE DESTRATIFICATION ON WATER QUALITY PARAMETERS

Major Field: Agricultural Engineering

Biographical:

Personal Data: Born in Stillwater, Oklahoma, November 14, 1947,
the son of Mr. and Mrs. John H. Steichen

Education: Graduated from Perry High School, Perry, Oklahoma, in
May, 1965; received Bachelor of Science degree in Agricultural
Engineering from Oklahoma State University in January, 1970;
enrolled in Master of Engineering program at Texas A&M
University in 1971; completed requirements for the Doctor of
Philosophy degree at Oklahoma State University in July, 1974.

Professional Experience: Summer Engineering Trainee, Cargill Inc.,
Wichita, Kansas, 1969; Maintainability Engineering Intern,
Army Materiel Command, Texarkana, Texas, 1970-1971; Graduate
Research Assistant, Oklahoma State University, 1971-1974.

Professional and Honorary Societies: Engineer-in-training, Student
Member; American Society of Agricultural Engineers, Phi Kappa
Phi; Sigma Tau; Alpha Zeta; Omicron Delta Kappa.