

THE ZINC SMELTING INDUSTRY IN OKLAHOMA

By

ROLAND DELOY MOWER

Bachelor of Science

University of Utah

Salt Lake City, Utah

1955

Submitted to the Faculty of the Graduate School of  
the Oklahoma State University  
in Partial Fulfillment of the Requirements  
for the Degree of  
MASTER OF SCIENCE  
August, 1959

NOV 18 1959

THE ZINC SMELTING INDUSTRY IN OKLAHOMA

Thesis Approved:

Ralph E. Birchard  
Thesis Adviser

Edward R. Keso

John M. ...  
Dean of the Graduate School

430809

## PREFACE

One of the most important aspects of the tremendous development and growth of American industry is an increased awareness of the basic metals, their products and their uses. Steel, aluminum and copper are particularly well known because of the publicity they receive and because their presence is easily recognized in a wide range of consumer products. On the other hand zinc, which ranks fourth among other metals with respect to production, is relatively unknown. Because zinc is generally used in conjunction with other metals its identity is often hidden and the average person, unaware of zinc's wide application and uses in industry, fails to recognize its significance.

In this study of Oklahoma's zinc smelting industry I have attempted to acquaint the average Oklahoman with zinc, its sources, products and consumers. The zinc industry as a whole is discussed, but special emphasis is given to that part of the industry located in Oklahoma.

Information contained in this thesis was obtained from various published materials found in several libraries, through personal interviews with officials at each of Oklahoma's zinc smelters and by actually observing the varied processes employed at these plants.

I wish to express my appreciation to Dr. Ralph E. Birchard, Chairman of the Advisory Committee, for his assistance in the completion of this study and for his criticism and encouragement during its preparation, and to Dr. Edward E. Keso, Advisory Committee member, for his counsel and interest in all matters pertaining to my work.

I also wish to express my profound gratitude to all officials at Oklahoma's smelters who contributed both time and information without which this study could not have been completed.

Finally, I wish to thank my wife for her untiring moral support and assistance.

R. D. M.

## TABLE OF CONTENTS

Chapter	Page
I. DEVELOPMENT OF THE ZINC INDUSTRY. . . . .	1
Early History. . . . .	1
Zinc Minerals. . . . .	2
Zinc Mining in the United States . . . . .	2
Zinc Reserves. . . . .	6
Zinc Smelting. . . . .	8
II. METALLURGY OF ZINC. . . . .	18
Recovery of Primary Zinc . . . . .	18
Recovery of Secondary Zinc Dust. . . . .	28
III. ZINC PRODUCTS, FOREIGN TRADE AND NATIONAL POLICY. . . . .	30
Zinc Slab. . . . .	30
Other Associated Products. . . . .	37
Foreign Trade. . . . .	41
National Policy on Zinc. . . . .	45
IV. ECONOMICS OF ZINC SMELTING. . . . .	50
Locative Factors . . . . .	50
Economic Character . . . . .	53
Zinc Smelting Costs. . . . .	54
V. OKLAHOMA'S ZINC SMELTING PLANTS . . . . .	65
The Bartlesville Zinc Smelter. . . . .	68
The Blackwell Zinc Smelter . . . . .	74
The Henryetta Zinc Smelter . . . . .	78
The Sand Springs Secondary Smelter . . . . .	83
VI. SUMMARY AND CONCLUSION. . . . .	90
SELECTED BIBLIOGRAPHY . . . . .	98

## LIST OF TABLES

Table	Page
I. Districts or Regions Containing Zinc Reserves in 1950. . .	10
II. Estimated World Zinc Reserves January, 1957 (Measured and Indicated) . . . . .	11
III. Primary Zinc Distillers Operating in 1957. . . . .	16
IV. Secondary Zinc Distillers, 1957. . . . .	17
V. Standard Specifications for Zinc Slab (Maximum Impurities Allowed) . . . . .	32
VI. Zinc Slab Production by Grade, 1957. . . . .	33
VII. Zinc Slab Consumption by Industries. . . . .	37
VIII. Average Price of Zinc Dust and Prime Western Zinc Slab (1946 to 1957). . . . .	41
IX. Import Quota Per Three-Month Period for Zinc Blocks, Pigs, or Slabs, and Zinc Dust. . . . .	48
X. Import Quota Per Three-Month Period for Zinc Bearing Ores of All Kinds. . . . .	48
XI. Raw Materials Required to Produce One Ton of Zinc Slab . .	56
XII. Cost of Transporting Zinc from Foreign Countries to United States Markets. . . . .	63
XIII. Average Costs of Transportation, Insurance and Handling of Zinc Concentrates from Sources to Domestic Zinc Smelters, 1952. . . . .	64
XIV. Average costs of Transportation, Insurance and Handling of Zinc Slab from Domestic Smelters to Consuming Areas per Short Ton, 1952. . . . .	64

## LIST OF ILLUSTRATIONS

Figure	Page
1. Zinc Mine Production in United States, 1907-1957 . . . . .	7
2. Zinc Reserves in the United States, 1950 . . . . .	9
3. Location of Zinc Smelting and Refining Plants in the United States, 1957 . . . . .	15
4. Basic Processes of Primary Zinc Slab Production . . . . .	19
5. Horizontal Retort Zinc Smelter Flow Sheet . . . . .	21
6. Typical Horizontal Retort Distillation Furnace . . . . .	25
7. The Flow of Zinc from Mine to Market . . . . .	31
8. Average Price of Prime Western at East St. Louis, 1900-1957 . . . . .	34
9. Zinc Slab Consumption by States, 1956 . . . . .	36
10. Domestic Zinc Dust Production, 1925-1958 . . . . .	40
11. Domestic Zinc Smelter Production by Source, 1907-1957 . . . . .	43
12. Source of Imported Zinc, 1957 . . . . .	44
13. Zinc Smelting and Refining Expenses . . . . .	55
14. Aerial View of American Metal Climax, Inc., Primary Zinc Smelter at Blackwell, Oklahoma . . . . .	66
15. Primary Zinc Slab Production in Oklahoma, 1907-1957 . . . . .	67
16. Location of Zinc Mines and Smelters . . . . .	69

## CHAPTER I

### DEVELOPMENT OF THE ZINC INDUSTRY

#### Early History

The art of producing zinc as a separate metal may have been known to the inhabitants of the Isle of Rhodes prior to 500 B.C. as evidenced by zinc-filled bracelets discovered in the prehistoric ruins of Camirus.<sup>1</sup> Some experts feel there was no general knowledge of zinc during this early period, and they question both the composition and the origin of the evidence.<sup>2</sup>

Later, around 200 B.C., the Greeks and Romans began melting copper and zinc materials together to obtain brass. Brass has been known since that time, but if zinc was known earlier its identity was lost and it did not reappear in Europe until the sixteenth century when Paracelsus showed zinc to be a separate metal.<sup>3</sup>

In 1597 Libavius described "a kind of tin" he had obtained from India, but he did not know its connection with the common zinc ore calcine. When zinc smelting began about 1830 in England, the solid form of zinc produced was called "spelter," a name from German "spialter" that

---

<sup>1</sup>Oliver Davies, Roman Mines in Europe (Oxford, 1935), pp. 60-61.

<sup>2</sup>R. J. Forbes, Metallurgy in Antiquity (Leiden, 1950), pp. 273-276.

<sup>3</sup>Ibid., p. 276.



persisted until recent times.<sup>4</sup> Today zinc is normally referred to as "zinc slab" rather than by the older term.

### Zinc Minerals

Lead and zinc minerals are often closely associated in geologic formations and most always occur together, but in some areas one is found without the other. Zinc minerals also occur in complex ores associated with iron, gold, silver and other minerals. The most common zinc mineral is sphalerite or zinc blend ( $ZnS$ ), and its oxidation products smithsonite ( $ZnCO_3$ ) and hemimorphite [ $(ZnOH)_2SiO_3$ ]. Several others, zincite ( $ZnO$ ), willemite ( $Zn_2SiO_4$ ), and franklinite [ $(FeZnMn)O_3$ ] occur in a unique and very important zinc deposit near Franklin, New Jersey.<sup>5</sup>

### Zinc Mining in the United States

In 1835 the Government Arsenal at Washington, D. C., smelted a small quantity of zinc ore from the Franklin, New Jersey, area. The recovered zinc metal was alloyed with copper to produce brass for standard weights and measures.<sup>6</sup> Commercial exploitation of the Franklin furnace ores did not begin until about 1848 when a small smelter was constructed by the Sussex Zinc and Copper Mining and Manufacturing Company at Newark, New Jersey.<sup>7</sup>

---

<sup>4</sup>Ibid., pp. 272-273.

<sup>5</sup>Mineral Facts and Problems, Bureau of Mines, Bulletin 556 (Washington, 1956), p. 989.

<sup>6</sup>Alan M. Bateman, Economic Mineral Deposits (New York, 1942), pp. 525-526.

<sup>7</sup>W. R. Ingalls, Lead and Zinc in the United States (New York, 1908), p. 280.

Zinc mines had been developed and were operating in the upper Mississippi valley and southeast Missouri by 1860. Zinc mining in southwest Missouri began in 1871 near Granby, but operations were limited until the railroad was completed into the area the following year. Mines were operating at Webb City and Cartersville, Missouri, and Galena, Kansas, by 1876. Mine production continued to increase in the Joplin area as new ore deposits were discovered and facilities at working mines were expanded. By 1880 Joplin had replaced Granby as the leading zinc ore producer in the area.<sup>8</sup>

During the 1880's and 1890's numerous mines were developed throughout the country to meet the increasing demand for zinc. Technological developments permitted greater utilization of ores in Wisconsin, Virginia, New York and Tennessee, but the complex western ores were of little commercial importance until after 1925.<sup>9</sup>

Oklahoma contributed very little prior to the discovery of rich ore deposits near Picher in 1914. Although this area later became the greatest of all zinc producers, its importance was not immediately apparent. A serious water problem hampered operations but once the potential of the area was realized, production increased at an unbelievable rate.<sup>10</sup> In 1912 Oklahoma produced only 5,769 tons, but by 1918 Oklahoma had become the leading zinc mining state. Mining operations

---

<sup>8</sup>"The Story of the Tri-State Zinc and Lead Mining District," Souvenir Booklet (Joplin, 1931), p. 5.

<sup>9</sup>Ingalls, Lead and Zinc in the United States, p. 294.

<sup>10</sup>John S. Brown, "A Graphic Statistical History of the Joplin or Tri-state Lead-Zinc District," Mining Engineering, III (1951), p. 786.

continued to expand throughout the Picher-Commerce area and in 1925 an all-time high of 283,371 tons were mined.<sup>11</sup>

Zinc mining in the United States ranges from the small one man operation to the extensive operations of large corporations with several mining properties. Many of the large mines are owned and operated by vertically integrated companies that extend their control forward from the mine to the smelter and in some instances from mine to market. Many mining companies are also integrated horizontally to include other metals such as lead, iron or copper from both domestic and foreign sources.

The number of mines in operation throughout the country depends to a great extent on zinc prices. "The total costs of operation, including materials, labor, and power needed in maintaining the mine and plant, as well as all administrative charges and expenses, must be borne by the sale value of the metal produced."<sup>12</sup> In 1952 there were 600 mines operating in the United States, but by the end of 1953 approximately 200 of these mines had closed because of a sharp decline in zinc prices.<sup>13</sup> Since 1953 production cutbacks and mine closures have taken place in several major mining areas.<sup>14</sup>

Domestic mine production was limited to 19 states in 1957. These states are usually divided for convenience into three geographic regions: the Western States, the West Central States, and the States East of the Mississippi.<sup>15</sup>

---

<sup>11</sup>Mineral Resources of the United States 1925, Part I, United States Geological Survey (Washington, 1928), p. 336.

<sup>12</sup>T. J. Hoover, The Economics of Mining (3d. ed., Stanford, 1948), p. 24.

<sup>13</sup>Mineral Facts and Problems, p. 982.

<sup>14</sup>Lead and Zinc, United States Tariff Commission, Report to the President on Escape-Clause Investigation, No. 65 (Washington, 1958), pp. 52-53.

<sup>15</sup>Minerals Yearbook 1957, Part I, Bureau of Mines (Washington, 1958), p. 1286.

The Western States region produced 55 percent of the zinc mined in 1957.<sup>16</sup> The principal mining districts in the west are the Summit Valley (Butte) district, Montana; the Couer d' Alene district, Idaho; the Warren (Bisbee) and Big Bug districts, Arizona; the Central and Magdalena districts, New Mexico; West Mountain (Bingham), Tintic and Park City districts, Utah; Pioche district, Nevada; Red Cliff and Ten Mile districts, Colorado; and the Pend Oreille and Metoline districts, Washington.<sup>17</sup>

The West Central States region includes all of Arkansas, Kansas, Missouri and Oklahoma. The principal producer in this region is the Tri-State district which is defined as an area about 100 miles long and 30 miles wide located in the adjacent areas of Missouri, Oklahoma and Kansas. This district was previously known as the Joplin district.<sup>18</sup> Mine production in the Tri-State district has declined since World War II and in 1957 the former "Giant" mined less than six percent of the nation's zinc. Although the known rich ore reserves in this area have been depleted, mines in Oklahoma and Kansas are still important producers; however, they probably will never again claim the importance once enjoyed by the Tri-State district.<sup>19</sup>

Production in the States East of the Mississippi reached 202,931 tons, 38 percent of the total domestic production in 1957.<sup>20</sup> New York replaced Montana as the leading zinc mining state and Tennessee became the second

---

<sup>16</sup>Ibid., pp. 1286-1288.

<sup>17</sup>Mineral Facts and Problems, p. 982.

<sup>18</sup>H. W. Kitson, "The Mining Districts of Joplin and Southeast Missouri," Mining Practices (New York, 1919), p. 7.

<sup>19</sup>Minerals Yearbook 1957, p. 1288.

<sup>20</sup>Ibid., pp. 1288-1289.

largest producer. The major districts in the east include: St. Lawrence County district, New York; the Mascot area, Tennessee; Sussex County, New Jersey; the Austinville Area, Virginia; and the Upper Mississippi Valley area of southwestern Wisconsin and northwestern Illinois.<sup>21</sup>

Domestic mine production from 1907 to 1957 is shown by regions in Figure I.<sup>22</sup>

### Zinc Reserves

Measured and indicated zinc ore reserves in the United States were estimated at about 13.5 million tons in 1957,<sup>23</sup> but because this estimate was based on economic and technological conditions as they existed at that specific time, the estimate may no longer be valid.

Under a free economic system, the tonnage of reserves in a given deposit depends upon the price-cost differential, which determines the cut-off grade as well as the average mining grade. What may be a large reserve of low grade ore under favorable conditions will become a smaller reserve if the higher-grade material has to be selectively mined under less favorable conditions. Once a deposit is mined under such conditions, the total reserve cannot revert to the original tonnage by achieving a more favorable price-cost differential that initially would have allowed mining the whole tonnage; instead, much more favorable conditions, usually in the form of a much higher price, have to prevail. Thus, irrespective of changes due to mining, the quantity of recoverable metal in a given district will vary from time to time, depending on economic conditions.<sup>24</sup>

Another factor that prevents more accurate measurement of reserves can be attributed to the mining companies who withhold information on the basis that it could affect their competitive position in the industry.

---

<sup>21</sup>Mineral Facts and Problems, p. 982.

<sup>22</sup>Materials Survey; Zinc, Bureau of Mines (Washington, 1951), pp. IV-85-93; Minerals Yearbooks 1951-1957.

<sup>23</sup>Minerals Yearbook 1957, p. 1320.

<sup>24</sup>Materials Survey; Zinc, p. III-7.

FIGURE I  
ZINC MINE PRODUCTION IN U.S. 1907-1957

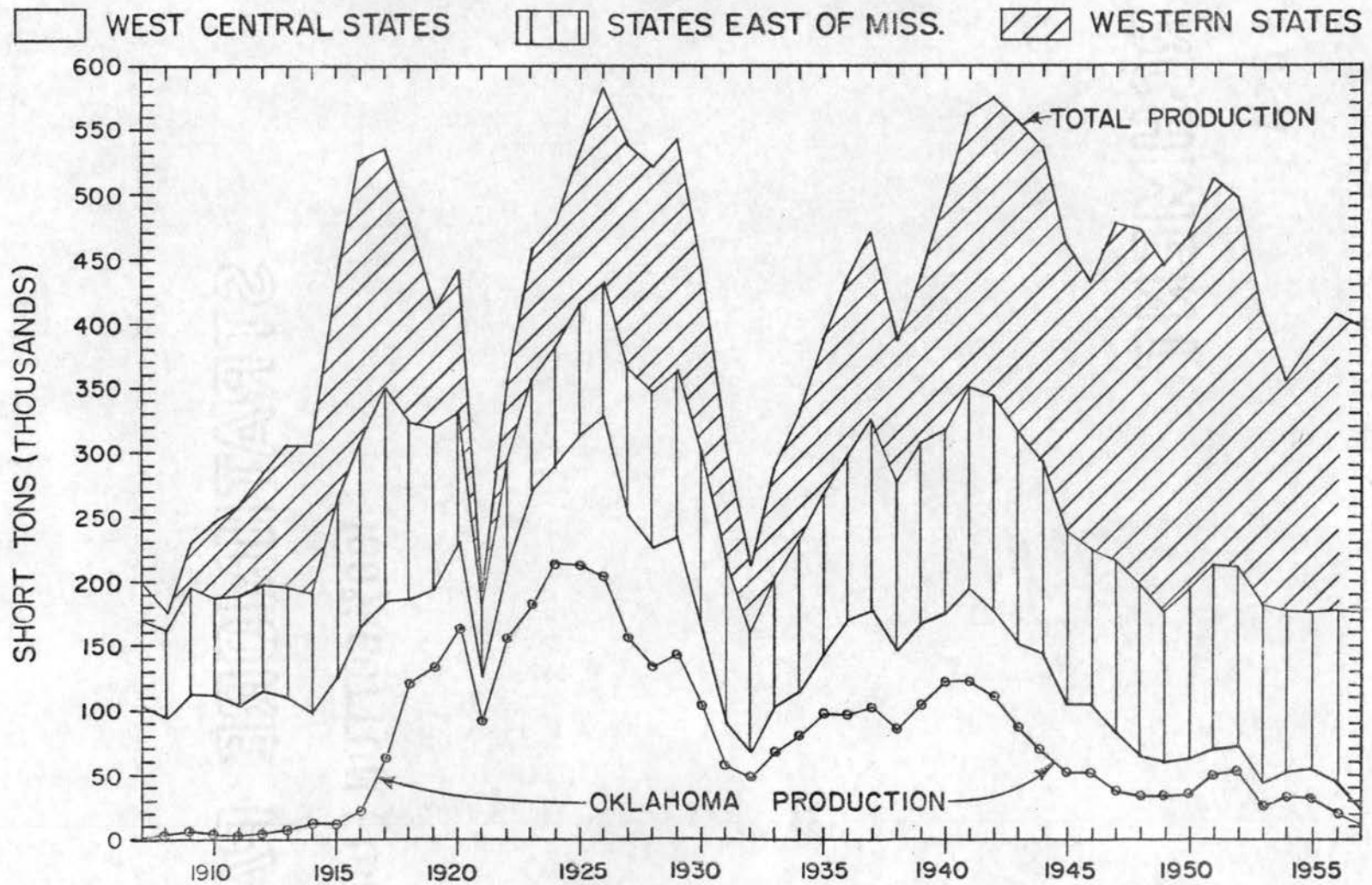

"Reserves cannot be even roughly estimated by anyone who does not have access to company maps and assay data."<sup>25</sup>

In 1949 nearly two-thirds of the zinc reserves were associated with the primary lead and zinc mining districts.<sup>26</sup> Figure 2 shows the location and estimated quantity of these reserves. Areas containing reserves are identified in Table I.

World zinc reserves of the indicated and measured classification were estimated at 84.5 million tons in 1957. Reserves were widely distributed on all continents but detailed information on reserves is not available. Table II lists the estimated world zinc reserves with economic conditions as they prevailed in January, 1957.

#### Zinc Smelting

The modern zinc smelting industry began at Liege, Belgium, in 1806, and for the next century Belgium and German smelters produced about 70 percent of the world's zinc.<sup>27</sup>

Commercial production of zinc in the United States began in 1858 at the works of the Lehigh Zinc Company, South Bethlehem, Pennsylvania. By 1860 smelters had been built at Friedensville, Pennsylvania; Newark, New Jersey; and La Salle, Illinois. Construction of smelting facilities continued as rich new ore reserves were discovered and the demand for zinc increased. Zinc slab production had increased to 25,000 tons by 1880, and 13 smelters were in operation. Domestic production had more

---

<sup>25</sup>H. W. Voskuil, Minerals in World Industry (New York, 1955), p. 218.

<sup>26</sup>Ibid., p. 223.

<sup>27</sup>Alex Skelton et al., International Control of Non-Ferrous Metals (New York, 1937), pp. 691-692.

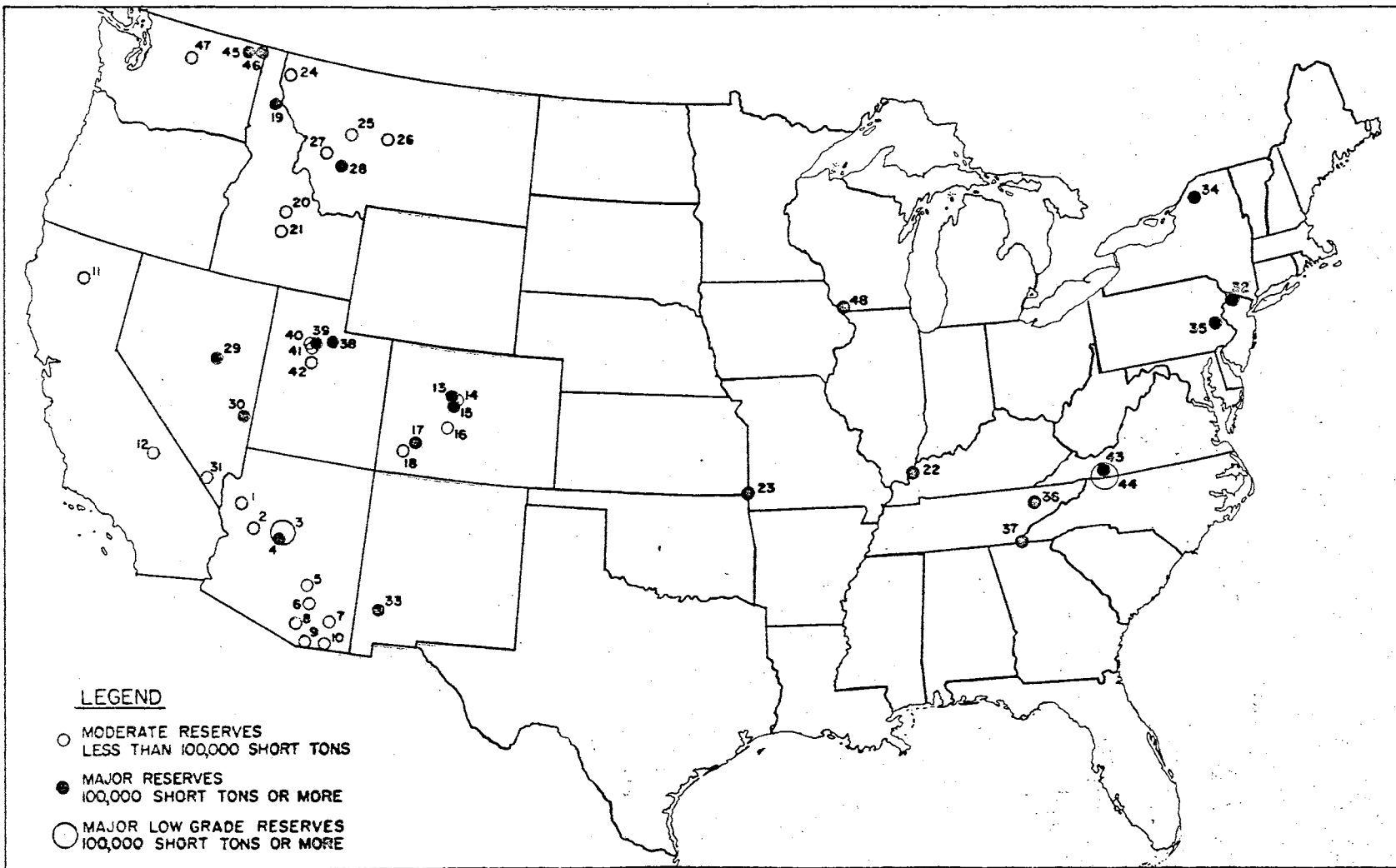

ZINC RESERVES IN THE UNITED STATES 1950  
FIGURE 2



TABLE I  
DISTRICTS OR REGIONS CONTAINING ZINC RESERVES IN 1950<sup>28</sup>

---



---

ARIZONA	NEVADA
1. Wallapai	29. Eureka
2. Eureka	30. Pioche and Comet
3. Jerome	31. Goodsprings
4. Big Bug	NEW JERSEY
5. Superior	32. Franklin
6. Old Hat	NEW MEXICO
7. Cochise	33. Central
8. Pima	NEW YORK
9. Harshaw	34. St. Lawrence County
10. Bisbee	OKLAHOMA-KANSAS-MISSOURI
CALIFORNIA	23. Tri-State
11. Shasta	PENNSYLVANIA
12. Darwin	35. Friedensville
COLORADO	TENNESSEE
13. Red Cliff	36. Eastern Tennessee
14. Kokomo	37. Ducktown
15. Leadville	UTAH
16. Tomichi	38. Park City
17. San Juan	39. Bingham
18. Rico	40. Rush Valley
IDAHO	41. Ophir
19. Coeur d' Alene	42. Tintic
20. Bayhorse and Boulder Creek	VIRGINIA
21. Warm Springs	43. Austinville
ILLINOIS	44. Gossan Lead Belt
22. Southern Illinois-Kentucky	WASHINGTON
MONTANA	45. North Port and Colville
24. Troy and Libby	46. Metaline
25. Heddleston	47. Chelan Lake
26. Barker	WISCONSIN-ILLINOIS-IOWA
27. Philipsburg	48. Upper Mississippi
28. Butte	Valley

---



---

than doubled by 1890, and it nearly doubled again during the next ten years. In 1909 the United States produced 255,760 tons of zinc slab and since that time this country has remained the world's leading zinc slab

<sup>28</sup>Materials Survey; Zinc, p. III-5.

TABLE II  
ESTIMATED WORLD ZINC RESERVES JANUARY, 1957<sup>29</sup>  
(MEASURED AND INDICATED)

Location	Zinc Content-Short tons
North America	37,000,000
Australia	11,000,000
South America	6,000,000
Eastern Europe	11,000,000
Western Europe	11,000,000
Africa	4,000,000
Asia	4,500,000
Total	84,500,000

producer.<sup>30</sup> Domestic zinc slab production reached an all-time high of 1,058,277 tons in 1957, about 2,500 tons above the previous production record set in 1956.<sup>31</sup>

Several technological advances between 1900 and 1930 contributed to domestic production. In 1914 an electrolytic process was developed for zinc ore reduction, but it required considerable low-cost electric power. Within two years this new process was being utilized commercially

<sup>29</sup>Minerals Yearbook 1957, p. 1320.

<sup>30</sup>Materials Survey; Zinc, pp. VI-5-7.

<sup>31</sup>Minerals Yearbook 1957, pp. 1294-1297.

at Great Falls, Montana, by the Anaconda Mining Company. Electrolysis permitted greater use of many complex ores that contained excessive silver, lead and cadmium.<sup>32</sup> It also produced a product of increased purity and permitted the recovery of precious metals.

The complexity of western ores continued to block wide scale exploitation of large known reserves. These ores required special treatment prior to reduction and the cost for this treatment was prohibitive. In 1925 this problem was partially eliminated when a low cost, bulk floatation process was developed. Later a selective floatation process was added and the competitive position of western ores was greatly increased.<sup>33</sup>

The third major development was the introduction of the vertical retort in 1929. This process increased smelter efficiency to about 90 percent of the zinc content. The capacity of the furnace was increased and the new design permitted mechanical charging at the top of the furnace and removal of residue from the bottom. Heat loss was reduced through continuous operation as contrasted to the cyclical nature of the horizontal retort.<sup>34</sup>

Another important development during this period was the organization of the American Zinc Institute in 1918. This trade organization was composed of mining, smelting and manufacturing interests. "The purpose of the Institute is to promote the welfare of the zinc industry

---

<sup>32</sup> Ingalls, World Survey of the Zinc Industry (New York, 1931), pp. 38-39.

<sup>33</sup> Elizabeth S. May et al., International Control of Non-Ferrous Metals (New York, 1931), p. 769.

<sup>34</sup> Edward H. Snyder and Ernest V. Gent, "The Zinc Industry," The Development of American Industries, eds. John G. Glover and William B. Cornell (3d ed., New York, 1951), pp. 371-372.

by affording a means of communication between members upon matters bearing upon their business interests."<sup>35</sup> Since its inception this organization has expanded its activities into the field of research. It also acts as a centralized information agency on all matters pertaining to the zinc industry and its products.

The zinc industry is composed of both integrated and independent companies. At the present time large vertically integrated companies that combine extensive mining operations, smelting or refining, and fabrication, produce the major portion of zinc slab in the United States.<sup>36</sup>

Smelting companies that process mostly purchased concentrates are known as custom smelters. In some cases custom smelters purchase ore from either foreign or domestic sources, process it, and then sell their product. However, these smelters often process ore on a toll basis with the mining company retaining ownership of the products.<sup>37</sup>

In 1957 there were eighteen primary and thirteen secondary zinc plants in operation in the United States. The primary smelters are classified into four groups based on the reduction process they use. Nine are classed as horizontal retort smelters, four are vertical retort smelters, five use the electrolytic process and one is classed as an electro-thermic zinc slag furnace. The total capacity of all these plants was 1,162,600 tons in 1957, during that year they ran at about 88 percent capacity.<sup>38</sup>

---

7 (35) Ibid., p. 390.

8 (36) Materials Survey; Zinc, p. VI-18.

9 (37) Ibid., pp. VI-14-15.

10 (38) Minerals Yearbook 1957, pp. 1292-1294.

Primary zinc smelters are concentrated in four geographic regions in the United States. In three of these regions a single method of ore reduction is usually employed. The western region of Montana and Idaho use the electrolytic process exclusively. In the region of Oklahoma, Texas and Arkansas horizontal retort plants are utilized with the exception of an electrolytic plant at Corpus Christi, Texas. Production in the eastern states of West Virginia and Pennsylvania is limited to vertical retort plants. The fourth region is centered in Illinois where three smelters were operating in 1957, each employing a different process. An electro-thermic zinc slag furnace located at Herculaneum, Missouri, can be included in the Illinois Region. Figure 3 shows the geographic location of all zinc smelters in the United States.<sup>39</sup>

At the present time three horizontal retort smelters are located in Oklahoma. These are the plants of Eagle-Picher Company at Henryetta; National Zinc Company at Bartlesville; and American Metal Climax, Inc., at Blackwell.

The secondary zinc smelting industry had thirteen plants operating in 1957. They produced about 37,266 tons of slab zinc and shared in the production of 6,400 tons of remelt zinc and 26,700 tons of zinc dust. Secondary smelters are designed to utilize zinc-base scrap in their process. This scrap is usually obtained from galvanizers and zinc dealers in the form of zinc skimmings, drosses, chemical residues or new clippings, but they also use old zinc, engravers plates and die cast alloys.<sup>40</sup>

---

<sup>39</sup>Ibid., p. 1293.

<sup>40</sup>Ibid., p. 1294.

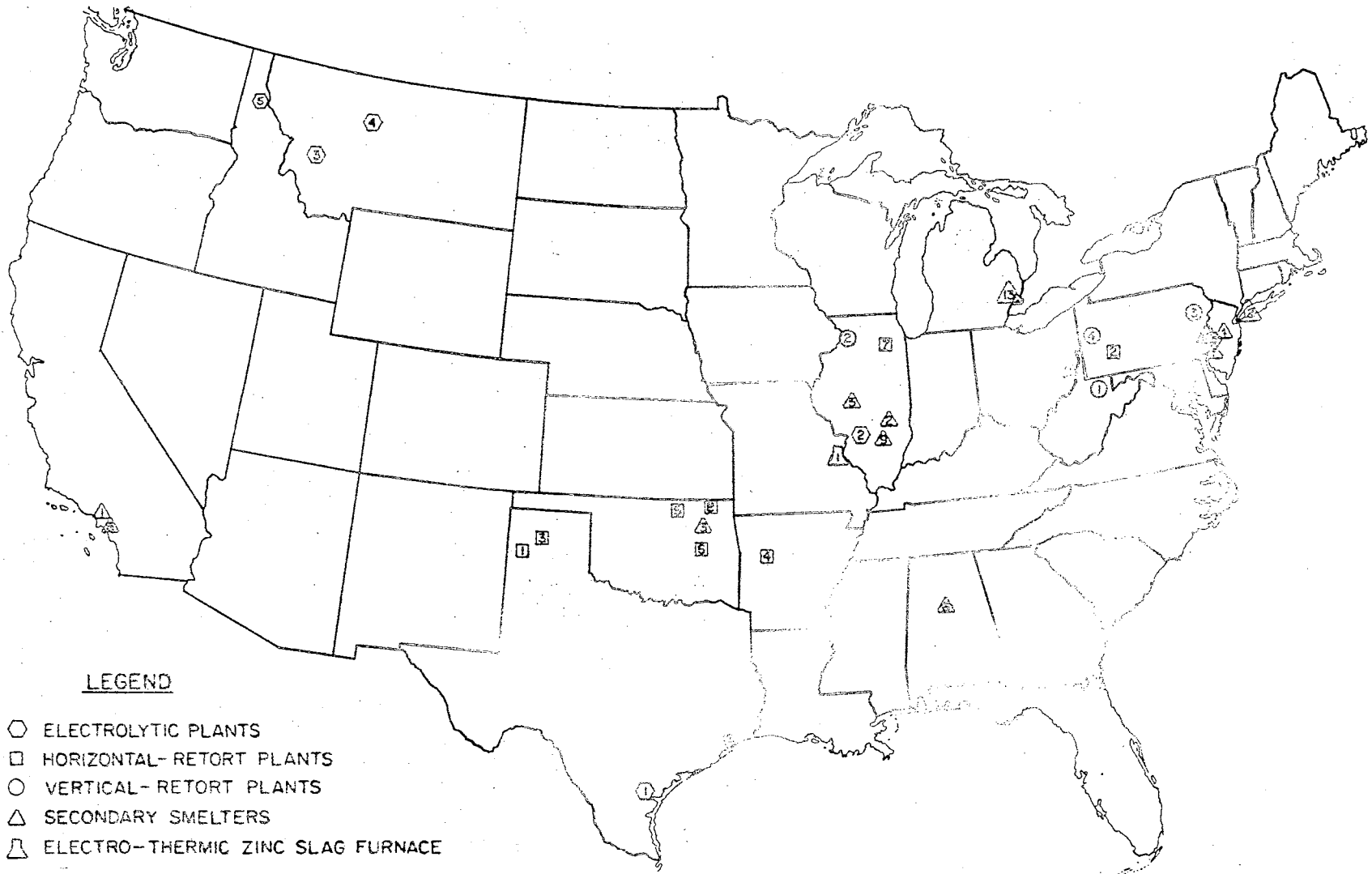

LEGEND

- ELECTROLYTIC PLANTS
- HORIZONTAL-RETORT PLANTS
- VERTICAL-RETORT PLANTS
- △ SECONDARY SMELTERS
- △ ELECTRO-THERMIC ZINC SLAG FURNACE

LOCATION OF ZINC SMELTING AND REFINING PLANTS IN THE UNITED STATES 1957  
 FIGURE 3

TABLE III  
PRIMARY ZINC DISTILLERS OPERATING IN 1957

Company	Location
Electrolytic Refining Plants	
American Smelting and Refining Co. (1)	Corpus Christi, Texas
American Zinc Co. of Illinois (2)	Monsanto, Illinois
Anaconda Co. (3)	Great Falls, Montana
Anaconda Co. (4)	Anaconda, Montana
Bunker Hill Co. (5)	Silver King, Idaho
Horizontal Retort Smelters	
American Smelting and Refining Co. (1)	Amarillo, Texas
United States Steel Corp. (2)	Donora, Pennsylvania
American Zinc Co. of Illinois (3)	Dumas, Texas
Athletic Mining and Smelting Co. (4)	Fort Smith, Arkansas
American Metal Climax, Inc. (5)	Blackwell, Oklahoma
Eagle-Picher Co. (6)	Henryetta, Oklahoma
Matthiessen and Hegeler Zinc Co. (7)	La Salle, Illinois
National Zinc Co. (8)	Bartlesville, Oklahoma
Vertical Retort Smelters	
Matthiessen and Hegeler Zinc Co. (1)	Meadowbrook, West Virginia
New Jersey Zinc Co. (2)	Depue, Illinois
New Jersey Zinc Co. of Pennsylvania (3)	Palmerton, Pennsylvania
St. Joseph Lead Co. (4)	Josephtown, Pennsylvania
Electro-Thermic Slag Furnace	
New Jersey Zinc Co. (1)	Herculaneum, Missouri

TABLE IV  
SECONDARY ZINC DISTILLERS  
1957

Company	Location
American Smelting and Refining Co.	
Federated Metals Division:	
Los Angeles Plant (1)	Los Angeles, California
Beckemeyer Plant (2)	Beckemeyer, Illinois
Sand Springs Plant (3)	Sand Springs, Oklahoma
Trenton Plant (4)	Trenton, New Jersey
American Zinc Co. of Illinois (5)	Hillsboro, Illinois
W. J. Bullock, Inc. (6)	Fairfield, Alabama
General Smelting Co. (7)	Philadelphia, Pennsylvania
Pacific Smelting Co. (8)	Torrance, California
Sandroval Zinc Co. (9)	Sandroval, Illinois
Superior Zinc Co. (10)	Bristol, Pennsylvania
Wheeling Steel Corp. (11)	Martin's Ferry, Ohio
Nassau Smelting & Refining Co. (12)	Tottenville, New York
Arco Die Cast Metals Co. (13)	Detroit, Michigan

Oklahoma's only secondary zinc plant is operated by American Smelting and Refining Co., Federated Metals Division, at Sand Springs.



## CHAPTER II

### METALLURGY OF ZINC

The metallurgical processes presented in this chapter will be limited primarily to those employed at a typical horizontal retort smelter; however, some of the techniques utilized during the mining and milling operations are discussed briefly. A brief description of the process used by some secondary zinc plants for production of zinc dust is also included. No

#### Recovery of Primary Zinc

The properties of a metal are always significant in determining the metallurgical processes employed in recovering the metal from its ores. Zinc's high volatility at temperatures below the reduction temperatures of its compounds permit its recovery as a vapor with subsequent condensation and cooling into solid form. The principal methods used for production of zinc slab are shown in Figure 4. Y

#### Concentration

Prior to smelting, zinc ores have passed through several processes designed to increase their zinc content by removing waste materials. During the mining operation only ore containing enough valuable minerals to permit profitable exploitation is moved to the surface. Waste is removed as the ore-bearing rocks are crushed both in the mine and later at the milling plants.

FIGURE 4  
 BASIC PROCESSES OF PRIMARY ZINC SLAB PRODUCTION<sup>1</sup>

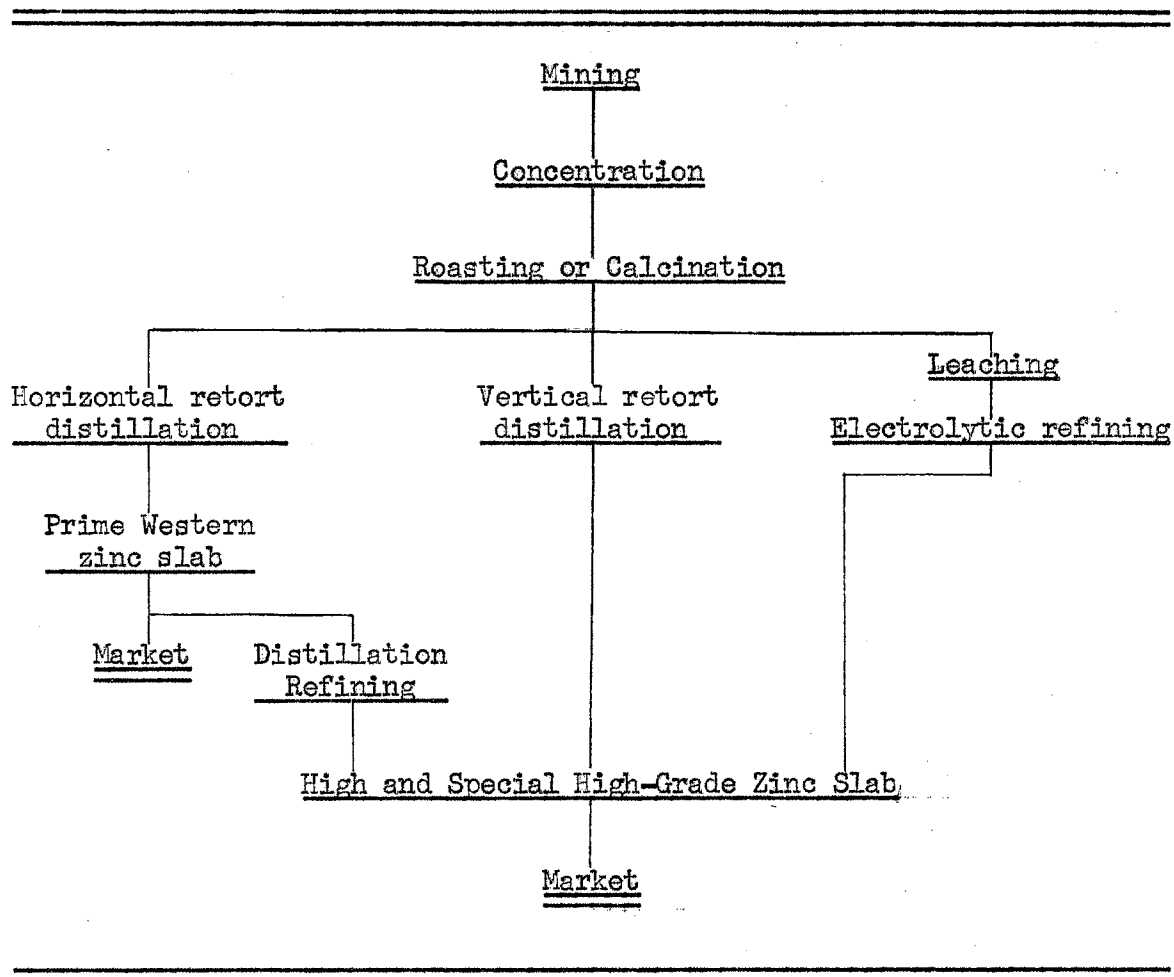

From the mine the crude ore is transported to the mill which is usually located nearby because of prohibitive transportation costs. At the mill crushing, grinding and concentration take place. The ore is passed through either jaw or cone crushers to reduce its size to about one-half inch. Further milling reduces the ore to small particles about one-hundredth inch in diameter. After the grinding process is completed

<sup>1</sup> Materials Survey; Zinc, Bureau of Mines (Washington, 1951), p. II-15.

and the metallic mineral grains have been released, separation from waste materials can be accomplished by any of several methods.<sup>2</sup>

"Gravity" concentration is based on the differences in the specific gravity of the minerals. The heavy metallic minerals nearly always settle faster when placed in an agitated fluid media.<sup>3</sup>

"Magnetic" concentration utilizes the magnetic properties of various minerals. This method is well suited for the zinc ores found in the Franklin district, New Jersey.<sup>4</sup>

"Floatation" separation takes advantage of the fact that some metal sulfide particles will adhere to the froth produced by agitation of some liquid media. As the small bubbles rise to the surface carrying the fine metal particles, they are mechanically raked into a flume for collection.<sup>5</sup>

A fourth method, known as "differential-density" separation, has recently been developed. This process employs a liquid medium with a density slightly lighter than zinc and slightly heavier than gangue. When ore is placed in this liquid the zinc slowly settles to the bottom and the waste is floated off the top.<sup>6</sup>

In any event, the zinc content has been increased by the concentration process from 100 pounds per ton of raw ore to about 1200 pounds per ton of concentrates. This is a concentration ratio of 12:1 which offers its own answer as to why this part of the winning of the metal must necessarily be located proximate, if not adjacent, to the source of ore.<sup>7</sup>

---

2 Ibid., pp. II-16-18.

3 Ibid., p. II-18.

4 Ibid., p. II-24.

5 Ibid., p. II-25.

6 Carl H. Cotterill, Industrial Plant Location, Its Application to Zinc Smelting (Saint Louis, 1950), pp. 45, 48.

7 Ibid., p. 48.

## Smelting

Horizontal retort smelting involves several processes as shown in Figure 5. This flow sheet is for a typical smelter; however it must be recognized that these processes vary from one smelter to another and alternate methods are often employed.

FIGURE 5  
HORIZONTAL RETORT ZINC SMELTER FLOW SHEET<sup>a</sup>

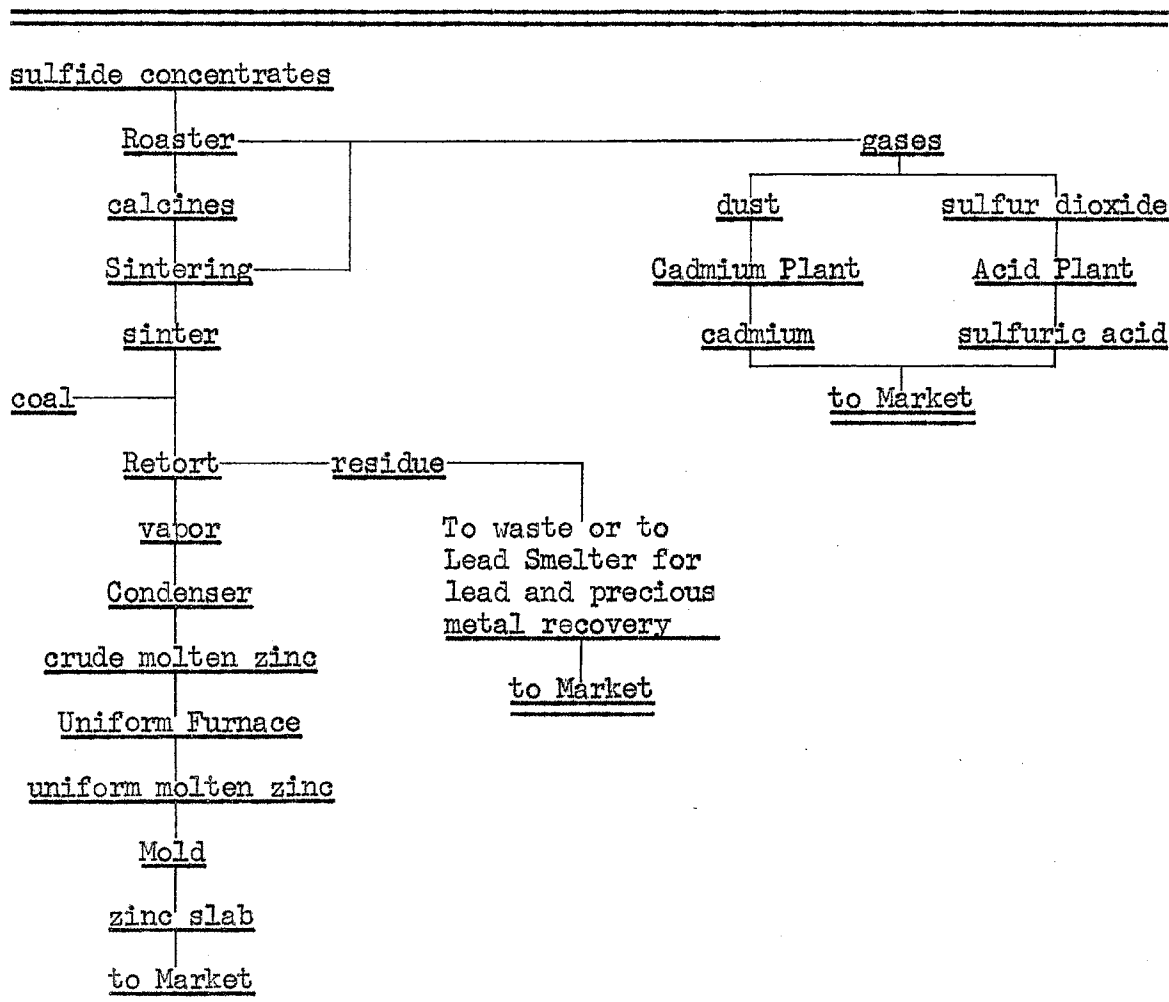

<sup>a</sup>All processes are capitalized; products are not.

## Roasting

Roasting is the preliminary step for all concentrates containing zinc sulfides, as any sulfur present will retain nearly twice its weight of zinc in retort residues. During the roasting process heat and oxygen are applied to convert the sulfides into a higher state of oxidation.

Roasting can be accomplished in any of several types of furnaces. However, smelters today usually employ either a Hegeler multiple hearth furnace or a Fluo Solids fluid-bed reactor. The more modern fluid-bed reactor has replaced the older Hegeler type roasters at some smelters during the past. The Hegeler furnace was designed to roast sulfides slowly and completely under dynamic conditions. Concentrates are fed into the furnace at the top. Heated gases which are sealed off from the combustion area are forced upward through the charge. The temperature of the concentrates increases as the charge is forced downward by mechanically operated rakes. The heated concentrates react with excess oxygen to produce zinc oxide and sulfur dioxide gas, reducing the sulfur content from 24 to about one or two percent. The general equation may be expressed as follows:<sup>8</sup>  $2\text{ZnS} + 3\text{O}_2 = 2\text{ZnO} + 2\text{SO}_2$ .

The Fluo Solids Reactor has the same function as the older type roasters, but it accomplishes its purpose somewhat differently. Zinc sulfide concentrate, which has been mixed with 20 percent water to form a slurry, is pumped into the reactor. Huge blowers force large quantities of air to bubble up through the hot liquid media which occupies about the lower one-third of the reactor. As the oxygen passes through the fluid it reacts with the zinc sulfide producing zinc oxide and sulfur

---

7 (8) Cotterill, p. 48.

dioxide. Calcine is discharged from the reactor through overflow ports and it is also recovered from the stack gases as a dust.<sup>9</sup>

### Sintering

After the roasting process is completed the resulting zinc oxide or calcine is too fine or closely packed to permit treatment in the retort furnace. The primary objective of the sintering process is to produce a clinker or porous material which would permit free passage of gases and zinc vapor. Sintering also removes additional sulfur and other volatile impurities such as cadmium, arsenic, antimony, bismuth or lead.

Several types of sintering machines have been developed, but the continuous, straight-line, down draft type designed by Dwight-Lloyd is now most widely used. Calcine mixed with about ten percent coal is dampened to provide permeability, then spread onto slowly moving perforated pallets or grates to a height of four to nine inches. As the charge moves into the oven it passes through a combustion area where the top of the charge is ignited. Suction, developed by huge wind boxes sealed at the bottom of the grates, causes the charge to burn downward. After ignition, oxidation becomes vigorous and the heat generated causes fusion of the calcine particles. Gases produced during the sintering process are carried through the wind boxes to a collecting system or released to the atmosphere. As the clinker or sinter cake emerges from the furnace it falls into a conveyor or waiting car for transportation to storage or to the crushing machine. After crushing and grinding the sinter material is suitable for reduction by distillation which follows.<sup>10</sup>

---

18 (9) J. S. Van Aken, Smelter Superintendent, National Zinc Co., Bartlesville, Oklahoma, Personal Interview, (June 9, 1959).

19 (10) Materials Survey; Zinc, pp. II-33-35.

## Distillation

The distillation process employed at horizontal retort smelters was developed in Belgium early in the nineteenth century. A typical horizontal retort furnace is composed of a double bank of several hundred retorts. The butt end of each retort is supported in the center of the furnace by a common fire brick wall, and the open or front end of the retort is supported by the enclosing side walls of the furnace. Both ends and the top of the furnace are also enclosed with fire brick.

The clay retorts used are usually nine inches internal diameter, sixty inches in length and have walls about one inch thick. Reduction takes place in the retort at temperatures above 905°C., the boiling point of zinc; consequently, the retorts must be designed to withstand exceedingly rigorous treatment and extreme temperatures ranging from normal ambient to about 1400°C.

Zinc reduction and distillation at a horizontal retort smelter is an intermittent process. The time required for each complete cycle varies from one area to another. At the present time all domestic smelters employ a 48-hour cycle with five scheduled metal "draws" per cycle.<sup>11</sup>

At the beginning of the distillation cycle, zinc-bearing sinter, oxide and bluepowder are combined with 20 percent fine coal, a small amount of water to provide greater porosity, and about one-half percent common salt. This mixture constitutes the charge which is then introduced into the retorts by mechanical chargers. After charging is completed, clay condensers are luted into place at the mouth of the

---

<sup>11</sup>Marvin L. Huguen, Plant Manager, Blackwell Zinc Co., Blackwell, Oklahoma, Personal Interview, (June 3, 1959).

FIGURE 6  
TYPICAL  
HORIZONTAL RETORT DISTILLATION FURNACE

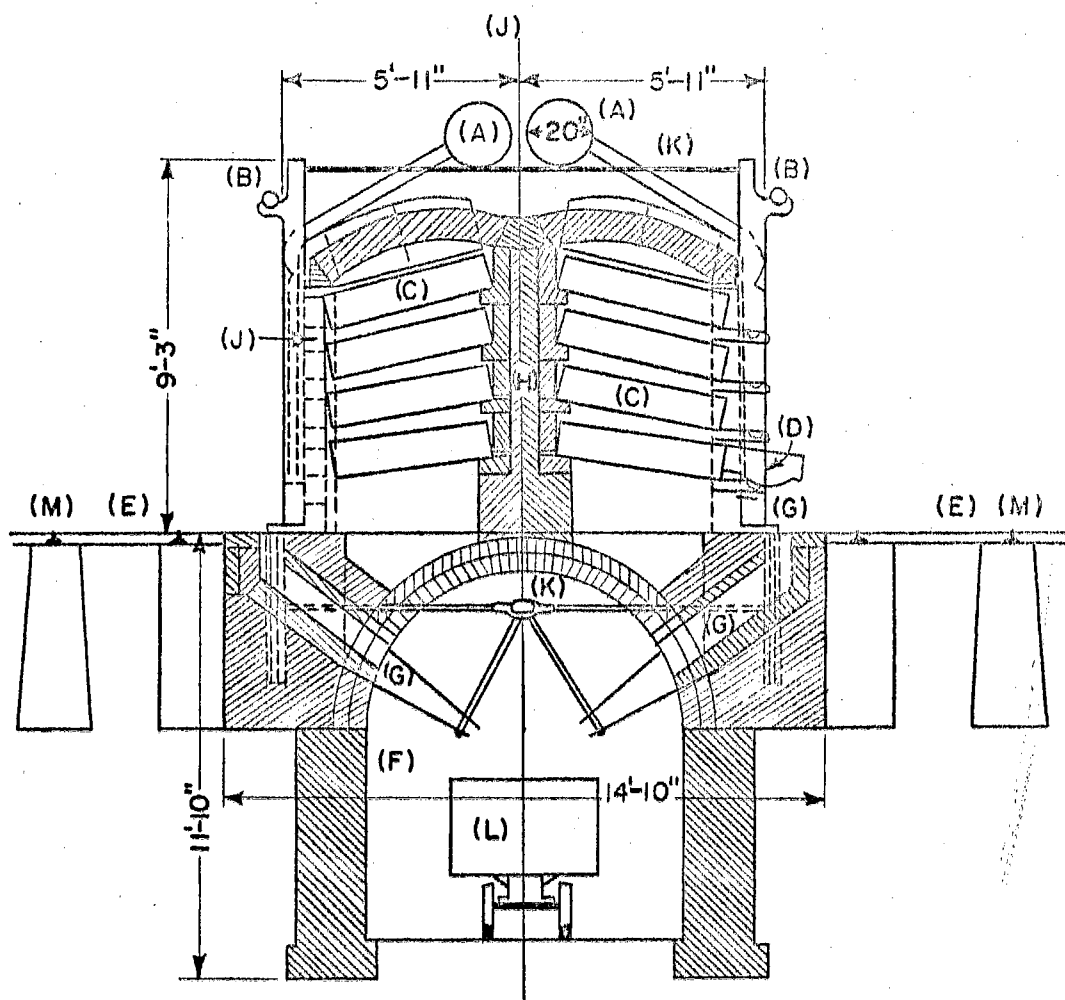

- |                   |  |
|-------------------|--|
| (A) AIR MAIN      | (G) RESIDUE CHUTE                              |
| (B) GAS MAIN      | (H) REAR LINING                                |
| (C) RETORT        | (J) FRONT LINING                               |
| (D) CONDENSER     | (K) TIE RODS                                   |
| (E) WORKING FLOOR | (L) RESIDUE CAR                                |
| (F) RESIDUE PIT   | (M) RAILS FOR CHARGING<br>MACHINE LADLES, ETC. |



filled retorts. Each condenser is then plugged with a mixture of moistened slack coal and loam to prevent the escape of molten zinc as it collects.<sup>12</sup>

After the charging process is completed the temperature of the furnace is progressively increased to about 1400°C. at its peak. This corresponds to a temperature of 1250° - 1300°C. on the inside of the retorts. As the heating process takes place, zinc oxide is vaporized and forced by the pressure of expansion from the retort into the cool condenser where the zinc vapor is liquified. At intervals the liquid zinc is drawn off into large ladles and cast into slabs. Water vapor and volatilized hydrocarbons produced during the process escape through the condensers' mouth to the atmosphere.<sup>13</sup>

After the distillation cycle has been completed, slag and residue are removed from the retorts by mechanically operated scraping tools mounted on a cleaning machine. Furnace residue is collected for processing in the Waelz Kiln. At plants not operating this type kiln the residue is either removed to the slag dump or if the residue contains sufficient quantities of gold, silver or lead to permit further processing, it is first sintered to reduce the carbon content and then shipped to smelters especially designed to accommodate such materials.

#### Waelz Oxide Kiln

The Waelz process which was developed in Upper Silesia in 1925, uses a rotating kiln to concentrate zinc-bearing residues. In this process

---

<sup>12</sup> Bill Clancy, Engineering Department, Blackwell Zinc Co., Blackwell, Oklahoma, Personal Interview, (June 3, 1959).

<sup>13</sup> Cotterill, pp. 52, 57.

retort residues or other zinc oxide materials are mixed with reduction fuel, usually coal or coke, and fed into a rotating kiln similar to a cement kiln. As the charge moves through the hot zone of the kiln zinc and other metals are reduced and volatilized. Immediately the vapors are caught in the moving gas stream and reoxidized. The finely divided oxide is carried out by the gases and collected in woolen bags or by electrostatic precipitation. The zinc oxide recovered by this process is recycled through the retort furnaces and recovered as zinc slab.<sup>14</sup>

#### By-Products

##### Sulfuric Acid

Laws prohibiting the release of obnoxious smelter gases into the atmosphere are common to most urban areas; consequently the sulfur dioxide gases produced during roasting and sintering operations must be controlled. Smelters located near industrial areas have a ready market for sulfuric acid and several smelters burn large quantities of elemental sulfur to increase their acid making capacity.<sup>15</sup> But because of its low per unit value, sulfuric acid is not economically suitable for shipment over great distances. Therefore, smelters situated away from populated areas and markets often send their gases to the atmosphere through a high stack.

Sulfuric acid is produced by oxidizing sulfur dioxide gases to sulfur trioxide. Next, the sulfuric trioxide is combined with water to

---

<sup>23</sup>(14) S. M. Shelton and W. E. Duncan, "Zinc Metallurgy Far From Static," Engineering and Mining Journal (February, 1939), p. 81.

<sup>24</sup>(15) Minerals Yearbook, 1956, p. 1332.

form a weak sulfuric acid. Additional sulfur trioxide is then absorbed to produce the desired strength usually about 78 percent.<sup>16</sup>

### Cadmium

Cadmium is recovered as a by-product from smelter gases produced during the roasting and sintering operations and by the Waelz kiln. Cadmium-bearing dust is removed from these gases by either an electrostatic precipitator or by finely woven, orlon filter bags. After the dust has been collected it is subjected to a series of chemical processes to remove impurities, then the cadmium is precipitated out of solution as a metal sponge. Next, the sponge is either compressed, melted and cast into forms, or it is compressed with coke, distilled in a special type horizontal retort and then cast into desired forms; e.g., sticks, sheets or balls. The cadmium process in turn produces lead and zinc sulfate as by-products.<sup>17</sup>

### Recovery of Secondary Zinc Dust

All secondary zinc smelters are engaged in the redistillation of some form of zinc scrap or residue. The product of these plants is normally either zinc slab or zinc dust and production in most plants can be shifted from one product to the other with only minor changes in equipment. The processes described in this section will be limited to those viewed by the writer at a secondary plant producing zinc dust.

---

25 <sup>16</sup> Cotterill, pp. 57-58.

26 <sup>17</sup> Ibid., p. 61.

## Processes

The production cycle at a secondary plant begins as the raw material is charged into a large graphite retort which is inclosed, except for its mouth or front end, within a furnace. These furnaces are usually constructed in banks; however, each retort is heated separately within its individual furnace section. After charging has been completed, the open end of the retort is partially covered and the temperature increased until the charge reaches a molten or liquid state. At this time the front of the retort is sealed with fire clay and the temperature increased until the interior of the retort exceeds  $905^{\circ}\text{C}.$ , the temperature zinc becomes volatile. As the zinc vapor is produced it passes from the retort into the condenser section where the vapor is frozen; i.e., the vapor is transformed from its gaseous state to a solid state producing a very fine zinc dust. As the dust forms it settles to the bottom of the condenser which serves as a gravity feed hopper.

After the firing cycle is completed the seal is removed from the front of the retort and the residue is chipped out. This residue is removed to a storage area for later shipment to another type of smelter for further processing.

Periodically the dust is removed from the hopper section of the condenser and screened to remove foreign material and zinc particles that are not suitable for the commercial market. Following this initial screening the remaining dust is processed by a screening machine which separates the dust particles into three commercial sizes. After sizing, the dust is packaged in metal containers of various sizes and sent to the warehouse for storage or shipment.

## CHAPTER III

### ZINC PRODUCTS, FOREIGN TRADE AND NATIONAL POLICY

Zinc is a bluish-white, nonferrous metal with a density of 7.1. At ordinary temperatures it is brittle, but at 120°C. zinc becomes malleable and can be rolled into sheets or drawn into wire. Zinc melts at 419°C. and boils at 905°C.<sup>1</sup>

The commercial importance of zinc is based largely upon its use as a corrosion inhibitor, especially as a protective coating on steel. When zinc is exposed to the atmosphere it is coated with a film of carbonate and becomes very resistant to corrosion. Zinc is also frequently alloyed with other metals to produce a great variety of useful products as shown in Figure 7.<sup>2</sup>

#### Zinc Slab

Metallic zinc is generally marketed in the form of ingots or slabs, hence the name "zinc slab." Each smelter casts its product into slabs of various shapes and sizes to facilitate handling and shipping. Zinc slabs normally weigh between 57 and 63 pounds; however, slabs weighing several hundred pounds are produced at some integrated plants.

---

<sup>1</sup>George S. Brady, Materials Handbook (8th ed., New York, 1956), p. 890.

<sup>2</sup>Edward H. Snyder and Ernest V. Gent, "The Zinc Industry," The Development of American Industries, eds., John G. Glover and William B. Cornell (3d ed., New York, 1951), p. 384.

# THE FLOW OF ZINC FROM MINE TO MARKET . . .

In this diagram are shown the primary derivatives and by-products of the reduction of zinc ore, and a partial list of their many and varied applications.

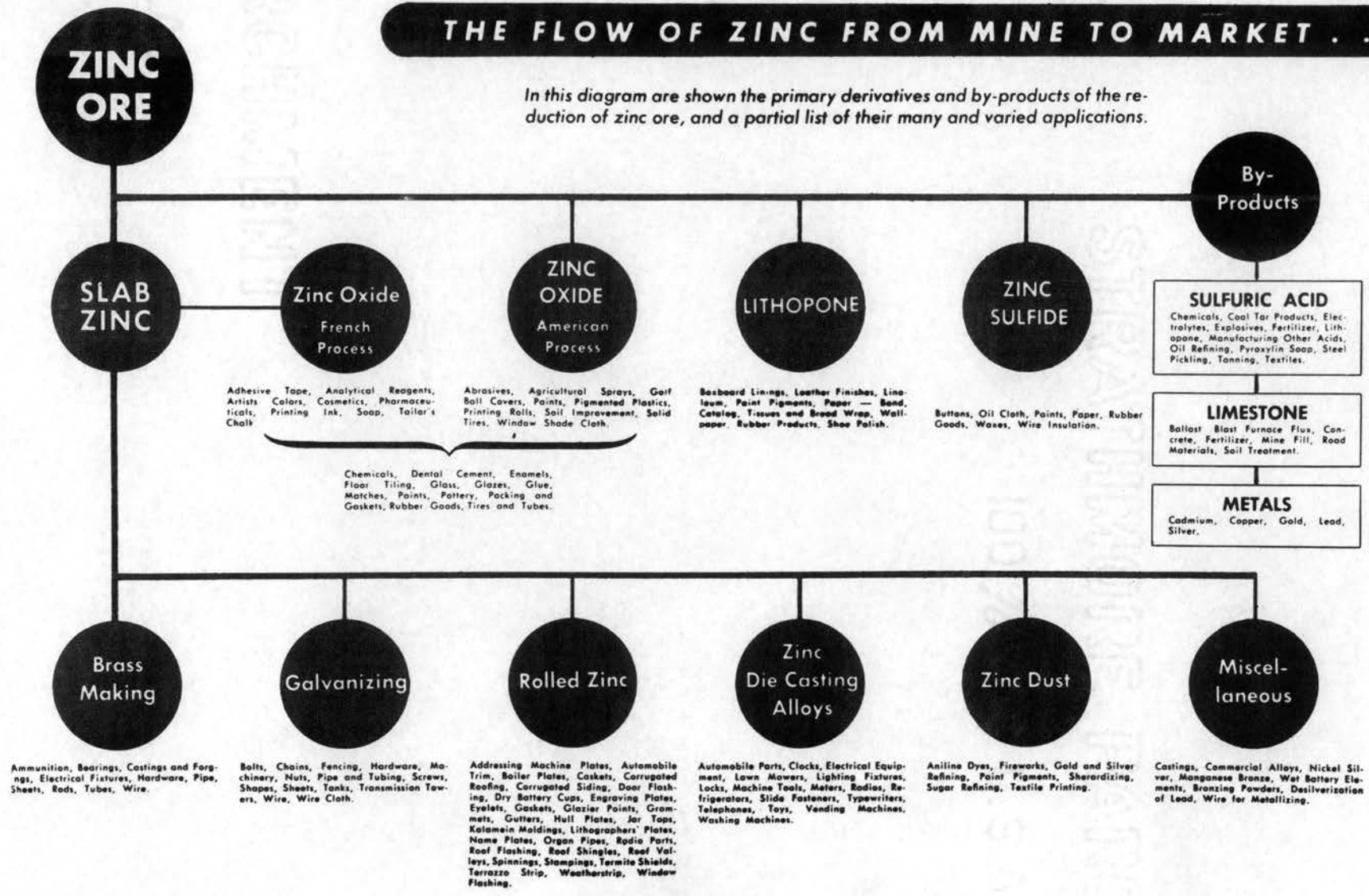

Figure 7. The Flow of Zinc From Mine to Market.  
(Courtesy of the American Zinc Institute)

## Grades

Zinc slab is usually smelted to certain specifications depending upon the process used and the purity desired. In 1949 the American Society for Testing Materials established criterion for six commercial grades of primary zinc slab. The minimum zinc content for these grades ranges from 98.32 percent for Prime Western to 99.99 percent for Special High Grade. All commercial grades are free from aluminum and the presence of lead, iron and cadmium is limited as shown in Table V.

TABLE V  
STANDARD SPECIFICATIONS FOR ZINC SLAB<sup>3</sup>  
(MAXIMUM IMPURITIES ALLOWED)

Name	Lead	Iron	Cadmium	Total
Special High Grade	0.006	0.005	0.005	0.010
High Grade	.070	.020	.070	.100
Intermediate	.200	.030	.500	.500
Brass Special	.600	.030	.500	1.000
Selected	.800	.040	.750	1.250
Prime Western	1.600	.080	-----	-----

Production of zinc slab by grade is shown in Table VI.

## Prices

Domestic zinc prices are usually quoted in cents per pound, f.o.b. East St. Louis, Illinois. The standard quotation is for Prime Western,

<sup>3</sup>Yearbook of the American Bureau of Metal Statistics for 1957  
(York, 1958), p. 85.

TABLE VI

ZINC SLAB PRODUCTION BY GRADE, 1957<sup>4</sup>

Grade	Production	Percent of Total
Special High Grade	354,000	33.3
High Grade	152,000	14.3
Intermediate	32,000	3.0
Brass Special	88,000	8.3
Select	1,000	0.1
Prime Western	<u>434,000</u>	<u>41.0</u>
Total	1,058,000	100.0

which is the least pure of the six market grades and has the largest use. Prices for the other five grades of zinc slab are integrated with the quotation for Prime Western and normally demand established premiums over this price.<sup>5</sup>

The average price of Prime Western f.o.b. East St. Louis has fluctuated widely since 1900 as shown in Figure 8. It has ranged from a low of 2.88 cents per pound in 1932 to 18.0 cents per pound in 1951. The general trend has been upward during this period. The average price

<sup>4</sup>Minerals Yearbook 1957, Part I, Bureau of Mines (Washington, 1958) p. 1297.

27 <sup>5</sup>Snyder and Gent, p. 386.



FIGURE 8

AVERAGE PRICE OF PRIME WESTERN AT EAST ST. LOUIS 1900-1957

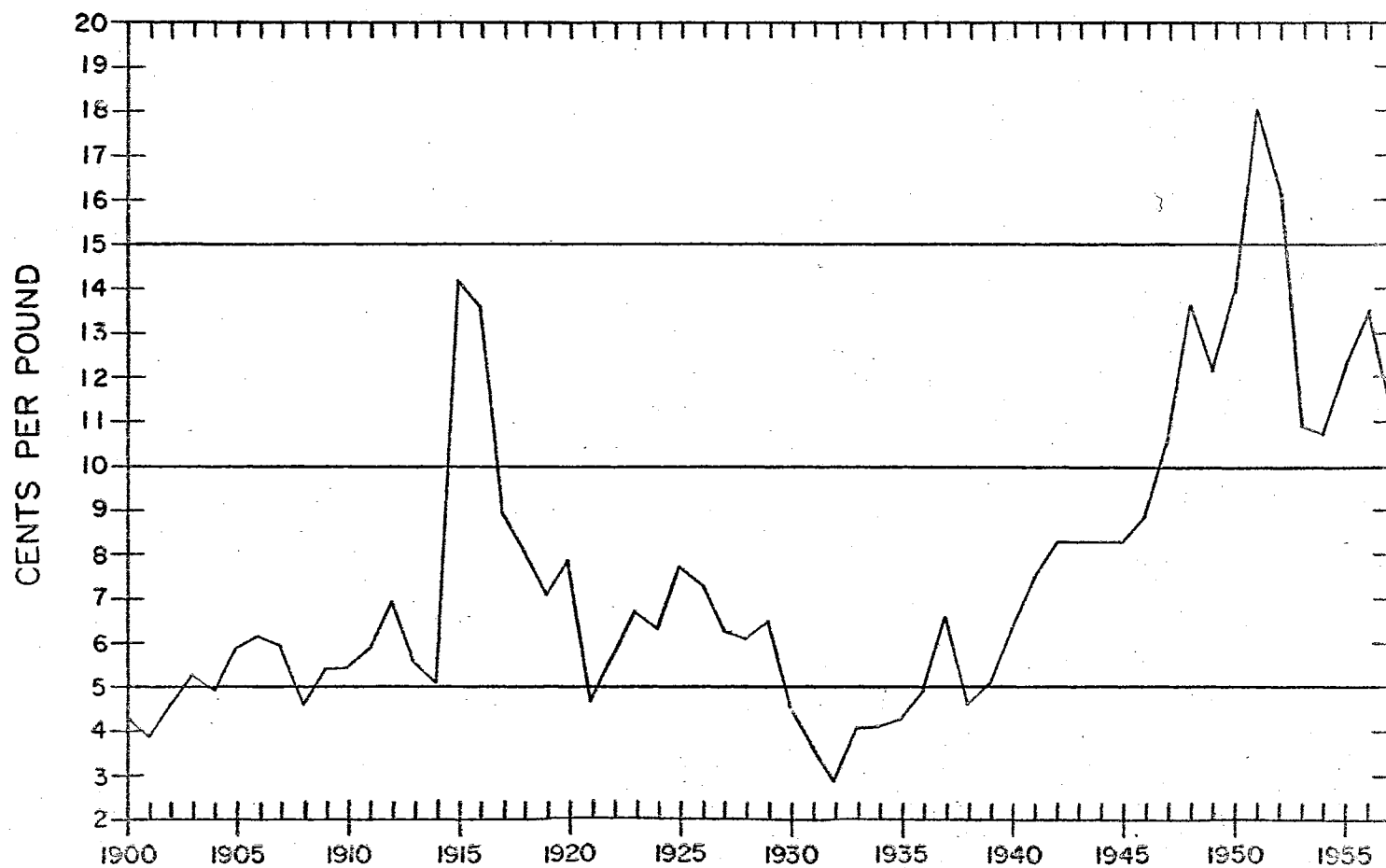

paid from 1900 to 1910 was 5.08 cents per pound as compared with the 1947-1957 average price of 13.06 cents per pound.<sup>6</sup>

### Consumption

Domestic consumption of slab zinc reached a record high in 1955 when 1,119,812 tons were used. Consumption decreased about nine percent in 1956 and it declined about seven percent more in 1957. In 1957 the tonnage of zinc used for die casting exceeded the amount consumed by the galvanizing industry for the first time. These two industries consumed nearly 80 percent of all zinc slab used. Other important consumers include the brass mills, the rolled zinc industry and zinc oxide producers.<sup>7</sup>

Consumption of slab zinc in the United States is centered in the highly industrialized areas of the midwest and northeast. The die casting industry is associated primarily with the automobile industry and is located in the same general areas. The iron and steel industry is the largest consumer of slab zinc for galvanizing. Brass mills and rolled zinc fabricators are also located adjacent to the large industrial regions. About one-third of the zinc slab consumed for brass making is used by mills located in the "Brass Valley" of Connecticut.

Figure 9 shows consumption of zinc slab by states in 1956. Five states--Ohio, Illinois, Pennsylvania, Michigan and Indiana--consumed

---

<sup>28</sup> (6) Materials Survey; Zinc, Bureau of Mines (Washington, 1951), p. IV-143.

<sup>29</sup> (7) Charles R. Ince, "Zinc," Engineering and Mining Journal, Vol. 159 (February, 1958), pp. 136, 167.



ZINC SLAB CONSUMPTION BY STATES 1956  
FIGURE 9

TABLE VII  
ZINC SLAB CONSUMPTION BY INDUSTRIES<sup>8</sup>

	1957 <sup>a</sup>	1956	Percent Change
Galvanizing	363,000	439,000	- 15
Die Casting	375,000	360,000	+ 4.2
Brass Mills	111,000	124,000	- 11.5
Rolled Zinc	41,000	47,000	- 12.8
Oxide	21,000	19,000	+ 10.5
Other	<u>25,000</u>	<u>20,000</u>	<u>+ 25.0</u>
Total	935,000	1,009,000	- 7.0

<sup>a</sup>1957 estimated.

about 64 percent of the total domestic consumption. Oklahoma ranked 24th nationally, using only 2,190 tons of zinc slab during 1956.<sup>9</sup>

#### Other Associated Products

##### By-Products

Sulfuric acid is the principal by-product of the zinc smelting industry. It is obtained by removing sulfur dioxide from the gasses released during the roasting and sintering operations. Nearly 991,000 tons of 100 percent sulfuric acid was produced in 1957 and it was valued at nearly 18 million dollars.<sup>10</sup>

<sup>8</sup>Ibid., p. 136.

<sup>9</sup>Minerals Yearbook 1956, p. 1336.

<sup>10</sup>Minerals Yearbook 1957, p. 1298.

Domestic production of cadmium, the principal metal by-product of Oklahoma's smelters, averaged 10.6 million pounds in 1956 and 1957. Cadmium prices held at about \$1.70 per pound from 1954 through 1957, but in December, 1957 prices declined to \$1.55 per pound.<sup>11</sup>

Several other metals are also recovered during the smelting process. These include lead, copper, silver, mercury and gold. Although these metals are recovered in rather small quantities, smelters obtain some value from their sale.

#### Other Products

##### Zinc Dust

Commercial grade zinc dust is produced as a by-product at some primary smelters and as a primary product at some secondary plants; however, the secondary plants are the major producers.

The early market for zinc dust was mainly in the west where it was used in the cyaniding process for recovering precious metals. More recently the sherardizing process of galvanizing created a market in steel processing areas of the country.<sup>12</sup>

Today zinc dust has many varied uses in the chemical, textile, petroleum, paper and metals industries. Sherardizing is the most important user of zinc dust, but the smelting and refining industries are also large consumers. The chemical industry uses vast quantities of zinc dust as a reducing agent in the synthesis of dye intermediates

---

<sup>11</sup>Ibid., pp. 286-288.

<sup>12</sup>S. J. Lakios. Plant Superintendent, American Smelting and Refining Co., Federated Metals Division, Sand Springs, Oklahoma, Personal Interview (May 5, 1959).

and other organics, and in the manufacture of sodium and zinc hydro-sulfite and other chemicals. Zinc dust is used in bleaching mechanical paper pulp and for metalizing paper. It is also used in metallic paints, in pipe-joint lubricants and in fireworks.<sup>13</sup>

Domestic production of zinc dust has usually fluctuated between 20,000 and 30,000 tons since 1940. These limits were exceeded in 1948 when a record high of 32,217 tons were produced and again in 1951 when production reached 31,695 tons. Average production during this period was about 26,800 tons per year. Domestic output during the past two years, 1957 and 1958, was slightly less than average, approximately 26,500 tons for each of these years. These production figures represent the total for both primary and secondary smelters. However, the latter averaged 93 percent of the total production for 1955 to 1957.

Domestic production of zinc dust from 1925 to 1957 is shown in Figure 10.<sup>14</sup>

#### Other Uses

Large quantities of zinc are processed and consumed in forms other than zinc slab and zinc dust. Zinc pigments and salts are produced directly from ores and secondary materials. Consumption of zinc for manufacture of zinc oxide, leaded zinc oxide lithopone, zinc sulfate and zinc chloride totaled 164,000 tons in 1957. These compounds were used primarily by the rubber, paint and chemical industries.<sup>15</sup>

---

<sup>13</sup>Materials Survey; Zinc, p. I-15.

<sup>14</sup>Materials Survey; Zinc, p. IV-117; Minerals Yearbooks 1951-1957.

<sup>15</sup>Minerals Yearbook 1957, pp. 1298-1299.

FIGURE 10  
DOMESTIC ZINC DUST PRODUCTION 1925-1958

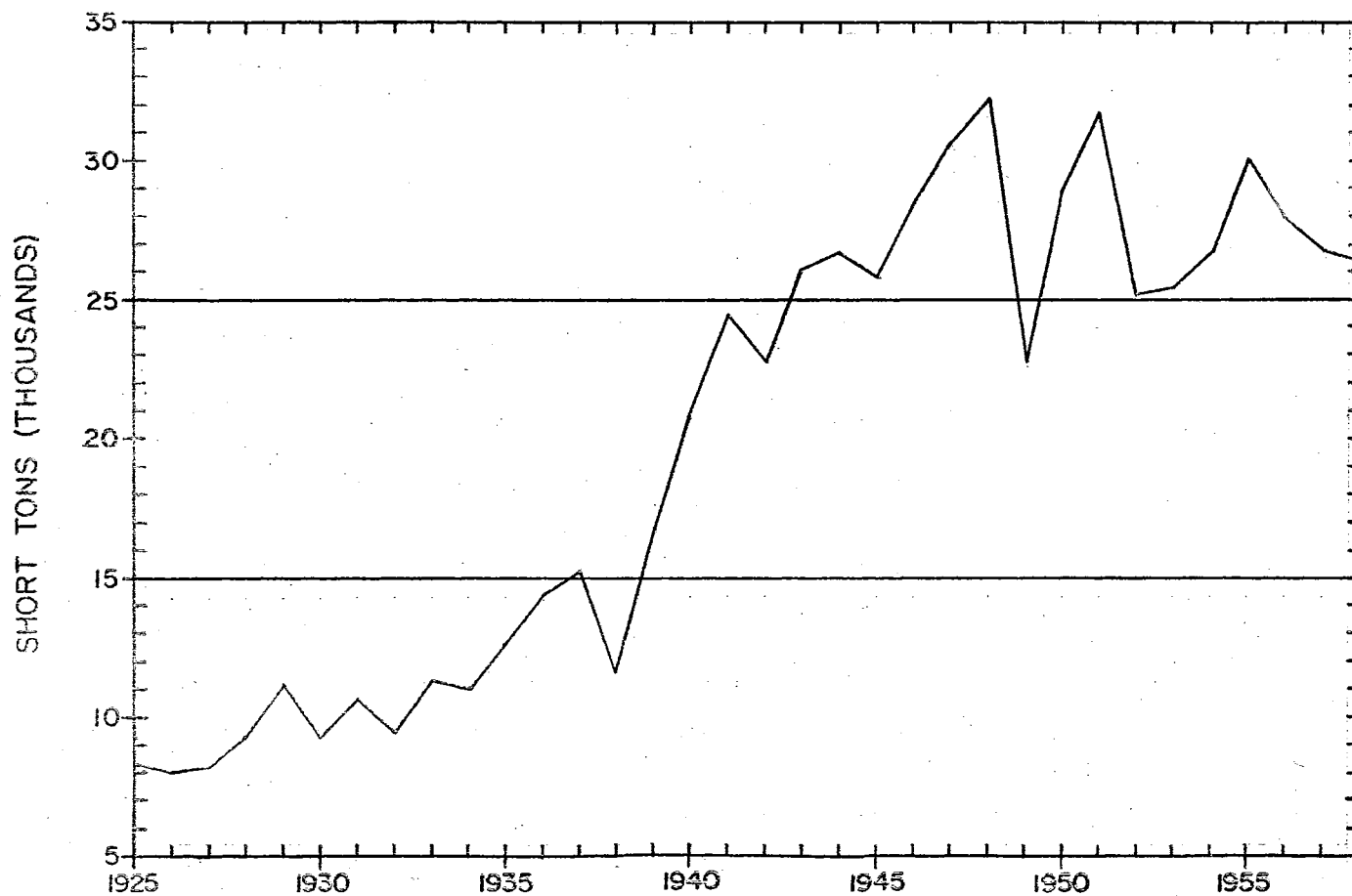

TABLE VIII  
 AVERAGE PRICE OF ZINC DUST AND PRIME WESTERN ZINC SLAB<sup>16</sup>  
 (1946 TO 1957)

Year	Zinc Slab Cents per pound	Zinc Dust Cents per pound
1946	8.7	10.6
1947	10.5	12.4
1948	13.6	15.6
1949	12.1	13.6
1950	13.9	16.6
1951	18.0	21.2
1952	16.2	19.5
1953	10.9	13.3
1954	10.7	16.3
1955	12.3	15.3
1956	13.5	16.7
1957	11.4	14.7

### Foreign Trade

#### Imports

The United States was self-sufficient in zinc for many years even though its resources were of relatively low grade. Imports were negligible from 1925 to 1936 and consisted primarily of concentrates and ores imported under bond by custom smelters for subsequent export. Zinc

<sup>16</sup>Minerals Yearbooks 1946-1957.



consumption exceeded domestic production in 1935 and imports for domestic use increased during the next four years, but the real acceleration began in 1940 when it became evident that the domestic zinc industry could not expand sufficiently to meet an industrial program based on war needs. Wartime imports reached a peak in 1943 when 539,000 tons of ore and concentrates, and 56,000 tons of zinc blocks, pigs and scrap entered the United States. Because of increased domestic needs and declining domestic reserves, the general trend since 1940 has been for larger and larger imports.<sup>17</sup>

In 1957 imports of zinc ores and concentrates for processing in domestic smelters reached to a record high of 525,730 tons. In 1954 and again in 1956 the use of imported concentrates exceeded the use of ore from domestic sources. Mexico, Canada and Peru are the primary suppliers of zinc. Imports of ores and concentrates from these countries in 1957 amounted to 469,510 tons, nearly 90 percent of the total imports. Domestic zinc slab production by source of raw material is shown in Figure 11.<sup>18</sup>

Imports of zinc slab also reached a record high of 269,034 tons in 1957. Canada was the chief source of zinc slab imports. Other important suppliers were Belgium and Luxembourg, Belgian Congo, Mexico, Peru and Italy. These countries supplied nearly 87 percent of the zinc slab imported by the United States. Figure 12 shows imports of both zinc ores and slab during 1957.<sup>19</sup>

---

<sup>17</sup>Materials Survey; Zinc, pp. IV-39-41.

<sup>18</sup>Minerals Yearbook 1957, pp. 1305-1306.

<sup>19</sup>Ibid., p. 1306.

FIGURE II

DOMESTIC ZINC SMELTER PRODUCTION BY SOURCE 1907-1957

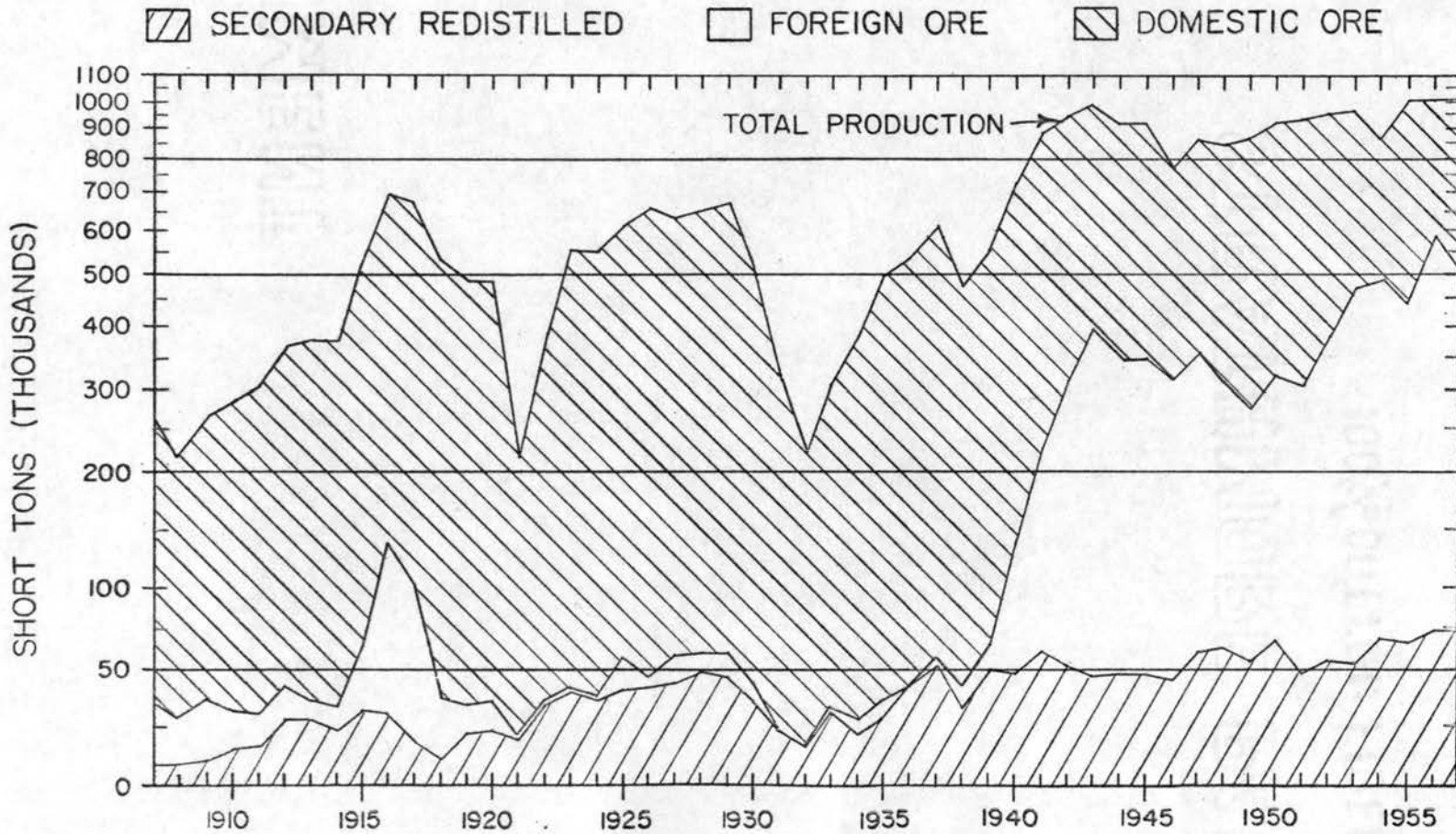
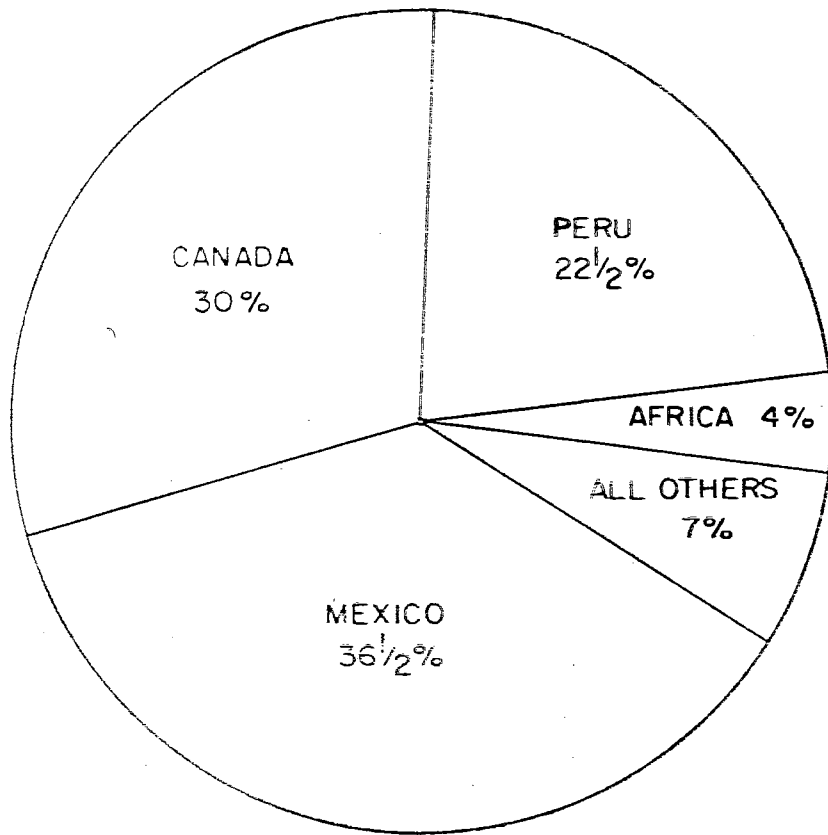
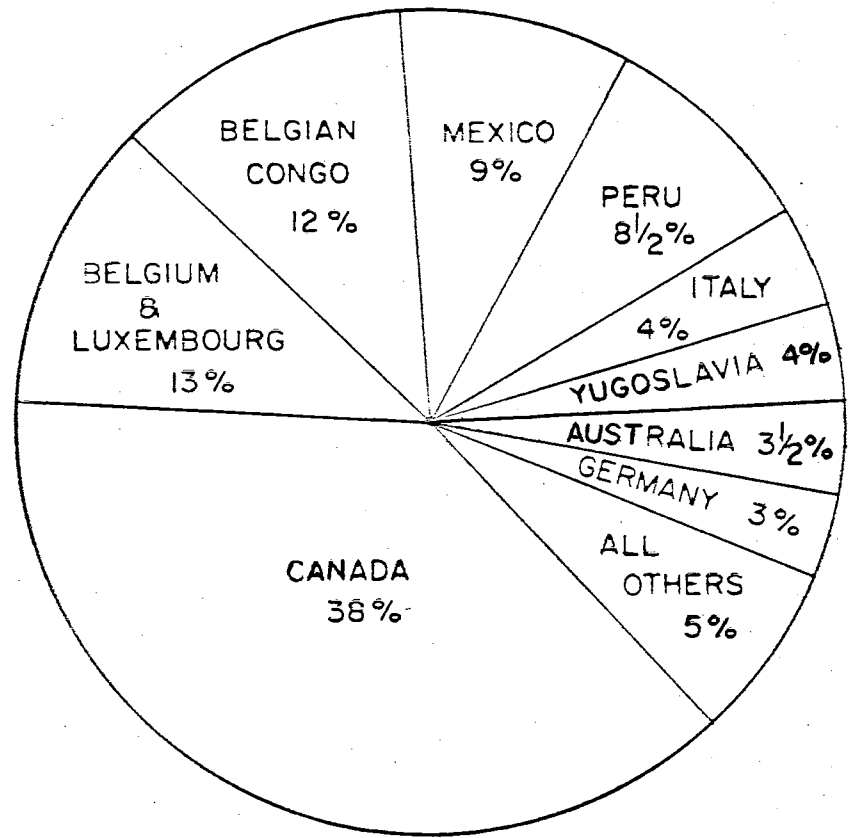

FIGURE 12  
SOURCE OF IMPORTED ZINC 1957



ZINC ORES & CONCENTRATES  
TOTAL 525,730 SHORT TONS



ZINC SLAB  
TOTAL 269,034 SHORT TONS

## Exports

The United States exported large quantities of zinc slab during World War I. Exports of zinc ores, concentrates, slab and sheet continued in lesser amounts until 1928. From 1940 to 1949 exports of zinc slab and sheet again reached substantial proportions.<sup>20</sup> In 1957 exports of zinc in ores, scrap and as a metal and dust totaled 20,900 tons. Some zinc was also exported in other forms and products such as in brass, pigments, chemicals and on galvanized steel.<sup>21</sup>

### National Policy On Zinc

National policies designed to assure adequate supplies of zinc for domestic consumption, in peace and war, are found in a large number of statutes and regulations. They provide restrictions on imports, federal grants for exploration, subsidies for American companies in foreign countries, and stockpiling adequate supplies of both zinc slab and concentrates for national emergencies.

The increasing dependence of the United States on imports of zinc slab and concentrates has already been shown. The Paley Commission reported that the objective of a national materials policy should be "to insure an adequate and dependable flow of materials at the lowest cost consistent with national security and with the welfare of friendly nations."<sup>22</sup>

---

<sup>20</sup>Materials Survey; Zinc, p. IV-62.

<sup>21</sup>Minerals Yearbook 1957, p. 1307.

<sup>22</sup>Resources for Freedom, Presidents Materials Policy Commission, Vol. I, "Foundations for Growth and Security," (Washington, 1952), p. 3.

## Tariff Policy

The primary purpose of a tariff is to encourage domestic production by providing protection against foreign competition. However, the relatively small duty imposed on imports of zinc materials has had little restrictive effect during the past 25 years.<sup>23</sup> In April, 1954, the Tariff Commission completed an investigation of the lead and zinc industry. The Commission recognized the depressed condition of the industry, but it did not recommend an increase in import duties because of the effect it would have on domestic smelters engaged in processing foreign ores.<sup>24</sup>

In May, 1954, the Tariff Commission completed its report to the President on the Escape-Clause Investigation No. 27, Lead and Zinc. This Commission recommended that the President increase the duty on imported zinc by 200 percent.<sup>25</sup> President Eisenhower rejected the recommendation explaining that the industry was suffering from the readjustment from war-stimulated levels of prices and production.<sup>26</sup>

On April 24, 1958, the Tariff Commission submitted a report on Escape-Clause Investigation No. 65 to the President. The six commissioners were unanimous in their recommendations for an increase in import duties on zinc slab and concentrates, but they were divided as to the specific

---

<sup>23</sup>Olin T. Mouzon, International Resources and National Policy (New York, 1959), pp. 439-440.

<sup>24</sup>Lead and Zinc Industries, Tariff Commission Report No. 192 (Washington, 1954), pp. 92-93.

<sup>25</sup>Lead and Zinc, Tariff Commission, Report to the President on Escape-Clause Investigation No. 27 (Washington, 1954), pp. 4, 32.

<sup>26</sup>P. W. Bidwell, Raw Materials: A Study of American Policy (New York, 1958), p. 94.

amount of the increase. They were also divided in their opinion on whether or not there should be quantitative limitations on imports.<sup>27</sup>

On September 22, 1958, the President proclaimed quantitative import restrictions on both zinc slab and concentrates. These restrictions were established on a quarterly or three-month basis with quotas as shown in Table IX and Table X. Import duties remained unchanged by this proclamation.<sup>28</sup>

### Stockpiling

Since World War II, and especially from 1950 to 1956, the national policy on raw material has been based on a program of stockpiling. During this period the government purchased vast quantities of critical or strategic materials, normally imported or in limited domestic supply, on the assumption that they would reduce or eliminate foreseeable wartime shortages.<sup>29</sup>

Following the report to the President on the Escape-Clause in 1954, President Eisenhower increased the rate of stockpiling zinc materials in lieu of increased tariffs. This form of subsidy provided some relief for the zinc industry by removing surplus supplies from commercial markets.

In October, 1957, a special committee was established by the Director of Defense Mobilization to re-examine the goals of the stockpiling program and evaluate its progress. In its report January 28, 1958, the committee

---

<sup>27</sup>Lead and Zinc, Tariff Commission, Report to the President on Escape-Clause Investigation No. 65 (Washington, 1958), pp. 2-3.

<sup>28</sup>Dwight D. Eisenhower, "Modification of Trade Agreement Concessions and Imposition of Quotas on Unmanufactured Lead and Zinc," Presidential Proclamation, Washington, D. C. (September 22, 1958).

<sup>29</sup>Bidwell, p. 38.

TABLE IX  
 IMPORT QUOTA PER THREE-MONTH PERIOD  
 FOR ZINC BLOCKS, PIGS, OR SLABS, AND ZINC DUST

Country	Short Tons
Canada	18,920
Belgium and Luxembourg	3,760
Mexico	3,160
Belgium Congo	2,720
Peru	1,880
Italy	1,880
All Others	3,040

TABLE X  
 IMPORT QUOTA PER THREE-MONTH PERIOD  
 FOR ZINC BEARING ORES OF ALL KINDS

Country	Short Tons
Mexico	35,240
Canada	33,240
Peru	17,560
All Others	8,920

denounced the use of the stockpiling program to regulate the nation's economy.<sup>30</sup>

<sup>30</sup>Ibid., p. 53.

On March 31, 1958, the authorized long-term stockpile objective was reached and the government discontinued purchases of zinc materials for this purpose.<sup>31</sup>

---

<sup>31</sup>Lead and Zinc, Investigation No. 65, p. 42.



## CHAPTER IV

### ECONOMICS OF ZINC SMELTING

The success of any industry depends to a great extent on the existence of favorable economic and technological factors. Zinc smelters constructed in Oklahoma's gas belt during the early 1900's were located with respect to these factors as they existed at that time. These same factors, although somewhat altered by time and progress, continue to affect the operation of zinc smelting activities in this area. The present location of Oklahoma's zinc smelting industry has become increasingly important in our competitive economy with its ever narrowing spread between sale price and production costs.

This chapter will be limited to a discussion of the economic character of the zinc smelting industry and to the relationship between the various locative factors and their effect on the present zinc industry in Oklahoma.

#### Locative Factors

The effect of various economic factors on the location of industry was first analyzed by Alfred Weber, a German economist, in his book, Theory of Location of Industries, published in 1909. Weber based his entire analysis of industrial location upon the economics of individual costs. "The relative price range of deposits of materials, the costs

of labor and transportation, then, are the regional factors of every industry."<sup>1</sup>

George T. Renner recognized six component elements that affected the regional location of industry. These factors are raw materials, markets, labor, power, capital and transportation. Each of these industrial ingredients influences the location of various types of industry to a different extent. To facilitate study, Renner classifies all industries into four functional types: (1) extractive, (2) reproductive, (3) faciliative, and (4) fabricative. The location of industries in each of these classes is influenced by a combination of the locational factors listed above, but in three of the four groups a single factor is dominant. This point is illustrated in Renner's laws:<sup>2</sup>

(1) "The extractive industries are, and must continue to be located by the occurrence of their raw materials."

(2) "Reproductive industries (a) which produce staple commodities are primarily localized by nature-made conditions such as climate and soil, operate under the principle of comparative advantage; (b) which produce perishable commodities tend to locate close to their markets even at the expense of greatly increased costs."

(3) "The faciliative industries tend to be located almost entirely by the distribution of markets for their services."

(4) The fabricative industries, which include zinc smelting and refining, are influenced by a combination of locative factors, each

---

<sup>1</sup>C. J. Friedrich, Alfred Weber's Theory on Location of Industries (Chicago, 1929), p. 34.

<sup>2</sup>George T. Renner, "Geography of Industrial Localization," Economic Geography, Vol. 23 (1947), pp. 167-180.

exerting a force on the industry's location. "Any manufactural industry tends to locate at a point which provides optimum access to its ingredient elements."

Ernest A. Smith, in his monograph, The Zinc Industry, discussed several factors that influenced the location of zinc smelters throughout the world, but particularly in England.

This localization of the zinc industry is due to the necessity for cheap fuel, the occurrence of good quality fireclay required for the retorts used in smelting, and to the necessity of skilled labor, whilst the climatic conditions must be suitable to the trying conditions of the workers.<sup>3</sup>

More recently Carl H. Cotterill, in his analysis of zinc smelter locations, recognized raw materials, labor and fuel as the controlling factors in smelter location. These factors are of primary importance and smelters are usually oriented toward them; however, the transportation factor has altered the effect of the primary factors in some cases. Cotterill says: "If the zinc smelter lies along the line-of-haul to market, the freight rate structure tends to nullify any advantage to be gained by choice of geographical location, from the standpoint of raw material and market locative factors."<sup>4</sup> He also recognized that other factors such as markets, adverse laws, facilities for waste disposal, taxation and technological requirements preclude the establishment of smelting activities in some locales.<sup>5</sup>

A smelter, to realize the greatest economic advantage, must be located at a point where its various raw materials can be brought together, processed and marketed at minimum cost. Moreover, the economic

---

<sup>3</sup>Ernest A. Smith, The Zinc Industry (London, 1918), p. 18.

<sup>4</sup>Carl H. Cotterill, Industrial Plant Location, Its Application to Zinc Smelting (St. Louis, 1950), p. 102.

<sup>5</sup>Ibid., pp. 4-5.

factors mentioned above not only tend to locate the industry, but they also determine whether an industry or individual plant within an industry can continue operation throughout the evolution of industrial progress and increasing competition.

#### Economic Character

Zinc smelters are characterized by their heavy investment in fixed assets in relationship to their net income. This ratio ranges up to as high as 38:1 giving a profit of less than three percent. Because of this large investment in plant facilities, the industry is extremely immobile and individual plants may continue operation even though they have lost the economic advantage they once enjoyed.<sup>6</sup>

An integrated or "captive" smelter exists primarily to supply zinc slab at the lowest possible cost to other plants within the company's organization. On the other hand, custom smelters exist primarily to process zinc ores and concentrates at a profit.

Also, part of the returns smelters receive for smelting come from the sale of metal contained in ores or concentrates that they receive over and above the content that they pay for. Thus zinc smelting may recover 91 percent, or 983 pounds, of the zinc content per ton of concentrates containing 1,080 pounds of zinc, although the smelting charge is based on 85 percent, or 918 pounds, of zinc contained. The remaining 65 pounds are part of the smelters' return for processing. The value of this 65 pounds depends, of course, on the market price of zinc.<sup>7</sup>

Zinc slab, sulfuric acid, cadmium, zinc dust and most other products of the zinc smelting industry are classified as "producers goods" because they are consumed or used by other industries rather than by the ultimate

---

<sup>6</sup>Ibid., p. 13.

<sup>7</sup>Lead and Zinc, Tariff Commission, Report to the President on Escape-Clause Investigation No. 65 (Washington, 1958), p. 48.

retail consumer. The demand for these products is classed as "derived demand" for the same reason.<sup>8</sup> Because of this fact, basic zinc products are affected by a downward trend in the business cycle earlier than industry in general and sales recovery following a period of recession is somewhat slower than normal. However, in lieu of shutting down during periods when continued operation is not economically justified, marginal producers usually maintain production at a reduced rate.<sup>9</sup>

### Zinc Smelting Costs<sup>10</sup>

Figure 13 illustrates the relative cost of the major expenses incurred during smelting and refining in relation to the value of the product. This figure also graphically compares the costs of production at a specific smelter in Oklahoma during 1957<sup>11</sup> with the average costs for all domestic zinc smelters in 1954.<sup>12</sup> As shown, raw materials are by far the largest expense, followed by labor and then fuel. Electrical power is significant on a national scale because power consumed by electrolytic refineries is included. Transportation costs are not shown separately, but are included in raw materials and fuel.

---

<sup>8</sup>E. B. Alderfer and H. E. Michl, Economics of American Industry (3d ed., New York, 1957), pp. 5-7.

<sup>9</sup>Cotterill, p. 14.

<sup>10</sup>Information contained in this section is based on averaged data provided by officials at Oklahoma's primary smelters unless otherwise cited.

<sup>11</sup>Leonard Redfield, Office Manager, Eagle-Picher Co., Henryetta, Oklahoma, Personal Interview, (June 5, 1959).

<sup>12</sup>Census of Manufactures 1954, Vol. II, "Industry," Part 2, Bureau of the Census (Washington, 1957), pp. 33B-4, 33B-7.

FIGURE 13

ZINC SMELTING AND REFINING EXPENSES

VALUE ADDED (38.7%)

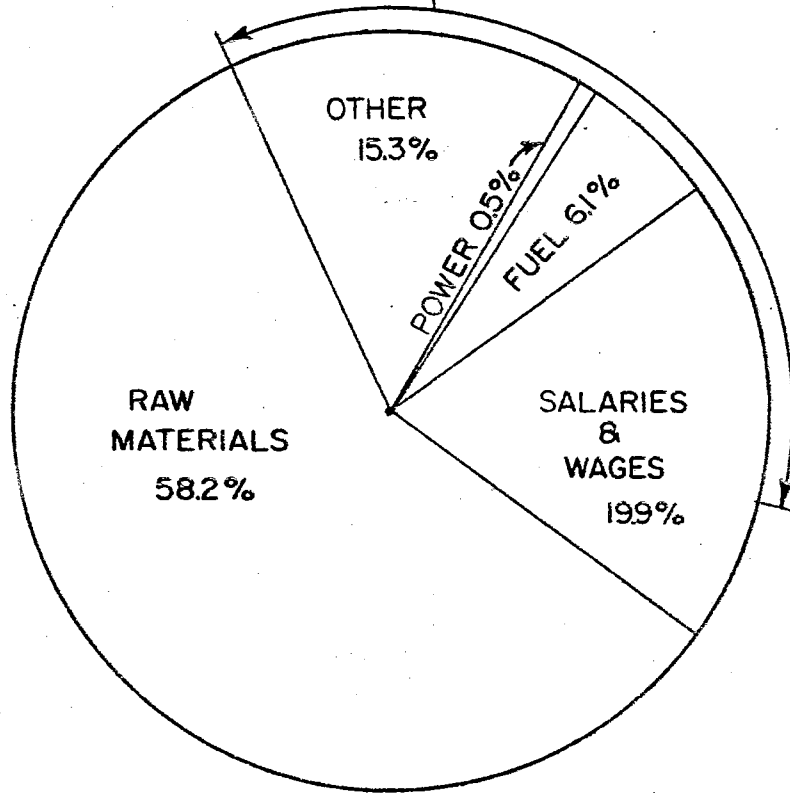

OKLAHOMA-1957

VALUE ADDED (38.0%)

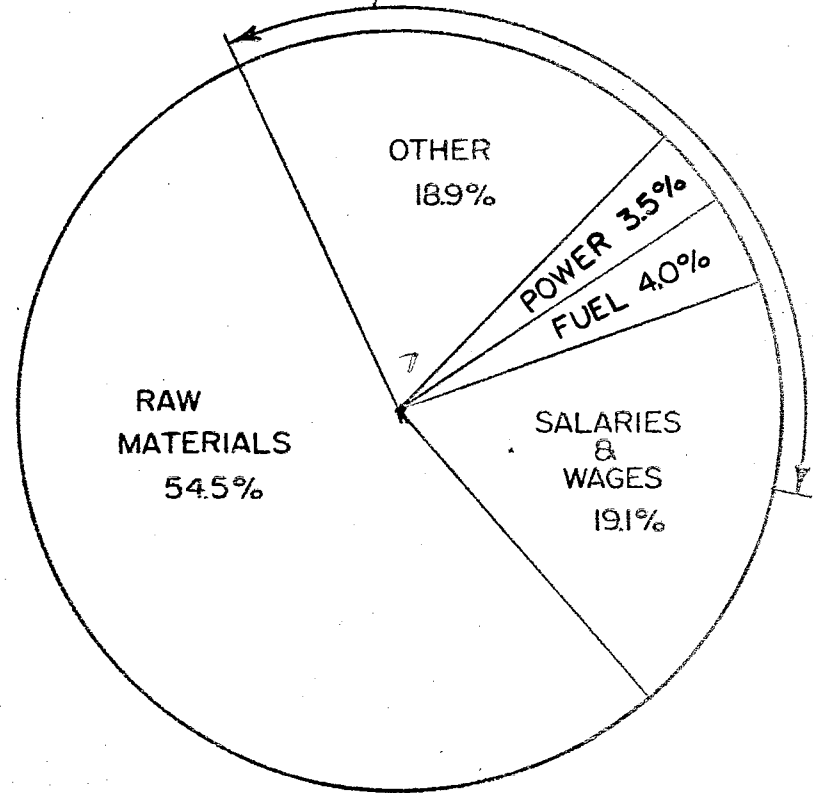

AVERAGE U.S.-1954

## Raw Materials

The primary zinc smelting industry is classified as a "high raw material cost industry" because its expenditures for raw materials (including fuel and purchased power) exceeds 60 percent of the value of products shipped.<sup>13</sup>

During the smelting operation vast quantities of raw materials are either consumer or otherwise employed in the various processes. Table XI is indicative of the bulk or weight-losing process involved at a stereo-type smelter. Consumption of raw materials in this table is based on one ton of zinc slab produced from 60 percent concentrates with 85 percent initial recovery and three percent subsequent recovery from residue processed in a Waelz kiln. These figures are based on the industry's requirements as they existed in 1947; however, since that time improved techniques have decreased the need for some materials somewhat.

TABLE XI

RAW MATERIALS REQUIRED TO PRODUCE ONE TON OF ZINC SLAB<sup>14</sup>

Raw Material	Quantity
Concentrate	3,940 lbs.
Reduction coal	1,370 lbs.
Fire Clay	346 lbs.
Chemicals	92 lbs.
Sulfuric Acid	62 lbs.
Water	5,650 gals.

<sup>13</sup>Alderfer and Mieh1, p. 12.

<sup>14</sup>Cotterill, p. 87.

As shown in Table XI, zinc concentrate is the largest single item included in raw materials. Assuming 93 percent recovery, which is about maximum for Oklahoma's smelters, nearly 1.8 tons of zinc concentrate are required for each ton of zinc slab produced. In 1957 the average cost of 60 percent Joplin concentrate was \$76.94 per ton.<sup>15</sup> Therefore, the cost of concentrate per ton of zinc slab was \$138.92. Zinc slab prices during this period averaged 11.4 cents per pound for Prime Western.

Reduction coal, so-called because it is mixed with the concentrate for charging into the retorts, for use in Oklahoma's smelters is obtained from mines located in Arkansas. The delivered price of this coal is about ten dollars per ton. The cost of coal per ton of zinc produced is about \$7.20.

Fire clay, which is used in the manufacture of retorts and condensers at each smelter, is obtained from an area near St. Louis, Missouri. The delivered price of this refractory clay is approximately the same as that for reduction coal.

The principal chemical used in the smelting process is common salt; however, during the past few years its use has decreased from about five percent as shown in Figure 13 to only one-half percent. In either case the expense of salt is insignificant when compared with that of some other components.

The sulfuric acid shown in the above figure is used by the smelters by-product section for recovery of cadmium rather than in the zinc distillation process. Only two of Oklahoma's smelters are equipped for

---

<sup>15</sup>Minerals Yearbook 1957, Part I, Bureau of Mines (Washington, 1958), p. 1304.



recovery of cadmium at present. Sulfuric acid is produced at one of these plants as an additional by-product, but the other plant must purchase acid for its use. The cost of 100 percent sulfuric acid was approximately fourteen dollars per ton in 1957.<sup>16</sup>

Water is an important raw material, especially at smelters using either cadmium or sulfuric acid by-product processes. The cost of water at a plant not processing by-products is about \$2.50 per ton of zinc slab produced. At plants with by-product operations water costs range to about \$3.50 per ton of zinc.

The raw materials discussed above are extremely important when considered together because a small percentage increase in their cost will have a pronounced effect on smelter profits. This is especially true of a "high raw materials cost industry," e.g., assuming a ten percent profit on a goods selling price, every one percent saving on raw materials means a five percent increase in profits. The following example illustrates the point:<sup>17</sup>

Selling price of goods . . .	\$1,000,000
10 percent profit . . . . .	\$100,000
Cost of materials 50 percent of selling price . .	500,000
1 percent of cost of materials . . . . .	5,000
Ratio to profit . . . . .	5 percent

---

<sup>16</sup>Ibid., p. 1298.

<sup>17</sup>W. Gerald Holmes, Plant Location (New York, 1930), p. 35.

## Labor

Horizontal retort smelters are noted for their limited use of mechanical equipment and lack of automaton in many phases of their operation. Antiquated equipment designed before some of Oklahoma's smelters were built is still in use. Mechanical charging and cleaning machines were not developed and installed until after World War II; in fact, one smelter in Oklahoma required hand charging until 1958. Mules were in common use at most plants until after 1950.

Because of their reluctance to modernize plant facilities, zinc smelters continue to have a large need for a particular type of unskilled labor. Furnace crews must be in top physical condition to perform their heavy duty labor while subjected to extreme heat, smoke and fumes. Pay for charging crews is based on an eight-hour day while actual work is on a task or piece basis. A shift normally requires from three and one-half to five hours of actual work after which the crew is free to leave.

Oklahoma's primary zinc smelters are presently classified as "medium labor cost industries" because their wage cost in relation to the value of products shipped ranges between ten and twenty percent. At the present time the cost of labor is about nineteen percent, a two percent increase since 1937. If this rate of increase continues, labor costs will exceed twenty percent within ten years and the zinc smelting industry will be reclassified to "high labor cost industry."<sup>18</sup>

In 1954 the primary zinc industry in Oklahoma employed 2,291

---

<sup>18</sup>Alderfer and Michl, pp. 11-12.

persons and had a total payroll of \$9,168,000. The average wage for production workers for this period was about \$2 per hour.<sup>19</sup>

The labor group at each of Oklahoma's primary smelters is unionized; however, the employees at each plant are affiliated with a different labor organization.

Labor-management relations seem to vary from plant to plant. One smelter reports no lost time due to labor disputes since the plant was built. Another plant reported only five days of lost time. The third plant has not been so fortunate with its labor relations. Since 1950 this plant has lost considerable time due to labor strikes.

#### Fuel and Power

During the early development of zinc smelting in Oklahoma the availability of large reserves of natural gas for fuel was the primary locative factor. Between 1906 and 1917 at least fourteen zinc smelters were constructed in Oklahoma's Gas Belt. However, as early as 1914 there was some doubt concerning the future supply of fuel for these plants.<sup>20</sup> In 1918 the world's largest horizontal retort smelter (13,440 retorts) was dismantled after only eight years of operation and moved from Collinsville, Oklahoma, because of a shortage of fuel reserves.<sup>21</sup>

At the present time Oklahoma's three primary smelters together

---

<sup>19</sup>Census of Manufacturers 1954, Vol. III, "Area Statistics," Bureau of Census (Washington, 1957), pp. 135-7.

<sup>20</sup>E. H. Leslie, "Collinsville Smelter of the Bartlesville Company," Mining and Scientific Press, Vol. 109 (August 8, 1914), p. 204.

<sup>21</sup>Mineral Resources of the United States, 1918, Part I, United States Geological Survey (Washington, 1921), p. 1042.

consume about 25 million cubic feet of gas per day at an average cost of between 18.5 and 20 cents per m.c.f. The cost for natural gas per ton of zinc slab will normally range between eight and one-half to ten dollars.

Electrical power is supplied to the primary smelters at various rates established by power companies within their areas. Oklahoma's primary smelters consume about three and one-third million k.w.h. per month. The average cost of electrical power per ton of zinc slab is about \$1.40 at one smelter; however, this rate is somewhat higher at plants producing by-products.

#### Transportation

Transportation costs can alter the effect of the other economic factors. Therefore, industry is usually drawn toward those areas which have the lowest total cost of transportation, considering both potential market areas and sources of raw materials. Moreover, the persistently rising costs of transportation are countered by an ever-increasing effort to shorten the distance between raw materials and market.

Rail transportation rates are extremely complex because they do not follow the theoretical principle of a rate proportional to distance. Instead, the rate structure is complicated by "blanket rates," "breaking points," "gateways," "processing enroute," "commodity exceptions," "long and short haul exceptions," "export and import rates," "transit privileges," freight association "territories," etc.<sup>22</sup> No analysis of the

---

<sup>22</sup>Cotterill, p. 75.

factors affecting transportation rates will be attempted here; suffice it to say that the transportation rates resulting from these factors are of considerable importance to the zinc industry.

Because of their increasing dependence on foreign concentrates, Oklahoma's smelters are particularly concerned with transportation costs. Table XIII shows the average cost of transporting ores and concentrates and zinc slab from principal foreign countries to United States destinations at rates prevailing in 1952 (in cents per pound of zinc content).<sup>23</sup>

The average cost of transporting foreign zinc ores to smelters in the United States in 1952 was 1.35 cents per pound. By comparison, the costs of transporting domestic zinc ores to the same smelters averaged 0.76 cent per pound of zinc content during the same period. Similarly, the average cost of transportation for zinc slab from foreign countries to United States consumers exceeded the average cost of transporting zinc slab from primary smelters to domestic markets. The average rate for domestic slab was 0.72 cent per pound compared with 1.18 cents for foreign zinc slab.<sup>24</sup>

Table XIII shows the average costs of transporting zinc ores and concentrates from certain foreign and domestic sources to Oklahoma's primary smelters. These figures are based on transportation rates as they existed in 1952. The costs given in this table also include insurance and handling costs.<sup>25</sup>

---

<sup>23</sup>Lead and Zinc Industries, Tariff Commission, Report No. 192 (Washington, 1954), p. 244.

<sup>24</sup>Ibid., pp. 247-248.

<sup>25</sup>Ibid., pp. 215, 217.

TABLE XII  
 COST OF TRANSPORTING ZINC FROM FOREIGN COUNTRIES  
 TO UNITED STATES MARKETS

Average cost in cents per pound of transportation, insurance, and other handling of imports shipped to--		
	:	
	United States smelters:	United States consumers
	:	
Country of origin	Zinc-bearing ores and concentrates	Slab zinc
Mexico	1.29	1.03
Canada	1.08	1.29
Peru	1.14	----
Australia	----	----
Bolivia	1.30	----
Union of South Africa	2.08	----
Yugoslavia	----	.81
Spain	1.00	----
West Germany	----	.81
Belgium	----	.87
Italy	----	.80
Philippine Republic	5.11	----
Average, all countries	1.35	1.18

The average costs of transporting zinc slab from Oklahoma's zinc smelters to domestic consuming areas in 1952 is shown in Table XIV. The costs shown in this table also include insurance and handling expenses.<sup>26</sup>

<sup>26</sup>Ibid., p. 219.

TABLE XIII

AVERAGE COSTS OF TRANSPORTATION, INSURANCE AND  
HANDLING OF ZINC CONCENTRATES FROM SOURCES TO  
DOMESTIC ZINC SMELTERS  
1952

Domestic Mining District or Country of Origin	United States Point of Entry	Destination (smelter)	Obst. per short ton
Mexico	Laredo, Texas	Blackwell, Oklahoma	\$16.88
Mexico	El Paso, Texas	Henryetta, Oklahoma	13.22
Mexico	El Paso, Texas	Bartlesville, Oklahoma	14.78
Cochise, Arizona	-----	Bartlesville, Oklahoma	13.75
Tri-State	-----	Bartlesville, Oklahoma	4.50
Tri-State	-----	Henryetta, Oklahoma	4.00

TABLE XIV

AVERAGE COSTS OF TRANSPORTATION, INSURANCE AND  
HANDLING OF ZINC SLAB FROM DOMESTIC SMELTERS TO  
CONSUMING AREAS PER SHORT TON  
1952

Destination (consuming area)	Origin (location of smelter)		
	Henryetta, Oklahoma	Bartlesville, Oklahoma	Blackwell, Oklahoma
New England	\$22.66	\$25.00	\$22.66
Middle Atlantic	20.20	21.00	20.20
South Atlantic	20.60	23.00	20.60
East North Central	16.50	17.00	16.50
East South Central	13.75	14.00	13.75
West North Central	8.25	11.00	8.24
West South Central	11.85	12.00	11.85
Pacific	23.69	24.00	23.69
Mountain	-----	-----	10.53

## CHAPTER V

### OKLAHOMA'S ZINC SMELTING PLANTS

Oklahoma's zinc smelting industry had its inception at Bartlesville in 1907 when production began at the Lanyon-Starr and Bartlesville Zinc Company's plants. The following year a third smelter was completed and began production at Bartlesville.<sup>1</sup> This third plant, owned by National Zinc Company, was the only one of these first three to survive until today.

Between 1910 and 1917 at least eleven other smelters were constructed in Oklahoma's Gas Belt. These plants were located at Quinton, Checotah, Kusa and Henryetta in the south, Sand Springs, Collinsville and Bartlesville to the north and at Blackwell in the west. Zinc slab production for Oklahoma was only about 5,000 tons in 1907. However, by 1915 production exceeded 100,000 tons and just two years later in 1917 an all-time high of 204,000 tons was produced. This rapid increase in production is shown graphically in Figure 15.<sup>2</sup>

Following World War I the demand for zinc decreased, zinc prices declined to less than five cents per pound for a short time and there was considerable doubt concerning the potential of Oklahoma's natural gas reserves. Some smelters were forced to shut down because of these factors, other plants were dismantled and moved to areas with brighter fuel

---

<sup>1</sup>Mineral Resources of the United States 1908, Part I, Geological Survey (Washington, 1910), p. 258.

<sup>2</sup>Mineral Resources of the United States 1907-1931; Minerals Yearbooks 1932-1957.





Figure 14. Aerial View of American Metal Climax, Inc.,  
Primary Zinc Smelter at Blackwell, Oklahoma.  
(Courtesy of the American Metal Climax, Inc.)

FIGURE 15  
PRIMARY ZINC SLAB PRODUCTION IN OKLAHOMA 1907-1957

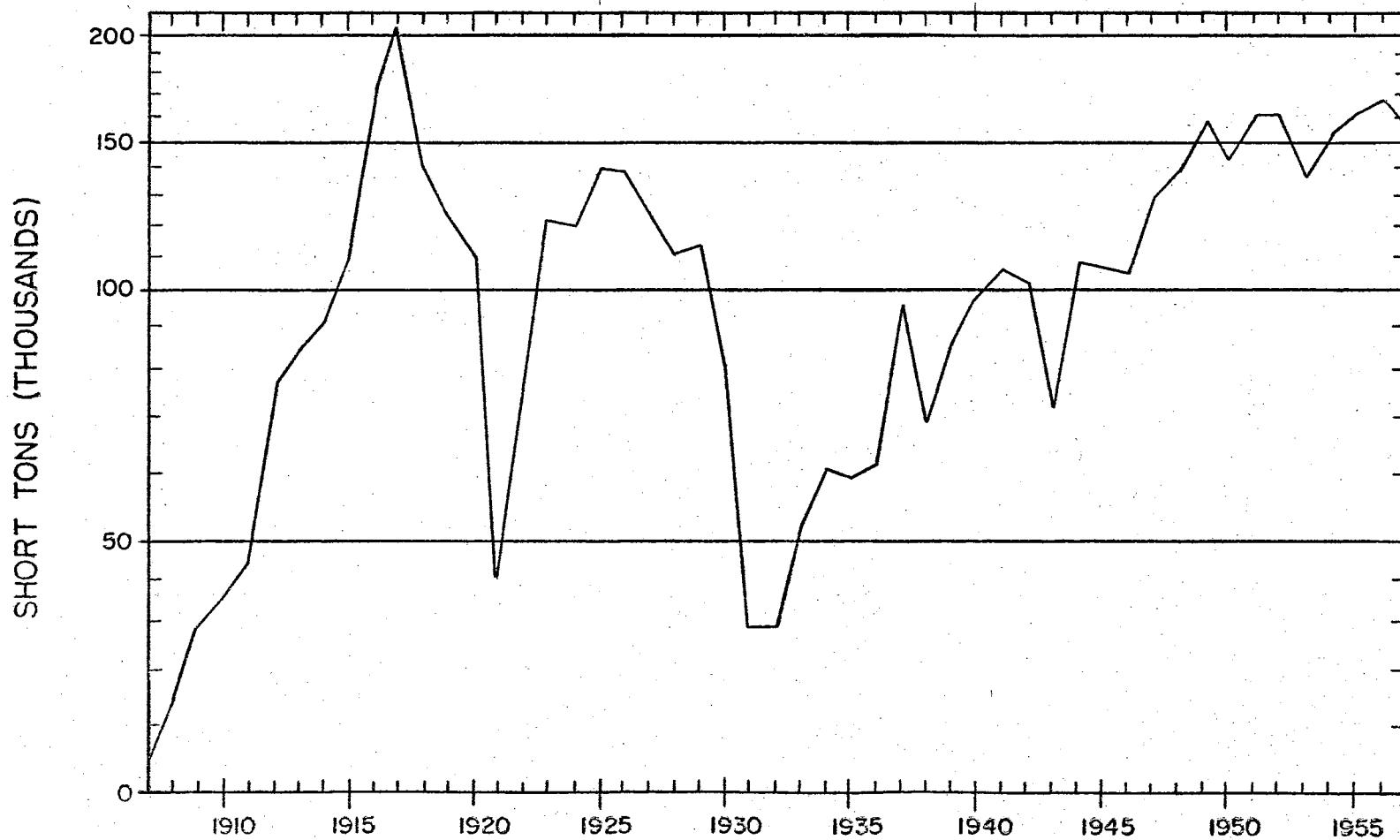

prospects.<sup>3</sup> Today only three primary smelters are in operation. One secondary plant, constructed at Sand Springs in 1922, is also in operation at the present time.

The remainder of this chapter will be devoted to a brief description of these four plants as they appear today. These plants, as shown in Figure 16, are operated by National Zinc Company, Bartlesville; Eagle-Picher Company, Henryetta; Blackwell Zinc Company, Blackwell; and American Smelting and Refining Company, Federated Metals Division, Sand Springs.

#### The Bartlesville Zinc Smelter<sup>4</sup>

The National Zinc Company, a wholly owned subsidiary of International Minerals and Metals Corporation, was incorporated in New York on March 2, 1907. Two weeks later on March 16, 1907, the newly formed company authorized construction of a zinc smelter at Bartlesville, Oklahoma. By 1908 four furnace blocks had been completed and plant operations had begun. A fifth furnace block was authorized in 1908 and the sixth and final block was authorized in 1911.<sup>5</sup>

The Bartlesville smelter is situated on a forty-acre tract of land a short distance southwest of Bartlesville. The plant is served by both the Santa Fe and the Missouri, Kansas and Texas Railroads.

---

<sup>3</sup>Ernest A. Smith, The Zinc Industry (London, 1918), p. 41.

<sup>4</sup>Information contained in this section is based on material obtained by personal observation and from J. S. Van Aken, Smelter Superintendent during a conducted tour of the Bartlesville smelter (June 9, 1959) unless otherwise cited.

<sup>5</sup>Margaret Grant, "National Zinc Co. to Observe Golden Anniversary," The Bartlesville (Okla.) Examiner-Enterprise (Bartlesville, October 10, 1957), p. 2.

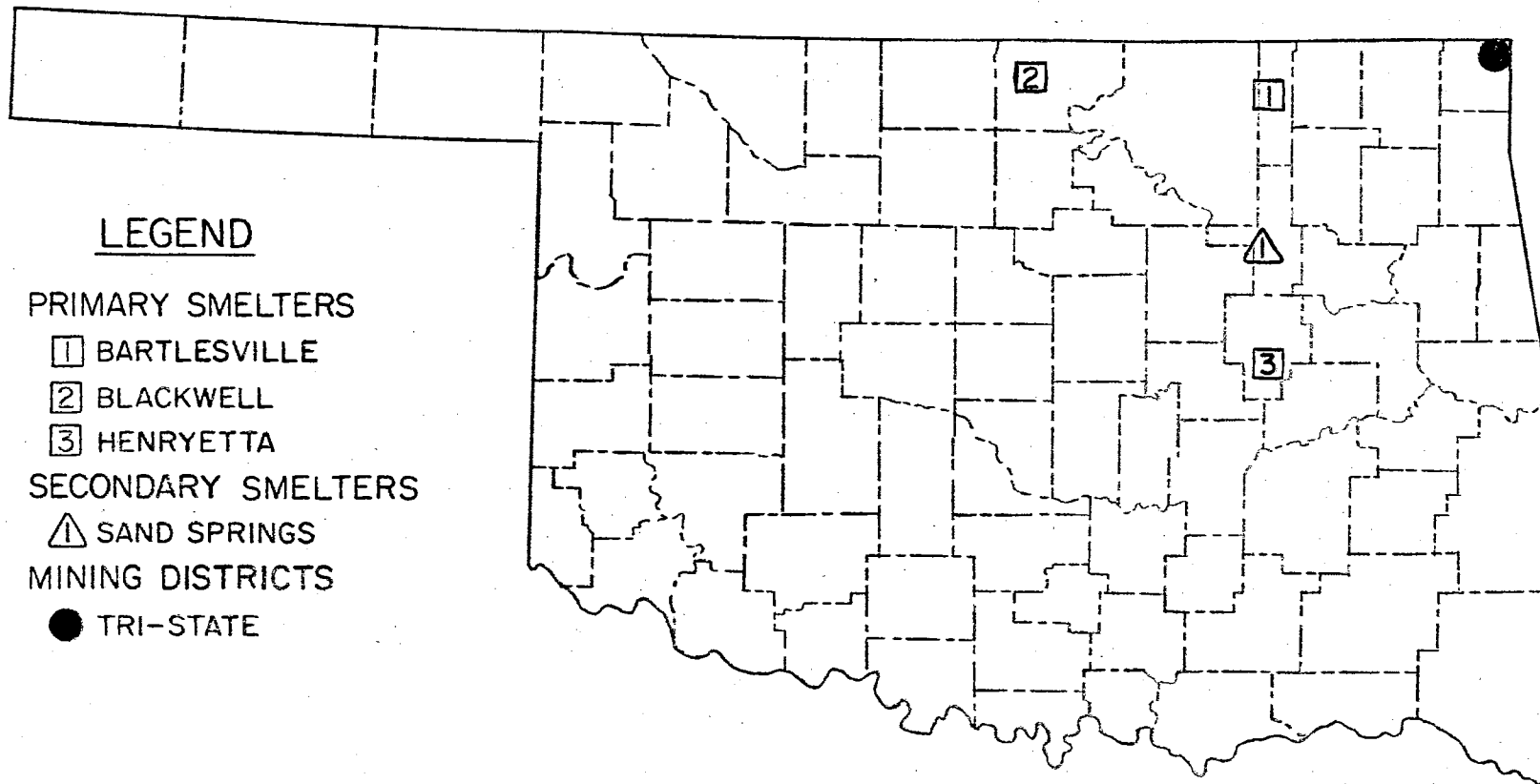

LOCATION OF ZINC MINES AND SMELTERS

FIGURE 16

## Processes

The processes employed at the Bartlesville Smelter are quite similar to those discussed in Chapter II. These processes will be discussed briefly here in conjunction with the particular facilities at this plant.

Handling and storage of "green ore" and concentrates are essentially the same at all plants. At Bartlesville the green ore is dumped from gondola cars, or unloaded by means of an overhead crane into segregated bins or piles. Ores are chemically analyzed to determine their exact mineral composition. Later, various ores are combined to produce a concentrate with the desired qualities. This is common practice; however, not all ores require mixing prior to roasting.

In 1953 the old type multiple-hearth roasters at Bartlesville were replaced with two Fluo Solids fluid-bed reactors. The most modern of roasting processes. Each of these two reactors has a rated capacity of 100 tons per day. Sulfur dioxide contained in roaster gases is recovered and used to produce sulfuric acid.

This smelter has three standard Dwight Lloyd sintering machines. Two of these have conveyors measuring 42 inches across and are rated at 70 tons per day. The third sintering machine has a 60-inch bed and a daily capacity of 120 tons. Volatile compounds of lead and cadmium are recovered as dust from the gases produced during the sintering process by an electrostatic precipitator. The dust which contains these compounds is later treated to recover these metals.

The clinker produced by the sintering machine is crushed, sized and then conveyed to the mix room where it is combined with other materials in a huge mixer. After mixing the charge is either stored or transported

by a one-ton monorail hoist to the furnace blocks for charging into the retorts.

The Bartlesville smelter has six furnace blocks with 832 retorts per block. Charging is accomplished by an auger-fed, multiple-retort, charging machine. This plant operates on a standard 48-hour cycle with five draws scheduled during each cycle. The molten zinc recovered during this process is cast into 57-pound slabs and either moved to the storage area for shipment or sent to the liquator building where the slab is remelted and combined with other zinc slab to produce a uniform grade or combined with other materials to comply with customer specifications.

After the last draw, the condensers are taken down and a cleaning machine removes all slag and residue from the retorts. Broken condensers and retorts, which are made of pottery, must be replaced before the furnace is ready to begin another cycle.

Each horizontal retort smelter has its own pottery unit where retorts and condensers are manufactured. Because of the short life of the retorts, usually about 40 days, and the extremely short life of condensers, often less than a week, they must be mass produced in large quantities.<sup>6</sup> The exact composition of the carefully blended materials used for making these products varies at each plant; however, those used at Bartlesville are typical of most horizontal retort smelters.

Retorts are made of 50 percent refractory clay, 25 percent calcine clay and 25 percent silica flour mixed with a little water and fed into a pug mill. After preliminary pugging the clay, or "mud" as it is called, is stored in rotting rooms where it ages until ready for use. After aging

---

<sup>6</sup>Dale McCall, Safety Director, Eagle-Picher Co., Henryetta, Oklahoma, Personal Interview (June 5, 1959).

the mud is repugged, then placed in a retort machine and extruded at a pressure of 3000 pounds per square inch. Condensers are made of 38 percent refractory clay and 62 percent broken retorts and are formed by a rotating plunger. The capacity of the retort press is about 250 per day and the condenser machine is capable of producing about 180 per hour.

After the retorts and condensers are formed they must be dried and then fired. The Bartlesville plant has twelve drying rooms, each having a capacity of 800 retorts. Drying time for retorts ranges between 40 and 60 days. Condensers require less time to dry because of their relatively small size. Both retorts and condensers must be fired in specially designed kilns. In addition, retorts must be preheated before being placed into furnace blocks. This step is not necessary with condensers.<sup>7</sup>

#### Raw Materials

Since National Zinc has no captive source of raw materials, all zinc ore and concentrate must be purchased on the world market. At the present time about 90 percent of the green ore processed at the Bartlesville smelter is imported from foreign sources. Major suppliers include Mexico and Canada, Chile, Peru and Bolivia in South America, Sweden, Spain, Germany and Yugoslavia in Europe, Australia and Tasmania. Domestic ores are obtained principally from Utah and Arizona.

Imported concentrates used by the Bartlesville plant normally enter the United States at either New Orleans, Louisiana or Houston, Texas. These concentrates usually average about 53 percent zinc.

---

<sup>7</sup>"National Zinc Company is Pioneer Industry of Bartlesville," The Bartlesville (Okla.) Examiner-Enterprise (Bartlesville, October 10, 1957), p. 4.

## Labor

Total employment at the Bartlesville smelter exceeded 600 in 1957; however, since that time the plant's working force has been trimmed to about 500 men. This reduction in force has resulted chiefly from discontinuing some operations and mechanizing others. This decrease in workers has not been accompanied by a decrease in production.

Employees of the National Zinc Company, Inc., are represented by the Oil, Chemical, and Atomic Workers International Union, Local 5-401, A.F.L. - C.I.O. The present Union contract is effective until May 31, 1960.

Labor Relations at this plant have been good. In recent years only five days have been lost because of strikes. These five days were lost during two strikes in 1958; one strike lasting four days and the other just one day.

At the present time the average wage for production workers is about \$2.22 per hour. The total annual labor cost is approximately 2.5 million dollars.

## Fuel, Power and Coal

Natural gas is supplied to the Bartlesville plant from both the Smelter Gas Company, a subsidiary of National Zinc Company, and from Cities Service Gas Company. At the present time each gas company provides about 50 percent of the smelter's needs. Consumption of natural gas at present is about five million cubic feet per day at an average cost of 20 cents per m.c.f.

Electrical power is purchased from the Public Service Company of



Oklahoma. The plant normally consumes 1,310,000 k.w.h. per month with an approximate cost of \$1,300 per month.

Reduction coal is supplied by mines in Arkansas at about ten dollars per ton. The plant consumes about 2,200 tons per month.

#### Products and Markets

Zinc slab production at the Bartlesville smelter averaged over 40,000 tons from 1955 through 1958. By-products are particularly important at this plant. The annual production of sulfuric acid is about 50,000 tons, cadmium is approximately 730,000 pounds per year, zinc dust production exceeds 10,000 tons annually and nearly 50,000 pounds of mercury are recovered each year.

Zinc slab produced at Bartlesville is used primarily by the galvanizing industry. Galvanizers in the Great Lakes region consume about 60 percent of this plant's total production. Other important consumers are located throughout the Midwest and in Alabama.

Sulfuric acid markets are located in Oklahoma, Kansas, Missouri and Texas; however, most consumers are located within a 300-mile radius of the Bartlesville smelter.

#### The Blackwell Zinc Smelter<sup>8</sup>

The Blackwell zinc smelter was built on a site just west of Blackwell, Oklahoma, in 1915 by the Bartlesville Zinc Company. Production began the following year after twelve furnace blocks with 9600 retorts had

---

<sup>8</sup>Information contained in this section is based on material obtained by personal observation and from James M. Fraiser, Office Manager, and Bill Chaney, Engineering Department, during a conducted tour of the Blackwell smelter (June 3, 1959) unless otherwise cited.

been completed.<sup>9</sup> In 1922 this smelter was purchased by the Blackwell Zinc Company, a 100 percent subsidiary of American Metal Company, Ltd.

Today the Blackwell plant has fourteen furnace blocks containing 11,200 retorts with an annual capacity of nearly 100,000 tons of zinc slab. Annual production at this plant has exceeded 75,000 tons for the past ten years. In 1958 the plant operated at 80 percent capacity, producing 77,000 tons of zinc slab, about nine percent of the total domestic output.<sup>10</sup> At the present time the Blackwell plant is operating at 72 percent capacity with 8,000 retorts in use.

#### The Parent Company<sup>11</sup>

The American Metal Company was incorporated in New York in 1887. Its present name, American Metal Climax, Inc., was adopted in 1957 when it merged with the Climax Molybdenum Company.

The parent company acts as a centralized agency, controlling all purchases and sales of ore, concentrates, other raw materials and refined products from its New York offices. Subsidiary companies carry on all mining, smelting and refining operations. Company smelters process materials produced within the organization or purchased on the world market. Custom smelting is also done on a toll basis for other companies.

American Metals Climax, Inc., is both a holding and operating company. Sales and services in 1957 and 1958 exceeded one-half billion

---

<sup>9</sup>Mineral Resources of the United States 1916, p. 820.

<sup>10</sup>American Metals Climax, Inc., Annual Report for 1958 (New York, 1959), pp. 17-18.

<sup>11</sup>John Sherman Porter, ed., Moody's Industrial Manual 1957 (New York, 1957), pp. 2756-2757.

dollars. The principal products, gold, silver, copper, lead and zinc, are produced principally in the United States, Mexico and Northern Rhodesia.

### Processes and Products

The processes utilized at the Blackwell plant are similar to those used at most horizontal retort smelters with two major exceptions. First, the roasting and sintering steps have been combined; and second, a distillation process for refining High Grade and Special High Grade zinc has been developed and is in limited production.

In 1951 a huge sintering machine, built by the Ore Reclamation Company, was installed at the Blackwell plant. The bed of this machine is 12 feet by 168 feet and it has a capacity of 540 tons per day. This machine is significant because of its tremendous size and capacity; but even more important is its ability to accomplish both roasting and sintering in a single operation.

Gases and dust produced during the sintering process are collected and filtered through orlon bags to recover all metallic compounds. After filtering the waste gases, including sulfur dioxide, are released into the atmosphere through a high stack.

The principal product of the Blackwell smelter is Prime Western zinc slab; however, since January, 1959, a limited amount of Special High Grade has been produced by the plant's new distillation refinery. Special die cast metals are also produced by alloying Special High Grade with other metals.

Cadmium is the only by-product produced at the Blackwell plant on a large scale basis. The cadmium recovery facilities are relatively new with production beginning in 1957. Production during the first year of

operation was about 750,000 pounds and the following year, 1958, production increased to 1,500,000 pounds.<sup>12</sup>

#### Raw Materials

Zinc concentrates processed at the Blackwell plant are obtained entirely from foreign sources. At the present time Mexico supplies 85 percent and Africa supplies 15 percent. The zinc content of these concentrates normally ranges between 57 and 58 percent.

The following information on consumption and costs of raw materials is based on the smelter operating at about 72 percent capacity.

Natural gas is supplied by pipeline from Texas fields. The present rate of consumption is about 10,000,000 cubic feet per day and the annual cost of natural gas is \$750,000.

Reduction coal is obtained from Arkansas at a cost of \$360,000 per year. At present the plant consumes about 100 tons per day.

Electrical power and water are purchased from the city of Blackwell. Nearly 57,000 k.w.h. of electrical power is used daily. The annual cost of power is \$146,000. The plant uses about 43,000 cubic feet of water per day costing over \$22,000 per year.

#### Labor

In February, 1958, the Blackwell Smelter cut back production to its present level of about 72 percent capacity. The reduction in labor force which followed the cut-back reduced the total number of employees from 900 to 780.

---

<sup>12</sup>American Metals Climax, Inc., Annual Report, 1958, p. 18.

Production workers earn an average of \$2.20 per hour and fringe benefits amount to \$4.65 per day. The total labor cost for 1958 was nearly \$3,750,000.

Employees of the Blackwell smelter are affiliated with the American Federation of Smelter Workers, Local No. 21538. Labor-management relations are and have been excellent. The plant has had no lost time due to strikes since it was built in 1915.

### The Henryetta Zinc Smelter<sup>13</sup>

In 1916 several new horizontal retort zinc smelters began production in Oklahoma. One of these plants was constructed by the Picher Lead Company on a 40-acre tract of land located one and one-half miles north-east of Henryetta, Oklahoma. When production began, the plant had furnaces for 4,000 retorts. Today, the smelter site occupies 51 acres and has furnaces for 8,800 retorts.

### The Parent Company

On January 10, 1867, the Eagle White Lead Company was incorporated in New York. On June 1, 1916, it merged with the Picher Lead Company and its name was changed to Eagle-Picher Lead Company. In 1945 the present name, Eagle-Picher, was adopted.<sup>14</sup>

Eagle-Picher is presently engaged in mining, smelting, manufacture and distribution of lead and zinc products and in the manufacture and

---

<sup>13</sup>Information contained in this section was obtained by personal observation and from Leonard Redfield, Office Manager, during a conducted tour of the Henryetta smelter (June 5, 1959), unless otherwise cited.

<sup>14</sup>John Feen, "Salute to Eagle-Picher Company," Miami Daily News-Record (Miami, August 19, 1956), pp. 1-2.

distribution of pigments, oxides, rubber products, insulation, waxed paper and cellophane wrappers, plastic products and ceramics. Net sales for Eagle-Picher have averaged about 106 million dollars per year since 1955.<sup>15</sup>

#### Processes<sup>16</sup>

The processes employed at the Henryetta smelter are similar to those described in the metallurgical section of this report. However, in recent years some activities at the Henryetta plant have been replaced by similar facilities located elsewhere.

In 1954 Eagle-Picher completed a new plant at Galena, Kansas, which was designed to perform several processes involving zinc ores and concentrates. Some of these processes were usually considered part of the smelting operation and were normally located at the smelter site. The new Galena plant included a roasting and sintering section along with facilities for recovering sulfuric acid and cadmium. In 1955 these processes were discontinued at the Henryetta smelter.

The Henryetta smelter has 8,000 retorts with a capacity of 150 tons per day available for production, but at the present time only 4,800 retorts are in use and plant capacity is reduced to 60 percent, 90 tons per day.

The standard 48-hour cycle with five scheduled drawings is used at the Henryetta plant. Zinc recovery averages between 92 and 93 percent. After the zinc slabs are cast and cooled they are removed from the mold

---

<sup>15</sup>Eagle-Picher Company Annual Report for 1958 (Cincinnati, 1959), pp. 11-12.

<sup>16</sup>McCall, Personal Interview (June 5, 1959).

and packaged for shipment or sent to the equalizer department where they are remelted and combined to produce zinc of standard quality or to meet customer specifications. Furnace residue is collected and removed to the Waelz kiln for further processing and recovery of zinc oxide.

#### Raw Material

Eagle-Picher has expanded its use of imported zinc ores and concentrates because of current domestic mining conditions. Ores from several foreign sources including Canada, Mexico, Peru and Australia are being processed at the present time. These imported materials are combined with concentrates from domestic mines, roasted and sintered and then shipped by the Galena plant to Henryetta ready for mixing.

Some rather low-grade concentrate is shipped directly from Mexico to Henryetta for processing in the Waelz kiln and subsequent use along with zinc oxide recovered from the usual furnace residues.

#### Labor

Prior to 1955 employment at the Henryetta smelter ranged between 700 and 800. In the latter part of 1955 the roasting and sintering operations were discontinued at Henryetta and the cadmium plant, which depended on sinter and roaster gases for its raw material, was also closed down. This eliminated the need for several workers and a reduction in force followed.

In February, 1958, the Henryetta smelter was shut down because of lowering zinc prices and increasing inventories. Production resumed in December, 1958, but at a reduced rate. During the shutdown mechanical charging and cleaning machines were installed. This further reduced the number of workers needed on furnace crews.

At the present time the Henryetta smelter employs about 525 men including management. Assuming plant operations continue on the present scale, the size of labor force should remain fairly constant at about the present number.

Employees at the Henryetta plant are affiliated with the United Steel Workers of America, Local Union 4327, A.F.L. - C.I.O. Labor disputes between Union and management have occurred several times and considerable time has been lost because of strikes against the company. The plant was strike-bound 67 days in 1950 and in 1957 the smelter was shut down from July to October because of a labor dispute.

Following the 1957 strike, a three-year contract was signed which included provisions for a union shop, health and accident insurance and life insurance provided by the company, specific wage rates and work limits for all labor classifications, an annual five cent per hour increase scheduled through July 1, 1959, and provisions for pay increases based on the cost of living index.

The standard five-day, forty-hour work week is recognized for pay purposes; however, most production workers can complete their scheduled work in three and one-half to four hours. The average wage at the present time is \$2.13 per hour and no further wage increases are scheduled in the present labor contract.

#### Fuel, Power, and Water

The Henryetta smelter site was selected primarily because of large reserves of natural gas located nearby. When smelter production began in 1916 natural gas sold for four cents per thousand cubic feet. In 1919 Eagle-Picher developed a field of its own at Turkey Pan Hollow because of the sharply increasing gas prices. Today, the major portion of gas



consumed is purchased from Oklahoma Natural Gas Company with the remainder furnished by company-owned wells.<sup>17</sup>

The present consumption rate is about 9,000,000 cubic feet per day. The cost of purchased gas is 18.5 cents per thousand feet but by using gas from company-owned wells the average cost of gas used is reduced to 16 cents per thousand cubic feet.

Coal, which is mixed with sinter for charging into the retorts, is supplied by Arkansas mines. The present consumption rate is 2,000 tons per month at a cost of \$9.75 per ton delivered. Coke consumption has been insignificant since the roasting and sintering operations were discontinued.

Electrical power is supplied to the smelter by the Public Service Company of Oklahoma. Power consumption at the present rate of production averages about 350,000 k.w.h. per month at an average cost of approximately \$4,000 for this period.

Smelter operations require nearly 7,000,000 gallons of water per month. Water is purchased from the City of Henryetta at an average cost of \$1,100 per month.

#### Products and Markets

The primary product of the Henryetta smelter is Prime Western zinc slab. However, some zinc is blended or alloyed in the equalizing furnace to produce custom zinc according to customers' specifications.

Zinc produced at Henryetta is usually consumed by the galvanizing

---

<sup>17</sup>"Henryettan Recalls Day He Came Here to Give Life to Eagle-Picher Zinc Smelter," Henryetta Daily Free-Lance (Henryetta, April 25, 1951), p. 10.

industry located throughout the Midwest. At the present time galvanizers in the Illinois-Indiana-Ohio region use about 50 percent of Henryetta's output.

Zinc slab production has varied considerably at the Henryetta plant during the past five years because of labor and economic problems. Production for these years was:

1954	. . . . .	37,750 tons
1955	. . . . .	44,500 tons
1956	. . . . .	1,300 tons
1957	. . . . .	2,900 tons
1958	. . . . .	9,250 tons

#### By-Products

The only by-product presently recovered at the Henryetta smelter is a germanium concentrate which is processed by Eagle-Picher at Miami, Oklahoma.

#### The Sand Springs Secondary Smelter

The Sand Springs plant of the American Smelting and Refining Company, Federated Metals Division, occupies an area of 32 acres located a short distance southwest of Sand Springs, Oklahoma. The plant is served by the Sand Springs Railroad Company which has connections with several major rail carriers at Tulsa.<sup>18</sup>

---

<sup>18</sup>S. J. Lakios, Plant Superintendent, American Smelting and Refining Company, Federated Metals Division, Sand Springs, Oklahoma, Personal Interview (May 5, 1959, and June 5, 1959).

## The Parent Company

The American Smelting and Refining Company was incorporated in New Jersey in 1899 as a consolidation of a number of mines, smelters and refineries. Today ASARCO is both a holding and operating company with subsidiaries located throughout the United States, Mexico and Canada. Extensive operations are also carried on in Bolivia, Peru and Chile in South America and in Australia and England. The company is primarily engaged in custom smelting and refining of non-ferrous metals. In addition the company and its subsidiaries are engaged in mining and milling operations at various owned, leased or managed properties. Custom smelting is also done for other companies on a toll basis. Other company interests include: recovery of non-ferrous scrap and secondary materials, the recovery and sale of by-products from all its operations, the mining of coal and coke production primarily for company use, and the limited manufacture, fabrication and sale of non-ferrous metal products.<sup>19</sup>

ASARCO has 26 smelters and refineries that produce primary copper, lead and zinc. In addition, the Federated Metals Division of ASARCO has 12 plants that are mainly engaged in secondary metals production. The Sand Springs Plant and a similar smelter located at Trenton, New Jersey, are the only two of this group that produce zinc dust as a primary product; however, zinc dust is produced as a secondary or by-product at several ASARCO plants.<sup>20</sup>

The tremendous operation carried on by ASARCO and its subsidiaries

---

<sup>19</sup>John Sherman Porter, ed., Moody's Industrial Manual, 1957 (New York, 1957), p. 2779.

<sup>20</sup>Ibid., p. 2780.

is shown in the company's financial statement. In 1957 the sale of services and products approached one-half billion dollars and in the recession year of 1958 these sales exceeded one-third billion dollars.<sup>21</sup>

### The Sand Springs Smelter

In 1914 the United States Zinc Company purchased a partially completed primary smelter at Sand Springs, Oklahoma. A total of 2,400 retorts were completed and in production by the end of 1914 and 1,600 more retorts were under construction. By the end of 1916 a total of 8,000 retorts were available for production.<sup>22</sup>

Following World War I many primary smelters were forced to shut down because of the excess capacity developed to meet war production requirements. In 1922 the United States Zinc Company dismantled its primary zinc smelter at Sand Springs, Oklahoma, and shipped part of it to Amarillo, Texas, and the rest to Rosita, Mexico. While the primary plant was being dismantled, graphite retort furnaces suitable for secondary zinc distillation were constructed and placed in production.<sup>23</sup>

### The Product and Its Market

In the normal horizontal retort smelting process between three and ten percent of the zinc reduced is in the form of zinc dust. Usually this dust was recharged back into the retorts for conversion to slab zinc, but in 1910 the United States Zinc Company, a 100 percent owned

---

<sup>21</sup>American Smelting and Refining Company 60th Annual Report 1958 (New York, 1959), p. 22.

<sup>22</sup>Mineral Resources of the United States 1916, pp. 817-820.

<sup>23</sup>S. J. Lakios, Personal Interview (May 5, 1959).

subsidiary of ASARCO, began preparing the zinc dust produced at its Pueblo, Colorado, plant for the commercial market. Other smelters in this country were not in position to compete with imported zinc dust at this time. Furthermore, it was to their advantage to convert all zinc dust they produced into slab because the latter was protected by a tariff of one and one-half cents per pound and zinc dust was not. In 1915, when zinc dust normally imported from Belgium and Germany was no longer available, many other companies followed ASARCO's lead.<sup>24</sup>

The physical properties of zinc dust are somewhat different from those of zinc slab; i.e., more rapid oxidation, absorption of hydrogen and generally greater chemical reactivity as a chemical reducing agent because of the increased surface area. These peculiar properties of zinc dust account for its demand and uses.<sup>25</sup>

The zinc dust produced at this plant is utilized by various industries in this country and abroad. Plant capacity and production figures were not available, but the value added can be estimated at about 50 percent by comparing the cost of zinc scrap, which is used for raw material, with the price of the finished product.

Zinc dust is classified as "producers' goods" because it primarily serves other industries rather than the ultimate consumer. Its demand is classed as a "derived demand" for the same reason. Since moderate changes in zinc dust's price will either improve or injure its competitive position among other materials, it is also said to have an "elastic demand."<sup>26</sup>

---

<sup>24</sup>Mineral Resources of the United States, 1914, p. 871.

<sup>25</sup>Ibid., pp. 871-872.

<sup>26</sup>B. E. Alderfer and M. E. Michl, Economics of American Industry (3d ed., New York, 1957), pp. 5-7.

### Economic Factors

All secondary smelters utilize scrap metals as their principal raw material. Production in the Sand Springs plant is derived mainly from galvanizing dross which normally contains a minimum of 92 percent zinc, three and one-half percent iron and one percent lead, plus small amounts of other metals.

Raw materials are purchased at prevailing zinc scrap market prices f.o.b. East St. Louis, Illinois. Transportation costs, therefore, become very important factors and only galvanizers located in areas near enough to prevent excessive freight charges can serve this plant. These areas include: Colorado, Illinois, Texas, Alabama and others.<sup>27</sup>

According to the management of the Sand Springs plant, the cost of raw materials is by far the greatest expense incurred in their operation. Although specific information is not available, this plant can probably be classified as a "high raw material cost industry."<sup>28</sup>

### Fuel

The original primary zinc smelter was constructed at Sand Springs in 1914 because of two important factors. First, a possible smelter site was surveyed, improved and advertised by an enterprising promoter. Second, the site was located within Oklahoma's natural gas belt which could provide large quantities of fuel at low cost.

Today's secondary smelter does not consume such large quantities of fuel as did its predecessor, but it does enjoy the same relatively

---

<sup>27</sup>S. J. Lakios, Personal Interview (May 5, 1959).

<sup>28</sup>Alderfer and Michl, p. 12.

low cost of natural gas. Although no specific information concerning the quantity of fuel consumed or its cost was available, the management emphatically stated that the Sand Springs plant could heat its furnaces at a cost far below that required to heat those of a similar plant located in New Jersey which utilizes a different type of fuel.<sup>29</sup>

#### Labor

One of the striking features noted at this plant was an apparent spirit of cooperation and good will between labor and management. Although these workers are not affiliated with any labor union, they seem to enjoy working conditions, pay and fringe benefits equal to if not better than average for this area.

This smelter employs 35 people including management. Pay for production workers averages \$1.91 per hour with time and one-half for all over 40 hours and double time and one-half for work on holidays. Paid holidays include the customary six calendar holidays plus the employee's birthday. Fringe benefits amount to \$50 per employee per month. These benefits include insurance and retirement.

Protective clothing, shoes, goggles and masks are required for certain tasks around the furnaces and screening machines; however, safety procedures are stressed in all phases of the plant's operations.

Facilities for the employees' personal use are housed in a small but adequate building located adjacent to the main working areas. This building serves as a combination locker room, rest room and shower, and as a time office and lunch room. A rather unique feature has been

---

<sup>29</sup>S. J. Lakios, Personal Interview (May 5, 1959).

installed in the locker room area. Each employee has a large floor locker which is partitioned to separate his work clothes from his street clothes. These lockers are air-conditioned to remove moisture and odor from clothes placed in them.

The Sand Springs plant is classified as a "low labor cost industry." This classification is based on an estimated labor cost in percentage of the value of products shipped which is less than 10 percent in this case.<sup>30</sup>

#### Transportation

Transportation costs limit the area served by an industry and this factor also limits the area from which raw materials can be obtained. This restriction is modified somewhat by the basing system employed by zinc producers and users.<sup>31</sup> The price of all zinc materials, i.e., ore, concentrates, products and scrap, is based on the f.o.b. East St. Louis price of prime western grade zinc slab plus or minus an established differential. The competitive position of the Sand Springs smelter is enhanced by its proximity to East St. Louis. Consequently, this plant is capable and does compete on both a national and world market.

---

<sup>30</sup>Ibid.

<sup>31</sup>Carl H. Cotterill, Industrial Plant Location, Its Application to Zinc Smelting (St. Louis, 1950), pp. 106-110.



## CHAPTER VI

### SUMMARY AND CONCLUSION

Zinc is one of the important metals forming the basis for modern industry. Although it ranks fourth in production and consumption in the United States, its usefulness and importance in our present economy is not fully appreciated by the average American. To understand the significance of an industry one must view it from its inception, study its progress and anticipate its future.

Metallic zinc, although used by man for at least 2000 years, was probably not known as a separate metal until the fifteenth or sixteenth century. Modern smelting began in Belgium in the early 1800's and by the late 1850's zinc smelting operations had begun in the United States.

Early smelters were located adjacent to raw materials, fuel and markets. As transportation facilities were extended into new areas, smelters were constructed along these routes at points where raw materials and fuel were available in large quantities at low cost. Prior to 1900 zinc smelting facilities were concentrated near the coal fields of Pennsylvania, Illinois and southern Kansas. Following the turn of the century, natural gas became available for smelter use in Kansas and later throughout the entire Gas Belt region. An accelerated smelter building program, based on natural gas fuel, followed; and by 1909 the United States had become the world's leading producer of zinc slab, a distinction it has continued to enjoy since that time.

Zinc slab production did not begin in Oklahoma until 1907 when two smelters were completed at Bartlesville. During the next ten years several more smelters were built in Oklahoma's Gas Belt and production of zinc slab increased until 1917 when a record high of 204,000 tons was produced. After 1917 production decreased rapidly and by 1921 production had dropped nearly 80 percent. The decline resulted in part from over-expansion during World War I, resulting in an oversupply of zinc on the world market after the war. Falling zinc prices forced many marginal producers to discontinue operations. Also, several plants were dismantled and moved to other areas because of an insufficient supply of natural gas for fuel. Between 1917 and 1929 ten of Oklahoma's fifteen smelters were either shut down and abandoned, or dismantled. At the present time Oklahoma's zinc smelting industry is composed of three primary smelters built between 1907 and 1916 and one secondary plant built in 1922.

Today the total domestic zinc smelting industry is composed of eighteen primary smelters or refineries and thirteen secondary plants located in fifteen states. Because of the interrelationship of numerous economic factors over 90 percent of the primary zinc slab capacity is concentrated in Pennsylvania, Montana, Oklahoma, Illinois and Texas. All primary smelters are located on good transportation routes, usually at a point near a source of cheap fuel and between the raw materials and market. Secondary plants are located in nine states adjacent to areas providing large markets, raw materials and cheap fuel, or a favorable combination of all three factors.

Four methods of primary zinc reduction are presently used by plants in the United States. Generally these reduction processes are associated

with specific geographic regions and are based on the availability of cheap natural gas, coal or electrical power. The older, less efficient horizontal retort plants are located in the Gas Belt of Oklahoma, Arkansas and northern Texas. Pennsylvania and West Virginia are characterized by vertical retort smelters which are either externally gas-fired or heated internally by an electrothermic carbon reduction process. Electrolytic plants in Idaho and Montana utilize inexpensive electrical power. The Illinois region has three smelters, one of each type. The fourth type of process, an electrothermic zinc slag furnace, is located at Herculaneum, Missouri. An electrolytic plant at Corpus Christi, Texas, uses electrical power produced by natural gas.

Zinc slab is classified into six commercial grades ranging from Prime Western, the least pure, to Special High Grade. Zinc prices are quoted in cents per pound for Prime Western grade, f.o.b., East St. Louis, Illinois. The other five grades receive a premium above the price of Prime Western.

During the past few years there has been an increasing demand for the two top grades, High Grade and Special High Grade, for use in the die cast industry, at the present time about 40 percent of the zinc slab produced is Prime Western.

The principal consumers of zinc slab are the galvanizing industry located adjacent to the steel industry, the die cast industry which is located near their customers, the automobile industry, and the brass mills which are located in the major industrial areas, particularly in Connecticut.

Since the beginning of World War II, zinc imports have become more and more important to our economy. Today about 50 percent of the ore

processed by domestic smelters is imported. The demand for imported slab also increased during this period. In 1957 zinc slab imports equalled about 20 percent of the domestic consumption.

Oklahoma's zinc smelting industry is composed of three primary smelters located at Blackwell, Bartlesville and Henryetta. One secondary plant is located at Sand Springs. Although production at the primary plants is based on the horizontal retort distillation process, each plant is unique in some respect.

In 1954 the roasting and sintering operations were discontinued at the Henryetta plant in favor of a centralized concentrate processing plant at Galena, Kansas. The by-products normally associated with these processes are no longer recovered at Henryetta. On the other hand, this plant operates the only Waelz kiln in Oklahoma. This furnace is used to concentrate low-grade ores imported from Mexico which otherwise could not be used. The Waelz kiln is also used to produce a germanium concentrate which is refined by Eagle-Picher at their rare metals plant at Miami, Oklahoma.

In 1951 the Blackwell plant installed a huge sintering machine capable of performing both the roasting and sintering operations simultaneously. This machine is the largest of its type in operation; however, another machine similar to it is being installed at another plant. Concentrates processed at Blackwell are extremely rich in cadmium. In 1957 new facilities were completed and recovery of cadmium began. Production reached one and one-half million pounds in 1958.

At the present time research is being conducted at Blackwell to improve a newly developed process of distillation refining which is capable of producing Special High Grade zinc and die cast metals.

Today, the Blackwell plant's production is based entirely on imported ores which are either mined or purchased by the parent company, American Metals Climax, Inc., for processing at Blackwell.

Production at the National Zinc Company's smelter at Bartlesville is also based to a great extent on imported ores; however, some domestic materials from Utah and Arizona are also used. In 1953 this plant replaced its old multiple hearth roasters with two Fluo Solids, fluid bed reactors which permitted greater recovery of by-product materials. The Bartlesville plant is the only primary smelter in Oklahoma producing by-product sulfuric acid, zinc dust and mercury.

Production at the American Smelting and Refining Company's secondary plant at Sand Springs is limited entirely to zinc dust at the present time; however, the plant is capable of producing secondary zinc slab.

From an economic point of view the zinc industry is extremely important to Oklahoma. At the present time these four plants employ about 2,000 men at a cost of nearly \$9,000,000 annually. Two of the three primary plants use natural gas produced in Oklahoma and most of the supplies used by these plants are purchased locally. Electrical power and water are also obtained from Oklahoma sources. In 1954 the value of products shipped was \$35,794,000 and the value added was \$13,847,000. Production of zinc slab in Oklahoma has averaged 153,700 tons during the past ten years. Generally speaking, for every dollar received for zinc produced in this state, about 25 cents remain in Oklahoma. This does not include an assumed profit of ten percent.

## Conclusion

There are many factors which should be taken into consideration in appraising the future of Oklahoma's zinc industry. In the first place, zinc products are faced with ever-increasing competition from aluminum, stainless steel and plastics. Although zinc is holding its own in most fields, its consumption is not increasing in proportion to either the increasing population or at the rate of competitive products. Another important factor is the continual shift in demand from Prime Western to High Grade and Special High Grade zinc. As a result, competition between horizontal retort plants for the decreasing Prime Western market will continue to increase until the less efficient plants are forced to modernize their processes, shut down, or move into areas where more favorable economic conditions exist.

The question as to how long Oklahoma's antiquated smelters will be able to compete against the more modern, more efficient plants, which produce high-quality products, can be answered only by analyzing the economic factors as they affect the operations at each specific smelter. Normally, if a plant was no longer capable of providing a fair return on the investor's money its operations would be discontinued. However, operations at some integrated plants will undoubtedly continue for a period after they are no longer economically justified simply because their facilities are available and their operation contributes toward the end product of the parent company.

In 1956, Fantus Area Research, Inc., of New York and Chicago completed an analysis of Oklahoma's Industrial Potentials. In their summary report to the Oklahoma Department of Commerce and Industry, this research organization recommended that the old horizontal retort plants

be replaced with modern vertical retort smelters. In this report Oklahoma was rated as an excellent area for the location of this industry. This report, however, did not rate or otherwise compare Oklahoma with other potential locations.<sup>1</sup> The feasibility of this recommendation is doubtful because other areas appear to be better situated with respect to locational factors. This opinion is substantiated by some officials at Oklahoma's plants who doubt that any large-scale facilities will be constructed in Oklahoma because of two important reasons: (1) due to the increasing dependence on imported ores the logical location of a smelter would be either abroad near the source of raw materials, or at or near the port of entry depending on the availability of fuel; and (2) fuel costs have continued to increase until "cheap" natural gas is no longer an incentive for location in Oklahoma.

The increasing significance of imported zinc materials must be carefully considered before any new domestic smelting facilities are constructed. In June, 1952, the President's Materials Policy Commission, under the direction of Chairman William S. Paley, made its report to the President. The Commission pointed out that by 1975 the United States would have to import an estimated 800,000 tons of zinc and produce another 800,000 tons from domestic sources to meet the projected demand of 1.6 million tons.<sup>2</sup> Total zinc consumption in 1957 had decreased to 1,231,593 tons from the all-time high of 1,469,080 tons reached in 1955.

---

<sup>1</sup>Summary of Oklahoma's Industrial Potentials, Report to the Oklahoma Department of Commerce and Industry by Fantus Area Research, Inc. (New York, 1956), pp. 3, 16-17.

<sup>2</sup>Resources for Freedom, President's Materials Policy Commission, Vol. II, "The Outlook for Key Commodities" (Washington, 1952), pp. 45-47.

Although the total demand has fluctuated widely during the past few years, imports have continued to increase as predicted by the Commission. In fact, imports of ore and slab reached 794,764 tons in 1957 and will undoubtedly far exceed the predicted 800,000 tons by 1975.

The problems of the zinc industry can be solved only through continued research. If zinc is to maintain its relative position in regard to production and consumption, it must be produced at a competitive price. Improved techniques are needed in mining, milling, smelting and marketing. The American Zinc Institute is dedicated to this end. According to its constitution, "the purpose of the Institute is to promote the welfare of the zinc industry by affording a means of communication between members upon matters bearing upon their business interests."



## SELECTED BIBLIOGRAPHY

### Government Documents

- Eisenhower, Dwight D. "Modification of Trade Agreement Concessions and Imposition of Quotas on Unmanufactured Lead and Zinc," Presidential Proclamation (September 22, 1958).
- President's Materials Policy Commission, Resources for Freedom, Vol. I "Foundations for Growth and Security," Washington: Government Printing Office, 1952.
- President's Materials Policy Commission, Resources for Freedom, Vol. II "The Outlook for Key Commodities," Washington: Government Printing Office, 1952.
- U. S. Bureau of Census. Census of Manufacturers 1954, Vol. II, "Industry" Part 2. Washington: Government Printing Office, 1957.
- U. S. Bureau of Census. Census of Manufacturers, 1954, Vol. III, "Area Statistics." Washington: Government Printing Office, 1957.
- U. S. Bureau of Mines. Materials Survey; Zinc. Washington: Government Printing Office, 1951.
- U. S. Bureau of Mines. Mineral Facts and Problems, Bulletin 556. Washington: Government Printing Office, 1956.
- U. S. Bureau of Mines. Minerals Yearbook, Part I. Washington: Government Printing Office, 1932-1957.
- U. S. Geological Survey. Mineral Resources of the United States, Part I. Washington: Government Printing Office, 1901-1931.
- U. S. Tariff Commission. Lead and Zinc Industries, Report No. 192. Washington: Government Printing Office, 1954.
- U. S. Tariff Commission. Lead and Zinc, Report to the President on Escape-Clause Investigation, No. 27. Washington: Government Printing Office, 1954.
- U. S. Tariff Commission. Lead and Zinc, Report to the President on Escape-Clause Investigation, No. 65. Washington: Government Printing Office, 1958.

## Annual Reports

American Metals Climax, Inc., Annual Report, 1958 (New York, 1959).

American Smelting and Refining Company 60th Annual Report 1958 (New York, 1959).

Eagle-Picher Company Annual Report for 1958 (Cincinnati, 1959).

## Personal Interviews

Clancy, Bill. Engineering Department, Blackwell Zinc Company, Blackwell, Oklahoma (June 3, 1959).

Fraiser, James F. Office Manager, Blackwell Zinc Company, Blackwell, Oklahoma (June 3, 1959).

Hughen, Marvin L. Plant Manager, Blackwell Zinc Company, Blackwell, Oklahoma (June 3, 1959).

Lakios, S. J. Plant Superintendent, American Smelting and Refining Company, Federated Metals Division, Sand Springs, Oklahoma (May 5, and June 5, 1959).

McCall, Dale. Safety Director, Eagle-Picher Company, Henryetta, Oklahoma (June 5, 1959).

Redfield, Leonard. Office Manager, Eagle-Picher Company, Henryetta Oklahoma (June 5, 1959).

Van Aken, J. S. Smelter Superintendent, National Zinc Company, Bartlesville, Oklahoma (June 9, 1959).

## Periodicals

Brown, John S. "A Graphic Statistical History of the Joplin or Tri-State Lead-Zinc District," Mining Engineering, Vol. 3 (September 1, 1951).

Ince, Charles R. "Zinc," Engineering and Mining Journal, Vol. 159 (February, 1958).

Leslie, E. H. "Collinsville Smelter of the Bartlesville Company," Mining and Scientific Press, Vol. 109 (August 8, 1914).

Renner, George T. "Geography of Industrial Localization," Economic Geography, Vol. 23 (1947).

Shelton, S. M. and W. E. Duncan. "Zinc Metallurgy Far From Static," Engineering and Mining Journal, Vol. 140 (February, 1939).

## Books

- Alderfer, B. E. and H. E. Michl. Economics of American Industry. 3d ed. New York: McGraw-Hill Book Company, Inc., 1957.
- Bateman, Alan M. Economic Mineral Deposits. New York: J. Wiley and Sons, Inc., 1942.
- Bidwell, P. W. Raw Materials: A Study of American Policy. New York: Harper, 1958.
- Brady, George S. Materials Handbook. 8th ed. New York: McGraw-Hill Book Company, Inc., 1956.
- Cotterill, Carl H. Industrial Plant Location, Its Application to Zinc Smelting. St. Louis: American Zinc, Lead and Smelting Company, 1950.
- Davies, Oliver. Roman Mines in Europe. Oxford: Clarendon Press, 1935.
- Forbes, R. J. Metallurgy in Antiquity. Leiden: E. J. Brill, 1950.
- Friedrich, C. J. Alfred Weber's Theory on Location of Industries. Chicago: University of Chicago Press, 1929.
- Holmes, W. Gerald. Plant Location. New York: McGraw-Hill Book Company, Inc., 1930.
- Hoover, T. J. The Economics of Mining. 3d ed. Stanford: Stanford University Press, 1948.
- Ingalls, W. R. Lead and Zinc in the United States. New York: McGraw-Hill Book Company, Inc., 1908.
- \_\_\_\_\_. World Survey of the Zinc Industry. New York: Mining and Metallurgical Society of America, 1931.
- Kitson, H. W. "The Mining Districts of Joplin and Southeast Missouri," Mining Practices. New York: McGraw-Hill Book Company, Inc., 1919.
- May, Elizabeth S. et al. International Control of Non-Ferrous Metals. New York: The Macmillan Company, 1937.
- Mouzon, Olin T. International Resources and National Policy. New York: Harper, 1959.
- Skelton, Alex et al. International Control of Non-Ferrous Metals. New York: The Macmillan Company, 1937.
- Smith, Ernest A. The Zinc Industry. London: Longmans, Green and Company, 1918.

Snyder, Edward H. and Ernest V. Gent. "The Zinc Industry," The Development of American Industries. Eds. Glover, John G. and William B. Cornell. 3d ed. New York: Prentice Hall, 1951.

Voskuil, H. W. Minerals in World Industry. New York: McGraw-Hill Book Company, Inc., 1955.

Yearbook of the American Bureau of Metal Statistics for 1957. York, Pa.: The Maple Press Company, 1958.

#### Pamphlets

Fantus Area Research, Inc. Summary of Oklahoma's Industrial Potential, Report to the Oklahoma Department of Commerce and Industry (New York, October 8, 1956).

"The Story of the Tri-State Zinc and Lead Mining District," Souvenir Booklet. Joplin: Joplin Printing Company, 1931.

#### Newspapers

Feen, John. "Salute to Eagle-Picher Company," Miami Daily News-Record, Miami (August 19, 1956).

Grant, Margaret. "National Zinc Company to Observe Golden Anniversary," The Bartlesville (Okla.) Examiner-Enterprise, Bartlesville (October 10, 1957).

"Henryetta Recalls Day He Came Here to Give Life to Eagle-Picher Zinc Smelter," Henryetta Daily Free-Lance, Henryetta (April 25, 1951).

"National Zinc Company is Pioneer Industry of Bartlesville," The Bartlesville (Okla.) Examiner-Enterprise, Bartlesville (October 10, 1957).

## VITA

Roland Deloy Mower  
candidate for the degree of  
Master of Science

Thesis: THE ZINC SMELTING INDUSTRY IN OKLAHOMA

Major: Geography

### Biographical:

Personal Data: Born December 25, 1928 at Mt. Pleasant, Utah.

Education: Attended grade and Junior High School at Fairview, Utah; graduated from North Sampete High School, Mt. Pleasant, Utah in 1949; received the Bachelor of Science degree from the University of Utah, with a major in Geography in June, 1955; completed requirements for the Master of Science degree in August, 1959.

Professional experience: Served in the United States Navy from 1945 to 1948. Entered the United States Air Force in 1955. Present status, First Lieutenant, Vance Air Force Base, Oklahoma.