

ARCH.
LIBRARY
Thesis
1985R
H249m
v.1



A MULTI - USE SPORTS FACILITY FOR OKLAHOMA CITY, VOL. 1

VOLUME ONE

SITE ANALYSIS, RESEARCH

A MULTI-USE SPORTS FACILITY
FOR OKLAHOMA CITY

VOLUME ONE

SITE ANALYSIS, RESEARCH

This Volume is part of a two volume series and contains the Site Analysis and Research for the Oklahoma City Multi-Use Sports Facility. Volume Two is bound under a separate cover and contains the Area Requirements.

JOHN J. HANSEN

MULTI-USE SPORTS FACILITY, OKLAHOMA CITY

Special thanks to the following people who were vital to the development of this program and will be instrumental to the completion of this design problem in the Spring of 1985.

Client Mr. Edward Cook
 President of the Chamber of Commerce
 Chamber of Commerce Building
 Oklahoma City

Technical:Mr. Walt Joyce
Advisor RGDC Engineering Company
 10101 S. Penn Avenue
 Oklahoma City

Program :Professor Alan Brunken
Consultant 101 Architecture Building
 Oklahoma State University
 Stillwater, Oklahoma

Advisor: Professor George Baumiller
 101 Architecture Building
 Oklahoma State University
 Stillwater, Oklahoma

Structure:Professor Louis Bass
Advisor 101 Architecture Building
 Oklahoma State University
 Stillwater, Oklahoma

Acknowledgements

This Program is dedicated to my mother and father,
C.J. and Wanda Hansen for their never-ending love
and support, my wife Cammie for always standing
by my side, and my daughter Kelci for whom this
is for.

Dedication

MULTI-USE SPORTS FACILITY, OKLAHOMA CITY

TABLE OF CONTENTS

--

--

MULTI-USE SPORTS FACILITY, OKLAHOMA CITY

Table of Contents

	<u>Page No.</u>
User Types	1
Type of Events	3
Summary of Project	4
Statement of the Problem	5
Function	6
Form	6
Economy	7
Time	7
Goals and Concepts	8
Function	9
Form	13
Economy	14
Time	16
Site Analysis	17
Temperature	18
Precipitation	19
Winds	20
Sun Angles	21
Location of Site, general	22
Location of Site, city	23
Priority Street Maintenance	24
Transit Improvement Priorities	25
Major Highway Projects	26
Vehicular Circulation	27
Site Boundaries	28
Contours	29
Site Entrances	30
Existing Parking	31
Photographic Survey	32
Vegetation	37
Views from Site	38
Views to Site	39

Table of Contents (cont.)

	<u>Page No.</u>
Codes and Zoning	40
1981 BOCA Codes	41
Zoning Ordinances	45
Design Data	48
Seating Area	49
Seating Capacity	56
Circulation in Seating Area	53
Locker Room Facilities	61
Training Room Facilities	65
Playing Field Layouts	67
Relationships	70
Spectator	72
Administration	73
Media	75
Franchise Office, Basketball	76
Franchise Office, Football	80
Service	84
State of the Art	86
Montreal Olympic Center	87
Sports Arena, Iowa City, Iowa	91
Kemper Arena, Kansas City	95
New Orleans Superdome, Louisiana	98
General Stadium Sections	101

USER TYPE AND RELATIONS

User type can be broken down into five basic user groups which include Spectators, Administration, Media, Franchise Offices, and Service to the facilities.

The Spectator role is the attendance of the event for entertainment. The Spectator can be from the State Fairgrounds or the Spectator can be an individual that has come to see a particular event such as a concert or a Rodeo. The Spectator mood should be set before the event so the entrance process becomes very important and should reflect the atmosphere of the event for the Spectator. The Spectator is the one that the event is put on for and it should reflect this in the design and layout of the complex.

Administration role is for the upkeep and running of the complex itself and is in charge of all management decisions. The administration works in the complex year round so the facilities should be pleasant and reflect the atmosphere of the stadium. The administration is responsible for all activities and events.

The Media role is to cover and record events as they happen. The media use of the stadium is only during a particular event or activity and the media is responsible for the coverage of all events.

Franchise Office role is to promote the athletic club for which they own. They are also responsible to promote the athletic event for the spectator and have offices for the organization in the stadium complex.

Spectator
Administration
Media
Franchise Offices
Service

The Service Role is the physical upkeep and maintenance of the facility complex. This includes the setting up before events and clean-up after events. Also included is general maintenance for maintaining the facility in a good working condition.

User relations vary from facility to facility. The needs for the relations in a particular sports facility are determined by the activities that are going to be held in the particular complex.

Administration Relations should be indirectly related with every aspect of the stadium complex but mostly direct relations should be with the media organization, franchise organization, and indirectly with the service facilities.

Media relations vary but should be indirectly related to the administrative offices. There should be a strong relation and link though with the Franchise Organization clubs and dressing areas for interviews after events and club announcements.

Franchise Offices relations are mostly with the Administrative Offices. Relations are also minimally with the Spectator. Franchise Offices also need a minimal relation with the media for the announcement of events, trades, and club activities.

Service should be related with the Administrative Offices and have access to all areas of the Sports Complex

Type Of Events

The facility arena area shall be as flexible as possible so that any major event may take place. Moveable seating on the lower level is necessary for the flexibility to happen. The events could be almost anything but a listing of fixed events is available.

The Client needs for the complex is to be as flexible as possible so that almost any event that comes along will be able to be accomodated by the complex.

List of Events.

National Finals Rodeo
Professional Football
Professional Basketball
Conventions
Concerts
High School Sports
Entertainment Events
Exhibition Conferences

The Multi-Use Sports Facility will be a major sports and entertainment complex for Oklahoma City and will be the first complex of this size in Oklahoma. The facility is located adjacent to the existing Oklahoma State Fairgrounds on a relatively flat site next to two major interstate highways and include the following:

Parking for 30,000 automobiles and buses

Seating facility for approximately 55,000-70-000 persons.

A complete administrative and training facility for professional football organization to be open year-round.

A complete administrative and training facility for a professional basketball organization to be open year-round.

Administrative offices and support facilities for the complex to function that will be open year-round.

An arena layout to provide flexibility so that the complex can be host to a multitude of various events.

Summary of Project

STATEMENT OF THE PROBLEM

[Empty rectangular box for the statement of the problem]

[Empty rectangular box for the statement of the problem]

Function:

Since the sports complex is to function for a wide variety of athletic, community, and administrative activities, conflicts in circulation and functional relationships should be minimized while promoting a positive interaction between spectators, athletes, and administrative personell.

Since one of the primary functions of the complex is the viewing of events, the various seating areas should provide comfort while allowing for the best views and should be easily accessible and exitable by the spectators.

Due to the large number of spectators viewing the events, the circulation halls and exit/entry areas should be large and easy to move through and be able to handle large crowd surges for intermissions and end of events.

Since the administrative departments personell are just as important as the spectators, the physical layout should provide for the ease of movement, centralization of activities, and a good mix of public/private interaction for the various administrative areas.

Form:

Since the sports complex accomodates several thousand spectators, many that are visitors, the overall design must allow the individual to easily identify the entry, maintain a strong sense of orientation and understand how the building is organized for ease of movement.

Since the site is located next to a major intersection of Interstate highways with high visibility and the Oklahoma State Fairgrounds with a strong sense of identity, the design should act as a jewel for the community and the region while promoting the atmosphere and identity of the State Fair.

Economy:

Since the sports complex will be used throughout the year, the complex must employ lower operating cost and maintenance cost by considering the use of energy efficient methods, materials and systems.

Time:

Since the nature of the project does not allow phasing and the project budget is limited, the entire complex should be built as a single complex considering materials, finishes, and construction methods for effects on quality, time, and cost.

GOALS AND CONCEPTS

A large, empty rectangular box with a black border, occupying the upper half of the page. It is intended for the user to write goals and concepts.A large, empty rectangular box with a black border, occupying the lower half of the page. It is intended for the user to write additional goals and concepts.

Goal: To provide a facility that will accomodate several types of activities from large spectator events to open floor exhibits.

Concept: The use of moveable seating arrangements in the arena area to provide the flexibility needed to accomocate the different events.

Concept: The use of a changeable flooring system to allow a conversion in function and space needed for the various events.

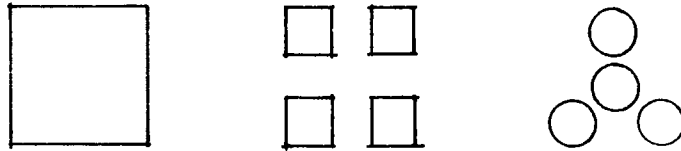

Goal: To give special consideration to the spectator to insure comfort and enjoyment of activities and events.

Concept: The spectators are the largest and most important support group of the sports facility, and good good seating, adequate refreshment areas and toilet spaces should be provided and easily accessible from any seating area.

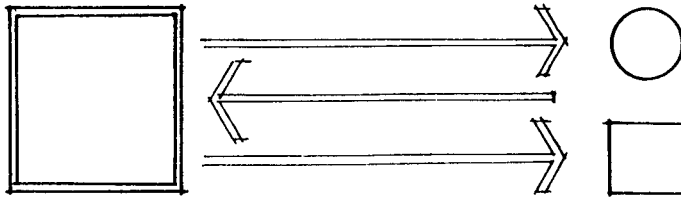

FUNCTION:

Goal: To provide easy and direct access to the sports facility for pedestrian and vehicular traffic.

Concept: Pedestrian and vehicular traffic should be separated and clearly marked with control of visual and physical access to the various entries.

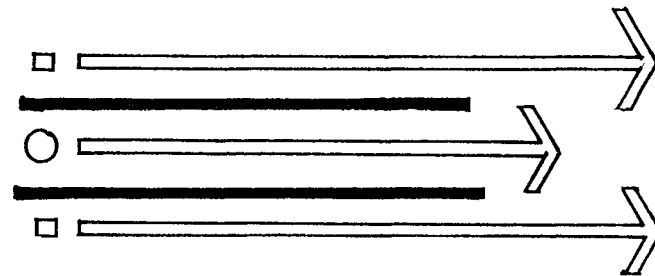

Goal: To provide efficient and organized circulation within the facilities for the spectator athletes, media, and administrative people.

Concept: Since the arena area is the focal point of the sports complex, all support areas and circulation should have direct access to and from this area.

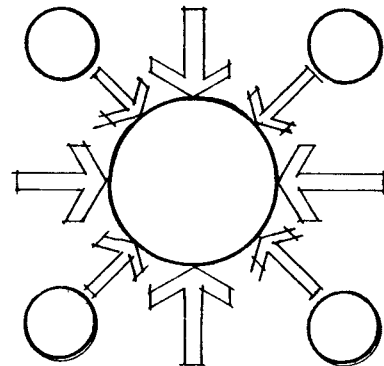

FUNCTION

Goal: Provide an atmosphere that is clearly defined and unconfused to participants, spectators, media, and other related persons.

Concept: Provide awareness of orientation at all times for the spectators, athletes, and media.

Concept: Provide a circulation system that is clearly definable and easily understood.

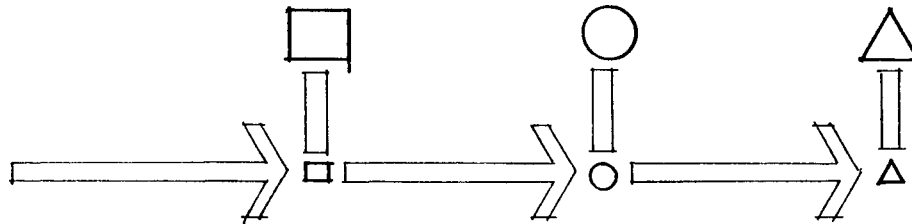

Goal: Provide for the safety and health of the building users and occupants.

Concept: Comply with all code requirements, including egress, fire protection, occupancy loads, etc.

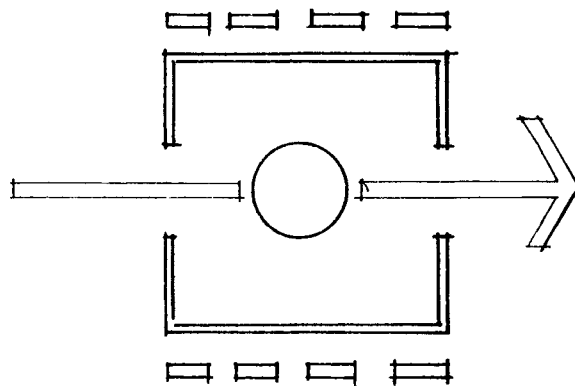

FUNCTION

Goal: The grouping of services and activities must be well defined and provide the consideration for functional efficiency and privacy to minimize public/service conflicts and maintain security.

Concept: Group activities to provide maximum interaction and efficiency between users and spaces.

Concept: Group service activities such as concessions, restrooms, and building services with links to other areas.



Goal: To improve and reorganize the existing parking sub-structure to provide a more efficient and comprehensible parking system.

Concept: To organize the parking areas into a single parking system of areas with a main circulating road for movement from one area to another.

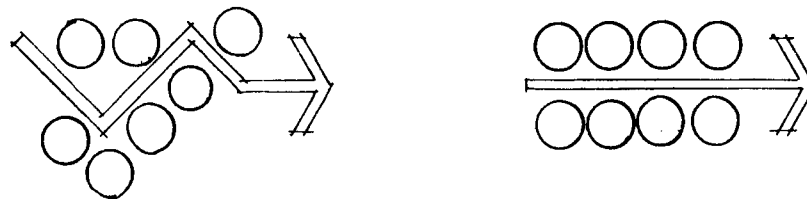

FUNCTION

Goal: To provide a sense of entry and an entry sequence into the complex for the spectator as well as administration and athletes from Interstate to the seats.

Concept: To provide an entry sequence of spaces to the complex to set the mood for the upcoming events.

Concept: Provide a well defined and highly visible entrance to the complex for a strong sense of entry and identity for the individual.

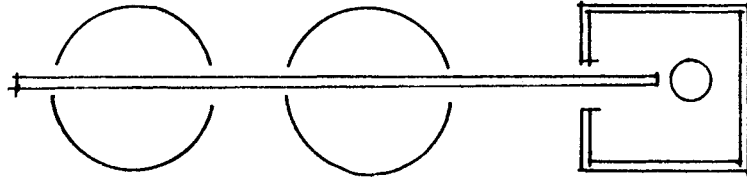

Goal: To project an image that implies the function of the complex and the direction of growth in the future for the city.

Concept: The project should be of a grand scale on the exterior appearance and in the main public areas.

Concept: The use of bright and colorful materials to provide a highly visual image.

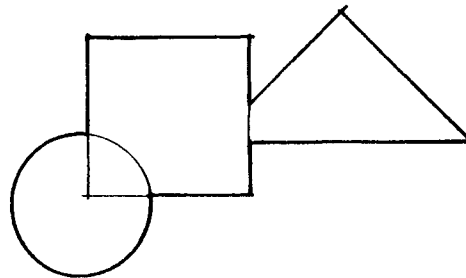

FORM

Goal: The facility should be designed with the awareness of energy conservation.

Concept: To control and utilize the sun and wind for maximum efficiency of climate control.

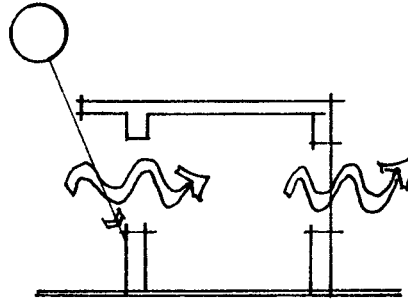

Goal: The facility should be designed to minimize operation costs.

Concept: The use of energy efficient methods, materials, and systems should be implemented to help control operation costs and make use of passive and active solar systems.

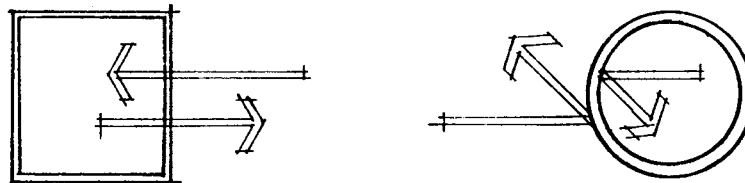

FORM

ECONOMY

Goal: The facility should be designed to minimize maintenance and repair costs

Concept: The use of low maintenance, highly durable materials, systems, and equipment to save in maintenance and upkeep costs over time.

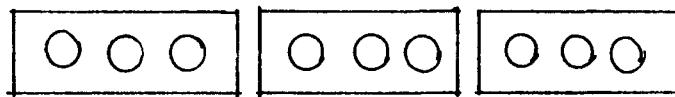

Goal: Through the use of design to control and minimize initial building costs.

Concept: Since the project is only a single phase project and the budget is limited, initial costs should be kept to a minimum while materials and systems should be selected to be durable and withstand time to minimize life-cycle costs.

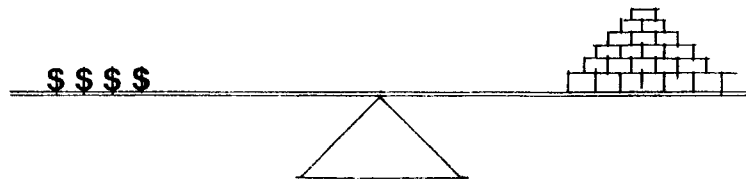

ECONOMY

Goal: The facility should be designed to be used throughout the year and at any time of the day for the various users.

Concept: Spaces should be accessible through the use of zoning for both people and environmental control systems.

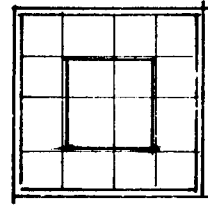
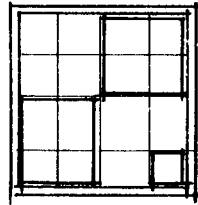

Goal: The facility should be developed to anticipate program changes in both the near and distant future.

Concept: The areas and spaces should be adaptable and convertible with room for growth and changes in programming.

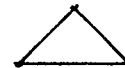
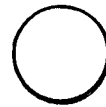
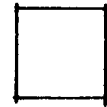
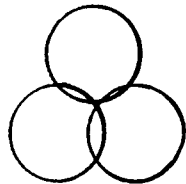

TIME

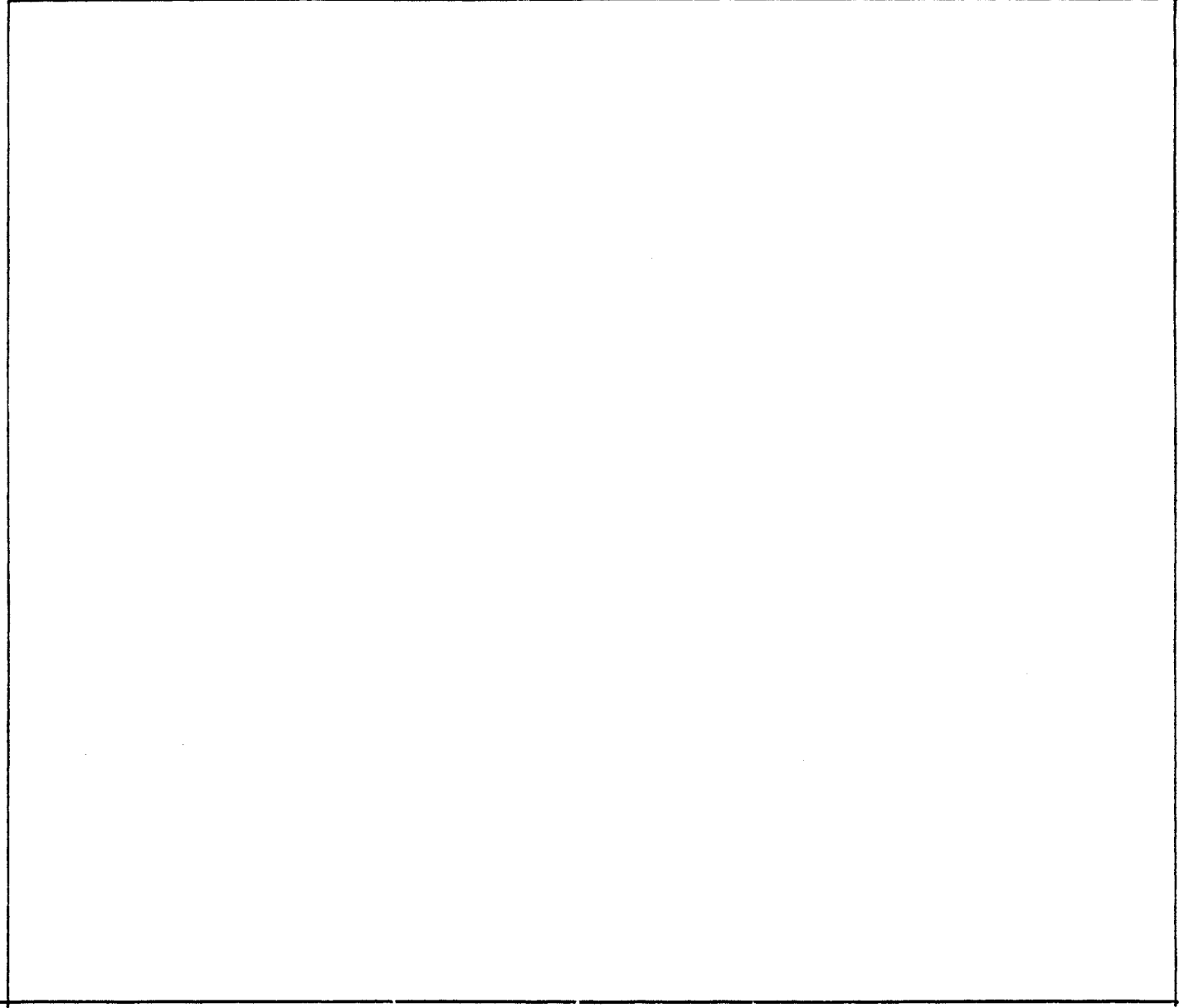
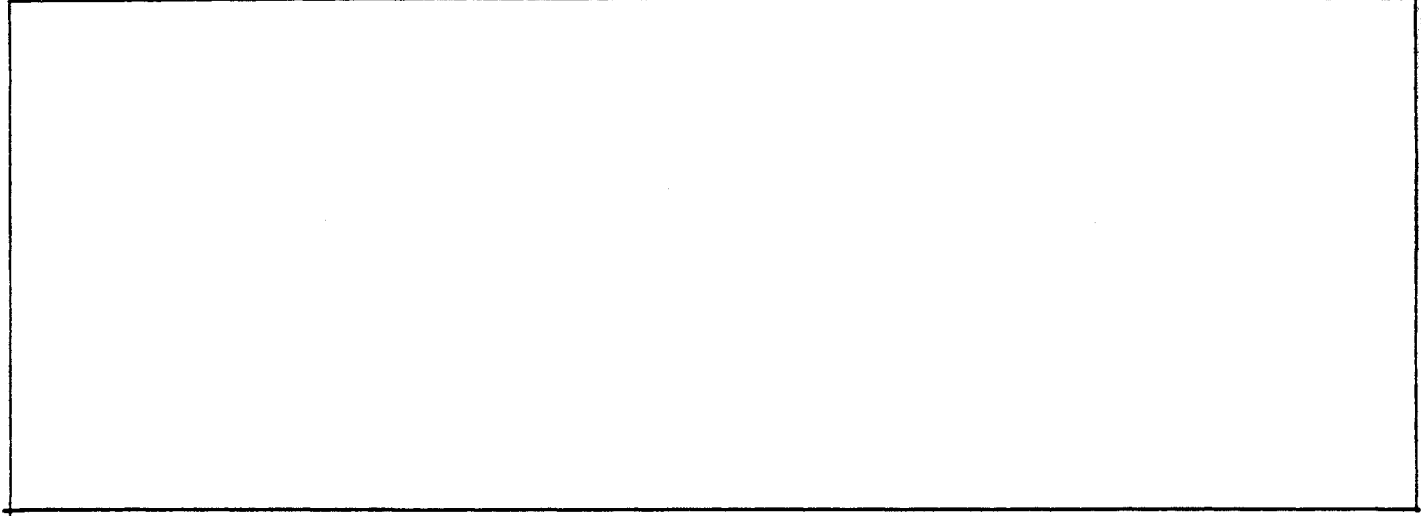

Mean # days 90° & above	0	0	0	0	2	11	20	20	10	1	0	0
Mean # days 32° & below	20	16	8	1	0	0	0	0	0	1	7	17
Heating Degree Days	868	664	527	189	34	0	0	0	15	164	498	766

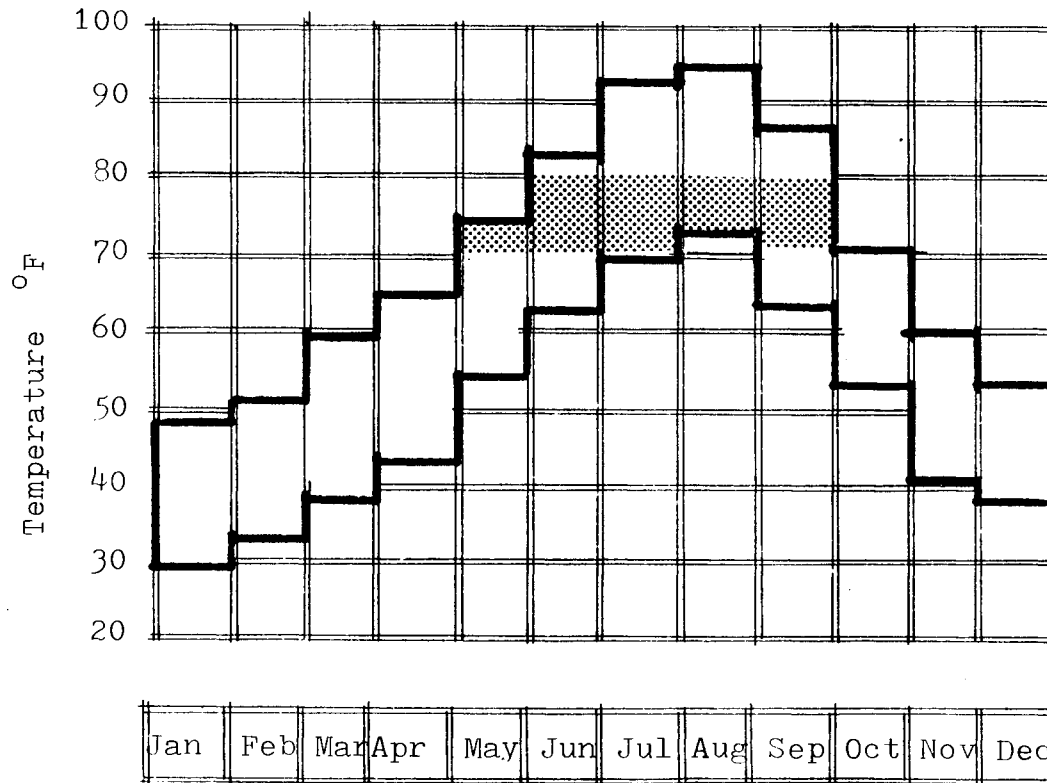

Temperature

	Avg. Min.	Avg. Max.	Avg. Max.
Jan	29.2	38.6	47.9
Feb	33.6	42.6	51.5
Mar	38.5	48.8	59.1
Apr	42.8	54.0	65.1
May	53.9	64.6	75.3
Jun	63.3	73.4	83.4
Jul	70.4	81.6	92.7
Aug	73.1	84.0	94.9
Sep	63.0	74.9	86.8
Oct	53.6	60.7	71.8
Nov	40.7	50.4	60.1
Dec	37.8	43.2	53.5

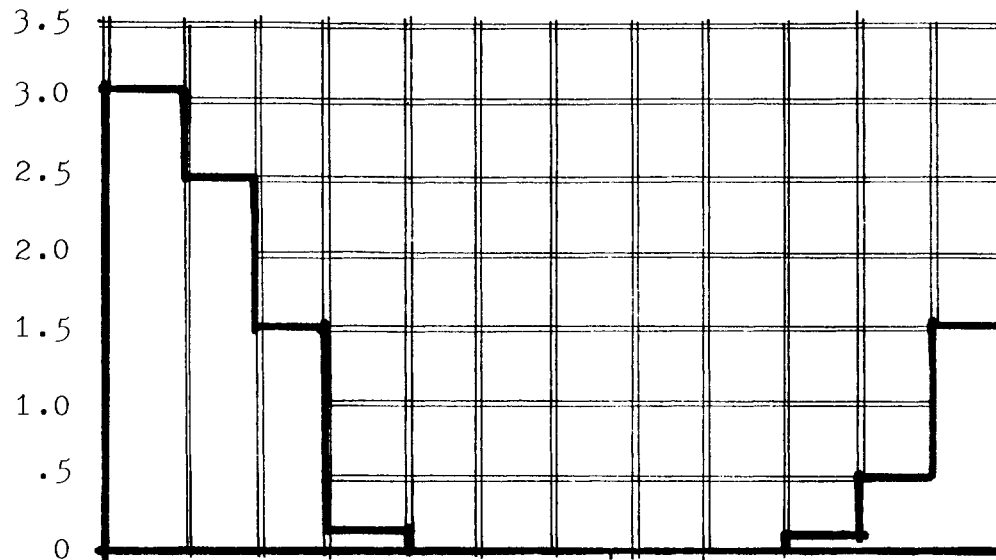

Snowfall (inches)

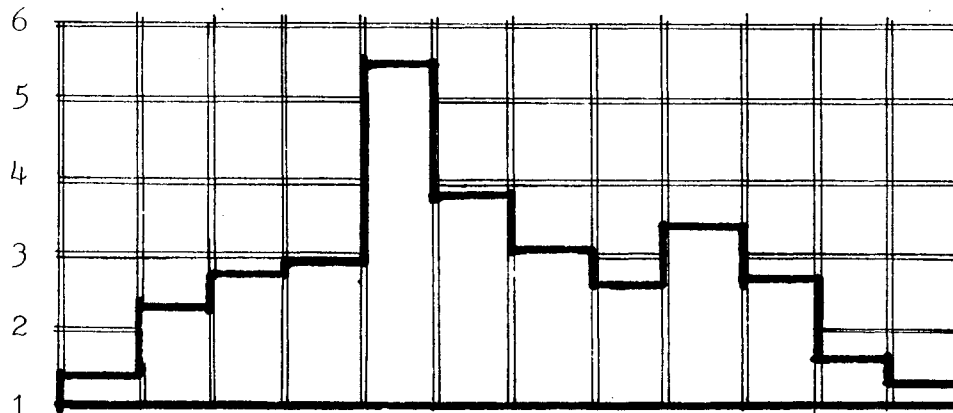

Rainfall (inches)

Jan	Feb	Mar	Apr	May	Jun	Jul	Aug	Sep	Oct	Nov	Dec
-----	-----	-----	-----	-----	-----	-----	-----	-----	-----	-----	-----

Precipitation

	Rain	Snow
Jan	1.38	3.1
Feb	2.30	2.5
Mar	2.70	1.5
Apr	2.91	trace
May	5.50	-
Jun	3.87	-
Jul	3.04	-
Aug	2.60	-
Sep	3.45	-
Oct	2.71	trace
Nov	1.53	.5
Dec	1.26	1.5
Ann.	33.25	9.6

Record Winds

63	61	61	75	72	87	73	56	54	65	66	56
W	W	S	NW	SE	NNW	NW	S	NW	S	S	NW

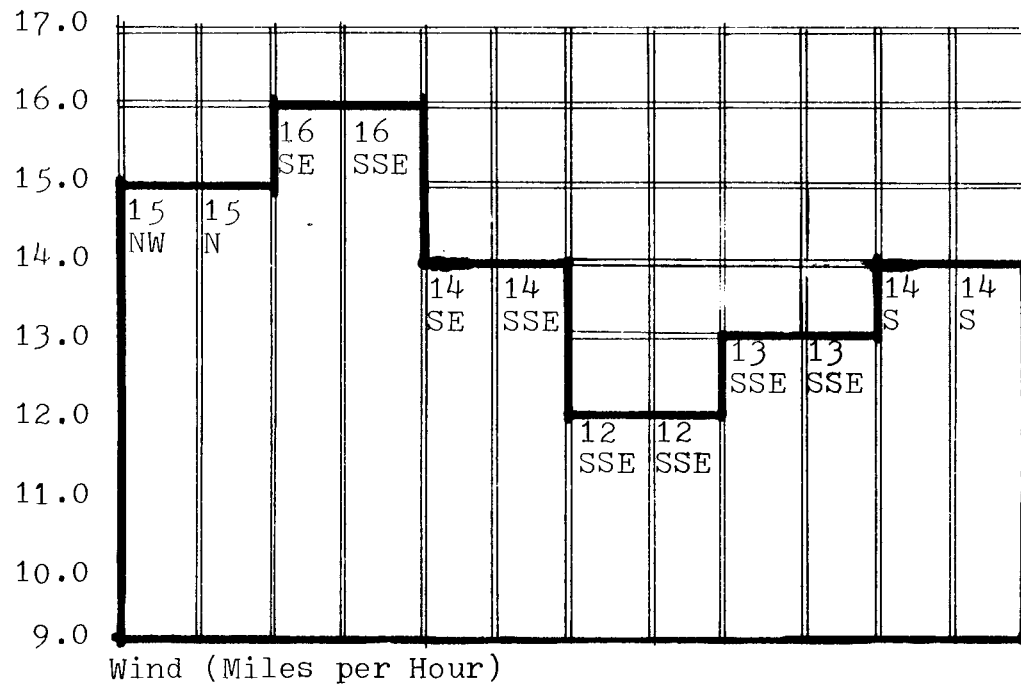

Jan	Feb	Mar	Apr	May	Jun	Jul	Aug	Sep	Oct	Nov	Dec
-----	-----	-----	-----	-----	-----	-----	-----	-----	-----	-----	-----

*indicates direction from which wind was blowing

Winds

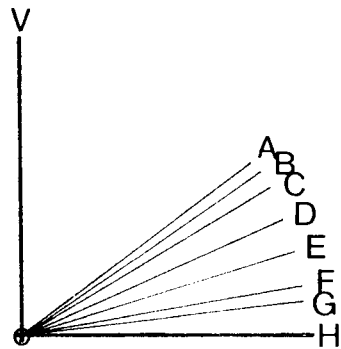

4:00 p.m.

Solar Altitude

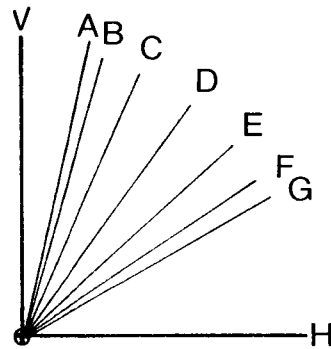

12:00 noon

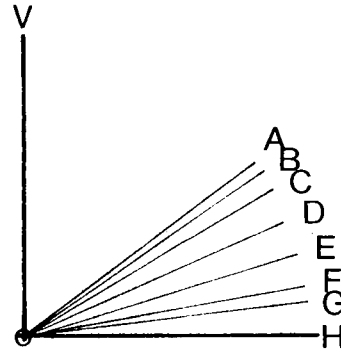

8:00 a.m.

Solar Azimuth

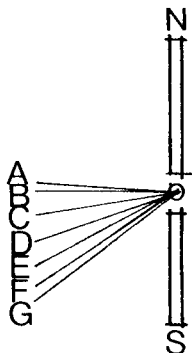

4:00 p.m.

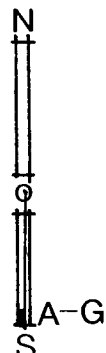

12:00 noon

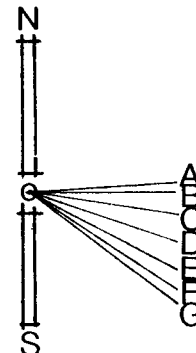

8:00 a.m.

Sun Angles

Solar Altitude

37	77	37
36	74	35
30	66	31
24	54	24
17	43	17
10	34	10
8	30	7

Solar Azimuth

94	0	94
90	0	90
81	0	82
71	0	72
62	0	63
55	0	56
53	0	53

A	June 21
B	May, July 21
C	April, August 21
D	March, September 21
E	Feb, October 21
F	January, November 21
G	December 21

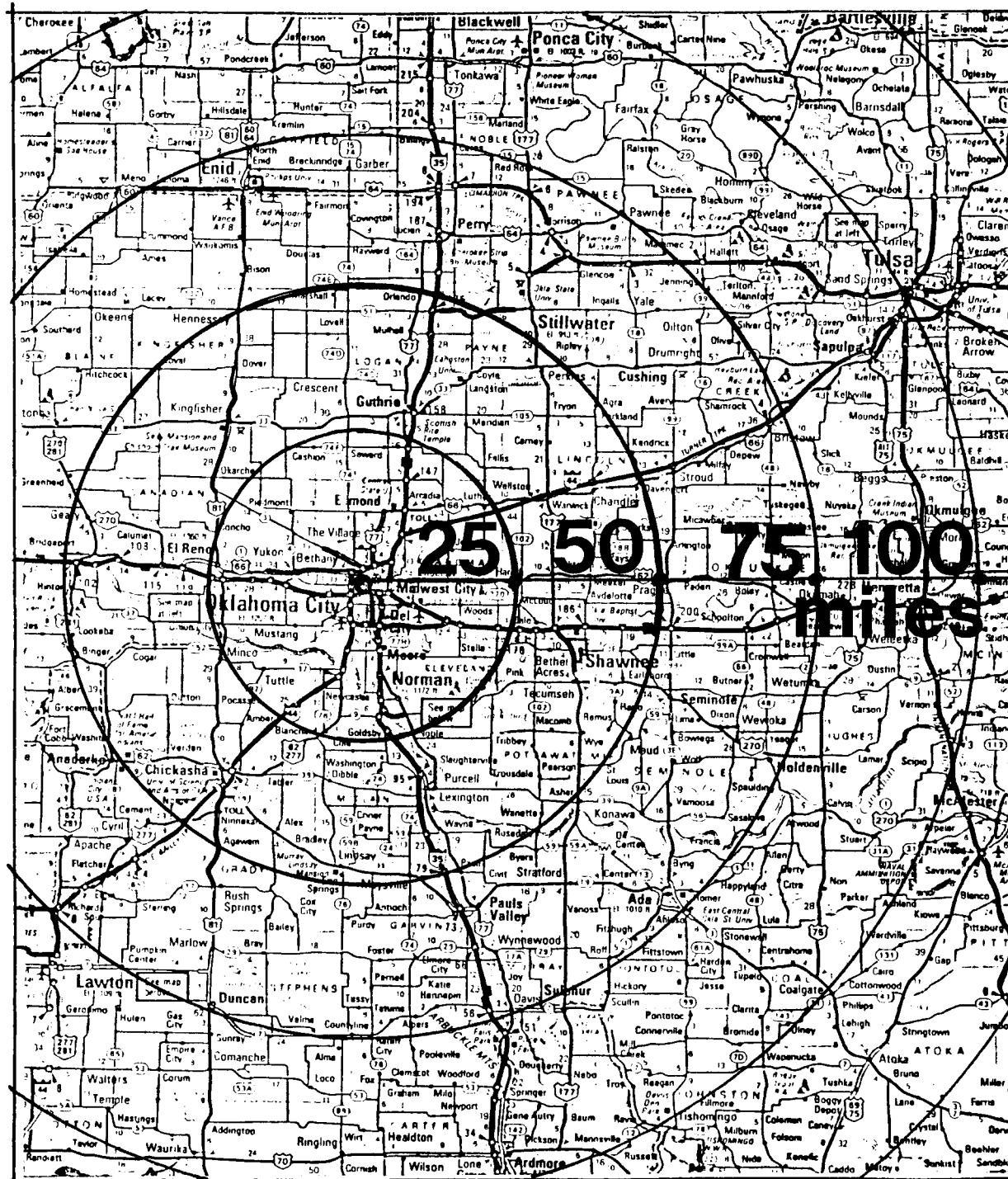

Location of Site
General

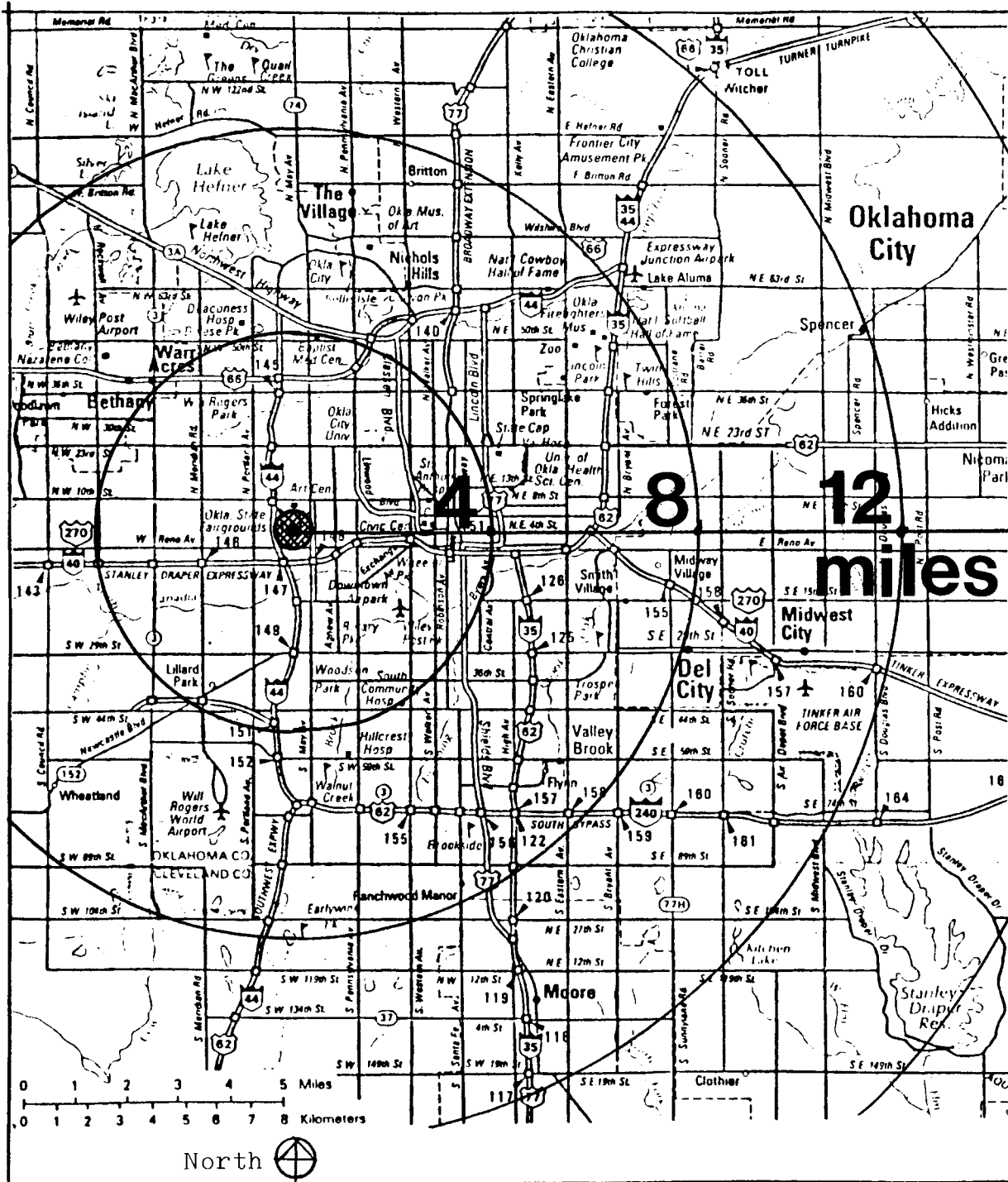



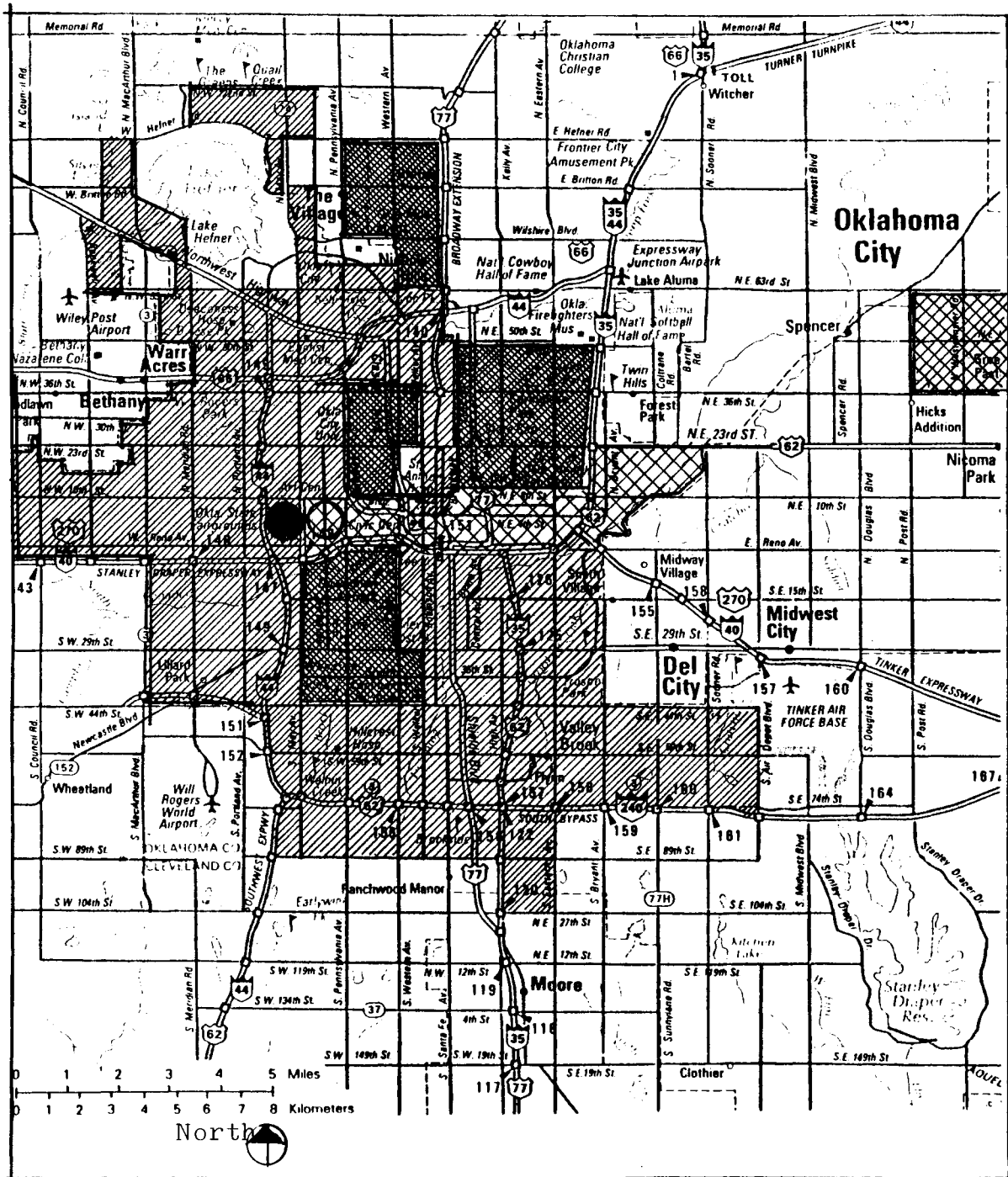

Location of Site
City

 Site

MULTI-USE SPORTS FACILITY, OKLAHOMA CITY





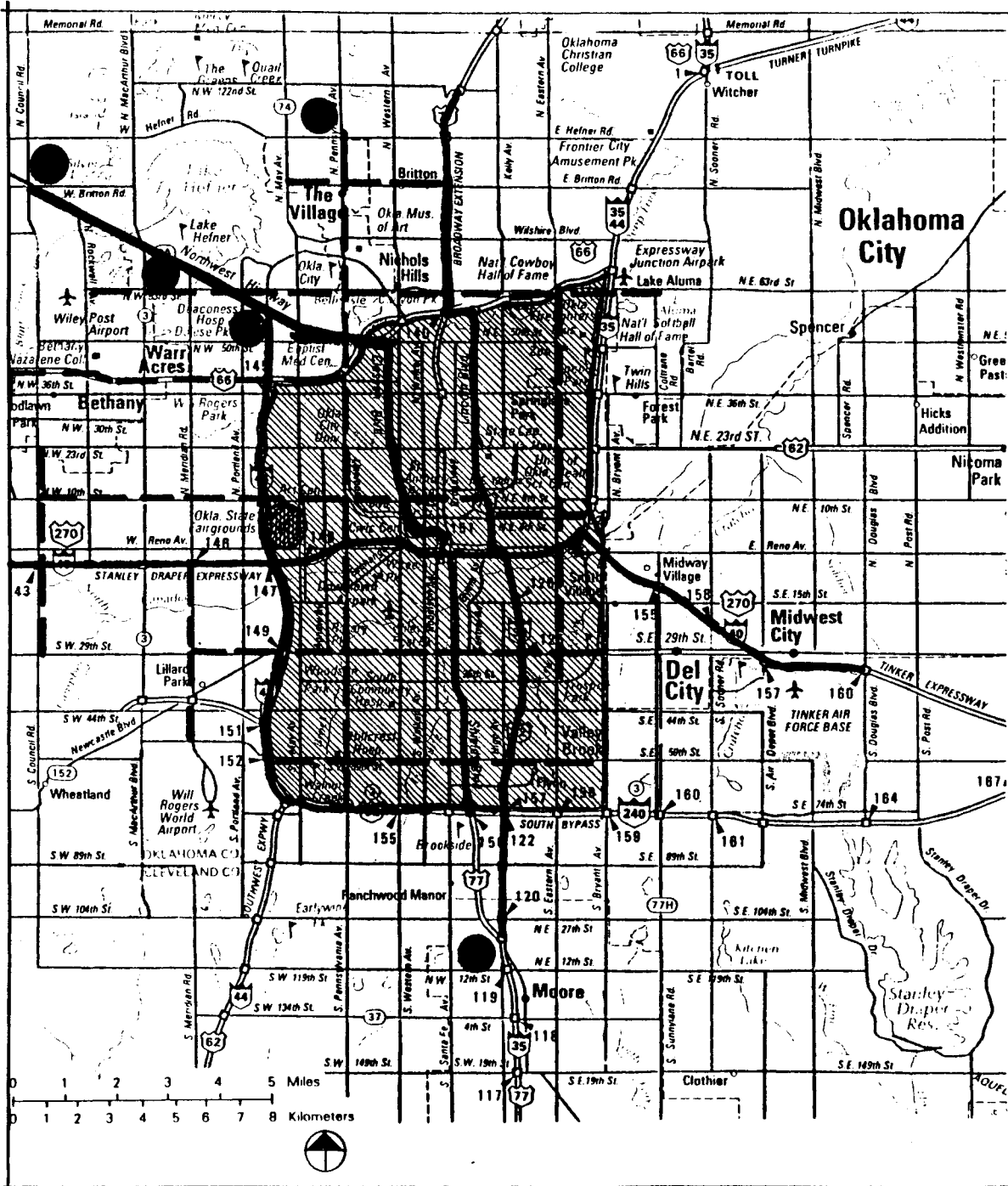

Priority Areas for Street Maintenance

-  Concentrated Maintenance and Upgrading
-  Routine Maintenance and Correction of Problems
-  Special Maintenance For Severe Problems Only
-  Site

MULTI USE SPORTS FACILITY, OKLAHOMA CITY

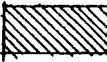



Transit Improvement Priorities

-  Market Oriented Bus Service Areas
-  Activity Routes
-  Express Bus Routes
-  Park and Ride Facilities
-  Site

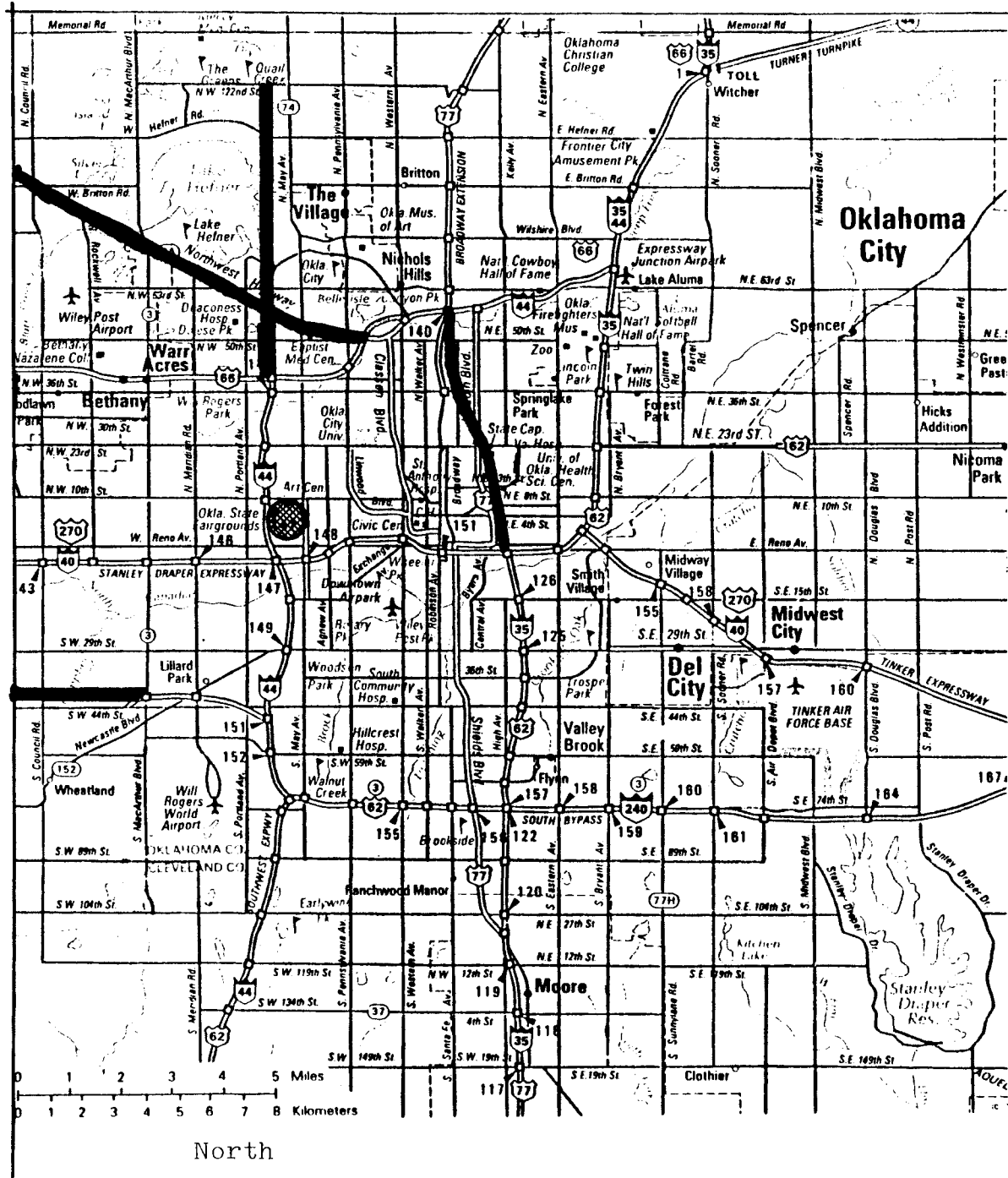
MULTI-USE SPORTS FACILITY, OKLAHOMA CITY



Major Highway Projects
1977-1987

-  Extension of Major Highways
-  Site

0 1 2 3 4 5 Miles
0 1 2 3 4 5 6 7 8 Kilometers

North

MULTI USE SPORTS FACILITY, OKLAHOMA CITY

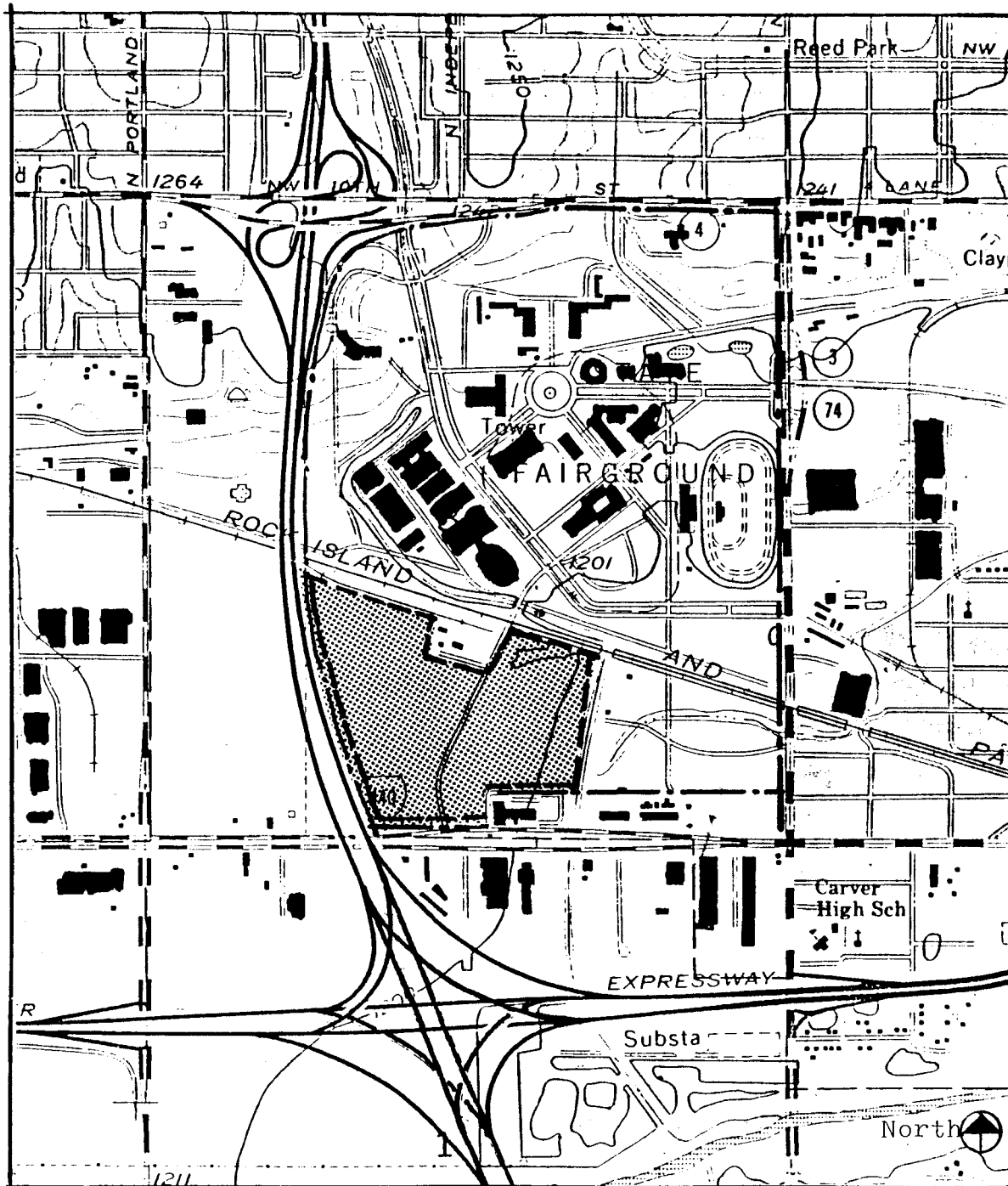

Site Boundaries

- State Fairgrounds
- Site Boundary
- ▨ Site Location

MULTI-USE SPORTS FACILITY, OKLAHOMA CITY

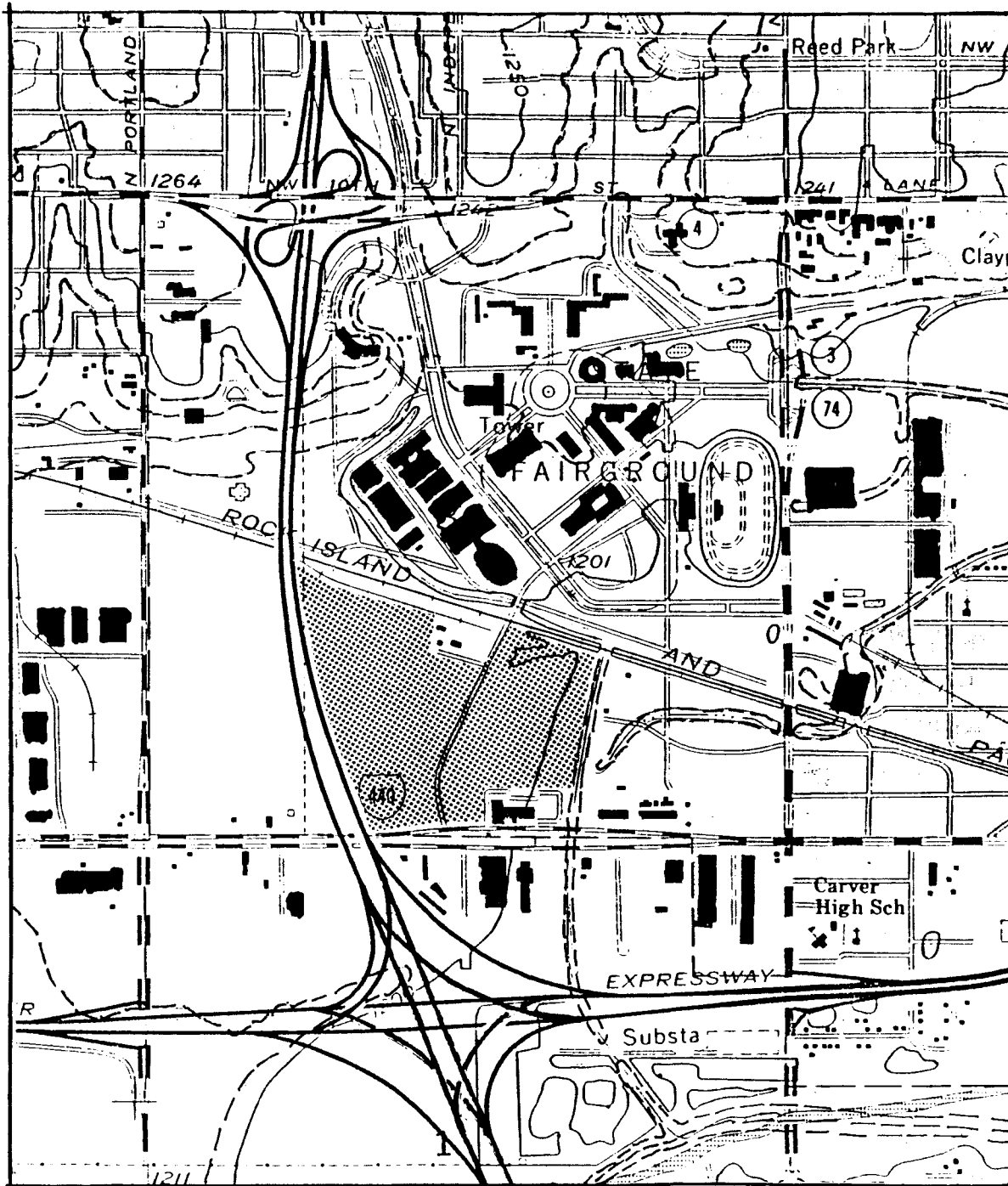

Contours

shown at 10' intervals

MULTI-USE SPORTS FACILITY, OKLAHOMA CITY

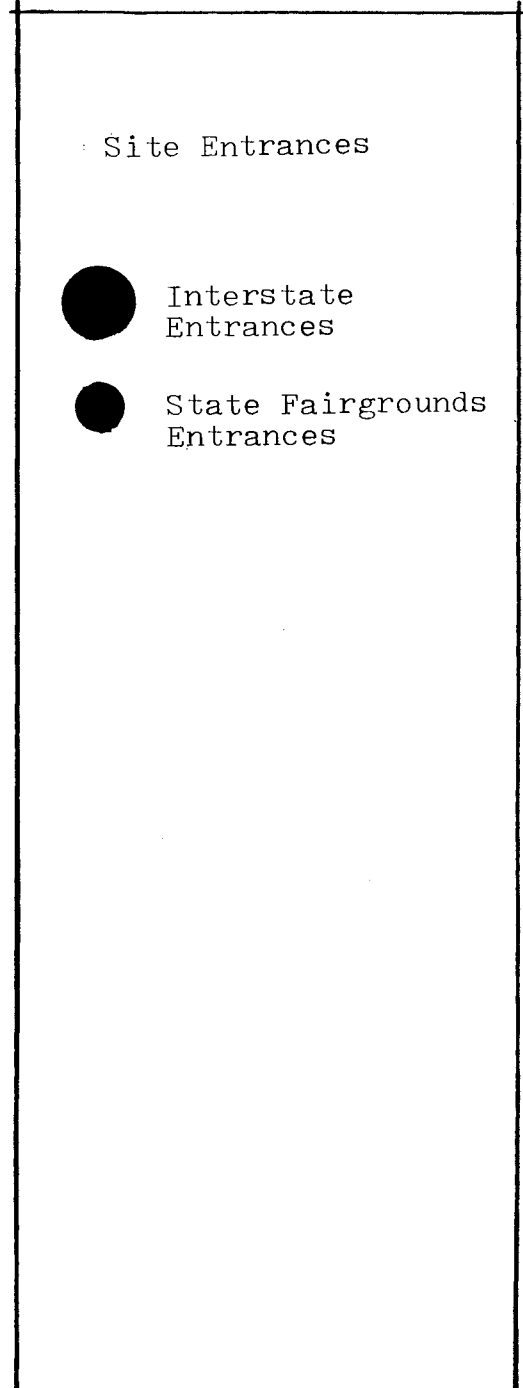
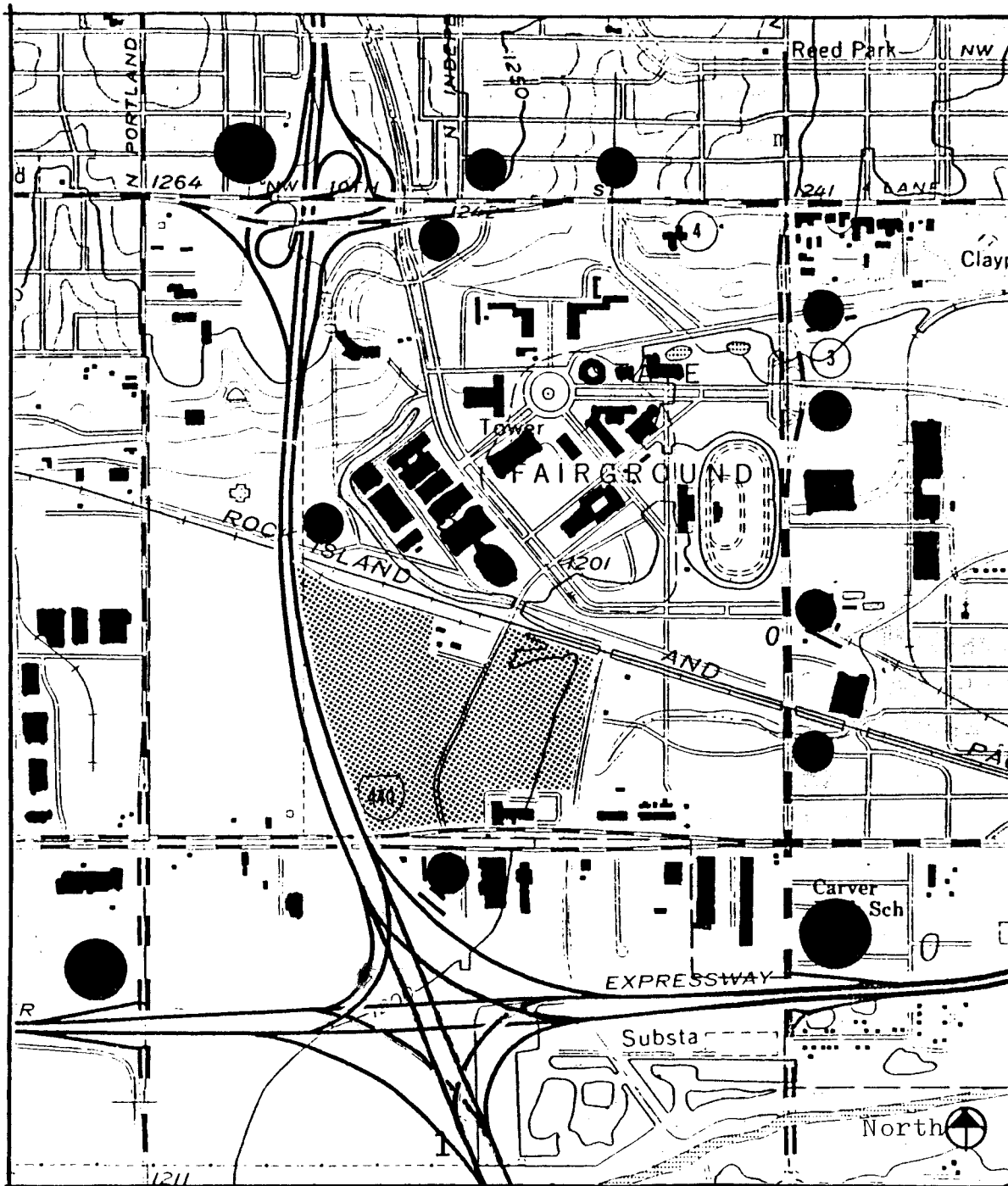

MULTI-USE SPORTS FACILITY, OKLAHOMA CITY

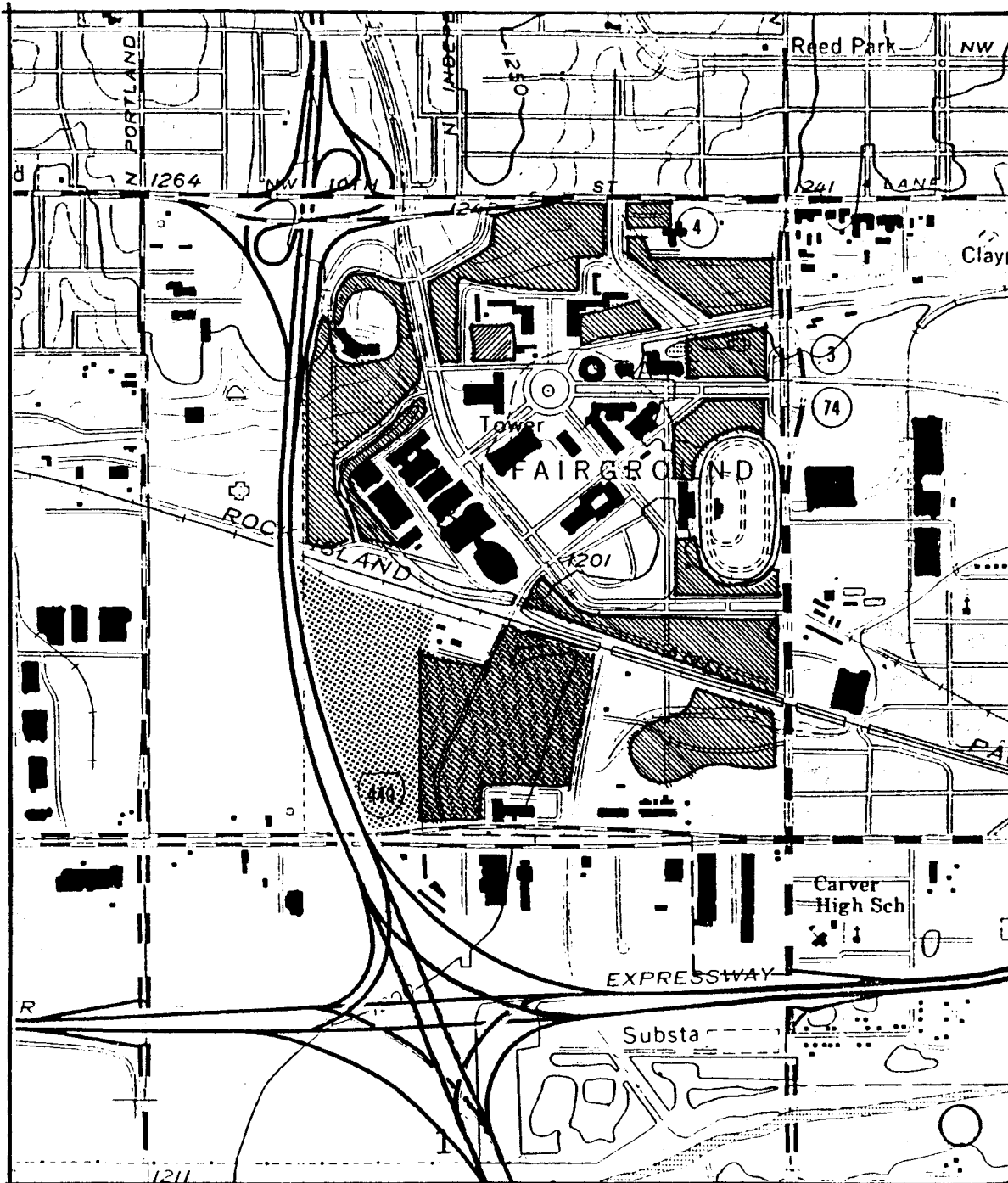

Existing Parking

 Parking

MULTI-USE SPORTS FACILITY, OKLAHOMA CITY

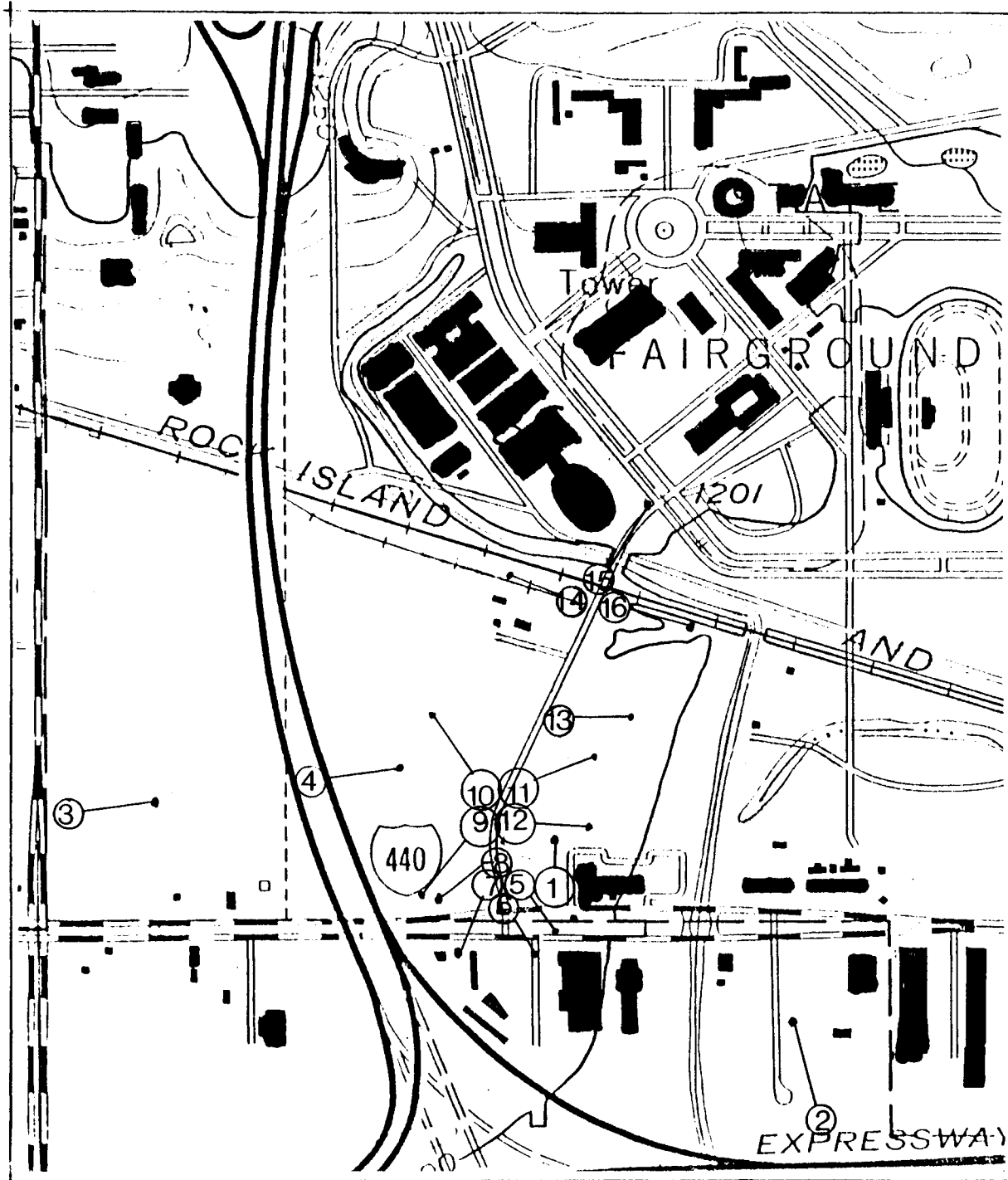

Photographic Survey

MULTI-USE SPORTS FACILITY, OKLAHOMA CITY

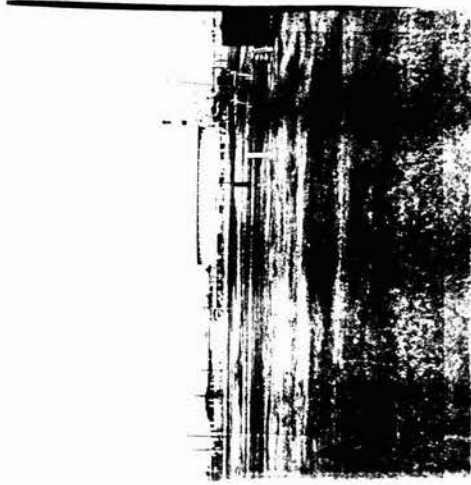

1



2

3



4

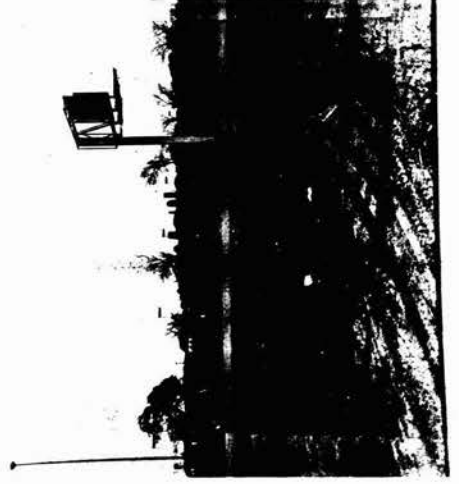



5

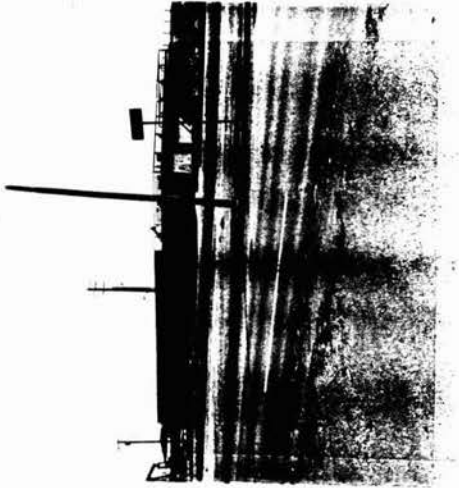

6

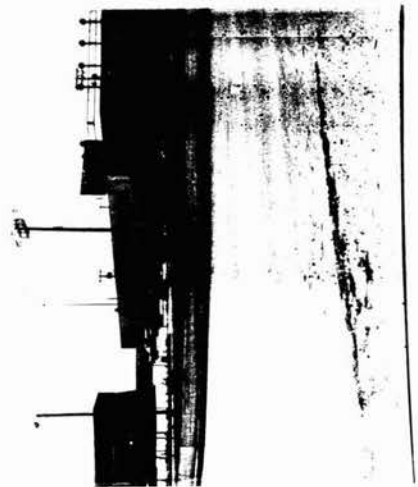

7

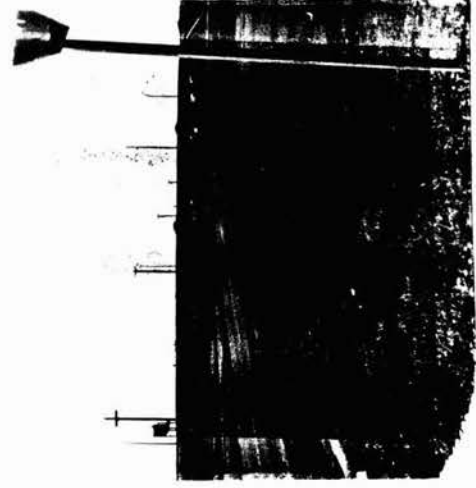

8

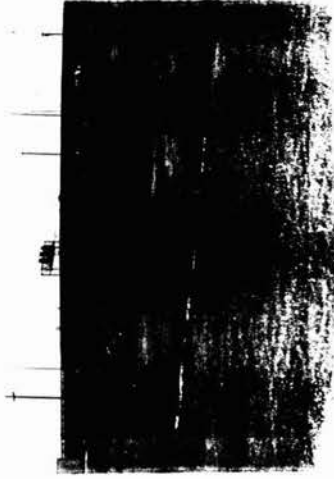

9



10

11



12



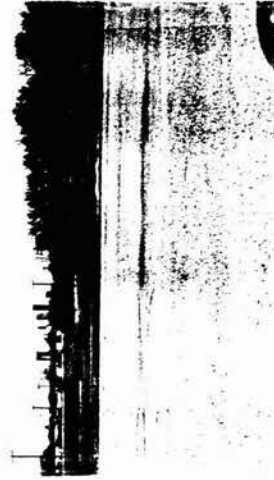

13



14



15

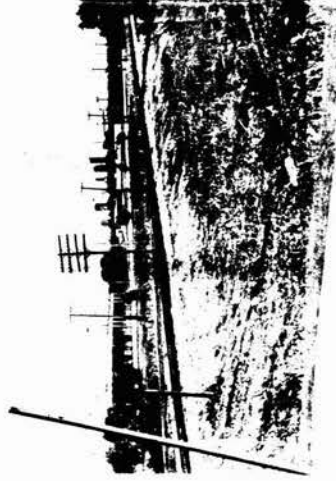

16

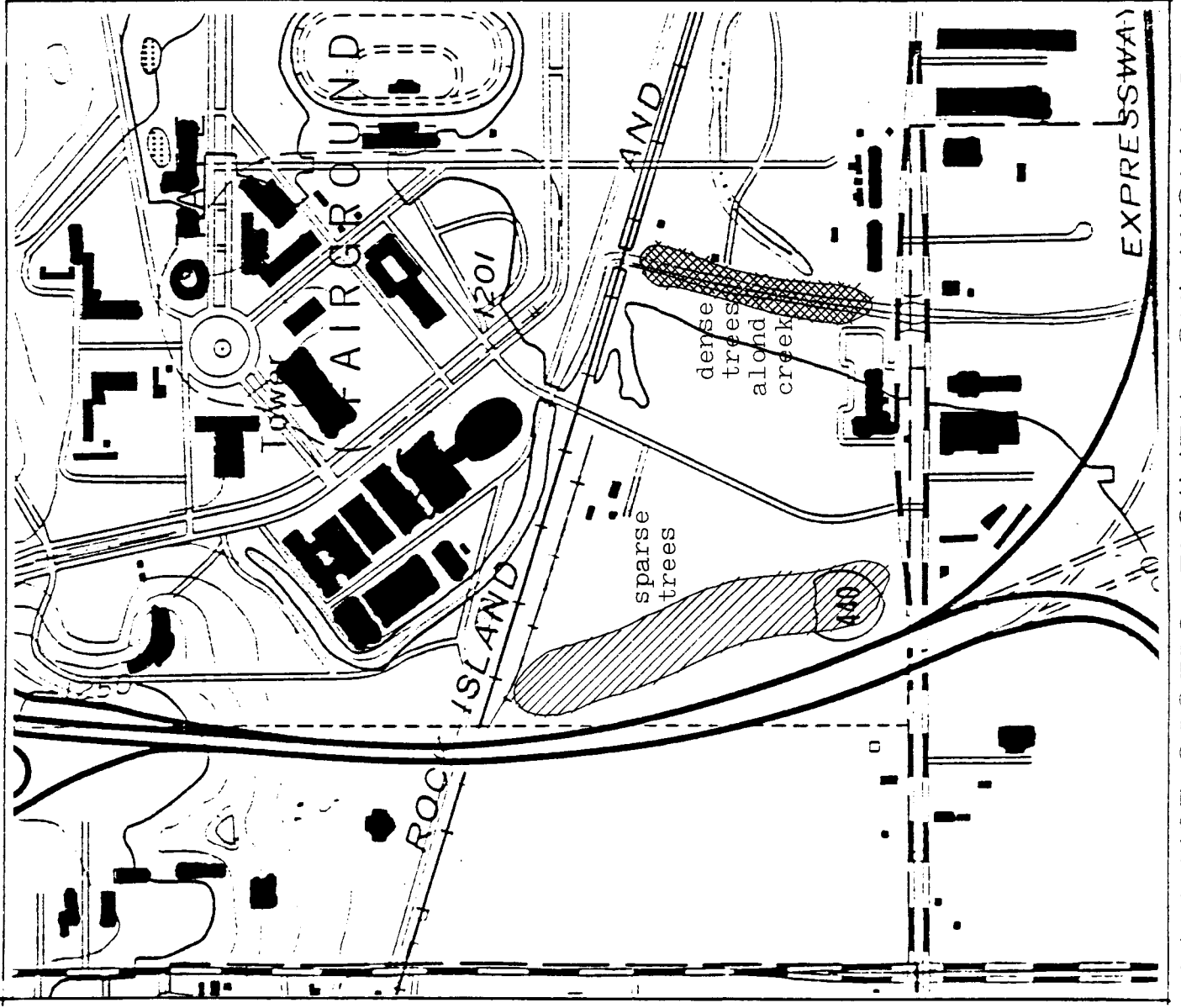

Vegetation

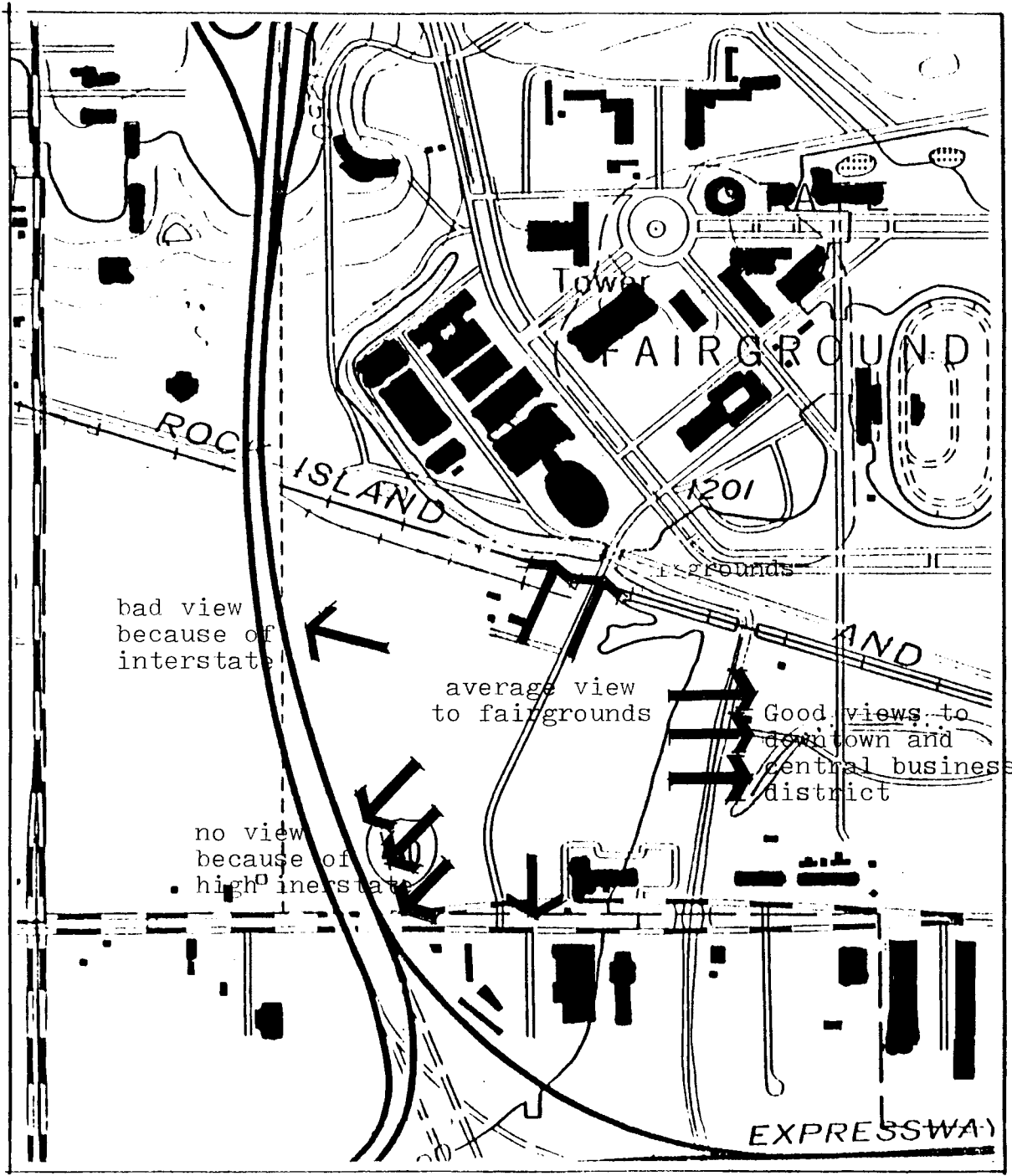

Views from Site

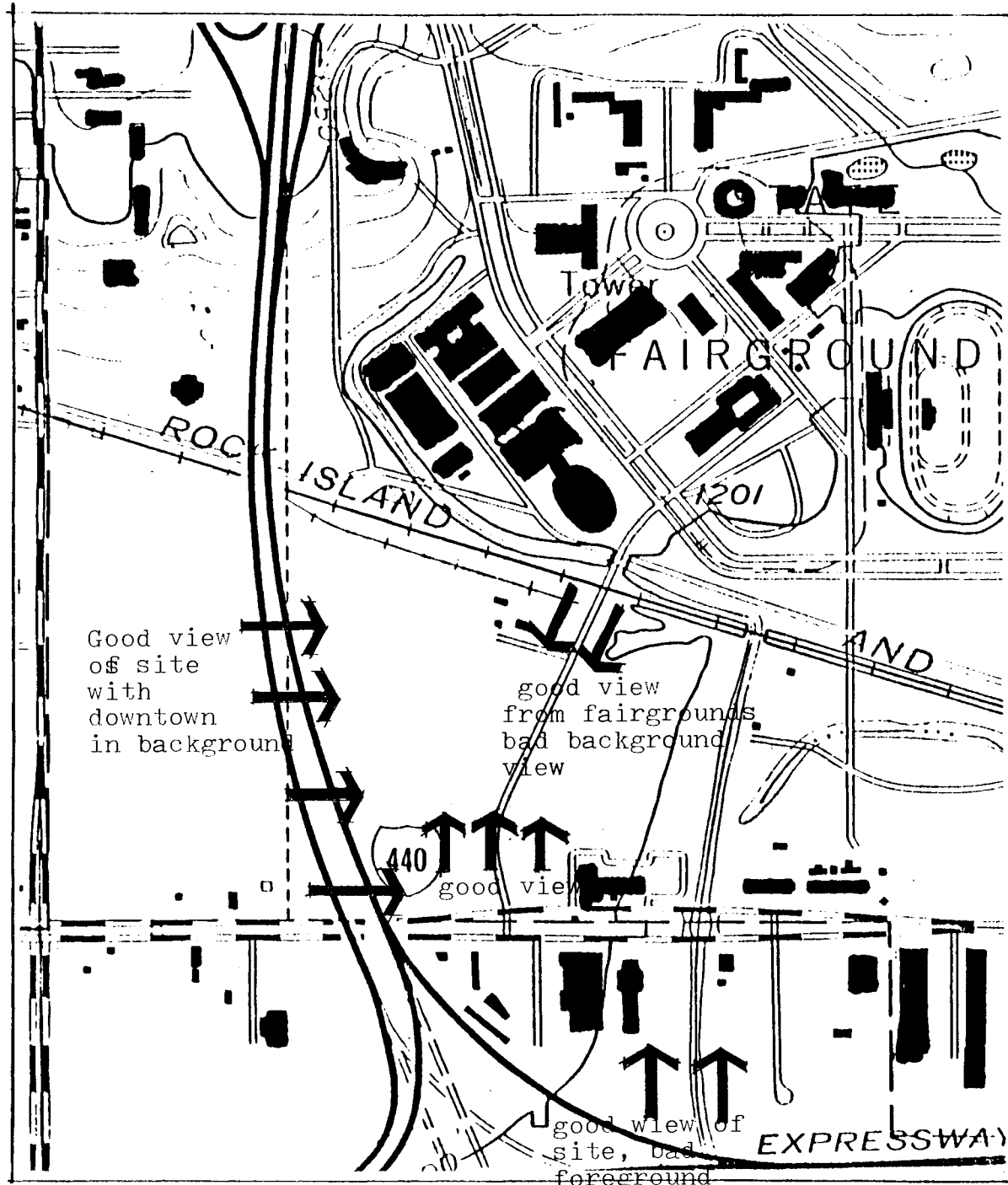

Views toward Site

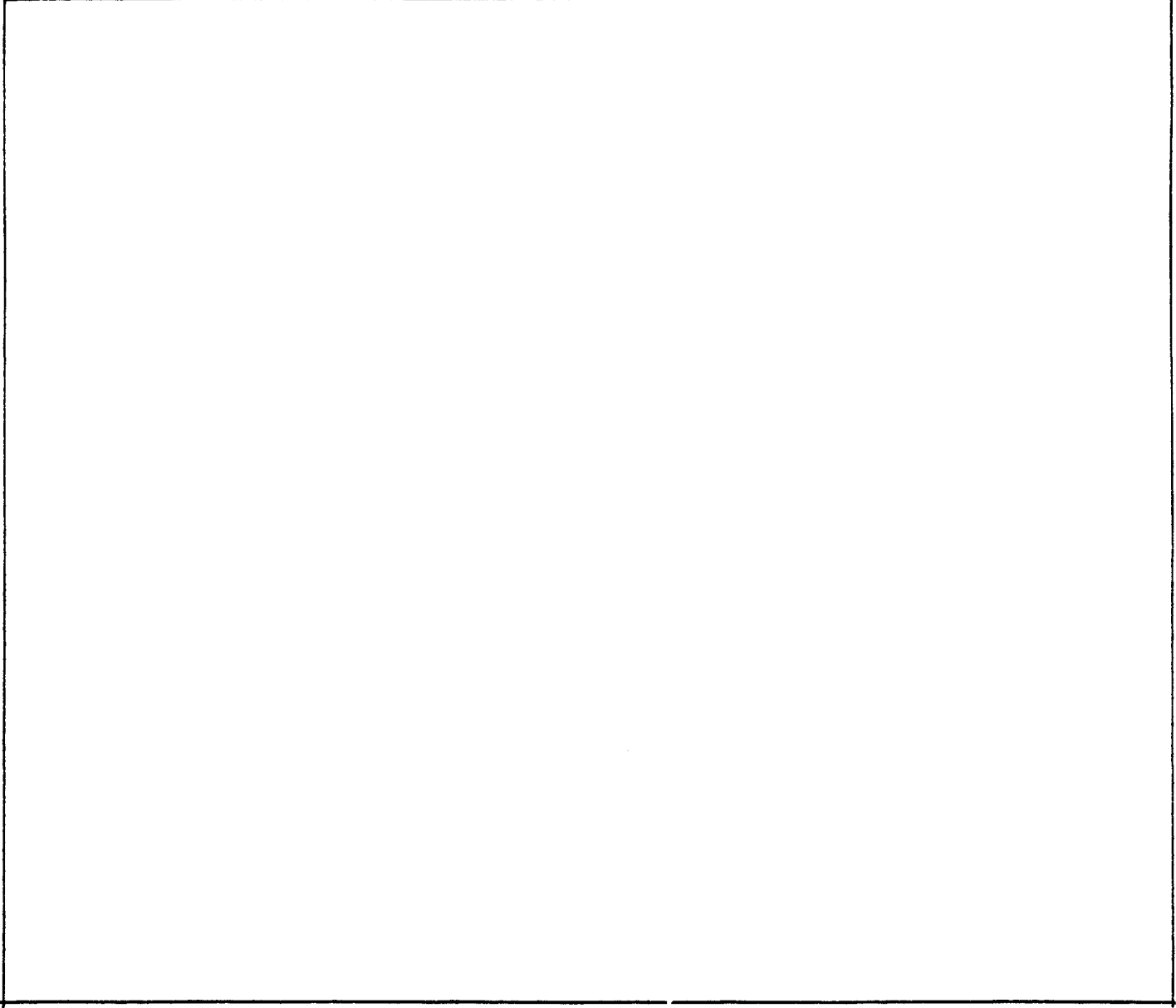
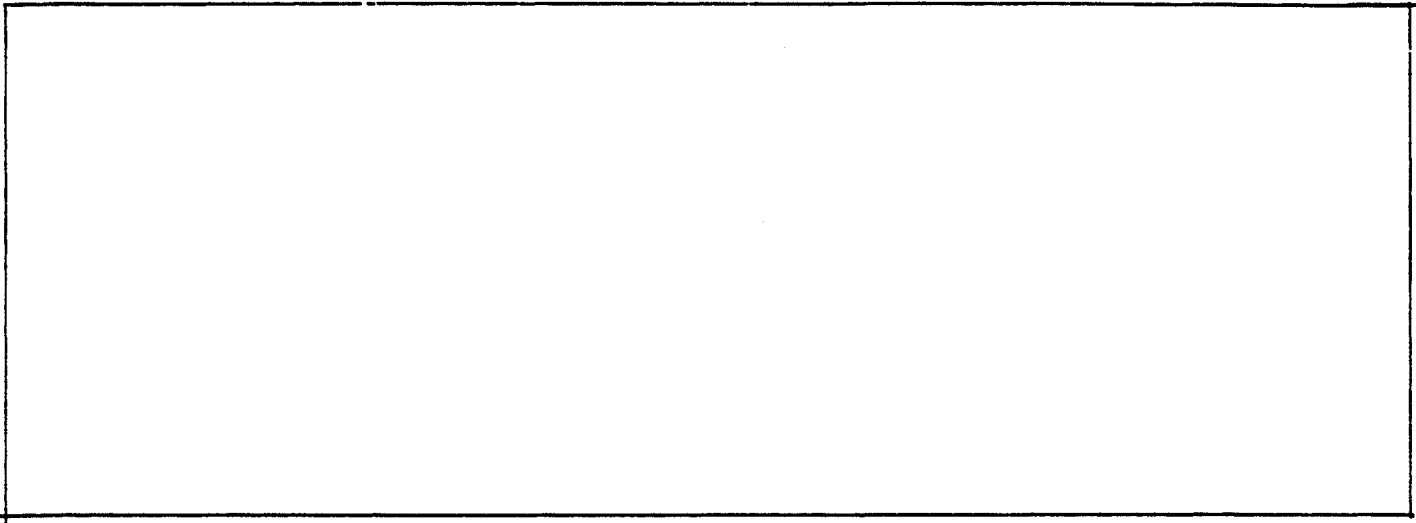

Types of Construction:

Construction Classification 401.0
Historic Buildings 516.0
Places of Public Assembly 617.0
Stadiums and Grandstands 617.0
Drive-in Motion Picture Theatres 620.0

Allowable Area:

General area Limitations 505.0
Area Exceptions 506.0
Subdivisions of Attic Spaces 1420.0
Unlimited Areas 507.0
Unlimited Areas, school buildings 507.1.1
Unlimited Area, Indoor Recreation 507.1.2

Allowable Height:

General Height Limitations 505.0
Height Exceptions 508.0

Fire Separations

Fire Walls and Party Walls 1407.0
Fire Separation Walls 1409.0
Elevator Opening Protectives 2112.0
Automatic Fire Doors and Dampers 1403.0
Mixed Use and Occupancy 312.0
Vertical Shafts 1410.0
Fireresistance Rated floor/roof
assemblies 1412.0

Exterior Wall Protection

Exterior Walls 1406.0
Exterior Opening Protectives 1414.0
Glazing of Unprotected Openings 2402.0

1981 BOCA Codes

Fire Limit Requirements:

Restrictions Within Fire Limits 502.0
Restrictions Outside Fire Limits 503.0
Roof Structures 1426.0

Fire Resistance:

Fire Hazard Classification 1402.0
Fire Resistance Tests 1403.0
Skylights 1426.3
Opening Protectives 1403.3
Fire-retardant treated wood 1403.5
Fire Resistance of Structural Members 1411.0
Fire Rated Floor/Roof Assemblies 1412.0
Roof Construction 1413.0
Fire Windows and Shutters 1416.0
Firestopping 1420.0
Balconies 1425.4
Roof Structures 1426.0
Roof Coverings 1427.0
Refuse Vaults, Enclosures Requirements 1608.0
Grade Floor Protection 1405.7

Interior Finish

Interior Finish and Trim 1421.0
Application of Interior Finish 1422.0
Flame Resistance Tests 1404.0
Decorative Material Restrictions 1424.0

Means of Egress

Occupant Load 806.0
Location 807.0
Capacity 808.0
Number of Exits 809.0

1981 BOCA Codes

Exit Access Corridors 810.0
Grade Passageways 811.0
Means of Egress Doorways 812.0
Horizontal Exits 814.0
Interior Exit Stairways 816.0
Access to Roof 817.0
Exit Signs 823.0
Means Of Egress Lighting 824.0
Elevator, Exit Restrictions 2109.0
Smokeproof Enclosures 818.0
Exterior Exit Stairways 819.0
Panic Hardware 812.5.4 617.0

Fire Protection Systems:

Water Sprinkler Systems 1704.0
Fire Suppression Systems 1702.0
Standpipe Systems 1711.0
Fire Department Connections 1713.0
Water Supply 1714.0
Manual Fire Alarm Systems 1717.0
Supervisions 1718.0

Vertical Openings:

Shafts 1410.0
Firestopping 1420.0
Vertical Shafts and Hoistways 1410.0
Hoistway Enclosures and venting 2108.0
Open Wells and Atriums 631.0

Hazardous Area:

Boiler and Equipment Rooms 711.0
Segregation of Storage Space 600.6
Existing Buildings 605.0
Pyroxylin Plastics 607.0
Inspection of Hazardous uses 603.1

1981 BOCA Codes

Light and Ventilation:

Bath and Toilet Rooms 711.0
Ventilation of Shafts 1410.0
Artificial Light and Ventilation 704.0
Natural Light and Ventilation 706.0
Air Conditioning, Refrigeration, and
Mechanical Ventilation (See Mechanical
Code Listed in Appendix A)
Skylights 2405.0

Sanitation:

Plumbing and Drainage article 22
Termite Protection 1317.0
Handicap Plumbing Fixtures 515.8

Electrical Wiring

See Article 20

Motion Picture Projection Rooms:

Use and Storage of Flammable Films 608.0
Projection Rooms, construction 608.3

Stages and Platforms:

Stage Construction 617.6
Dressing Rooms 617.7

Provisions For the Handicap and Aged:

Section 515.0

Energy Conservation:

Article 25

1981 BOCA Codes

SECTION 21: C-3 Commercial (General)

21.1 General Description

This Commercial district is intended for the activity of personal and business services and the general retail business of the community. Persons living in the community and in the surrounding trade territory require direct and frequent access. Traffic generated by the uses will be primarily passenger vehicles and only those trucks and commercial vehicles required for stocking and delivery of retail goods.

21.2 Permitted Uses

1. Any use permitted in the C-1 light Commercial District
2. Signs and Billboards
3. Auto Service Stations
4. Bakery (Commercial or Wholesale)
5. Bottling Works
6. Feed and Seed Stores
7. Food Processing (Retail on Premises)
8. Glass Fabrication and Installation
9. Laundry, Cleaning, and Dyeing Est.
10. Plumbing, Building, Electrical, and Mechanical Contractor Shops
11. Motel and Hotel
12. Metal Fabrication, Light (Sheet Metal, ducts, Gutters, Leaders)
13. Optical and Scientific Instruments, Jewelry, Manufacturing

21.2 Uses By Review:

1. Warehouse, Commercial- provided that the gross floor area of such warehouses shall not exceed forty percent (40%) of the total tract, lot, or parcel of land on which it is sit.
2. Any other similar business or service which is in keeping with the general description, and meets the three (3) standards as described in Sec. 31 (Conditions for Authorization).

21.4 Area Regulations:

- A. Front Yard Setback- Twenty-Five (25) feet, unless when fifty (50) percent or more of the lots on the same side of the street and between intersections have a fairly uniform front yard depth more or less than the required front yard depth, all buildings hereafter erected in any such block on the same side of the street shall be located so as to conform with such uniform depth.
- B. Rear Yard-none
- C. Side Yard-none
- D. Side Yard, Corner Lot- Twenty-Five (25) feet or same as existing structure on side street.

21.5 Height Regulations:

Thirty-Five (35) feet.)

Zoning Ordinances

Section 22: C-4 Commercial (Central Business District)

22.1 General Description

This district is designed to be the central business district or the downtown shopping and employment area for the community and surrounding area. This district is intended to provide space for retaining of all kinds, professional offices, financial institutions, transient residential facilities and limits wholesaling

22.2 Permitted Uses:

1. Any use permitted in a C-3 General Commercial District

22.3 Uses by Review:

1. Light Manufacturing.
2. Warehouse, General.

22.4 Area Regulations:

- A. Front Yard- none
- B. Side Yard- none
- C. Rear Yard- none

Zoning Ordinances

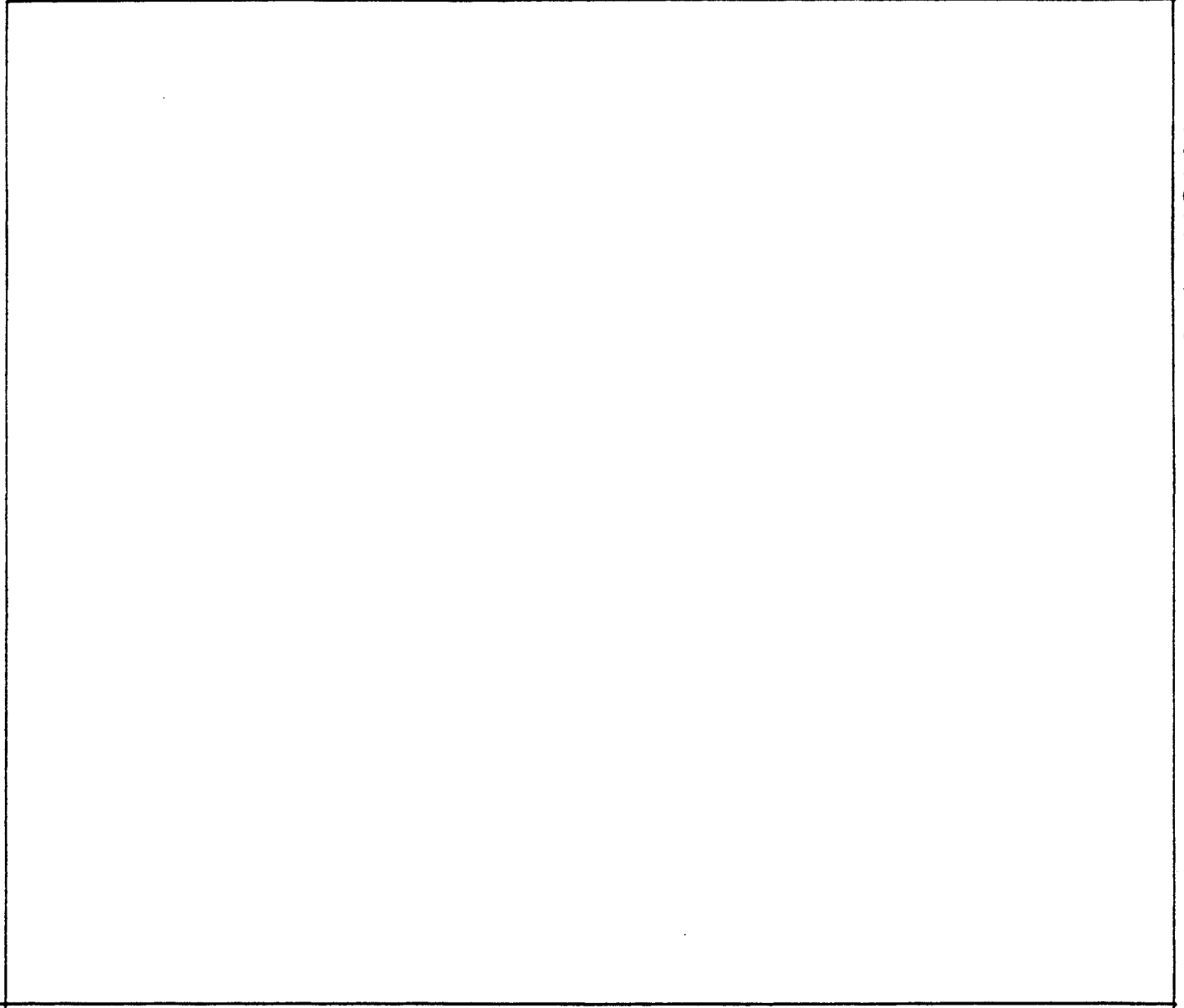
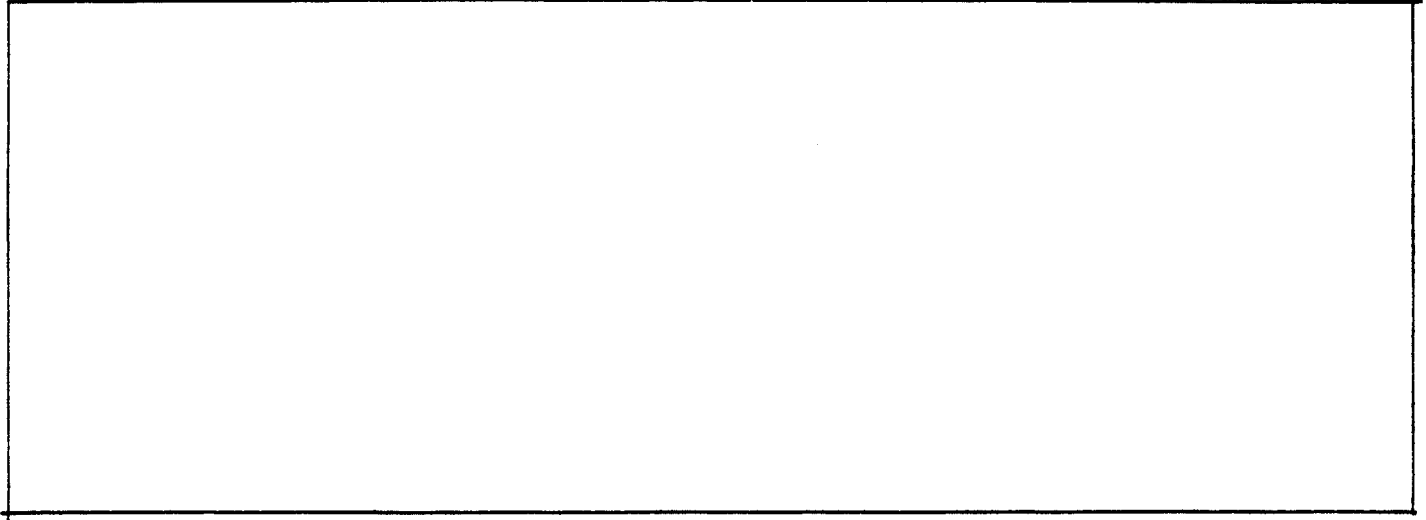

Seating Area

The seating area is one of the most important areas in a stadium complex. It is an assembly place for thousands of people during a game or event. The function of this space is to provide good viewing quality for the spectators to see the game while after the game it should allow people to leave this space as soon as possible. (The Life Safety Code has the requirements for different sizes of stadiums.

To achieve these two major functions the designer should concentrate his effort to deal with the slope of the seating area, the circulation, and the access of this area.

Other functions of this space such as illumination, color, noise control, and ventilation should also be considered carefully.

The size of a sports facility, a field house, a gymnasium or even a large football stadium mainly depends on its seating capacity, because the playing field is relatively constant in size, no matter how large the sports facility seating will be.

The Viewing Quality From the Seats

There are several facets that effect the view of people who sit around the playing field:

1. The feeling of Clearness:
It depends upon
 - A. The distance between the spectator and the player, the closer the better.

- B. The intensity of light.
- C. The contrast of colors of the surrounding surface to the player.

2. The feeling of depth:
It is the feeling of the spectator recognizing the objects which are in front or behind the player. It also depends on the above A, B, and C facets plus another facet which is the sight angle of the spectator. In other words that is the height of the seat above the playing grounds.
3. The feeling of heightness:
It is the feeling of the spectator to recognize the objects which are above or below the player. It depends on the same facts which effect the feeling of depth.
4. Orientational Effect:
The seats located closer to the short axis to the playing field or grounds the better.

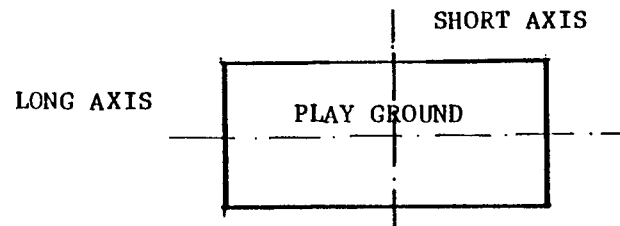

Typical Dimensions of Seating

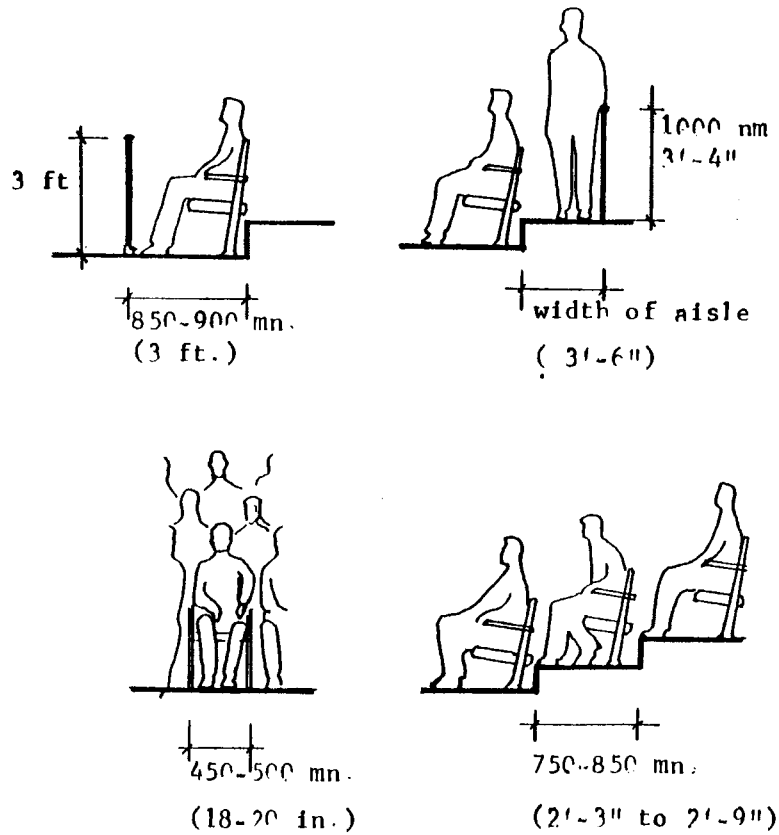

EVELUATION OF THE VIEWING QUALITY FROM THE SEATING AREA

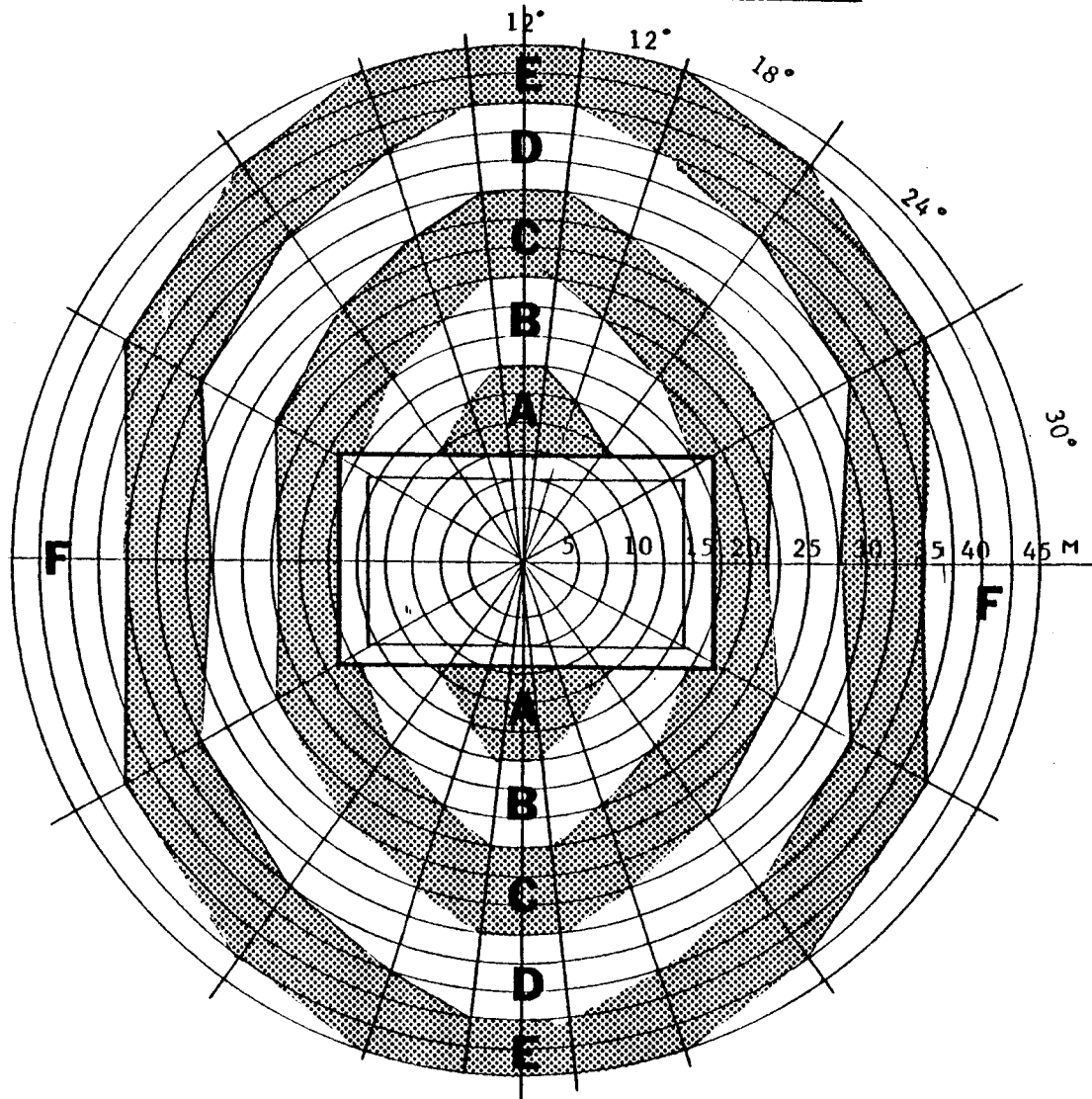

ZONE	
A	EXCELLENT
B	GOOD
C	SATISFY
D	ACCEPTABLE
E	NOT GOOD
F	BAD

Seating Slope

There are several methods to determine the slope of the seating area. In order to provide better viewing from the seats the slope of the seating area has to be a curved line according to the calculations. But for easy construction and economy sometimes a straight slope is commonly used. The following are different kinds of slope which are used in the seating area.

1. Straight Slope: It has the same height of each riser often used in small gymnasiums. It can be built with steel structures system and concrete structures. Most of the moveable bleachers have this type of straight slope. It is easy for construction and very economical.

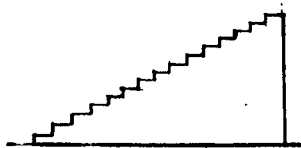

2. Curved Slope: It has different height of the risers, the seats closer to the playing ground the lower the height of the riser. It is difficult for construction than the straight slope, but it will provide better viewing from the seats. It is suitable for large stadiums.

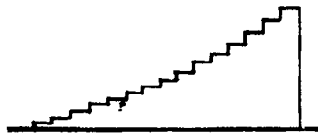

3. Tangential Slope: This type of structure takes the advantages of both straight slope and the curved slope structures. It is more easy to construct than the curved slope structures and is easier to build.



There are several methods to determine the slope of the seating areas. First of all is the "graphic method". By using this method we can find the curved line which will be the curved slope of the seating area. It can be used in schematic design. It is simple, but not accurate enough for working drawings and for construction purposes.

If we want to find out the exact height of each riser which we need. It is more proper to use certain formula and table chart than the "graphic method". By using these formula and table chart, we can calculate the height of each riser for either straight slope, tangential slope or for curved slope.

The following pages show these methods.

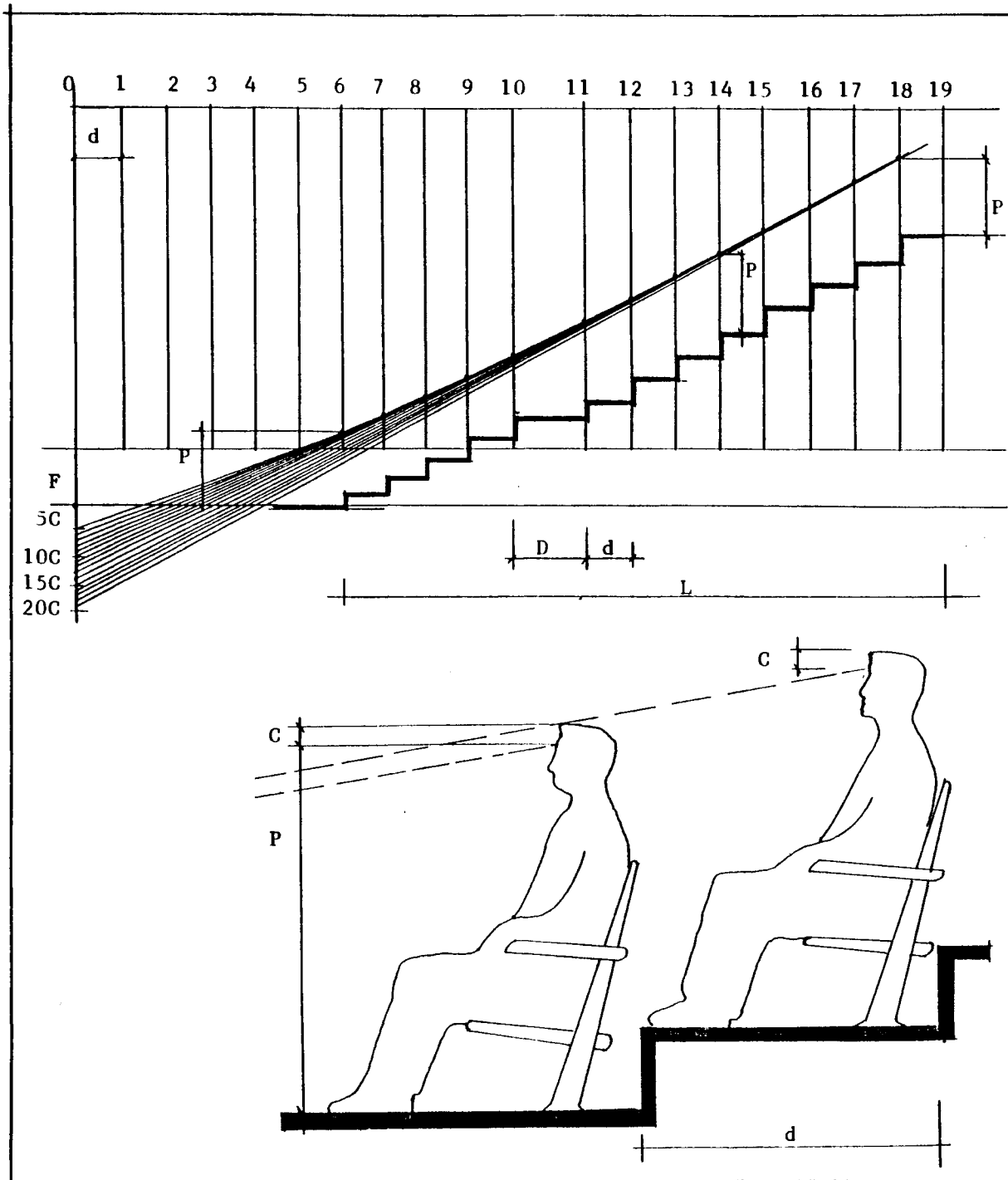

The above drawing shows the "graphic method" to determine the slope of the seating area.

$C=120$ mn. (5 in.)

$P=1,200$ mn. (4 feet)

$d=750-850$ mn. (2'-3" to 2'-6")

$D=1,200$ mn. (3'-8" aisle)

F- the edge of basketball court floor or 30 cm. above floor.

Seating Capacity

The following table shows the seating capacity which is based on 18 in. seats. Effects of Aisle: The normal aisle width of 36 in. has the effect of reducing the seating capacity by 2 seats per row x the number of rows x the number of aisle.

Number of Rows.

	3	4	5	6	7	8	9	10	11	12	13	14	15	16	17	18	19	20	21	22	23	24	25	26
16	21	26	32	37	43	48	53	58	64	69	74	80	85	90	96	101	106	112	117	122	128	133	139	
24	32	40	48	56	64	72	80	89	96	104	112	120	128	136	144	152	160	168	176	184	192	200	208	
32	42	53	64	74	85	96	106	117	128	138	149	160	170	181	192	202	213	224	234	245	256	267	277	
36	48	60	72	84	96	108	120	132	144	156	168	180	192	204	216	228	240	252	264	276	288	300	312	
40	53	66	80	93	106	120	133	146	160	173	186	200	213	226	240	253	266	280	293	306	320	333	347	
48	64	80	96	112	128	144	160	176	192	208	224	240	256	272	288	304	320	336	352	368	384	400	416	
56	74	93	112	130	149	168	186	205	224	242	261	280	298	317	336	354	373	392	410	429	448	467	485	
60	80	100	120	140	160	180	200	220	240	260	280	300	320	340	360	380	400	420	440	460	480	500	520	
64	85	106	128	149	170	192	213	234	256	277	298	320	341	362	384	405	426	448	469	490	512	533	555	
72	96	120	144	168	192	216	240	264	288	312	336	360	384	408	432	456	480	504	528	552	576	600	624	
80	106	133	160	186	213	240	268	293	320	346	373	400	426	453	480	506	533	560	586	613	640	667	693	
84	112	140	168	196	224	252	280	308	336	364	392	420	448	476	504	532	560	588	616	644	672	700	728	
88	117	146	176	205	234	264	293	322	352	381	410	440	469	498	528	557	586	616	645	674	704	733	763	
96	126	160	192	224	256	288	320	352	384	416	448	480	512	544	576	608	640	672	704	736	768	800	832	
104	136	173	208	242	276	312	346	381	416	450	485	520	554	589	624	658	693	728	762	797	832	867	901	
108	144	180	216	252	288	324	360	396	432	468	504	540	576	612	648	684	720	756	792	828	864	900	936	
112	149	186	224	261	298	336	373	410	448	485	522	560	597	634	672	709	746	784	821	858	896	933	971	
120	160	200	240	280	320	360	400	440	480	520	560	600	640	680	720	760	800	840	880	920	960	1000	1040	
128	170	213	256	298	341	384	426	469	512	554	597	640	682	725	768	810	853	895	938	981	1024	1067	1109	
136	176	220	264	308	352	396	440	484	528	572	616	660	704	748	792	836	880	924	968	1012	1056	1100	1144	
144	181	226	272	317	362	408	453	498	544	589	634	680	725	770	816	861	906	951	997	1042	1088	1133	1179	
152	192	240	288	336	384	432	480	528	576	624	672	720	768	816	864	912	960	1008	1056	1104	1152	1200	1248	
160	202	253	304	354	403	456	506	557	608	658	709	760	810	861	912	962	1013	1064	1114	1165	1216	1267	1317	
170	209	260	312	364	416	468	520	572	624	676	728	780	832	884	936	988	1040	1092	1144	1196	1248	1300	1352	
180	219	266	320	373	426	480	533	586	640	693	748	800	853	906	960	1013	1066	1120	1173	1226	1280	1333	1387	
184	224	280	336	391	448	504	560	616	672	728	783	840	896	962	1008	1064	1120	1176	1232	1288	1344	1400	1456	
188	234	293	352	410	469	528	586	645	704	762	821	880	938	997	1056	1114	1173	1232	1290	1349	1406	1467	1525	
192	240	300	360	420	480	540	600	660	720	780	840	900	960	1020	1080	1140	1200	1260	1320	1380	1440	1500	1560	
196	245	306	368	429	490	552	613	674	736	797	858	920	981	1041	1104	1165	1226	1288	1349	1410	1472	1533	1595	
200	256	320	384	448	512	576	640	704	768	832	896	960	1024	1088	1152	1216	1280	1344	1408	1472	1536	1600	1664	
204	266	333	400	466	533	600	666	733	800	866	933	1000	1066	1133	1200	1266	1333	1400	1466	1533	1600	1667	1733	

For example to use the above table counting the seating capacity.

3 aisles in a 15 row section of seating. 80'-00" long.

(2 seats x 15 row = 30 seats x 3 aisles = 90 seats)

80' of 15 row See above chart = 800 seats

SEATS LOST THROUGH AISLES = 90 seats

SEATING WITH 3 AISLES = 710 seats

The Arrangement of Seating Areas: the drawings on the right show different forms and arrangements of the seating area.

A-D small hall
E-H medium hall
I-O large hall



a

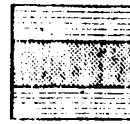

b

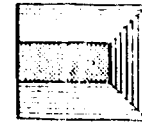

c

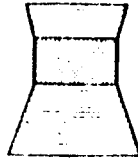

d



e

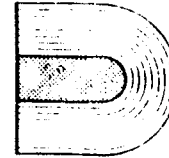

f

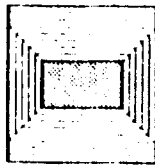

g

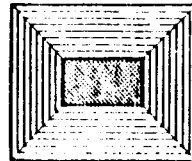

h

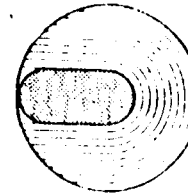

i

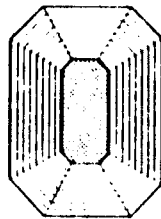

j

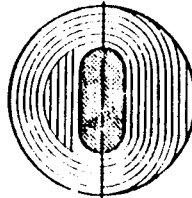

k

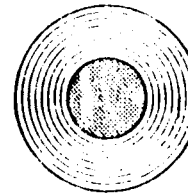

l

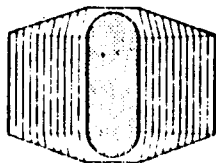

m

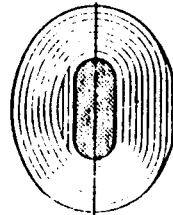

n

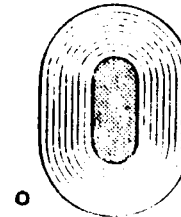

o

Circulation in the Seating Area

The arrangement of aisles and access for the seating areas:

In a large athletic facility, it might be thousands of people in the spectators seating area. In the proposal of the sports facility, it will have approximately capacity of 55,000-70,000 persons seating area. After the game or in an emergency situation, the circulation should provide enough accesses to let the people get out of the building as soon as possible. It is very important to arrange the aisles and accesses to lead people out of the building in a certain time limit. (The time limit is according to the Fire Protection Code and the Life Safety Code).

The maximum travel distances are required by the Life Safety Code. (which will be discussed later)

The following table shows the reference of the required time limit.

people time	under 1,200	1,201 to 2,000	2,001 to 5,000	5,001 to 10,000	10,001 to 50,000	50,001 to 100,000
outdoor (min.)	4	5	6	6	—	—
indoor (min.)	4	5	6	8	10	12

Types of Circulation in Seating Areas

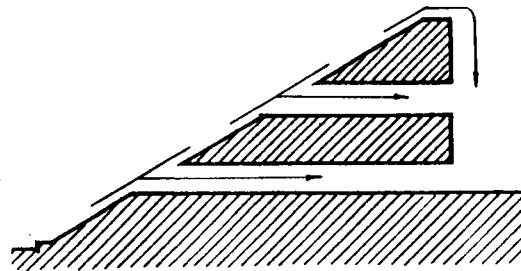
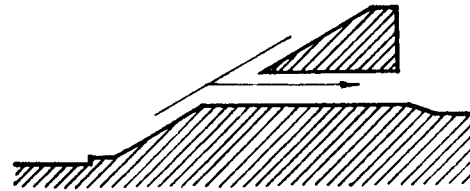
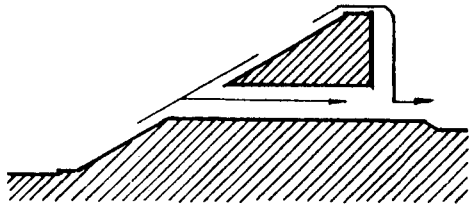
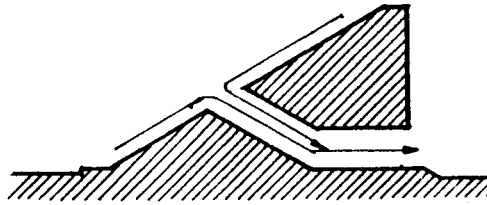
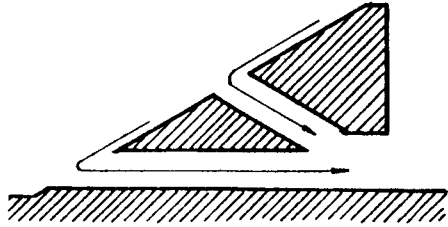

ARRANGEMENT OF ACCESSES IN SEATING AREA (plan)

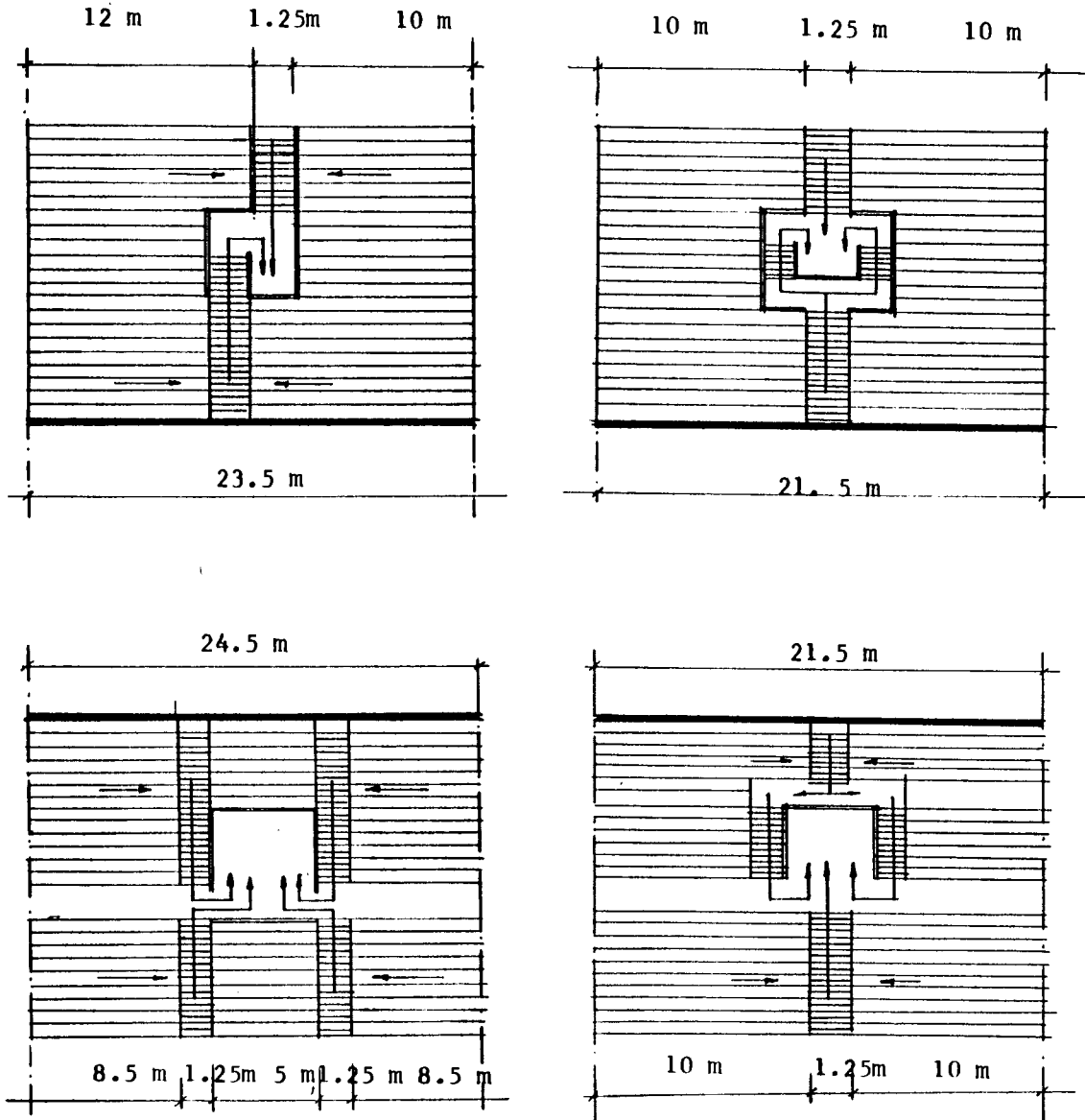

Locker Room Facilities

Stationary benches
 Mirrors for both boys and girls.
 Shelves below mirrors for girls.
 Full length mirror for girls.
 Drinking Fountain
 Bulletin board
 Lighting located so that aisles and passages are well illuminated.
 Windows located with regard to height and arrangement of lockers.

Rule of thumb area for locker rooms: (school, gymnasium, and community recreation buildings) 14 s.f. per person (peak period load) exclusive of locker space.

MINIMUM AISLE SPACE FOR DRESSING ROOMS

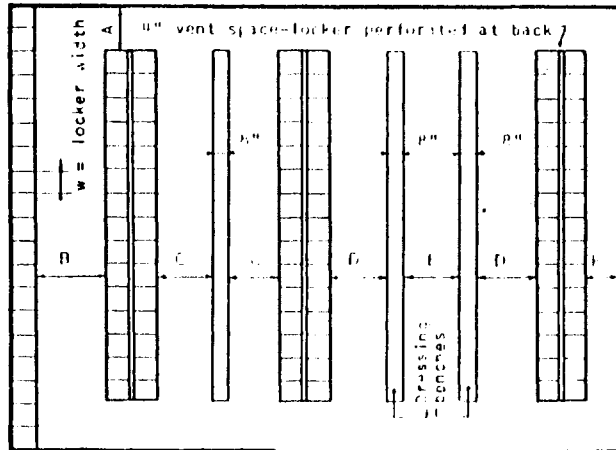

	SCHOOLS	AVERAGE TRAFFIC
A	2'-0"	2'-0"
B	2W + 12"	2W + 12"
C	2'- 6"	W + 6"
D	2'- 6"	W + 6"
E	2'- 6"	1'-8"
F	2'-6"	W + 12"

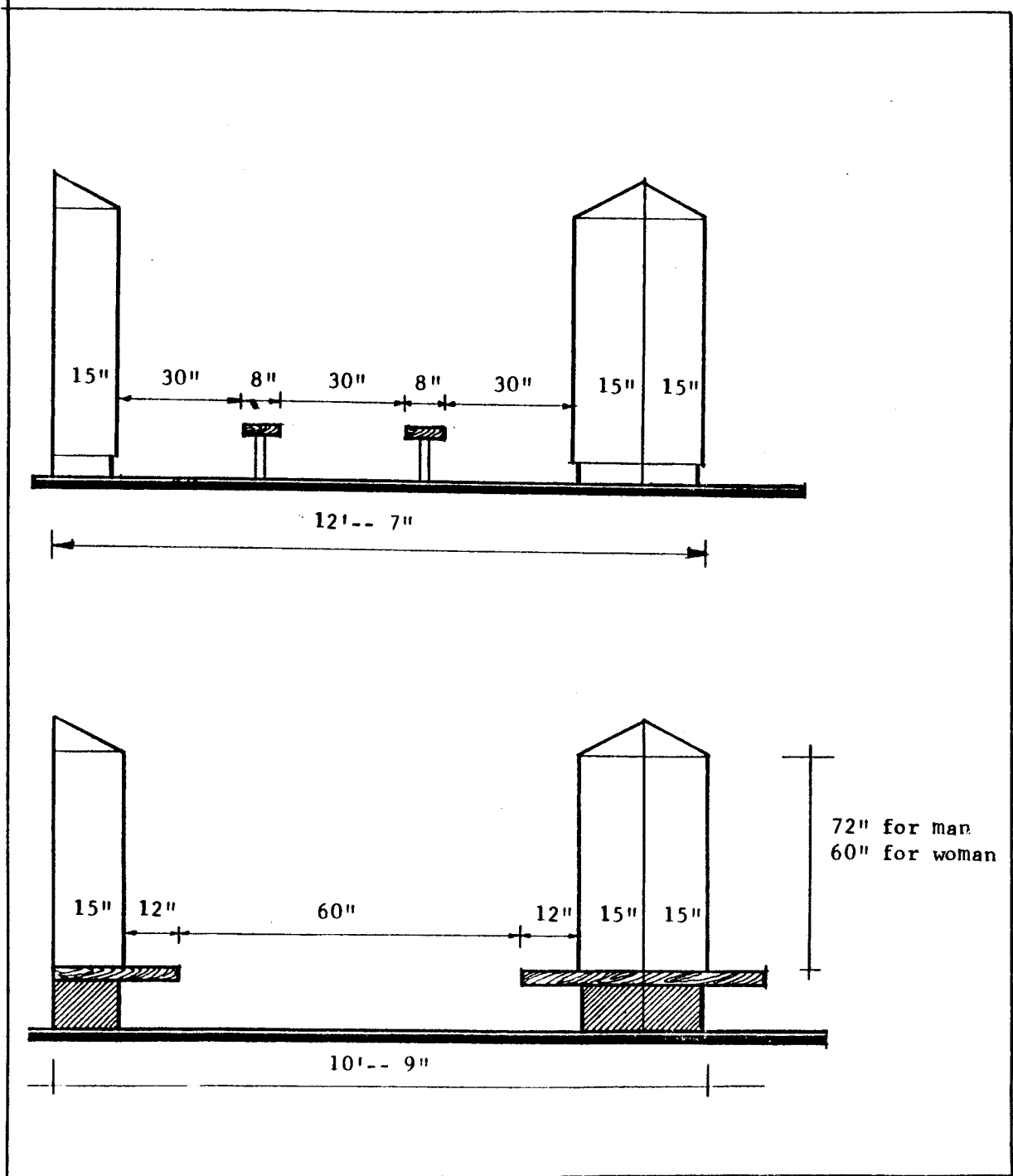

MULTI-USE SPORTS FACILITY, OKLAHOMA CITY

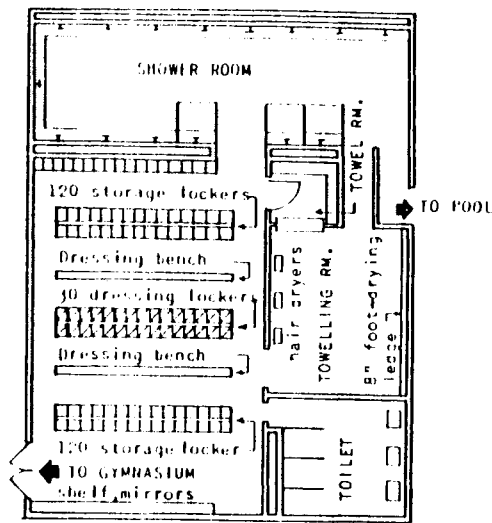

GIRLS' LOCKER SUITE

(Serves peak period load of 30)

Scale: 1/16" = 1'-0"

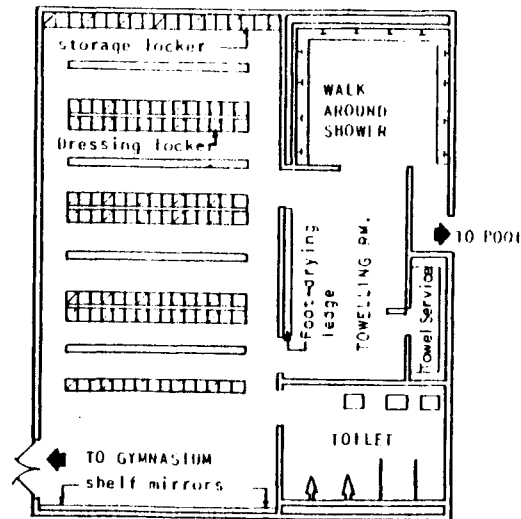

BOYS' LOCKER SUITE

(Serves peak period load of 40)

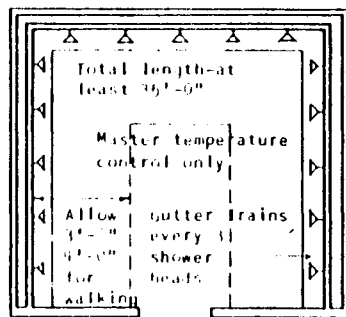

BOYS' WALK-AROUND SHOWER

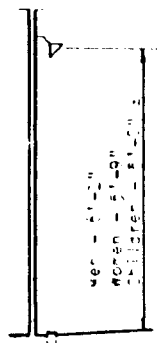

HEIGHT OF SHOWER HEAD

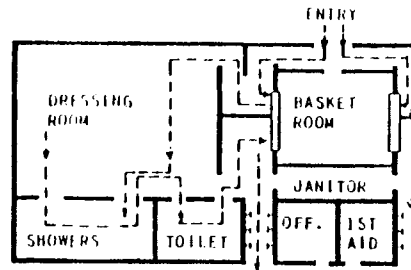

DRESSING UNIT FOR POOL

SHOWER ROOM	MS
TOWELLING ROOMS	ROOMS
DRESSING ROOMS	ROOMS

DRESSING UNITS FOR COMMUNITY USE

RECOMMENDATIONS FOR SHOWERING FACILITIES		
BLDG. TYPE	NUMBER OF SHOWERS	TYPE
School gymnasium	Girls - 40% of peak period load + 1 to 3 individual showers Boys - 30% of peak period load. Can be reduced by 1/3 for walk-around type	Gang & individual Gang & walk-around
Bythouses	Women-1 shower for each 250 women using pool. Men-1 shower for each 250 men using pool	Individual Gang
Community recreation buildings	Minimum for women-6 gang + 4 individual Minimum of 12 for men	Gang & individual Gang

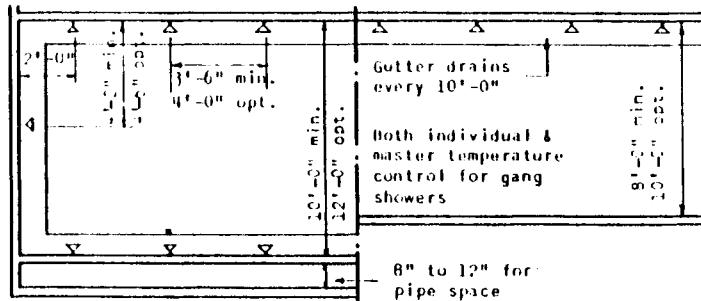

SHOWERS ON 2 WALLS SHOWERS ON 1 WALL
GANG SHOWERS

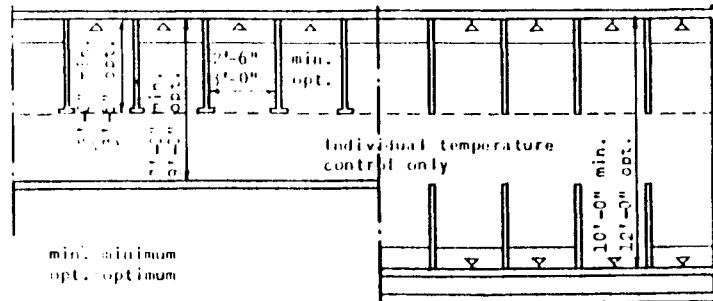

SHOWERS ON 1 WALL SHOWERS ON 2 WALLS
INDIVIDUAL SHOWERS

Training Room Facilities

Ideally the training room should be functional enough to serve both athletes and other purposes, such as first aid rooms or a class room resource for the training of athletic trainers.

The training facility should provide functional space for a doctor and trainers to serve the athletic program. The training room should not be a part of the dressing room but should be directly accessible from it.

A central location is important for the efficiency and effectiveness of a training area. It is desirable that the location be next to the dressing quarters, and for the ease of ambulance access.

Finishing Materials:

Floor: Material which is easily cleaned, water resistant and which will not be permanently discolored by solutions used in training areas. Commonly it is made of materials such as asphalt tile or synthetic floor materials.

Walls: Washable, moisture resistant paint.

Ceiling: Should be 10 feet high.

Light: 40-60 footcandles of artificial light

Typical Plan for Training Facility:

1. Training area: 50-60' x 25-30' x 10'
2. Adjacent Office:
3. Storage: 120 s.f. for medicine storage.

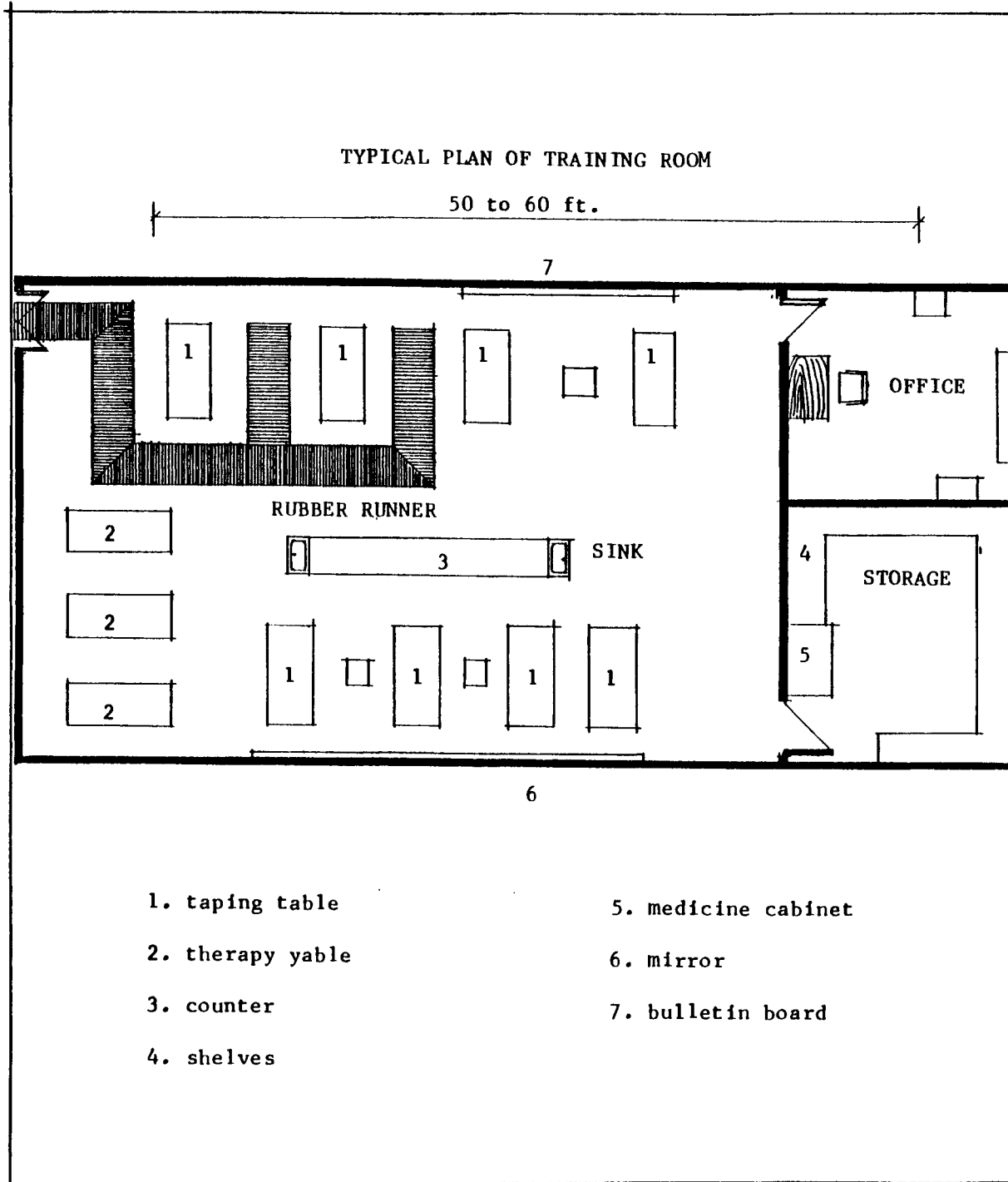

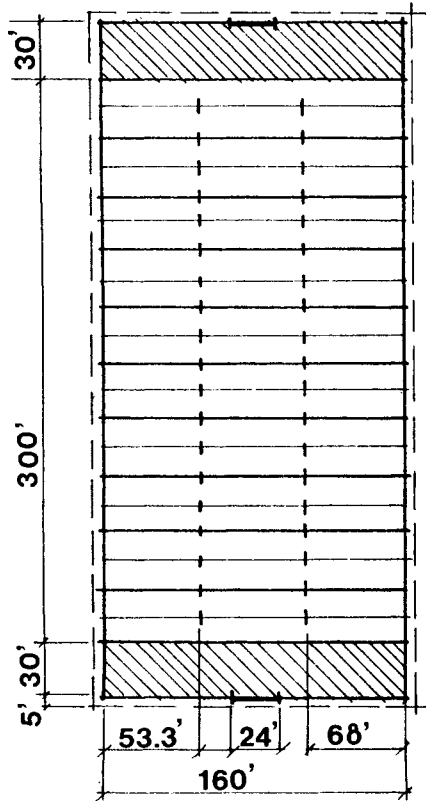

Football

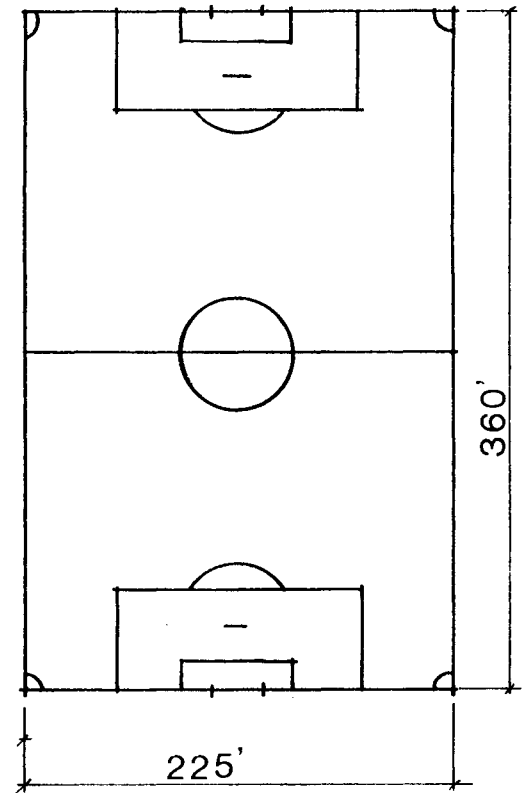

Soccer

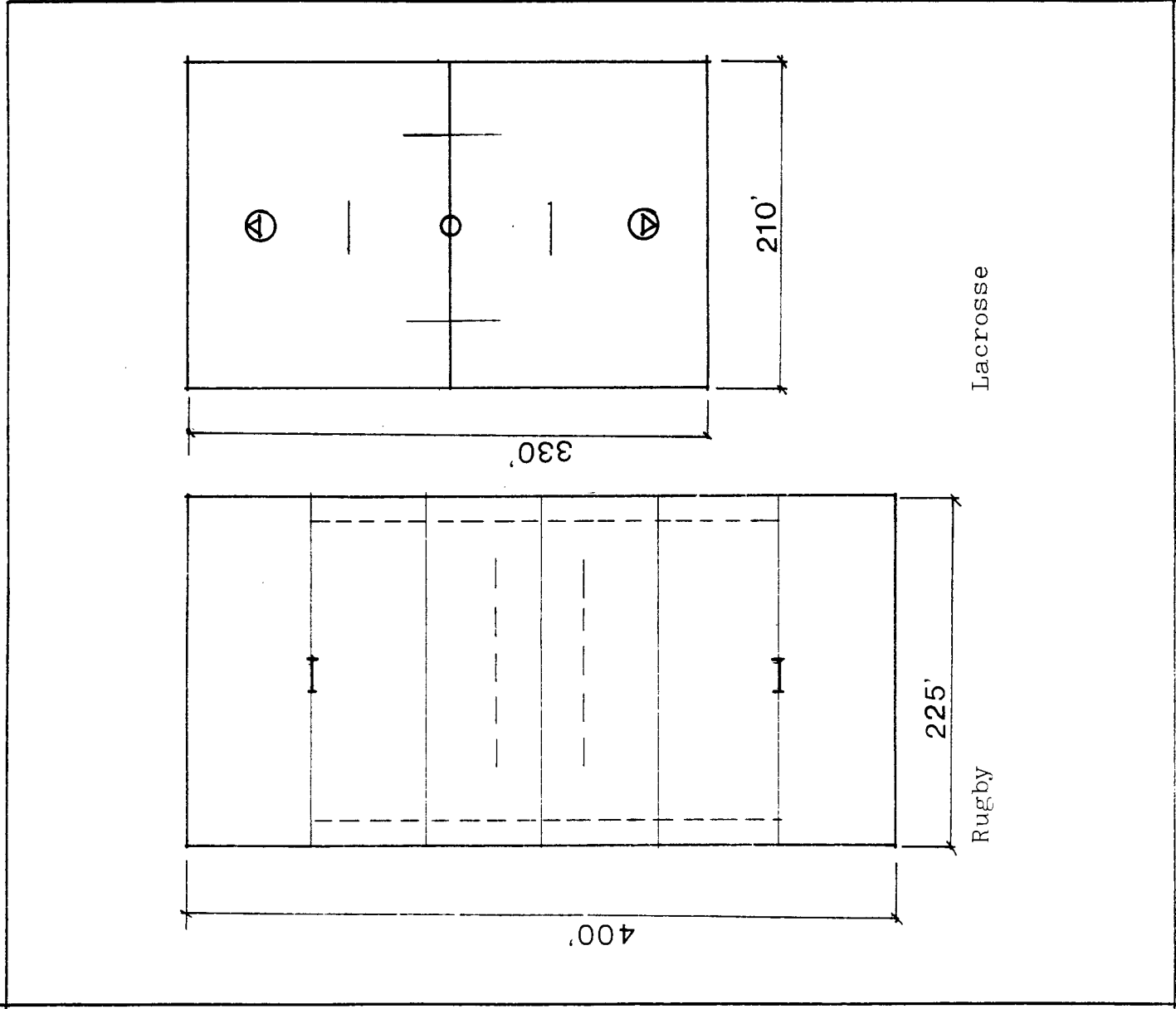
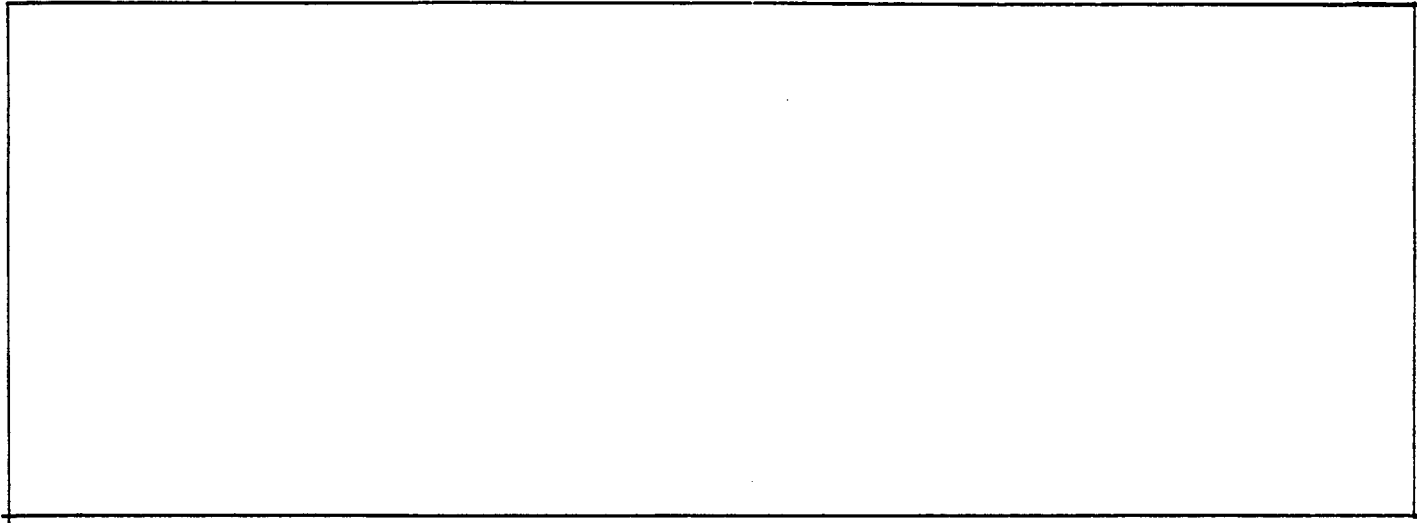

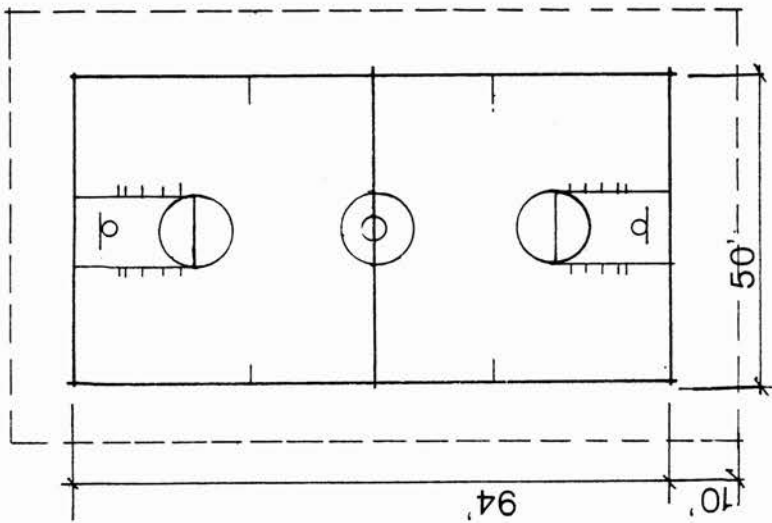

Basketball

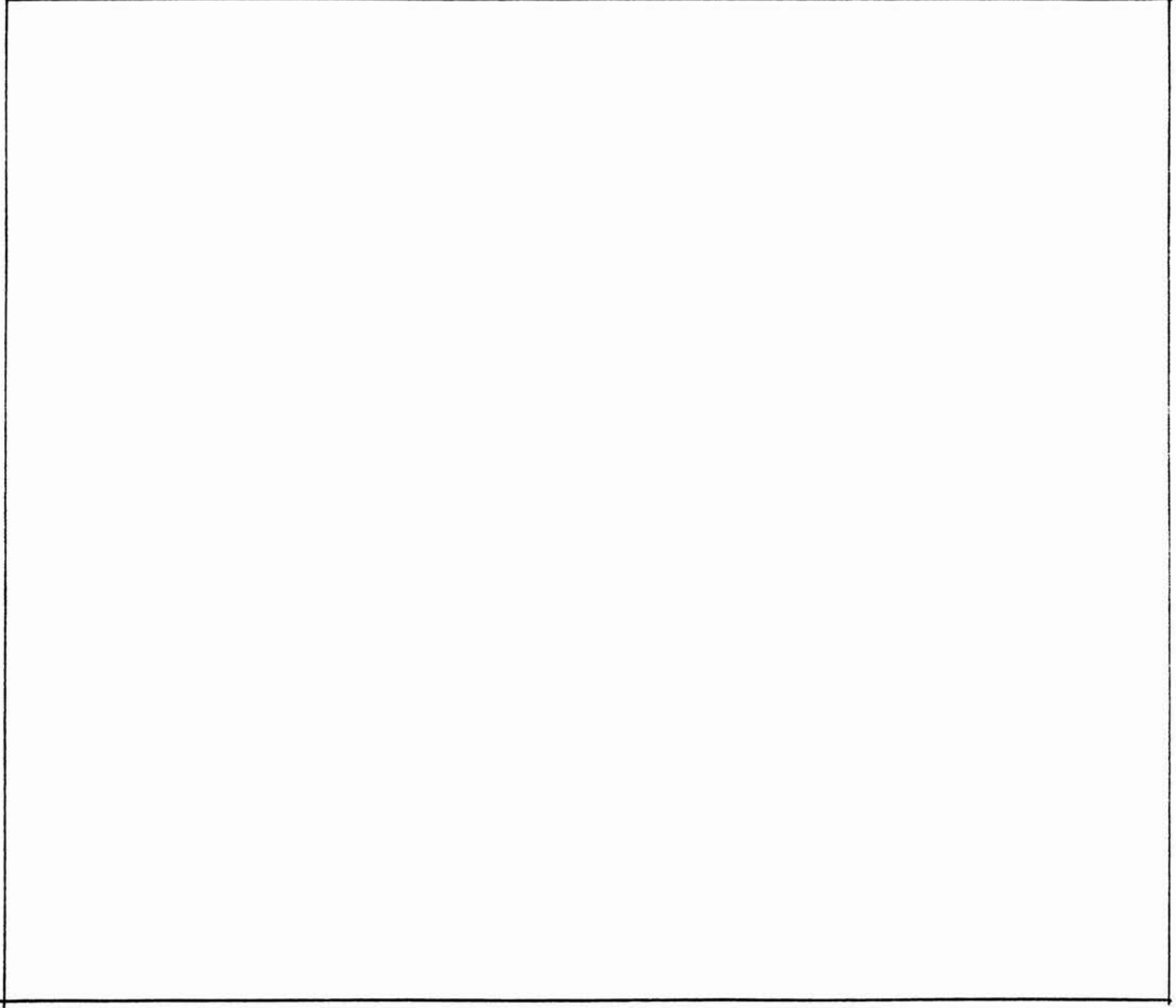
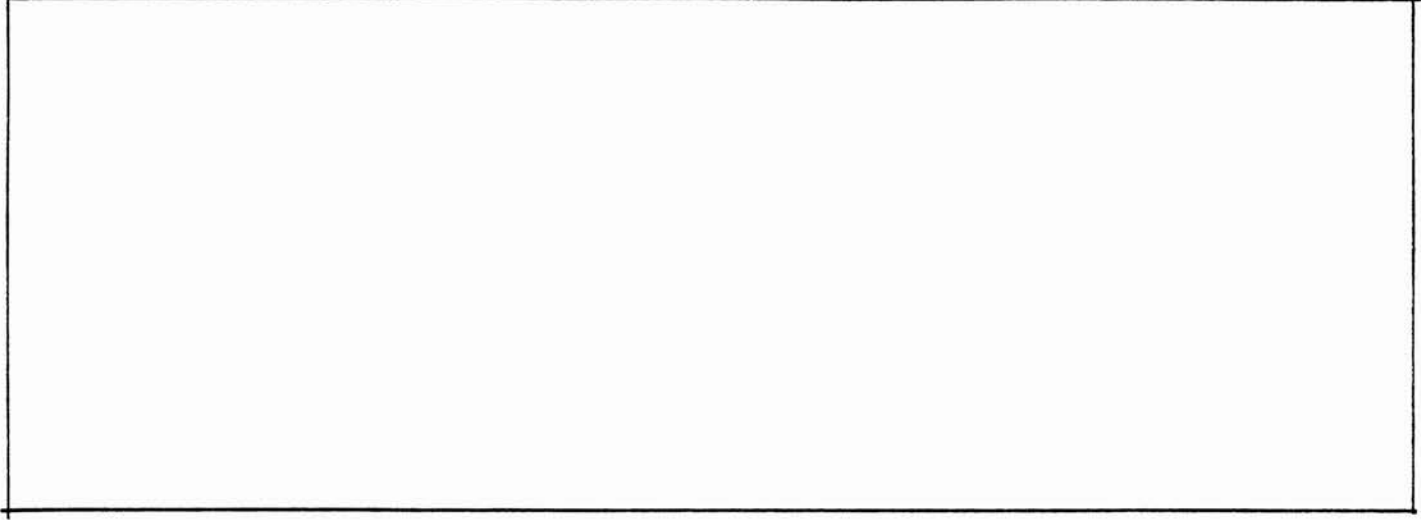

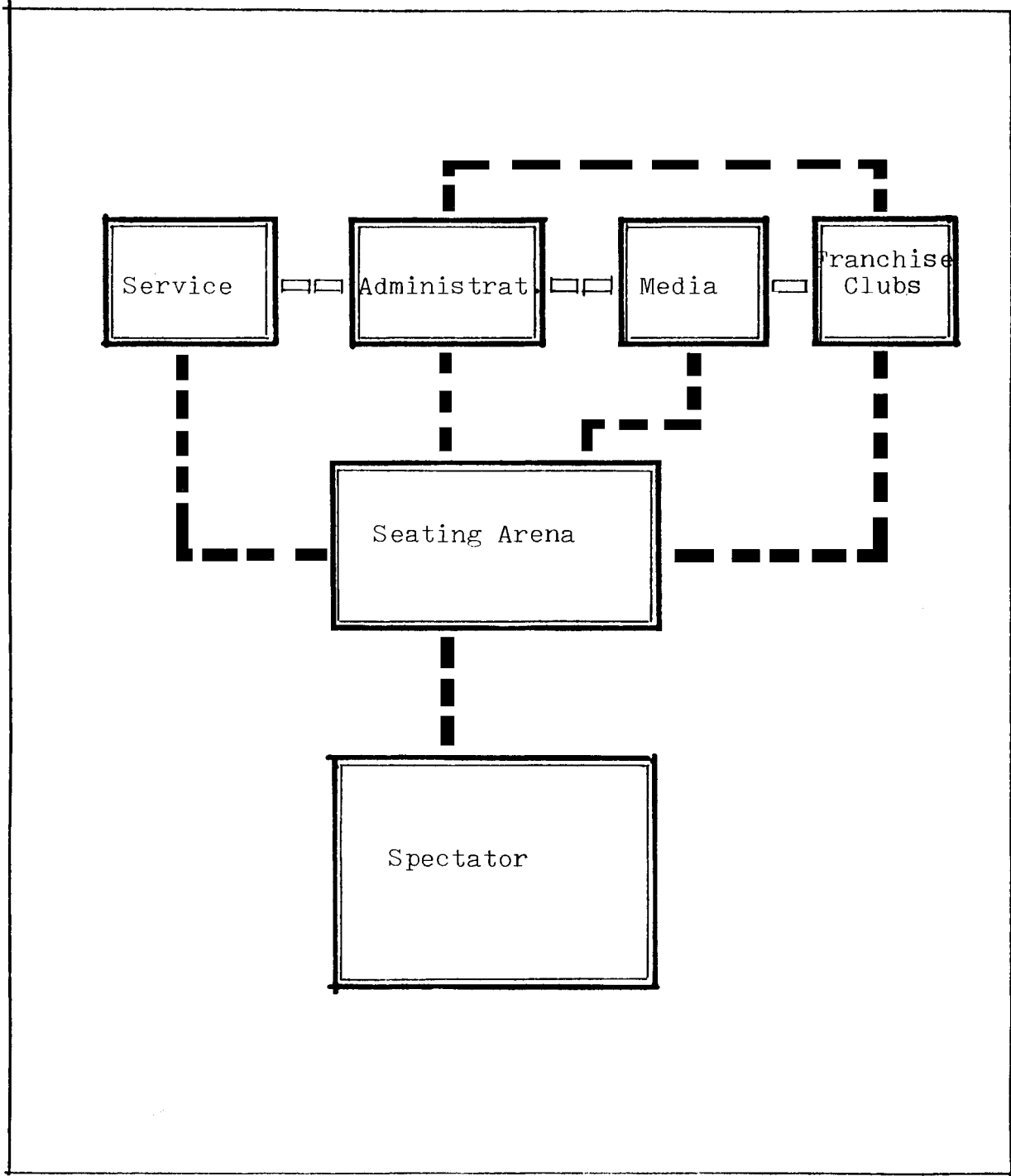

Building Relationships

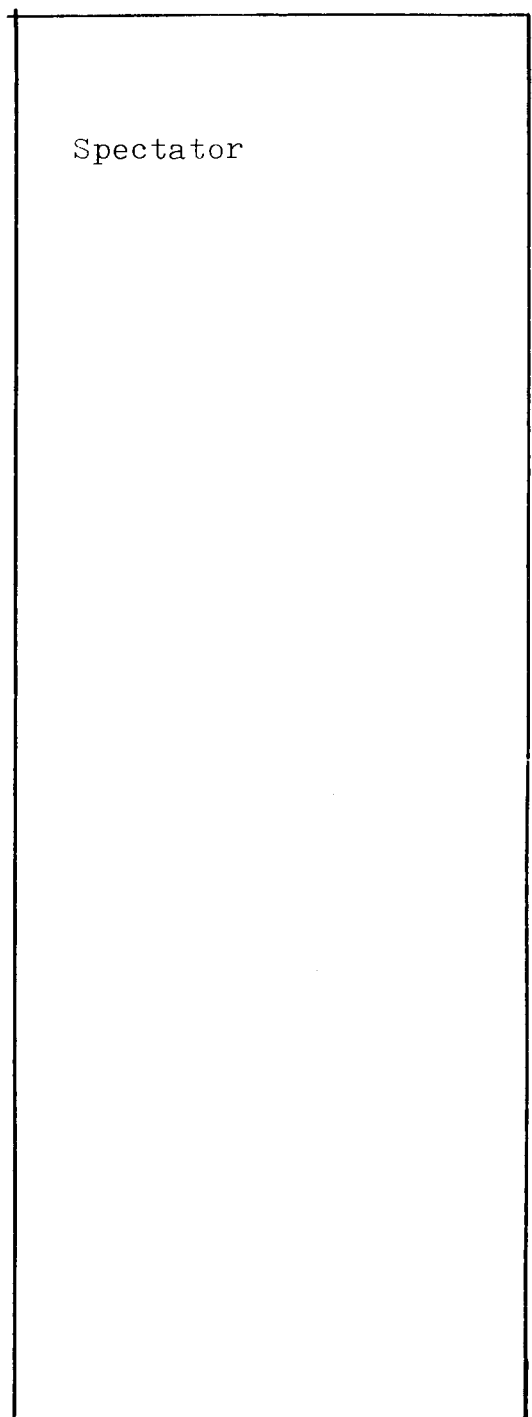
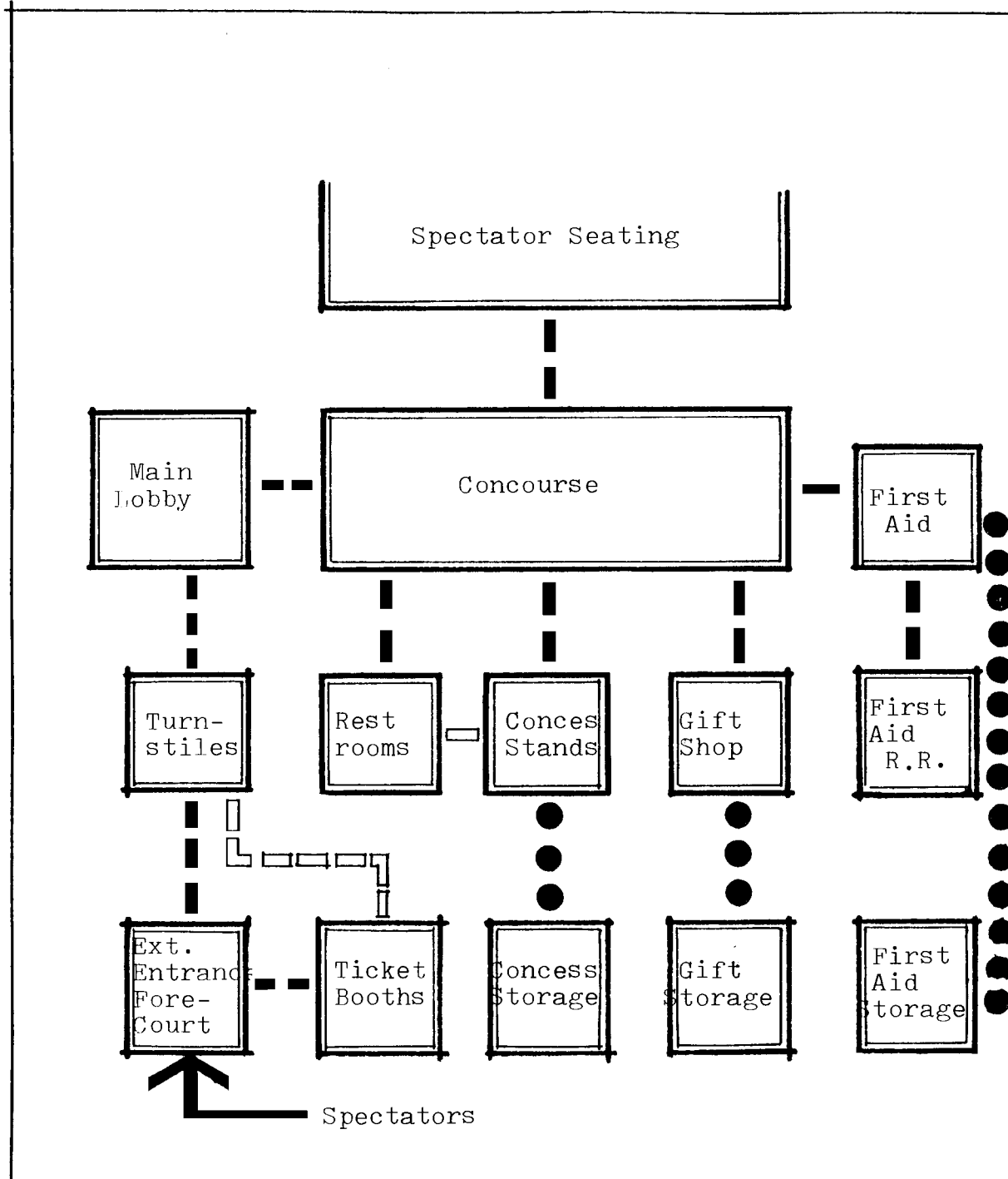

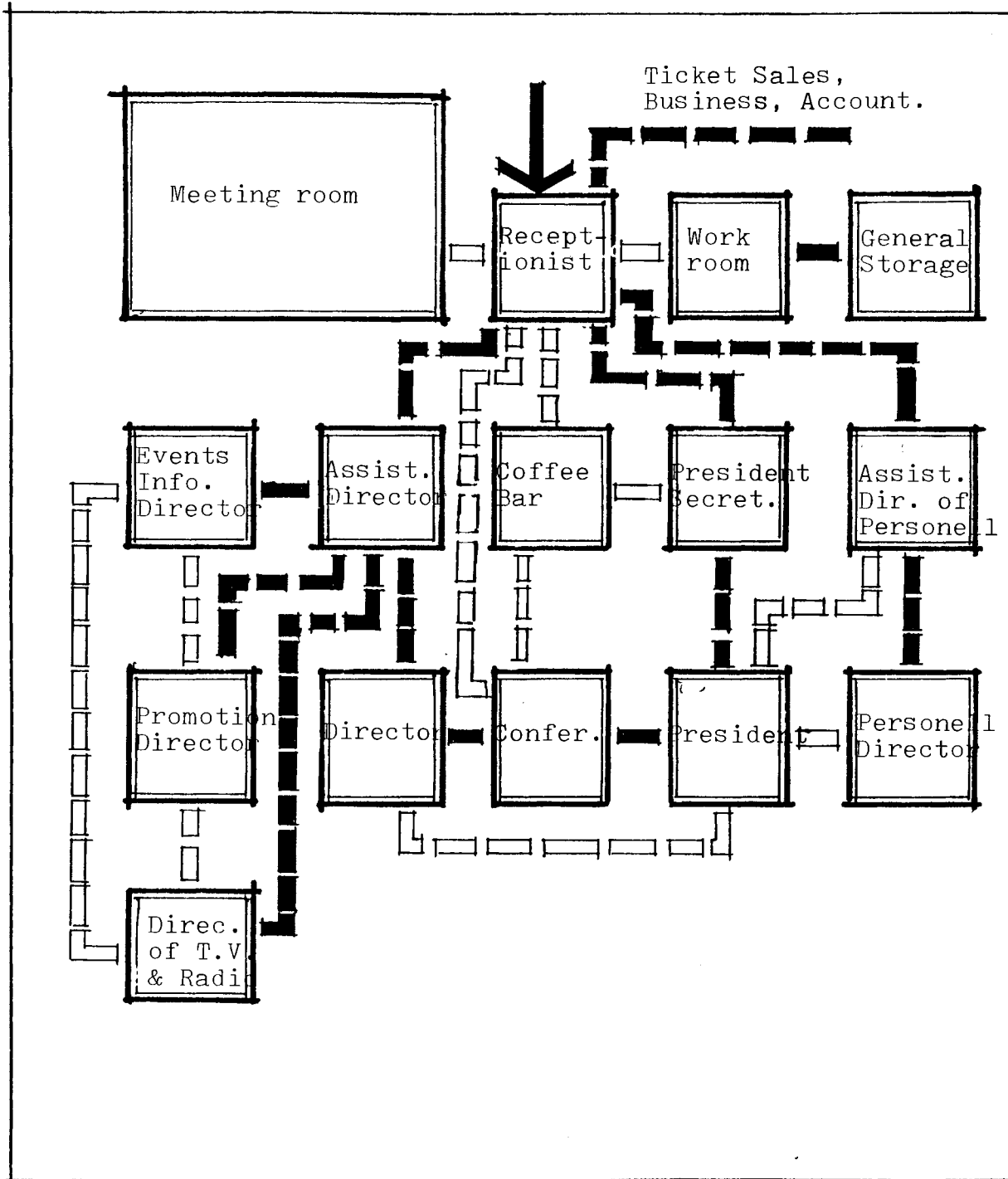

Administration
Directors

From Receptionist

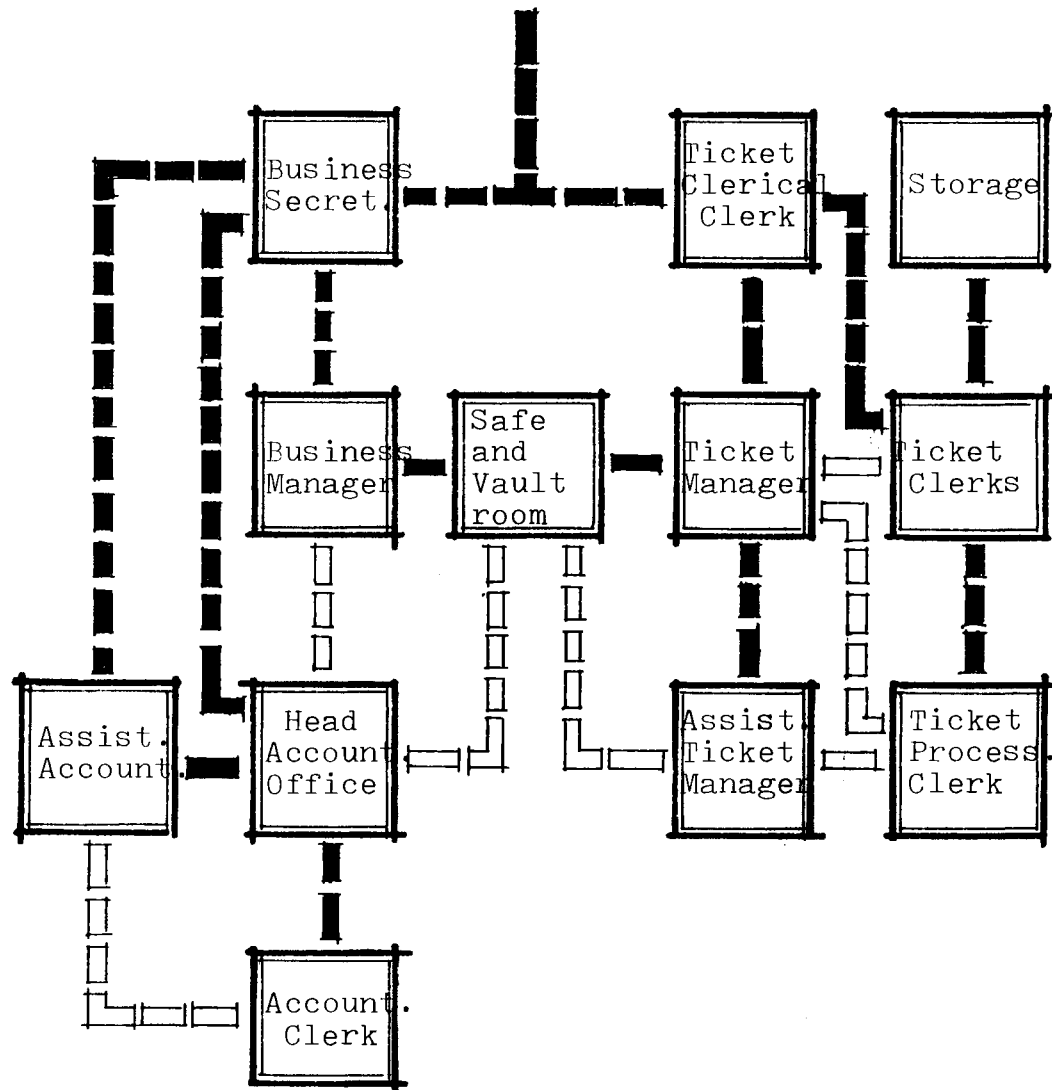

Administration
Ticket Sales
Business
Accounting

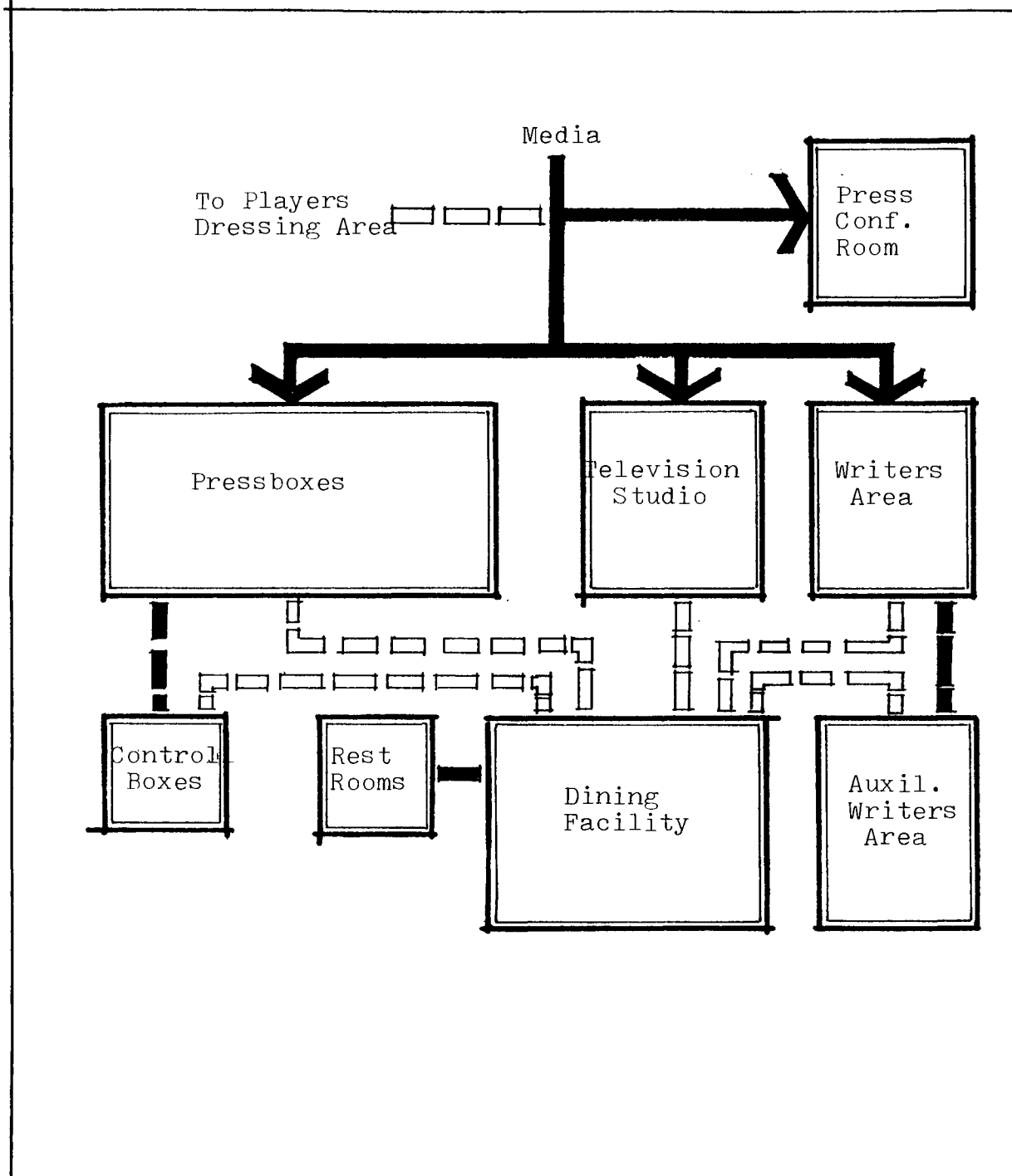

Media

Franchise Office,
Basketball Administration

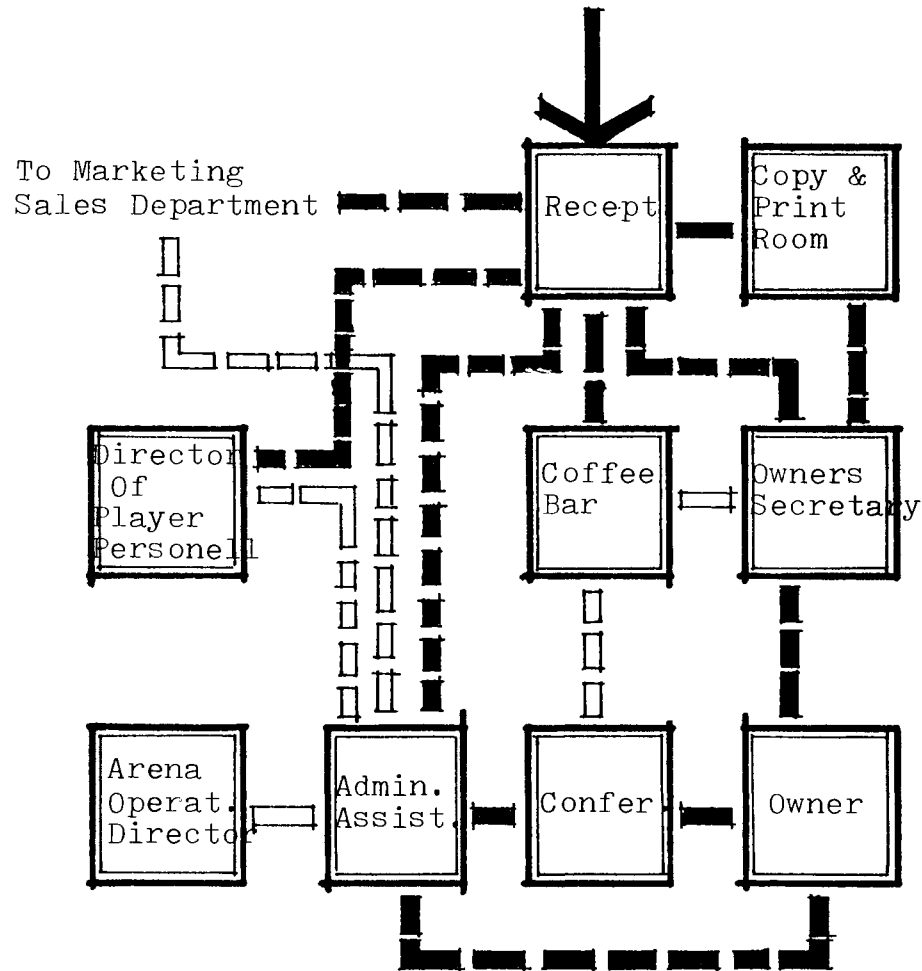

Franchise Office,
Basketball
Marketing and Sales

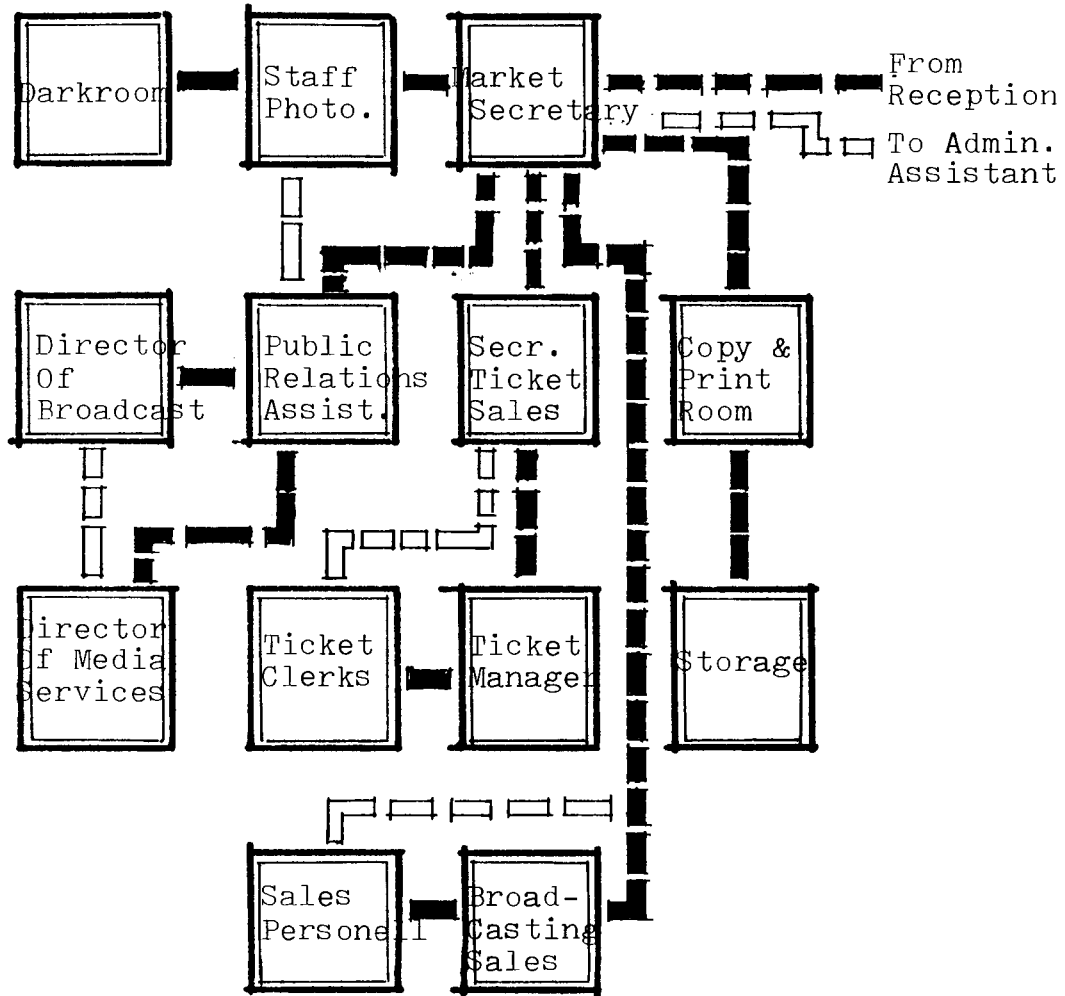

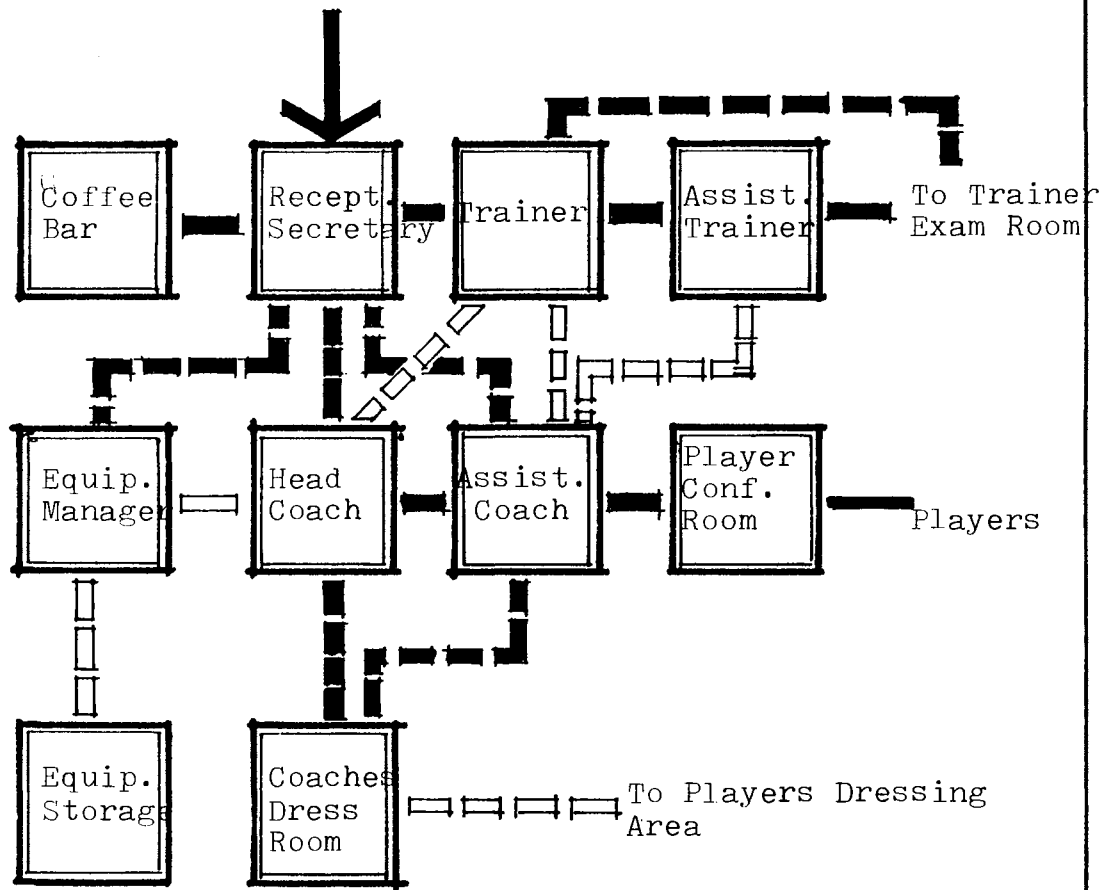

Franchise Office,
Basketball
Coaches Staff

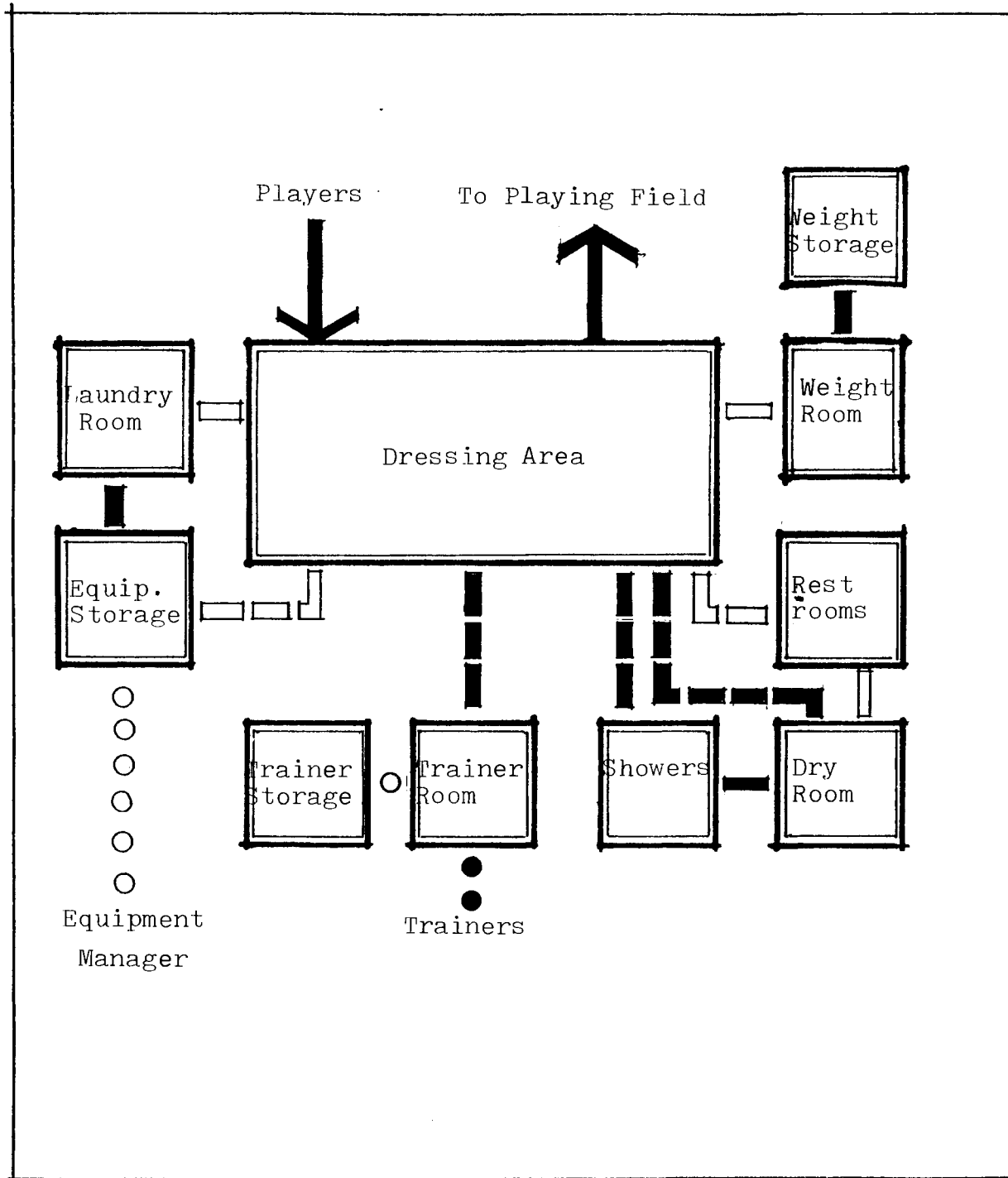

Franchise Office
Basketball
Players

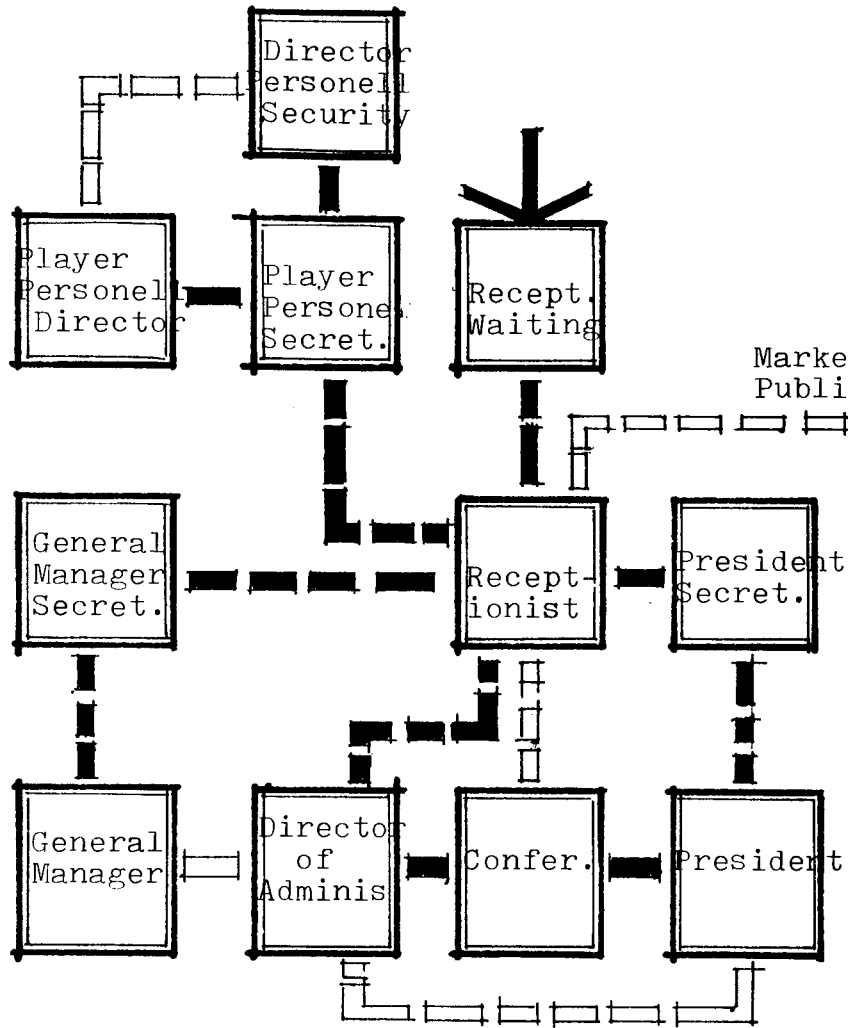

Franchise Office
Football
Administration

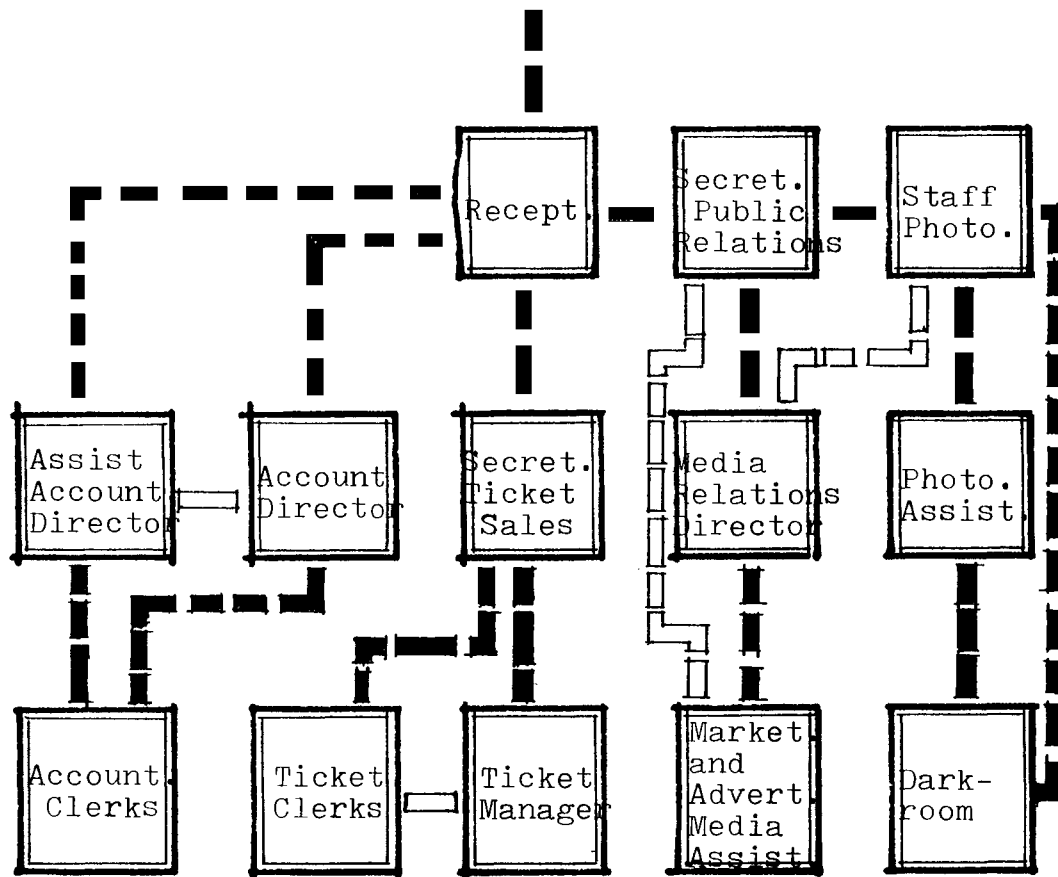

Franchise Office
Football
Marketing, Sales,
Public Relations

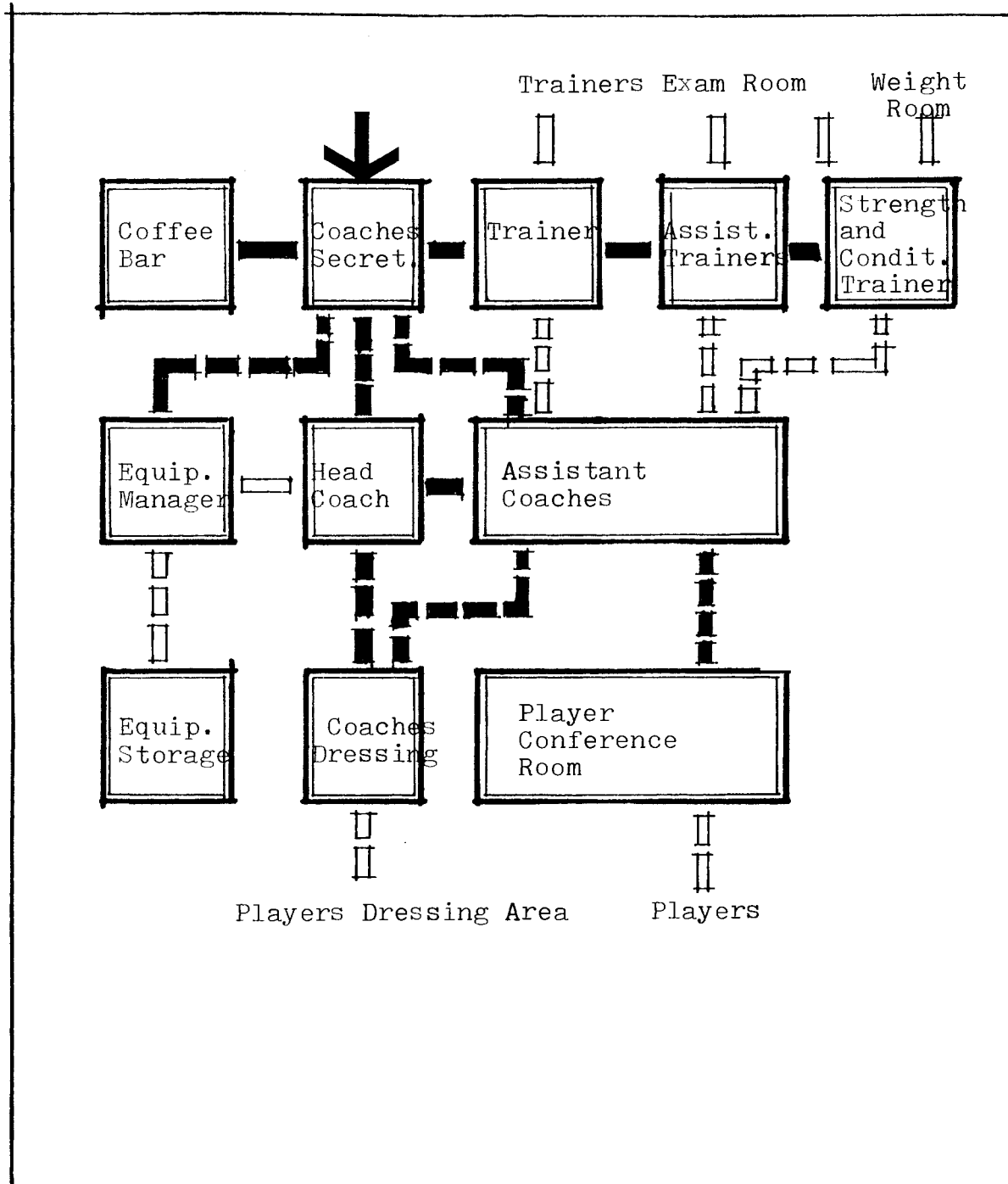

Franchise Office
 Football
 Coaches Staff

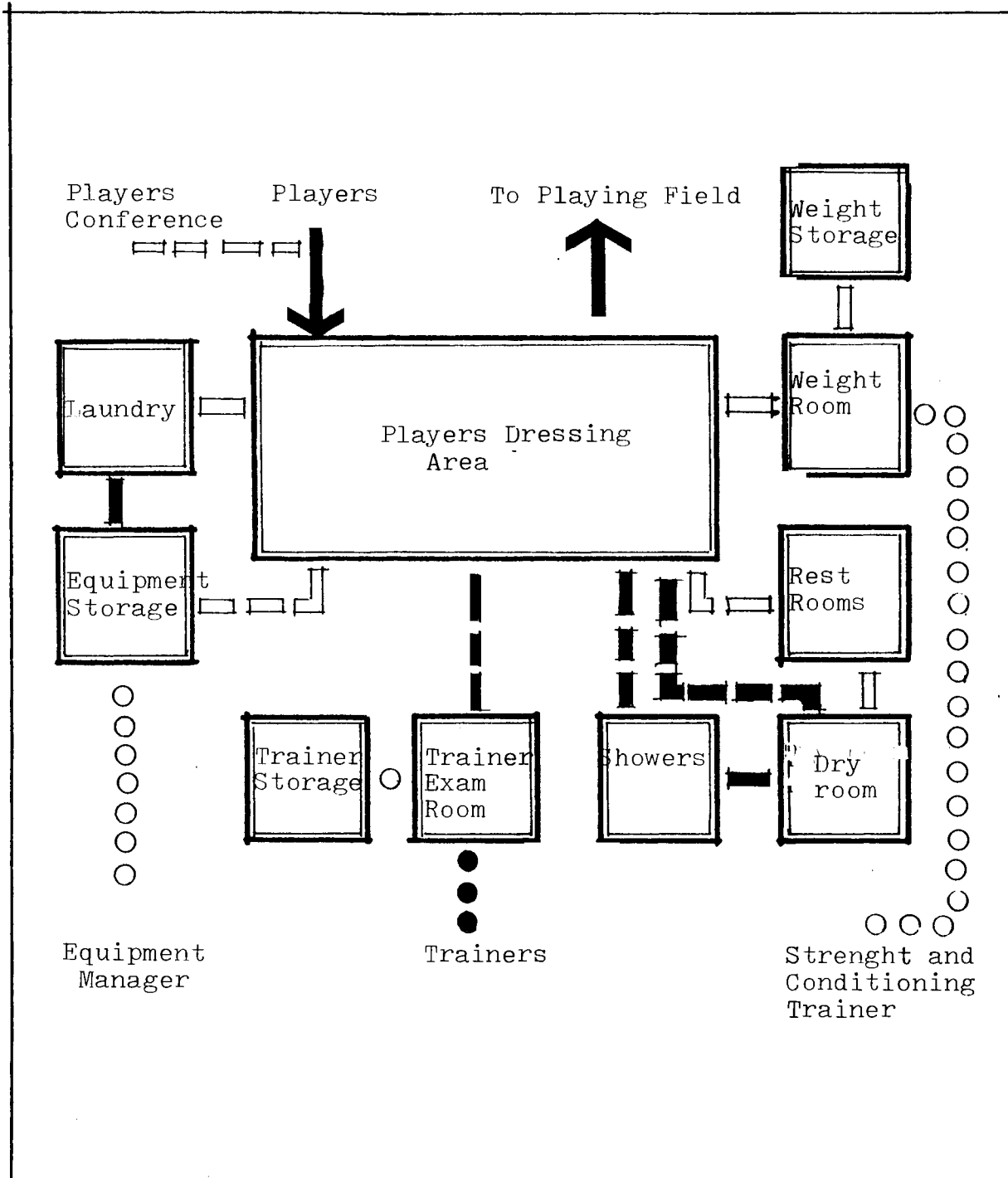

Franchise Office
 Football
 Player

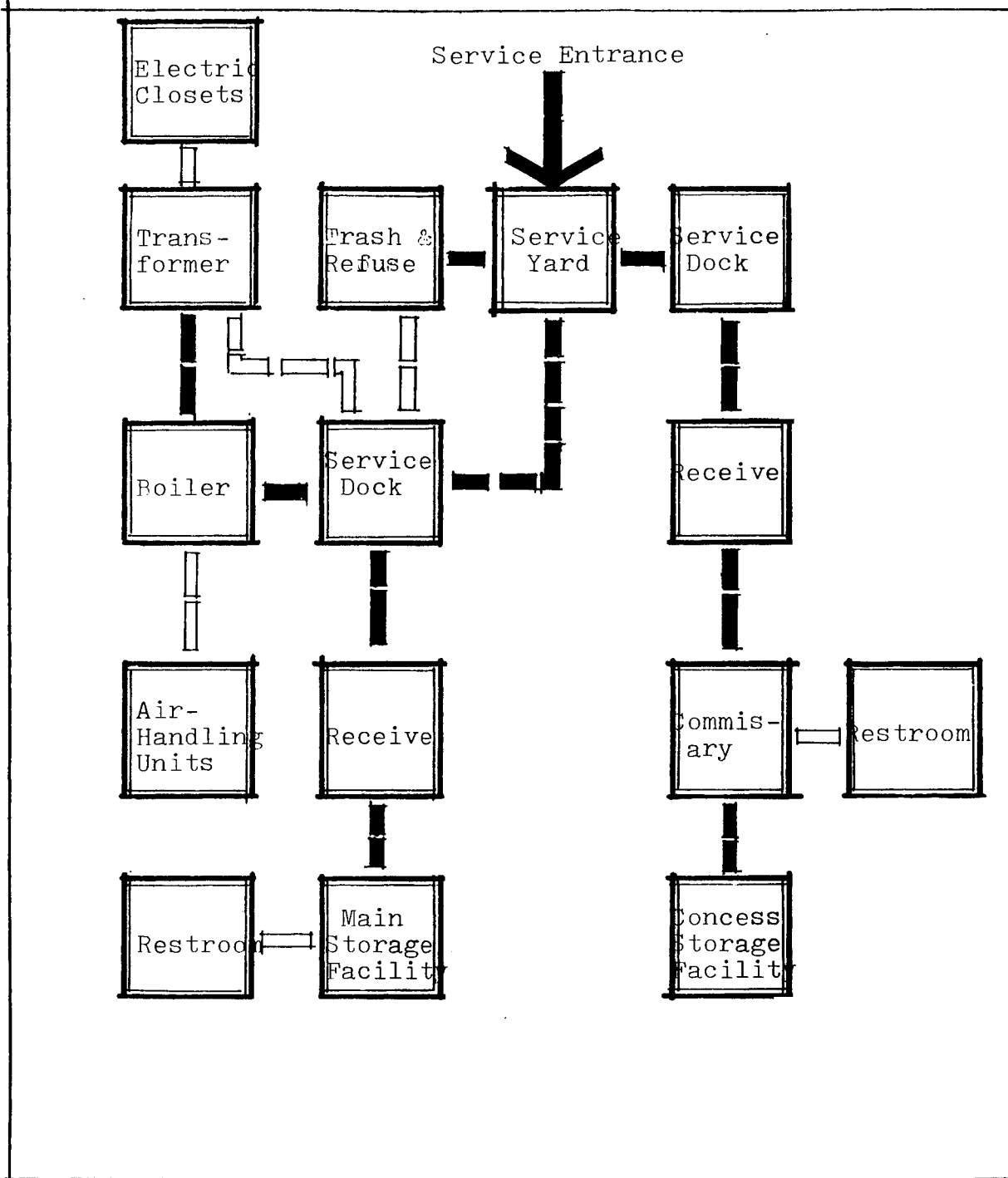

Service

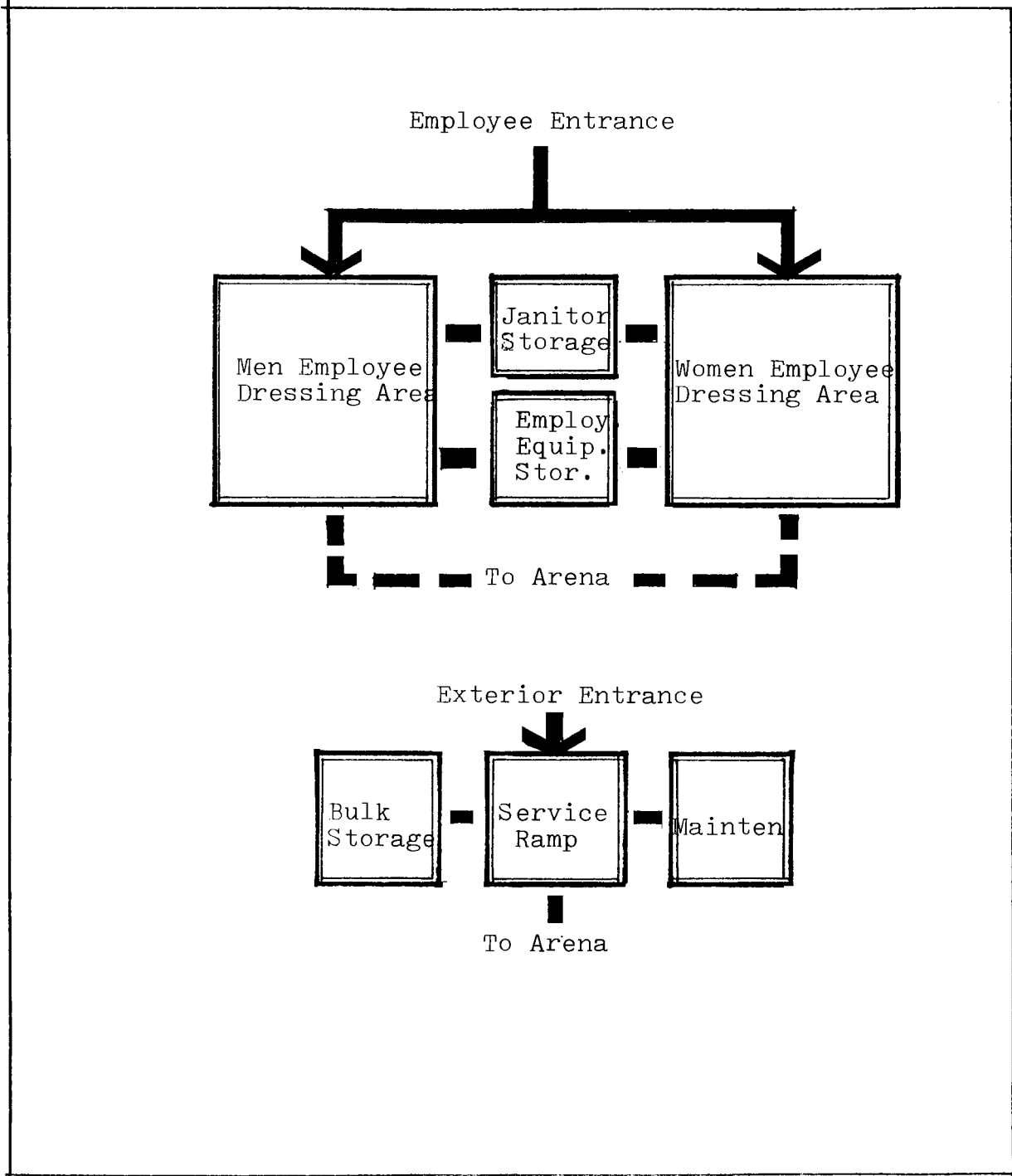

Service Employee

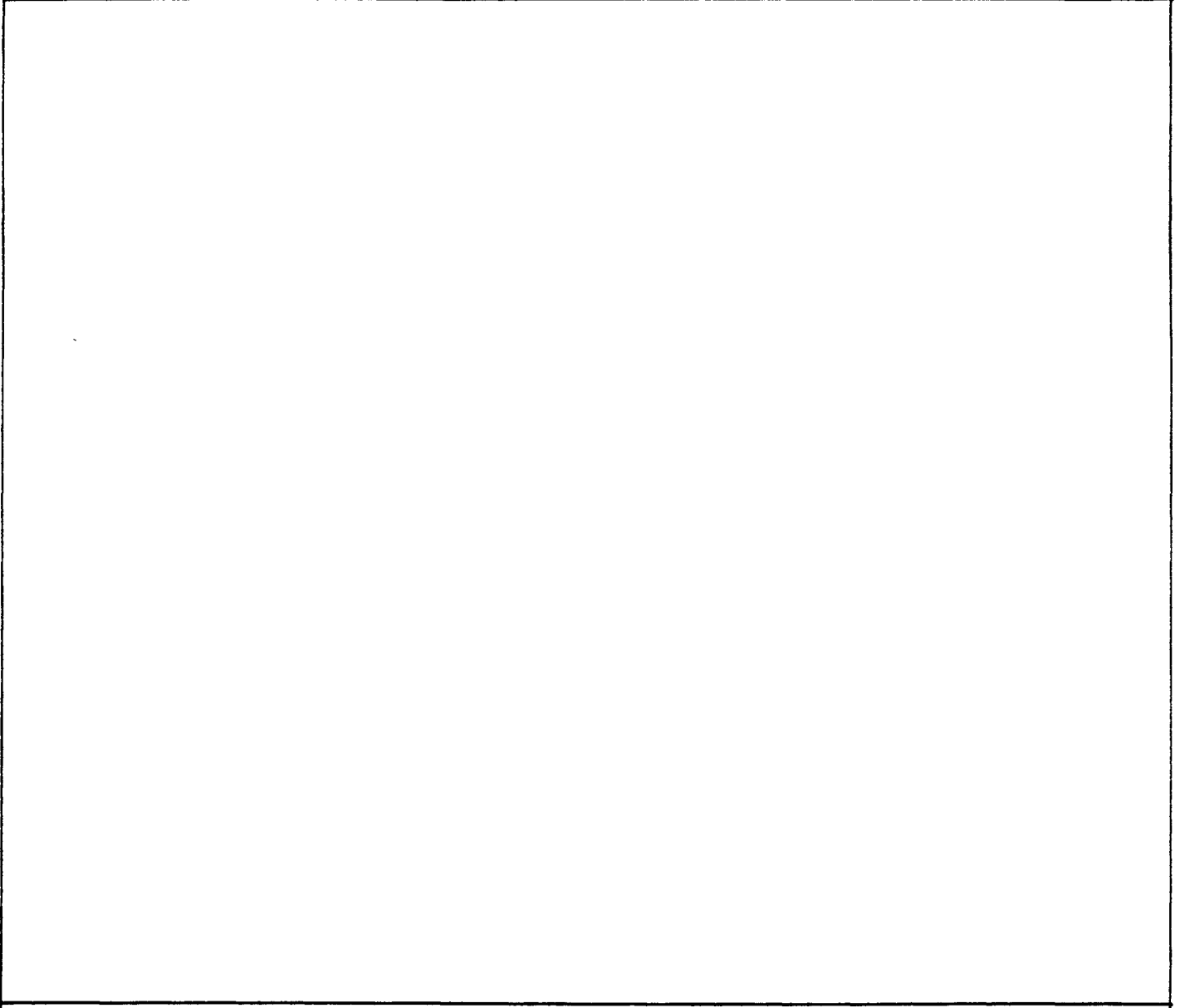
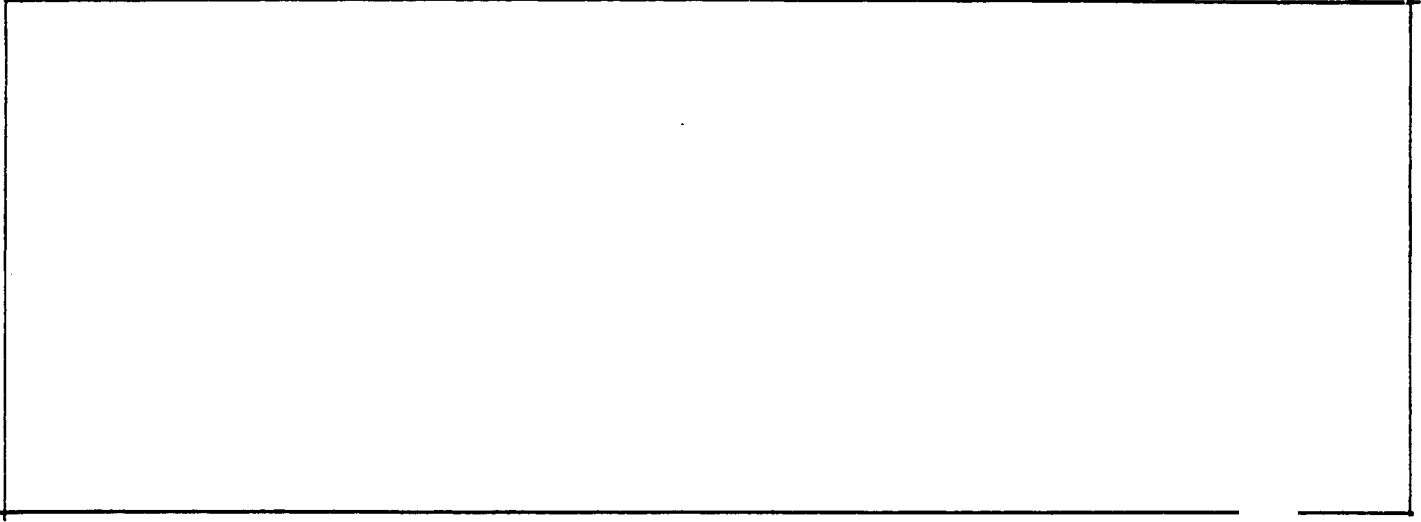

Montreal Olympic Center
Montreal, Canada

Taking firm possession of the Olympic parks narrow west sector is the 60,000 seat Olympic stadium. The structure plan is formed by 34 massive post-tension precast bents arranged radially in the pattern of a giant ellipse. Each bent is composed of a hefty, arch-backed column that supports a tapering beam with long front and rear cantilevers. The beam of the rear cantilever is turned back on itself and rejoined to the column, giving the stadium its characteristic "flying saucer" shape. The front cantilever, however, soars dramatically out over the seating tiers to a point 160 feet above the edge of the infield where it supports a 150-ton section of the technical ring, which contains lighting and other services, provides a discontinuous inner edging for concrete and sheet metal roof that shelters all the seating but leaves the center of the stadium open to the sky.

Had work not been postponed, the tower would have stacked 18 floors of assorted sports spaces one atop another, and culminated in a restaurant reached by a ride in an inclined elevator up the tower's tension leg. Just under the restaurant, the tower was designed to house a retractable canopy of fabric that could be lowered to cover the opening over the stadium so that the building could be used year round in any type of weather. This fabric roof was to be guided along its open-close path by a spray of cables that linked the top of the tower with a series of points around the roof just behind the technical ring. The 552 ft. mast cantilevers 175 feet over the stadium with the center of gravity falling 23 feet behind the front face of the mast which is anchored 160 ft. deep into rock at the rear. Architect was Roger Tailbert. Project cost 800\$ mil.

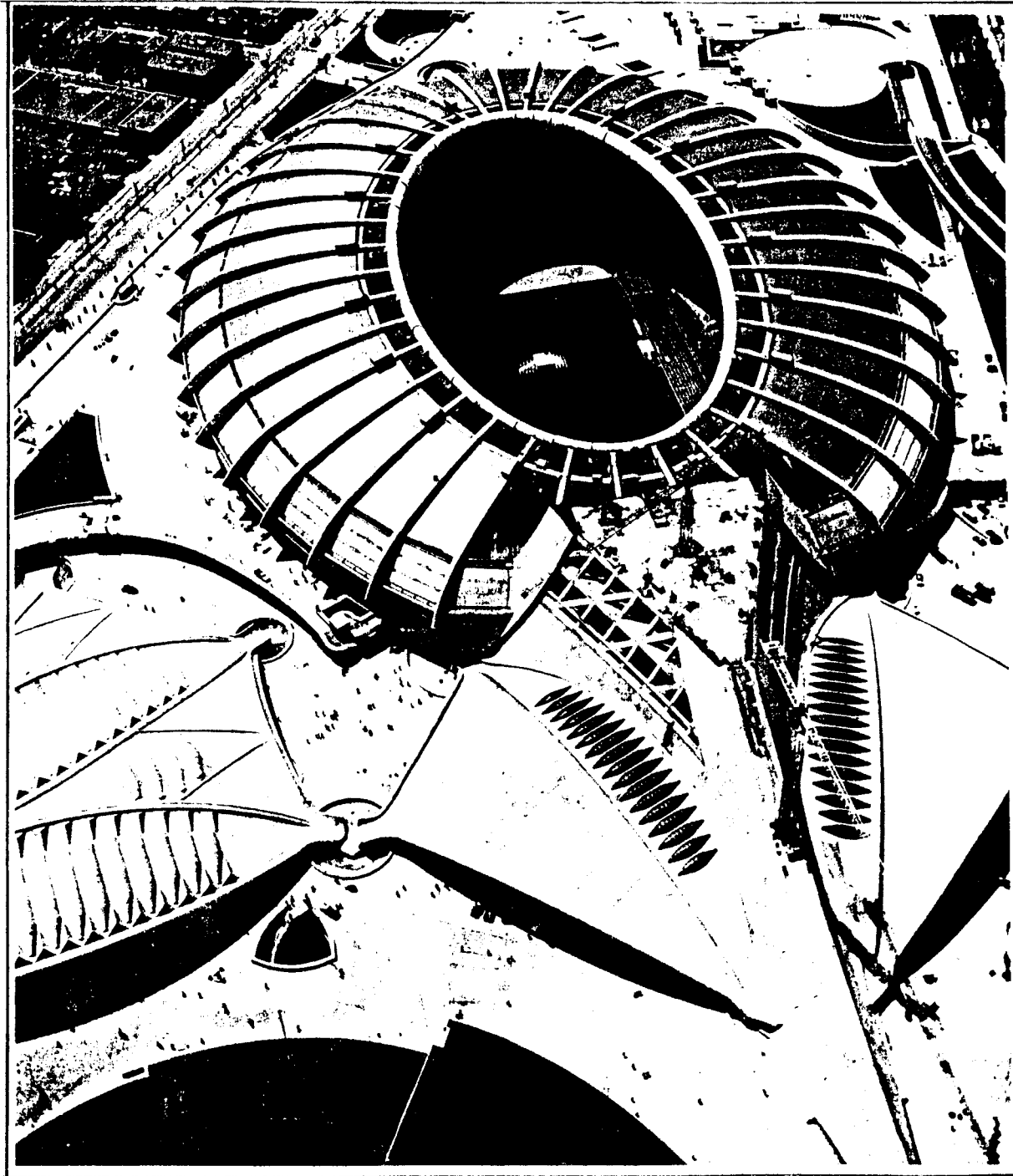

Montreal Olympic Center

MULTI-USE SPORTS FACILITY, OKLAHOMA CITY

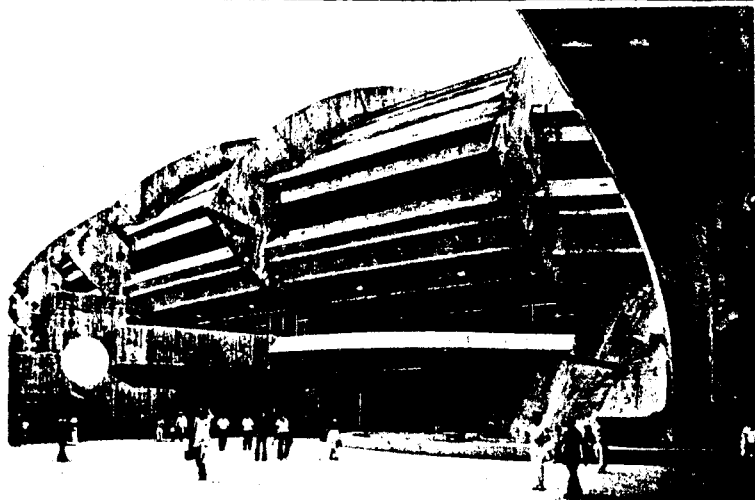

Olympic Park

1. Olympic Stadium 2. Swimming Pools 3. Velodrome 4. Charbonneau Center 5. Maurice Richard Arena

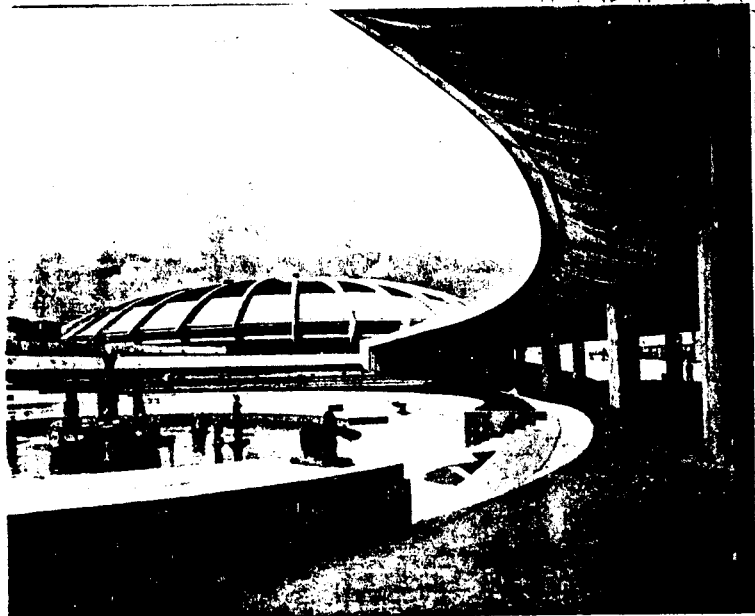
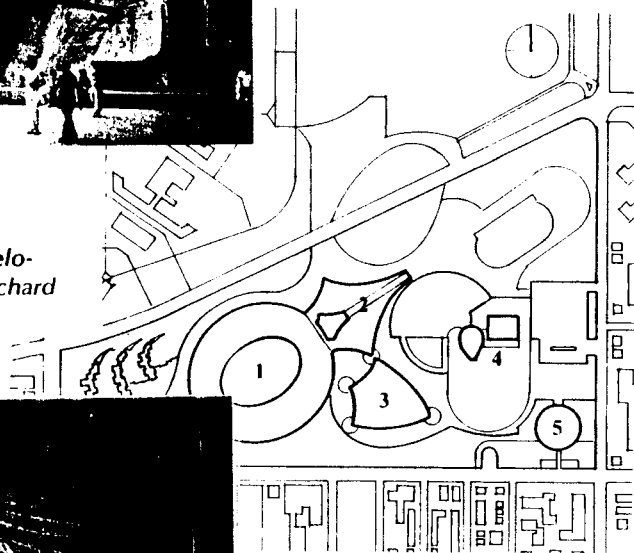

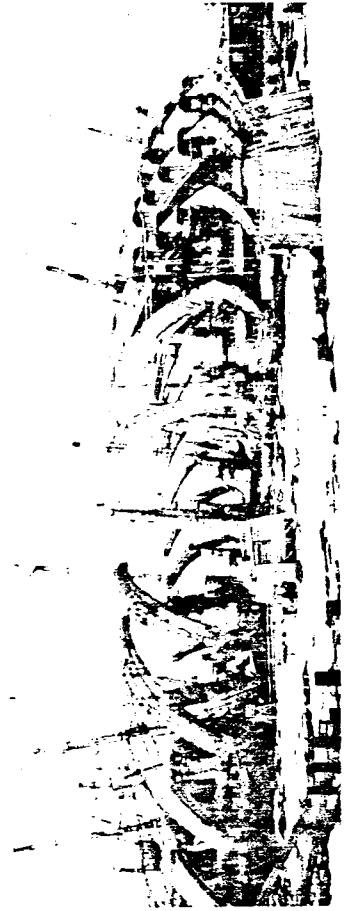
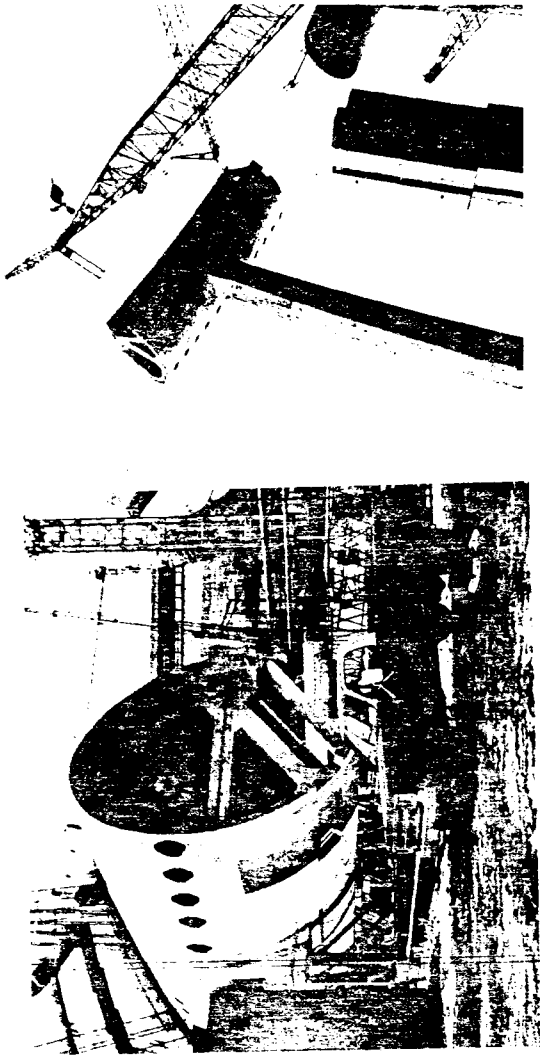

Carver-Hawkeye Sports Arena
Iowa City, Iowa

The primary design concern for the sports arena was to reduce the scale of this large container of 15,200 seats and four levels of support facilities under a three-and-a-half-acre roof. Siting the building in a natural ravine pushed its bulk below grade. The salient structural features, a light-weight steel space truss, spans the ravine with the support of eight concrete columns and cantilevers out beyond them to shelter a pedestrian promenade. Hanging the roof from the bottom chord of the truss places the fascia at a perceptible height above the head of the visitor, creating an entry scaled to the spectator, not the spectacle.

Inside, the space explodes or, more accurately, implodes like a crater. Proceeding along the promenade, which is like walking around the edge of a precipice, one has commanding views down onto the arena floor, up into the roof structure with its translucent, two-bay oculus, and around and through the buildings glazed periphery. Hanging the roof from the bottom chord also reduced the volume to be heated and cooled, resulting in a significant saving of energy, and as the structure expands and contracts due to thermal loads, a system of guided column supports absorbs the movement without imparting lateral loads to the columns.

Four of the seven building entries have airlocks which is another energy conscious feature. These entries are framed by glass block pods that extend from beneath the fascia and screen concession stands and restrooms. Thus, the wall of the building is translucent and visually light, perceptually negating the arena's bulk. By day this wall floods the promenade with light, while at night the glass block acts as a marquee.

The service wing to the north abuts the arena in panhandle fashion. Its four levels contain locker rooms, equipment storage, offices, conference rooms, etc. While the bottom level accessible from the arena floor is somewhat gloomy, the upper levels are brightened by skylights and floor cutouts.

While the arena's high-tech esthetic is not immediately identifiable with anything Iowan, a closer look reveals qualities that make it right for its region. This is a very muscular building that is fitting for a sports facility. The university athletic program is its strength and rallying point, and the arena communicates the vigor through steel trusses, exposed mechanical systems, and undulating walls.

- 1 Arena
- 2 Terrace
- 3 Concessions
- 4 Ticket sales
- 5 Ticket office
- 6 Television camera platform
- 7 Handicapped viewing area
- 8 Skylights
- 9 Toilets

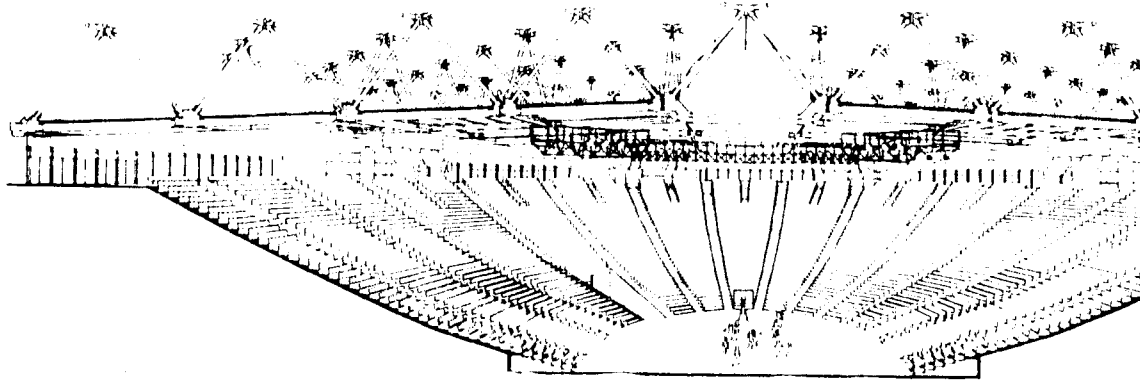
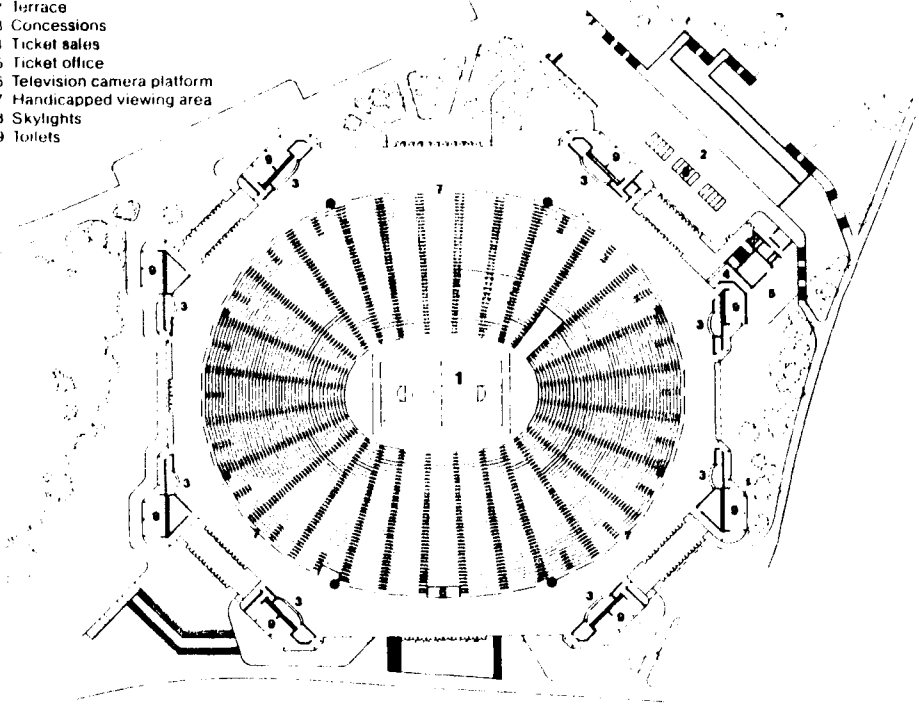

MULTI USE SPORTS FACILITY, OKLAHOMA CITY

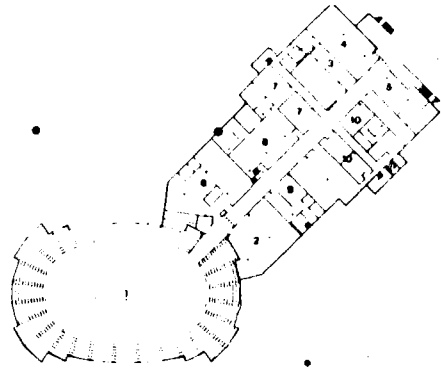

- 1 Arena floor
- 2 Storage
- 3 Laundry
- 4 Mechanical
- 5 Shipping
- 6 Framing
- 7 Classroom
- 8 Women's lockers
- 9 Basketball lockers
- 10 Visitor's lockers

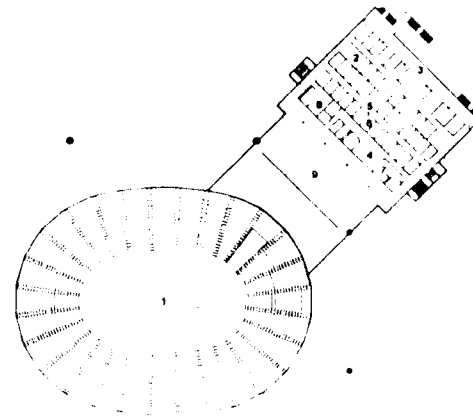

- 1 Arena
- 2 Sports information
- 3 Terrace
- 4 Wrestling lockers
- 5 Light court
- 6 Coaches offices
- 7 Men's coaches lockers
- 8 Women's coaches lock
- 9 Wrestling practice

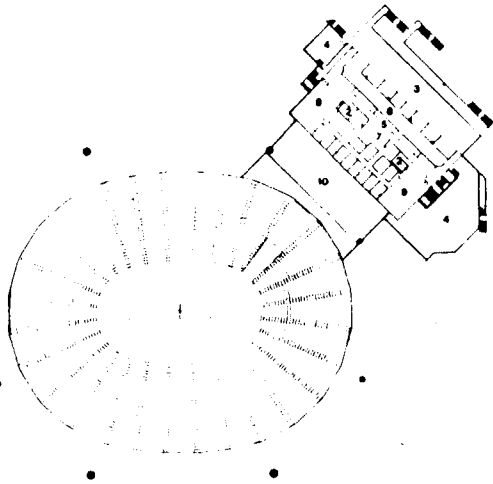

- 1 Arena
- 2 Toilets
- 3 Terrace
- 4 Mechanical
- 5 Light court
- 6 Athletic offices
- 7 Football coaches
- 8 Iowa room
- 9 Big ten team
- 10 Open for wrestling practice below

Crosby Kemper Arena
Kansas City, Mo.

Intended for a variety of sports, shows, and conventions, this arena seats up to 16,00-18,000 people. The oval shape of the interior, with overlapping upper and lower seating tiers, brings the spectator as close as possible to the arena floor. Four rooms for mechanicals at the upper level give the building a rectangular shape and create overhangs providing cover for the spectator entrances.

In an effort to provide as much interior space as possible without encumbering it with bulk and distracting structural supports or having to wrap it in bulky envelope, the architects have used three primary rigid steel structural bents on the outside. These are 27 ft. deep with panel points 54 ft. on center and are braced on the diagonal with three-inch rods that span 324 ft. total. The piling caps at the base are smoothly tapered above grade to provide an elegant base to receive the loads. The roof is framed by a nine-foot secondary trusses, suspended from the primary structural bents.

On the inside, technical and structural components have been left exposed and painted bright colors to create an environment which reflects the recreational character of the building. A measure of acoustical control is achieved with a fiberboard ceiling suspended from the metal deck.

Like any other sports arena Kemper arena is designed for flexibility.

The architects for the facility were C.F. Murphy and Associates.

The building costs were at 10.2 Million, but with changes by the owner final costs were \$13.5 mil.

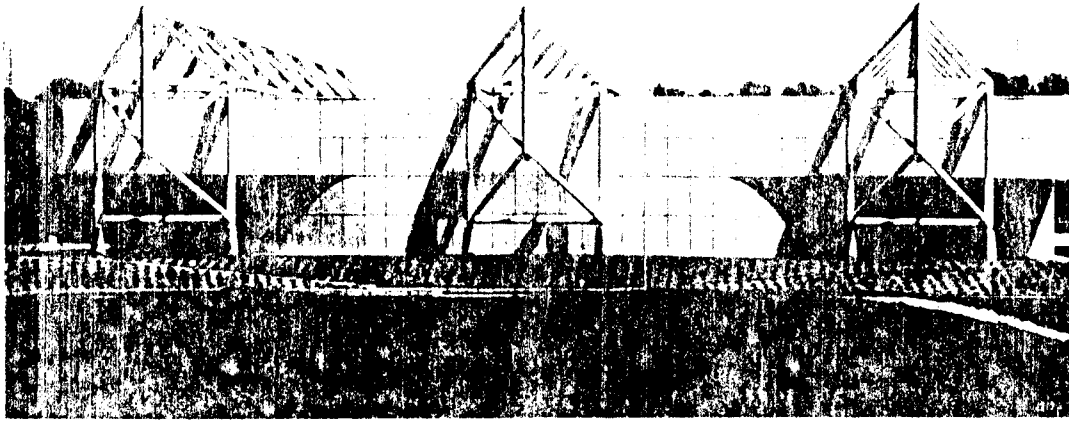

Electrical

Mechanical

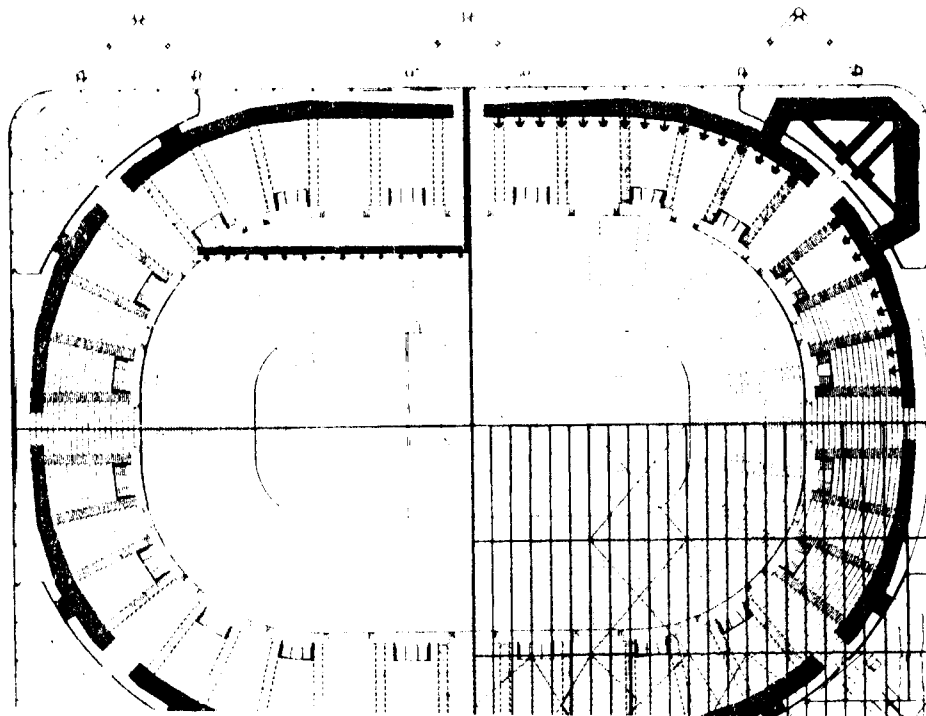

Architectural

Structural

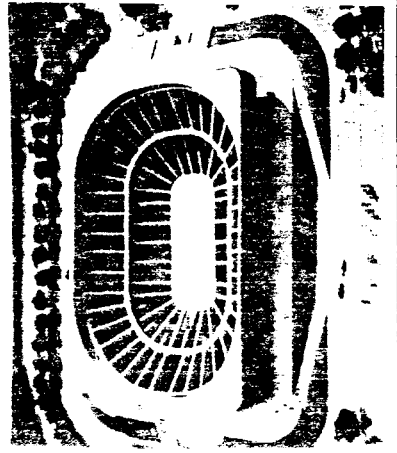
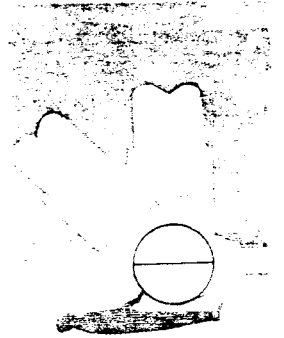
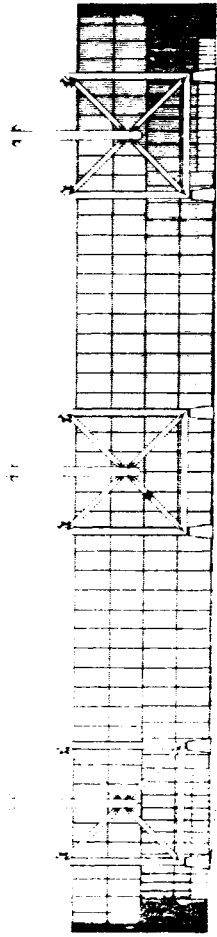
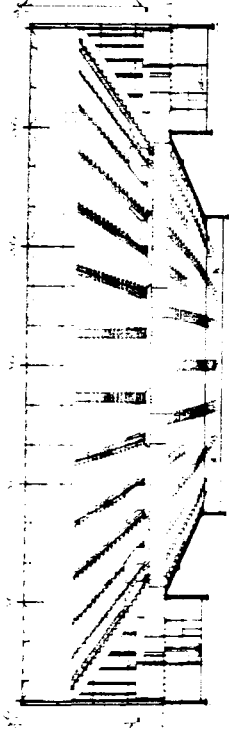
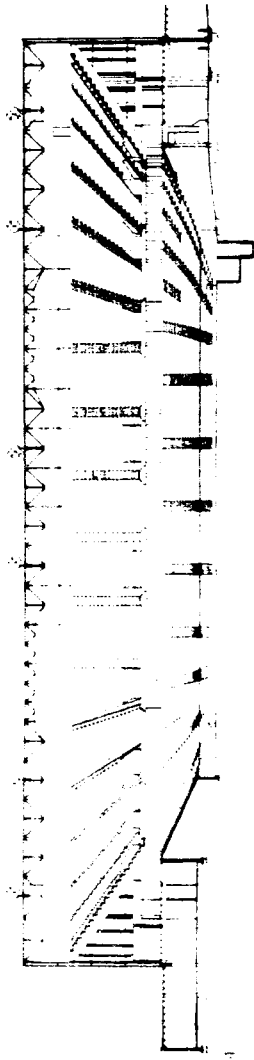

New Orleans Superdome
Louisiana

The major design goal behind the Superdome was flexibility. It was designed with a system of moveable grandstands on the first or plaza level. Using any one of the four basic field configurations, the Superdome can seat anywhere from 19,142 for basketball and arena shows to 95,427 for convention size activities. The multi-purpose facility seats 78,000 for Football. The facility also provides 300,000 s.f. of exhibit space and parking for 5,100 cars.

The moveable stands are located on both east and west sides of the field, and consist of solid steel deck grandstands 25 rows high. The total weight of these stands is almost 1,000 tons, and have a seating capacity of approximately 15,000, each side being 550 ft. long.

When the stands are extended onto the field for events such as football, they are connected to the concourse by means of 12 removable pedestrian bridges, six on each side of the field. This allows spectators to move from the stands to the concourse with its concessions and restroom without having to descend to field level.

When the stands are moved back for large-field activities, such as baseball or conventions, the bridges are raised out of the way and suspended in storage under the structure of the seating level above. The movable stands are then retracted and become the lower level of seating for baseball.

The pipe-column understructure rides on steel roller units which travel in steel trenches 10 in. deep and 15 in. wide.

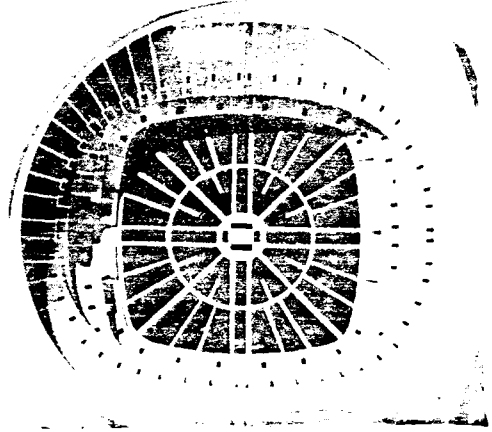
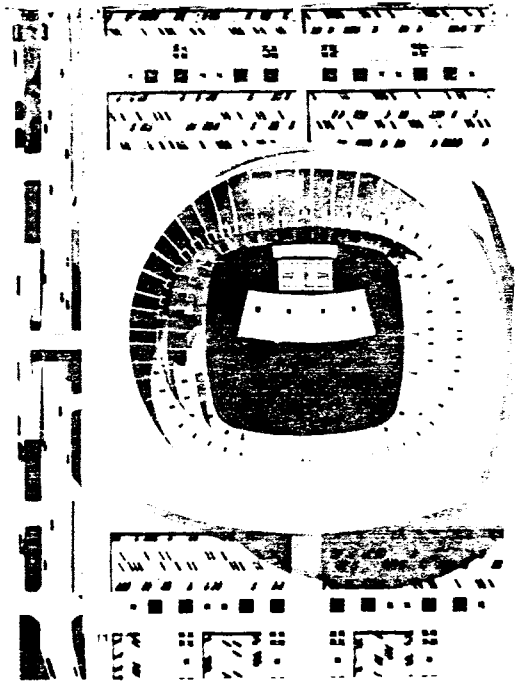
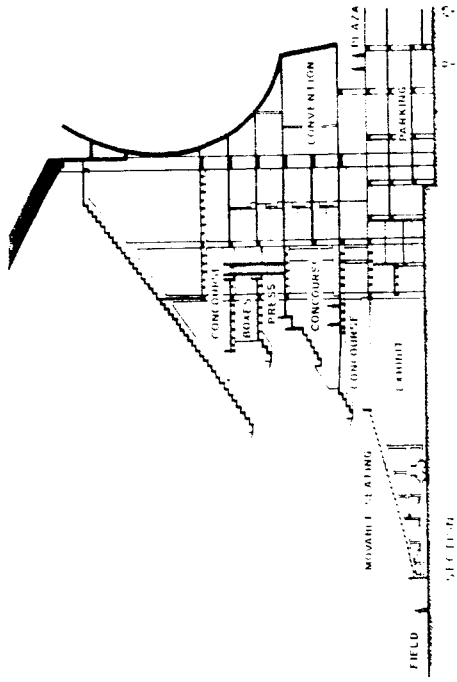

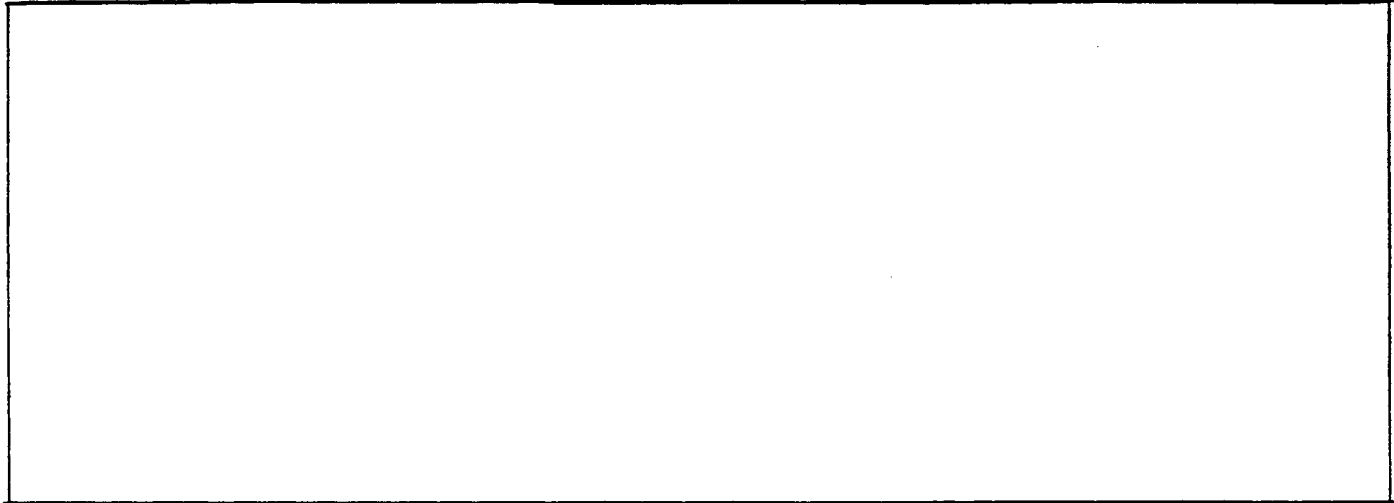
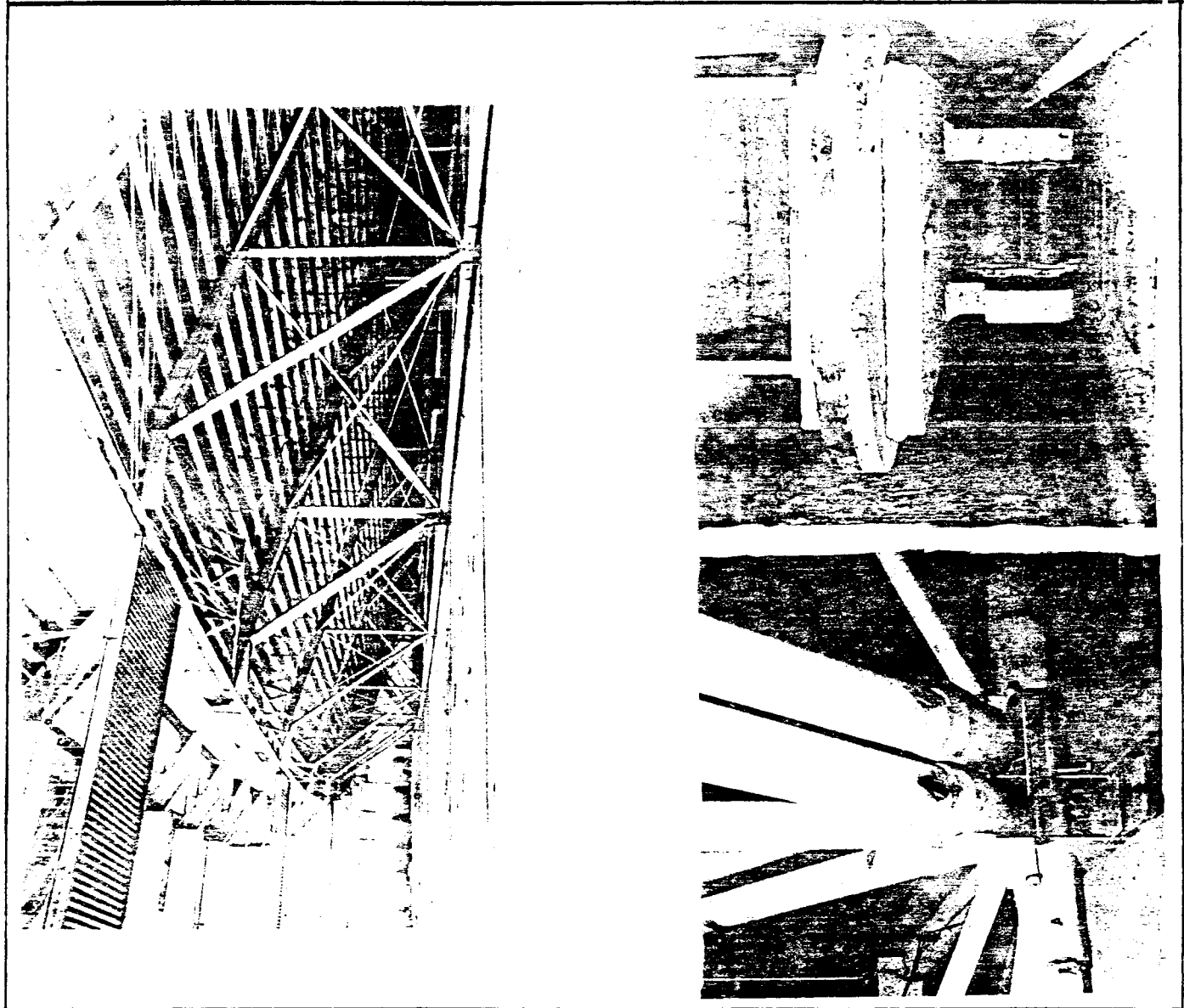

MULTI USE SPORTS FACILITY, OKLAHOMA CITY

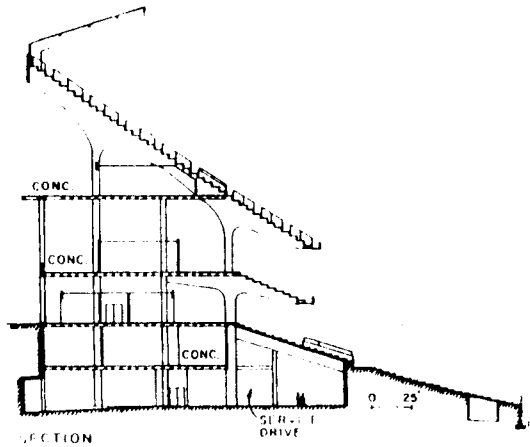

Two sports for two Stadiums designed by Kivett and Meyers for Jackson County Sports Complex, Kansas City. The football stadium seats 70,000 while the baseball stadium seats 48,000. The twin stadium approach avoid compromise of dual purpose stadiums. Cost is around \$54 Million, with a removeable roof planned to come later at a cost of \$11 million.

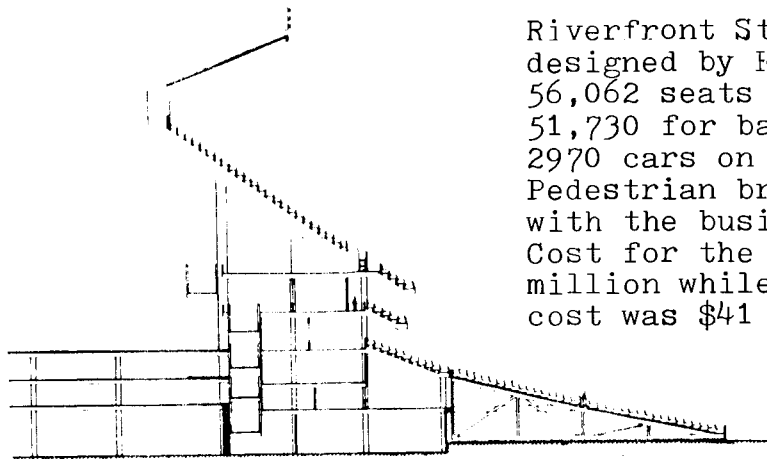

Riverfront Stadium in Cincinnati designed by Finch-Heery. Has 56,062 seats for football and 51,730 for baseball. Parking for 2970 cars on three levels. Pedestrian bridges link stadium with the business district. Cost for the stadium was \$26.4 million while the whole project cost was \$41 million.

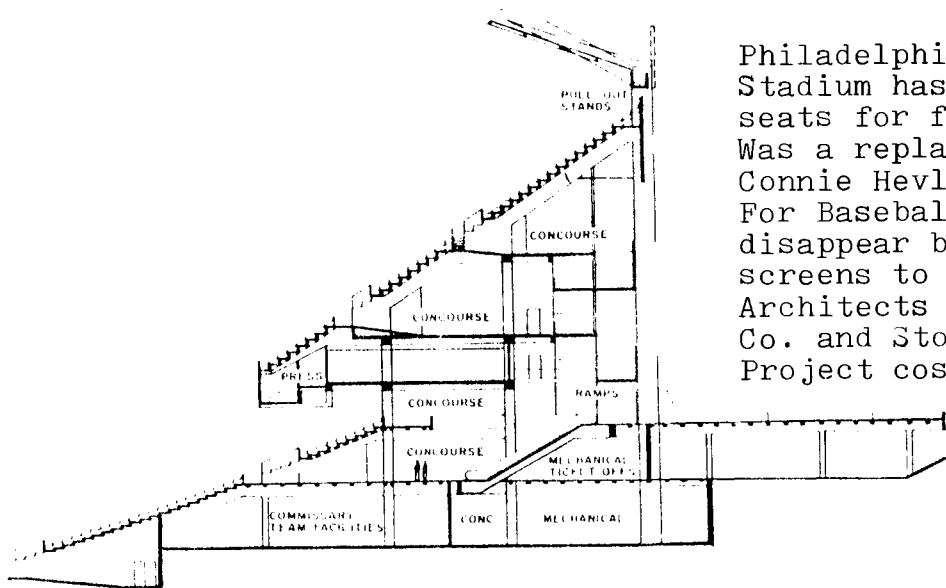

Philadelphia's Veteran Stadium has 65,000 seats for football. Was a replacement for Connie Hevlack Stadium For Baseball seats disappear behind roller screens to seat 50,000 Architects were Ewing Co. and Stonorov/Haws. Project cost \$31 mil.

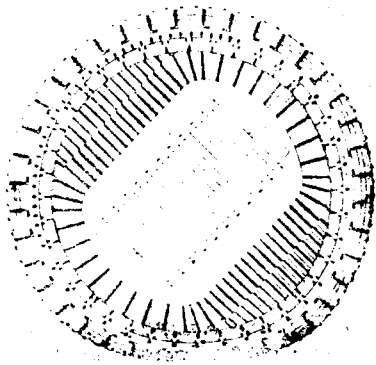
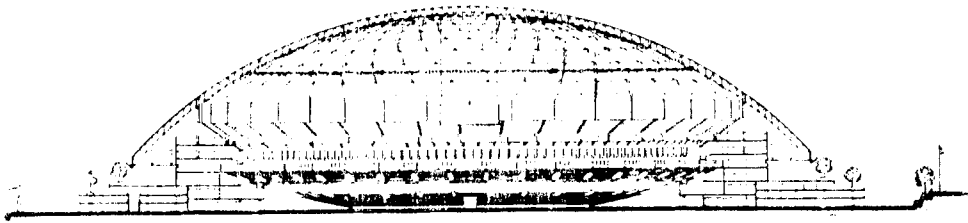

Domed stadium design for Wayne County Stadium in Detroit. Seats 60,000 for football, 25000 for basketball and hockey. Has a 872 ft. diameter dome with an open plaza overlooking the Detroit River. Below the plaza there is parking for 25,000 cars. Pedestrians also have their own system of ramp. Architects are Giffels/Finch/Heery/Stone with the project cost of \$85 million.

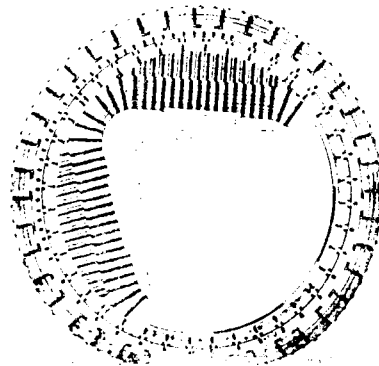

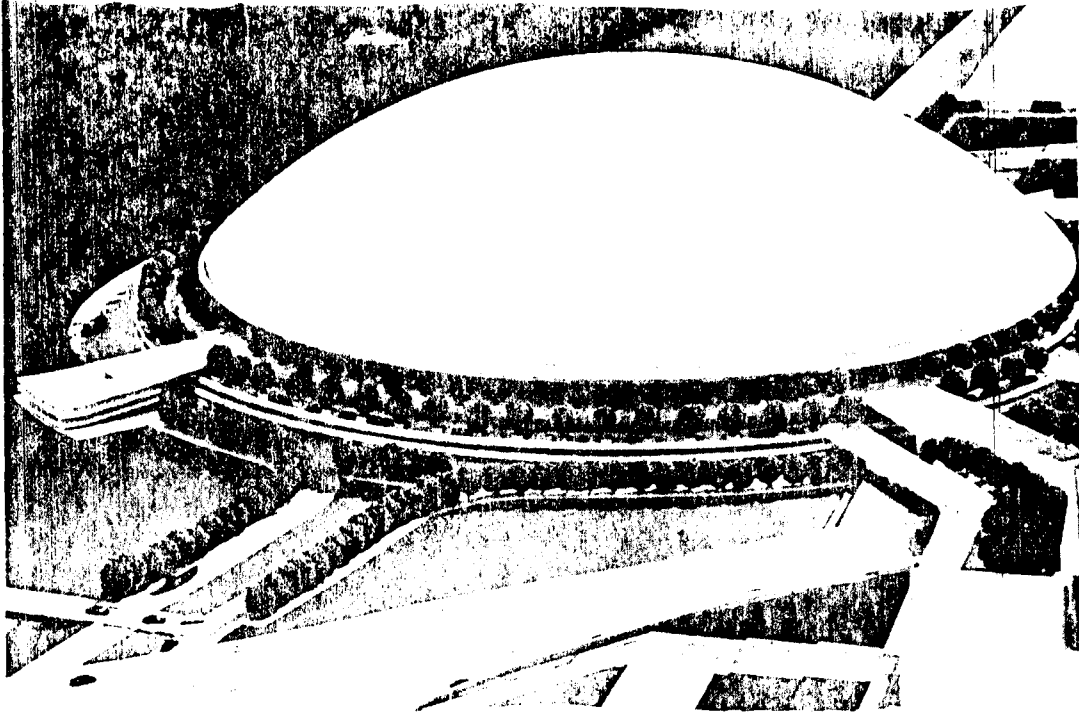

Details and perspective of Wayne County Stadium, Detroit

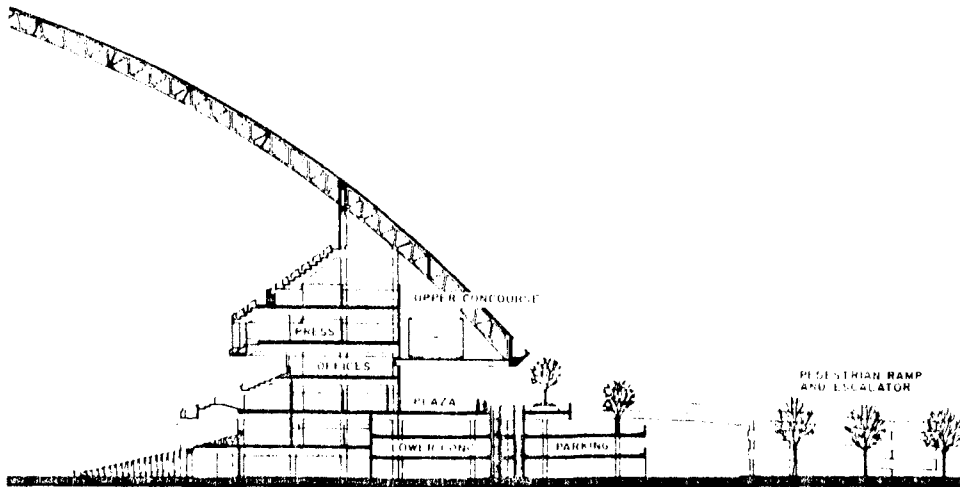

OKLAHOMA STATE UNIVERSITY LIBRARY



3 6135 00010 6676

A MULTI-USE SPORTS FACILITY FOR OKLAHOMA CITY, VOL. 2

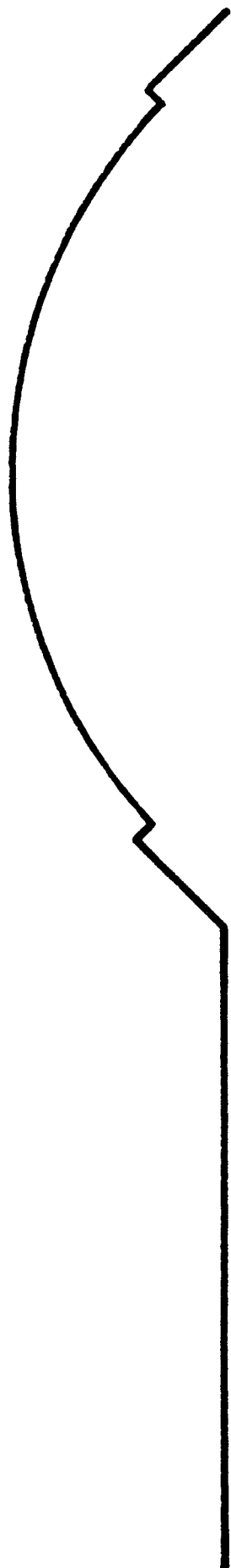

T 1000

1085R

1085R

V. 2

VOLUME TWO

AREA REQUIREMENTS

A MULTI - USE SPORTS FACILITY
FOR OKLAHOMA CITY

VOLUME TWO

AREA REQUIREMENTS

This Volume is part of a two volume series and contains the Area Requirements for the Oklahoma City Multi-Use Sports Facility. Volume One is bound under a separate cover and contains Site Analysis and Research.

JOHN J. HANSEN

MULTI USE SPORTS FACILITY, OKLAHOMA CITY

AREA REQUIREMENTS

A large, empty rectangular box with a thin black border, occupying the upper half of the page. It is intended for detailing area requirements.A large, empty rectangular box with a thin black border, occupying the lower half of the page. It is intended for providing project details.

MULTI-USE SPORTS FACILITY, OKLAHOMA CITY

<u>Area</u>	<u>S.F.</u>	<u>Page No.</u>
Car Parking	9,800,000	1
Monorail Dropoff Points	-	2
Exterior Entrance Forecourt	-	3
Main Lobby	5000	4
Turnstile	3500	5
Concourse	50000	6
Restrooms	13000	7
Concession Stands	24000	8
Concession Storage	6000	9
Gift Shop	1000	10
Gift Shop Storage	150	11
First Aid Rooms	450	12
First Aid Storage Room	60	12
First Aid Rest Room	150	12
Spectator Seating	210,000	13
Box Suites	36,000	14
Restaurant	8,000	15
Lounge	4,000	16
Kitchen	2,000	17
Net square footage	363,310	
+ 15% circulation	417,806	

Spectator

<u>Area</u>	<u>S.F.</u>	<u>Page No.</u>
Lobby and Reception	750	19
Presidents Office	600	20
Presidents Secretary	250	21
Directors Office	300	22
Assistant Directors Office	200	23
Events Information Director	200	24
Promotions Director	175	25
Director of T.V. and Radio Comm.	175	26
Maintenance Director	175	27
Ticket Coordinator	200	28
Assistant Ticket Manager	150	29
Ticket Processing Clerk	150	30
Ticket Clerical Clerk	150	31
Ticket Clerks	500	32
Business Manager	250	33
Business Manager Secretary	150	34
Head Accountant Office	200	35
Assistant Accounting Director	150	36
Accounting Clerks	700	37
Personell Manager	250	38
Assistant Director of Personell	250	39
Coordinator of Facilities and Purch.	250	40
Administrative assistant to F. and P.	150	41
Workroom	200	42
General Storage	200	43
Conference Room	200	44
Coffee and Refreshment Bar	50	45
Staff Restroom	300	46
Safe and Vault Room	200	47
Storage	350	48
Ticket Booths	1250	49
Meeting Room	1500	50
Net square footage	10975	
+ 15% circulation	12621	

Administrative
Offices

<u>Area</u>	<u>S.F.</u>	<u>Page No.</u>
Pressboxes	3000	52
Control Rooms	150	53
Television Studio	1000	54
Press Conference Room	1500	55
Restroom Facilities	250	56
Dining Facilities	2000	57
Writers Area	1500	58
Auxiliary Writers Area	600	59
T.V. Camera Platforms	-	
Net square footage	10000	
+ 15% circulation	11500	

Media

<u>Area</u>	<u>S.F.</u>	<u>Page No.</u>
Reception Area	400	61
Owners Office	300	62
Owners Secretary	200	63
Administrative Assistant	225	64
Broadcast Sales Director	275	65
Sales Personell	400	66
Public Relations Assistant	200	67
Director of Broadcasting and Comm.	250	68
Director of Media Services	250	69
Arena Operations Director	225	70
Marketing Secretary	150	71
Director of Player Personell	150	72
Accounting Department Head	250	73
Accounting Department Assistant	175	74
Ticket Manager	200	75
Ticket Clerks	500	76
Secretary for Ticket Sales	175	77
Staff Photographer	150	78
Photographers Darkroom	50	79
Storage Room	200	80
Copy and Print Room	350	81
Coaches Office	350	82
Assistant Coaches Office	250	83
Trainers Office	225	84
Assistant Trainers Office	200	85
Equipment Manager	150	86
Equipment Storage Room	300	87
Trainers Exam Room	400	88
Trainers Exam Storage Room	100	89
Coaches Office Dressing Room	200	90

Franchise Office
Basketball

<u>Area</u>	<u>S.F.</u>	<u>Page No.</u>
Home Dressing Room	1500	91
Shower Room	300	92
Dry Room	150	93
Rest Room	250	94
Visitors Dressing Room	1000	95
Visitors Shower and Dry Room	300	96
Visitors Rest Room	150	97
Visitors Trainers Room	400	98
Conference Room	300	99
Coffee and Refreshment Bar	50	100
Players Conference Room	375	101
Net square footage	12,025	
+ 15% circulation	13,825	

<u>Area</u>	<u>S.F.</u>	<u>Page No.</u>
Reception and Waiting Room	300	103
Receptionist	200	104
Coffee and Refreshment Bar	50	105
Conference Room for Executives	250	106
Conference Room for Organization	500	107
Conference Room for Team	1500	108
Presidents Office	450	109
Presidents Secretary	200	110
Director of Administration	300	112
Media Relations Director	200	113
Marketing and Advertising Media Asst.	150	114
Secretary	700	115
General Manager	300	116
General Manager Secretary	200	117
Player Personell Director	200	118
Player Personell Secretary	150	119
Accounting Director	250	120
Assistant Accounting Director	200	121
Accounting Clerks	750	122
Director of Personell Security	150	123
Ticket Manager	250	124
Ticket Clerks	500	125
Secretary for Ticket Department	175	126
Storage and Workroom	200	127
Copy and Print Room	350	128
Secretary to Coaches	250	129
Head Coaches Office	400	130
Assistant Coaches Offices	2250	131
Coaches Dressing Room	500	132
Equipment Manager	200	133
Equipment Storage Room	350	134

Franchise Office
Football

<u>Area</u>	<u>S.F.</u>	<u>Page No.</u>
Head Trainers Office	250	135
Strength and Conditioning Trainer	200	136
Assistant Trainers	800	137
Staff Photographer	150	138
Photographers Assistant	125	139
Darkroom	50	140
Weight Room	2700	141
Laundry Room	300	143
Home Dressing Room	2500	144
Home Shower and Dry Room	350	145
Home Rest Room	250	146
Home Trainer and Exam Room	700	147
Trainer Exam Room Storage	100	148
Visiting Coaches Dressing Room	350	149
Visiting Dressing Room	2000	150
Visiting Shower and Dry Room	300	151
Visiting Trainers Exam Room	500	152
Visiting Rest Room	200	153
Net square footage	24,250	
+ 15% circulation	27,900	

<u>Area</u>	<u>S.F.</u>	<u>Page No.</u>
Service Entrance	-	155
Trash and Refuse Yard	-	156
Service Yard	-	157
Service Dock, Stadium	450	158
Service Dock, Concessions	450	159
Receiving Rooms	200	160
Commissary	2000	161
Main Storage Facility	4000	162
Restrooms	100	163
Freight Elevator	100	164
Concession Storage Facility	400	165
Service Ramp	-	166
Bulk Storage	5000	167
Janitors Area	500	168
Men Employees Dressing Area	3500	169
Women Employees Dressing Area	3500	170
Employee Equipment Storage	400	171
Boiler Room	10000	172
Air Handling Units	25000	173
Transformer	2000	174
Electrical Closets	10000	175
Arena	100000	176
Livestock Storage Area	10000	177
Net square footage	187,500	
+ 15% circulation	215,625	

Service

SPECTATOR REQUIREMENTS

[Empty rectangular box for spectator requirements]

[Empty rectangular box for spectator requirements]

MULTI-USE SPORTS FACILITY, OKLAHOMA CITY

0

USER: Spectator

FUNCTION/ACTIVITY:

Car parking spaces are for the stadium and the adjoining fairgrounds and is commonly shared

Car Parking

AREA: 9'-0"x 20'-0" 280 s.f./car
35,000-40,000 spaces

HEIGHT:

SPECIAL CONDITIONS:

the parking facility shall be landscaped in a positive manner and be linked to the existing monorail system to provide transportation to the stadium for events.

FINISHES

FLOOR: asphalt

WALLS:

CEILING:

SYSTEMS

LIGHTING: sufficient for exterior parking

PLUMBING:

H VAC:

EQUIPMENT/FURNITURE:

RELATIONSHIPS:

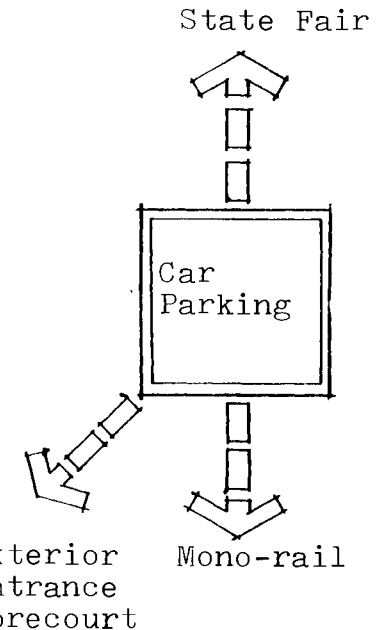

USER: Spectator

FUNCTION/ACTIVITY:

Located at various points along the existing monorail, to be used as a collector and transportation system for the stadium and fairgrounds.

Monorail Drop-off
and Pick-up points

AREA:

HEIGHT:

SPECIAL CONDITIONS:

FINISHES

FLOOR:

WALLS:

CEILING:

SYSTEMS

LIGHTING:

PLUMBING:

H V A C:

EQUIPMENT/FURNITURE:

RELATIONSHIPS:

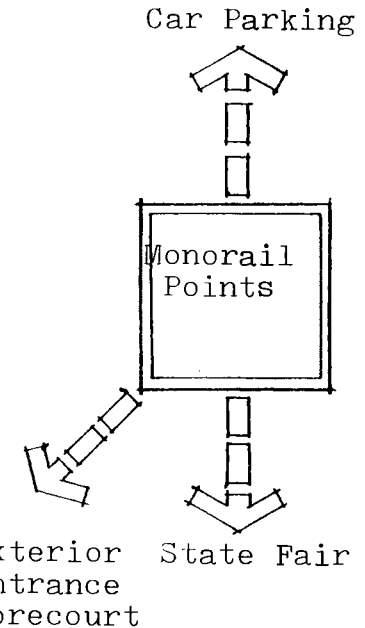

USER: Spectator

FUNCTION/ACTIVITY:

Main public entry into the building during events, an introduction to the new building and should reflect the atmosphere of the fairgrounds

Exterior Entrance
Forecourt

AREA:

HEIGHT:

SPECIAL CONDITIONS:

used as a collector from the fairgrounds proper and the monorail drop-off points

FINISHES

FLOOR: concrete
WALLS: landscaping
CEILING:

SYSTEMS

LIGHTING: exterior court lighting
PLUMBING:
HVAC:

EQUIPMENT/FURNITURE:

seating, exhibits, ticket booths

RELATIONSHIPS:

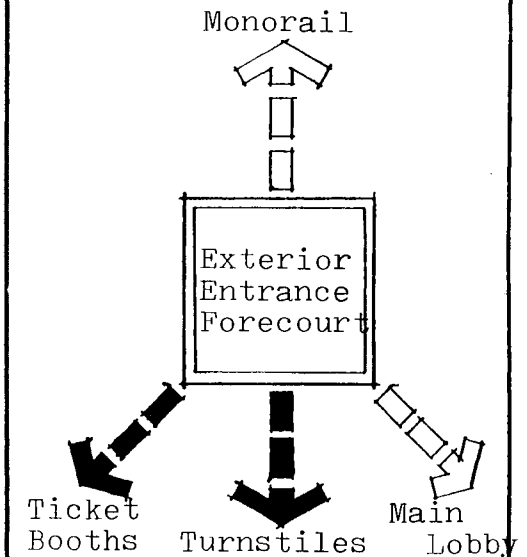

USER: Spectator

FUNCTION/ACTIVITY:

Main entry into the stadium complex. Large enough to accomodate capacity crowds.

Main Lobby

AREA:

HEIGHT: full building height

SPECIAL CONDITIONS:

building connector and dispersing point, also used as a place for spectator orientation.

FINISHES

FLOOR: concrete or ceramic tile
WALLS: concrete block, hard, durable
CEILING: exposed structure.

SYSTEMS

LIGHTING: general, daylighting
PLUMBING: drinking fountains
HVAC: single system

EQUIPMENT/FURNITURE:

seating areas, exhibit space, telephones, drinking fountains.

RELATIONSHIPS:

Turnstiles

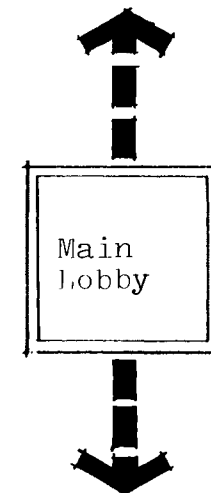

Concourse

USER: Spectator

FUNCTION/ACTIVITY:

The gathering of tickets for controlled entry into the complex for events.

Turnstile

AREA: 50 s.f./turnstile, a turnstile shall serve every 1000 spectators

HEIGHT: 8'-0"

SPECIAL CONDITIONS:

Located at all main entry points into the complex

FINISHES

FLOOR: concrete or ceramic tile
WALLS: concrete block or aluminum panel
CEILING: 2x4 acoustical lay-in tile

SYSTEMS

LIGHTING: general and task
PLUMBING: none
HVAC:

EQUIPMENT/FURNITURE:

counter for the collection of tickets,
25 s.f. storage space

RELATIONSHIPS:

Exterior
Entrance
Forecourt

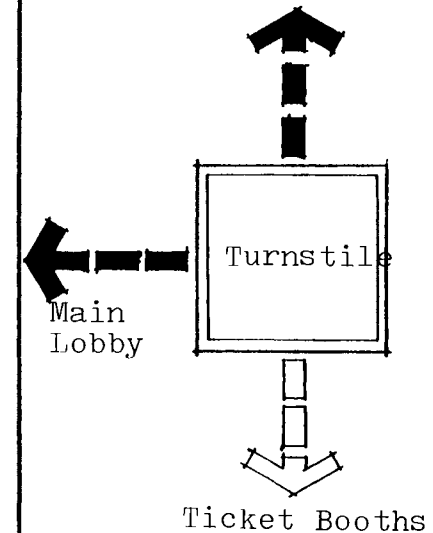

USER: Spectator

FUNCTION/ACTIVITY:

Used for the main pedestrian flow around the stadium with access to the arena seating.

Concourse

AREA:

HEIGHT:

SPECIAL CONDITIONS:

activities of restroom, concessions and services will be in this area.

FINISHES

FLOOR: concrete or tile
WALLS: concrete block
CEILING: exposed structure

SYSTEMS

LIGHTING: general
PLUMBING: drinking fountains
HVAC: single system

EQUIPMENT/FURNITURE:

RELATIONSHIPS:

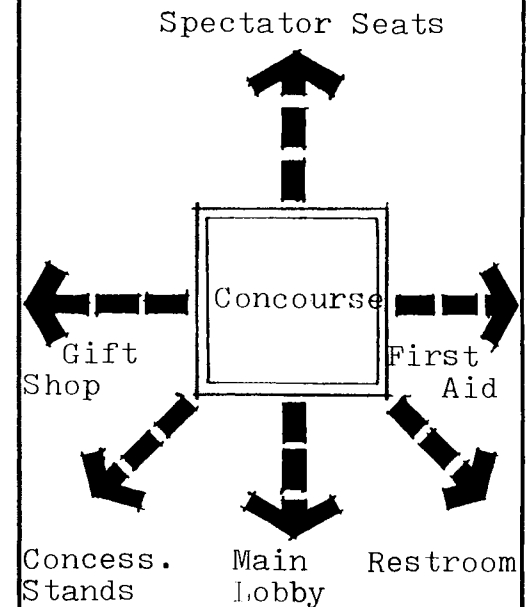

USER: Spectator

FUNCTION/ACTIVITY:
restrooms for the spectator use during
events or games.

Restrooms

AREA:
HEIGHT: 9'-0"
SPECIAL CONDITIONS:

FINISHES
FLOOR: concrete or ceramic tile
WALLS: concrete block
CEILING: exposed structure or gypsum board

SYSTEMS
LIGHTING: general
PLUMBING: toilets, and sinks
HVAC: VAV system

EQUIPMENT/FURNITURE:
urinals, toilets, mirrors, hand blowers
and electrical outlets

RELATIONSHIPS:

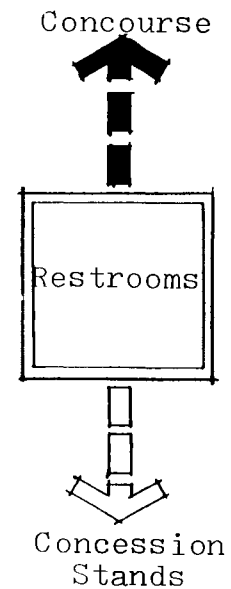

USER: Spectator

FUNCTION/ACTIVITY:

Distribution of concessions during events.

Concession Stands

AREA: 400 s.f. each, need 60, 24,000 s.f.
100 s.f. for every 100 spectators.

HEIGHT: 9'-0"

SPECIAL CONDITIONS:

recessed into alcoves to prevent backup
up patrons into the concourse

FINISHES

FLOOR: concrete
WALLS: concrete block
CEILING: exposed structure

SYSTEMS

LIGHTING: general and task
PLUMBING: sink, as required
HVAC: VAV

EQUIPMENT/FURNITURE:

forty linear feet of counter per stand,
four attendants

RELATIONSHIPS:

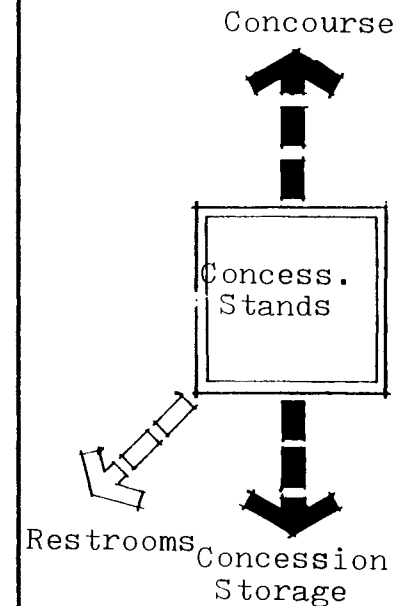

USER: Spectator

FUNCTION/ACTIVITY:
storage for the separate concession
stands.

Concession Stand
Storage

AREA: 100 s.f. per storage unit/concession stand
6000 s.f. total

HEIGHT: 9'-0"

SPECIAL CONDITIONS:

FINISHES

FLOOR: concrete
WALLS: concrete block
CEILING: exposed structure

SYSTEMS

LIGHTING: general
PLUMBING: none
HVAC: none

EQUIPMENT/FURNITURE:

shelves for storage of concession goods,
small refrigerator for perishable concessions

RELATIONSHIPS:

Concession
Storage Facility

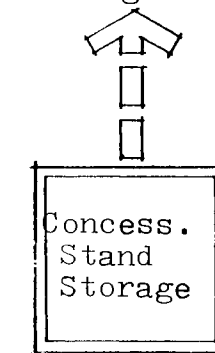

Concession
Stand

USER: Spectator

FUNCTION/ACTIVITY:

For gifts and items for spectators to obtain, sports team memorabilia and special event items.

Gift shop

AREA: 1000 s.f.

HEIGHT: 9'-0"

SPECIAL CONDITIONS:

FINISHES

FLOOR: vinyl tile or concrete

WALLS: concrete block

CEILING: 2x4 acoustical lay-in tile, exposed structure

SYSTEMS

LIGHTING: general

PLUMBING: none

HVAC: VAV with perimeter heating

EQUIPMENT/FURNITURE:

display cabinets of glass, shelves for display, check out counter.

RELATIONSHIPS:

Concourse

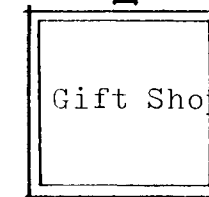

Gift Storage

USER: Spectator

FUNCTION/ACTIVITY:

storage area for the gift shop to store goods for upcoming events and special stock.

Gift Shop Storage

AREA: 150 s.f.

HEIGHT: 9'-0"

SPECIAL CONDITIONS:

FINISHES

FLOOR: concrete
WALLS: concrete block
CEILING: exposed structure.

SYSTEMS

LIGHTING: general
PLUMBING: none
HVAC: none

EQUIPMENT/FURNITURE:

shelves for storage

RELATIONSHIPS:



Gift Shop

USER: Spectator

FUNCTION/ACTIVITY:

For the first aid treatment of minor injuries for spectators and employees during events.

First Aid Treatment

AREA: 150 s.f.

HEIGHT: 9'-0"

SPECIAL CONDITIONS:

located close to ambulance service
also has a toilet and storage room

FINISHES

FLOOR: carpet

WALLS: gypsum board

CEILING: 2x4 acoustical lay-in tile

SYSTEMS

LIGHTING: general and task

PLUMBING: sink

HVAC: VAV with perimeter heating

EQUIPMENT/FURNITURE:

seating for four persons, an exam table
and shelves for equipment,

RELATIONSHIPS:

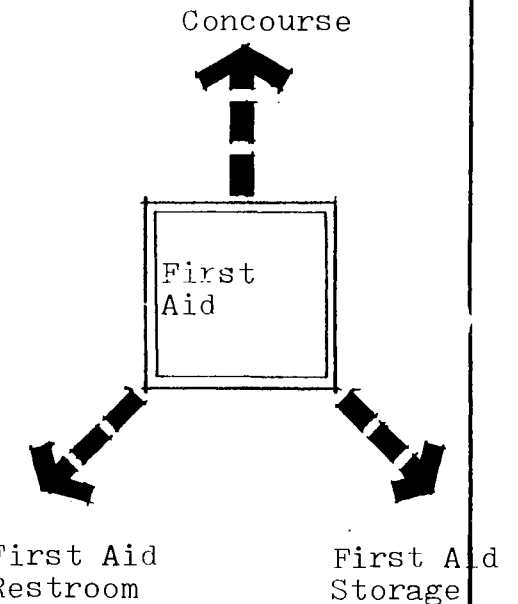

USER: Spectator

FUNCTION/ACTIVITY:

seating for the spectators to be arranged moveable for various events at various scaled events to take place.

Spectator seating

AREA: varies according to layout, 3 s.f./person
55,000-70,000 recommended, 165,000-210,000

HEIGHT:

SPECIAL CONDITIONS:

Box Suites seating is 7,200 s.f.
Season Ticket Holders seating = 15,000 s.f.
which is included in the 210,000 s.f.
total

FINISHES

FLOOR: concrete
WALLS: concrete block
CEILING: exposed structure

SYSTEMS

LIGHTING: general, different lighting for different events
PLUMBING: none
HVAC: single system

EQUIPMENT/FURNITURE:

theater style seating in tier formation.

RELATIONSHIPS:

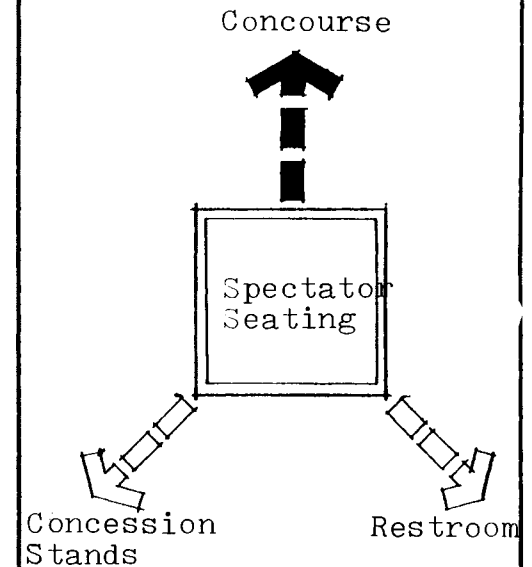

USER: Spectator

FUNCTION/ACTIVITY:

A living type area for spectators used as a gathering area and special seating area for sale during the seasons

Box Suites

AREA: 60 units at 600 s.f. each, 36,000 s.f.

HEIGHT: 8'-0"

SPECIAL CONDITIONS:

Each unit shall have a seating area in front of it for 40 spectators, the seat space is included in spectator seating

FINISHES

FLOOR: Carpet
WALLS: gypsum board
CEILING: 2x4 acoustical lay-in tile

SYSTEMS

LIGHTING: general
PLUMBING: wet bar sink, restroom
HVAC: VAV with perimeter heating

EQUIPMENT/FURNITURE:

wet bar with sink, seating areas, restroom

RELATIONSHIPS:

Concourse

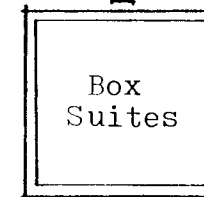

Spectator Seating

USER: Spectator

FUNCTION/ACTIVITY:

Restaurant and eating facility for the staff of the complex and for season ticket holders during events.

Restaurant

AREA: 8,000 s.f.

HEIGHT: 9'-0"

SPECIAL CONDITIONS:

Dining area for season ticket holders and staff

FINISHES

FLOOR: carpet

WALLS: vinyl covered gypsum board

CEILING: 2x4 acoustical lay-in tile

SYSTEMS

LIGHTING: general

PLUMBING: none

HVAC: VAV with perimeter heating

EQUIPMENT/FURNITURE:

Dining tables, chairs for 500, front counter and coat area

RELATIONSHIPS:

Season Ticket seating

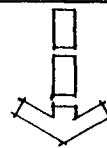

Staff

USER: Spectator

FUNCTION/ACTIVITY:

Refreshment and lounge area for spectators and season ticket holders as well as staff

Lounge

AREA: 4000 s.f.

HEIGHT: 9'0"

SPECIAL CONDITIONS:

Bar and seating

FINISHES

FLOOR: carpet

WALLS: vinyl covered gypsum board

CEILING: 2x4 acoustical lay-in tile

SYSTEMS

LIGHTING: general

PLUMBING: as required for bar

HVAC: VAV with perimeter heating

EQUIPMENT/FURNITURE:

seating and chairs for 500, bar and bar seats.

RELATIONSHIPS:

Spectator seating

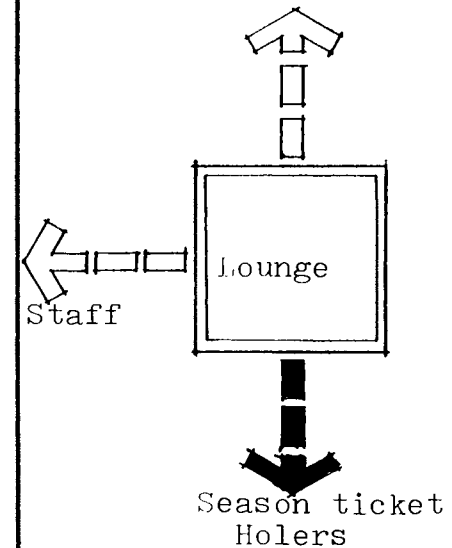

USER: Spectator

FUNCTION/ACTIVITY:

Food preparation facilities for the restaurant

Kitchen

AREA: 2000 s.f.

HEIGHT: 9'-0"

SPECIAL CONDITIONS:

venting for cooking equipment

FINISHES

FLOOR: tile

WALLS: tile

CEILING: gypsum board

SYSTEMS

LIGHTING: task

PLUMBING: as required

HVAC: VAV with perimeter heating
ventilated

EQUIPMENT/FURNITURE:

as required for a kitchen facility

RELATIONSHIPS:



USER: Administration

FUNCTION/ACTIVITY:

For the reception and waiting area of the administration offices. There will be a receptionist to control access and perform general office duties.

Lobby and Reception

AREA: 750 s.f.

HEIGHT: 8'-0"

SPECIAL CONDITIONS:

Location of the facility switchboard

FINISHES

FLOOR: Carpet

WALLS: Gyp board with graphics

CEILING: 2x4 acoustical lay-in

SYSTEMS

LIGHTING: general and task

PLUMBING: none

HVAC: VAV and perimeter heating

EQUIPMENT/FURNITURE:

Receptionist desk with switchboard, counter, and chair, file storage, couch, 4 chairs, coffee and end tables.

RELATIONSHIPS:

Ticket Sales
Business
Accounting

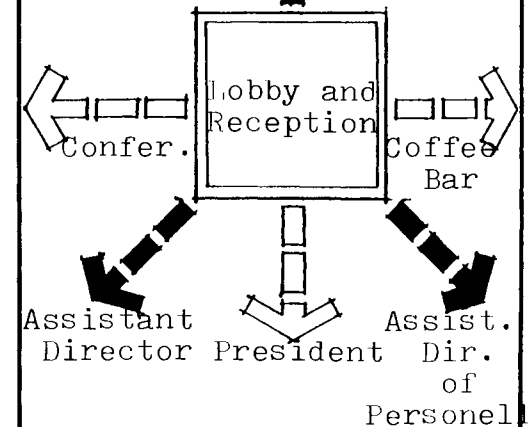

USER: Administration

FUNCTION/ACTIVITY:

Office of the head of the Oklahoma City Sports Complex and overall director of the complex activities.

Presidents Office

AREA: 600 s.f.

HEIGHT: 8'-0"

SPECIAL CONDITIONS:

FINISHES

FLOOR: Carpet
WALLS: gyp board with vinyl covering
CEILING: 2x4 acoustical lay-in

SYSTEMS

LIGHTING: general and task
PLUMBING: wet bar and private bathroom
HVAC: VAV with perimeter heating

EQUIPMENT/FURNITURE:

Executive desk with chair, credenza, small area for informal conferences for four people, one toilet, sink and wetbar.

RELATIONSHIPS:

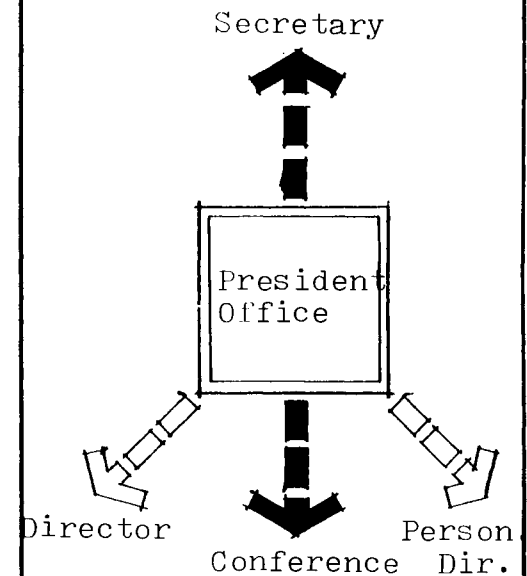

USER: Administration

FUNCTION/ACTIVITY:

secretarial and clerical duties for the president of the administration and the director.

Presidents Secretary

AREA: 250 s.f.

HEIGHT: 9'-0"

SPECIAL CONDITIONS:

FINISHES

FLOOR: carpet
WALLS: gypsum board, vinyl covered
CEILING: 2x4 acoustical lay-in tile

SYSTEMS

LIGHTING: general and task
PLUMBING: none
HVAC: VAV with perimeter heating

EQUIPMENT/FURNITURE:

desk with chair, typing wing
storage and filing cabinets, seating for four, and bookshelves.

RELATIONSHIPS:

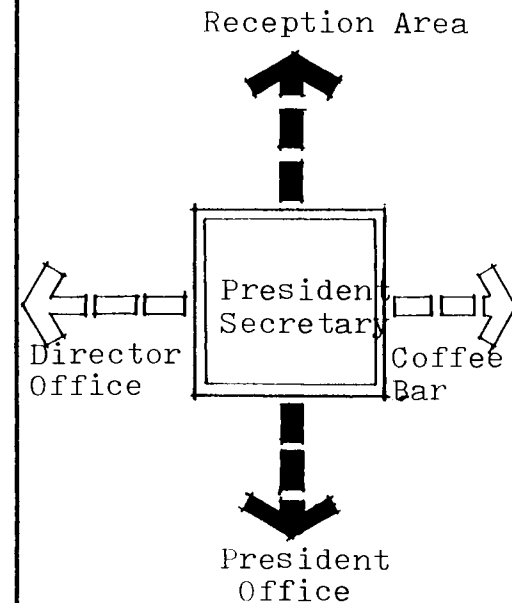

USER: Administration

FUNCTION/ACTIVITY:

Overseer of all functions of the complex and chief administrator helping with the duties of the president

Directors Office

AREA: 300 s.f.

HEIGHT: 8'-0"

SPECIAL CONDITIONS:

FINISHES

FLOOR: carpet

WALLS: gypsum board

CEILING: 2x4 acoustical lay-in tile

SYSTEMS

LIGHTING: general and task

PLUMBING: none

HVAC: VAV with perimeter heating

EQUIPMENT/FURNITURE:

Desk with chair, couch, seating for two, small table and bookshelves.

RELATIONSHIPS:

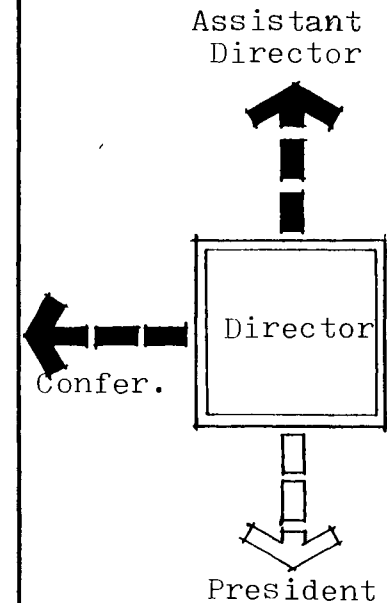

USER: Administration

FUNCTION/ACTIVITY:

Assistant with all duties related to the Director and President

Assistant Director

AREA: 200 s.f.

HEIGHT: 8'-0"

SPECIAL CONDITIONS:

FINISHES

FLOOR: carpet
WALLS: gypsum board
CEILING: 2x4 acoustical lay-in tile

SYSTEMS

LIGHTING: general and task
PLUMBING: none
HVAC: VAV with perimeter heating

EQUIPMENT/FURNITURE:

Desk with chair, credenza, bookshelves, and two side chairs.

RELATIONSHIPS:

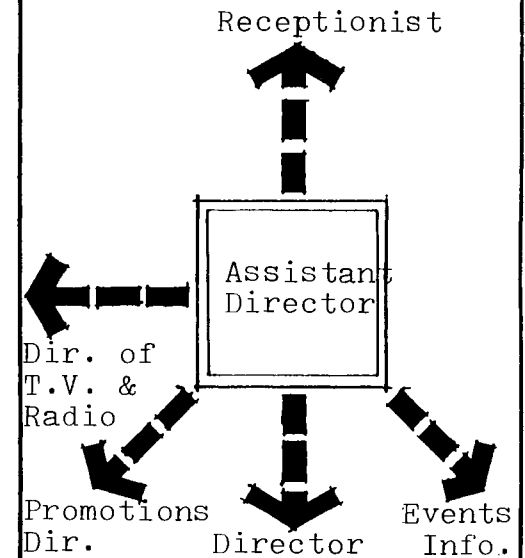

USER: Administration

FUNCTION/ACTIVITY:

Director for the promotion and arrangement of the scheduling of events and activities to coordinate the schedule.

Events Information
Director

AREA: 200 s.f.

HEIGHT: 8'-0"

SPECIAL CONDITIONS:

FINISHES

FLOOR: carpet
WALLS: gypsum board
CEILING: 2x4 acoustical lay-in tile

SYSTEMS

LIGHTING: general and task
PLUMBING: none
HVAC: VAV with perimeter heating

EQUIPMENT/FURNITURE:

Desk with chair, two side chairs, credenza, and bookshelves.

RELATIONSHIPS:

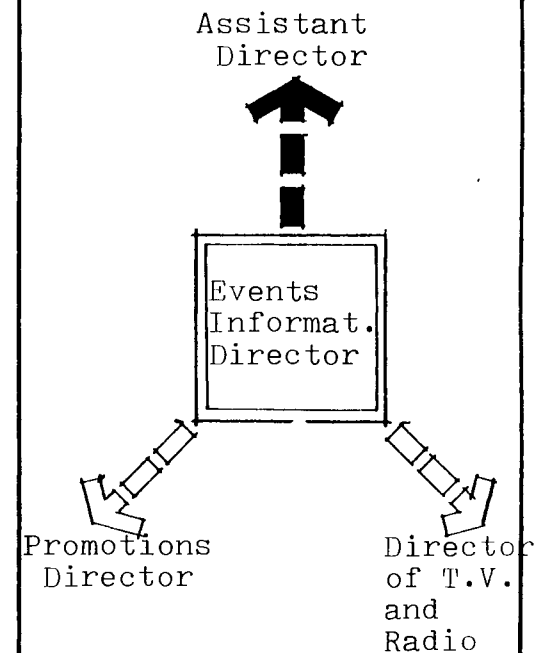

USER: Administration

FUNCTION/ACTIVITY:

Responsibility of Promoting events,
publicity of events and advertisement
of upcoming events.

Promotions Director

AREA: 200 s.f.

HEIGHT: 8'-0"

SPECIAL CONDITIONS:

FINISHES

FLOOR: carpet

WALLS: gypsum board

CEILING: 2x4 acoustical lay-in tile

SYSTEMS

LIGHTING: general and task

PLUMBING: none

HVAC: VAV with perimeter heating

EQUIPMENT/FURNITURE:

desk with chair, credenza, two side chairs
and bookshelves.

RELATIONSHIPS:

Assistant
Director

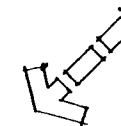

Events
Information
Director

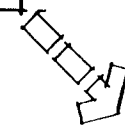

Director
of T.V.
and
Radio

USER: Administration

FUNCTION/ACTIVITY:

Director with relations with television and radio companies for T.V. and Radio arrangements and transactions

Director of Television and Radio Communications

AREA: 200 s.f.

HEIGHT: 8'-0"

SPECIAL CONDITIONS:

FINISHES

FLOOR: carpet
WALLS: gypsum board
CEILING: 2x4 acoustical lay-in tile

SYSTEMS

LIGHTING: general and task
PLUMBING: none
HVAC: VAV with perimeter heating

EQUIPMENT/FURNITURE:

desk with chair, two side chairs, credenza, and bookshelves.

RELATIONSHIPS:

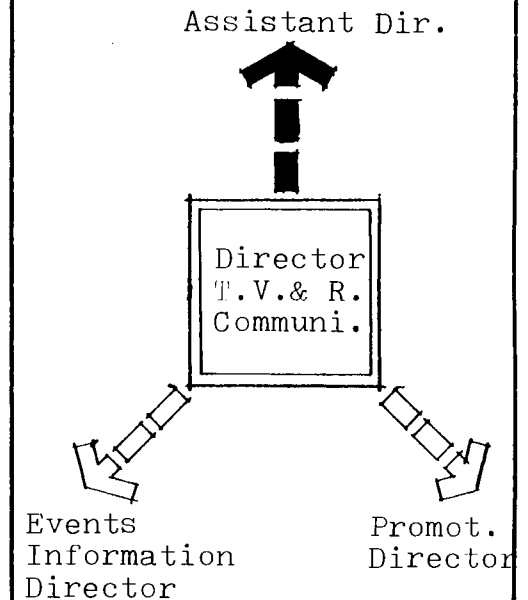

USER: Administration

FUNCTION/ACTIVITY:

Responsible for the maintenance and upkeep of the stadium facilities and hiring employees for maintenance.

Maintenance Director

AREA: 200 s.f.

HEIGHT: 8'-0"

SPECIAL CONDITIONS:

FINISHES

FLOOR: carpet
WALLS: gypsum board
CEILING: 2x4 acoustical lay-in tile

SYSTEMS

LIGHTING: general and task
PLUMBING: none
H V A C: VAV with perimeter heating

EQUIPMENT/FURNITURE:

desk with chair, two side chairs, credenza and bookshelves.

RELATIONSHIPS:

Assistant
Director

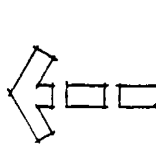

Director of
Facilities
and
Purchasing

USER: Administration

FUNCTION/ACTIVITY:

Responsibility of organizing, ordering,
and distributing of the ticket sales.
Manager of the ticket offices.

Ticket Coordinator

AREA: 200 s.f.

HEIGHT: 8'-0"

SPECIAL CONDITIONS:

FINISHES

FLOOR: carpet
WALLS: gypsum board
CEILING: 2x4 acoustical lay-in tile

SYSTEMS

LIGHTING: general and task
PLUMBING: none
HVAC: VAV with perimeter heating

EQUIPMENT/FURNITURE:

desk with chair, two side chairs, two
filing cabinets and bookshelves.

RELATIONSHIPS:

Ticket Clerical
Clerk

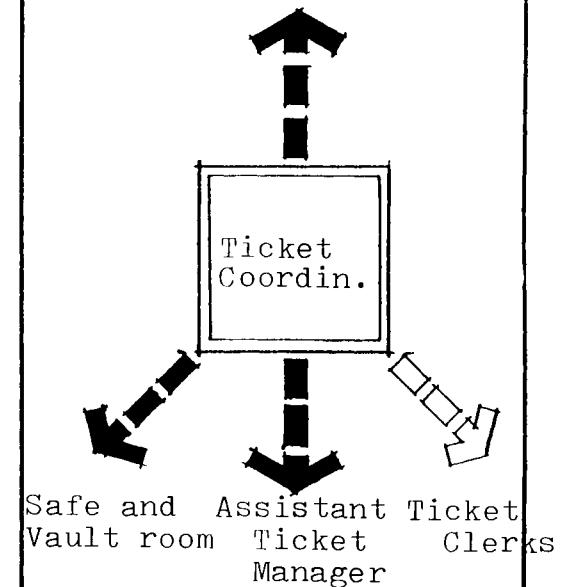

USER: Administration

FUNCTION/ACTIVITY:

Assistant to the ticket coordinator and oversees the ticket clerks and secretary.

Assistant Ticket Manager

AREA: 150 s.f.

HEIGHT: 8'-0"

SPECIAL CONDITIONS:

FINISHES

FLOOR: carpet

WALLS: gypsum board

CEILING: 2x4 acoustical lay-in tile

SYSTEMS

LIGHTING: general and task

PLUMBING: none

HVAC: VAV with perimeter heating

EQUIPMENT/FURNITURE:

desk with chair, two side chairs, filing cabinets with bookshelves.

RELATIONSHIPS:

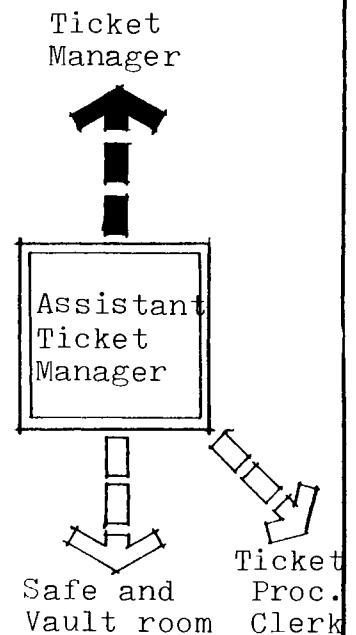

USER: Administration

FUNCTION/ACTIVITY:

Processing of all information received and shipped for filing and storage for the ticket sales department.

Ticket Processing Clerk

AREA: 150 s.f.

HEIGHT: 8'-0"

SPECIAL CONDITIONS:

FINISHES

FLOOR: carpet

WALLS: gypsum board

CEILING: 2x4 acoustical lay-in tile

SYSTEMS

LIGHTING: general and task

PLUMBING: none

HVAC: VAV with perimeter heating

EQUIPMENT/FURNITURE:

desk and chair, two side chairs, table for computer, bookshelves and filing cabinet.

RELATIONSHIPS:

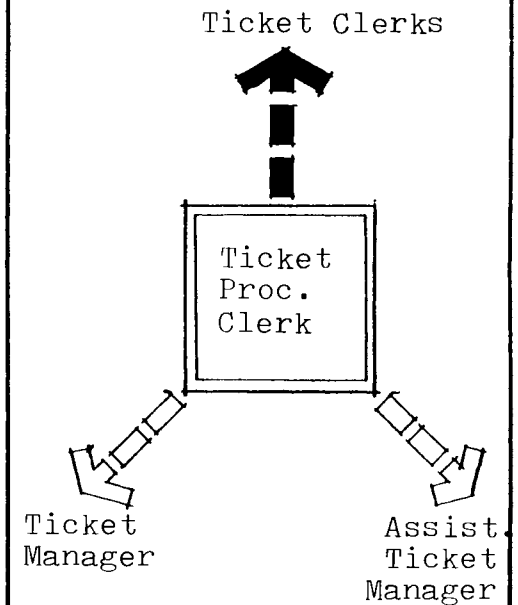

USER: Administration

FUNCTION/ACTIVITY:

Responsible for duties, typing, filing of all information in the ticket sales department.

Ticket Clerical Clerk

AREA: 150 s.f.

HEIGHT: 8'-0"

SPECIAL CONDITIONS:

FINISHES

FLOOR: carpet

WALLS: gypsum board

CEILING: 2x4 acoustical lay-in tile

SYSTEMS

LIGHTING: general and task

PLUMBING: none

HVAC: VAV with perimeter heating

EQUIPMENT/FURNITURE:

desk with chair, side table for computer word processor, two side chairs, bookshelves

RELATIONSHIPS:

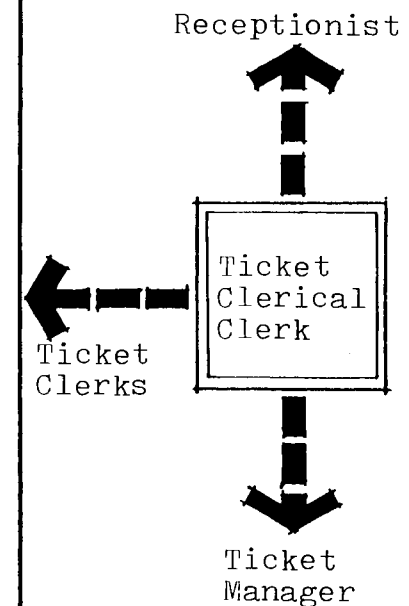

USER: Administration

FUNCTION/ACTIVITY:

Distribution and selling in person, by mail, and group sales of the ticket sales.

Ticket Clerks

AREA: 500 s.f. for five clerks

HEIGHT: 8'-0"

SPECIAL CONDITIONS:

open office type planning

FINISHES

FLOOR: carpet

WALLS: gypsum board

CEILING: 2x4 acoustical lay-in tile

SYSTEMS

LIGHTING: general and task

PLUMBING: none

HVAC: VAV with perimeter heating

EQUIPMENT/FURNITURE:

desk with chairs, upright storage and filing cabinets, ticket sales windows.

RELATIONSHIPS:

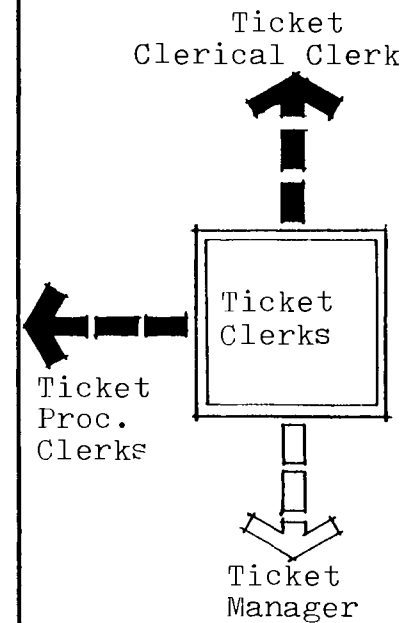

USER: Administration

FUNCTION/ACTIVITY:

Responsibility of keeping the financial records and transactions, employee payroll, and monthly bills for the complex.

Business Manager

AREA: 250 s.f.

HEIGHT: 8'-0"

SPECIAL CONDITIONS:

FINISHES

FLOOR: carpet

WALLS: gypsum board

CEILING: 2x4 acoustical lay-in tile

SYSTEMS

LIGHTING: general and task

PLUMBING: none

HVAC: VAV with perimeter heating

EQUIPMENT/FURNITURE:

desk with chair, two side chairs, couch credenza, and bookshelves.

RELATIONSHIPS:

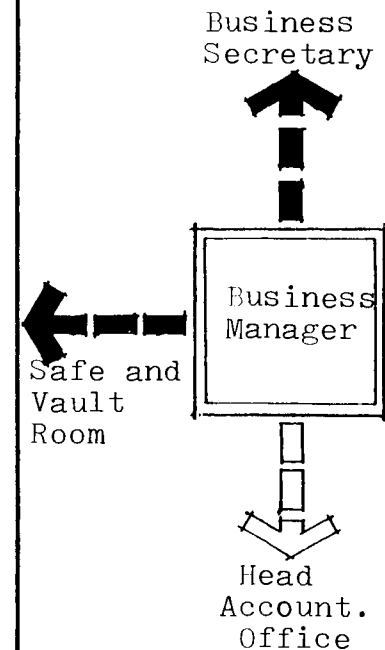

USER: Administration

FUNCTION/ACTIVITY:

filing, typing, clerical duties for the business manager and the accountants

Business Manager
Secretary

AREA: 150 s.f.

HEIGHT: 8'-0"

SPECIAL CONDITIONS:

FINISHES

FLOOR: carpet
WALLS: gypsum board
CEILING: 2x4 acoustical tile

SYSTEMS

LIGHTING: general and task
PLUMBING: none
HVAC: VAV with perimeter heating

EQUIPMENT/FURNITURE:

desk with chair, side table for typing, credenza, and two side chairs, filing and storage cabinets.

RELATIONSHIPS:

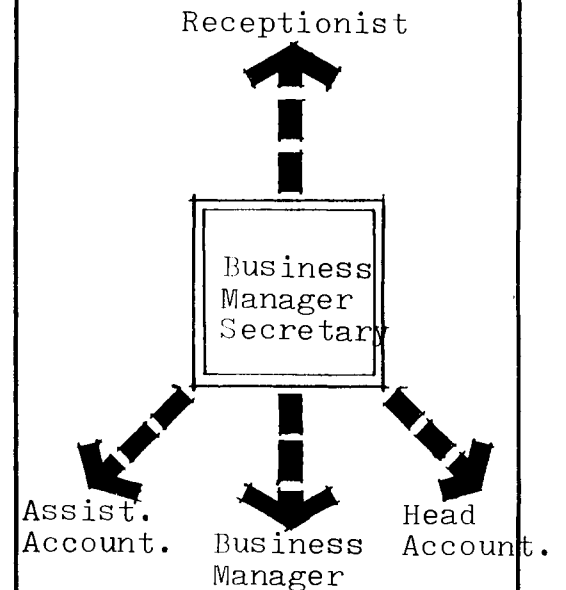

USER: Administration

FUNCTION/ACTIVITY:

Keeps the records of all financial transactions, balances the books, makes payroll checks, and pays bills.

Head Accountant
Office

AREA: 200 s.f.

HEIGHT: 8'-0"

SPECIAL CONDITIONS:

FINISHES

FLOOR: carpet
WALLS: gypsum board
CEILING: 2x4 acoustical lay-in tile

SYSTEMS

LIGHTING: general and task
PLUMBING: none
HVAC: VAV with perimeter heating

EQUIPMENT/FURNITURE:

desk with chair, side table for computer, filing cabinets, two side chairs, bookshelves

RELATIONSHIPS:

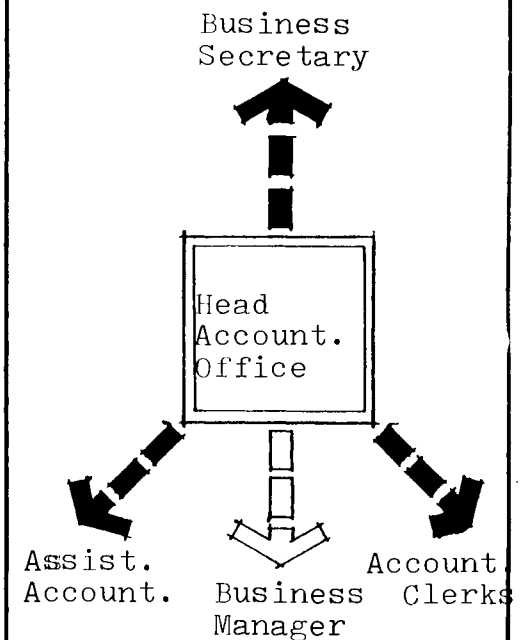

USER: Administration

FUNCTION/ACTIVITY:

Assists the Head Accountant and is in charge of the accounting clerks

Assistant Accounting Director

AREA: 150 s.f.

HEIGHT: 9'-0"

SPECIAL CONDITIONS:

FINISHES

FLOOR: carpet
WALLS: gypsum board
CEILING: 2x4 acoustical lay-in tile

SYSTEMS

LIGHTING: general and task
PLUMBING: none
HVAC: VAV with perimeter heating

EQUIPMENT/FURNITURE:

desk with chair, filing storage,
two side chairs bookshelves

RELATIONSHIPS:

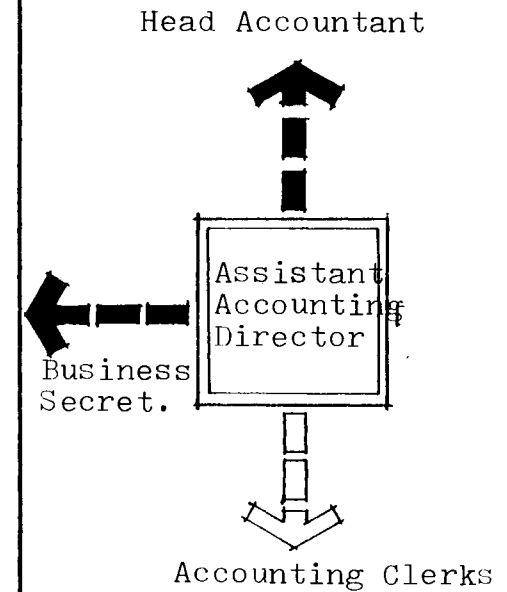

USER: Administration

FUNCTION/ACTIVITY:

Keeping of all the books concerning the time and money of the function of events, ticket sales, parking, and other incomes.

Accounting Offices

AREA: 700 s.f. 4-6 persons

HEIGHT: 8'-0"

SPECIAL CONDITIONS:

open office type planning

FINISHES

FLOOR: carpet

WALLS: gypsum board

CEILING: 2x4 acoustical lay-in tile

SYSTEMS

LIGHTING: general and task

PLUMBING: none

HVAC: VAV with perimeter heating

EQUIPMENT/FURNITURE:

desk with chairs, 3 computer screens, extra chairs, filing and storage cabinets.

RELATIONSHIPS:

Head Accounting Office

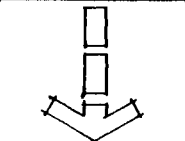
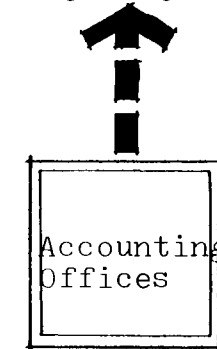

Assistant Accountant

USER: Administration

FUNCTION/ACTIVITY:

Assists with the duties of the Assistant Director of Personell and conducts inter-views for the hiring of additional people.

Personell Manager

AREA: 200 s.f.

HEIGHT: 8'-0"

SPECIAL CONDITIONS:

FINISHES

FLOOR: carpet

WALLS: gypsum board

CEILING: 2x4 acoustical lay-in tile

SYSTEMS

LIGHTING: general and task

PLUMBING: none

HVAC: VAV with perimeter heating

EQUIPMENT/FURNITURE:

desk with chair, credenza, side chairs for two, table for interviewing, and couch

RELATIONSHIPS:

Assistant Dir.
of Personell

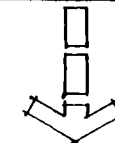
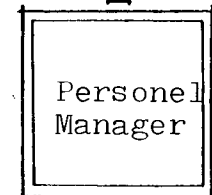

President

USER: Administration

FUNCTION/ACTIVITY:

Oversees all personell responsibilities and is in charge of hiring additional personell for special events and activities.

Assistant Director
Of Personell

AREA: 250 s.f.

HEIGHT: 8'-0"

SPECIAL CONDITIONS:

FINISHES

FLOOR: carpet

WALLS: gypsum board

CEILING: 2x4 acoustical lay-in tile

SYSTEMS

LIGHTING: general and task

PLUMBING: none

HVAC: VAV with perimeter heating

EQUIPMENT/FURNITURE:

desk with chair, credenza, side chairs for two, conference table for four, couch

RELATIONSHIPS:

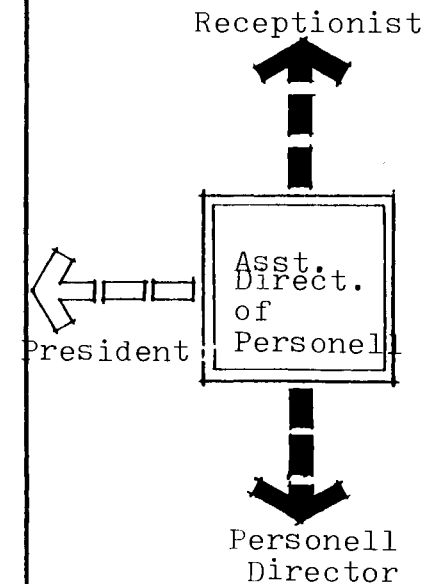

USER: Administration

FUNCTION/ACTIVITY:

Oversees the coordination of events and layout of arena with the scheduling of events, concessions and maintenance goods.

Coordinator of
Facilities and
Purchasing

AREA: 200 s.f.

HEIGHT: 8'-0"

SPECIAL CONDITIONS:

FINISHES

FLOOR: carpet
WALLS: gypsum board
CEILING: 2x4 acoustical lay-in tile

SYSTEMS

LIGHTING: general and task
PLUMBING: none
HVAC: VAV with perimeter heating

EQUIPMENT/FURNITURE:

desk with chair, credenza, two side chairs,
couch and bookshelves.

RELATIONSHIPS:

Assistant
Director



Coordinat.
Of Fac.
and
Purchas.



Administrative
Assistant for
Coordinator of
Facilities and Purch.

USER: Administration

FUNCTION/ACTIVITY:

Assistant to and duties of the coordinator of facilities and purchasing

Administrative Asst.
for Coordinator of
Facilities and Purcha.

AREA: 150 s.f.

HEIGHT: 8'-0"

SPECIAL CONDITIONS:

FINISHES

FLOOR: carpet

WALLS: gypsum board

CEILING: 2x4 acoustical lay-in tile

SYSTEMS

LIGHTING: general and task

PLUMBING: none

H V A C: VAV with perimeter heating

EQUIPMENT/FURNITURE:

desk with chair, two side chairs, credenza,
filing cabinet and bookshelves.

RELATIONSHIPS:

Coordinator of
Facilities and Purch.

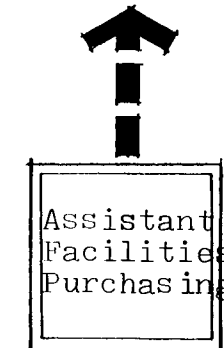

Assistant
Director

USER: Administration

FUNCTION/ACTIVITY:

workroom for the reproduction of documents and xeroxing for the ticket sales depart.

Workroom

AREA: 200 s.f.

HEIGHT: 8'-0"

SPECIAL CONDITIONS:

FINISHES

FLOOR: carpet

WALLS: gypsum board

CEILING: 2x4 acoustical lay-in tile

SYSTEMS

LIGHTING: general and task

PLUMBING: sink

HVAC: VAV with perimeter heating, ventilation

EQUIPMENT/FURNITURE:

shelves and cabinets, xerox machines, storage files

RELATIONSHIPS:

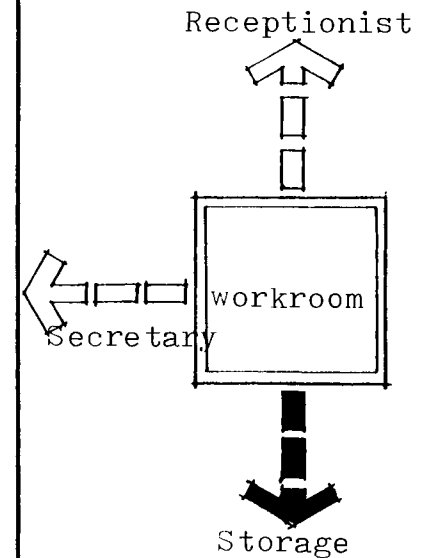

USER: Administration

FUNCTION/ACTIVITY:
General storage area for the ticket sales
area for office supplies and paper mat.

General Storage

AREA: 200 s.f.

HEIGHT: 8'-0"

SPECIAL CONDITIONS:

FINISHES

FLOOR: V.a. tile
WALLS: gypsum board
CEILING: 2x4 acoustical lay-in tile

SYSTEMS

LIGHTING: general
PLUMBING: none
HVAC: none

EQUIPMENT/FURNITURE:

storage shelves and cabinets

RELATIONSHIPS:

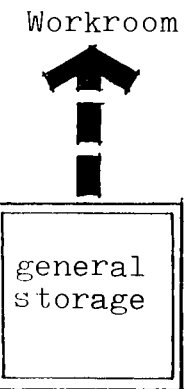

USER: Administration

FUNCTION/ACTIVITY:

conference area for conferences and meetings for the administrative personell.

Conference Room

AREA: 200 s.f. seating for 15 persons.

HEIGHT: 8'-0"

SPECIAL CONDITIONS:

FINISHES

FLOOR: carpet
WALLS: gypsum board
CEILING: 2x4 acoustical lay-in tile

SYSTEMS

LIGHTING: general and task
PLUMBING: sink and wetbar
HVAC: VAV with perimeter heating

EQUIPMENT/FURNITURE:

conference table and seating for fifteen persons, wetbar, slide projector and bookshelves.

RELATIONSHIPS:

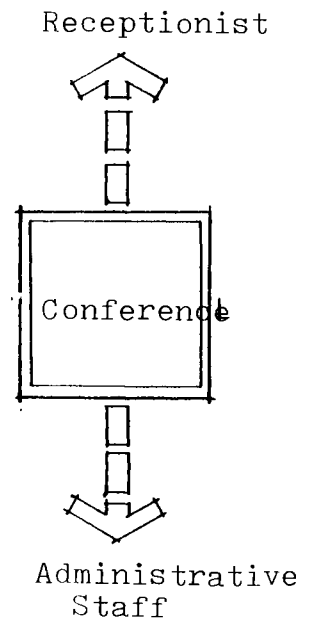

USER: Administration

FUNCTION/ACTIVITY:

Coffee service area to the administration offices and general storage area for refreshment items.

Coffee Bar

AREA: 50 s.f.

HEIGHT: 8'-0"

SPECIAL CONDITIONS:

FINISHES

FLOOR: carpet

WALLS: gypsum board

CEILING: 2x4 acoustical lay-in tile

SYSTEMS

LIGHTING: general

PLUMBING: sink

HVAC: VAV with perimeter heating

EQUIPMENT/FURNITURE:

storage cabinets above and below counter with sink and refrigerator

RELATIONSHIPS:

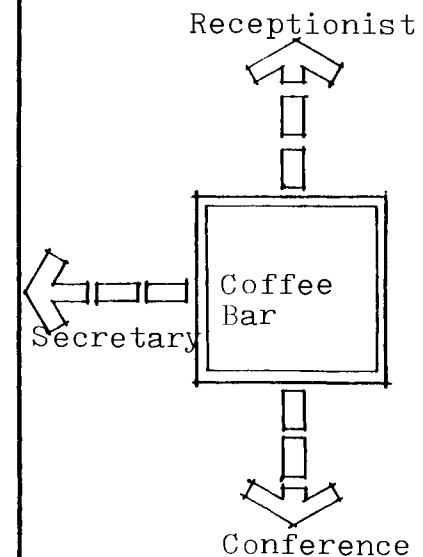

USER: Administration

FUNCTION/ACTIVITY:

Provide service to all the staff in the administrative area.

Staff Restroom

AREA: 300 s.f. for men and women

HEIGHT: 8'-0"

SPECIAL CONDITIONS:

FINISHES

FLOOR: ceramic tile

WALLS: ceramic tile

CEILING: gypsum board

SYSTEMS

LIGHTING: general

PLUMBING: washroom fixtures

HVAC:

EQUIPMENT/FURNITURE:

women: two toilets, two sinks, mirrors
shelf and hand dryer

Men : two toilets, two sinks, mirrors,
shelf and hand dryer.

RELATIONSHIPS:

Administrative
Staff

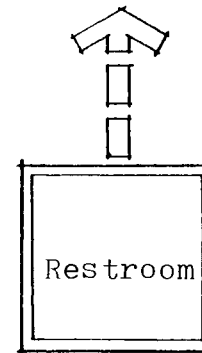

USER: Administration

FUNCTION/ACTIVITY:

a safe and vault to safely keep financial records of transactions and important document and money for the ticket sales department.

Safe and Vault Room

AREA: 200 s.f.

HEIGHT: 8'-0"

SPECIAL CONDITIONS:

security must be maximum

FINISHES

FLOOR: carpet
WALLS: concrete
CEILING: concrete

SYSTEMS

LIGHTING: general
PLUMBING: none
HVAC: VAV

EQUIPMENT/FURNITURE:

RELATIONSHIPS:

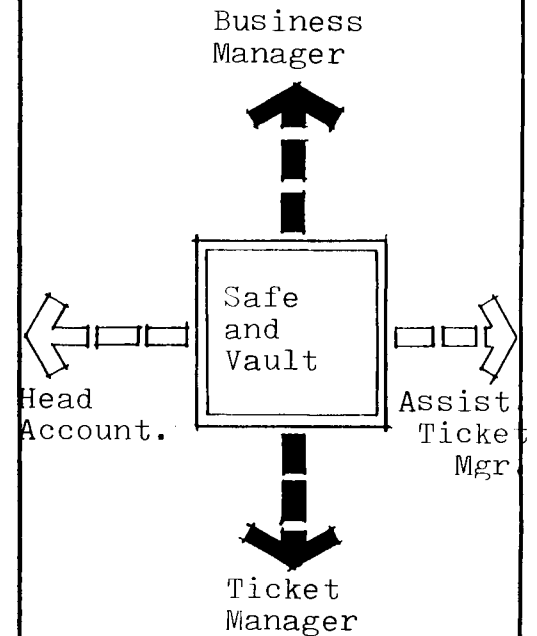

USER: Administration

FUNCTION/ACTIVITY:

Storage for general items and advance ticket sales boards, tickets, and posters.

Storage Room

AREA: 350 s.f.

HEIGHT: 8'-0"

SPECIAL CONDITIONS:

FINISHES

FLOOR: carpet or va tile
WALLS: gypsum board
CEILING: 2x4 acoustical lay-in tile

SYSTEMS

LIGHTING: general
PLUMBING: sink
HVAC: VAV with perimeter heating

EQUIPMENT/FURNITURE:

shelf and storage cabinets above and below counter, upright storage cabinets for material storage.

RELATIONSHIPS:

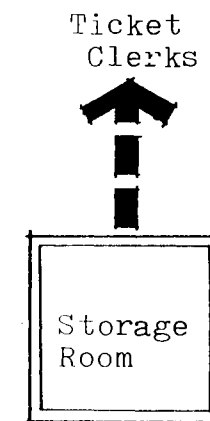

USER: Administration

FUNCTION/ACTIVITY:

Selling of tickets to the public for upcoming activities and events.

Ticket Booths

AREA: 50 s.f./ booth, 25 booths, 1,250 s.f.

HEIGHT: 8'-0"

SPECIAL CONDITIONS:

could be separated from the building and freestanding in the exterior court area

FINISHES

FLOOR: va tile

WALLS: gypsum board

CEILING: 2x4 acoustical lay-in tile

SYSTEMS

LIGHTING: general and task

PLUMBING: none

HVAC: VAV with perimeter heating

EQUIPMENT/FURNITURE:

counter for public ticket sales, chair, storage anrea and money drawer.

RELATIONSHIPS:

Ticket Department

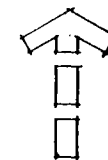

Ticket Booths

Exterior Entrance Forecourt

USER: Administration

FUNCTION/ACTIVITY:

Meeting area for the administration of the complex for news conferences and organizational meetings

Meeting room

AREA: 1500 s.f.

HEIGHT: 9'-0"

SPECIAL CONDITIONS:

FINISHES

FLOOR: carpet

WALLS: gypsum board

CEILING: 2x4 acoustical lay-in tile

SYSTEMS

LIGHTING: general

PLUMBING: none

HVAC: VAV with perimeter heating

EQUIPMENT/FURNITURE:

seating for 150 persons with viewing capabilities.

RELATIONSHIPS:

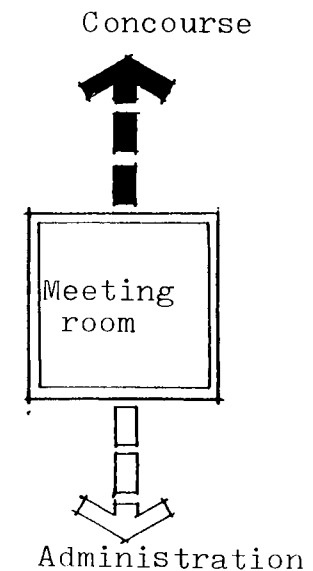

USER: Media

FUNCTION/ACTIVITY:

For the recording and taping of events by the various media. Used by television and radio by broadcasters and sports announcers along with technicians.

Pressboxes

AREA: 200 s.f. each, 15 boxes at 3000 s.f.

HEIGHT: 8'-0" back stepping to 12'-0" front

SPECIAL CONDITIONS:

Located at intermediate level with a clear view to the sports and activity area.

FINISHES

FLOOR: Carpet
WALLS: Gypsum board with sound insulation
CEILING: 2x4 acoustical lay-in

SYSTEMS

LIGHTING: general and task
PLUMBING: none
HVAC: VAV with perimeter heating

EQUIPMENT/FURNITURE:

Three rows of three feet wide tables with seating, storage space at back, television monitor.

RELATIONSHIPS:

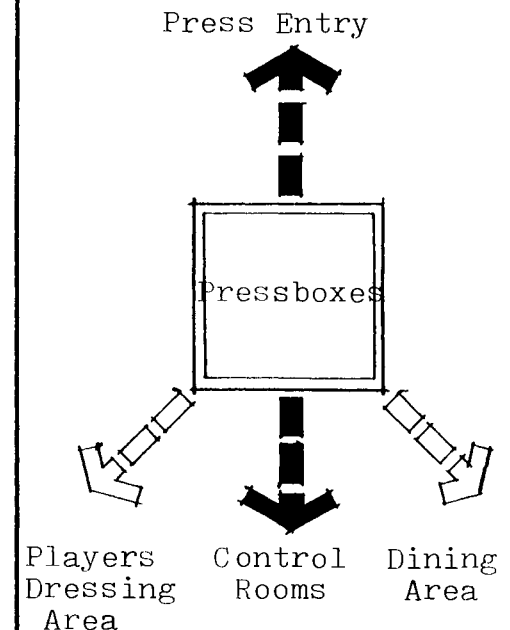

USER: Media

FUNCTION/ACTIVITY:

To control the signals and broadcasts from the television and radio pressboxes and direct them to their various stations.

Control Room

AREA: 50 s.f., one for every five (5) pressboxes

HEIGHT: 8'-0"

SPECIAL CONDITIONS:

Close relation to the pressboxes

FINISHES

FLOOR: Carpet

WALLS: Gypsum board with sound insulation

CEILING: 2x4 acoustical lay-in tile

SYSTEMS

LIGHTING: general and task

PLUMBING: none

HVAC: VAV with perimeter heating

EQUIPMENT/FURNITURE:

control desk and chair with control panel.

RELATIONSHIPS:

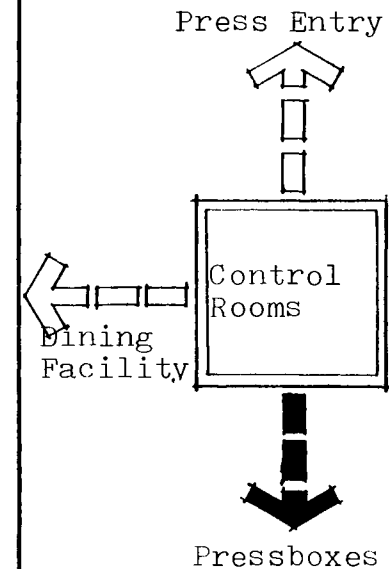

USER: Media

FUNCTION/ACTIVITY:

For the broadcast of events live and the interviewing of VIP and players.

Television Studio

AREA: 1000 s.f.

HEIGHT: 12'-0"

SPECIAL CONDITIONS:

FINISHES

FLOOR: Carpet and/or VA tile
WALLS: Gypsum board with sound insulation
CEILING: 2x4 acoustical lay-in tile

SYSTEMS

LIGHTING: as required for television broadcasts
PLUMBING: none
HVAC: VAV with perimeter heating

EQUIPMENT/FURNITURE:

Seating area for 4-5 persons to be interviewed and an area for camera and equipment for a team of 4 engineers.

RELATIONSHIPS:

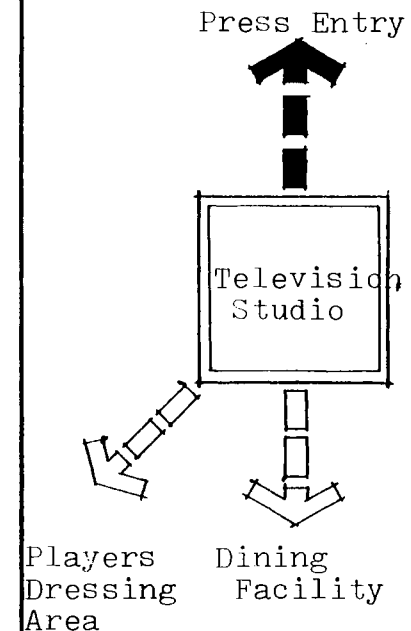

USER: Media

FUNCTION/ACTIVITY:

For the gathering of the media for special bulletins and announcements distributed by officials of the team and stadium and a gathering place for the media prior to events.

Press Conference Room

AREA: 1500 s.f.

HEIGHT: 9'-0"

SPECIAL CONDITIONS:

FINISHES

FLOOR: Carpet
WALLS: Gypsum Board
CEILING: 2x4 acoustical lay-in tile

SYSTEMS

LIGHTING: general
PLUMBING: none
HVAC: VAV with perimeter heating

EQUIPMENT/FURNITURE:

seating for 100 media persons with a main podium for announcements and visual showing capabilities.

RELATIONSHIPS:

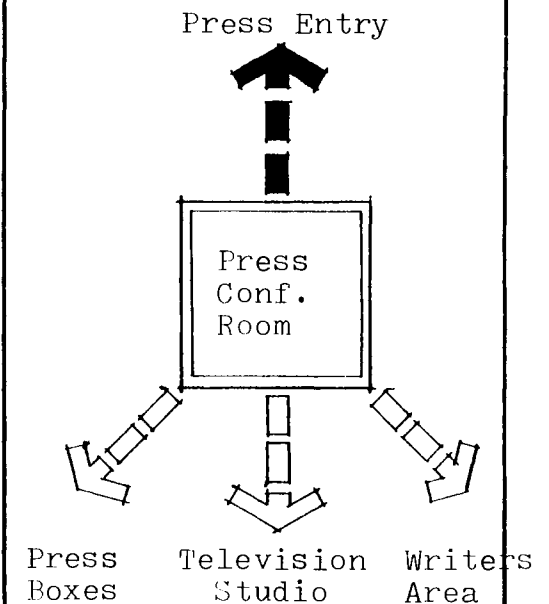

USER: Media

FUNCTION/ACTIVITY:

For use by the media personell and guests

Restrooms

AREA: 250 s.f., men and women combined

HEIGHT: 8'-0"

SPECIAL CONDITIONS:

FINISHES

FLOOR: Ceramic tile

WALLS: Ceramic tile

CEILING: Gypsum Board

SYSTEMS

LIGHTING: general

PLUMBING: women 4 w.c. 3 sink, men 2 w.c. 2 ur. 3 sink

HVAC: VAV with perimeter heating, ventilation

EQUIPMENT/FURNITURE:

mirrors, hand dryers, shelf below mirror
in womens

RELATIONSHIPS:

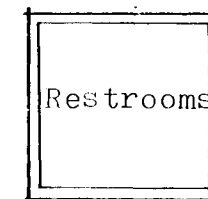

Dining
Facility

USER: Media

FUNCTION/ACTIVITY:

for the dining and concessions of the media

Dining facility

AREA: accomodate 200 at 10 s.f./person, 2000 s.f.

HEIGHT: 9'-0"

SPECIAL CONDITIONS:

FINISHES

FLOOR: Concrete
WALLS: gyp board
CEILING: exposed structure or 2x4 lay-in

SYSTEMS

LIGHTING: general
PLUMBING: drinking fountain, sink
HVAC: VAV with perimeter heating

EQUIPMENT/FURNITURE:

dining tables and seating for 200 persons.

RELATIONSHIPS:

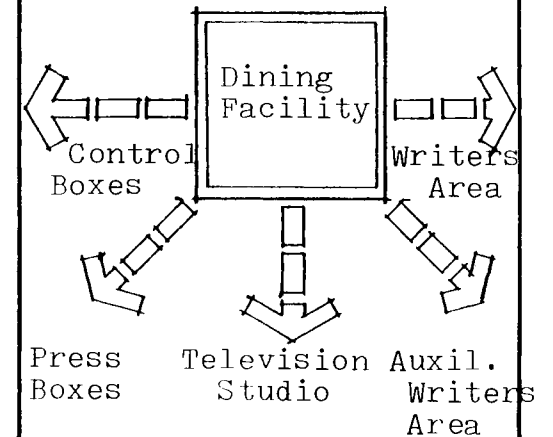

USER: Media

FUNCTION/ACTIVITY:

For the use of the newspaper writers and reporters to comment on the events

Writers Area

AREA: 1500 s.f. to accomodate 70 writers

HEIGHT: 8'-0" - 12'-0"

SPECIAL CONDITIONS:

FINISHES

FLOOR: Carpet

WALLS: gyp board with sound insulation

CEILING: 2x4 acoustical lay-in tile

SYSTEMS

LIGHTING: general and task

PLUMBING: none

HVAC: VAV with perimeter heating

EQUIPMENT/FURNITURE:

tables and seating for 70 writers, a writers table shall be 3'-5' and a storage area for coats and other items shall be in back.

RELATIONSHIPS:

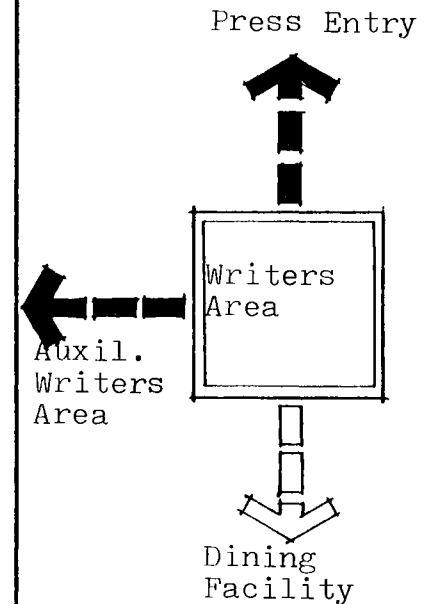

USER: Media

FUNCTION/ACTIVITY:

For the use in case of overflow writers in special events are necessary. Used by writers for newspapers and magazines reporters for special events.

Auxiliary Writers Area

AREA: 600 s.f. to accomodate 30 writers

HEIGHT: 8'-0" - 12'-0"

SPECIAL CONDITIONS:

FINISHES

FLOOR: Carpet
WALLS: gypsum board with sound insulation
CEILING: 2x4 acoustical lay-in tile

SYSTEMS

LIGHTING: general and task
PLUMBING: none
HVAC: VAV with perimeter heating

EQUIPMENT/FURNITURE:

tables and seating for 30 writers, a writer table shall be 3'-5' and a storage area for coats and other items shall be in back.

RELATIONSHIPS:

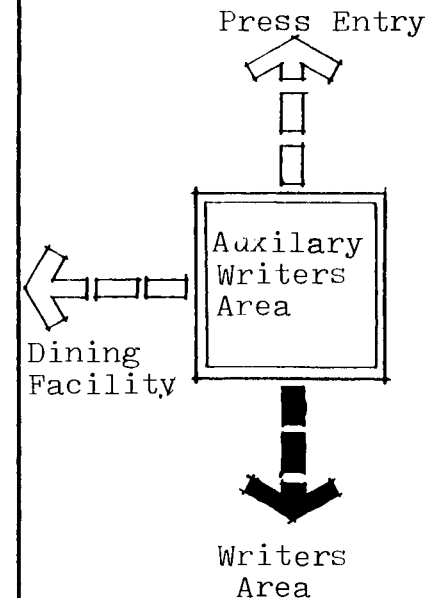

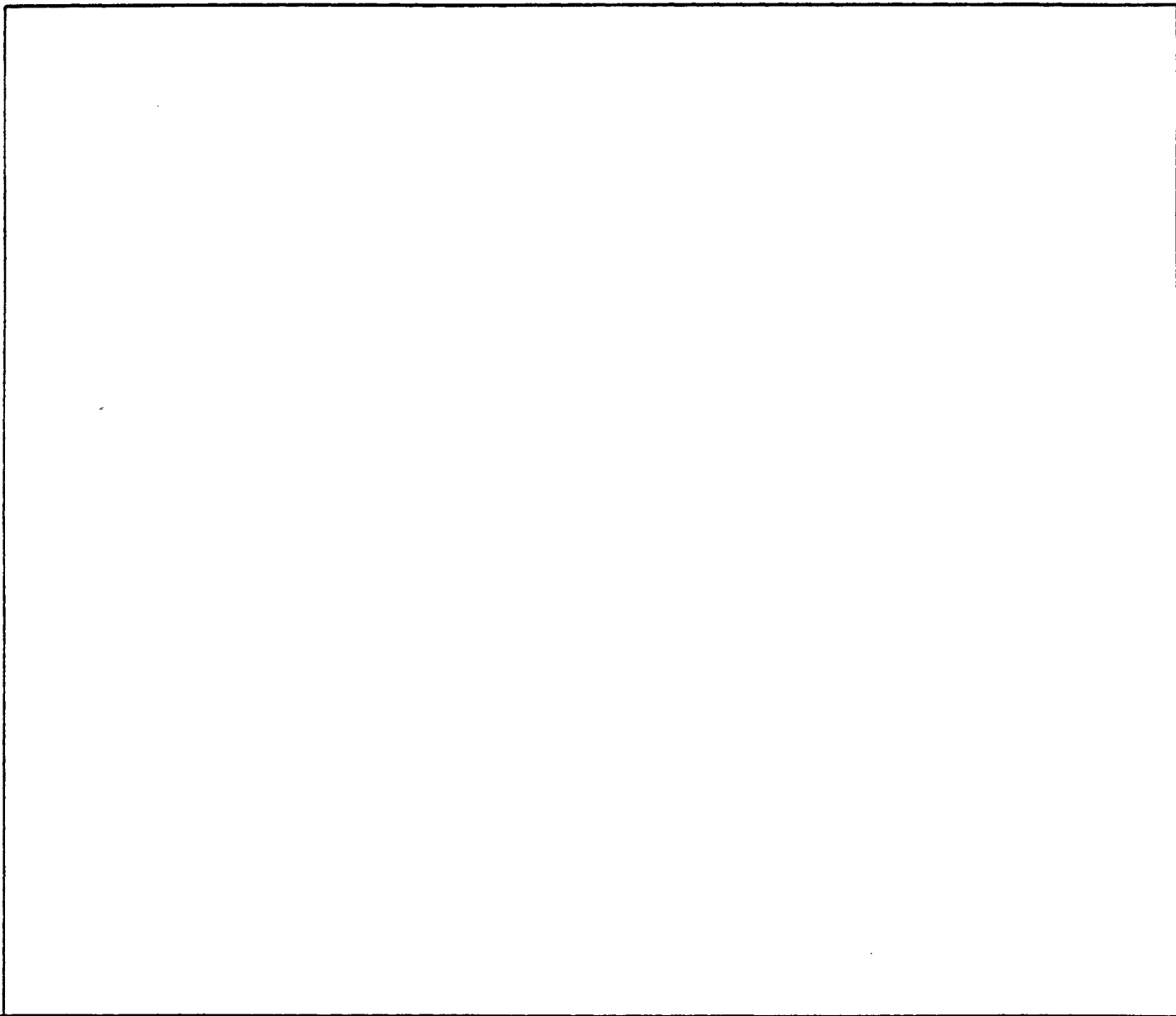
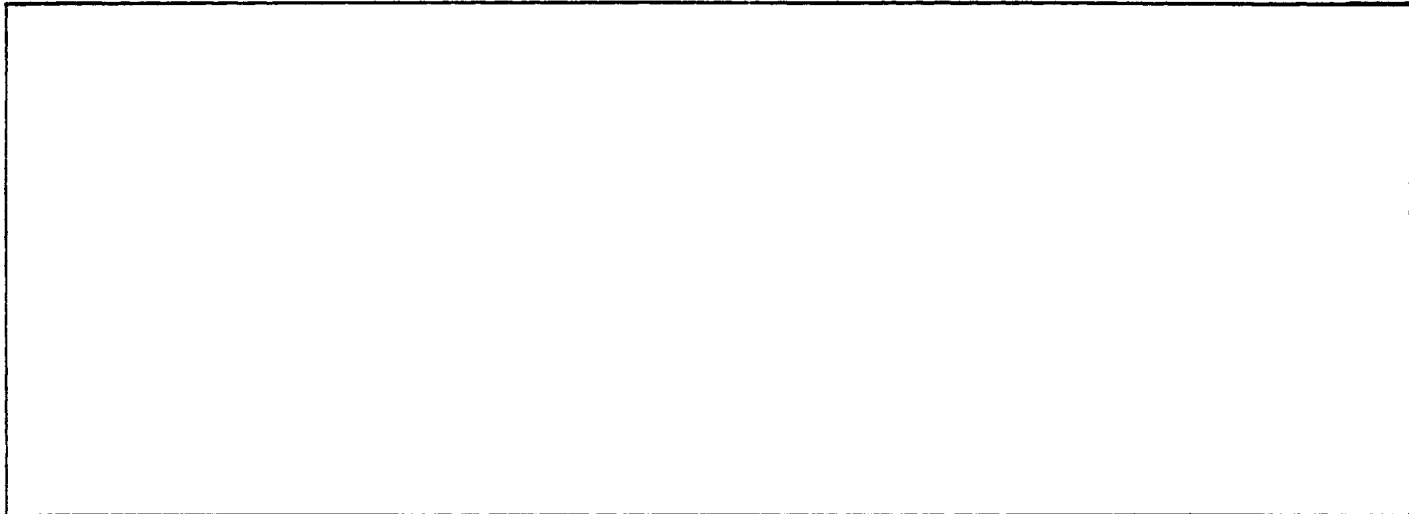

USER: Franchise Office, Basketball

FUNCTION/ACTIVITY:

Reception and waiting area for persons with business meetings for the players and organization.

Reception Area

AREA: 400 s.f.

HEIGHT: 3'-0"

SPECIAL CONDITIONS:

FINISHES

FLOOR: carpet
WALLS: gypsum board with graphics
CEILING: 2x4 acoustical lay-in tile

SYSTEMS

LIGHTING: general and task
PLUMBING: none
HVAC: VAV with perimeter heating

EQUIPMENT/FURNITURE:

seating area for four, couch, tables, receptionist desk and chair.

RELATIONSHIPS:

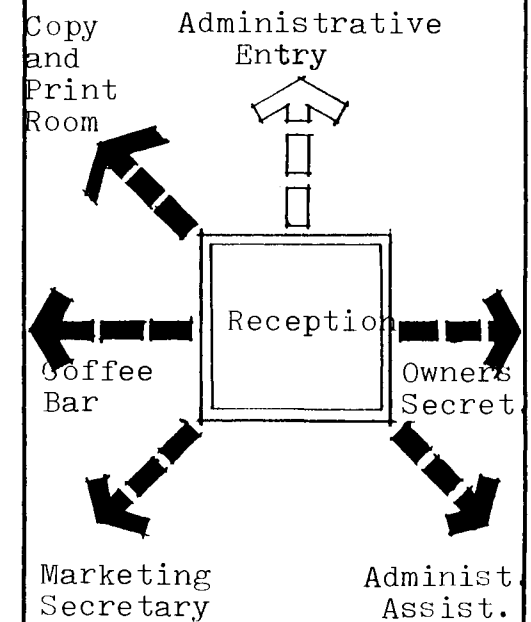

USER: Franchise Office, Basketball

FUNCTION/ACTIVITY:

President and overall manager of the organization.

Owners Office

AREA: 400 s.f.

HEIGHT: 8'-0"

SPECIAL CONDITIONS:

FINISHES

FLOOR: carpet
WALLS: gyp. board with vinyl wall covering
CEILING: 2x4 acoustical lay-in tile

SYSTEMS

LIGHTING: general and task
PLUMBING: wet bar with sink, toilet
HVAC: VAV with perimeter heating

EQUIPMENT/FURNITURE:

Executive desk with chair, credenza, two side chairs, couch, conference table for four and bookshelves.

RELATIONSHIPS:

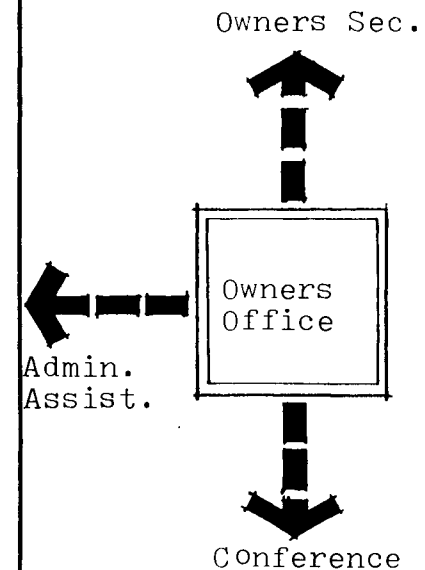

USER: Franchise Office, Basketball

FUNCTION/ACTIVITY:
Secretarial and clerical responsibilities
and receptionist for the general
manager.

Owners
Secretary

AREA: 200 s.f.

HEIGHT: 8'-0"

SPECIAL CONDITIONS:

FINISHES

FLOOR: carpet
WALLS: gypsum board
CEILING: 2x4 acoustical lay-in tile

SYSTEMS

LIGHTING: general and task
PLUMBING: none
HVAC: VAV with perimeter heating

EQUIPMENT/FURNITURE:

desk with chair, typing wing, two side
chairs, couch

RELATIONSHIPS:

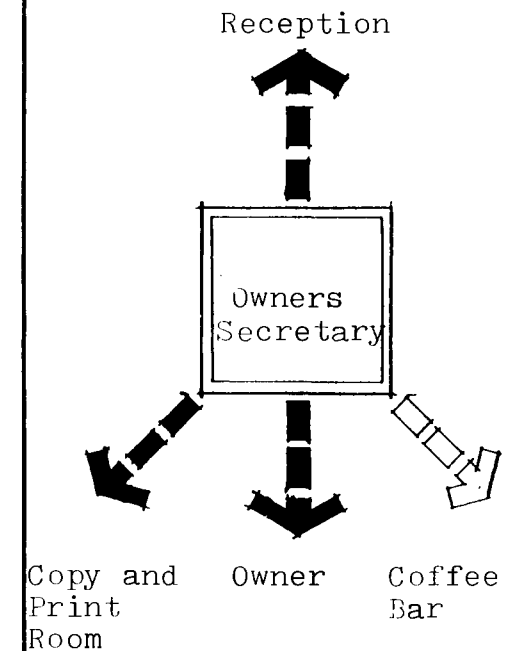

USER: Franchise Office, Basketball

FUNCTION/ACTIVITY:

Assistant to the general manager and the administrative personell.

Administrative Assistant

AREA: 225 s.f.

HEIGHT: 8'-0"

SPECIAL CONDITIONS:

FINISHES

FLOOR: carpet
WALLS: gypsum board
CEILING: 2x4 acoustical lay-in tile

SYSTEMS

LIGHTING: general and task
PLUMBING: none
HVAC: VAV with perimeter heating

EQUIPMENT/FURNITURE:

desk with chair, two side chairs, credenza bookshelves.

RELATIONSHIPS:

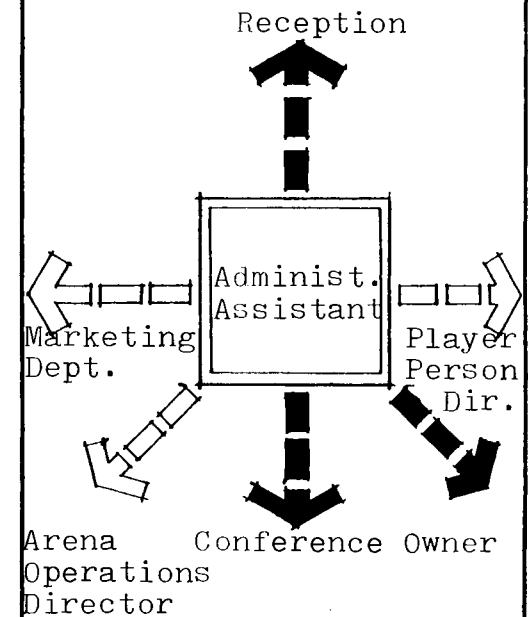

USER: Franchise Office, Basketball

FUNCTION/ACTIVITY:

Works closely with the Director of Media Services on Sales of Broadcasting rights

Broadcast Sales Director

AREA: 275 s.f.

HEIGHT: 8'-0"

SPECIAL CONDITIONS:

FINISHES

FLOOR: carpet

WALLS: gypsum board

CEILING: 2x4 acoustical lay-in tile

SYSTEMS

LIGHTING: general and task

PLUMBING: none

HVAC: VAV with perimeter heating

EQUIPMENT/FURNITURE:

desk with chair, conference table for four, two side chairs, bookshelves.

RELATIONSHIPS:

Marketing Sec.



Sales Personell

USER: Franchise Office, Basketball

FUNCTION/ACTIVITY:

Duties of selling advertisement and promotional rights connected with the organization.

Sales Personell

AREA: 200 s.f. each, 2 needed, 400 s.f.

HEIGHT: 8'-0"

SPECIAL CONDITIONS:

FINISHES

FLOOR: carpet
WALLS: gypsum board
CEILING: 2x4 acoustical lay-in tile

SYSTEMS

LIGHTING: general and task
PLUMBING: none
HVAC: VAV with perimeter heating

EQUIPMENT/FURNITURE:

desk with chair, two side chairs,
bookshelves

RELATIONSHIPS:

Marketing Sec.



Broadcasting
Sales
Director

USER: Franchise Office, Basketball

FUNCTION/ACTIVITY:

Assistant to the Director of Broadcasting and Communications and Director of Media Services.

Public Relations Assistant

AREA: 200 s.f.

HEIGHT: 8'-0"

SPECIAL CONDITIONS:

FINISHES

FLOOR: Carpet

WALLS: gypsum board

CEILING: 2x4 acoustical lay-in tile

SYSTEMS

LIGHTING: general and task

PLUMBING: none

HVAC: VAV with perimeter heating

EQUIPMENT/FURNITURE:

desk with chair, two side chairs, bookshelves and upright storage.

RELATIONSHIPS:

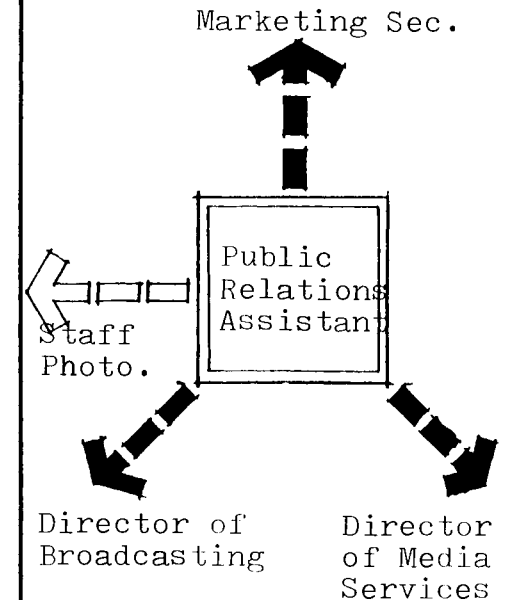

USER: Franchise Office, Basketball

FUNCTION/ACTIVITY:

Assistant to the director of Media Services and works with the Radio and Television companies on set-up of booths and broadcasting

Director of Broadcasting and Communications

AREA: 250 s.f.

HEIGHT: 8'-0"

SPECIAL CONDITIONS:

FINISHES

FLOOR: carpet
WALLS: gypsum board
CEILING: 8'-0"

SYSTEMS

LIGHTING: general and task
PLUMBING: none
HVAC: VAV with perimeter heating

EQUIPMENT/FURNITURE:

desk with chair, two side chairs, couch credenza, and bookshelves

RELATIONSHIPS:

Public Relations Assistant



Director of Broadcasting and Communic.

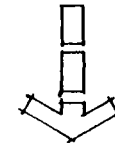

Director of Media Services

USER: Franchise Office, Basketball

FUNCTION/ACTIVITY:

Director of and overseer of all media related activities, coordinator of contracts and set-up of booths.

Director of Media Services

AREA: 250 s.f.

HEIGHT: 8'-0"

SPECIAL CONDITIONS:

FINISHES

FLOOR: carpet
WALLS: gypsum board
CEILING: 2x4 acoustical lay-in tile

SYSTEMS

LIGHTING: general and task
PLUMBING: none
HVAC: VAV with perimeter heating

EQUIPMENT/FURNITURE:

desk with chair, two side chairs, credenza and bookshelves.

RELATIONSHIPS:

Public Relations Assistant

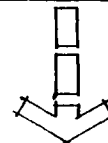
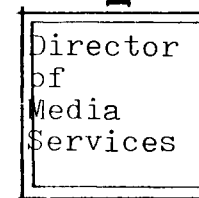

Director of Broadcasting and Communications

USER: Franchise Office, Basketball

FUNCTION/ACTIVITY:

Coordinates with the administration the setting up of the arena for activities and events

Arena Operations
Director

AREA: 225 s.f.

HEIGHT: 8'-0"

SPECIAL CONDITIONS:

FINISHES

FLOOR: carpet
WALLS: gypsum board
CEILING: 2x4 acoustical lay-in tile

SYSTEMS

LIGHTING: general and task
PLUMBING: none
HVAC: VAV with perimeter heating

EQUIPMENT/FURNITURE:

desk with chair, two side chairs, bookshelves

RELATIONSHIPS:

Receptionist



Administrative
Assistant

USER: Franchise Office, Basketball

FUNCTION/ACTIVITY:

Secretarial and clerical duties under personell in the Marketing Department

Marketing Secretary

AREA: 150 s.f.

HEIGHT: 8'-0"

SPECIAL CONDITIONS:

FINISHES

FLOOR: carpet
WALLS: gypsum board
CEILING: 2x4 acoustical lay-in tile

SYSTEMS

LIGHTING: general and task
PLUMBING: none
HVAC: VAV with perimeter heating

EQUIPMENT/FURNITURE:

desk with chair, typing wing, two side chairs, storage and filing cabinets.

RELATIONSHIPS:

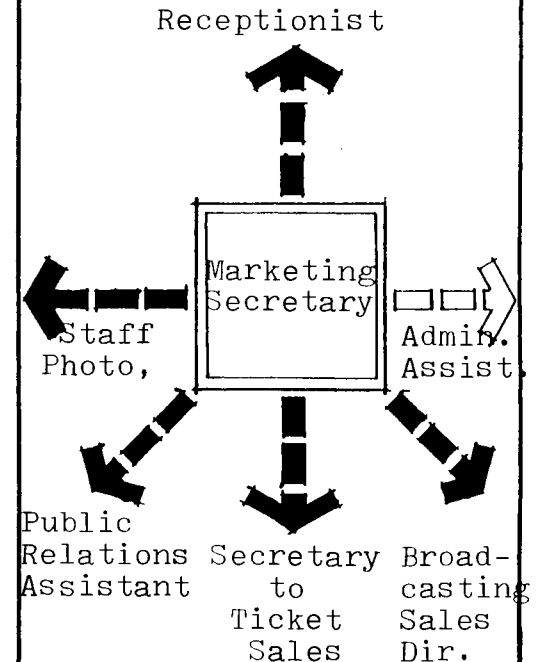

USER: Franchise Office, Basketball

FUNCTION/ACTIVITY:

Director of all player relations and personell activities for the organization.

Director of Player Personell

AREA: 150 s.f.

HEIGHT: 8'-0"

SPECIAL CONDITIONS:

FINISHES

FLOOR: carpet
WALLS: gypsum board
CEILING: 2x4 acoustical lay-in tile

SYSTEMS

LIGHTING: general and task
PLUMBING: none
HVAC: VAV with perimeter heating

EQUIPMENT/FURNITURE:

desk with chair, two side chairs, filing cabinet and bookshelves.

RELATIONSHIPS:

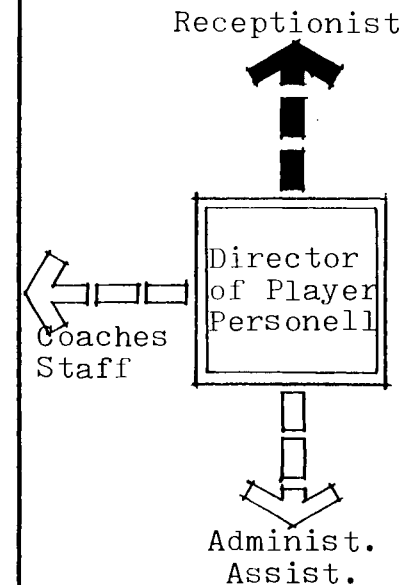

USER: Franchise Office, Basketball

FUNCTION/ACTIVITY:

Director of the accounting department and financial records.

Accounting Department Head

AREA: 250 s.f.

HEIGHT: 8'-0"

SPECIAL CONDITIONS:

FINISHES

FLOOR: carpet
WALLS: gypsum board
CEILING: 2x4 acoustical lay-in tile

SYSTEMS

LIGHTING: general and task
PLUMBING: none
HVAC: VAV with perimeter heating

EQUIPMENT/FURNITURE:

desk with chair, two side chairs, credenza, upright filing and storage cabinets, bookshelves.

RELATIONSHIPS:

Receptionist



Accounting Assistant

USER: Franchise Office, Basketball

FUNCTION/ACTIVITY:

Assistant to and share responsibilities with the Accounting Department Head.

Accounting Department Assistant

AREA: 175 s.f.

HEIGHT: 8'-0"

SPECIAL CONDITIONS:

FINISHES

FLOOR: carpet

WALLS: gypsum board

CEILING: 2x4 acoustical lay-in tile

SYSTEMS

LIGHTING: general and task

PLUMBING: none

HVAC: VAV with perimeter heating

EQUIPMENT/FURNITURE:

desk with chair, filing storage, two side chairs, bookshelves.

RELATIONSHIPS:

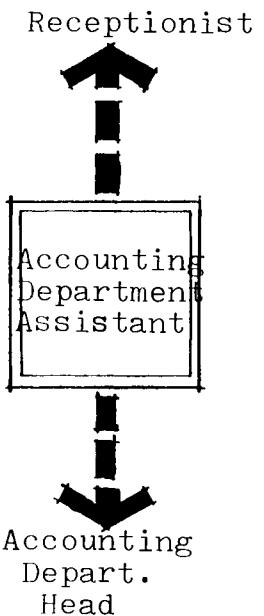

USER: Franchise Office, Basketball

FUNCTION/ACTIVITY:
Director and overseer of all ticket functions including purchases, and distribution of tickets.

Ticket Manager

AREA: 200 s.f.

HEIGHT: 8'-0"

SPECIAL CONDITIONS:

FINISHES

FLOOR: carpet
WALLS: gypsum board
CEILING: 2x4 acoustical lay-in tile

SYSTEMS

LIGHTING: general and task
PLUMBING: none
HVAC: VAV with perimeter heating

EQUIPMENT/FURNITURE:

desk with chair, two side chairs, upright storage and bookshelves

RELATIONSHIPS:

Secretary to Ticket Sales

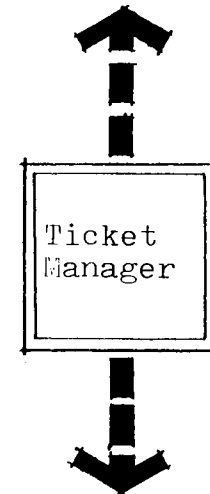

Ticket Clerks

USER: Franchise Office, Basketball

FUNCTION/ACTIVITY:

Actual selling and distribution of tickets
one sells tickets by phone, one clerk
arranges purchases and group sales and
inputs on computer, and one window sales

Ticket Clerks

AREA: 500 s.f.

HEIGHT: 8'-0"

SPECIAL CONDITIONS:

open office type planning

FINISHES

FLOOR: carpet

WALLS: gypsum board

CEILING: 2x4 acoustical lay-in tile

SYSTEMS

LIGHTING: general and task

PLUMBING: none

HVAC: VAV with perimeter heating

EQUIPMENT/FURNITURE:

desk and chairs, computer terminal area,
storage cabinets, bookshelves and side
chairs.

RELATIONSHIPS:

Secretary to
Ticket Sales

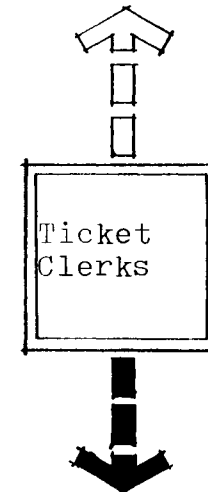

Ticket Manager

USER: Franchise Office, Basketball

FUNCTION/ACTIVITY:

Secretarial and clerical duties for the ticket sales department.

Secretary for Ticket Sales

AREA: 175 s.f.

HEIGHT: 8'-0"

SPECIAL CONDITIONS:

FINISHES

FLOOR: carpet

WALLS: gypsum board

CEILING: 2x4 acoustical lay-in tile

SYSTEMS

LIGHTING: general and task

PLUMBING: none

HVAC: VAV with perimeter heating

EQUIPMENT/FURNITURE:

desk with chair, typing wing, filing and storage cabinets, and two side chairs.

RELATIONSHIPS:

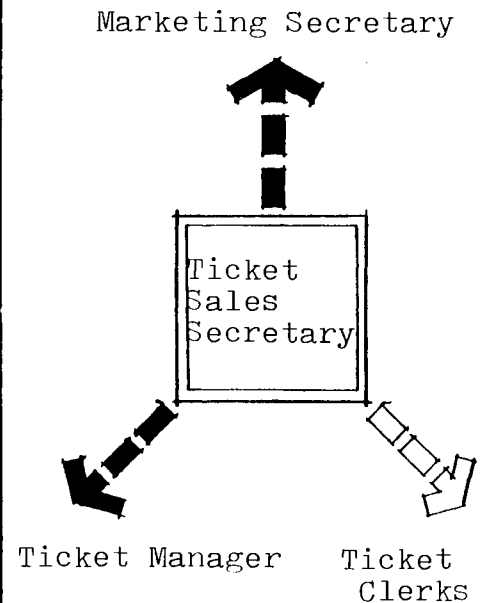

USER: Franchise Office, Basketball

FUNCTION/ACTIVITY:

Photographs of events for promotional and organization purposes for the organization itself.

Staff Photographer

AREA: 150 s.f.

HEIGHT: 8'-0"

SPECIAL CONDITIONS:

FINISHES

FLOOR: carpet

WALLS: gypsum board

CEILING: 2x4 acoustical lay-in tile

SYSTEMS

LIGHTING: general and task

PLUMBING: none

HVAC: VAV with perimeter heating

EQUIPMENT/FURNITURE:

desk with chair, shelves and filing storage and side chair.

RELATIONSHIPS:

Marketing Secretary

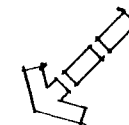
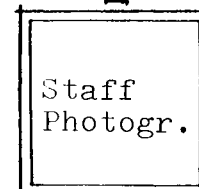

Public Relations Assistant



Darkroom

USER: Franchise Office, Basketball

FUNCTION/ACTIVITY:

Development of film for the staff
photographer

Photographers
Darkroom

AREA: 50 s.f.

HEIGHT: 8'-0"

SPECIAL CONDITIONS:

FINISHES

FLOOR: va tile

WALLS: gypsum board painted black

CEILING: 2x4 acoustiaal tile painted black

SYSTEMS

LIGHTING: general and special for darkroom

PLUMBING: water facet and sink, as required

HVAC: VAV with perimeter heating

EQUIPMENT/FURNITURE:

tables and developers equipment

RELATIONSHIPS:

Staff Photographer



USER: Franchise Office, Basketball

FUNCTION/ACTIVITY:

Storage of general office equipment and materials for the office.

Storage room

AREA: 200 s.f.

HEIGHT: 8'-0"

SPECIAL CONDITIONS:

FINISHES

FLOOR: va tile

WALLS: gypsum board

CEILING: 2x4 acousticle lay-in tile

SYSTEMS

LIGHTING: general

PLUMBING: none

HVAC: VAV with perimeter heating

EQUIPMENT/FURNITURE:

shelves and cabinets for storage

RELATIONSHIPS:

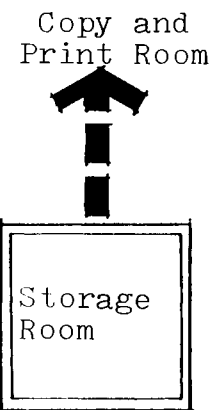

USER: Franchise Office, Basketball

FUNCTION/ACTIVITY:

A workroom for copying and printing with binding for the basketball organization

Copy and Print Room

AREA: 350 s.f.

HEIGHT: 8'-0"

SPECIAL CONDITIONS:

FINISHES

FLOOR: va tile
WALLS: gypsum board
CEILING: 2x4 acoustical lay-in tile

SYSTEMS

LIGHTING: general
PLUMBING: sink
HVAC: VAV with perimeter heating, ventilation

EQUIPMENT/FURNITURE:

shelves and cabinets for storage, xerox machine, and binding equipment

RELATIONSHIPS:

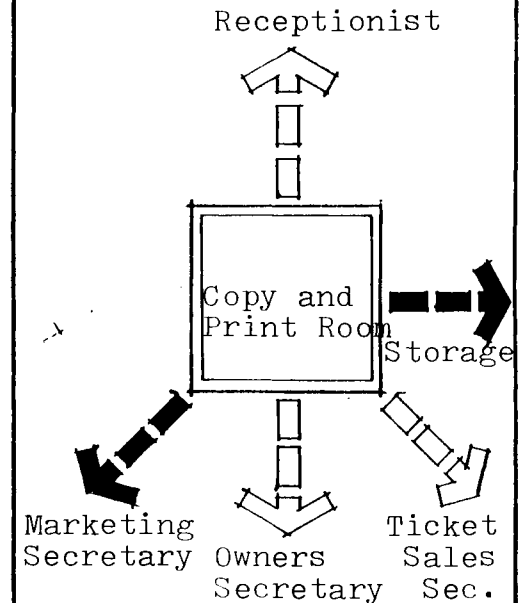

USER: Franchise Office, Basketball

FUNCTION/ACTIVITY:

Coach of the Basketball club for the organization

Coaches Office

AREA: 350 s.f.

HEIGHT: 8'-0"

SPECIAL CONDITIONS:

FINISHES

FLOOR: carpet

WALLS: gypsum board

CEILING: 2x4 acoustical lay-in tile

SYSTEMS

LIGHTING: general and task

PLUMBING: none

HVAC: VAV with perimeter heating

EQUIPMENT/FURNITURE:

desk with chair, two side chairs, shelves and couch

RELATIONSHIPS:

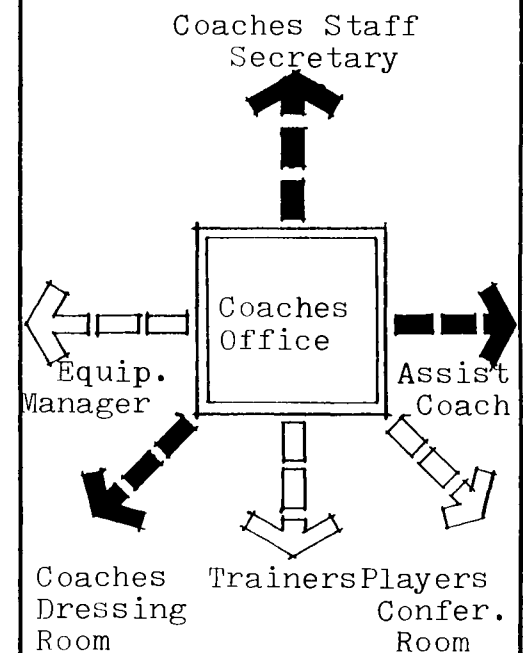

USER: Franchise Office, Basketball

FUNCTION/ACTIVITY:
Assist with the duties of the Head Coach

Assistant Coach Office

AREA: 250 s.f.

HEIGHT: 8'-0"

SPECIAL CONDITIONS:

FINISHES
FLOOR: carpet
WALLS: gypsum board
CEILING: 2x4 acoustical lay-in tile

SYSTEMS
LIGHTING: general and task
PLUMBING: none
HVAC: VAV with perimeter heating

EQUIPMENT/FURNITURE:
desk with chair, two side chairs,
bookshelves and chouch

RELATIONSHIPS:

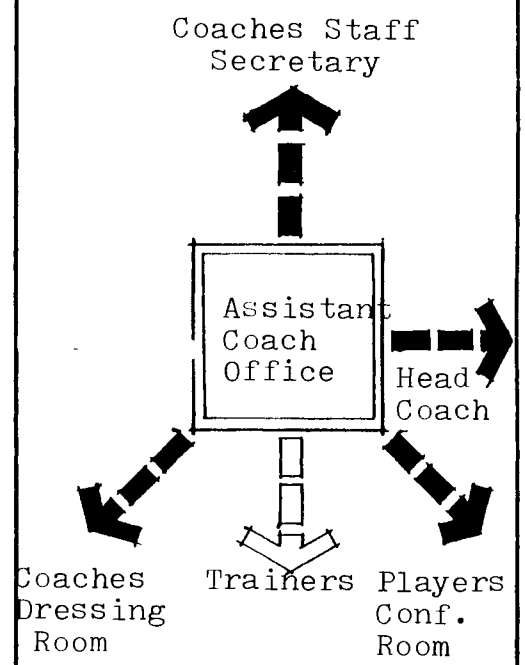

USER: Franchise Office, Basketball

FUNCTION/ACTIVITY:

Health and physical condition of the players of the organization and taping prior to games.

Trainers Office

AREA: 225 s.f.

HEIGHT: 8'-0"

SPECIAL CONDITIONS:

FINISHES

FLOOR: carpet

WALLS: gypsum board

CEILING: 2x4 acoustical lay-in tile

SYSTEMS

LIGHTING: general and task

PLUMBING: none

HVAC: VAV with perimeter heating

EQUIPMENT/FURNITURE:

desk with chair, two side chairs, storage cabinet with bookshelves.

RELATIONSHIPS:

Coaches Staff
Secretary

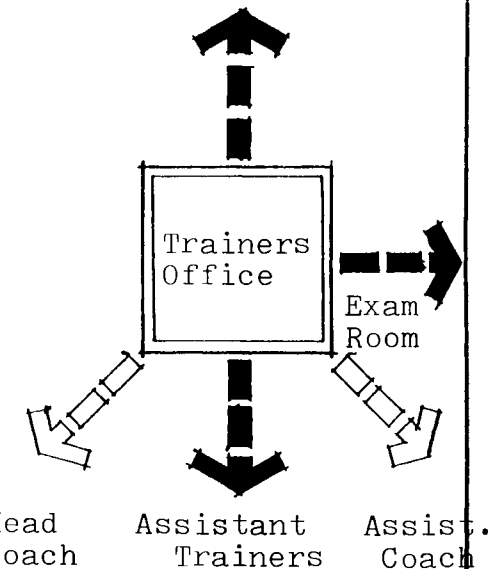

USER: Franchise Office, Basketball

FUNCTION/ACTIVITY:

Assist with the duties and responsibility of the Head Trainer, wrapping and taping before game and assist with minor injuries.

Assistant Trainers
Office

AREA: 200 s.f.

HEIGHT: 8'-0"

SPECIAL CONDITIONS:

FINISHES

FLOOR: carpet

WALLS: gypsum board

CEILING: 2x4 acoustical lay-in tile

SYSTEMS

LIGHTING: general and task

PLUMBING: none

HVAC: VAV with perimeter heating

EQUIPMENT/FURNITURE:

desk with chair, one side chair, storage cabinet with bookshelves.

RELATIONSHIPS:



USER: Franchise Office, Basketball

FUNCTION/ACTIVITY:

Responsible for the storage and purchase of team equipment and materials.

Equipment Manager

AREA: 150 s.f.

HEIGHT: 8'-0"

SPECIAL CONDITIONS:

FINISHES

FLOOR: carpet
WALLS: gypsum board
CEILING: 2x4 acoustical lay-in tile

SYSTEMS

LIGHTING: general and task
PLUMBING: none
HVAC: VAV with perimeter heating

EQUIPMENT/FURNITURE:

desk with chair, side chair, bookshelves, and storage locker

RELATIONSHIPS:

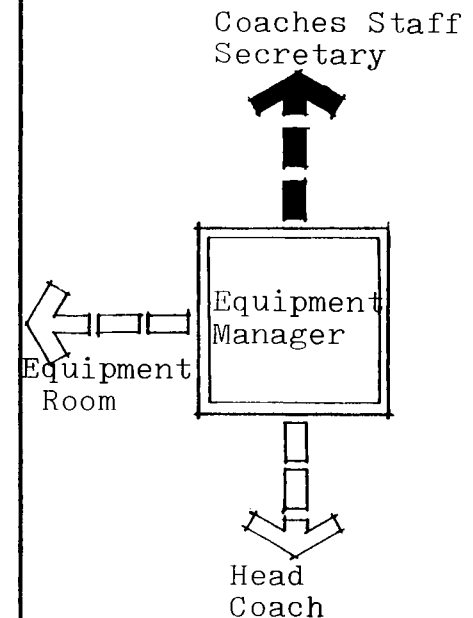

USER: Franchise Office, Basketball

FUNCTION/ACTIVITY:

Storage and organization room for the team equipment

Equipment Storage Room

AREA: 300 s.f.

HEIGHT: 8'-0"

SPECIAL CONDITIONS:

must be easily accessible both by the players and the equipment manager with trainers.

FINISHES

FLOOR: va tile
WALLS: gypsum board
CEILING: 2x4 acoustical lay-in tile

SYSTEMS

LIGHTING: general
PLUMBING: none
HVAC: VAV with perimeter heating

EQUIPMENT/FURNITURE:

shelves for the storage of equipment and a counter for dispensing of equipment

RELATIONSHIPS:

Equipment Manager

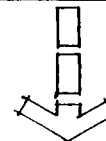
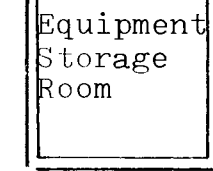
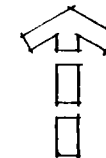

Players Dressing Area

USER: Franchise Office, Basketball

FUNCTION/ACTIVITY:

Area for the trainers to use for taping knees, ankles, and pre-game physical checks.

Trainers Taping Room

AREA: 400 s.f.

HEIGHT: 8'-0"

SPECIAL CONDITIONS:

FINISHES

FLOOR: va tile

WALLS: gypsum board

CEILING: 2x4 acoustical lay-in tile

SYSTEMS

LIGHTING: general and task

PLUMBING: as required

HVAC: VAV with perimeter heating

EQUIPMENT/FURNITURE:

taping tables, cabinets with counters, and equipment storage area

RELATIONSHIPS:

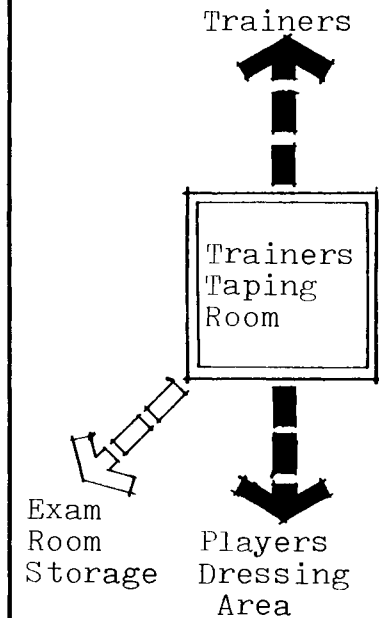

USER: Franchise Office, Basketball

FUNCTION/ACTIVITY:
Storage for equipment and materials
for the trainers

Trainers Exam Room
Storage

AREA: 100 s.f.

HEIGHT: 9'-0"

SPECIAL CONDITIONS:

FINISHES

FLOOR: va tile
WALLS: gypsum board
CEILING: 2x4 acoustical lay-in tile

SYSTEMS

LIGHTING: general
PLUMBING: none
H V A C: VAV with perimeter heating

EQUIPMENT/FURNITURE:
shelves for storage.

RELATIONSHIPS:

Trainers Exam Rm.



USER: Franchise Office, Basketball

FUNCTION/ACTIVITY:

Dressing and changing area for the basketball coach and his assistant

Coaches
Dressing Room

AREA: 200 s.f.

HEIGHT: 8'-0"

SPECIAL CONDITIONS:

FINISHES

FLOOR: carpet
WALLS: gypsum board
CEILING: 2x4 acoustical lay-in tile

SYSTEMS

LIGHTING: general
PLUMBING: sink, shower, and toilet
HVAC: VAV with perimeter heating

EQUIPMENT/FURNITURE:

locker with seating, couch and two chairs.

RELATIONSHIPS:

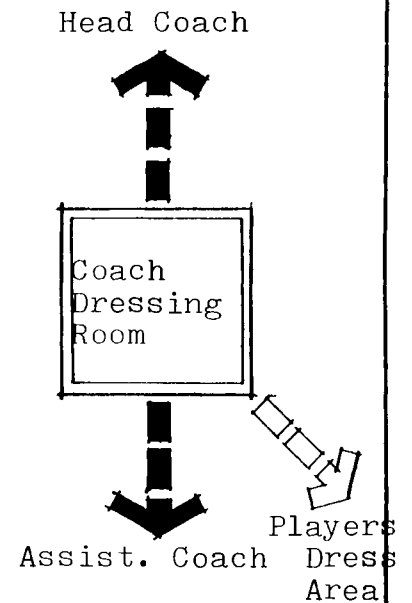

USER: Franchise Office, Basketball

FUNCTION/ACTIVITY:

Dressing area for the home basketball organization to be used for games and practices.

Home Dressing Area

AREA: 1500 s.f.

HEIGHT: 9'-0"

SPECIAL CONDITIONS:

FINISHES

FLOOR: carpet

WALLS: gypsum board

CEILING: 2x4 acoustical lay-in tile

SYSTEMS

LIGHTING: general

PLUMBING: none

HVAC: VAV with perimeter heating

EQUIPMENT/FURNITURE:

lockers with bench type seating for 15-20 persons, chalkboards, open area for meetings at halftime.

RELATIONSHIPS:

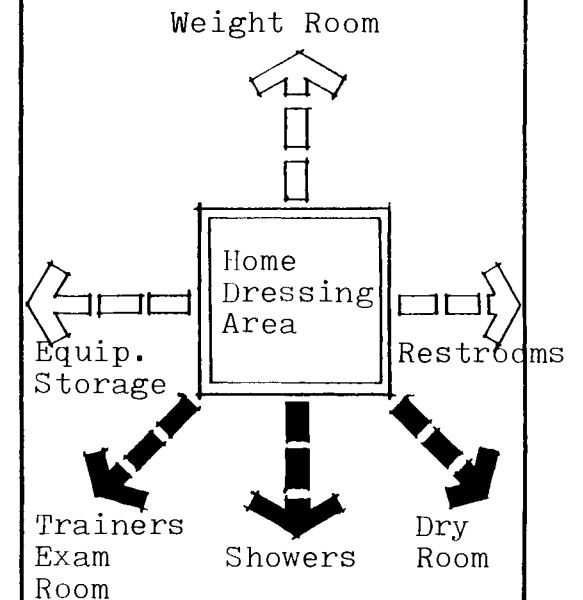

USER: Franchise Office, Basketball

FUNCTION/ACTIVITY:

shower area for players to use after practices and games.

Home Shower area

AREA: 300 s.f.

HEIGHT: 9'-0"

SPECIAL CONDITIONS:

FINISHES

FLOOR: ceramic tile
WALLS: ceramic tile
CEILING: gypsum board

SYSTEMS

LIGHTING: general
PLUMBING: showers heads
HVAC: ventilated

EQUIPMENT/FURNITURE:

shower head arranged in either stalls or open plan

RELATIONSHIPS:



USER: Franchise Office, Basketball

FUNCTION/ACTIVITY:

Drying area for the basketball club after showering.

Dry Room

AREA: 150 s.f.

HEIGHT: 9'-0"

SPECIAL CONDITIONS:

FINISHES

FLOOR: ceramic tile
WALLS: ceramic tile
CEILING: gypsum board

SYSTEMS

LIGHTING: general and task
PLUMBING: sinks
HVAC: VAV with perimeter Heating, ventilation

EQUIPMENT/FURNITURE:

sitting area for drying and hanging towels, with a towel storage area, hair dryers, sinks, mirrors, shelf under mirrors.

RELATIONSHIPS:



USER: Franchise Office, Basketball

FUNCTION/ACTIVITY:

restrooms for the players use located near the dressing and shower rooms

Rest Rooms

AREA: 150 s.f. + 100 s.f. Handicap

HEIGHT: 9'-0"

SPECIAL CONDITIONS:

FINISHES

FLOOR: ceramic tile

WALLS: ceramic tile

CEILING: gypsum board

SYSTEMS

LIGHTING: general

PLUMBING: toilets

HVAC: VAV with perimeter heating, ventilation

EQUIPMENT/FURNITURE:

toilets with partitions.

RELATIONSHIPS:

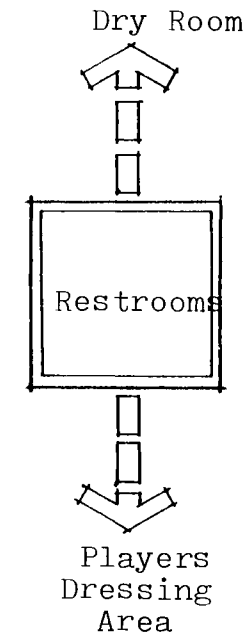

USER: Franchise Office, Basketball

FUNCTION/ACTIVITY:

dressng area for the visiting team for games and scrimmages

Visitors Dressing Area

AREA: 1000 s.f.

HEIGHT: 9'-0"

SPECIAL CONDITIONS:

FINISHES

FLOOR: carpet
WALLS: gypsum board
CEILING: 2x4 acoustical lay-in tile

SYSTEMS

LIGHTING: general
PLUMBING: none
HVAC: VAV with perimeter heating

EQUIPMENT/FURNITURE:

lockers with bench type seating, for 15-20 persons, chalkboard with viewing or meeting area.

RELATIONSHIPS:

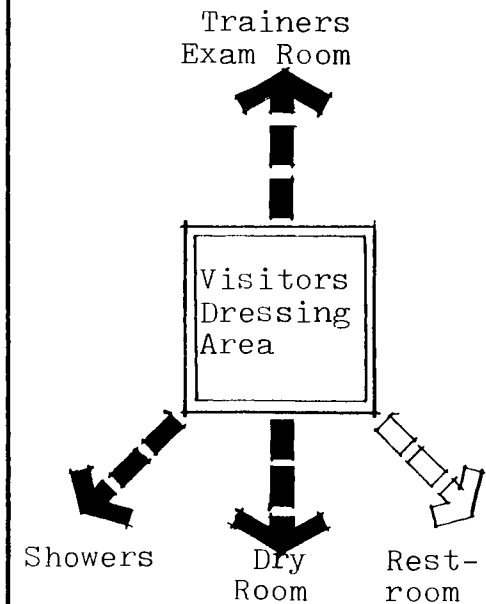

USER: Franchise Office, Basketball

FUNCTION/ACTIVITY:
showering and drying area for the visiting team after events or scrimmages.

Visitors shower and
Dry room

AREA: 300 s.f.

HEIGHT: 9'-0"

SPECIAL CONDITIONS:

FINISHES

FLOOR: ceramic tile

WALLS: ceramic tile

CEILING: gypsum board

SYSTEMS

LIGHTING: general

PLUMBING: showers, sinks,

HVAC: VAV with perimeter heating, ventilation

EQUIPMENT/FURNITURE:

benches, sinks, mirrors, showers, towel
hangars, and storage area for towels.

RELATIONSHIPS:



USER: Franchise Office, Basketball

FUNCTION/ACTIVITY:

rest room for the use of the visiting team during activities or events.

Visitors Rest room

AREA: 150 s.f.

HEIGHT: 9'-0"

SPECIAL CONDITIONS:

FINISHES

FLOOR: ceramic tile

WALLS: ceramic tile

CEILING: gypsum board

SYSTEMS

LIGHTING: general

PLUMBING: toilets

HVAC: VAV with perimeter heating

EQUIPMENT/FURNITURE:

water closets with dividers

RELATIONSHIPS:

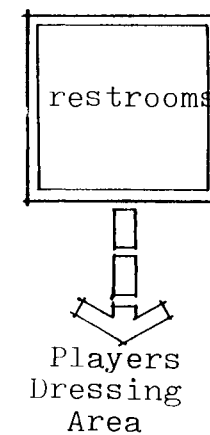

USER: Franchise Office, Basketball

FUNCTION/ACTIVITY:

used by the visiting team trainers for the taping of players and minor medical and physicals prior to games.

Visitors Taping Room

AREA: 400 s.f.

HEIGHT: 9'-0"

SPECIAL CONDITIONS:

FINISHES

FLOOR: carpet

WALLS: gypsum board

CEILING: 2x4 acoustical lay-in tile

SYSTEMS

LIGHTING: general and task

PLUMBING: as required

HVAC: VAV with perimeter heating, ventilation

EQUIPMENT/FURNITURE:

as required, taping tables, cabinets for storage, counters, sinks

RELATIONSHIPS:

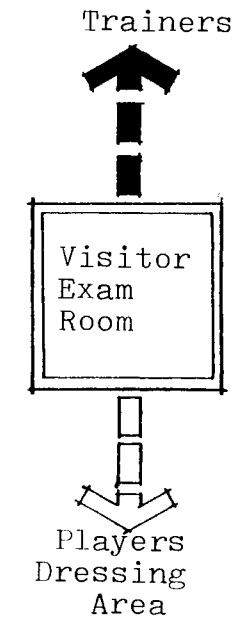

USER: Franchise Office, Basketball

FUNCTION/ACTIVITY:

hold meetings for recruiting, trading,
business of the franchise, for the
Board of Directors,

Conference Room

AREA: 300 s.f.

HEIGHT: 8'-0"

SPECIAL CONDITIONS:

FINISHES

FLOOR: carpet
WALLS: gypsum board with vinyl covering
CEILING: 2x4 acoustical lay-in tile

SYSTEMS

LIGHTING: general and task
PLUMBING: sink with wet bar
HVAC: VAV with perimeter heating

EQUIPMENT/FURNITURE:

conference table for fifteen, refreshment
bar, and visual capabilities.

RELATIONSHIPS:

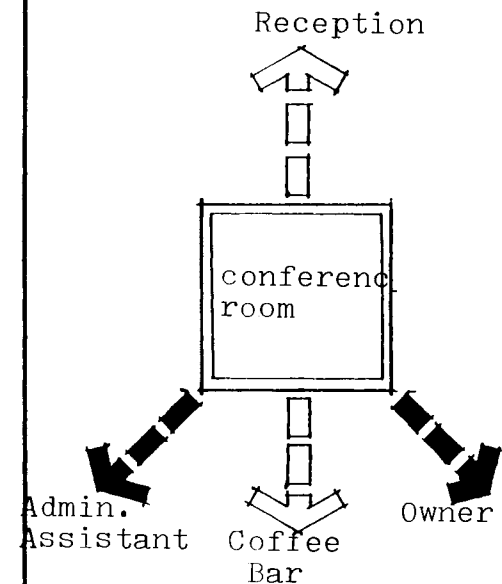

USER: Franchise Office, Basketball

FUNCTION/ACTIVITY:

area for refreshments and coffee for the staff and the organization

Coffee Bar

AREA: 50 s.f.

HEIGHT: 8'-0"

SPECIAL CONDITIONS:

FINISHES

FLOOR: carpet

WALLS: gypsum board

CEILING: 2x4 acoustical lay-in tile

SYSTEMS

LIGHTING: general

PLUMBING: sink

HVAC: VAV with perimeter heating

EQUIPMENT/FURNITURE:

cabinets for storage, under counter refrigerator, counter top.

RELATIONSHIPS:

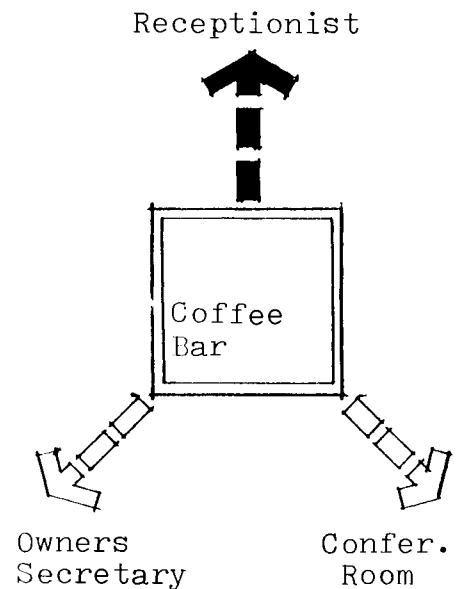

USER: Franchise Office, Basketball

FUNCTION/ACTIVITY:

Room for the players and coaches for viewing films before and after games for the review by coaches and pre-game scouting

Players Conference Room

AREA: 375 s.f.

HEIGHT: 9'-0"

SPECIAL CONDITIONS:

Capable of showing films

FINISHES

FLOOR: carpet or tile

WALLS: gypsum board

CEILING: 2x4 acoustical lay-in tile

SYSTEMS

LIGHTING: general

PLUMBING: none

HVAC: VAV with perimeter heating

EQUIPMENT/FURNITURE:

Seating for 25 persons, slide projector and reel to reel movie projector

RELATIONSHIPS:

Coaching Staff



Players

FRANCHISE OFFICE, FOOTBALL

102

MULTI-USE SPORTS FACILITY, OKLAHOMA CITY

USER: Franchise Office, Football

FUNCTION/ACTIVITY:

Public and people first introduction to the franchise, shall be pleasing and accomodated while waiting to meet respective persons.

Waiting and Reception area

AREA: 300 s.f.

HEIGHT: 8'-0"

SPECIAL CONDITIONS:

FINISHES

FLOOR: carpet

WALLS: gypsum board with graphics

CEILING: 2x4 acoustical lay-in tile

SYSTEMS

LIGHTING: general and downlighting

PLUMBING: none

H V A C: VAV with perimeter heating

EQUIPMENT/FURNITURE:

seating for ten persons with end table and graphics.

RELATIONSHIPS:

Public Entry

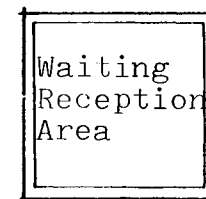

Receptionist

USER: Franchise Office, Football

FUNCTION/ACTIVITY:

Receives guests and acts as a control point to the offices of the Franchise, light secretarial work and receives phone calls.

Receptionist

AREA: 200 s.f.

HEIGHT: 8'-0"

SPECIAL CONDITIONS:

FINISHES

FLOOR: carpet

WALLS: gypsum board

CEILING: 2x4 acoustical lay-in tile

SYSTEMS

LIGHTING: general and task

PLUMBING: none

HVAC: VAV with perimeter heating

EQUIPMENT/FURNITURE:

desk with chair, credenza, typing wing, telephone switchboard table.

RELATIONSHIPS:

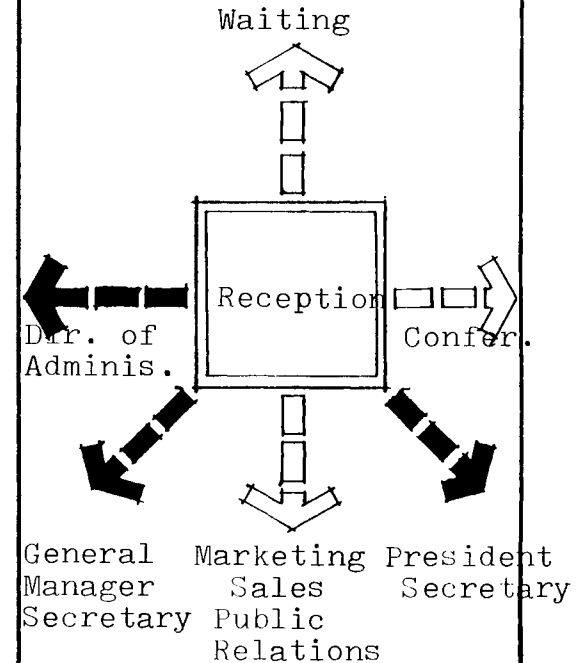

USER: Franchise Office, Football

FUNCTION/ACTIVITY:

Refreshment and coffee for the organization and personell in the organization

Coffee and Refreshment Bar

AREA: 50 s.f.

HEIGHT: 8'-0"

SPECIAL CONDITIONS:

FINISHES

FLOOR: carpet
WALLS: gypsum board
CEILING: 2x4 acoustical lay-in tile

SYSTEMS

LIGHTING: general
PLUMBING: sink
HVAC: VAV with perimeter heating

EQUIPMENT/FURNITURE:

shelves and cabinets for storage of refreshments, undercounter refrigerator, counter top.sink,

RELATIONSHIPS:

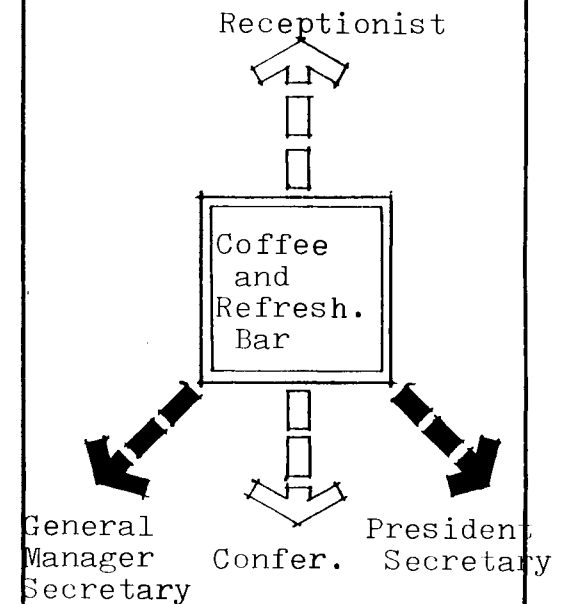

USER: Franchise Office, Football

FUNCTION/ACTIVITY:

Conference area for the administrative personell and business activities.

Conference Room

AREA: 225 s.f. seating for 15 persons

HEIGHT: 9'-0"

SPECIAL CONDITIONS:

FINISHES

FLOOR: carpet
WALLS: gypsum board
CEILING: 2x4 acoustical lay-in tile

SYSTEMS

LIGHTING: general and task
PLUMBING: none
HVAC: VAV with perimeter heating

EQUIPMENT/FURNITURE:

conference table and chairs for fifeteen
refreshment bar and film viewing.

RELATIONSHIPS:

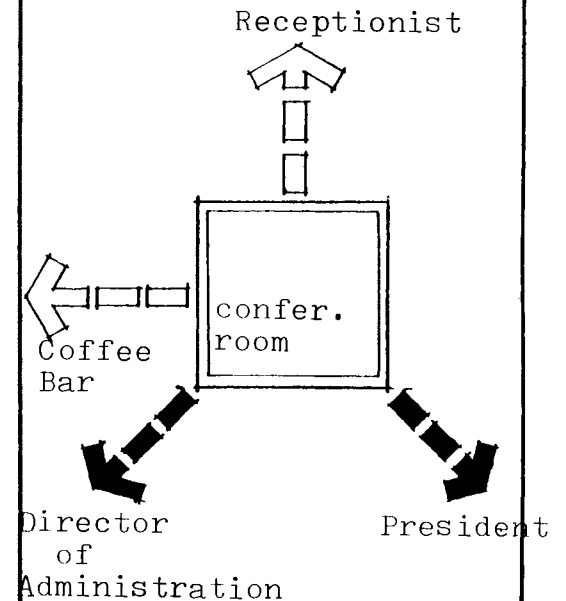

USER: Franchise Office, Football

FUNCTION/ACTIVITY:

conference area for the organization as a whole for employees and organizational meetings.

Conference Room

AREA: seating area for 30 persons, 450 s.f.

HEIGHT: 9'-0"

SPECIAL CONDITIONS:

FINISHES

FLOOR: carpet
WALLS: gypsum board
CEILING: 2x4 acoustical lay-in tile

SYSTEMS

LIGHTING: general and task
PLUMBING: sink
HVAC: VAV with perimeter heating

EQUIPMENT/FURNITURE:

conference table and chairs for thirty persons with visual capabilities.

RELATIONSHIPS:

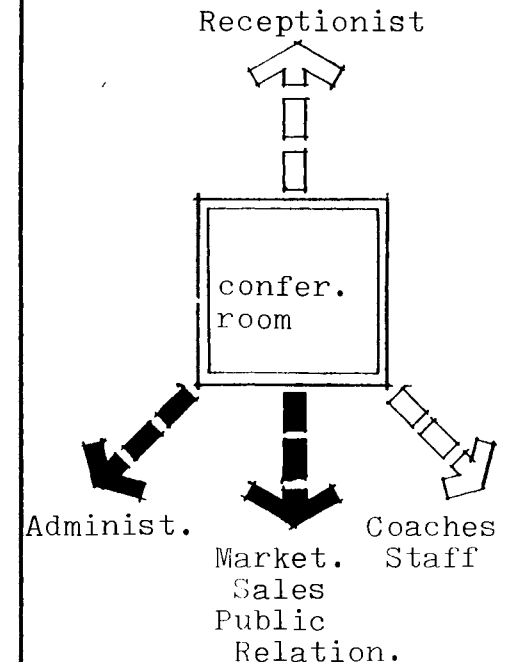

USER: Franchise Office, Football

FUNCTION/ACTIVITY:

Conference area for the players and coaches for viewing pre-game scouting films and team meetings.

Conference Room

AREA: 1000 s.f. meeting for 75 persons.

HEIGHT: 9'-0"

SPECIAL CONDITIONS:

FINISHES

FLOOR: carpet

WALLS: gypsum board

CEILING: 2x4 acoustical lay-in tile

SYSTEMS

LIGHTING: general and task

PLUMBING: none

HVAC: VAV with perimeter heating

EQUIPMENT/FURNITURE:

chairs for 75 with viewing capabilities and slide projector cabinet.

RELATIONSHIPS:

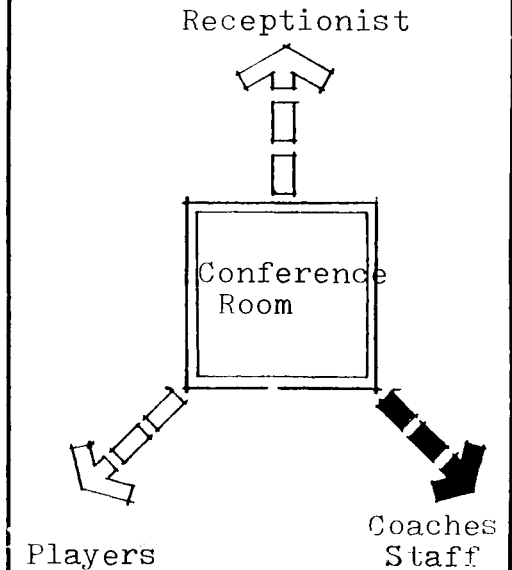

USER: Franchise Office, Football

FUNCTION/ACTIVITY:

Arrange financial backing for the organization and makes management, financial, and personell decisions.

Presidents Office,

AREA: 450 s.f.

HEIGHT: 8'-0"

SPECIAL CONDITIONS:
restroom facilities.

FINISHES

FLOOR: carpet
WALLS: gypsum board vinyl covered
CEILING: 2x4 acoustical lay-in tile

SYSTEMS

LIGHTING: general and task
PLUMBING: none
HVAC: VAV with perimeter heating

EQUIPMENT/FURNITURE:

Executive desk and chair, credenza, conference table for four, couch, bookshelves

RELATIONSHIPS:

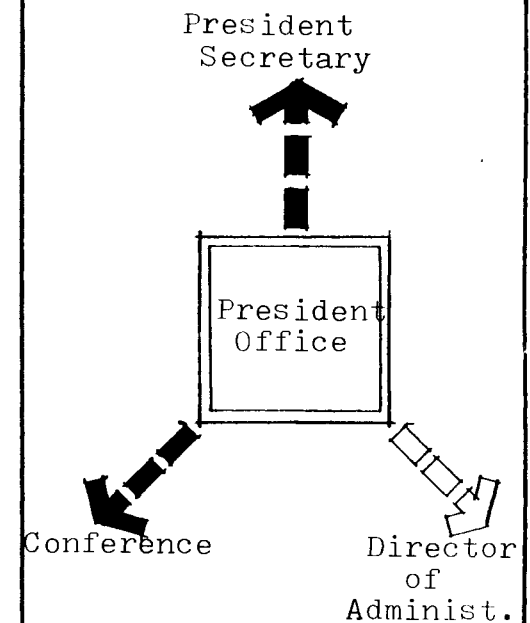

USER: Franchise Office, Football

FUNCTION/ACTIVITY:

Secretary and clerical duties associated with the President of the Office and receptionist to the Office.

Presidents Secretary

AREA: 200 s.f.

HEIGHT: 8'-0"

SPECIAL CONDITIONS:

FINISHES

FLOOR: carpet
WALLS: gypsum board
CEILING: 2x4 acoustical lay-in tile

SYSTEMS

LIGHTING: general and task
PLUMBING: none
HVAC: VAV with perimeter heating

EQUIPMENT/FURNITURE:

desk with typing wind and chair, file storage, seating for four, and tables.

RELATIONSHIPS:

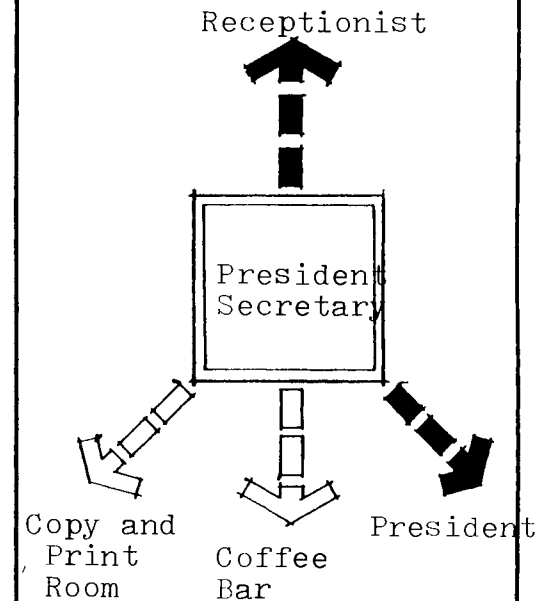

USER: Franchise Office, Football

FUNCTION/ACTIVITY:

Director of all administrative activities, promotes contracts, advertisements, and game day programs.

Director of Administration

AREA: 300 s.f.

HEIGHT: 8'-0"

SPECIAL CONDITIONS:

FINISHES

FLOOR: carpet
WALLS: gypsum board
CEILING: 2x4 acoustical lay-in tile

SYSTEMS

LIGHTING: general and task
PLUMBING: none
HVAC: VAV with perimeter heating

EQUIPMENT/FURNITURE:

desk with chair, side chair for two, conference table for four, credenza, couch and bookshelves.

RELATIONSHIPS:

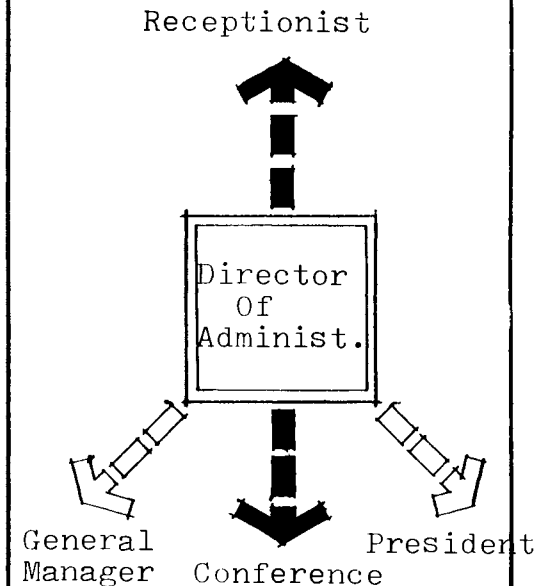

USER: Franchise Office, Football

FUNCTION/ACTIVITY:

Handles all releases to the media,
media coverage of games, contracts,
and relations with the media.

Media Relations
Director

AREA: 200 s.f.

HEIGHT: 8'-0"

SPECIAL CONDITIONS:

FINISHES

FLOOR: carpet

WALLS: gypsum board

CEILING: 2x4 acoustical lay-in tile

SYSTEMS

LIGHTING: general and task

PLUMBING: none

HVAC: VAV with perimeter heating

EQUIPMENT/FURNITURE:

desk with chair, two side chairs, credenza,
couch and bookshelves.

RELATIONSHIPS:

Secretary to
Public Relations



Staff
Photographer



Marketing
and
Advertis.
Media
Assistant

USER: Franchise Office, Football

FUNCTION/ACTIVITY:

Assistant to and duties of the Director of Administration and the Media Relations Director.

Marketing and Advertising Media Assistant

AREA: 150 s.f.

HEIGHT: 8'-0"

SPECIAL CONDITIONS:

FINISHES

FLOOR: carpet

WALLS: gypsum board

CEILING: 2x4 acoustical lay-in tile

SYSTEMS

LIGHTING: general and task

PLUMBING: none

HVAC: VAV with perimeter heating

EQUIPMENT/FURNITURE:

desk with chair, two side chairs, credenza and bookshelves.

RELATIONSHIPS:

Secretary to Public Relations

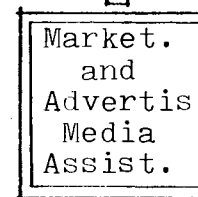
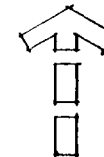

Media Relations Director

USER: Franchise Office, Football

FUNCTION/ACTIVITY:

Secretarial and clerical work related to the Public Relations Department.

Secretary to
Public Relations

AREA: 350 s.f. for two secretaries

HEIGHT: 8'-0"

SPECIAL CONDITIONS:
open office typlan

FINISHES

FLOOR: carpet
WALLS: gypsum board
CEILING: 2x4 acoustical lay-in tile

SYSTEMS

LIGHTING: general and task
PLUMBING: none
HVAC: VAV with perimeter heating

EQUIPMENT/FURNITURE:

two secretarial stations of desk and typing wing with chair, seating for four, upright filing storage cabinets, and bookshelves.

RELATIONSHIPS:

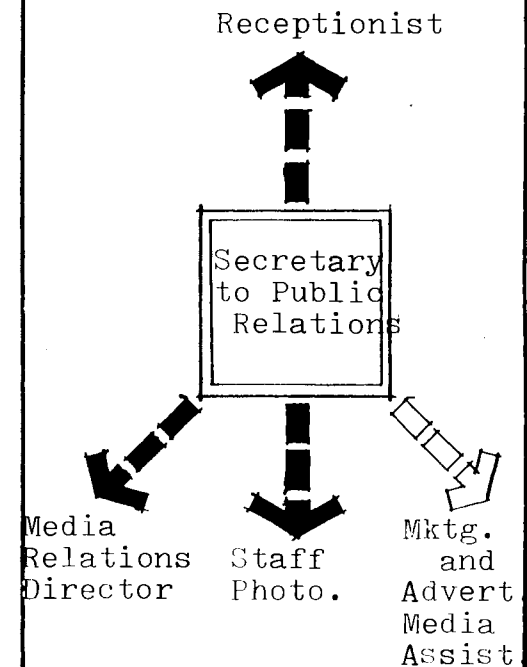

USER: Franchise Office, Football

FUNCTION/ACTIVITY:

Oversees the team and team activities with duties of recruiting and trading practices.

General Manager

AREA: 300 s.f.

HEIGHT: 8'-0"

SPECIAL CONDITIONS:

FINISHES

FLOOR: carpet

WALLS: gypsum board

CEILING: 2x4 acoustical lay-in tile

SYSTEMS

LIGHTING: general and task

PLUMBING: none

HVAC: VAV with perimeter heating

EQUIPMENT/FURNITURE:

executive desk with chair, credenza, two side chairs, conference table for two, and bookshelves.

RELATIONSHIPS:

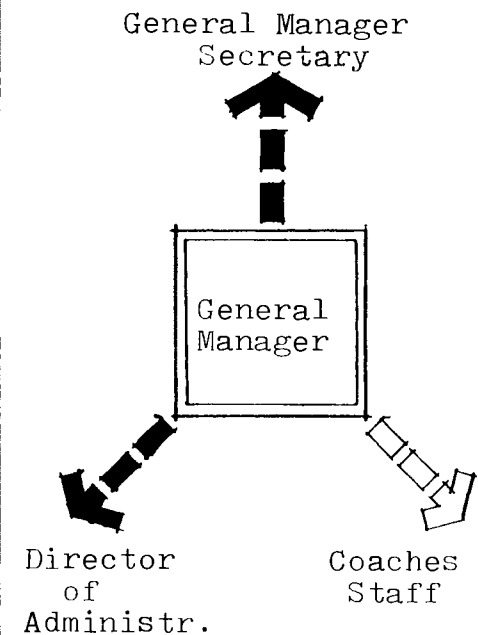

USER: Franchise Office, Football

FUNCTION/ACTIVITY:

secretarial and clerical duties related to the general manager, also receptionist to the general manager.

General Managers
Secretary

AREA: 200 s.f.

HEIGHT: 8'-0"

SPECIAL CONDITIONS:

FINISHES

FLOOR: carpet
WALLS: gypsum board
CEILING: 2x4 acoustical lay-in tile

SYSTEMS

LIGHTING: general and task
PLUMBING: none
HVAC: VAV with perimeter heating

EQUIPMENT/FURNITURE:

desk with chair and typing wing, filing cabinets, seating for four.

RELATIONSHIPS:

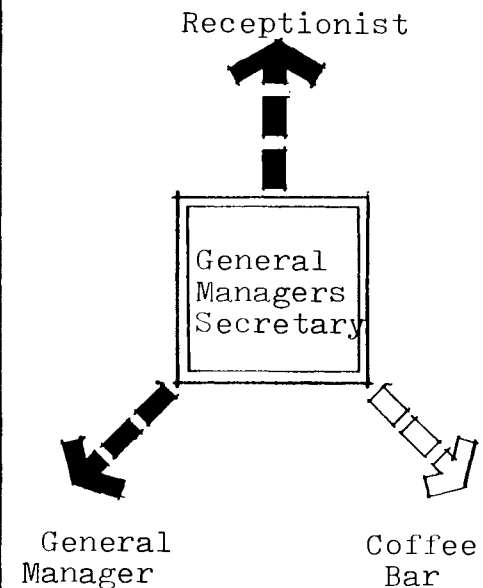

USER: Franchise Office, Football

FUNCTION/ACTIVITY:

Director of all player activities and
player personell relations

Player Personell
Director

AREA: 200 s.f.

HEIGHT: 8'-0"

SPECIAL CONDITIONS:

FINISHES

FLOOR: carpet

WALLS: gypsum board

CEILING: 2x4 acoustical lay-in tile

SYSTEMS

LIGHTING: general and task

PLUMBING: none

H V A C: VAV with perimeter heating

EQUIPMENT/FURNITURE:

desk with chair, two side chairs,
credenza, with bookshelves.

RELATIONSHIPS:

Player Personell
Secretary

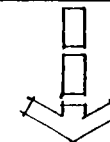
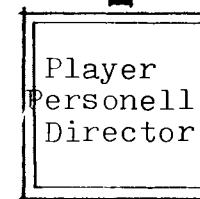

Director
of
Personell
Security

USER: Franchise Office, Football

FUNCTION/ACTIVITY:

Secretarial and clerical duties associated with the player personell director

Secretary to Player
Personell Director

AREA: 150 s.f.

HEIGHT: 8'-0"

SPECIAL CONDITIONS:

FINISHES

FLOOR: carpet
WALLS: gypsum board
CEILING: 2x4 acoustical lay-in tile

SYSTEMS

LIGHTING: general and task
PLUMBING: none
HVAC: VAV with perimeter heating

EQUIPMENT/FURNITURE:

desk with chair, and typing wing, seating for two, filing cabinet and bookshelves.

RELATIONSHIPS:

Receptionist

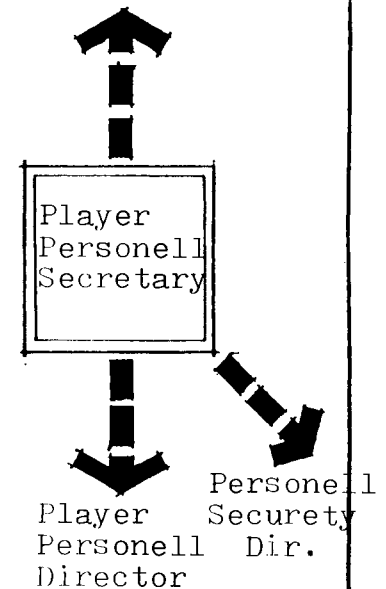

USER: Franchise Office, Football

FUNCTION/ACTIVITY:

Head of the Accounting Department for the Football organization.

Accounting Director

AREA: 250 s.f.

HEIGHT: 8'-0"

SPECIAL CONDITIONS:

FINISHES

FLOOR: carpet

WALLS: gypsum board

CEILING: 2x4 acoustical lay-in tile

SYSTEMS

LIGHTING: general and task

PLUMBING: none

HVAC: VAV with perimeter heating

EQUIPMENT/FURNITURE:

desk with chair, two side chairs, credenza, bookshelves

RELATIONSHIPS:

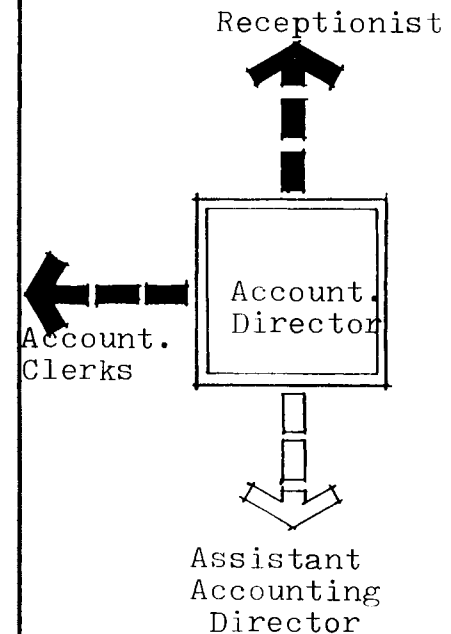

USER: Franchise Office, Football

FUNCTION/ACTIVITY:

Duties of the Accounting Director and oversees all of the accounting clerks.

Assistant Account.
Director

AREA: 200

HEIGHT: 8'-0"

SPECIAL CONDITIONS:

FINISHES

FLOOR: carpet

WALLS: gypsum board

CEILING: 2x4 acoustical lay-in tile

SYSTEMS

LIGHTING: general and task

PLUMBING: none

HVAC: VAV with perimeter heating

EQUIPMENT/FURNITURE:

desk with chair, two side chairs, bookshelves, filing storage

RELATIONSHIPS:

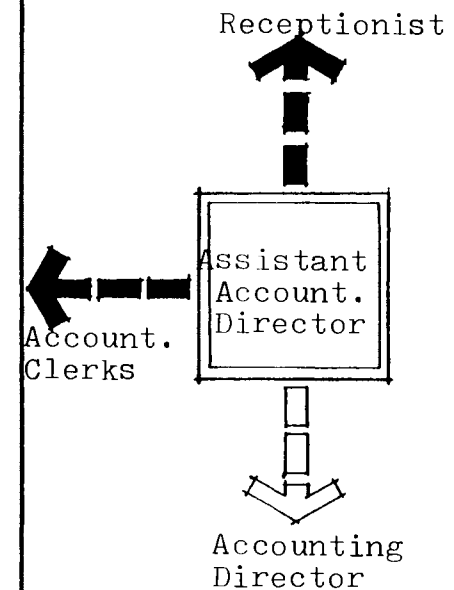

USER: Franchise Office, Football

FUNCTION/ACTIVITY:
Clerical department for the Football organizations accounting.

Accounting Clerks

AREA: 750

HEIGHT: 8'-0"

SPECIAL CONDITIONS:
workstations for five clerks

FINISHES

FLOOR: carpet
WALLS: gypsum board
CEILING: 2x4 acoustical lay-in tile

SYSTEMS

LIGHTING: general and task
PLUMBING: none
HVAC: VAV with perimeter heating

EQUIPMENT/FURNITURE:

desk with chairs, side chairs, storage cabinets, filing cabinets, bookshelves.

RELATIONSHIPS:

Accounting Director

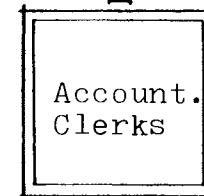

Assistant Accounting Director

USER: Franchise Office, Football

FUNCTION/ACTIVITY:

Arrange for the security of all personell
at away games

Director of
Personell Security

AREA: 150 s.f.

HEIGHT: 8'-0"

SPECIAL CONDITIONS:

FINISHES

FLOOR: carpet

WALLS: gypsum board

CEILING: 2x4 acoustical lay-in tile

SYSTEMS

LIGHTING: general and task

PLUMBING: none

H V A C: VAV with perimeter heating

EQUIPMENT/FURNITURE:

sesk with chair, seating for two,
credenza, with bookshelves.

RELATIONSHIPS:

Player Personell
Secretary

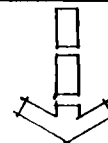
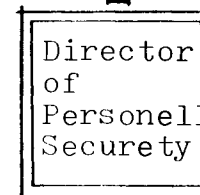

Player
Personell
Director

USER: Franchise Office, Football

FUNCTION/ACTIVITY:

Director and overseer of all ticket functions and purchases, including distribution of tickets, individual and group sales.

Ticket Manager

AREA: 200 s.f.

HEIGHT: 8'-0"

SPECIAL CONDITIONS:

FINISHES

FLOOR: carpet

WALLS: gypsum board

CEILING: 2x4 acoustical lay-in tile

SYSTEMS

LIGHTING: general and task

PLUMBING: none

HVAC: VAV with perimeter heating

EQUIPMENT/FURNITURE:

desk with chair, two side chairs, uprights storage and bookshelves.

RELATIONSHIPS:

Secretary to
Ticket Sales

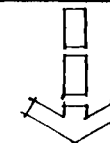

Ticket
Clerks

USER: Franchise Office, Football

FUNCTION/ACTIVITY:

Actual selling and distribution of tickets for the football organization.

Ticket Clerks

AREA: 500 s.f.

HEIGHT: 8'-0"

SPECIAL CONDITIONS:

three clerks, open office, type plan, one sells season tickets and tickets by phone, one arranges purchases and group sales, and one walk in sales.

FINISHES

FLOOR: carpet

WALLS: gypsum board

CEILING: 2x4 acoustical lay-in tile

SYSTEMS

LIGHTING: general and task

PLUMBING: none

HVAC: VAV with perimeter heating

EQUIPMENT/FURNITURE:

desks and chairs, computer terminal area, storage cabinets, bookshelves and side chairs

RELATIONSHIPS:

Secretary to
Ticket Sales

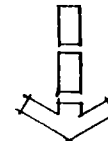
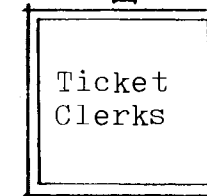

Ticket
Manager

USER: Franchise Office, Football

FUNCTION/ACTIVITY:

Secretarial and clerical duties for the ticket sales department.

Secretary for Ticket Sales

AREA: 175 s.f.

HEIGHT: 8'-0"

SPECIAL CONDITIONS:

FINISHES

FLOOR: carpet

WALLS: gypsum board

CEILING: 2x4 acoustical lay-in tile

SYSTEMS

LIGHTING: general and task

PLUMBING: none

HVAC: VAV with perimeter heating

EQUIPMENT/FURNITURE:

desk with chair, typing wing, filing and storage cabinets, two side chairs.

RELATIONSHIPS:

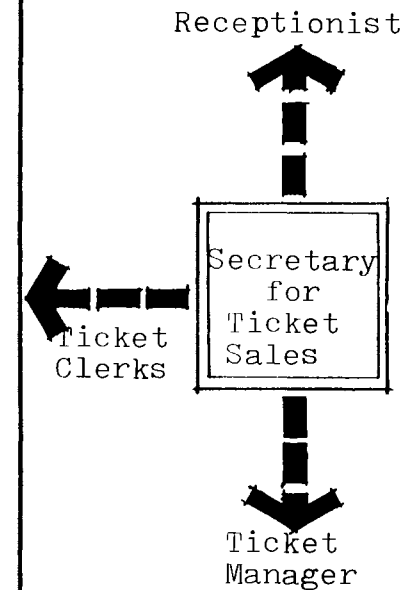

USER: Franchise Office, Football

FUNCTION/ACTIVITY:

storage area for office equipment and materials for the football organization

Storage

AREA: 200 s.f.

HEIGHT: 8'-0"

SPECIAL CONDITIONS:

FINISHES

FLOOR: va tile

WALLS: gypsum board

CEILING: 2x4 acoustical lay-in tile

SYSTEMS

LIGHTING: general and task

PLUMBING: none

HVAC: none

EQUIPMENT/FURNITURE:

shelves and cabinets for storage

RELATIONSHIPS:

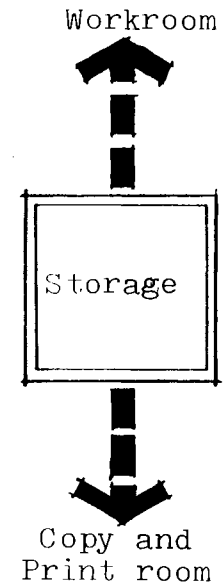

USER: Franchise Office, Football

FUNCTION/ACTIVITY:

Used for the copying and printing for the organization for promotional and business use.

Copy and Print Room

AREA: 350 s.f.

HEIGHT: 8'-0"

SPECIAL CONDITIONS:

FINISHES

FLOOR: va tile
WALLS: gypsum board
CEILING: 2x4 acoustical lay-in tile

SYSTEMS

LIGHTING: general and task
PLUMBING: none
HVAC: VAV with perimeter heating

EQUIPMENT/FURNITURE:

cabinets and counter top, xerox machine and binding equipment.

RELATIONSHIPS:

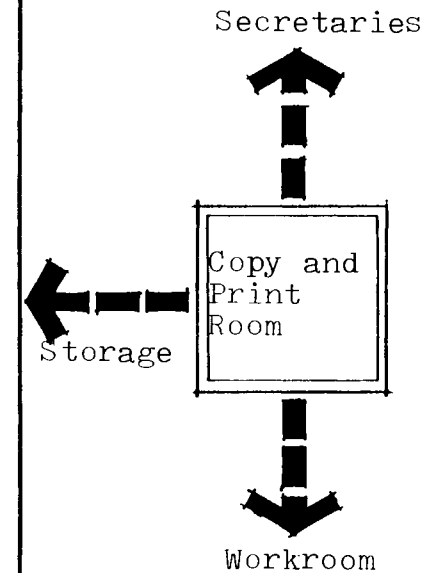

USER: Franchise Office, Football

FUNCTION/ACTIVITY:
secretarial and clerical duties for
the organization coaching staff.

Coaches
Secretary

AREA: 200 s.f.

HEIGHT: 8'-0"

SPECIAL CONDITIONS:

FINISHES

FLOOR: carpet
WALLS: gypsum board
CEILING: 2x4 acoustical lay-in tile

SYSTEMS

LIGHTING: general and task
PLUMBING: none
HVAC: VAV with perimeter heating

EQUIPMENT/FURNITURE:

desk with chair, typing wing, filing and
storage cabinets, two side chairs,
bookshelves

RELATIONSHIPS:

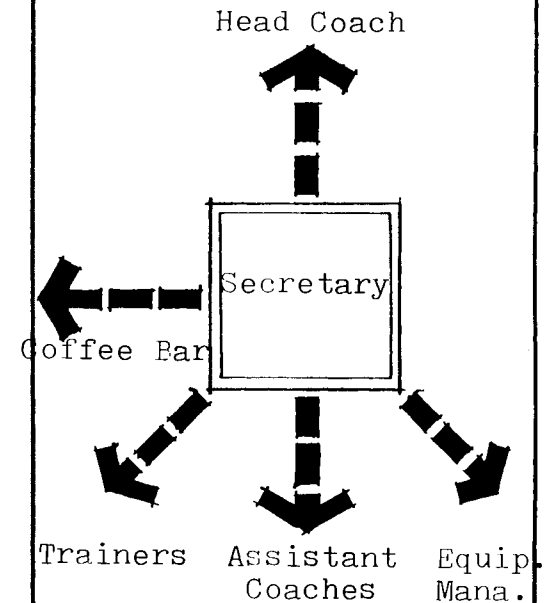

USER: Franchise Office, Football

FUNCTION/ACTIVITY:
Office for the head coach of the
football team

Head Coaches Office

AREA: 400 s.f.

HEIGHT: 8'-0"

SPECIAL CONDITIONS:

FINISHES

FLOOR: carpet
WALLS: gypsum board
CEILING: 2x4 acoustical lay-in tile

SYSTEMS

LIGHTING: general and task
PLUMBING: none
HVAC: VAV with perimeter heating

EQUIPMENT/FURNITURE:

desk with chair, two side chairs, credenza,
bookshelves, conference table for four,
couch and table.

RELATIONSHIPS:

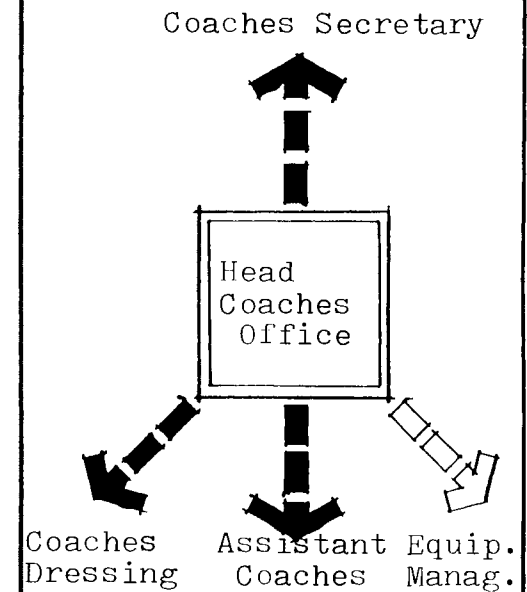

USER: Franchise Office, Football

FUNCTION/ACTIVITY:

Offices of the assistant coaches of the team used to direct the responsibilities of the assistant coaches and help the head coach

Assistant Coaches
Offices

AREA: 2,250 s.f. 250 s.f./ coach, 9 coaches

HEIGHT: 8'-0"

SPECIAL CONDITIONS:

FINISHES

FLOOR: Carpet
WALLS: gypsum board
CEILING: 2x4 acoustical lay-in tile

SYSTEMS

LIGHTING: general and task
PLUMBING: none
HVAC: VAV with perimeter heating

EQUIPMENT/FURNITURE:

desk with chair, two side chairs, bookshelves and conference table for four

RELATIONSHIPS:

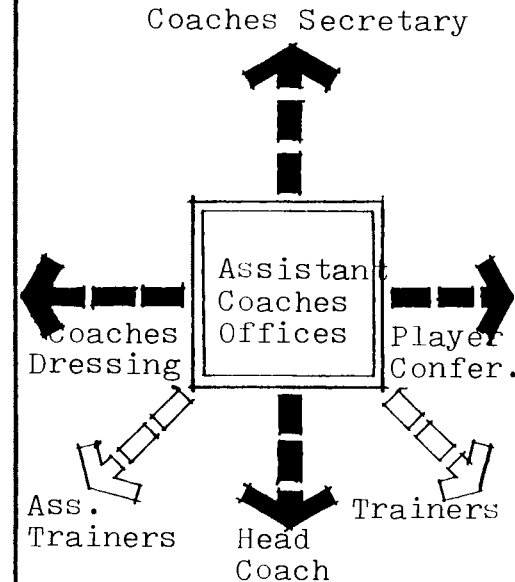

USER: Franchise Office, Football

FUNCTION/ACTIVITY:
Dressing area for the coaches use for
games and practices

Coaches Dressing
Room

AREA: 500 s,f.

HEIGHT: 8'-0"

SPECIAL CONDITIONS:
showers and restroom included

FINISHES

FLOOR: carpet, ceramic tile
WALLS: gypsum board, ceramic tile
CEILING: 2x4 acoustical lay-in tile, gypsum board

SYSTEMS

LIGHTING: general
PLUMBING: toilet, shower
HVAC: VAV with perimeter heating

EQUIPMENT/FURNITURE:

lockers with seating, couch,
seating area.

RELATIONSHIPS:

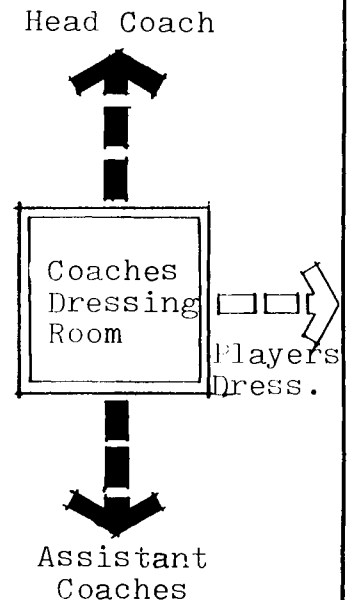

USER: Franchise Office, Football

FUNCTION/ACTIVITY:

Manager of the equipment for the players, orders, purchases and distributes all equipment for the players.

Equipment Manager

AREA: 200 s,f,

HEIGHT: 8'-0"

SPECIAL CONDITIONS:

FINISHES

FLOOR: carpet
WALLS: gypsum board
CEILING: 2x4 acoustical lay-in

SYSTEMS

LIGHTING: general and task
PLUMBING: none
HVAC: VAV with perimeter heating

EQUIPMENT/FURNITURE:

desk with chair, two side chairs, storage cabinet, bookshelves.

RELATIONSHIPS:

Coaches Secretary

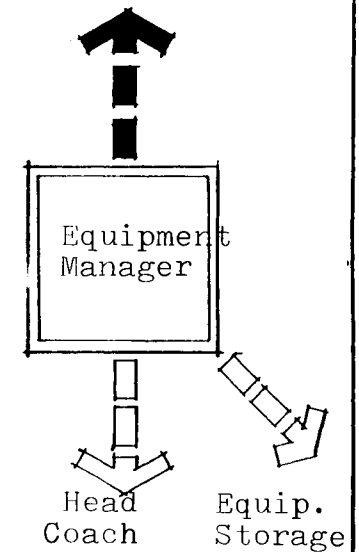

USER: Franchise Office, Football

FUNCTION/ACTIVITY:
Storage area for the team equipment and uniforms

Equipment Storage Room

AREA: 350 s.f.

HEIGHT: 8'-0"

SPECIAL CONDITIONS:
security, counter for issuing equipment

FINISHES

FLOOR: carpet
WALLS: gypsum board
CEILING: 2x4 acoustical lay-in tile

SYSTEMS

LIGHTING: general
PLUMBING: none
HVAC: VAV with perimeter heating

EQUIPMENT/FURNITURE:

shelves and cabinets for the storage of equipment

RELATIONSHIPS:

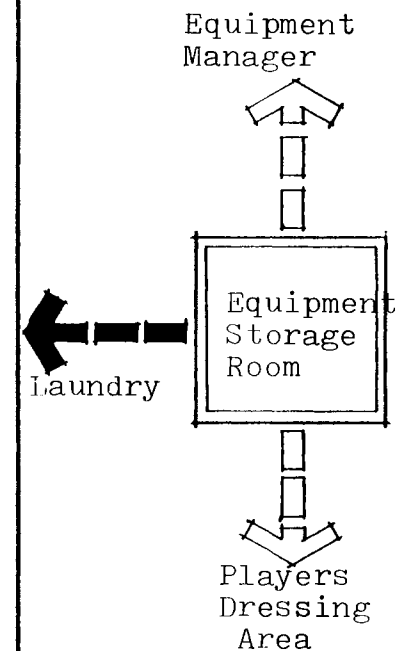

USER: Franchise Office, Football

FUNCTION/ACTIVITY:

Office for the head trainer of the team, oversees the other trainers and manages the training program.

Head Trainers Office

AREA: 250 s.f.

HEIGHT: 8'-0"

SPECIAL CONDITIONS:

FINISHES

FLOOR: carpet

WALLS: gypsum board

CEILING: 2x4 acoustical lay-in tile

SYSTEMS

LIGHTING: general and task

PLUMBING: none

HVAC: VAV with perimeter heating

EQUIPMENT/FURNITURE:

desk with chair, credenza, two side chairs, conference table for four, bookshelves.

RELATIONSHIPS:

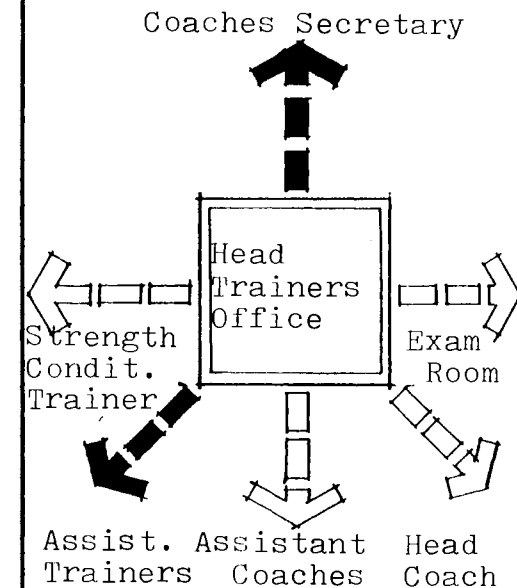

USER: Franchise Office, Football

FUNCTION/ACTIVITY:

Trainer for the strength and conditioning program for the players and also maintains the proper equipment for training purposes.

Strength and Conditioning Trainer

AREA: 200 s.f.

HEIGHT: 8'-0"

SPECIAL CONDITIONS:

FINISHES

FLOOR: carpet
WALLS: gypsum board
CEILING: 2x4 acoustical lay-in tile

SYSTEMS

LIGHTING: general and task
PLUMBING: none
HVAC: vav with perimeter heating

EQUIPMENT/FURNITURE:

desk with chair, two side chairs, shelves, filing cabinet for files on individual players.

RELATIONSHIPS:

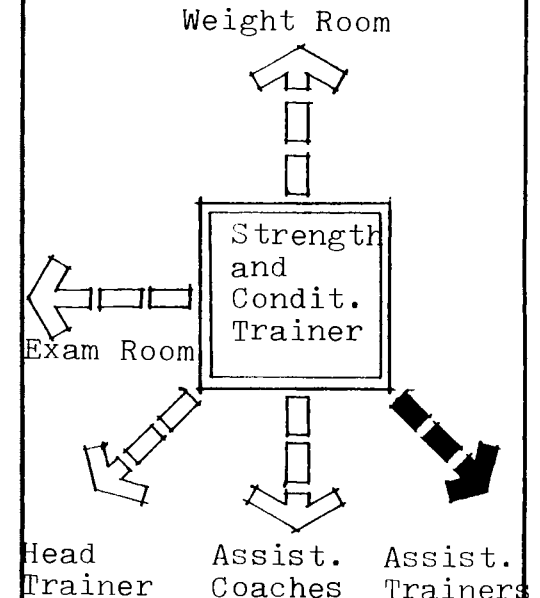

USER: Franchise Office, Football

FUNCTION/ACTIVITY:

Trains and helps set training schedules for individual players and help with the duties of the head trainer.

Assistant Trainer

AREA: 800 s.f. 4 at 200 s.f. each

HEIGHT: 8'-0"

SPECIAL CONDITIONS:

FINISHES

FLOOR: carpet
WALLS: gypsum board
CEILING: 2x4 acoustical lay-in tile

SYSTEMS

LIGHTING: general and task
PLUMBING: none
HVAC: VAV with perimeter heating

EQUIPMENT/FURNITURE:

desk with chair, two side chairs,
bookshelves and filing cabinet

RELATIONSHIPS:

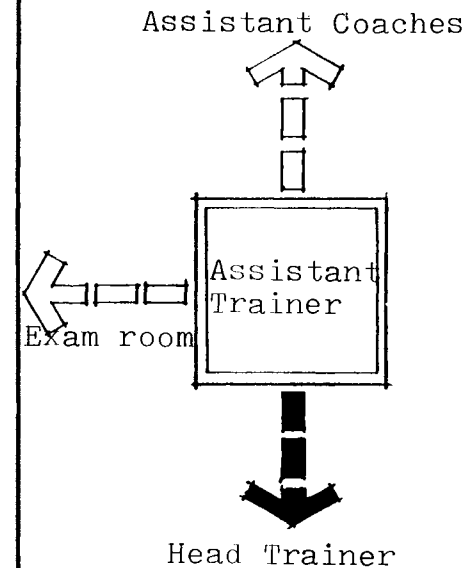

USER: Franchise Office, Football

FUNCTION/ACTIVITY:

Photographs events for team and publicity and releases photographs for promotional purposes.

Staff Photographer

AREA: 150 s.f.

HEIGHT: 8'-0"

SPECIAL CONDITIONS:

FINISHES

FLOOR: carpet

WALLS: gypsum board

CEILING: 2x4 acoustical lay-in tile

SYSTEMS

LIGHTING: general and task

PLUMBING: none

HVAC: VAV with perimeter heating

EQUIPMENT/FURNITURE:

desk with chair, shelves, storage cabinet, and two side chairs.

RELATIONSHIPS:

Secretary to
Public Relations

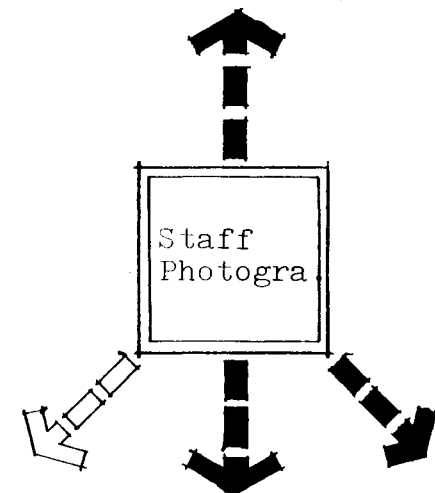

Media
Relations
Director

Photo.
Assist.

Dark-
room

USER: Franchise Office, Football

FUNCTION/ACTIVITY:
Assist with and share duties with the staff
photographer

Photographers
Assistant

AREA: 125 s.f.

HEIGHT: 8'-0"

SPECIAL CONDITIONS:

FINISHES

FLOOR: carpet
WALLS: gypsum board
CEILING: 2x4 acoustical lay-in tile

SYSTEMS

LIGHTING: general and task
PLUMBING: none
HVAC: VAV with perimeter heating

EQUIPMENT/FURNITURE:

desk with chair, two side chairs,
storage cabinet and bookshelves.

RELATIONSHIPS:

Staff Photo.

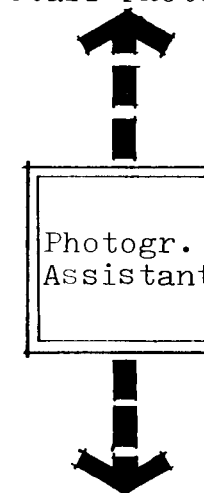

Darkroom

USER: Franchise Office, Football

FUNCTION/ACTIVITY:

For the processing and development of pictures by the staff photogragpher and his assistant

Darkroom

AREA: 50 s.f.

HEIGHT: 8'-0"

SPECIAL CONDITIONS:
darkroom equipment

FINISHES

FLOOR: va tile
WALLS: gypsum board, painted black
CEILING: 2x4 acoustical lay-in tile, black

SYSTEMS

LIGHTING: general and special
PLUMBING: as required for darkroom set-up
HVAC: VAV with perimeter heating

EQUIPMENT/FURNITURE:

Storage for photo-developing equipment, lay tables and equipment required for a darkroom

RELATIONSHIPS:

Staff Photo.

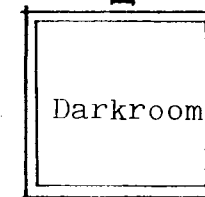

Photographer
Assistant

USER: Franchise Office, Football

FUNCTION/ACTIVITY:
for the physical development and training
of the players.

Weight Room

AREA: 2500 s.f. for an occupancy of 30

HEIGHT: 9'-0"

SPECIAL CONDITIONS:
ground floor

FINISHES

FLOOR: carpet
WALLS: gypsum board
CEILING: 2x4 acoustical lay-in tile

SYSTEMS

LIGHTING: general
PLUMBING: none
HVAC: VAV with perimeter heating

EQUIPMENT/FURNITURE:

weight equipment as required

RELATIONSHIPS:

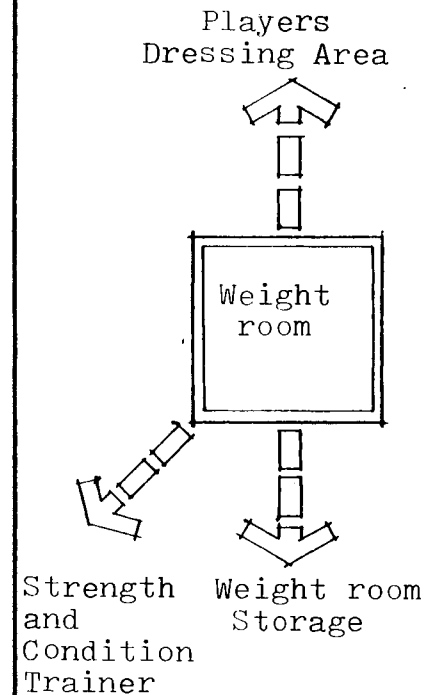

USER: Franchise Office, Football

FUNCTION/ACTIVITY:

storage of extra equipment and loose weights for the weight room

Weight Room
Storage

AREA: 200 s.f.

HEIGHT: 9'-0"

SPECIAL CONDITIONS:
security

FINISHES

FLOOR: va tile

WALLS: gypsum board

CEILING: 2x4 acoustical lay-in tile

SYSTEMS

LIGHTING: general

PLUMBING: none

HVAC: VAV with perimeter heating

EQUIPMENT/FURNITURE:

shelves for storage

RELATIONSHIPS:

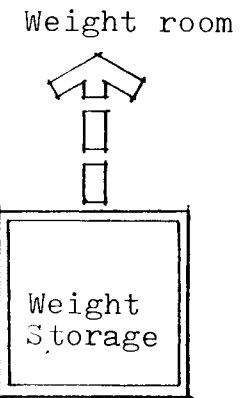

USER: Franchise Office, Football

FUNCTION/ACTIVITY:

used by both football and basketball organizations for uniform and equipment cleaning

Laundry Room

AREA: 300 s.f.

HEIGHT: 8'-0"

SPECIAL CONDITIONS:

FINISHES

FLOOR: va tile

WALLS: gypsum board

CEILING: 2x4 acoustical lay-in tile

SYSTEMS

LIGHTING: general

PLUMBING: as required

HVAC: VAV with perimeter heating

EQUIPMENT/FURNITURE:

as required

RELATIONSHIPS:

Players
Dressing Area

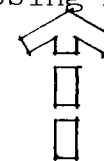

Equipment
Storage

USER: Franchise Office, Football

FUNCTION/ACTIVITY:

dressing area for the team prior and after the game and for practices.

Home Dressing Room

AREA: 2500 s.f.

HEIGHT: 9'-0"

SPECIAL CONDITIONS:

FINISHES

FLOOR: carpet

WALLS: gypsum board

CEILING: 2x4 acoustical lay-in tile

SYSTEMS

LIGHTING: general

PLUMBING: none

HVAC: VAV with perimeter heating

EQUIPMENT/FURNITURE:

lockers with bench type seating, chalkboard and area for discussions at halftime etx.

RELATIONSHIPS:

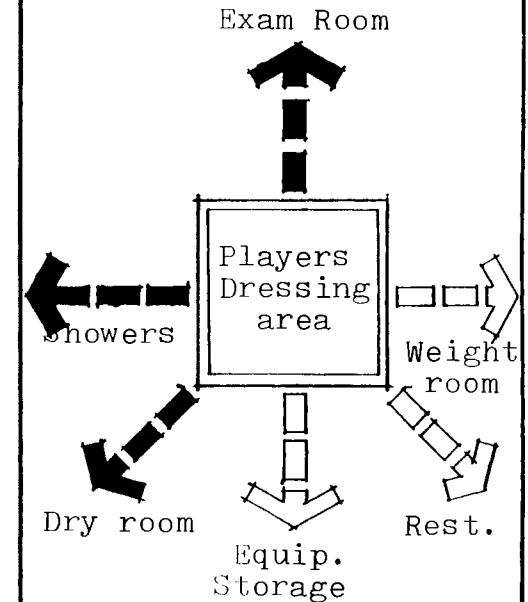

USER: Franchise Office, Football

FUNCTION/ACTIVITY:

Shower and dry area for the players for clean-up after a game or practice.

Home shower and Dry room

AREA: 350 s.f.

HEIGHT: 9'-0"

SPECIAL CONDITIONS:

FINISHES

FLOOR: ceramic tile

WALLS: ceramic tile

CEILING: gypsum board

SYSTEMS

LIGHTING: general

PLUMBING: showers with sinks

HVAC: VAV with perimeter heating, ventilated

EQUIPMENT/FURNITURE:

shower heads, sinks, mirrors, hair and hand dryers, towel storage and towel hangers.

RELATIONSHIPS:

Players Dressing Area

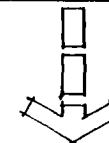
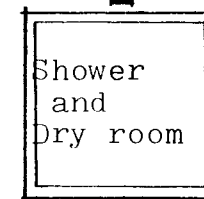

Restrooms

USER: Franchise Office, Football

FUNCTION/ACTIVITY:
rest room facilities for the home
players

Home Rest room

AREA: 250 s.f.

HEIGHT: 9'-0"

SPECIAL CONDITIONS:

FINISHES

FLOOR: ceramic tile
WALLS: ceramic tile
CEILING: gypsum board

SYSTEMS

LIGHTING: general
PLUMBING: toilets
HVAC: VAV with perimeter heating, ventilation

EQUIPMENT/FURNITURE:

toilets and toilet partitions.

RELATIONSHIPS:

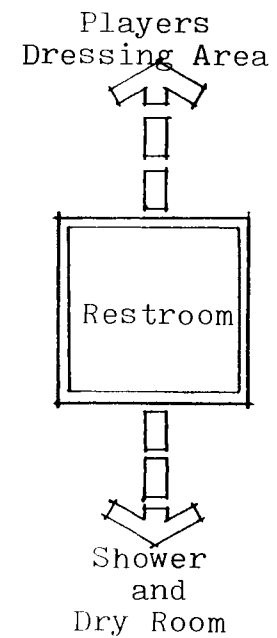

USER: Franchise Office, Football

FUNCTION/ACTIVITY:

Examination and treatment room for injuries
pre game wrapping and physical treatment.

Trainers Examination
Room

AREA: 700 s.f.

HEIGHT: 9'-0"

SPECIAL CONDITIONS:

FINISHES

FLOOR: carpet
WALLS: gypsum board
CEILING: 2x4 acoustical lay-in tile

SYSTEMS

LIGHTING: general and task
PLUMBING: sink
HVAC: VAV with perimeter heating

EQUIPMENT/FURNITURE:

tables for wrapping, counters and storage
area.

RELATIONSHIPS:

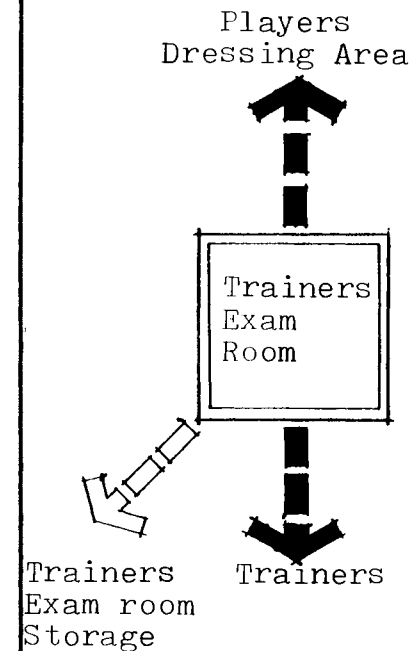

USER: Franchise Office, Football

FUNCTION/ACTIVITY:

Storage for equipment and materials
for the trainers use in the examination
room

Trainers Examination
Room Storage

AREA: 100 s.f.

HEIGHT: 9'-0"

SPECIAL CONDITIONS:
security

FINISHES

FLOOR: va tile
WALLS: gypsum board
CEILING: 2x4 acoustical lay-in tile

SYSTEMS

LIGHTING: general
PLUMBING: none
HVAC: none

EQUIPMENT/FURNITURE:

shelves for storage of material.

RELATIONSHIPS:

Trainers Exam



Trainers
Exam room
Storage

USER: Franchise Office, Football

FUNCTION/ACTIVITY:
dressing area for the visiting coaches
for scrimmages and games.

Visiting Coaches
Dressing Room

AREA: 350 s.f.

HEIGHT: 9'-0"

SPECIAL CONDITIONS:
includes shower and toilet

FINISHES

FLOOR: carpet
WALLS: gypsum board
CEILING: 2x4 acoustical lay-in tile

SYSTEMS

LIGHTING: general
PLUMBING: none
HVAC: VAV with perimeter heating

EQUIPMENT/FURNITURE:

lockers with seating

RELATIONSHIPS:

Players
Dressing Area



USER: Franchise Office, Football

FUNCTION/ACTIVITY:

Dressing area for the visiting football club for games or scrimmages

Visitors Dressing Room

AREA: 2000 s.f.

HEIGHT: 9'-0"

SPECIAL CONDITIONS:

FINISHES

FLOOR: carpet

WALLS: gypsum board

CEILING: 2x4 acoustical lay-in tile

SYSTEMS

LIGHTING: general

PLUMBING: none

HVAC: VAV with perimeter heating, ventiaalted

EQUIPMENT/FURNITURE:

lockers with bench type seating, chalkboard and discussion area.

RELATIONSHIPS:

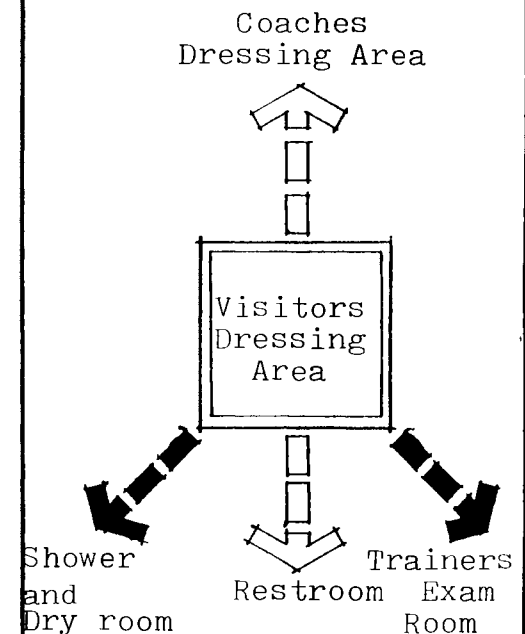

USER: Franchise Office, Football

FUNCTION/ACTIVITY:

Shower and clean-up area for players
after the game and scrimmage

Shower and dry Room
for Visitors

AREA: 300 s.f.

HEIGHT: 9'-0"

SPECIAL CONDITIONS:

FINISHES

FLOOR: ceramic tile

WALLS: ceramic tile

CEILING: gypsum board

SYSTEMS

LIGHTING: general

PLUMBING: shower heads, toilets

HVAC: VAV with perimeter heating

EQUIPMENT/FURNITURE:

towel shelf storage, towel hangers,
shower heads, dressing benches, sinks
mirrors, hair and hand dryers

RELATIONSHIPS:

Players
Dressing Area

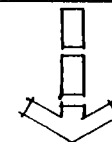
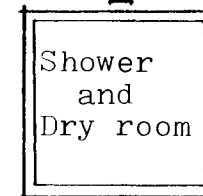

Restrooms

USER: Franchise Office, Football

FUNCTION/ACTIVITY:
treatment and exam room for trainers
to work on players for pre-game
wrapping or injuries.

Trainers Exam and
Treatment Room

AREA: 500 s.f.

HEIGHT: 9'-0"

SPECIAL CONDITIONS:

FINISHES

FLOOR: carpet
WALLS: gypsum board
CEILING: 2x4 acoustical lay-in tile

SYSTEMS

LIGHTING: general and task
PLUMBING: sink
HVAC: VAV with perimeter heating

EQUIPMENT/FURNITURE:

wrapping tables, counter, equipment
storage

RELATIONSHIPS:

Players
Dressing Area

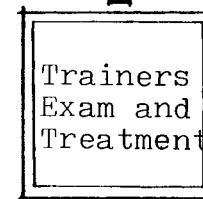

USER: Franchise Office, Football

FUNCTION/ACTIVITY:

restroom facilities for the visiting team.

Visitors Restroom

AREA: 200 s.f.

HEIGHT: 9'-0"

SPECIAL CONDITIONS:

FINISHES

FLOOR: ceramic tile
WALLS: ceramic tile
CEILING: gypsum board

SYSTEMS

LIGHTING: general
PLUMBING: toilets
HVAC: VAV with perimeter heating, ventilated

EQUIPMENT/FURNITURE:

toilet with toilet partitions.

RELATIONSHIPS:

Shower and Dry

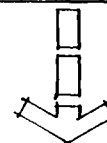

Players
Dressing Area

USER: Service

FUNCTION/ACTIVITY:

a separate service entrance located away from the public and be used for concession and maintenance goods.

Service Entrance

AREA:

HEIGHT:

SPECIAL CONDITIONS:

controlled access and directly accessible from a main public road, large enough to accomodate semi-trailers.

FINISHES

FLOOR:

WALLS:

CEILING:

SYSTEMS

LIGHTING:

PLUMBING:

HVAC:

EQUIPMENT/FURNITURE:

RELATIONSHIPS:

Service Yard



USER: Service

FUNCTION/ACTIVITY:

For the disposal of trash and refuse
after events for pick-up by city services.

Trash and Refuse
Yard

AREA:

HEIGHT:

SPECIAL CONDITIONS:

FINISHES

FLOOR: concrete or asphalt

WALLS:
CEILING:

SYSTEMS

LIGHTING: exterior

PLUMBING:

HVAC:

EQUIPMENT/FURNITURE:

RELATIONSHIPS:

Service Yard

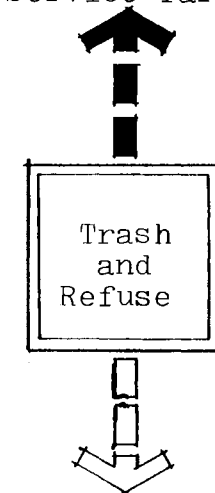

Service Dock

USER: Service

FUNCTION/ACTIVITY:

For the receiving of goods to the complex and large enough to handle semi-trailers.

Service Yard

AREA:

HEIGHT:

SPECIAL CONDITIONS:

should be easily accessible from the service entrance and screened from the public

FINISHES

FLOOR:

WALLS:

CEILING:

SYSTEMS

LIGHTING:

PLUMBING:

HVAC:

EQUIPMENT/FURNITURE:

RELATIONSHIPS:

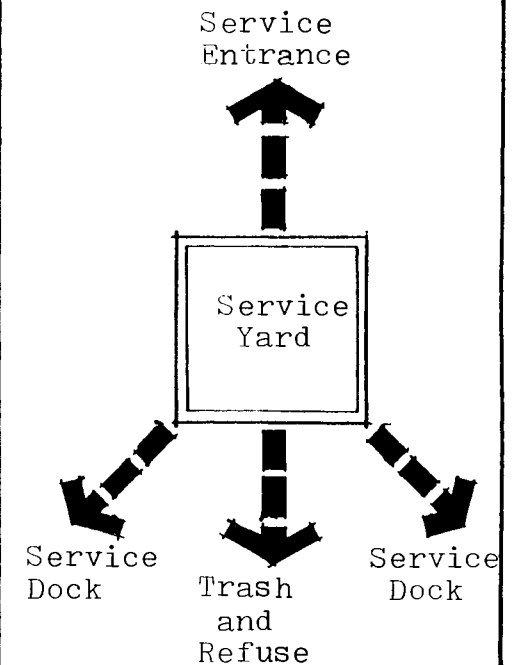

USER: Service

FUNCTION/ACTIVITY:

For the loading and unloading of materials for stadium maintenance and goods and upcoming exhibits if necessary.

Service Dock

AREA: 450 s.f. 15x30'

HEIGHT:

SPECIAL CONDITIONS:

FINISHES

FLOOR: concrete

WALLS: concrete

CEILING:

SYSTEMS

LIGHTING: exterior lighting

PLUMBING: none

HVAC: none

EQUIPMENT/FURNITURE:

RELATIONSHIPS:

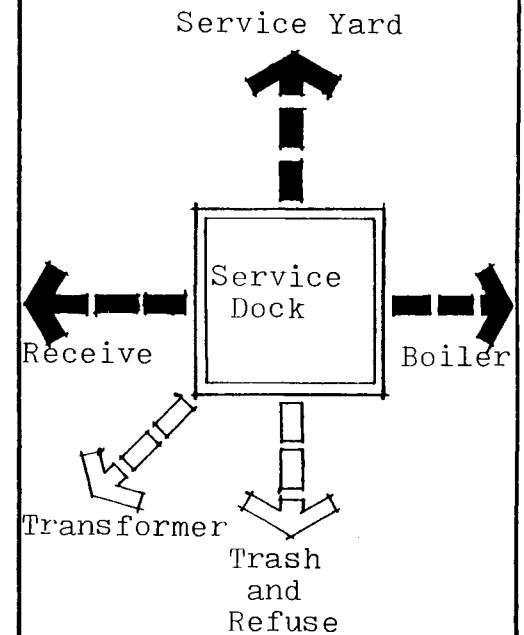

USER: Service

FUNCTION/ACTIVITY:

For the loading and unloading of concessions for the complex, shall be a controlled point and large enough to handle semi-trailers.

Service Dock

AREA: 450 s.f. 15x30'

HEIGHT:

SPECIAL CONDITIONS:

FINISHES

FLOOR: concrete
WALLS: concrete
CEILING:

SYSTEMS

LIGHTING: exterior lighting
PLUMBING: none
HVAC: none

EQUIPMENT/FURNITURE:

RELATIONSHIPS:

Service Yard

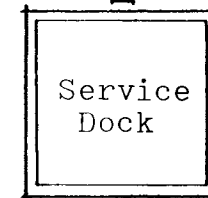

Receiving

USER: Service

FUNCTION/ACTIVITY:

for the receiving of goods and materials
and packaging of goods.

Receiving Room

AREA: 200 s.f.

HEIGHT: 15'-0"

SPECIAL CONDITIONS:

FINISHES

FLOOR: concrete
WALLS: concrete block
CEILING: exposed structure

SYSTEMS

LIGHTING: general
PLUMBING: none
HVAC: none

EQUIPMENT/FURNITURE:

none

RELATIONSHIPS:

Service Dock

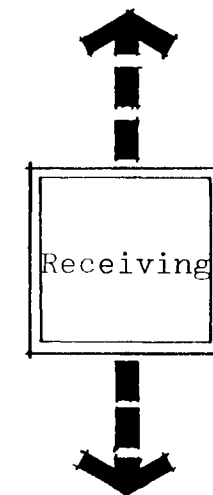

Main
Storage
Facility

USER: Service

FUNCTION/ACTIVITY:

for the storage of concessions and goods for events. Used as the main storage facility for concessions for the facility.

Commissary

AREA: 2000 s.f.

HEIGHT: 9'-0"

SPECIAL CONDITIONS:

FINISHES

FLOOR: concrete
WALLS: concrete block
CEILING: exposed structure

SYSTEMS

LIGHTING: general
PLUMBING: none
HVAC: single system

EQUIPMENT/FURNITURE:

two walk in freezers for the storage of perishable goods, 15x15' each.

RELATIONSHIPS:

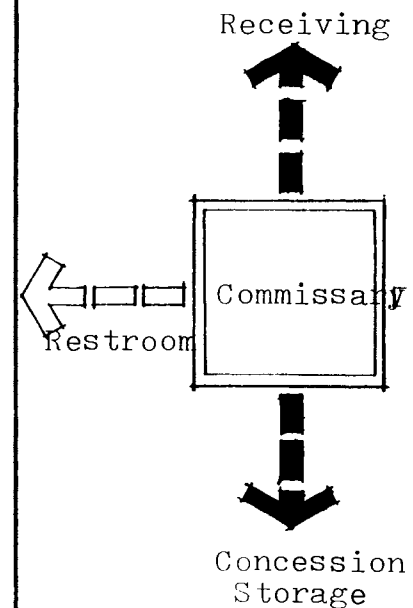

USER: Service

FUNCTION/ACTIVITY:

For the storage of stadium and maintenance goods as a central storage point

Main Storage Facility

AREA: 4000 s.f.

HEIGHT: 15'-0"

SPECIAL CONDITIONS:

FINISHES

FLOOR: concrete

WALLS: concrete block

CEILING: exposed structure

SYSTEMS

LIGHTING: general

PLUMBING: none

HVAC: single system

EQUIPMENT/FURNITURE:

none

RELATIONSHIPS:

Receiving

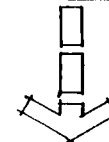

Restroom

USER: Service

FUNCTION/ACTIVITY:

for the use of employees in the storage
and dock areas.

Restrooms

AREA: 50 s.f.

HEIGHT: 8'-0"

SPECIAL CONDITIONS:

FINISHES

FLOOR: ceramic tile
WALLS: ceramic tile
CEILING: 2x4 acoustical lay-in tile

SYSTEMS

LIGHTING: general and task
PLUMBING: toilet with sink
HVAC: VAV with perimeter heating, ventilated

EQUIPMENT/FURNITURE:

sink with cabinet, mirror, soap dispenser,
toilet.

RELATIONSHIPS:

Main Storage
Facility

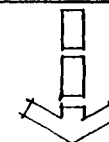
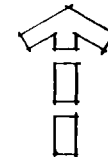

Commissary

USER: Service

FUNCTION/ACTIVITY:

Move goods and freight from the storage areas to the different levels of the stadium

Freight Elevator

AREA: 50 s.f. 5x7 elevator

HEIGHT:

SPECIAL CONDITIONS:

FINISHES

FLOOR: tile

WALLS:

CEILING:

SYSTEMS

LIGHTING: general

PLUMBING: none

H V A C: none

EQUIPMENT/FURNITURE:

RELATIONSHIPS:

Main Storage Fac.

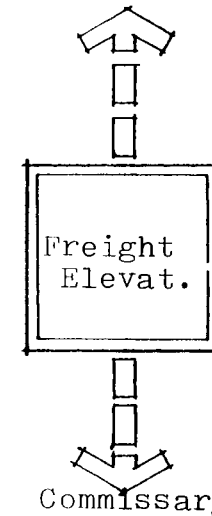

USER: Service

FUNCTION/ACTIVITY:

For the storage of concession items on each floor level, should be large enough to accomodate concessions for two consecutive events.

Concession
Storage
Facility

AREA: 400 s.f.

HEIGHT: 9'-0

SPECIAL CONDITIONS:

FINISHES

FLOOR: concrete
WALLS: concrete block
CEILING: exposed structure

SYSTEMS

LIGHTING: general
PLUMBING: none
HVAC: none

EQUIPMENT/FURNITURE:

24" deep shelving for the storage of concession goods, one 5x10' walk in freezer for perishable goods.

RELATIONSHIPS:

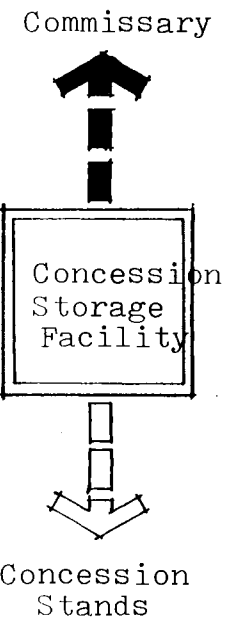

USER: Service

FUNCTION/ACTIVITY:

To provide an area for the movement of materials from the exterior of the building and bulk storage area to the arena playing area

Service Ramp

AREA: 25 feet wide

HEIGHT: 20'

SPECIAL CONDITIONS:

FINISHES

FLOOR: concrete
WALLS: concrete block
CEILING: exposed structure

SYSTEMS

LIGHTING: general
PLUMBING: none
HVAC: none

EQUIPMENT/FURNITURE:

RELATIONSHIPS:

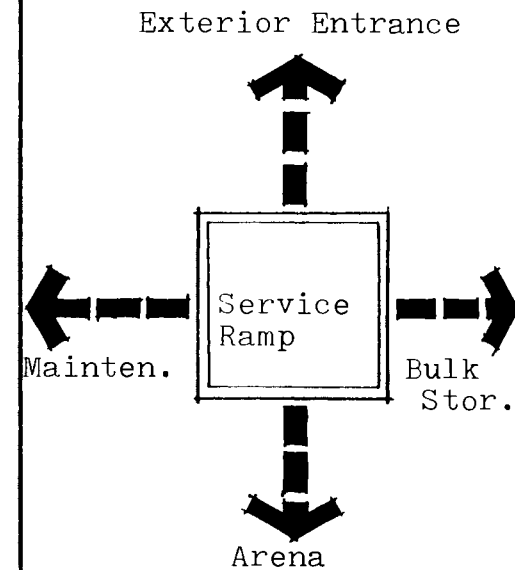

USER: Service

FUNCTION/ACTIVITY:

storage area for temporary seats and large storage items including separate floorings

Bulk Storage

AREA: 5000 s.f.

HEIGHT:

SPECIAL CONDITIONS:

located near the arena floor

FINISHES

FLOOR: concrete
WALLS: concrete block
CEILING: exposed structure

SYSTEMS

LIGHTING: general
PLUMBING: none
HVAC: single system

EQUIPMENT/FURNITURE:

RELATIONSHIPS:

Service Ramp



USER: Service

FUNCTION/ACTIVITY:
Storage of materials and equipment
for the janitor

Janitors Area

AREA: 100 s.f. each, two per floor

HEIGHT: 9'-0"

SPECIAL CONDITIONS:

FINISHES

FLOOR: concrete
WALLS: concrete block
CEILING: exposed structure

SYSTEMS

LIGHTING: general
PLUMBING: mop sink
HVAC: none

EQUIPMENT/FURNITURE:

shelves for the storage of equipment
and materials.

RELATIONSHIPS:

Men Employee
Dressing Area



Women Employee
Dressing Area

USER: Service

FUNCTION/ACTIVITY:

Used as a dressing and clean-up area for event employees. Used for uniform change, showers, and break area.

Men Employees
Dressing Area

AREA: 3,500 s.f. 350 persons

HEIGHT: 9'-0"

SPECIAL CONDITIONS:

FINISHES

FLOOR: Concrete or va Tile
WALLS: concrete block
CEILING: 2x4 acoustical lay-in tile

SYSTEMS

LIGHTING: general
PLUMBING: 3 water closets, 2 urinals, 3 showers
HVAC: VAV with perimeter heating

EQUIPMENT/FURNITURE:

lockers for 350, benches, break tables, showers, urinals, water closet, sinks

RELATIONSHIPS:

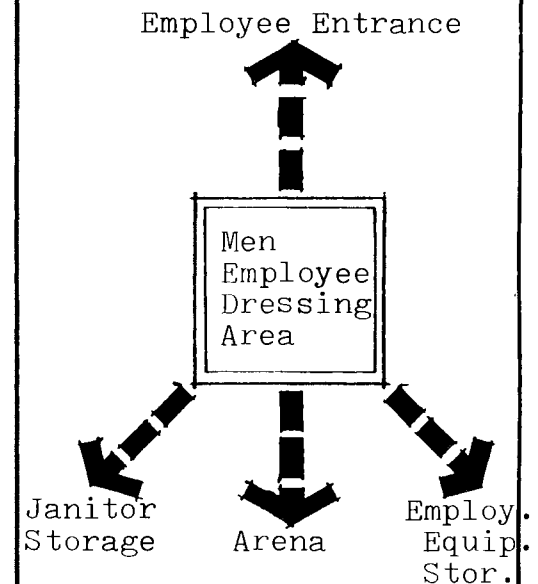

USER: Service

FUNCTION/ACTIVITY:

Used as a dressing and clean-up area for event employees. Used for uniform change, showers and break area.

Women
Employees Dressing
Area

AREA: 3500 s.f. to accomodate 350 employees

HEIGHT: 9'-0"

SPECIAL CONDITIONS:

FINISHES

FLOOR: concrete or va tile
WALLS: concrete block
CEILING: 2x4 acoustical lay-in tile

SYSTEMS

LIGHTING: general
PLUMBING: 4 water closets, 3 showers, 5 sinks
HVAC: VAV with perimeter heating

EQUIPMENT/FURNITURE:

Lockers for 350, benches, break tables, showers, and clean-up area

RELATIONSHIPS:

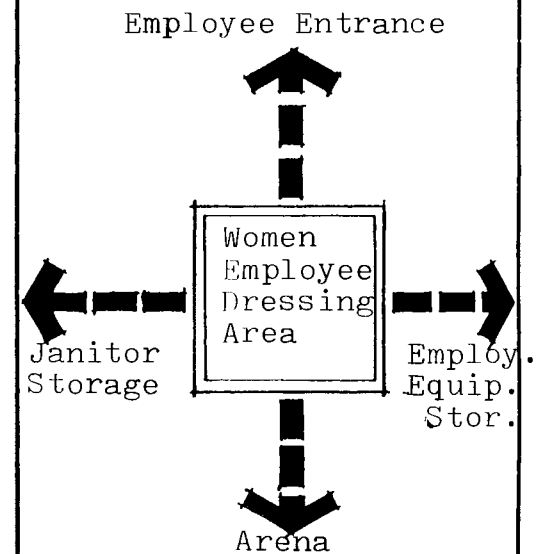

USER: Service

FUNCTION/ACTIVITY:

storage area for equipment and materials used by the event employees for clean-up after events

Employee Equipment storage

AREA: 200 s.f. each

HEIGHT: 9'-0"

SPECIAL CONDITIONS:

FINISHES

FLOOR: concrete
WALLS: concrete block
CEILING: exposed structure

SYSTEMS

LIGHTING: general
PLUMBING: mop sink
HVAC: none

EQUIPMENT/FURNITURE:

shelves for the storage of equipment and materials

RELATIONSHIPS:

Men Employee Dressing Area

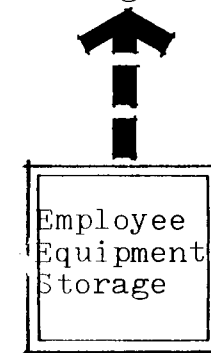

Women Employee Dressing Area

USER: Service

FUNCTION/ACTIVITY:

Room for the use of boilers and chillers for the building heating and cooling system.

Boiler room

AREA: 10,000 s.f.

HEIGHT: 25'

SPECIAL CONDITIONS:

walls, ceiling, and floors shall be of concrete for fire and safety protection

FINISHES

FLOOR: concrete
WALLS: concrete
CEILING: concrete

SYSTEMS

LIGHTING: general
PLUMBING: sink
HVAC: none

EQUIPMENT/FURNITURE:

RELATIONSHIPS:

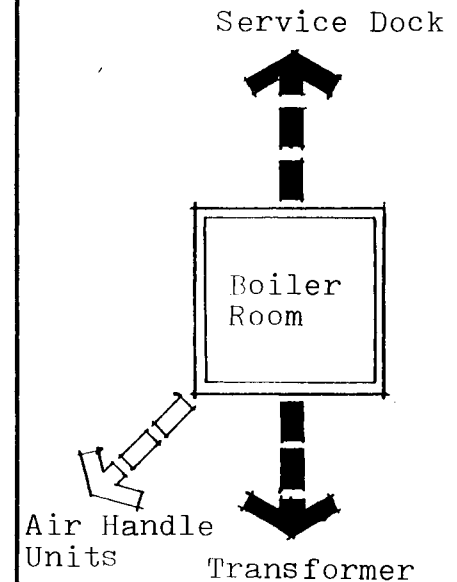

USER: Service

FUNCTION/ACTIVITY:

Area for the air handling units to distribute the heating and cooling and intake of fresh air.

Air Handling Units

AREA: 25,000 s.f.

HEIGHT: 20'

SPECIAL CONDITIONS:

next to an exterior wall for the intake of fresh air.

FINISHES

FLOOR: concrete
WALLS: concrete block
CEILING: exposed structure

SYSTEMS

LIGHTING: general
PLUMBING: none
HVAC: none

EQUIPMENT/FURNITURE:

none

RELATIONSHIPS:

Boiler Room

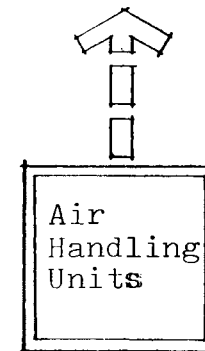

USER: Service

FUNCTION/ACTIVITY:

area for the transformer, switchgear,
and substation.

Transformer

AREA: 2000 s.f.

HEIGHT: 9'

SPECIAL CONDITIONS:

FINISHES

FLOOR: concrete
WALLS: concrete block
CEILING: exposed structure

SYSTEMS

LIGHTING: general
PLUMBING: none
HVAC: none

EQUIPMENT/FURNITURE:

concrete pad for transformer

RELATIONSHIPS:

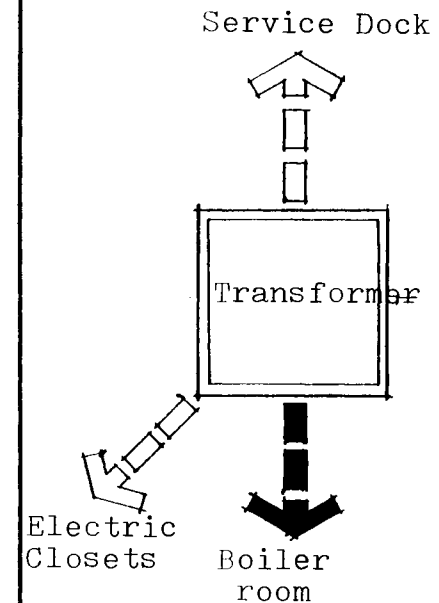

USER: Service

FUNCTION/ACTIVITY:

Room for all electrical equipment for the building on every floor. Includes telephone service

Electrical Closets

AREA: 50 s.f. each, 5x4 for 10 000 s.f. floor area

HEIGHT: 9'-0"

SPECIAL CONDITIONS:

FINISHES

FLOOR: concrete
WALLS: concrete block
CEILING: exposed structure

SYSTEMS

LIGHTING: general
PLUMBING: none
HVAC: none

EQUIPMENT/FURNITURE:
none

RELATIONSHIPS:

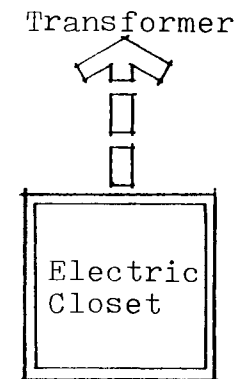

USER: Service

FUNCTION/ACTIVITY:

The arena should be as flexible as possible so that almost any function could work.

Arena

AREA: 100,000 s.f.

HEIGHT: open to ceiling

SPECIAL CONDITIONS:

FINISHES

FLOOR: flexible, hard, durable

WALLS:

CEILING: exposed structure

SYSTEMS

LIGHTING: as required

PLUMBING: none

HVAC: single zone system

EQUIPMENT/FURNITURE:

RELATIONSHIPS:

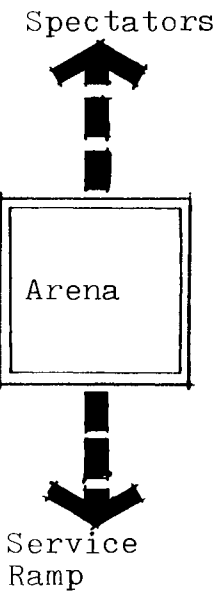

USER: Service

FUNCTION/ACTIVITY:

Used as a space for offices of shows, rodeo animal storage, circus offices and circus animals, etc

Livestock
Storage area

AREA: 10,000 s.f.

HEIGHT: exposed structure

SPECIAL CONDITIONS:

Used as a transition area for animals, long term show offices, circus animals and etc.

FINISHES

FLOOR: concrete
WALLS: concrete block
CEILING: exposed structure

SYSTEMS

LIGHTING: general
PLUMBING: none
HVAC: VAV with perimeter heating

EQUIPMENT/FURNITURE:
none

RELATIONSHIPS:



OKLAHOMA STATE UNIVERSITY LIBRARY

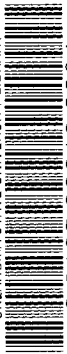

3 6135 00010 6684