

KINETIC STUDY OF THERMOLYTIC REACTIONS OF
ETHYLPHENOLS AND SOLVENT DODECANE

By

PEIZHENG ZHOU
ii

Diploma
Beijing Petroleum Institute
Beijing, China
1955

Diploma
Graduate College of
Beijing Petroleum Institute
Beijing, China
1959

Submitted to the Faculty of the Graduate College
of the Oklahoma State University
in partial fulfillment of the requirements
for the Degree of
DOCTOR OF PHILOSOPHY
December, 1984

Thesis
1984 D
263k
cop. 2



KINETIC STUDY OF THERMOLYTIC REACTIONS OF
ETHYLPHENOLS AND SOLVENT DODECANE

Thesis Approved:

Billy L. Lyness

Thesis Adviser

[Signature]

Darryl L. Fortch

Mayis Seapan

[Signature]

Norman D. Mumken

Dean of the Graduate College

PREFACE

The kinetics of thermolytic reactions of three isomeric ethylphenols in solvent dodecane, as well as of o-ethylphenol and of dodecane separately, were studied. Pseudo first order rate equations were found to apply satisfactorily to the disappearance of these compounds and related kinetic constants were obtained.

A free radical chain reaction mechanism is proposed for dodecane thermolysis and a molecular decomposition mechanism is suggested for the thermolysis of ethylphenols. Experimental observations, including thermal conversion, product distribution, mutual effects of the substrate and the solvent, and the effect of molecular hydrogen on the thermolysis of ethylphenols and dodecane, are explained on the basis of these mechanisms.

I wish to express my sincere gratitude to all the people who kindly assisted me during my stay at the Oklahoma State University. In particular, I am especially indebted to Dr. Billy L. Crynes, my major advisor, for his invaluable help, intelligent guidance and kindest concern.

Appreciation is also expressed to members of the Advisory Committee, Dr. Edmund J. Eisenbraun, Dr. Mayis Seapan, Dr. Jan Wagner, Dr. Gary L. Foutch, and also to Dr. Robert L. Robinson, Jr., for their kind help and advisement.

Dr. Otis C. Dermer and Dr. Clarence M. Cunningham deserve special thanks for their patient assistance and contributions.

The assistance of Dr. Sterling L. Burks and Mr. Greg Smith of the Water Quality Research Laboratory, and Mr. Norman Pereira of the Department of Chemistry, for providing mass spectrographic analyses for some of my samples, is appreciated.

Financial support for the duration of this study was gratefully received from the School of Chemical Engineering and the University Center for Energy Research, Oklahoma State University.

I owe an unspeakable debt of gratitude to my wife, Shining, and to my son and daughter, Wei and Yi, for their loving understanding, support and encouragement during my entire study.

TABLE OF CONTENTS

| Chapter | Page |
|--|------|
| I. INTRODUCTION | 1 |
| II. OXYGEN COMPOUNDS IN COAL-DERIVED LIQUIDS | 3 |
| A. Oxygen in Coal-Derived Liquids. | 3 |
| 1. Oxygen Content of Coal-Derived Liquids. | 4 |
| 2. Oxygen Compounds and Functions in Coal-Derived Liquids | 4 |
| B. Thermal Reactions of Oxygen Compounds Related to Coals and Coal Liquids | 15 |
| 1. Thermodynamic Considerations. | 15 |
| 2. Thermal Reactions of Model Oxygen Compounds in the Absence of Hydrogen Donors and Molecular Hydrogen. | 18 |
| 3. Thermolysis of Coal-Derived Liquids in the Absence of Hydrogen Donors. | 24 |
| 4. Thermal Reactions of Model Oxygen Compounds with Hydrogen Donors. | 26 |
| 5. Thermal Reactions of Oxygen Compounds with Molecular Hydrogen. | 34 |
| C. Catalytic Hydrogenolysis of Oxygen Compounds in Coal Liquids | 35 |
| 1. Catalytic Hydrodeoxygenation of Oxygen-Containing Model Compounds. | 35 |
| 2. Hydrodeoxygenation of Coal-Derived Liquids. | 37 |
| 3. Kinetics of Hydrodeoxygenation of Coal Liquids. | 39 |
| D. Hydrogen Consumption and Coke Formation in Coal Liquid Upgrading. | 41 |
| 1. Hydrogen Consumption During Hydro-Upgrading | 42 |
| 2. Role of Oxygen Compounds in Coke Formation. | 43 |
| E. Concluding Remarks. | 45 |
| III. EXPERIMENTAL APPARATUS | 46 |
| A. The Reactor System. | 47 |
| 1. The Flow Scheme | 47 |
| 2. The Reactor | 50 |
| B. Materials | 51 |

| | |
|--|-----|
| IV. EXPERIMENTAL RESULTS | 53 |
| A. Thermolysis of Dodecane | 55 |
| 1. Thermolytic Conversion of Dodecane. | 56 |
| 2. Product Distribution of Dodecane Thermolysis. | 57 |
| B. Thermolysis of o-Ethylphenol | 68 |
| C. Thermolysis of o-Ethylphenol in Dodecane. | 75 |
| 1. Thermolysis of o-Ethylphenol in Dodecane under Nitrogen Atmosphere at 623 K. | 75 |
| 2. Thermolysis of o-Ethylphenol in Dodecane under Differing Conditions. | 79 |
| 3. Thermolysis of o-Ethylphenol in Dodecane in Hydrogen Atmosphere. | 80 |
| D. Thermolysis of Para and Meta Ethylphenols in Dodecane | 85 |
| V. DISCUSSION OF RESULTS. | 92 |
| A. Precision and Accuracy of the Data. | 92 |
| B. Thermolytic Reactions of Dodecane | 97 |
| 1. Thermal Reactivity. | 97 |
| 2. Reaction Kinetics | 98 |
| 3. Product Distribution. | 102 |
| 4. Effect of Hydrogen Environment. | 108 |
| 5. Gas Analysis. | 109 |
| 6. Reaction Mechanism. | 110 |
| C. Thermolytic Reactions of o-Ethylphenol. | 122 |
| 1. Reaction Order. | 122 |
| 2. Reaction Kinetics | 125 |
| 3. Product Distribution. | 126 |
| 4. Reaction Mechanism. | 128 |
| D. Thermolytic Reactions of o-Ethylphenol in Solvent | 134 |
| 1. Reaction Kinetics | 137 |
| 2. Thermolysis of o-Ethylphenol in Dodecane under Different Conditions and Nitrogen Atmosphere. | 137 |
| 3. Thermolysis of o-Ethylphenol in Dodecane under Hydrogen Environment | 141 |
| 4. Effect of Hydrogen on Dodecane Conversion with or without o-Ethylphenol | 143 |
| 5. Yield Pattern of o-Ethylphenol Thermolysis in Dodecane | 143 |
| 6. Gas Analysis. | 151 |
| 7. Mutual Influence of o-Ethylphenol and Dodecane during Thermolysis | 153 |
| E. Thermolytic Reactions of Para and Meta-Ethylphenols in Solvent. | 154 |
| 1. Thermolysis of p-Ethylphenol in Dodecane. | 160 |
| 2. Thermolysis of m-Ethylphenol in Dodecane. | 160 |
| 3. Comparison of Thermolytic Behaviors of the Three Isomeric Ethylphenols | 161 |

| Chapter | Page |
|--|------|
| VI. CONCLUSIONS AND RECOMMENDATIONS. | 166 |
| BIBLIOGRAPHY. | 171 |
| APPENDICES. | 183 |
| A. EXPERIMENTAL PROCEDURE. | 183 |
| A. System Purging and Cleaning | 184 |
| B. Feed Injection. | 184 |
| C. Product Sampling. | 186 |
| D. Reaction Quenching. | 187 |
| E. Product Analysis. | 187 |
| B. TABULATION OF EXPERIMENTAL DATA | 198 |
| C. ESTIMATION OF DATA ACCURACY | 236 |
| D. TABULATION OF CALCULATED DATA | 241 |

LIST OF TABLES

| Table | Page |
|---|------|
| I. Oxygen Content of Some Coal-Derived Liquids. | 5 |
| II. Oxygen Compounds in Coal-Derived Liquids | 9 |
| III. Uncatalyzed Pyrolysis of Phenols in The Absence of Hydrogen Donors and Molecular Hydrogen | 19 |
| IV. Products of Pyrolysis of SRC-II Recycle Solvent. | 25 |
| V. Reactions of Oxygen Compounds with Donor Solvents. | 27 |
| VI. Kinetics of Disappearance of Oxygen Compounds Heated with Excess Tetralin. | 32 |
| VII. Reaction Run List. | 53 |
| VIII. Comparison of Product Yields from Thermal Cracking of Hexadecane and Dodecane | 105 |
| IX. Experimental and Theoretical Products from Dodecane Thermolysis. | 119 |
| X. Products from o-Ethylphenol Thermolysis. | 127 |
| XI. First Order Rate Coefficients of o-Ethylphenol Thermolysis. | 139 |
| XII. First Order Rate Coefficients of Dodecane Conversion | 144 |
| XIII. Products from o-Ethylphenol Thermolysis in Dodecane. | 147 |
| XIV. First Order Rate Coefficients for The Thermolysis of Isomeric Ethylphenols in Dodecane. | 162 |
| XV. Relative Molar Response Factors of Light Hydrocarbons. . . . | 191 |
| XVI. Relative Weight Response Factors of Hydrocarbons | 192 |
| XVII. Relative Weight Response Factors of Oxygen Compounds | 193 |
| XVIII. Material Balances of Reaction Runs | 199 |
| XIX. Thermal Reactivity of Dodecane (Run 2) | 200 |

| Table | Page |
|---|------|
| XX. Thermal Reactivity of Dodecane (Run 1) | 201 |
| XXI. Thermal Reactivity of Dodecane (Run 7) | 202 |
| XXII. Product Distribution of Dodecane Thermolysis (Run 12) . . | 203 |
| XXIII. Product Distribution of Dodecane Thermolysis (Run 13) . . | 204 |
| XXIV. Product Distribution of Dodecane Thermolysis (Run 14) . . | 205 |
| XXV. Gas Analysis of Dodecane Thermolysis. | 206 |
| XXVI. Product Distribution of o-Ethylphenol Thermolysis (Run 15). | 207 |
| XXVII. Product Distribution of o-Ethylphenol Thermolysis (Run 16). | 208 |
| XXVIII. Gas Analysis for o-Ethylphenol Thermolysis. | 209 |
| XXIX. Analysis of Gas Condensates from o-Ethylphenol Thermolysis | 210 |
| XXX. Product Distribution of o-Ethylphenol Thermolysis in Dodecane (Run 3) | 211 |
| XXXI. Product Distribution of o-Ethylphenol Thermolysis in Dodecane (Run 6) | 212 |
| XXXII. Product Distribution of o-Ethylphenol Thermolysis in Dodecane (Run 8) | 214 |
| XXXIII. Product Distribution of o-Ethylphenol Thermolysis in Dodecane (Run 4) | 216 |
| XXXIV. Product Distribution of o-Ethylphenol Thermolysis in Dodecane (Run 5) | 218 |
| XXXV. Product Distribution of o-Ethylphenol Thermolysis in Dodecane (Run 9) | 220 |
| XXXVI. Product Distribution of o-Ethylphenol Thermolysis in Dodecane (Run 10). | 222 |
| XXXVII. Product Distribution of o-Ethylphenol Thermolysis in Dodecane (Run 21). | 224 |
| XXXVIII. Product Distribution of o-Ethylphenol Thermolysis in Dodecane (Run 20). | 226 |
| XXXIX. Gas Analysis for o-Ethylphenol Thermolysis in Dodecane | 228 |

| Table | Page |
|---|------|
| XL. Product Distribution of p-Ethylphenol Thermolysis in Dodecane (Run 17) | 229 |
| XLI. Product Distribution of m-Ethylphenol Thermolysis in Dodecane (Run 18) | 231 |
| XLII. Product Distribution of m-Ethylphenol Thermolysis in Dodecane (Run 19) | 233 |
| XLIII. Gas Analysis for p- and m-Ethylphenols Thermolyses in Dodecane | 235 |
| XLIV. Error Estimation of GC Analysis | 237 |
| XLV. Regression Analysis of Dodecane Conversion Data | 242 |
| XLVI. Test of Difference Between Run 12 and Run 14. | 244 |
| XLVII. Regression Analysis of o-Ethylphenol Conversion Data. | 245 |
| XLVIII. Test of Difference Between Run 15 and Run 16. | 246 |
| XLIX. Regression Analysis of o-Ethylphenol-in-Dodecane Conversion Data | 247 |

LIST OF FIGURES

| Figure | Page |
|---|------|
| 1. Model Average Structures of Fractions of a Supercritical-Gas Extract of Coal | 7 |
| 2. Computed Equilibria in Reduction of Oxygen Compounds by Molecular Hydrogen | 17 |
| 3. Computed Equilibria in Reduction of Oxygen Compounds by Tetralin | 17 |
| 4. Batch Autoclave System. | 48 |
| 5. Reactor System. | 49 |
| 6. Material Balance of Experimental Runs | 55 |
| 7. Dodecane Conversion under Various Conditions. | 58 |
| 8. Product Distribution of Dodecane Thermolysis (Run 12) | 59 |
| 9. Production Distribution of Dodecane Thermolysis (Run 13). | 60 |
| 10. Production Distribution of Dodecane Thermolysis (Run 14). | 61 |
| 11. Products from Dodecane Thermolysis in Different Environments. | 62 |
| 12. Paraffins and Olefins from Dodecane Thermolysis (1) | 64 |
| 13. Paraffins and Olefins from Dodecane Thermolysis (2) | 65 |
| 14. Paraffins and Olefins from Dodecane Thermolysis (3) | 66 |
| 15. Gas Analysis for Dodecane Thermolysis (Runs 12 and 14). | 69 |
| 16. Gas Analysis for Dodecane Thermolysis (Run 13). | 70 |
| 17. Product Distribution of o-Ethylphenol Thermolysis (Run 15). | 71 |
| 18. Product Distribution of o-Ethylphenol Thermolysis (Run 16). | 72 |

| Figure | Page |
|---|------|
| 19. Gas Analysis for o-Ethylphenol Thermolysis. | 73 |
| 20. Typical Chromatogram for Liquid Samples from o-Ethylphenol Thermolysis | 74 |
| 21. Product Distribution of o-Ethylphenol Thermolysis in Dodecane (Run 3). | 76 |
| 22. Product Distribution of o-Ethylphenol Thermolysis in Dodecane (Run 6). | 77 |
| 23. Typical Chromatogram for Liquid Samples from o-Ethylphenol Thermolysis in Dodecane | 78 |
| 24. Product Distribution of o-Ethylphenol Thermolysis in Dodecane (Run 8). | 81 |
| 25. Product Distribution of o-Ethylphenol Thermolysis in Dodecane (Run 4) | 82 |
| 26. Product Distribution of o-Ethylphenol Thermolysis in Dodecane (Run 5) | 83 |
| 27. Product Distribution of o-Ethylphenol Thermolysis in Dodecane (Run 9). | 84 |
| 28. Product Distribution of o-Ethylphenol Thermolysis in Dodecane (Run 10) | 86 |
| 29. Product Distribution of o-Ethylphenol Thermolysis in Dodecane (Run 21) | 87 |
| 30. Product Distribution of o-Ethylphenol Thermolysis in Dodecane (Run 20) | 88 |
| 31. Product Distribution of p-Ethylphenol Thermolysis in Dodecane (Run 17) | 89 |
| 32. Product Distribution of m-Ethylphenol Thermolysis in Dodecane (Run 18) | 90 |
| 33. Product Distribution of m-Ethylphenol Thermolysis in Dodecane (Run 19) | 91 |
| 34. Regression Analysis of o-Ethylphenol Conversion Data. | 124 |
| 35. Reaction Scheme of o-Ethylphenol Thermolysis. | 135 |
| 36. Proposed Reaction Network for o-Ethylphenol Thermolysis | 136 |
| 37. Temperature Effect on o-Ethylphenol Thermolysis in Dodecane . . | 138 |

| Figure | Page |
|--|------|
| 38. Arrhenius Plot of o-Ethylphenol Thermolysis in Dodecane. . . . | 140 |
| 39. Hydrogen Effect on o-Ethylphenol Thermolysis | 142 |
| 40. Arrhenius Plot of Dodecane Thermolysis | 145 |
| 41. Molar Ratios $(C_2+C_2^=)/C_1$ and Phenol/Cresols in o-Ethylphenol Thermolysis Products | 152 |
| 42. Mutual Influence of o-Ethylphenol and Dodecane Thermolysis (1). | 155 |
| 43. Mutual Influence of o-Ethylphenol and Dodecane Thermolysis (2). | 156 |
| 44. Mutual Influence of o-Ethylphenol and Dodecane Thermolysis (3). | 157 |
| 45. Mutual Influence of o-Ethylphenol and Dodecane Thermolysis (4). | 158 |
| 46. Mutual Influence of o-Ethylphenol and Dodecane Thermolysis (5). | 159 |
| 47. Comparison of Thermolytic Reaction Products of Isomeric Ethylphenols (1) | 163 |
| 48. Comparison of Thermolytic Reaction Products of Isomeric Ethylphenols (2) | 164 |
| 49. Detector Response for Ethane | 194 |
| 50. Detector Response for Dodecane | 195 |
| 51. Detector Response for o-Ethylphenol. | 196 |
| 52. Detector Response for p- and m-Ethylphenols. | 197 |

CHAPTER I

INTRODUCTION

This study encompasses an investigation of thermal reactivities of isomeric ethylphenols, which are representatives of the oxygen-containing compounds in coal-derived liquids, and their solution in dodecane, a convenient carrier solvent.

Despite the fact that oxygen-containing compounds are much more abundant in coal-derived liquids than nitrogen- and sulfur-containing species, the oxygen compounds have received little attention compared to their nitrogen and sulfur counterparts. Only very recently have the oxygen species and their reactions received concerted investigation. This lack of attention is not a result of, nor should one infer, low importance of such species in coal conversion and coal liquid upgrading processes.

Although oxygen compounds in coal-derived liquids do not have the same adverse effects on processes and products that nitrogen compounds (poisoning of catalysts) and sulfur compounds (catalysts poisoning, air pollution) do, they promote coking on thermal treatment, and much of the hydrogen consumed during upgrading is expended on oxygen removal. The rapid catalyst deterioration and tremendous hydrogen consumption are two main factors leading to high operating costs of coal oil upgrading.

Oxygen-containing species were considered to be more easily removed than those of other heteroatoms, nevertheless, ortho alkylphenols and

aromatic ethers are in fact much more difficult to eliminate than sulfur compounds. The same hydrogenation used to remove nitrogen and sulfur compounds involves the oxygen compounds also, hence all three must often be discussed together.

Phenols constitute the major part of the oxygen compounds in coal-derived liquids. A thorough understanding of their behavior under conditions of commercial interest would provide useful knowledge for upgrading technology. On this realization, the present research was proposed and performed.

Of the three isomeric ethylphenols, in particular, the ortho isomer, either in pure state, or in dodecane solution, was studied in detail.

In order to understand the mutual effects, if they exist, of the phenols and the solvent, thermolysis of only dodecane was first investigated.

CHAPTER II

OXYGEN COMPOUNDS IN COAL-DERIVED LIQUIDS

A comprehensive review of oxygen compounds found in coal-derived liquids is presented here with some discussion of published data.

A. Oxygen in Coal-Derived Liquids

Coal-derived liquids can be divided into two categories:¹

1. Those obtained in relatively low yields by solvent extraction at low temperatures. They are substances removed mainly by dissolution of soluble coal constituents.

2. Those obtained by a higher-temperature depolymerization of coal. Higher liquid yields are achieved by means of a number of processes in commercial application: solvent refining, catalytic hydrogenation, etc.

The latter usually have lower H/C and O/C ratios than the corresponding extract fractions, and the H/C ratio for the residual coal is lower than that of the liquid for either type. The hydrogen and nitrogen contents are little changed (Mayo and Kirshen, 1978).

¹In using the term coal-derived liquids, within the context of this chapter, products of coal pyrolysis and liquids indirectly produced from coal by conversion to synthesis gas and Fischer-Tropsch methods are excluded.

A.1. Oxygen Content of Coal-Derived Liquids

Table I shows the oxygen content for some coal-derived liquids. The oxygen levels roughly parallel the O/C ratios of the liquids; this is of course because the carbon content does not vary much. In coal-liquid fractions, the O/C ratio increases with molecular weight (Yokoyama et al., 1983); thus oxygen levels were 1.10-1.51 wt.% in a fraction boiling at 400-544 K but 3.20-3.99 wt.% in that boiling above 544 K (Bertolacini et al., 1979). A product from the Synthoil direct hydrogenation process was found to have most of its oxygen in aromatic compounds containing 1-4 rings (1.5-3.5 wt.% per type) (Aczel et al., 1978).

Possible component structures of coal-derived liquid fractions have been proposed; model average structures of oxygen-containing fractions of a supercritical-gas extract of coal are shown in Figure 1. The pictures give some idea of how these oxygen functional groups are situated, but the location of functional groups and side chains on the structures are hypothetical, indeed. For describing coal-derived liquids, average structural models become even less useful as the sample becomes more complicated. For a better understanding of the oxygen chemistry of coal, detailed information on the oxygen-containing compounds of coal liquids seems necessary.

A.2. Oxygen Compounds and Functions in Coal-Derived Liquids

Since isolation of pure compounds from coal liquids is extremely difficult, other approaches have been developed and used by most

TABLE I
OXYGEN CONTENT OF SOME COAL-DERIVED LIQUIDS

| Coal used; liquefaction process used; fraction (if any) used | Oxygen wt% | Reference |
|---|---------------|-------------------------------------|
| Alabama; H-Coal and SRC | 4.1-5.0 | Chao et al. (1980) |
| Various Coals and Lignites, SRC | 2.1-7.7 | Baltisberger et al. (1978, 1979) |
| West Virginia; SRC-II; original | 3.29 | Satterfield et (1980) |
| upgraded with H ₂ | 0.3-2.0 | |
| SRC filtrates, original | 4.0 | Givens et al. (1979) |
| upgraded with H ₂ | 1.4-2.9 | |
| Kentucky and Wyodak; SRC | 3.4-6.7 | Whitehurst et al. (1979) |
| Kentucky and Wyodak; SRC fractions | 1.06-11.75 | Whitehurst et al. (1980) |
| Various; H-Coal, COED, SRC, Synthoil | 0.84-7.08 | Schwager and Yen, (1978) |
| Illinois No. 6; SRC; heavy distillate | 1.8 | Thomas and Bickel (1980) |
| Direct Conversion Process, PETC; asphaltenes, C ₆ H ₆ eluate | 2.95-3.09 | Bockrath and Noceti (1979) |
| tetrahydrofuran eluate | 3.90-7.03 | |
| Wyoming subbituminous; H ₂ /anthracene oil without catalyst | 1.8 | Ruberto et al. (1977) |
| with catalyst | 1.25 | |
| Various; catalytic hydroliquefaction; original | 0.59-2.09 | Stein et al., (1978); |
| after upgrading | 0.04-0.61 | Sturm et al. (1980) |

TABLE I (continued)

| Coal used; liquefaction process used; fraction (if any) used | Oxygen wt.% | Reference |
|---|----------------|-------------------------------|
| Illinois No. 6; hydroliquefaction | 0.97-1.44 | Bertolacini et al. (1979) |
| High-S West Virginia; Synthoil | 3.9 | Cogswell and Latham (1978) |
| Pittsburgh; Synthoil; asphaltenes | 3.05-5.45 | Bockrath et al. (1978) |
| Asphaltenes | 3.93 | Schwager and Yen, (1978) |
| German bituminous; hydrogenated; light oil | 3.5 | Romey et al. (1981) |
| middle oil | 3.0 | |

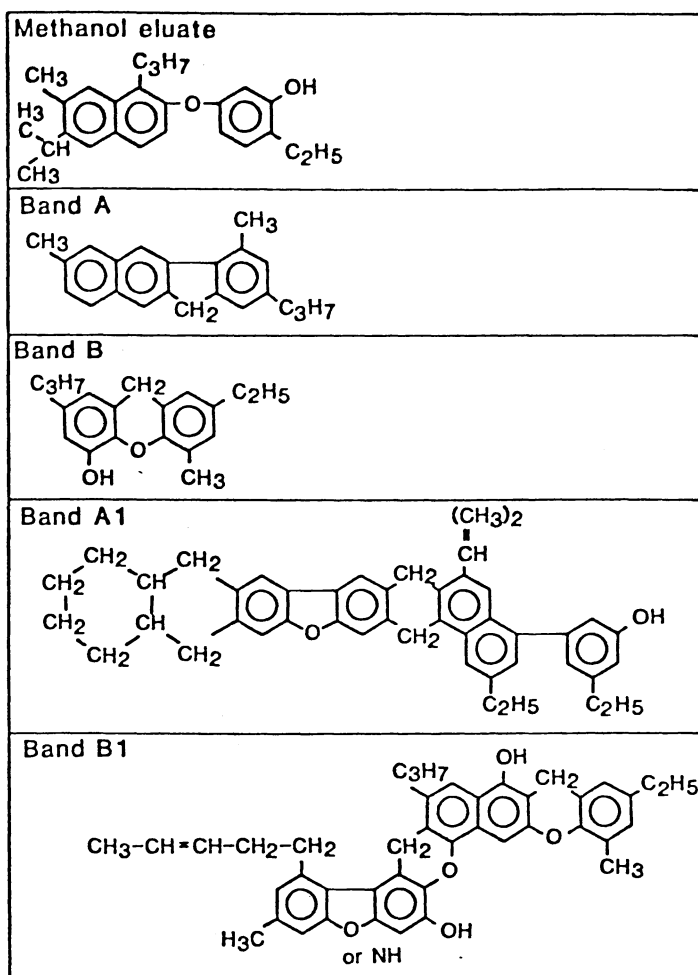

Figure 1. Model Average Structures of Fractions of a Supercritical-gas Extract of Coal. Bands A and B - GPC subfractions of petroleum-ether solubles. Bands A1 and B1 - GPC subfractions of petroleum-ether-insoluble/benzene-soluble fraction. (Bartle et al., 1975)

researchers. Functional group analysis can provide information on types of compounds present, while instrumental methods can also sometimes permit the identification and even quantitative determination of compounds in a coal liquid without isolating them. Practically the whole arsenal of modern techniques for fractionation and structural analysis has been applied: liquid-liquid extractions, chromatography of all types, IR, NMR, and mass spectrometry. A large amount of recent work as it pertains to oxygen compounds is summarized in Table II. No attempt has been made to search the older literature, mostly German.

As seen from Table II, phenols completely dominate the types of compounds identified in products of coal hydroliquefaction, although the levels present vary widely. Weinberg and Yen (1980) believe that molecules like those found in liquefaction products already exist in the parent coal and thus hydrogenation products reflect the structure of the starting material. Evidence that phenols are formed in coal hydroliquefaction by reductive cleavage of ethers has been provided by Wachowska and Pawlak (1977) and by Aczel et al. (1978). The covalent bond cleavage also leads to some loss of hydrogen and more oxygen (Mayo, 1977).

Products of extraction of coal with supercritical toluene would not at first appear to be directly comparable with those of either hydroliquefaction or mild solvent extraction, since liquefaction is conducted under reducing conditions, while the temperature required to produce supercritical toluene must break some covalent bonds. Nevertheless, from the relatively low levels of phenols in the products, supercritical toluene extraction does not give results much different from extraction with low-boiling solvents at 323 K. Extraction with supercritical com-

TABLE II
OXYGEN COMPOUNDS IN COAL-DERIVED LIQUIDS

| Coal used; process used; fraction (if any) used | Types of compounds characterized (wt.%) | Reference |
|--|---|----------------------------|
| A. Liquefaction processes | | |
| Illinois No. 6; H-Coal cut | Phenols 17% | Becker et al. (no date) |
| H-Coal; still bottoms | Phenols contg. N and S; 17% overall, 20% in asphaltenes, 25% in pre-asphaltenes | Smith et al. (1979) |
| Eastern U. S. coals; SRC-II; cut boiling range 328-522 K | Alkylphenols; 13 identified | Fleming and Talbot (1982) |
| Eastern bituminous; SRC-II; cut boiling range 328-533 K | Phenols 29% | Singerman (1981) |
| SRC-II; middle distillate | 29 alkylphenols, indanols, naphthols, phenylphenols | White and Li (1982) |
| West Virginia; SRC-II; heavy distillate | Indenols, phenylphenols, fluorenols, and naphthylphenols | Later et al. (1981) |
| Powhatan No. 5; SRC-II; heavy distillate | Phenols 2.3%, stronger acids 0.2% | Petrakis et al. (1983 a,b) |
| Wodak; SRC; fractions | Phenols: 3.9% in oils, 23.2% in preasphaltenes, 34.1% in whole liquid | Boduszynski et al. (1982) |
| North Dakota lignite; SRC and CO/steam; residues | Content of acidic compounds increased with MW | Farnum and Knudsen (1978) |
| Mostly SRC; residues | Phenols 3.2-4.3% | Schiller et al. (1977) |

TABLE II (continued)

| Coal used; process used; fraction (if any) used | Types of compounds characterized (wt.%) | Reference |
|---|---|---|
| Illinois No. 6; EDS; cut boiling range 343-473 K | Phenols 10% | Epperly (1979) |
| Various | Phenols and benzo- furans | Schiller (1977) |
| Various | Many phenols | Aczel and Lumpkin (1979) |
| SRC-I and H-Coal; recycle solvents | Alkylphenols, dibenzo- furans; Ph ₂ O probably an artifact | Burke et al. (1981) |
| Various; recycle solvents | Alkylphenols | Schabron et al. (1979); Hurtubise et al. (1981) |
| West Virginia; recycle solvent | Hydroaromatic phenols (no single rings); 2.2-7.9% phenolic OH | Whitehurst et al. (1979) |
| Various; 9% asphaltenes to 39% asphaltenes | Phenols 1%, ethers 1.2% Phenols 2%, ethers 1.8% | Bockrath and Schweighardt (1979) |
| Various; asphaltenes | 2-6% oxygen present as phenols and ethers | Bockrath and Schweighardt, (1981) |
| Asphaltenes: Synthoil and EDS | Phenols 1.98-2.93%, ethers and furans 2.6-6.7% | Aczel et al. (1981) |
| Synthoil, FMC-COED, SRC; asphaltenes and preasphaltenes | Phenols, diaryl ethers, furans | Baltisberger et al. (1981b) |
| Synthoil, H-Coal, COED, SRC; asphaltenes | Phenols 2.6-5.88%, 59-83% of total oxygen | Schwager and Yen (1979) |

TABLE II (continued)

| Coal used; process used; fraction (if any) used | Types of compounds characterized (wt.%) | Reference |
|---|--|---|
| Various; asphaltenes | Phenols, some hetero- cyclics; av. MW 400-500; no more than 4 condensed rings | Bodzek et al. (1979) |
| Colorado; COED; oil asphaltenes | Phenols 20%: with one O, C ₆ -C ₂₅ ; with 2 O, C ₆ -C ₁₈ ; neutrals hetero-O, mostly benzofurans Phenols about 10%: with 1 O, C ₁₇ -C ₂₇ ; with 2 O, C ₆ -C ₂₈ ; Neutrals as for oil | Scheppele et al. (1981) |
| Pittsburgh; asphaltenes | Phenols 10% | Bockrath et al. (1978) |
| Japanese coal; hydrogenated; asphaltenes | Phenols 3.3%; other oxygen compounds 4.9% | Takegami et al. (1963) |
| Pittsburgh; hydrogenated; asphaltenes | Alkylphenols, phenyl- phenols, polynuclear phenols | Husack and Golombic (1951) |
| Pittsburgh; Consol Synthetic Fuel | Phenols, dibenzofurans (4%, building up to 11%) | Kleinpeter et al. (1979) |
| Pittsburgh; Synthoil | Phenols 6.3%; essen- tially no carbonyl compounds | Schweighardt et al. (1977) |
| West Virginia; Synthoil | Phenols 25%, at least 15% aromatic ethers | Cogswell and Latham (1978) |
| North Dakota lignite; CO/H ₂ process; light oil | Phenols 25%, nearly all single-ring | Farnum et al. (1980); Farnum and Farnum (1982) |
| North Dakota lignite; SRL; preasphaltenes | Phenolic OH 1.0-3.3%, ethers 2.2-5.3% | Baltisberger et al. (1981a) |

TABLE II (continued)

| Coal used; process used; fraction (if any) used | Types of compounds characterized (wt.%) | Reference |
|---|---|---|
| Low-rank coal; CO/steam process | Alkylphenols, indanols, indenols, naphthols | Schiller and Mathiason (1977) |
| West Virginia coal and North Dakota lignite; hydrogenated | Alkylphenols, indanols, naphthols | Philip et al. (1980); Zingaro et al. (1981) |
| Texas lignite; hydrogenated | Alkylphenols, ketones, furans | Philip and Anthony (1977, 1978a,b, 1982) |
| German coal; hydrogenated; light and middle oils | Phenol, alkylphenols, naphthols | Liphard et al. (1981) |
| Assam coal; hydrogenated; cut boiling up to 543 K/75 mmHg | Phenols 40% | Tiwari et al. (1978) |
| Wyoming; hydrogenated in anthracene oil | Phenols 5.04%, stronger acids 1.31%; phenols about half the total oxygen | Ruberto et al. (1977) |
| Waste waters from coal liquefaction processes | About 40 relatively volatile compounds, mostly phenols | White and Schmidt (1978) |
| B. <u>Extraction processes</u> | | |
| English coals; supercritical PhMe extract | Phenolic OH 4.8%, 51% of all oxygen | Bartle et al. (1975) |
| English coals; supercritical PhMe extract; oil | OH 2.2-6.2%, ethers 0.9-2.6% | Bartle et al. (1979) |
| asphaltenes | OH 3.0-6.2%, ethers 1.2-2.8% | |
| Turkish lignites; super- critical PhMe extracts | 28 oxygen compounds, mostly phenols; some furans and ketones | Tugrul and Olcay (1978) |

TABLE II (continued)

| Coal used; process used; fraction (if any) used | Types of compounds characterized (wt.%) | Reference |
|--|--|-------------------------|
| Asphaltenes from super-critical PhMe extract: coal | OH 3.7-7.2%, aliphatic ethers <0.5%, aromatic ethers 1.0-2.9%, carbonyls <0.5-2.5% | Snape et al. (1982) |
| lignite | OH 3.4-4.2%, aliphatic ethers 0.5%, aromatic ethers 3.2-3.7%, carbonyls 7.0% | |
| Pennsylvania coal; asphaltenes from extract | Phenols 1.58%, RCOOH 0.2%, ethers and furans 4.2% | Aczel et al. (1981) |
| British coal (82.4% C, phenolic OH 2.7 wt.%, 31% of total O); Parallel extractions at 323 K for 4 h (solvent and yield, wt.% shown) | Phenolic OH, wt.% | Maher and O'Shea (1967) |
| Benzene (0.5) | 3.0 | |
| Mixed xylenes (1.0) | 2.9 | |
| Chloroform (1.1) | 6.0 | |
| Isopropyl alcohol (1.5) | 3.7 | |
| Acetone (1.6) | 3.0 | |
| Diethylamine (3.5) | 2.9 | |
| Pyridine (13) | 4.5 | |
| Ethanolamine (14) | 4.3 | |
| Dimethylformamide (20) | 2.2 | |
| Pittsburgh seam (HVAB) coal; successive extractions with pyridine | Phenols in extracts, wt.% | Friedel et al. (1968) |
| 1st extract, 0.08 h (yield 2.4 %) | Phenols, 10.8, indanols 1.8 | |
| 2nd extract, 0.5 h (yield 4.6%) | Phenols, 3.1, dihydric and/or alkoxyphenols 0.5, indenenes and naphthols 1.1, indanols 2.2 | |
| 3rd extract, 17 h (yield 12.3%) | Phenols 3.2, dihydric and/or alkoxyphenols 0.5, indenenes and naphthols 0.7, indanols 2.1 | |

pounds of other types, such as CO_2 and SO_2 , would be interesting but probably not much different again.

The limited data in Table II on low-temperature extracts from coal show that product yields and phenol contents vary with solvent and extraction time, but qualitatively the extracts are alike. In most cases the sum of phenolic-group contents of extracts and residues is higher than that of the original coal, showing liberation of such groups even under mild conditions, probably by depolymerization (Maher and O'Shea, 1967).

Solvent extraction is believed to be, in principle, a substitution reaction. Extractable substances, bound to the coal macromolecular network by electron-donor-acceptor bonds, are displaced by solvent molecules (Gutmann, 1978; Marzec et al., 1979; Bodzek and Marzec, 1981). In contrast, liquefaction processes consist mostly of conversion of insoluble coal to pyridine-soluble, toluene-insoluble materials (Mayo, 1977). In coal structures covalent bonds linking aliphatic carbon to oxygen will all be ruptured before temperatures reach 673 K, and those binding aromatic carbon to oxygen will be considerably decomposed at 723 K (Kamiya et al., 1979). Thus high-conversion hydroliquefaction removed a substantial fraction of the oxygen in coal, some as CO_2 but mostly as H_2O .

To summarize: the oxygen content of crude coal-derived liquids ranges from 0.6 to 5.7 wt.%, much lower than that of bituminous coal or lignite. These liquids are very complicated mixtures of numerous hydrocarbons and heteroatom compounds, differing greatly in molecular weights and chemical structures. Generally, for coal liquefaction products, over 40% of the total coal liquids are oxygen compounds; most of them

(over 30% of the liquid) are phenolic. About 10% is of benzofuran or dibenzofuran types. Carboxylic acids are present in minor amounts and carbonyl compounds have been found in asphaltene fractions. No alcoholic groups or purely aliphatic ether groups have been reported.

B. Thermal Reactions of Oxygen Compounds Related to Coals and Coal Liquids

B.1. Thermodynamic Considerations

An important objective of coal liquid processing is to remove the heteroatoms, which requires rupturing C-S, C-N, and C-O bonds. The breaking of these bonds may determine the conversion and reaction rate obtainable in coal liquefaction and coal oil upgrading.

Purely aliphatic compounds can hardly survive the thermal or catalytic treatments used. In the other hand, homo- and heterocyclic aromatics are known for their stability. Ring opening is essential for the removal of any heterocyclics, with or without preliminary ring hydrogenation. The usual routes for hydrodesulfurization (HDS), hydrodenitrogenation (HDN), and hydrodeoxygenation (HDO) of such molecules are shown as follows (Furimsky, 1979):

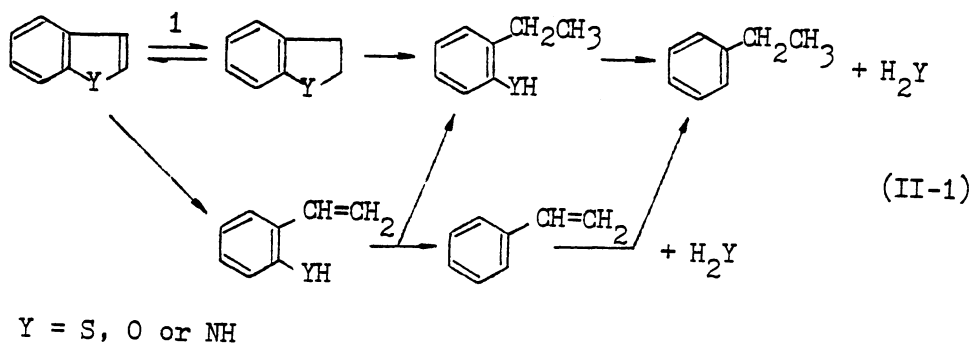

In the above scheme, step 1 is equilibrium hydrogenation of the heteroatom-containing ring. Ring saturation is important for nitrogen heterocyclics while experimental evidence indicates that for the sulfur-containing rings both routes are possible. Rollman (1977) considered that ring hydrogenation is necessary for furan HDO.

The two kinds of C-Y bonds in Eq. II-1 above in the intermediates have different strengths. The hydrogenolysis of the saturated heteroring will occur predominantly at the weaker C-Y bond, and form alkylphenols, -anilines, and -thiophenols. In these compounds, the C-Y bond strength decreases in the order C-O > C-N > C-S, suggesting that the thiophenols will be least resistant and phenols most resistant to further hydrogenolysis.

For larger molecules, such as dibenzothiophene, dibenzofuran, and carbazole, the ring is opened through C-Y bond scission either directly or after the bond is weakened by saturation of the attached aromatic ring (Qader et al., 1968). The relative ease of hetero ring opening increases from oxygen through nitrogen to sulfur (Cottrell, 1958).

Messenger and Attar (1979) examined the chemistry and thermodynamics of reactions of functional groups in coal during liquefaction, and their computed results are consistent with experimental data on coal and model compounds. They differentiate HDO reactions into three classes: (1) removal of ether oxygen, which produces compounds of considerably smaller molecular weight than the parent material, (2) removal of hydroxy group, which leads to a small reduction in molecular weight but a larger one in functionality, and (3) ring opening, as in reduction of alkylfurans to alkanes. Figures 2 and 3 show the variation in calculated equilibrium constants with temperature for reactions

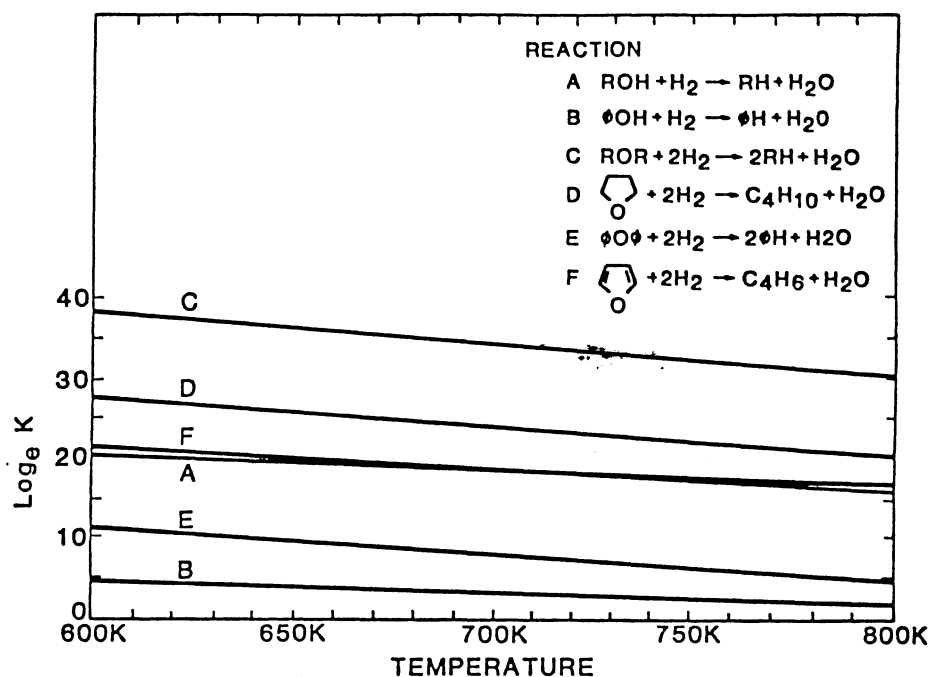

Figure 2. Computed Equilibria in Reduction of Oxygen Compounds by H_2 (Messenger & Attar, 1979)

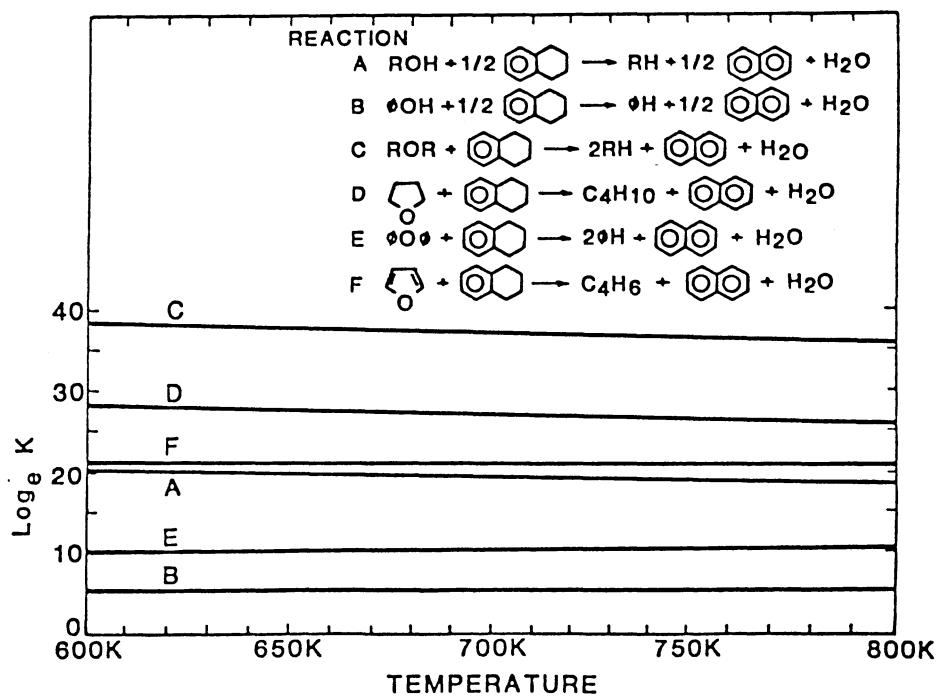

Figure 3. Computed Equilibria in Reduction of Oxygen Compounds by Tetralin (Messenger & Attar, 1979)

involving elimination of oxygen-containing groups in hydrogen and in tetralin, respectively. The figures show that such removal is much more favored for alcohols, aliphatic ethers, furans, and tetrahydrofurans than for phenols and diaryl ethers. Since the equilibrium constants for reactions with hydrogen are decreased more by temperature rise, tetralin should be a better deoxygenation agent (Messenger and Attar, 1979). One must recognize, however, that reaction rates, rather than thermodynamics, usually determine results. Benzofurans and dibenzofurans are most like aromatic ethers, and thus hard to deoxygenate.

The same calculations (Messenger and Attar, 1979) indicate that sulfur would be much easier to eliminate than oxygen, which agrees with experience on model compounds. This is because: 1) the C-O bond is much stronger than the C-S bond, 2) the O-H bond is much stronger than the S-H bond, and 3) the sulfur n-electrons can resonate with groups that contain π bonds, such as double bonds and aromatic nuclei, while oxygen electrons do this much less. Thus heteroatom removal from oxygen compounds should be more difficult than from their sulfur counterparts.

B.2. Thermal Reactions of Model Oxygen Compounds in the Absence of Hydrogen Donors and Molecular Hydrogen

Mononuclear phenols are relatively resistant to decomposition by heat (Whitehurst et al., 1979), Table III lists pyrolysis temperatures and products formed from such phenols. From the table most phenols, especially the cresols, react by two competitive pathways, even under mild conditions. For example, o-cresol yields mainly benzene, toluene, and phenol. The formation of the hydrocarbons has been suggested to

TABLE III
 UNCATALYZED PYROLYSIS OF PHENOLS IN THE ABSENCE
 OF HYDROGEN DONORS AND MOLECULAR HYDROGEN

| Phenol | Temperature (K); time (s) | Main products (gases ignored) | Reference |
|--|---------------------------|--|---|
| PhOH | 1053-1103; 1.4-2.5 | C ₆ H ₆ , PhMe, C ₁₀ H ₈ , indene, dibenzofuran | Cypres and Bettens (1974, 1975b), Braekman-Danheux and Heyvert (1972) |
| o-, m- and o-Cresols | 873-1123; 0.5-40 | C ₆ H ₆ , PhMe, PhOH | Jones and Neuworth (1952, 1953); Wells and Long (1962); Cypres and Lejeune (1965); Kawase et al. (1970); Cypres and Bettens (1975a); Braekman- Danheux et al. (1977); Platonov et al. (1981a) |
| Xylenols | 923-1123; 2 | As for o-cresol, plus xylenes and cresols | Cypres et al. (1970); Braekman-Danheux et al. (1977); Platonov et al. (1982, 1983) |
| (3,5-t-Bu ₂ -4-HO-C ₆ H ₂) ₂ CH ₂ | | p-t-BuC ₆ H ₄ OH, Ph ₂ O | Larsen and Lee (1983) |
| 4-(1-C ₁₀ H ₇ CH ₂)-3,5-t- BuC ₆ H ₂ OH | | C ₁₀ H ₈ , 2,6-t-Bu ₂ -C ₆ H ₃ OH | Larsen and Lee (1983) |

TABLE III (continued)

| Phenol | Temperature (K); time (s) | Main products (gases ignored) | Reference |
|---|---------------------------|---|--|
| Benzenediols | | Arenes, PhOH, products via quinones and loss of CO | Sakai and Hattori (1976b), Sakai et al. (1980b) |
| o-MeOC ₆ H ₄ OH | | o-C ₆ H ₄ (OH) ₂ , PhOH, o-Me C ₆ H ₄ OH, methylated catechols and guiacols | Ceylan and Bredenberg (1982) |
| o-PhCH ₂ OC ₆ H ₄ OH | | o-PhCH ₂ C ₆ H ₄ OH, p-PhCH ₂ C ₆ H ₄ OH, 9-Ph-xanthene | Larsen and Lee (1983) |
| p-PhCH ₂ OC ₆ H ₄ OH | | o-PhCH ₂ C ₆ H ₄ OH, p-PhCH ₂ C ₆ H ₄ OH, 9-(0-HOC ₆ H ₄)-xanthene | Larsen and Lee (1983) |
| 1-C ₁₀ H ₇ OH | | 2,2'-Binaphthalene-1,1'-diol, thence the dinaphthofuran, 1-tetralone, C ₁₀ H ₈ | Merz and Weith (1881); Poutsma (1980); Poutsma and Dyer (1981, 1982) |
| 1-C ₁₀ H ₇ OH | | About 50% indene and 50% C ₁₀ H ₈ | Cypres (1981); Bredael et al. (1983) |
| 2-C ₁₀ H ₇ OH | | Binaphthalenediols, dinaphthofurans, 2-tetralone | Poutsma and Dyer (1981, 1982) |
| 2-C ₁₀ H ₇ OH | | About 90% indene, 10% C ₁₀ H ₈ | Cypres (1981); Bredael et al (1983) |

TABLE III (continued)

| Phenol | Temperature (K); time (s) | Main products (gases ignored) | Reference |
|---|---------------------------|--|--------------------------------------|
| 1,2,3,4-H ₄ -1-C ₁₀ H ₇ OH | | Mainly initial dehydroxylation followed by dehydrogenation leading to C ₁₀ H ₈ | Cypres (1981); Bredael et al. (1983) |
| 5,6,7,8-H ₄ -1-C ₁₀ H ₇ OH | | Mainly initial dehydrogenation to 1-C ₁₀ H ₇ OH | Cypres (1981); Bredael et al. (1983) |
| H ₁₀ -1-C ₁₀ H ₇ OH | | About 90% to BTX, 10% indene | Cypres (1981) |
| H ₁₀ -1-C ₁₀ H ₇ OH | 923-1123; 0.6 | Large yields of gases and BTX (50 and 24 wt.% at 1073 K) | Bredael et al (1983) |
| 2,2'-Biphenol | | Dibenzofuran; kinetics studied | Pistrova and Kharlampovich (1974) |

proceed as shown (Cypres and Bettens, 1974, 1975a,b; Hedaya and Kent, 1971; Spielman and Cramers, 1972; Braekman-Danheux et al., 1977).

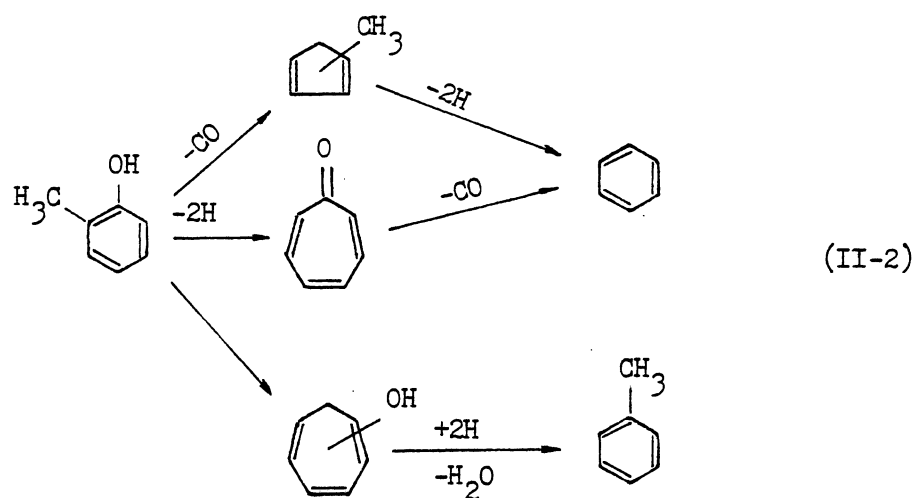

Similar mechanisms can be written for some other phenols.

Under severe conditions, 1073-1173 K, the order of stabilities of cresols was $m > p > o$. Isomerization predominated under mild conditions, and degradation under severe ones. About 20 arenes were identified among the products; phenol, cresols, and high-boiling phenols were also characterized.

The asphaltenes from the pyrolysis of cresols contained phenolic, quinonoid, and methoxy groups, and benzofuran structures; those from *o*-cresol also contained xanthene structures, and those from the *para* isomer, polyethers of type $(OC_6H_4CH_2)_n$ (Platonov et al., 1981a).

The overall pyrolysis of the cresols appeared to be a reaction of order 1.5, which confirms the complexity of the process. Formation of CO was first order, but with the activation energy for *m*-cresol double that for the others because the *m*-isomer cannot form a quinonoid

intermediate without prior demethylation (Platonov et al., 1981b; cf. Cypres and Betten, 1974). Similar diradical mechanisms were proposed for formation of naphthalene and fused-ring heterocyclic oxygen compounds from cresols.

Thermal decomposition of diaryl ethers is much more difficult than that of alkyl aryl ethers; thus diphenyl ether is well known as a heat-transfer agent, while benzylic ethers are particularly easy to decompose. Schlosberg and collaborators (1981a,b) considered the pyrolysis of dibenzyl ether to benzaldehyde and toluene to be a chain reaction, with PhCH_2 and $\text{PhCH}_2\text{OCHPh}$ as chain carriers. In other recent work, the primary decomposition of $\text{PhCH}_2\text{CH}_2\text{OPh}$ at 573-773 K was found to yield PhOH and $\text{PhCH}=\text{CH}_2$ (Klein and Virk, 1983). Tetrahydrofuran did not decompose at 603-703 K (Furimsky, 1983a). The very stable dibenzofuran underwent only 4.5% decomposition at 1103 K for 1.4 s; the main products were *o*- $\text{EtC}_6\text{H}_4\text{OH}$, PhMe , and indene (Braekman-Danheux and Heyvaert, 1972). The refractory behavior of diaryl ethers such as phenyl ether and of the cyclic diaryl ether, dibenzofuran as well as the relative instability of dibenzyl ether, were confirmed by Siskin and Aczel (1983). Dialkyl ethers lead mainly to hydrocarbon products and carbon monoxide but not to phenolic ones. Siskin and Aczel concluded that the only major types of ethers which cleave thermally to give phenols at 873 K are alkyl aryl ethers.

As examples of ester pyrolysis, $\text{PhCOOCH}_2\text{Ph}$ gave PhMe , PhCHO , PhCOOH , and $(\text{PhCO})_2$ (Hurd, 1929), while $\text{PhCH}_2\text{COOMe}$ gave PhMe and PhCHO (Risinger and Mach, 1962), and PhCOOPh , $\text{PhCOOCH}_2\text{Ph}$, $\text{PhCH}_2\text{COOPh}$, and $\text{PhCH}_2\text{COOCH}_2\text{Ph}$ gave similar but various products via radical mechanism (Aly et al, 1983).

Tetralone is pyrolyzed to $C_{10}H_8$ and water; a mechanism is given by Cronauer et al (1979). Quinones tend to decompose thermally by initial loss of CO to other cyclic ketones, and these to hydrocarbons; for example, both 9,10-phenanthraquinone (PQ) and 9,10-anthraquinone (AQ) at 823-873 K yield fluorenone and thence Ph_2 and C_6H_6 . However, the two processes differ in that fluorenone formation from AQ is accelerated by hydrogen, but that from PQ is not. Other para quinones, and some monoketones (anthrone, Ph_2CO , $PhCOMe$) behave like AQ, whereas other ortho quinones and some other carbonyl compounds are like PQ (Sakai and Hattori, 1976a; Sakai et al., 1980a,b,c; Sakai and Yamane, 1983).

As a brief summary, the order of pyrolytic stability is: acetals < aliphatic ethers < alkyl aryl ethers < phenols < diaryl ethers < quinones (Wolfs et al, 1959).

B.3. Thermolysis of Coal-Derived Liquids in the Absence of Hydrogen Donors

The pyrolysis of an SRC-II process recycle solvent is reviewed in Table IV (Krishnamurthy et al., 1980). This shows the partial removal of oxygen by pyrolysis, the more so at higher temperatures. Simple phenols, acetophenone/indanols, dihydrophenols, and phenylphenols are removed to various extents, while dibenzofuran and biphenols vanish completely at higher temperatures. This is really noteworthy, since removal of aromatic ethers is usually a problem in upgrading coal-derived liquids.

An extract prepared from a low-rank coal with supercritical toluene at 723 K, on the other hand, when heated up to 673 K showed little change except some conversion of phenolic to ether groups (Mortimer,

TABLE IV
 PRODUCTS OF PYROLYSIS OF SRC-II RECYCLE SOLVENT
 (Krishnamurthy et al., 1980)

| Reactor temperature (K) | | 929 | 925 | 924 | 1006 | 1001 | 1005 |
|---|------|-------|------|------|-------|------|------|
| Residence time (s) | | 0.082 | 0.11 | 0.13 | 0.084 | 0.11 | 0.12 |
| Oxygen compounds in liquid product (g h ⁻¹) | Feed | | | | | | |
| phenols, single ring | 15.3 | 11.0 | 12.5 | 12.0 | 9.1 | 8.1 | 7.2 |
| indenois | 0.35 | - | 1.1 | 1.3 | 0.87 | 1.60 | 1.2 |
| naphthols | - | - | - | - | 0.39 | 1.3 | - |
| acetophenone/indanois | 4.5 | 2.0 | 2.6 | 2.4 | 1.84 | 1.0 | 1.6 |
| dihydrophenols | 1.5 | 0.92 | 0.57 | 0.9 | 0.39 | - | 0.17 |
| phenylphenols | 2.5 | 1.6 | 1.4 | 1.6 | 1.1 | 0.74 | 0.78 |
| dibenzofuran | 4.0 | - | 2.3 | 1.6 | - | - | - |
| biphenols | 0.47 | - | - | - | - | - | - |

1980). Fourier-transformation IR studies of SRC asphaltenes before and after heat treatment at 748 K suggested that the pyrolysis caused mainly loss of alkyl and hydroxyl groups, and that the oxygen remaining was partly ketonic (Friedman, 1981).

Thus condensation of some phenolic hydroxyl groups to ether linkages is a likely mechanism for oligomerization of benzene-insoluble molecules without major structural change. Ultimately such reactions could produce char (Mortimer, 1980).

B.4. Thermal Reactions of Model Oxygen

Compounds with Hydrogen Donors

Because of interest in hydrogen-donor processes for liquefying coal, there has been much work on products of reactions of aromatic and heterocyclic compounds with tetralin and 1,2,3,4-tetrahydroquinoline. Such work is summarized in Table V, and rates of reaction are set forth in Table VI.

From the tables one can see that phenols, diaryl ethers, and heterocyclic oxygen compounds react little or not at all, while alcohols, alkyl aryl ethers, and most other functional types tested are at least partly deoxygenated.

The high reactivity of some oxygen-containing compounds, such as benzyl ethers, means that hydrogen need not always be abstracted from a good donor solvent to maintain a reaction. The hydrogen can be supplied by intramolecular rearrangement, from poor donor solvents, or from other hydrogen-containing compounds. The relative order of reactivity of oxygen compounds has been given as: benzofurans < phenols < ketones < aldehydes < aliphatic ethers (Cronauer et al., 1979).

TABLE V
REACTIONS OF OXYGEN COMPOUNDS WITH DONOR SOLVENTS

| Oxygen Compound | H donor ^a and conditions | Conversion of O-compound (%) | Main products | Reference(s) ^b |
|--|---|---------------------------------|---|---------------------------|
| Phenol | Q, 573-663 K, 3.5 h | 0 | | 6 |
| Cresols | T, 673 K, 0.08-18 h | 0 | | 3,5 |
| 2,6- and 3,5-Me ₂ - C ₆ H ₃ OH | T, 723 K | 0 | | 12 |
| o- and p-PhCH ₂ C ₆ H ₄ OH | T, 673 K, 1-2 h | | PhOH, PhMe | 2,3,20 |
| 5-Indanol | T, 673 K, 18 h | 0 | | 3 |
| 1-C ₁₀ H ₇ OH | T or 2,6-Me ₂ T or Q, 723 K | c | C ₁₀ H ₈ | 12 |
| 1-C ₁₀ H ₇ OH | T and 1-MeC ₁₀ H ₇ , 723 K, 0.5 h | ≅0 | | 16 |
| 1- and 2-C ₁₀ H ₇ OH | Q, 573 K, 4 h | 10 ^d | | 13 |
| 2-C ₁₀ H ₇ OH | T, 673-723 K, 0.08-18 h | 0 | | 3,5,16 |
| PhCH ₂ OH | T | c | PhMe | 12 |
| PhCH ₂ OH | T, 673 K, 0.08 h | 0 | | 5 |
| Ph ₂ CHOH | T and 1-MeC ₁₀ H ₇ , 723 K, 0.5 h | 79 | Ph ₂ CH ₂ | 16 |
| PhOMe and substituted anisoles | T, 618 K ^e | Various | Mainly O-demethylation, easier for o-substi- tuted ones | 4 |

TABLE V (continued)

| Oxygen Compound | H donor ^a and conditions | Conversion of O-compound (%) | Main products | Reference(s) ^b |
|--|--|---------------------------------|---|---------------------------|
| PhOEt | T, 673 K, 20 h | | PhOH, C ₆ H ₆ , PhMe, PhEt; in C ₁₀ H ₈ , some EtC ₁₀ H ₇ | 2,8, 10,11 |
| PhCH ₂ OEt | T, 573 K, 68 h | | PhMe, gases | 6 |
| Ph ₂ O | T or Q, 573-723 K, 3.5 h | 0 | | 6,7,14-16 |
| PhCH ₂ OPh | T or Q, 573-663 K ^f , 3 h | 31-100 | PhOH, PhMe, PhCH ₂ - C ₆ H ₄ OH | 6,15-17 |
| PhCH ₂ OPh | g | | PhOH, PhMe | 3 |
| PhCH ₂ OPh ^h | None, or T or Q, 648 K, 0.017 h | 42 (none), 27-30 (T or Q) | No donor: PhOH, PhMe, PhOC ₆ H ₄ Me, etc. With donor: less PhOH | 22 |
| 1-C ₁₀ H ₇ OPh | T and 1-MeC ₁₀ H ₇ , 723 K, 2 h ^f | 25 | PhOH | 16,17 |
| p-PhOC ₆ H ₄ OPh | T or Q, 658 K | 0 | | 7,14 |
| 9-phenanthryl-OPh | T and 1-C ₁₀ H ₇ Me, 723 K, 2 h ^f | 45 | PhOH, phenanthrene | 15,17 |
| m-C ₆ H ₄ (OPh) ₂ | T or Q, 658 K | 0 | | 7,14 |
| (2-C ₁₀ H ₇) ₂ O | T, 723 K, 1-2 h ⁱ | 12-23 | 2-C ₁₀ H ₇ OH | 15,16 |
| (PhCH ₂) ₂ O | T, 658-673 K, 0.5 h ^f | 65-100 | PhMe, PhCHO, C ₆ H ₆ 1-Me-indan | 7,14-17 |

TABLE V (continued)

| Oxygen Compound | H donor ^a and conditions | Conversion of O-compound (%) | Main products | Reference(s) ^b |
|---|-------------------------------------|---------------------------------|---|---------------------------|
| (PhCH ₂) ₂ O | Q, 573-663 K, 3.5 h | up to 100 | PhMe, PhEt, PhCH ₂ OH 3-Me-pyridine, polymer | 6,7,14 |
| (PhCH ₂) ₂ O | T | c | PhCHO ^j , PhMe | 12 |
| Benzyl ethers | T ⁱ , 700 K | | PhMe, etc. | 18 |
| 1-C ₁₀ H ₇ OCH ₂ Ph | T, 658 K | | PhMe, 1-C ₁₀ H ₇ OH, etc. | 7,14 |
| o-PhCH ₂ C ₆ H ₄ OMe | T, 623 K | | o-PhCH ₂ C ₆ H ₄ OH | 20 |
| p-C ₆ H ₄ (OH) ₂ | Q, 573 K, 4 h | 80 | p-Benzoquinone, quin- hydrone, PhOH, cyclo- hexanol | 13 |
| o-MeOC ₆ H ₄ OH | T, 578-618 K | up to 66 | o-C ₆ H ₄ (OH) ₂ , PhOH, o-Me- C ₆ H ₄ OH, etc. | 8 |
| p-PhOC ₆ H ₄ OH | T, 658 K | 7 | PhOH | 8 |
| | Q, 658 K | 50 | PhOH, o-MeC ₆ H ₄ NH ₂ , polymers | 7,14 |
| m-PhOC ₆ H ₄ OH | T, 658 K | 0 | - | 7,14 |
| | Q, 658 K | 24 | Polymers | 7,14 |

TABLE V (continued)

| Oxygen Compound | H donor ^a and conditions | Conversion of O-compound (%) | Main products | Reference(s) ^b |
|------------------------|--|------------------------------|---|---------------------------|
| Furan, tetrahydrofuran | T or Q, 658 K | 0 | - | 7,14 |
| Benzofuran | T or Q, 658-723 K, 0.42 h | 0-50 | o-EtC ₆ H ₄ OH, o-cresol | 7,14,19 |
| Dihydrobenzofuran | T, 698 K | | o-EtC ₆ H ₄ OH, o-cresol, benzofuran | 19 |
| Dibenzofuran | T, 723-748 K, 0.5-18 h | 0 | - | 3,12, 15,16 |
| Xanthone | T, 673 K, 0.08 h | 0 | - | 5 |
| PhCHO | T, 673 K | c | C ₆ H ₆ , PhMe | 5,12 |
| PhCOOH | T, 673 K, 0.08 h | | C ₆ H ₆ , CO ₂ | 5 |
| PhCH ₂ COOH | T, 673 K, 0.08 h | | (PhCH ₂) ₂ CO | 5 |
| PhCOMe | T, 673 K, 0.08 h | 0 | - | 5 |
| PhCOMe | T | c | PhCHMeOH as inter- mediate, PhEt | 12 |
| Ph ₂ CO | At 673 K, 17 h: 10 phenols compared as donors | | Ph ₂ CH ₂ | 21 |
| Ph ₂ CO | T and 1-MeC ₁₀ H ₇ , 723 K, 0.5 h | 29 | Ph ₂ CH ₂ | 15,16 |

TABLE V (continued)

| Oxygen Compound | H donor ^a and conditions | Conversion of O-compound (%) | Main products | Reference(s) ^b |
|--|---|---------------------------------|--|---------------------------|
| Tetralone | None T, 2,6-Me ₂ T ^c , mesitylene ^c | | C ₁₀ H ₈ , 1-C ₁₀ H ₇ OH C ₁₀ H ₈ | 12 |
| PhCH ₂ COPh | T and 1-MeC ₁₀ H ₇ , 723 K, 0.5 h | 25 | Ph ₂ CH ₂ , (PhCH ₂) ₂ | 16 |
| PhCOOMe | T, 673 K, 0.08 h | 0 | - | 5 |
| PhCOOCH ₂ Ph | T, 673 K, 0.08 h | 100 | PhMe, C ₆ H ₆ | 5 |
| 2-C ₁₀ H ₇ COOH, 1,4-Naphthoquinone | T, 673 K, 0.08 h | 100 | C ₁₀ H ₈ | 5 |
| 1-Adamantanol | T, 673 K, 0.08 h T, 698 K, 2.2 h | 0 100 | - Adamantane | 5 1 |
| 2-Adamantanone | T, 673 K, 0.08 h T, 698 K, 2,2 h | 0 0 | - - | 5 1 |
| Anthraquinone | T, 673 K, 0.08 h | | Anthracene | 5 |

^a T, tetralin, 1,2,3,4-tetrahydronaphthalene; Q, 1,2,3,4-tetrahydroquinoline.

^b 1, Aczel et al. (1979); 2, Benjamin et al. (1977); 3, Benjamin et al. (1978); 4, Bredenberg and Ceylan (1983); 5, Brower (1977); 6, Bruecker and Koelling (1965); 7, Carson and Ignasiak (1980); 8, Ceylan and Bredenberg (1982); 9, Collins et al. (1977a); 10, Collins et al. (1977b); 11, Collins et al. (1979); 12, Cronauer et al. (1979); 13, Hausigk et al. (1969); 14, Ignasiak et al. (1979); 15, Kamiya et al. (1978); 16, Kamiya et al. (1979); 17, Kamiya et al. (1983); 18, King and Stock (1982); 19, Mallinson et al. (1980); 20, McMillen et al. (1981); 21, Raaen and Roark (1978); 22, Virk (1979).

^c Dependent on temperature and time, see Table VI.

^d No reduction, but conversion to dinaphthofurans.

^e H₂ present at 6 MPa; may or may not have participated.

^f Reaction accelerated by coal ash.

^g No experiments; a pericyclic mechanism suggested.

^h Virk's mechanism not believed applicable.

ⁱ Reaction accelerated by various phenols.

TABLE VI
KINETICS OF DISAPPEARANCE OF OXYGEN COMPOUNDS HEATED WITH EXCESS TETRALIN

| Oxygen Compound | Rate constant (pseudo first order) k (s^{-1}) | | Energy of activation, E_a (kJ/mol) | Reference |
|--|---|----------------------|--|-------------------------|
| | 673 K | 723 K | | |
| 3,5- or 2,6-Me ₂ C ₆ H ₃ OH | | 5×10^{-6} | | Cronauer et al. (1979) |
| PhCH ₂ OH | 3.3×10^{-4} | 6.7×10^{-4} | 109.7 | Cronauer et al. (1979) |
| 1-C ₁₀ H ₇ OH | 6.7×10^{-6} | 3.8×10^{-5} | 142.4 | Cronauer et al. (1979) |
| o-PhCH ₂ C ₆ H ₄ OH | $5.5 \times 10^{-8^a}$ | | | McMillen et al. (1981) |
| (PhCH ₂) ₂ O | 8.0×10^{-4} | 4.2×10^{-3} | 150.7 | Cronauer et al. (1979) |
| (PhCH ₂) ₂ O hydroquinoline) | (In either tetralin or tetra- | | 160.8 | Panvelker et al. (1982) |
| PhCH ₂ CH ₂ OPh at 573-773 K) | (Either neat or in tetralin | | 188.4 ± 11.3 | Klein and Virk (1983) |
| o-MeOC ₆ H ₄ OH | 1.1×10^{-5} | 4.5×10^{-5} | 213.5 (1982) | Ceylan and Bredenberg |
| PhCHO | 4.2×10^{-4} | 2.0×10^{-3} | 134.0 | Cronauer et al. (1979) |
| PhCHO hydroquinoline) | (In either tetralin or tetra- | | 134-138 | Panvelker et al. (1982) |
| PhCOMe | 1.3×10^{-5} | 7.2×10^{-5} | 140.3 | Cronauer et al. (1979) |

TABLE VI (continued)

| Oxygen Compound | Rate constant (pseudo first order) k (s ⁻¹) | | Energy of activation, E _a (kJ/mol) | Reference |
|---------------------------|---|--------------------------------|---|-------------------------|
| | 673 K | 723 K | | |
| PhCOMe hydroquinoline) | (In either tetralin or tetra- | | 134-138 | Panvelker et al. (1982) |
| Tetralone | 3.2 x 10 ⁻⁵ | 1.1 x 10 ⁻⁴ | 103.6 | Cronauer et al. (1979) |
| Benzofuran | 9.8 x 10 ⁻⁵ | 4.7 x 10 ⁻⁴ (773 K) | 125.6 | Mallinson et al. (1980) |
| Dihydrobenzofuran | 3.3 x 10 ⁻⁶ | 4.7 x 10 ⁻⁵ (773 K) | 214.4 | Mallinson et al. (1980) |

^a Half-lives observed and those calculated from bond strengths did not agree well.

B.5. Thermal Reactions of Oxygen Compounds with Molecular Hydrogen

Phenol at 763 K under 10-30 MPa H_2 for 3 h gave C_6H_6 , Ph_2 , p-cresol, dibenzofuran, and its tetrahydro derivative, besides of course gases (Gonikberg and Li, 1958). Similar work with o-cresol gave $PhOH$, $PhMe$, and C_6H_6 (Gonikberg and Li, 1960a), and the order of ease of dehydroxylation was found to be $o > p > m$ (Gonikberg and Li, 1960b). Cresols at 973-1008 K, 5.2-5.4 MPa, and liquid hourly space velocity (LHSV) 0.8-2.6 h, with H_2 /cresol mole ratio 3.2-4.8, underwent conversion of 88-92% yielding phenol 52% (Dedinas et al., 1968). Hydrolysis of xylenols yields less phenol since cresols are formed as intermediates. This reaction can be utilized to produce phenol and benzene from mixed, raw cresylic acids (Huibers and Gendler, 1981). Hydrogenolysis of propylphenols was also investigated, with similar results (Gonikberg and Li, 1961). The work of Cypres and Bettens (1974) on pyrolyzing phenol and cresols was conducted in hydrogen at high temperature, and that of Ceylan and Bredenberg (1982) on guaicol (see Table V) used a hydrogen atmosphere that did not participate in the reaction. Krishnamurthy and others (1981), using H_2 at 10.6 MPa and 623 K, found o- PhC_6H_4OH not to react but o- $C_6H_{11}C_6H_4OH$ to be 60% converted in 2 h to $PhOH$ and C_6H_{12} ; reaction of hydrogen is not clear.

Shabtai et al. (1983) reported that at 673 to 823 K, diaryl ethers have a much higher resistance to cleavage (thermal hydrocracking) than diaralkyl ethers, with aryl alkyl ethers being in between, showing the same pattern of pyrolysis without H-donors or molecular hydrogen.

C. Catalytic Hydrogenolysis of Oxygen Compounds in Coal Liquids

A large number of papers dealing with catalytic treatment of coal liquids have been summarized by Crynes (1981a,b), and Seapan and Crynes (1981) and Zhou et al. (in press). More information about reactivities, reaction mechanisms, and kinetics in hydrodeoxygenation has now become available.

C.1. Catalytic Hydrodeoxygenation of Oxygen-Containing Model Compounds

The hydroxyl group of a phenol can be removed by either direct dehydroxylation to a benzene, which may or may not be further reduced to a cyclohexane, or indirect dehydroxylation. The latter goes by conversion to a cyclohexanol and a cyclohexene, without possibility of isolation of the intermediates under severe conditions.

For phenol itself, both mechanisms usually operate, but Co-Mo-alumina catalysts favor the direct route (Moldavskii and Livshits, 1933; Haider et al., 1981b; Weigold, 1982) except at hydrogen pressures <10 MPa (Roberti, 1931, 1932; Polozov, 1935). Ni-Mo-alumina catalysts promote the indirect route (Haider et al., 1981b) but only slight conversions were attained with this catalyst at 523 K and 5 MPa H_2 (Bredenberg et al., 1982).

The same difference is observed for p-cresol, the cobalt-based catalyst giving toluene and the nickel-based methylcyclohexane (Alekseeva and Moldavskii, 1959; Wailes, 1982). The HDO of cresols was investigated as a source of toluene, with yields up to 87% (Cawley et al., 1946), and the thermal or catalytic dealkylation of mixed alkyl-

phenols in hydrogen at 7.2 MPa and 873 K gave 20-25% yields of PhOH and 25-35% of hydrocarbons (Jelinek, 1963). Yields of hydrocarbons in HDO of phenols vary considerably over Co-Mo catalyst at 573 K ranging from <1% for *o*-EtC₆H₄OH to 48% for *m*-MeC₆H₄OH (Weigold, 1982). Rates also vary, the cresols reacting in the order *m* > *p* > *o* (Odebumni and Ollis, 1983a). In a series of experiments, relative to PhOH taken as 100, carvacrol (2-Me-5-isoPrC₆H₃OH) reaction rate was lowest at 44.9 and C₁₀H₇OH highest at 208 (but PhSH rate was 2845!) (Bobyshev et al., 1940). Another set of runs over Co-Mo-alumina at 617 K and 4.9 MPa H₂, using C₁₀H₈ = 100, showed dibenzofuran slowest at 30-40 and *p*-MeCH₂CH₂C₆H₄OH fastest at 760 (but an alcohol, *cis*-2-PhC₆H₁₀OH, had a value of 1000) (Rollman, 1977).

The ready catalytic HDO of naphthols, *p*-cresol, and benzenediols has been confirmed (Whitehurst et al., 1979; Mitchell, 1979), and the steric hindrance to HDO in ortho-substituted phenols is evident (Weisser and Landa, 1973; Rollman, 1977; Weigold, 1982; Odebumni and Ollis, 1983c). Simple phenolic ethers react readily by initial dealkylation and then like the parent phenol, except that ring alkylation of the phenol may be observed (Rieche et al., 1966). Dibenzyl ether, as might be expected, is very readily degraded (Kawa and Hiteshue, 1963; Cronauer et al., 1979), while diphenyl ether requires much more drastic treatment (Kawa and Hiteshue, 1963; Medepalli and Kao, 1981).

As to heterocyclic ethers, tetrahydrofuran gave gases but no furan (Furimsky, 1983a), benzofuran reacted just like *o*-EtC₆H₄OH (Landa et al., 1969; Rollman, 1979), and dibenzofuran gave the tetrahydro-derivative plus *o*-PhC₆H₄OH (Hall and Cawley, 1939; Landa et al., 1969; Krishnamurthy et al., 1981), then degradation products of the phenol:

2-substituted hydrogenated phenols, phenol itself, and hydrocarbons. 2,2'-Biphenol yielded dibenzofuran and then products of its hydrogenolysis (Hall and Cawley, 1939), and xanthene produced phenols (Landa et al., 1969). However, even with the most active catalysts investigated by Shabtai and Shukla (1983), oxygen removal is difficult for benzofuran and dibenzofuran.

1- and 2-tetralone at about 373 K with either Ni-Mo or Co-Mo catalysts are reduced only to the alcohols, but these at 473-573 K give tetralin, $C_{10}H_8$, and hydrogenated dimers (Haider et al., 1981a).

C.2. Hydrodeoxygenation of Coal-Derived Liquids

In hydrotreating coal-derived liquids, the principal catalytic reactions are HDO, HDN, HDS, some hydrogenation of aromatics, and slight hydrocracking; the most important of these is heteroatom removal, and in the present context, removal of oxygen.

A single-stage hydrotreatment of light fractions of coal hydrogenation liquids removed most heteroatoms, but little of dibenzofuran (Armstrong, 1982). Preasphaltenes of the liquids made by hydrogenation of Akabira coal were themselves hydrogenated at 658 K with red mud/sulfur catalyst at 10 MPa; their conversion to asphaltenes and oil was considered to involve breaking of ether linkages to give phenols, plus saturation of some aromatic rings (Ouchi et al., 1981). In heavy coal-derived liquids that had been hydro-upgraded, the total heteroatom content of asphaltene fractions decreased as their molecular weight increased. This suggests that smaller molecules with relatively large heteroatom contents are preferentially converted to oil; whereas,

large molecules having low amounts of heteroatoms are concentrated in the remaining asphaltenes (Tewari et al., 1981).

Contrary to some opinion, oxygen is not more easily removed than nitrogen. Hydroprocessed coal-liquid fractions usually retain 0.1-2 wt.% oxygen while nitrogen and sulfur levels are much lower (Satterfield et al., 1980). The severity of treatment required to remove oxygen from COED process liquids derived from various coals was in the order of: Pittsburgh coal 2.5, Illinois coal 1.0, and Utah coal 0.8 (Jacobs et al., 1970). Oxygen levels were reduced from 6.6-9.1 wt.% to 0.0-0.7 wt.%.

Similarly, improvement in SRC, Synthoil, and H-Coal liquids by hydrotreating reduced oxygen contents from 2.27-4.39 wt.% to 0.20-0.39 wt.% (deRosset et al., 1977). Catalysts compared for upgrading SRC liquids affected 30% to 80% removal of oxygen, with about the same activities for sulfur removal (Shih et al., 1980). A Ni-Mo catalyst used at 10MPa and 648 K did not cause HDO until titanocene dichloride was added as promoter, and even then oxygen content was lowered only from 9.6 to 7 wt.% (Chan et al., 1982). Hydro-upgrading destroyed dihydric phenols and naphthols, but did not change levels of alkylphenols, and actually increased alkylindanols (Hill et al., 1981).

In summary, two main reaction paths are involved; these depend on catalyst, temperature, and steric hindrance by ortho substituents. Two paths are also common for oxygen heterocycles, but saturation of the heterocyclic ring is generally equilibrium-controlled and might possibly limit conversion. Five-membered rings are easier to hydrodeoxygenate than six-membered rings, and species with fewer condensed benzene rings react more easily than those containing more (Krishnamurthy, 1980).

Various catalysts behave differently as regards HDO of coal liquids. A Co-Mo catalyst was found more active for oxygen and sulfur removal than was Ni-Mo catalyst (Asim et al., 1983). Yoshida and his group (1983) proved that zeolite catalysts could remove oxygen as Co and/or CO₂, and commercial HDS catalysts had a high activity for HDO also.

The effects of heterocyclic compounds on catalyst activity must also be considered. For example, in simultaneous catalytic HDO-HDN of model compounds, the HDO of an ethylphenol was retarded by quinoline or *o*-EtC₆H₄OH (Satterfield and Yang, 1983). In somewhat similar experiments, nitrogen and sulfur compounds suppressed direct HDO, presumably by blocking the catalytic sites needed for hydroxy group transfer (Weigold, 1982). Hydrogen sulfide inhibits oxygen elimination as well as the extent of conversion for phenols and ethers (Shabtai and Shukla, 1983).

Mutual inhibition of HDO and HDS was observed for mixtures of benzothiophene and *m*-cresol (Odebumni and Ollis, 1983a), and of HDO/HDN in mixtures of indole with *m*-cresol, all over a Co-Mo catalyst (Odebumni and Ollis, 1983b).

C.3. Kinetics of Hydrodeoxygenation of Coal Liquids

The rate of hydrogenolysis of cresols, as model compounds, was studied with a Ni-W catalyst (Guenther, 1953). The reaction was first order in cresols, with an activation energy of 235.3 kJ/mol for the undiluted phenols and 81.2 kJ/mol for a 3% solution in a hydrogenated

oil, suggesting the operation of diffusional or other mass transfer effects.

Oils produced by the COED process from Pittsburgh seam coal and Illinois No. 6 coal were hydrogenated by Jacobs et al. (1971). Again, data were correlated by a pseudo-first-order rate law, with activation energy of 34.8 kJ/mol for removal of oxygen. For a blend of SRC-I and SRC-II hydroprocessed catalytically, Tewari and co-workers (1981) found a pseudo-first-order expression to fit the relation between contact time and removal of phenolic OH as well as total nitrogen. Rollman (1977) also derived a first-order rate expression for heteroatom elimination.

For hydrotreating of an SRC-I naphtha, first-order kinetics applied quite well for HDO and HDN reactions, with activation energy of 105-126 kJ/mol. The reaction was not mass-transfer or pore-diffusion limited (Asim et al., 1983). Gates and Petrakis (1983) derived pseudo-first-order constants for the disappearance of thiophenes and furans in the neutral oils from SRC-II heavy distillate, the rate constant for HDO being one order of magnitude smaller than that for HDS.

However, several authors have found the kinetics more complex. For both a Utah COED coal liquid (White et al., 1968) and low-temperature tar from a Utah coal (Qader et al., 1968), Arrhenius plots of first-order rate constants for removal of oxygen showed two nearly linear sections, with change of slope at 653-673 K. The energies of activation for the Utah coal liquids were found to be 160.4 kJ/mol (exceptionally high) at about 653 K and 19.7 kJ/mol (likely representing merely diffusion control) above 653 K. For the low-temperature tar, activation energies were 50 kJ/mol (573-673 K) or 33.5 kJ/mol (673-773 K); these were considered to indicate that both processes were chemical in nature.

On the other hand, a second-order rate equation with a first-order pressure dependence and an Arrhenius temperature dependence was found to fit the data for oxygen (and also for nitrogen and sulfur) removal from an SRC recycle solvent and an H-Coal distillate (Heck and Stein, 1977). The reaction rate for oxygen was 0.7-1.4 order in reaction pressure, with an activation energy of 132.7-153.7 kJ/mol. Stein and coworkers (1978) fitted a second-order rate law to similar data but obtained somewhat lower values of Arrhenius constants. A similar value for activation energy for HDO, 134.2 kJ/mol, has been used for SRC liquid hydroprocessing (Shih et al., 1980).

In summary, the kinetics of catalytic HDO of coal-derived liquids can be represented by either pseudo-first-order or second-order rate equations. This is not surprising, for in many of these complex heterogeneous catalytic systems, a variety of factors, physical and chemical, influence the reaction and their effects can usually be lumped together into the constants no matter which rate expression is used. We must recognize that such expressions are only models, not mechanisms, but these are still useful to process experimental data and for design purposes. Indeed, with these extremely complex feedstocks, more sophisticated, rigorous models might be difficult to construct or justify.

D. Hydrogen Consumption and Coke Formation in Coal Liquid Upgrading

Efficient utilization of hydrogen, and maintenance of catalyst performance, are important factors in coal-liquid upgrading for economic reasons.

D.1. Hydrogen Consumption During Hydro-Upgrading

Conventional hydrotreating of coal-derived liquids causes essentially no hydrogenation of aromatic hydrocarbons; nearly all the hydrogen consumed is used for the removal of heteroatoms. Such hydrogen can be divided into two parts: first, hydrogen consumed in heterocyclic ring saturation, and second, hydrogen spent on C-X (X = O, N, and S) bond breaking producing H₂O, NH₃ and H₂S.

In general, nitrogen compounds require prior ring saturation before removal of the nitrogen, whereas sulfur compounds may or may not. For oxygen compounds that require such ring saturation, removal of oxygen from a phenol or a benzofuran must involve 4-6 moles of H₂ per mole of H₂O produced (Rollman, 1977). A linear relation was observed between oxygen removal and hydrogen consumption of a Tacoma filtrate (Givens et al., 1979), although an older report found no such simple relationship for coal treatment (Storch et al., 1943). The recent work showed that 9 hydrogen atoms were required to remove one oxygen atom, close to the stoichiometric value for ring saturation.

Of the 70-80% of the hydrogen consumed in heteroatom removal, considerably more goes to remove oxygen than nitrogen and sulfur together (Heck and Stein, 1977). On a relative gram-atom basis the number of oxygen atoms removed at higher temperatures is much larger than for nitrogen, which in turn is larger for sulfur (Givens et al., 1979). The dependence of this difference on temperature makes the hydrogen consumption for the total feed quite uncertain. Differences in catalysts used cause further complication, as observed by Givens and others (1979), because the reaction pathways of phenols depend strongly

on catalyst characteristics, as already noted. This probably accounts for the scatter of data reported by various authors.

The observed difference between Co-Mo and Ni-W catalysts (Haider et al., 1981b) with respect to hydrogen consumption for phenol deoxygenation means that such HDO in coal liquids with a sulfided Ni-W catalyst would probably require much the higher hydrogen consumption.

Thus more work on hydrogen consumption in deoxygenation of coal liquids is necessary. If optimum operating conditions (temperature, pressure, space velocity) could be obtained for different types of feedstocks and catalysts, hydrogen requirements and, thus, operational costs would be reduced. A thorough mechanistic study of reactions of representative oxygen compounds, thermally and catalytically, under various conditions, is needed. This would provide more information on catalyst selection and development, optimum combination of thermal and catalytic treatment, and choice of suitable reaction routes (direct extrusion of oxygen from heterocyclics, elimination of oxygen in the form of carbon oxides), so that hydrogen consumption could be minimized.

D.2. Role of Oxygen Compounds in Coke Formation

A major problem in the catalytic upgrading of coal-derived liquids is rapid catalyst deterioration. This is believed due to 1) permanent poisoning by trace metal deposition, 2) temporary deactivation of acidic active sites by basic components of coal liquids, and 3) physical coverage of active surface and blocking of catalyst micropores by carbonaceous deposits -- coke. Our concern here is only with the role that oxygen compounds may play in coke deposition. This has been mentioned in a review by Whitehurst and others (1980).

As pointed out by Shabtai and Shukla (1983), during oxygen removal coke precursors are readily formed. Mortimer (1980) examined the thermal behavior at 423 and 573 K of a liquid obtained by supercritical-toluene extraction of a low-rank coal. He concluded that condensation of some phenolic hydroxyl groups to ether linkages is a likely mechanism for oligomerization of benzene-insoluble molecules, ultimately into insoluble char. Experimental results of Whitehurst and coworkers (1979) agree that phenols are the main species thus involved. The tendency toward char formation of SRC components seems to be closely related to high chemical functionality.

Ethers, especially benzyl ethers, upon pyrolysis also give high-molecular-weight species, which become heavier as the available hydrogen or hydrogen donor is decreased. In the absence of such added hydrogen, increasing reaction severity leads to polymerization and ultimately to coke (Schlosberg et al., 1981a,b).

The oxygen compounds in coal-derived oils not only induce formation of coke but also affect its structure (Marsh et al., 1973; Korai et al., 1981).

Extracts were obtained from catalyst pellets used in hydro-upgrading a feedstock free of metals and asphaltenes (Furimsky, 1982). Analysis of these extracts indicated that aromatic compounds, especially phenols and nitrogen-containing species, are the main precursors of deposits. After a study of HDO of tetrahydrofuran, Furimsky (1983b) suggested a mechanism for deposit formation. This includes combination of two radicals generated by C-C bond rupture in a transient state, followed by intramolecular rearrangement giving an aromatic structure. The oxygen atom is supposed to be eliminated as water or else remains

attached to the catalyst surface but does not participate in coke formation.

E. Concluding Remarks

The foregoing literature review serves to state the present status of progress in this field. Although the abundance of oxygen compounds, especially phenols, in coal-derived liquids and their influence on upgrading technology and economics is recognized, their chemical behavior, particularly their thermal reactivities and reaction mechanisms under various conditions, have not been thoroughly investigated so far and remain to be a terra incognita. Any effort to search in this area would contribute to the knowledge of coal-oil technology.

CHAPTER III

EXPERIMENTAL APPARATUS

For this study, a batch autoclave reactor system was designed, constructed, tested and made operable. Thermal reactivities of selected model, organic, oxygen-containing compounds, isomeric ethylphenols, in a carrier solvent dodecane, and also pure *o*-ethylphenol and pure solvent, were investigated through twenty experimental runs in this system, under various temperatures, pressures and different environments. Ten to twenty gas and liquid samples were collected for each run from the reactor and analyzed by means of gas chromatography to obtain conversion and yield data. A GC/MS technique was employed to analyze a number of representative samples to identify some unknowns and check with the routine chromatographic analytical results.

An autoclave batch reactor system was chosen because:

1. The reaction time can be conveniently defined and chemical changes with respect to time monitored.
2. There are classic methods to handle the reaction kinetics of batch reactions.
3. The use of an autoclave of reasonable size (one liter) does not consume too much reagent grade chemicals.

The literature survey in the previous chapter has dictated the importance of phenols in coal-derived liquids and their hydro-processing. Ethylphenols are representative of single-ring phenols

in coal liquids in that they have an alkyl side chain of approximately the average length. In view of the adverse effect of steric hindrance and hence the difficulty of elimination of ortho-substituted phenols during catalytic hydrotreatment, particular attention was paid to o-ethyl-phenol.

A. The Reactor System

A.1. The Flow Scheme

The flow scheme of the batch autoclave system is shown in Figure 4 and the reactor shown in Figure 5. The major part of the solvent was loaded in the reactor and the rest was mixed with a certain amount of ethylphenol and loaded in the feed storage tank at ambient temperature and pressure. After the whole system had been thoroughly purged with N_2 or H_2 , the feed in the storage tank was allowed to flow into the feed tank and preheated to 573 K. When the reactor temperature reached the desired value, the liquid in the feed tank was instantly injected into the reactor by means of a positive pressure difference between the feed tank and reactor. The reactor section of the system was maintained under constant temperature and pressure and samples were collected. The gas sampling line passed through a trap of a volume of $5 \times 10^{-4} \text{ m}^3$, the condensate was released and collected. In the meantime, a gas sample was taken into a sampling bag after metering. Just prior to liquid sampling, the residual liquid in the sampling line was forced back to the reactor by means of a pressure difference of 0.34 MPa between the sample tank and the reactor. The pressure in the sample tank was reduced first to 3.5 MPa, held for 120 s, and then 0.8 MPa and kept there for 180–300 s. The flash gas produced in the sample tank flowed

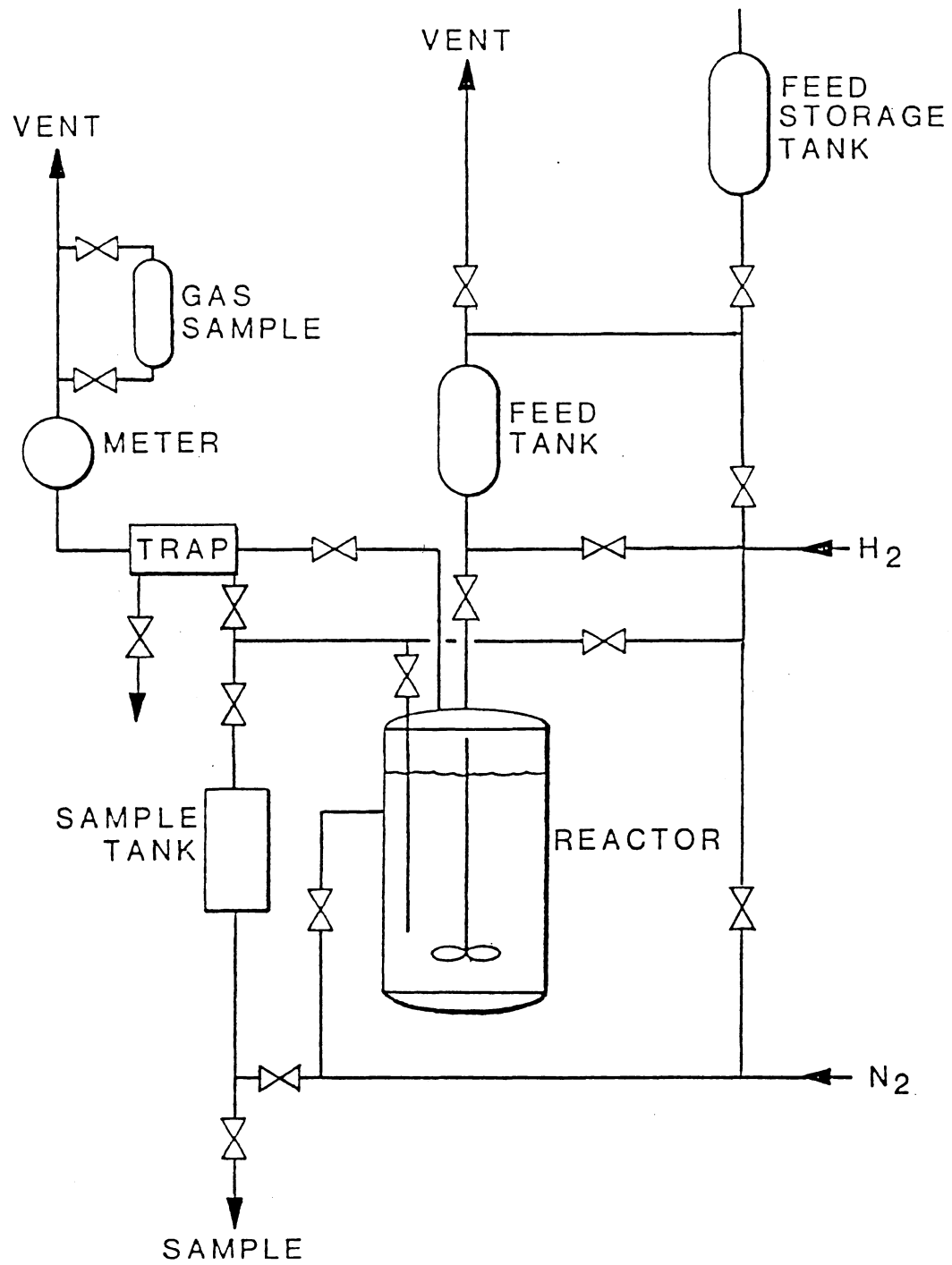

Figure 4. Batch Autoclave System

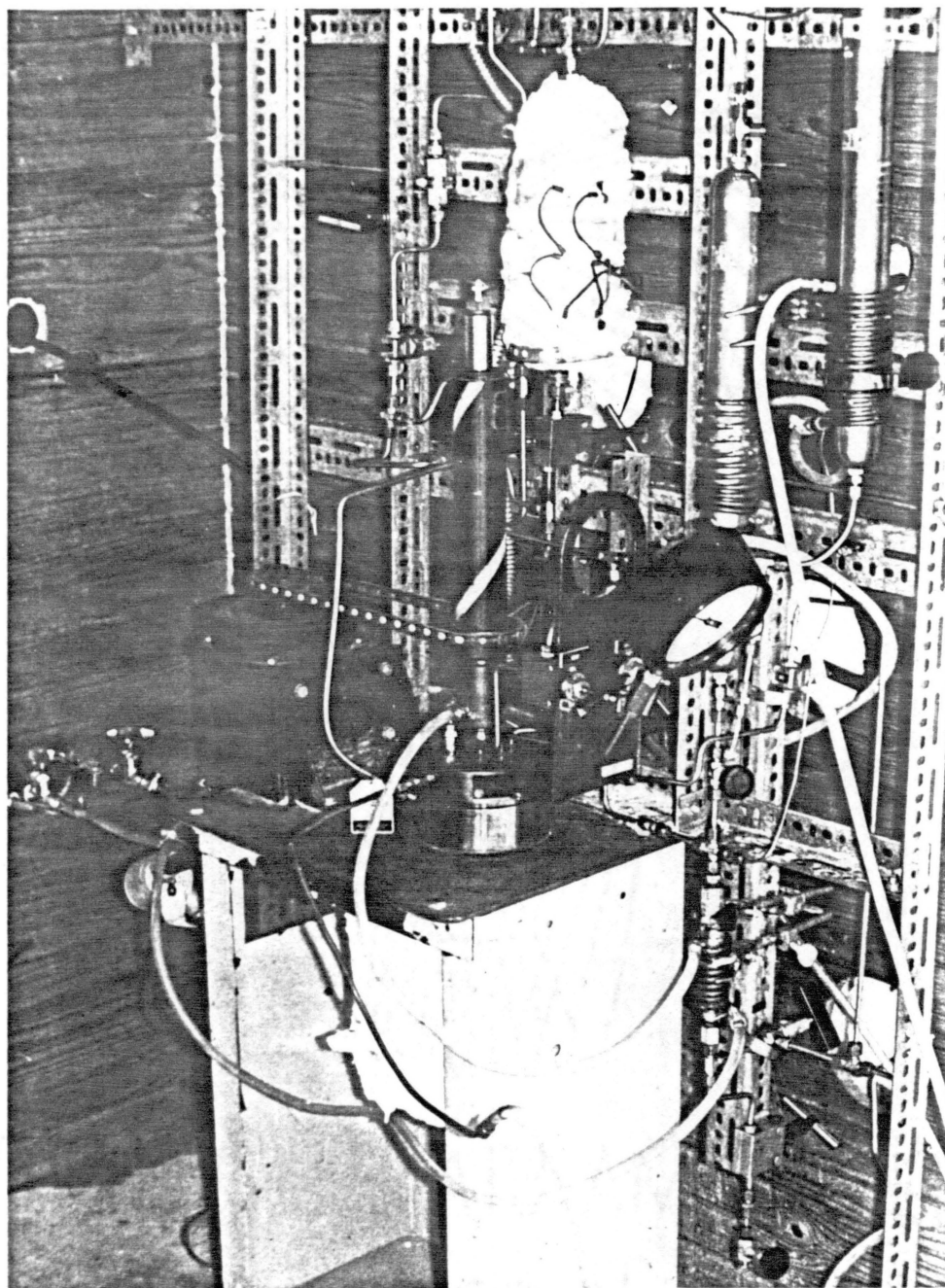

Figure 5. Batch Reactor System

through a separate trap (shown in Figure 5); liquid carryover and condensate flowed back to the sample tank during the 300-s period and then a liquid sample was released, collected and kept in a freezer, for analysis.

The reactor system was equipped with two chromel-constantan thermocouples, one situated in the feed tank and temperature displayed on an Omega Multipoint Display Trendicator. Another measured the reactor temperature, which was controlled by a Honeywell R7355 Dialatrol Proportioning Temperature Controller, actuating the reactor heater with a capacity of 6120 Kj/h. The reactor temperature was controlled to within ± 1 K in most of the run time.

The feed tank, reactor, and sample tank were equipped with pressure gauges and the reactor pressure was controlled by a Grove Mity-Mite Model 94 downstream pressure reducing valve to within 0.07 MPa.

A.2. The Reactor

All reactions were carried out in an 0.001-m^3 autoclave (Autoclave Engineers, 316 ss) with internal diameter of 0.076 m and height of 0.229 m. A glass liner of diameter 0.0747 m and length 0.191 m was employed to minimize the metal wall effect.

For pure o-ethylphenol (OEP) runs $2.0\text{-}2.5 \times 10^{-4} \text{ m}^3$ of feed was used, and for other runs $4.0\text{-}5.0 \times 10^{-4} \text{ m}^3$. Hence, a part of the reactor contents was always gas phase.

A stirrer was vertically situated in the center of the reactor, which operated at 3.0×10^4 rph during reaction. Mixing experiments showed that within 60 s a uniform liquid mixture was formed from a layer

of $4.0 \times 10^{-4} \text{ m}^3$ dodecane originally loaded in the reactor and $1.0 \times 10^{-4} \text{ m}^3$ of OEP in dodecane solution injected into the reactor. This ensured that homogeneity was achieved in the liquid phase inside the reactor.

Two rupture discs with bursting pressures of 20 and 27.6 MPa were attached to the reactor.

The reactor was also equipped with a cooling coil so that water could be introduced at the time quenching was required.

Appropriate operational procedure, including system purging and cleaning, feed injection, product sampling, and reaction quenching as well as product analysis were designed and conducted throughout this research (refer to Appendix A for a full description and file of data).

B. Materials

The chemicals used in this investigation were from the following sources, listed with the manufacturer's specifications:

| | | |
|---------------|--|---|
| Dodecane | Fisher Scientific Co. | Purified grade |
| o-Ethylphenol | Eastman Kodak Co. | Reagent grade |
| p-Ethylphenol | Eastman Kodak Co. | Reagent grade, 99% min by GLC |
| m-Ethylphenol | Aldrich Chemical Co. | 99%+ purity |
| Hydrogen | Union Carbide Corp., Linde Division | Prepurified specialty gas grade, 99.99% purity claimed |
| Nitrogen | Union Carbide Corp, Linde Div. | Ultra high purity grade, 99.99% purity claimed |

The organic chemicals were analyzed by GC and o-ethylphenol by GC/MS also. The results are given below:

| | |
|---------------|-------------------|
| Dodecane | 99.9+ wt.% purity |
| o-Ethylphenol | 99.5+ wt.% purity |
| p-Ethylphenol | 99.5 wt.% purity |
| m-Ethylphenol | 99.5 wt.% purity |

Since in all cases the purity of the chemicals was in excess of 99.5 wt.%, they were used as received. No purification was attempted on the gases.

The impurity found in dodecane used in this work is mainly undecane. The OEP employed for experiment has the following impurities identified by GC analysis: phenol 0.042%, o-cresol 0.268%, PEP 0.066%, MEP 0.024%, xylenols 0.022%, and heavy compounds 0.025%, all on a molar basis. The heavy compounds, as detected by GC/MC, are: o- and p-propylphenol, p- and m-isopropylphenol, 4-t-butylphenol, and possibly very small amounts of octylphenol and isomeric nonylphenols.

CHAPTER IV

EXPERIMENTAL RESULTS

In all, 20 reaction runs were conducted in this study. The list follows:

TABLE VII
REACTION RUN LIST

| Run No.* | Reactant | Environment | Temperature (K) | Pressure (MPa) | Run length (h) |
|----------|-----------------|----------------|-----------------|----------------|----------------|
| 1 | Dodecane | N ₂ | 673-713 | 10.3 | 3.33 |
| 2 | Dodecane | N ₂ | 523-673 | 10.3 | 3.67 |
| 13 | Dodecane | N ₂ | 673 | 9.2 | 5.00 |
| 7 | Dodecane | N ₂ | 623 | 9.2 | 8.50 |
| 12 | Dodecane | N ₂ | 623 | 9.2 | 6.67 |
| 14 | Dodecane | H ₂ | 623 | 9.2 | 6.67 |
| 3 | OEP in dodecane | N ₂ | 623 | 9.2 | 9.25 |
| 6 | OEP in dodecane | N ₂ | 623 | 9.2 | 9.25 |
| 8 | OEP in dodecane | N ₂ | 648 | 9.2 | 6.17 |
| 4 | OEP in dodecane | N ₂ | 673 | 9.2 | 2.33 |
| 5 | OEP in dodecane | N ₂ | 673 | 7.0 | 3.50 |
| 9 | OEP in dodecane | N ₂ | 623 | 4.7 | 8.00 |

TABLE VII (continued)

| Run No.* | Reactant | Environment | Temperature (K) | Pressure (MPa) | Run length (h) |
|----------|-----------------|----------------|-----------------|----------------|----------------|
| 10 | OEP in dodecane | H ₂ | 623 | 9.2 | 8.00 |
| 21 | OEP in dodecane | H ₂ | 623 | 9.2 | 6.67 |
| 20 | OEP in dodecane | H ₂ | 623 | 15.6 | 6.67 |
| 15 | o-Ethylphenol | N ₂ | 623 | 9.2 | 6.67 |
| 16 | o-Ethylphenol | H ₂ | 623 | 9.2 | 6.67 |
| 17 | PEP in dodecane | N ₂ | 623 | 9.2 | 6.67 |
| 18 | MEP in dodecane | N ₂ | 623 | 9.2 | 6.67 |
| 19 | MEP in dodecane | H ₂ | 623 | 9.2 | 6.67 |

* Run No. 11, an attempt to use naphthalene as carrier solvent, failed because of system plugging due to high freezing point of said compound.

Detailed material balances were made for ten experimental runs (Table XVIII, Appendix B). Feed charged was the input. Liquid samples, gas condensates and the residual liquid were the liquid recovered. The remainder was the sum of gas samples, residual gas in the reactor, and loss (Figure 6).

The average gas plus loss was 3.56 wt%. The loss was composed of three parts: the liquid splashed while purging the sampling system before sample collection, the liquid attached to surfaces inside the system and the gas leaked. This loss would have no significant

influence on either gas or liquid compositions, and hence none on conversion and yield data.

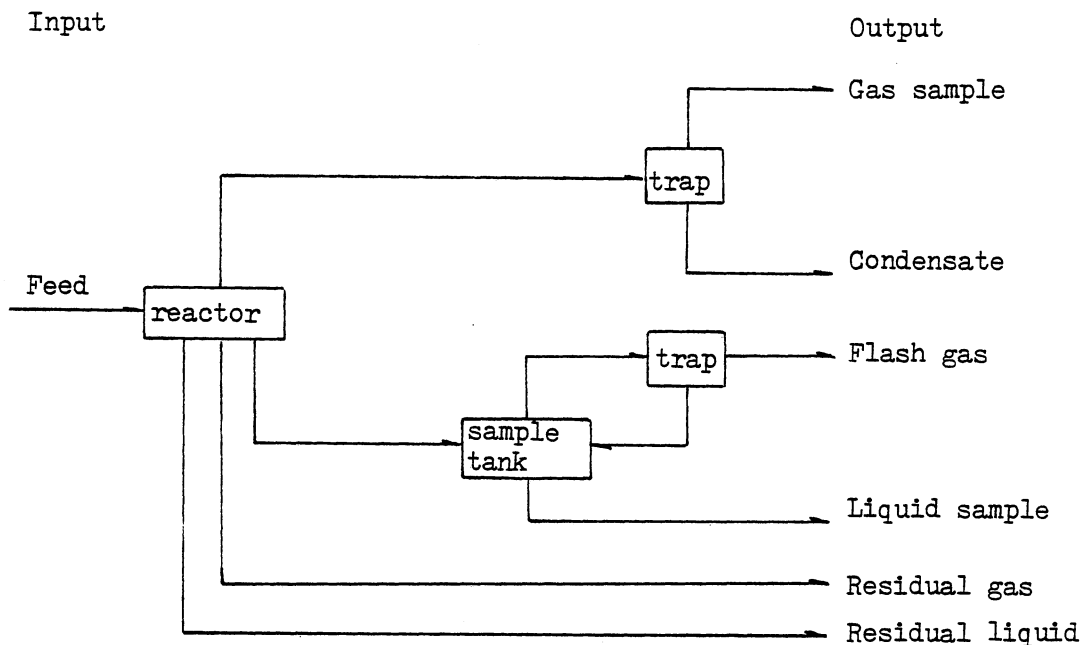

Figure 6. Material Balance of Experimental Runs

A. Thermal Reactions of Dodecane

By design, a carrier solvent without hydrogen-donor ability was required in this study. It had to be a hydrocarbon to simulate the environment to which the oxygen compounds are exposed when coal-derived liquids are processed. It should have a reasonably high boiling point and critical temperature and be thermally stable to avoid complications of product analysis. Dodecane was chosen on the basis of these considerations.

Dodecane has been employed as carrier solvent in hydrotreatment studies (e.g. Krishnamurthy et al., 1981), but its thermal stability was

not mentioned and its cracking behavior not taken into account. Our preliminary experiments showed that under temperatures not extremely high, say 660 K, dodecane did undergo a certain degree of conversion, thus creating a necessity to investigate its thermal reactivity under conditions used in the present work.

Table XIX (Appendix B) shows data obtained from Run 2, under 10.3 MPa nitrogen pressure and varying temperature. Under temperatures lower than 635 K, for a period of 1.67 h, the dodecane conversion was about 0.3 wt.% so that it can be considered relatively stable under mild conditions. Nevertheless, under severe conditions the thermal reactivity of dodecane could by no means be neglected and needed to be examined further.

A.1. Thermolytic Conversion of Dodecane

Figure 7 shows the conversion of dodecane by thermolysis under various conditions. Relevant data are presented in Tables XX to XXIV (Appendix B).

Run 7 and Run 12 are duplicates and are consistent with each other. The conditions for these two runs are the main conditions used in ethylphenol thermolysis runs. Calculated from molar percentage data, the conversion for dodecane thermolysis, at a reaction period of 6.67 h, was 1.3%. However, at 673 K, under similar system pressure, for a reaction time of 5.0 h, the conversion of dodecane was much higher (about 35%).

A.2. Product Distribution of Dodecane

Thermolysis

From Tables XXII to XXIV, product distributions of representative dodecane runs, No. 12 (623 K, 9.2 MPa N₂), No. 13 (673 K, 9.2 MPa N₂), and No. 14 (623 K, 9.2 MPa H₂), are plotted in Figures 8 to 10. Details for the formation of individual paraffins and olefins are plotted in Figures 11 to 14. Owing to the impurities (mostly C₁₁) in dodecane and minute conversion during the heat-up period, there were very small amount (~ 0.1 mol %) of lighter hydrocarbons present in the zero-reaction-time samples. For the sake of clarity in comparison, Figures 8 to 11 were constructed so that all curves pass through the origin.

Reaction products of dodecane thermolysis can be divided into two groups: those with molecular weights lower than the reactant, the decomposition products, and those with molecular weights higher than dodecane, the condensation products. In the gas chromatograms of liquid samples taken from dodecane thermolysis, the division of these two groups of products is clear at a glance. The first peak corresponds to a mixture of light hydrocarbons: butane, butene(s), pentane, pentene(s) and less probably propane and propylene. Their retention times are short and coincide in this case, hence they merge. Hexane and higher hydrocarbons were well resolved.

Owing to vaporization loss of light components, mostly pentane and lighter, during the analysis of liquid samples, the data for pentane and lighter are less reliable than other data. However, there is clearly a decreasing order in the product yields with increasing molecular weights: $C_6+C_6^= > C_7+C_7^= > C_8+C_8^= > C_9+C_9^= > C_{10}+C_{10}^= > C_{11}+C_{11}^=$. In runs 12

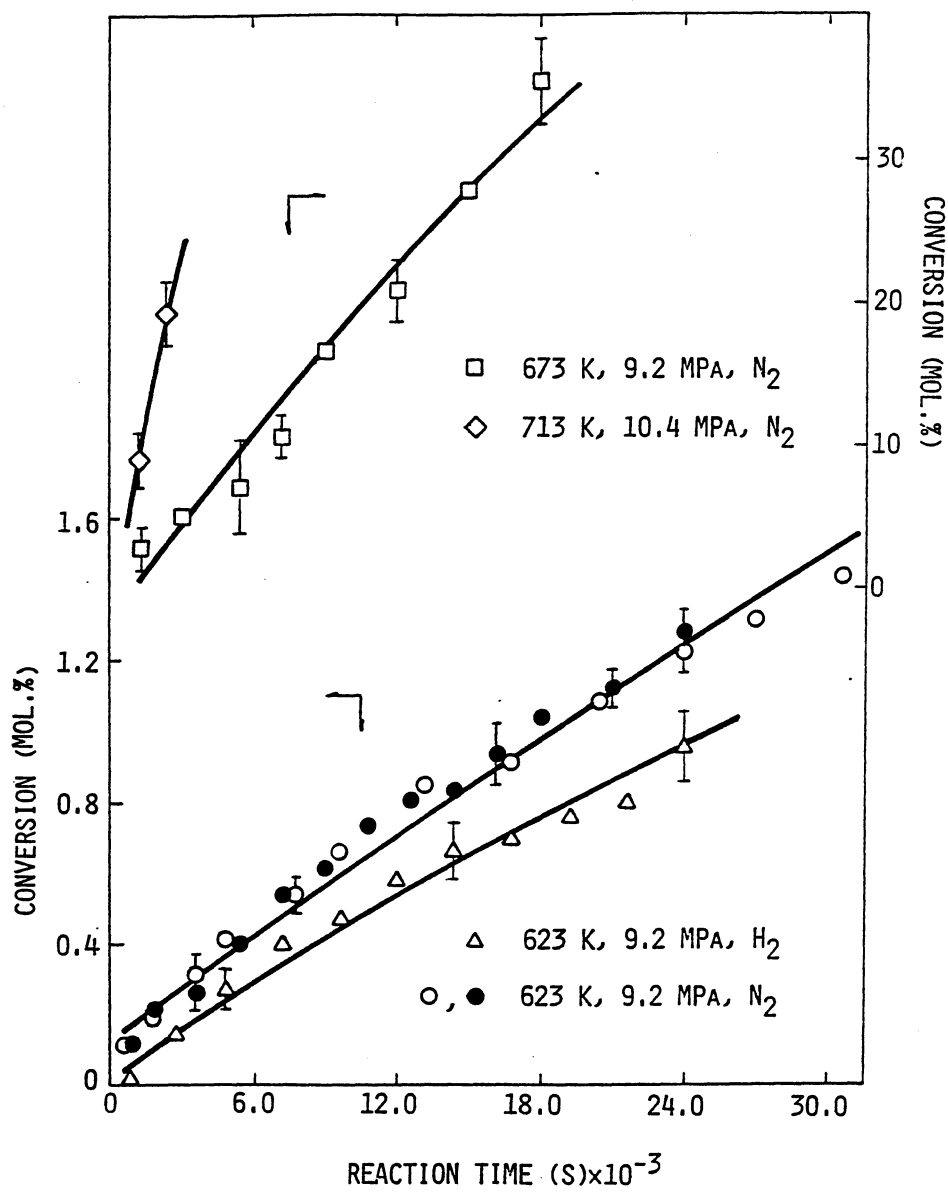

Figure 7. Dodecane Conversion under Various Conditions

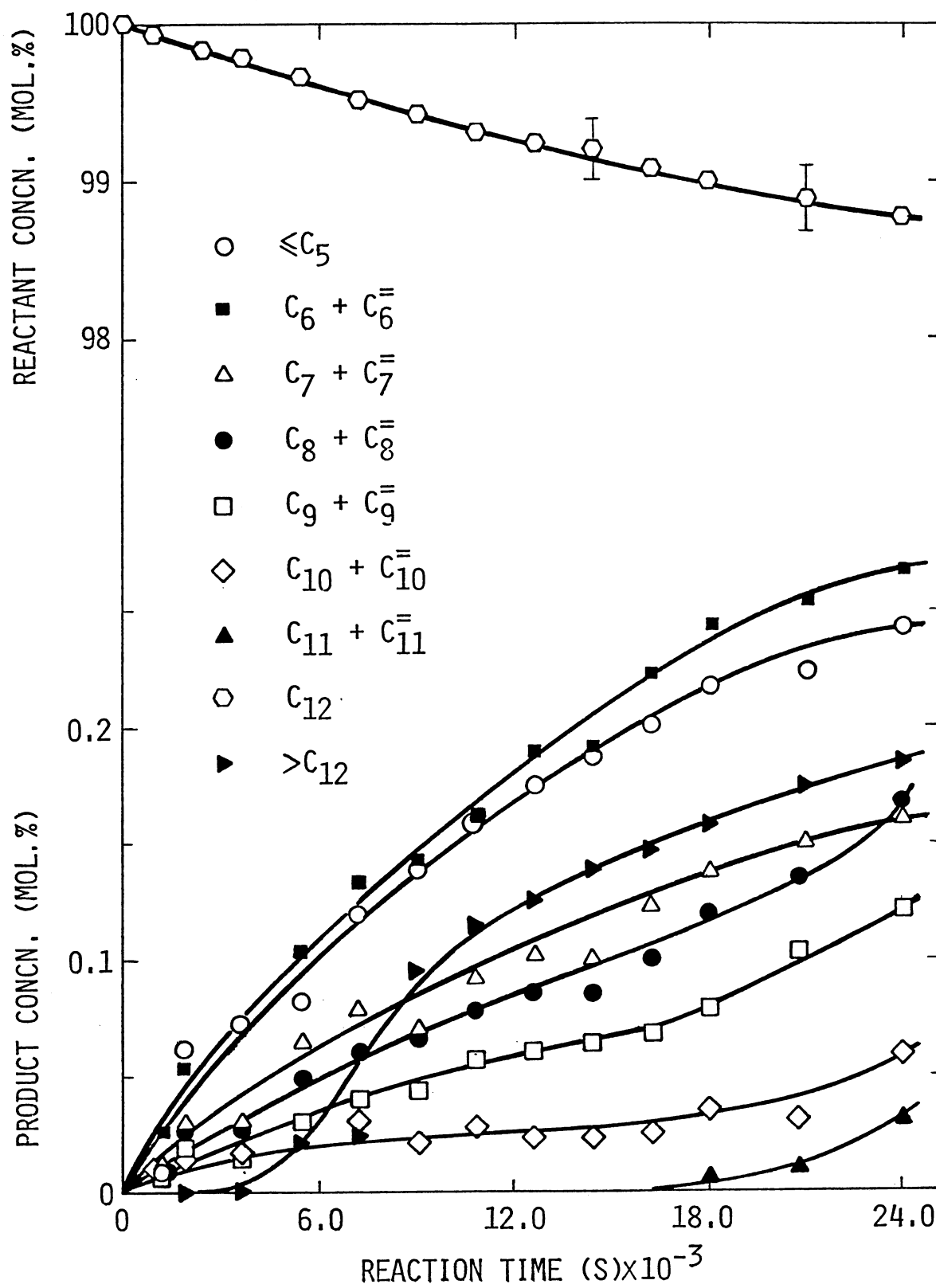

Figure 8. Product Distribution of Dodecane Thermolysis
(Run 12, $T=623$ K, $P=9.2$ MPa, N_2)

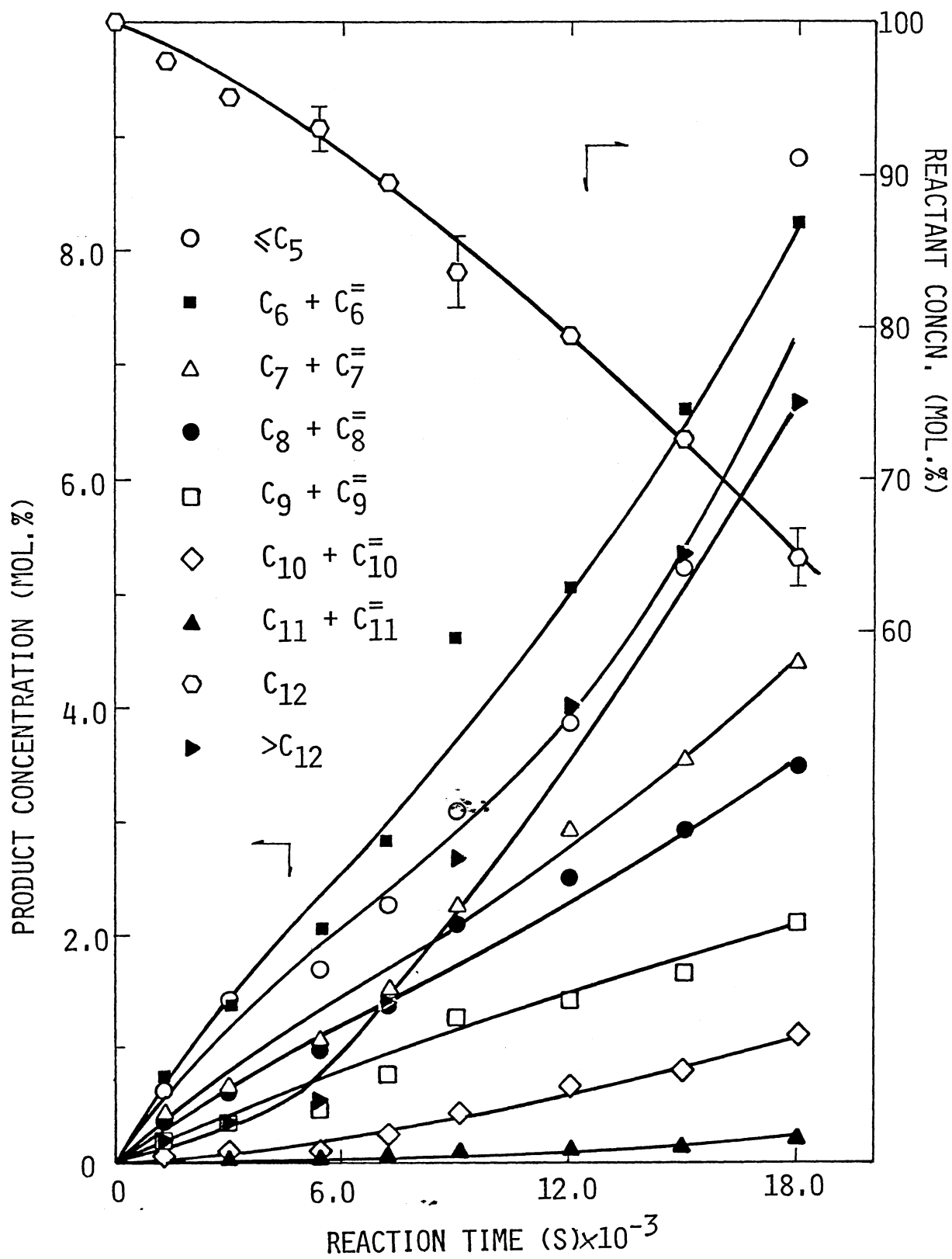

Figure 9. Product Distribution of Dodecane Thermolysis
(Run 13, $T=673$ K, $P=9.2$ MPa, N_2)

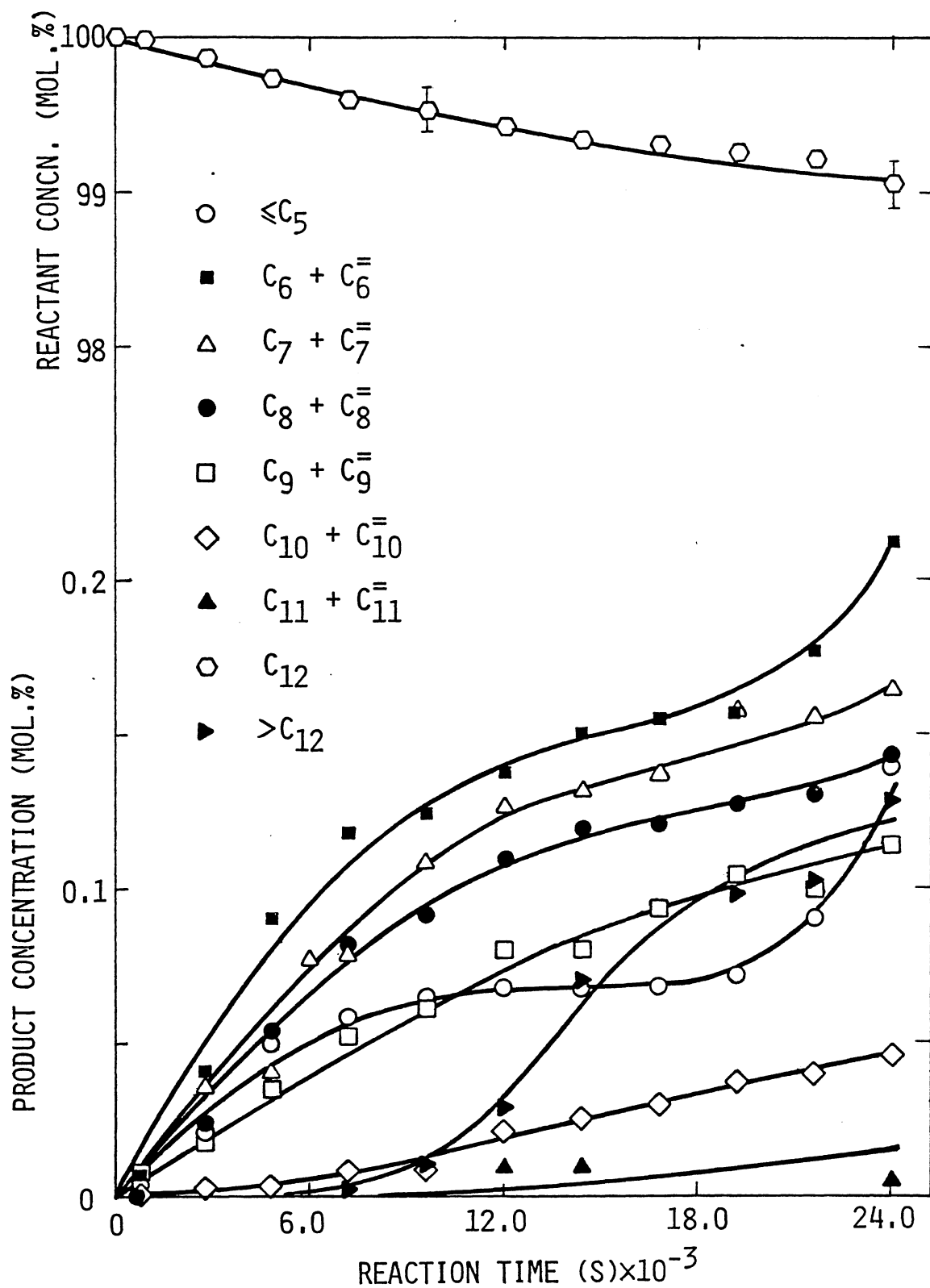

Figure 10. Product Distribution of Dodecane Thermolysis
(Run 14, $T=623$ K, $P=9.2$ MPa, H_2)

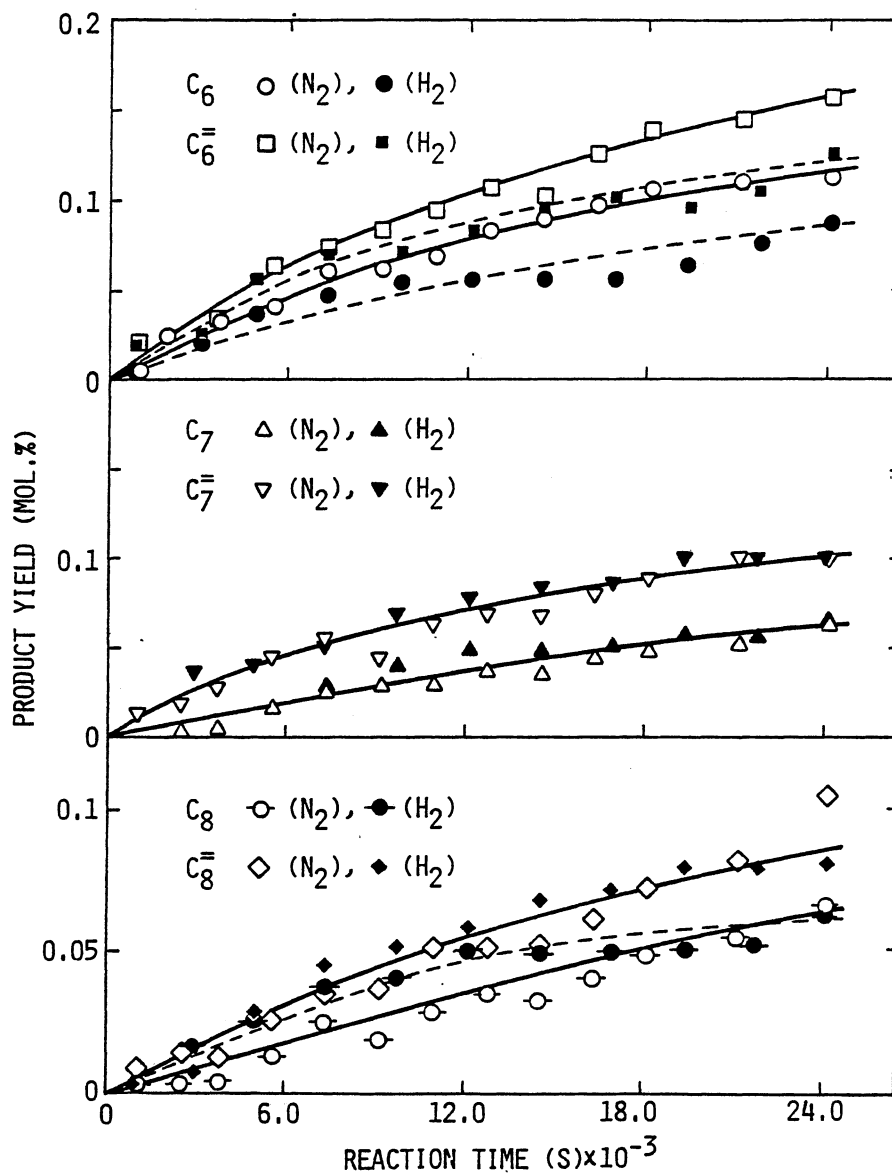

Figure 11a. Products from Dodecane Thermolysis
in Different Environments
($T=623$ K, $P=9.2$ MPa)

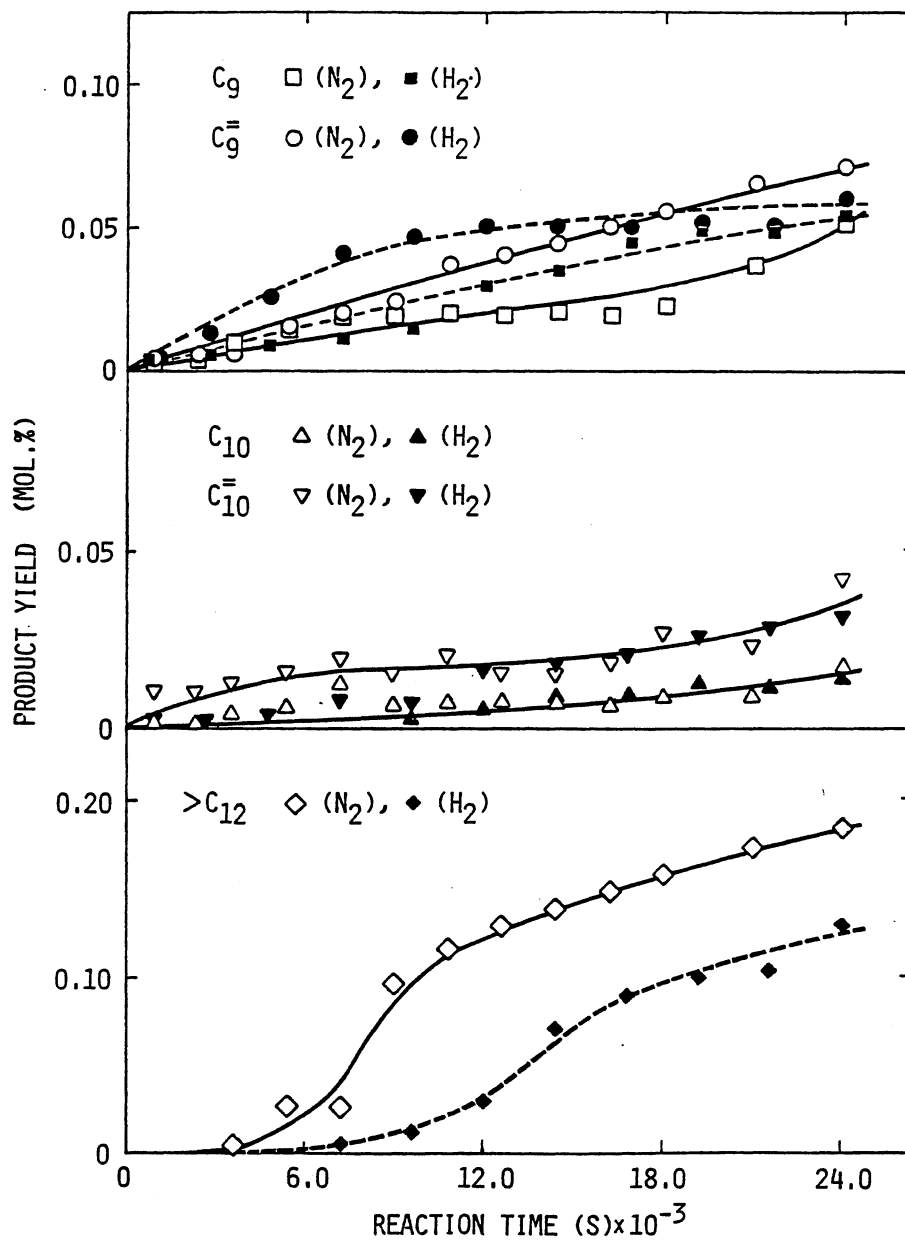

Figure 11b. Products from Dodecane Thermolysis
in Different Environments
(T=623 K, P=9.2 MPa)

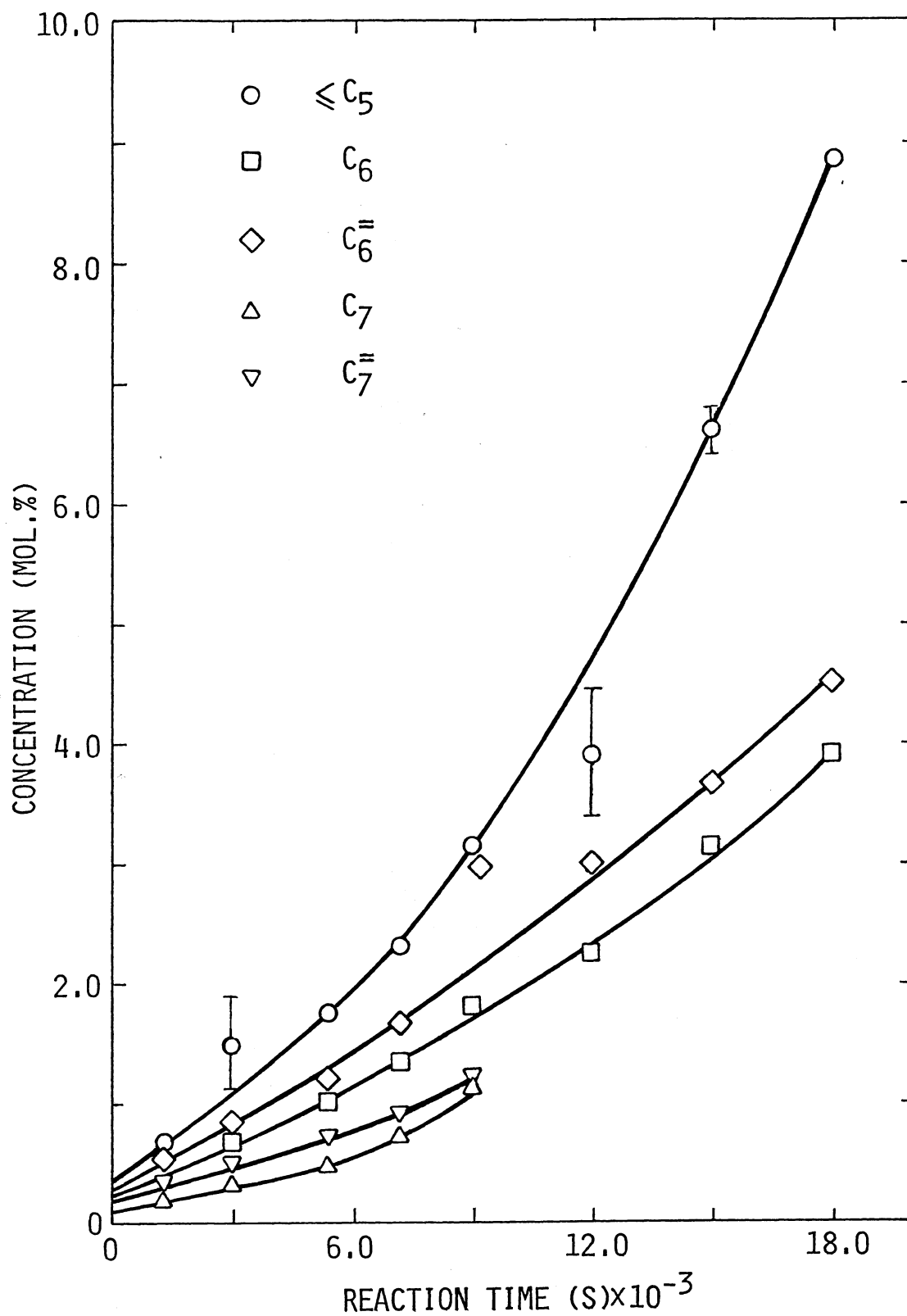

Figure 12. Paraffins and Olefins from Dodecane Thermolysis
($T=673$ K, $P=9.2$ MPa, N_2)

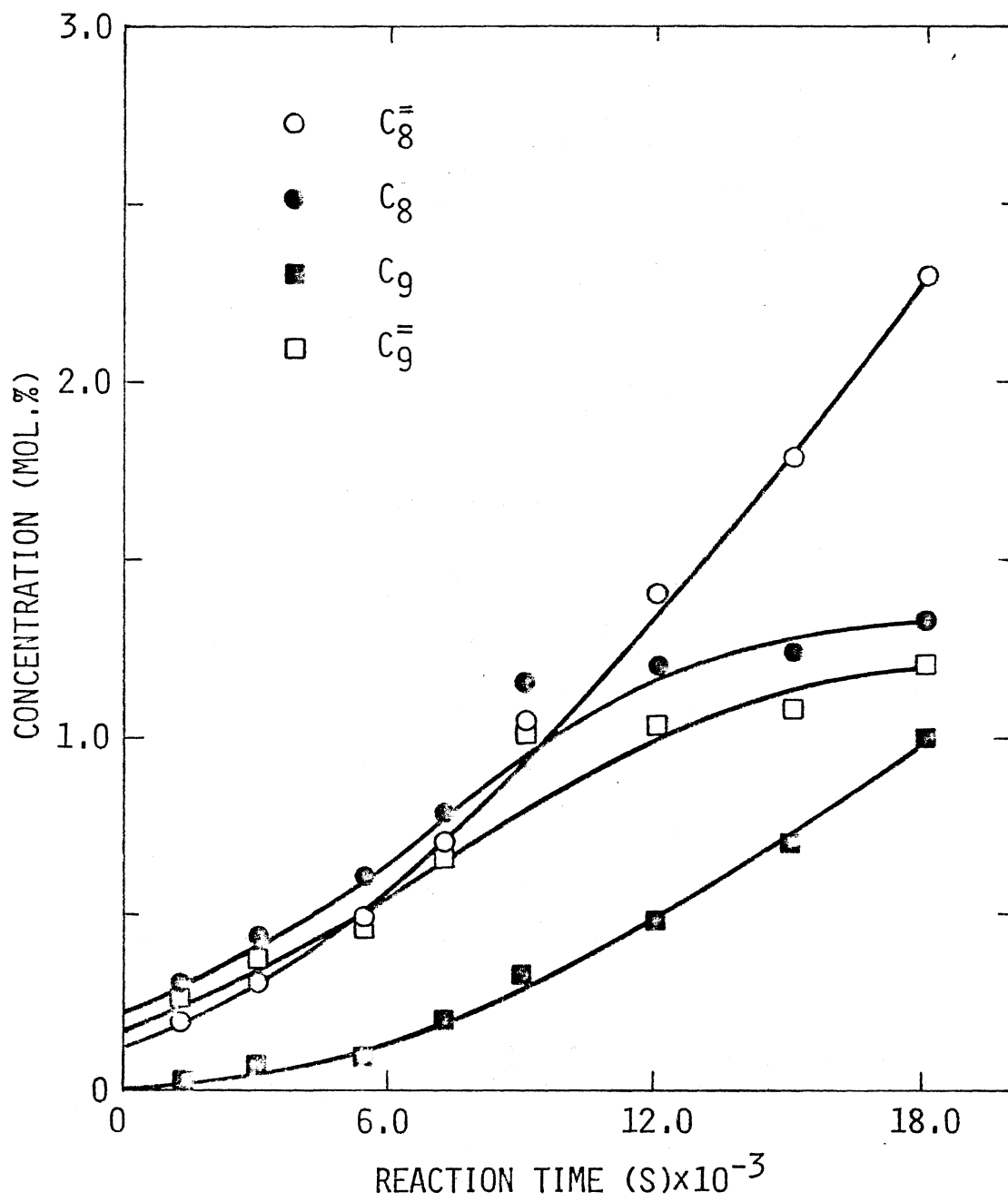

Figure 13. Paraffins and Olefins from Dodecane Thermolysis
(T=673 K, P=9.2 MPa, N₂)

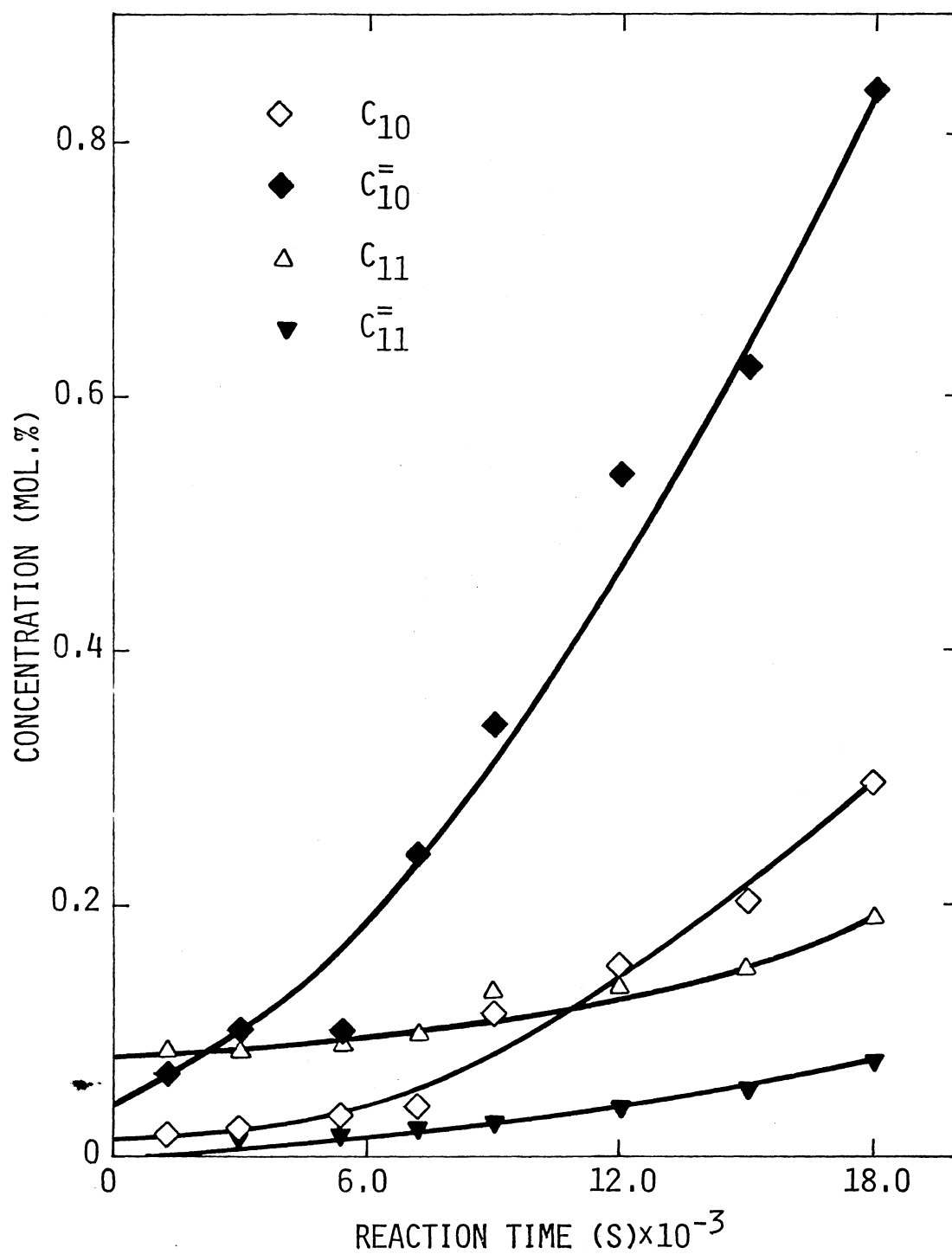

Figure 14. Paraffins and Olefins from Dodecane Thermolysis
($T=673$ K, $P=9.2$ MPa, N_2)

and 13, the $C_6 + C_6^-$ yields were far greater than the second high yields $C_7 + C_7^-$.

From Figures 11 to 14 which demonstrate the individual paraffins and olefins in the reaction liquid, essentially all olefins show higher yields than their paraffin counterparts.

Components heavier than the reactant dodecane are lumped together as $> C_{12}$ in the tables. The corresponding curves in Figures 8 to 10 all show a sharp deflection. Gas chromatograms indicated that the heaviest component was docosane. Interestingly, tridecane was not found in any samples analyzed by GC/MS.

Gas analysis results are plotted in Figures 15 and 16, for runs conducted at 623 K, 9.2 MPa, under either nitrogen or hydrogen. Corresponding data are listed in Table XXV (Appendix B).

These data reveal that ethane is the most abundant component in gas. When corresponding alkane and alkene are counted together, propane plus propylene is by far the most abundant, and the order is $C_3 + C_3^- > C_2 + C_2^- > C_1$. Another interesting and reasonable point is that essentially no olefins were found in the gas samples obtained from Run 14, which was conducted in a hydrogen environment.

No hydrocarbons heavier than propane were found in gas samples from Run 14, but some butane and butene(s) were observed in samples from Run 12. Substantial amounts of butane and butene(s) were present in samples obtained in Run 13, which may be attributed to higher reaction temperature and hence higher conversion. Pentane and pentene(s) were detected only in the sample collected at the 5 h reaction time of Run 13.

B. Thermolysis of o-Ethylphenol

Pure OEP thermolysis experiments were performed at the same temperature (623 K) and system pressure (9.2 MPa) but in different environments - N_2 or H_2 . The former was used in Run 15, and the latter in Run 16. Conversion and yield data are presented in Tables XXVI and XXVII, gas analysis results in Table XXVIII, and gas condensate analysis data in Table XXIX, all in Appendix B. These data are plotted in Figures 17 through 19, and Figure 20 is a representative chromatogram of the gas analysis.

Analytical results reveal that minor quantities of benzene, toluene, and ethylbenzene were produced during OEP thermolysis as a consequence of deoxy-genation. Cresols were also formed during the reaction as a result of demethylation. In addition, para and meta isomers of ethylphenol appeared, which must be products of isomerization. Essentially no xylenols were generated. Products heavier than xylenols were lumped together as "heavies". Obviously, phenol was the main product.

Gas analysis data show that ethane was the most abundant component in the gas, and ethane plus ethylene concentration is much higher than that of methane. No propane, propylene or heavier components were found.

Little difference was noticed between the results of thermolysis under the two environments (N_2 vs H_2).

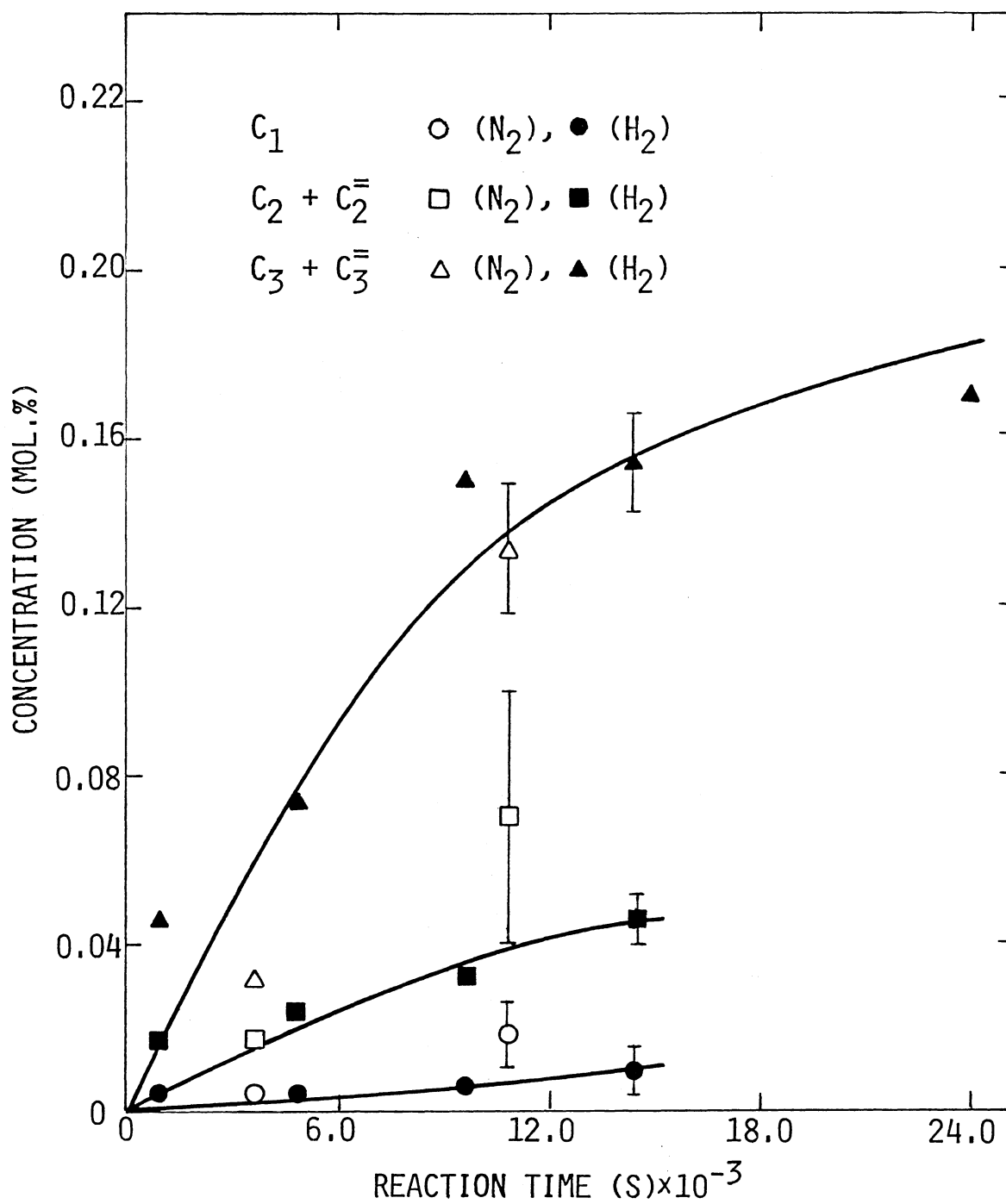

Figure 15. Gas Analysis for Dodecane Thermolysis
($T=623$ K, $P=9.2$ MPa)

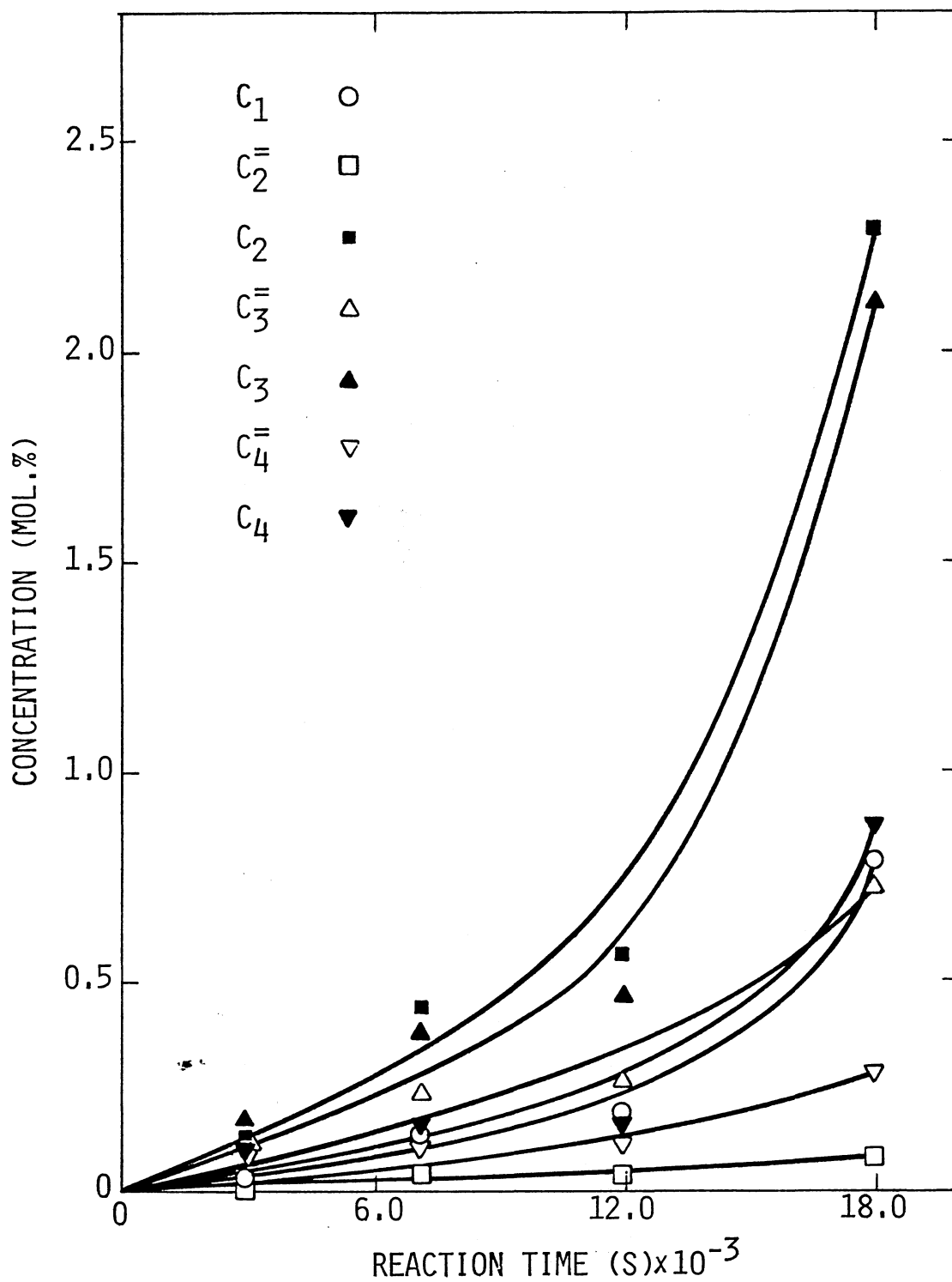

Figure 16. Gas Analysis for Dodecane Thermolysis
($T=673$ K, $P=9.2$ MPa, N_2)

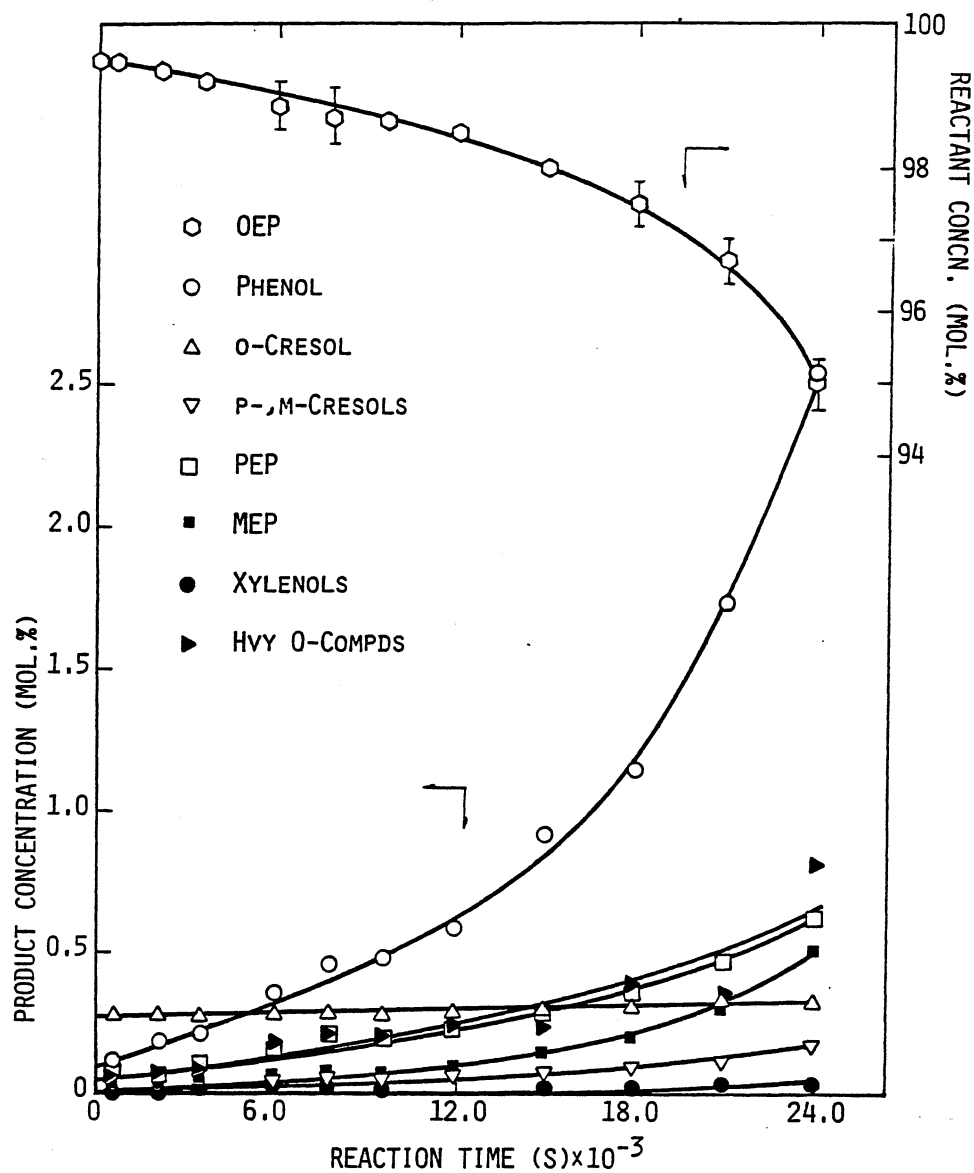

Figure 17. Product Distribution of o-Ethylphenol Thermolysis
(Run 15, T=623 K, P=9.2 MPa, N₂)

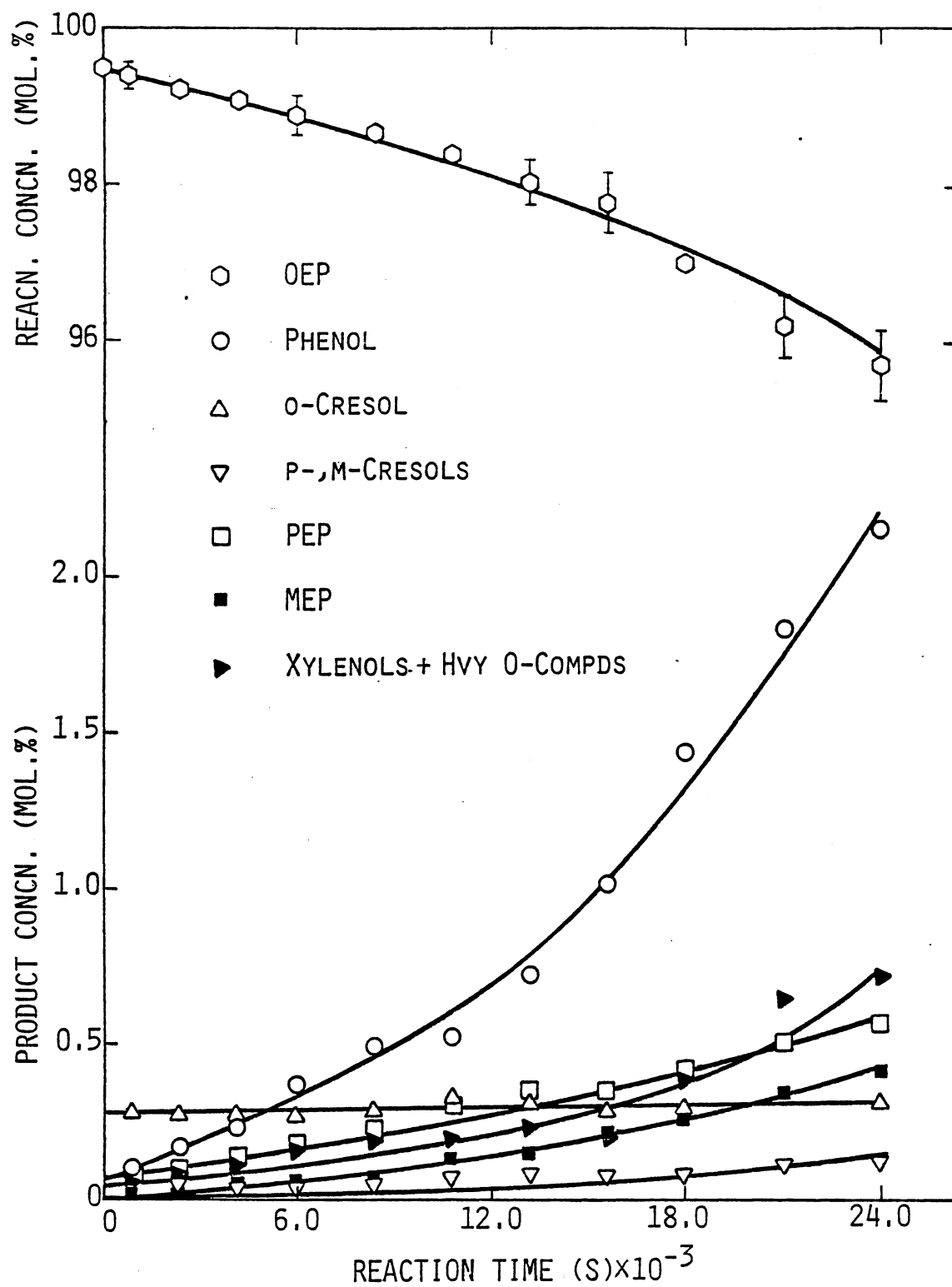

Figure 18. Product Distribution of *o*-Ethylphenol Thermolysis
(Run 16, T=623 K, P=9.2 MPa, H₂)

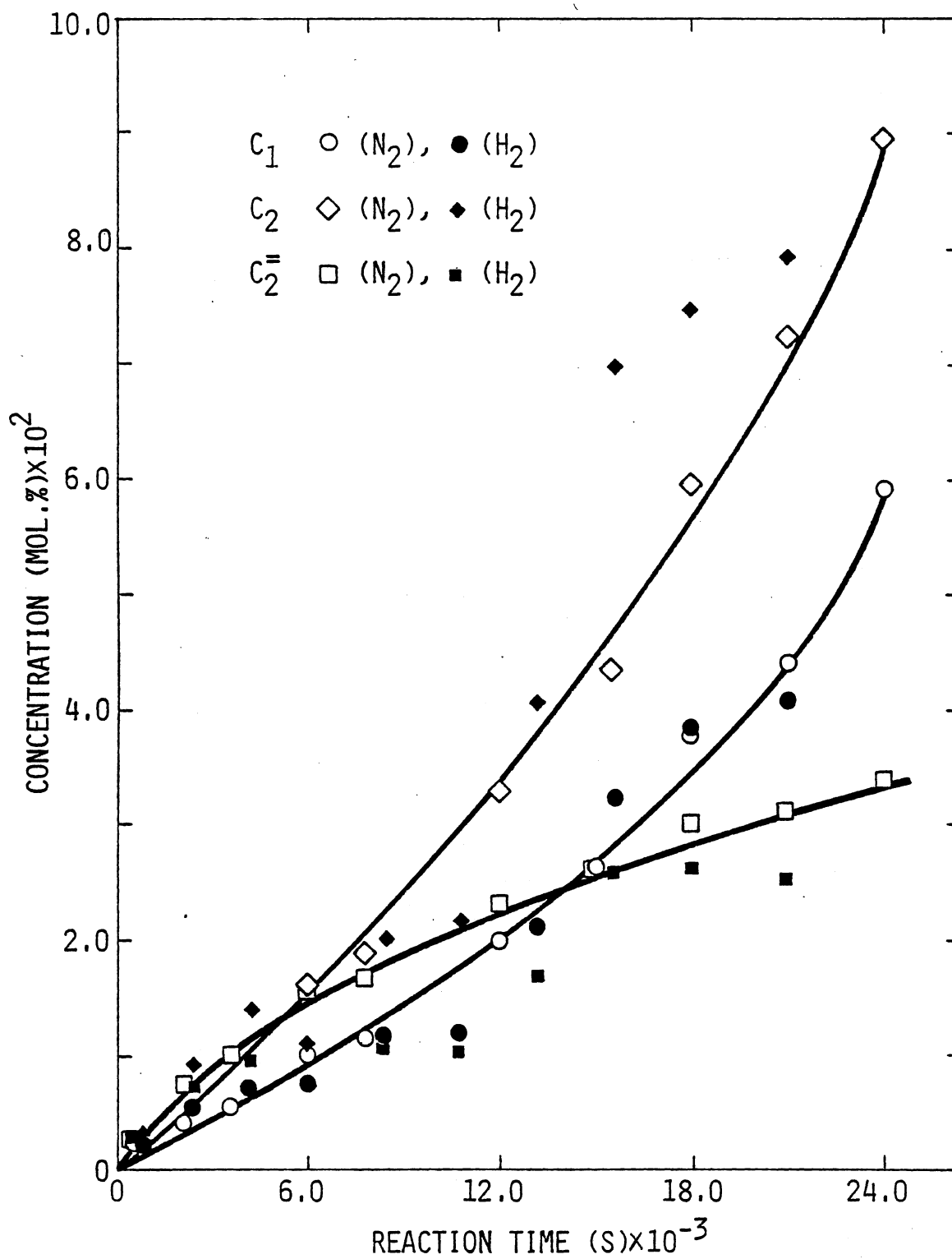
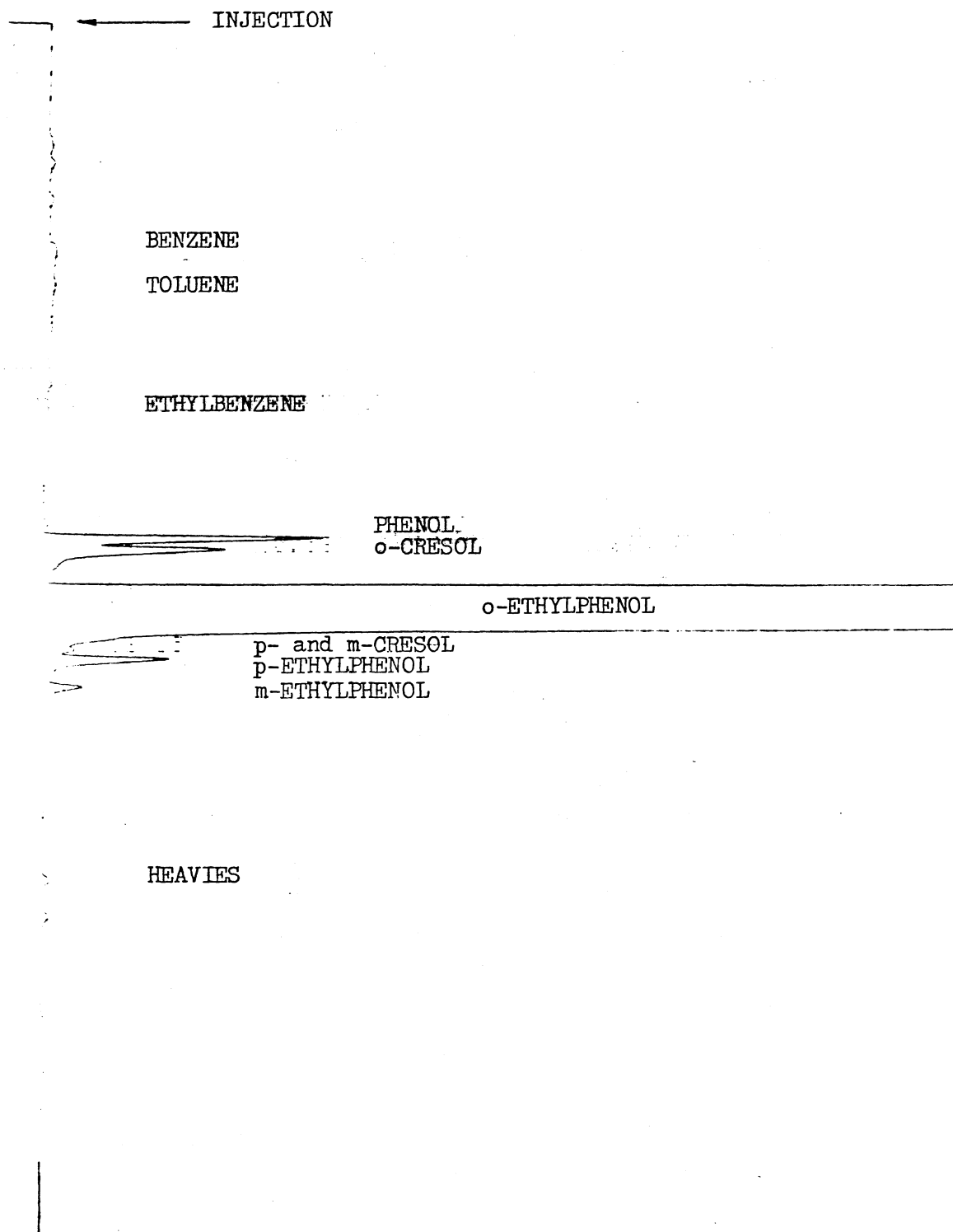

Figure 19. Gas Analysis for o-Ethylphenol Thermolysis
(T=623 K, P=9.2 MPa)

Figure 20. Typical Chromatogram for Liquid Samples from o-Ethylphenol Thermolysts (Run 15)



C. Thermolysis of o-Ethylphenol in Dodecane

Thermolysis experiments on OEP in the carrier solvent dodecane were carried out under various conditions. Results are presented in Tables XXX through XXXVIII (Appendix B).

C.1. Thermolysis of o-Ethylphenol in Dodecane under Nitrogen Atmosphere at 623 K

Runs No. 3 and 6 were carried out at 623 K and 9.2 MPa N₂. Experimental data are listed in Tables XXX and XXXI and plotted in Figures 21 and 22. A typical GC chromatogram is shown in Figure 23.

The composition of the liquid samples from thermolysis of OEP-dodecane solution is very much complicated. These liquids are mixtures of products of thermolytic reactions of both the solute and the solvent. Reaction products of the latter, although in small amounts at the reaction temperature of 623 K and a period of 3-7 h, insert definite influence on OEP cracking, as will be discussed later. The reverse is also true.

On account of the complexity, the analytical data of liquid products are divided into two groups: hydrocarbons and oxygen compounds, and listed in separate tables. Some compounds that existed in pure dodecane and OEP cracking also appear here. Small amounts of benzene, toluene and xylenes were formed. They are grouped into the list of oxygen compounds since they must be deoxygenation products under present conditions. One complicating factor is that some hydrocarbons, being heavier than dodecane, are eluted in the ranges of xylenols and heavier oxygen compounds. No attempt was made to separate and determine

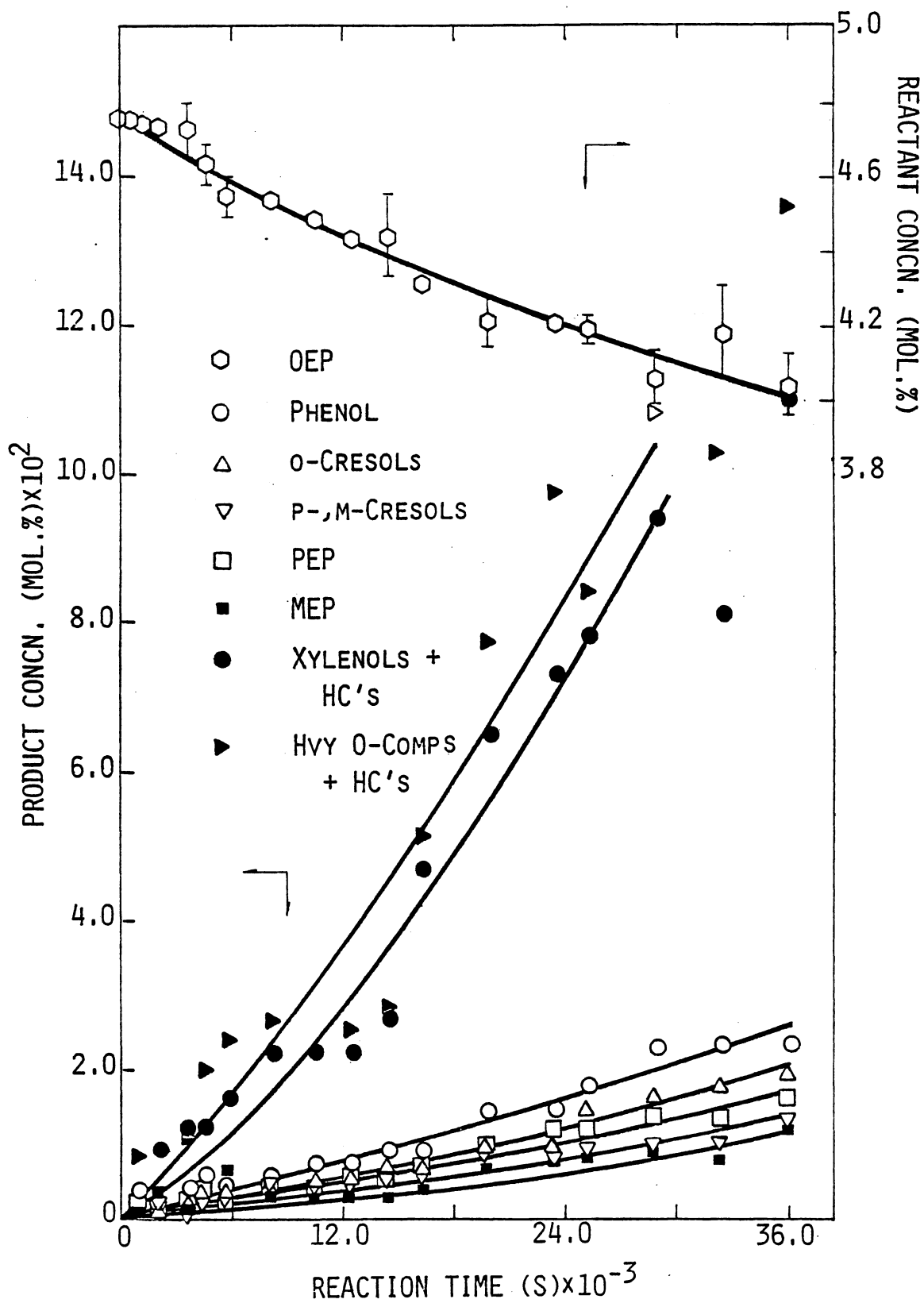

Figure 21. Product Distribution of o-Ethylphenol Thermolysis in Dodecane (Run 3, $T=623$ K, $P=9.2$ MPa, N_2)

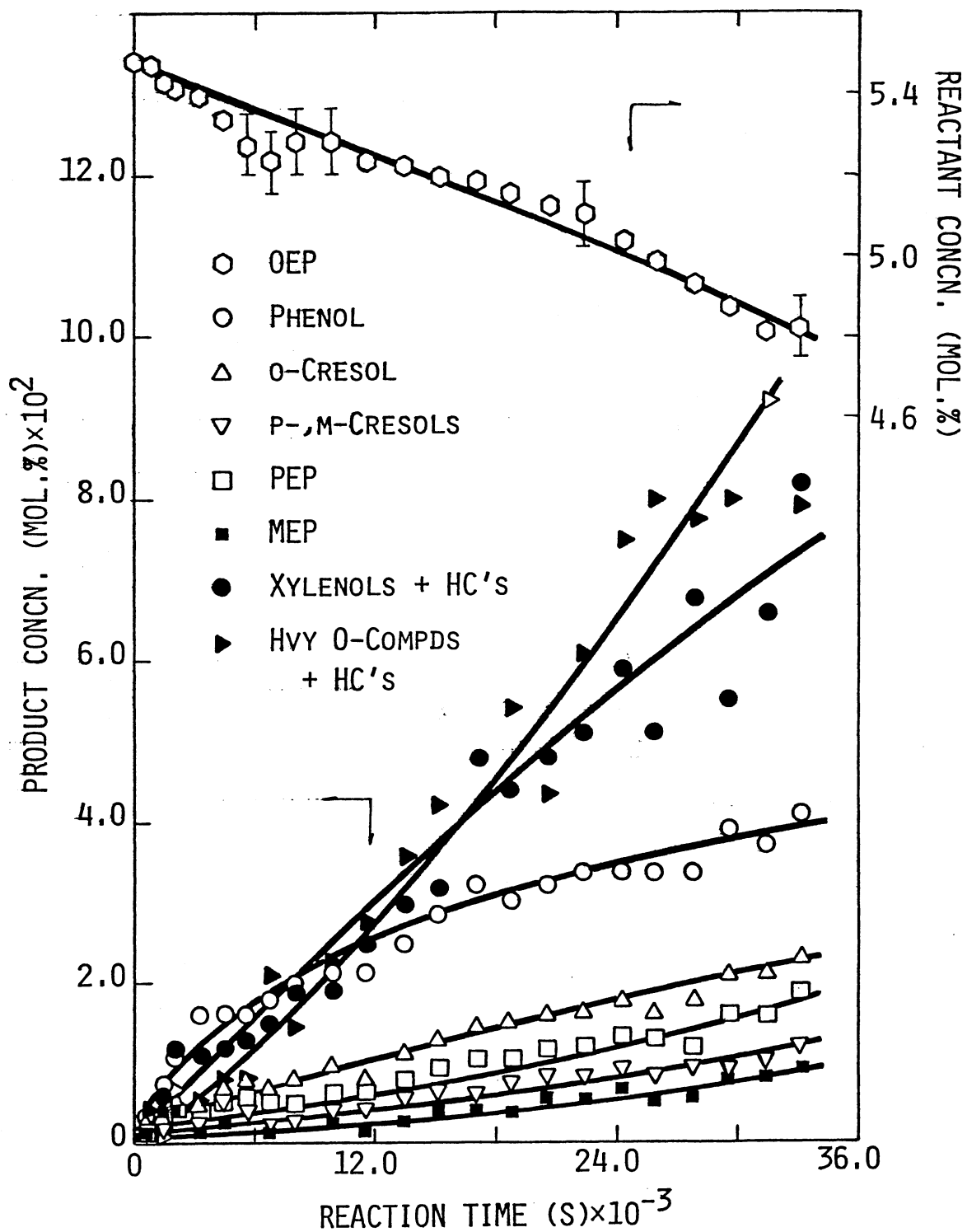
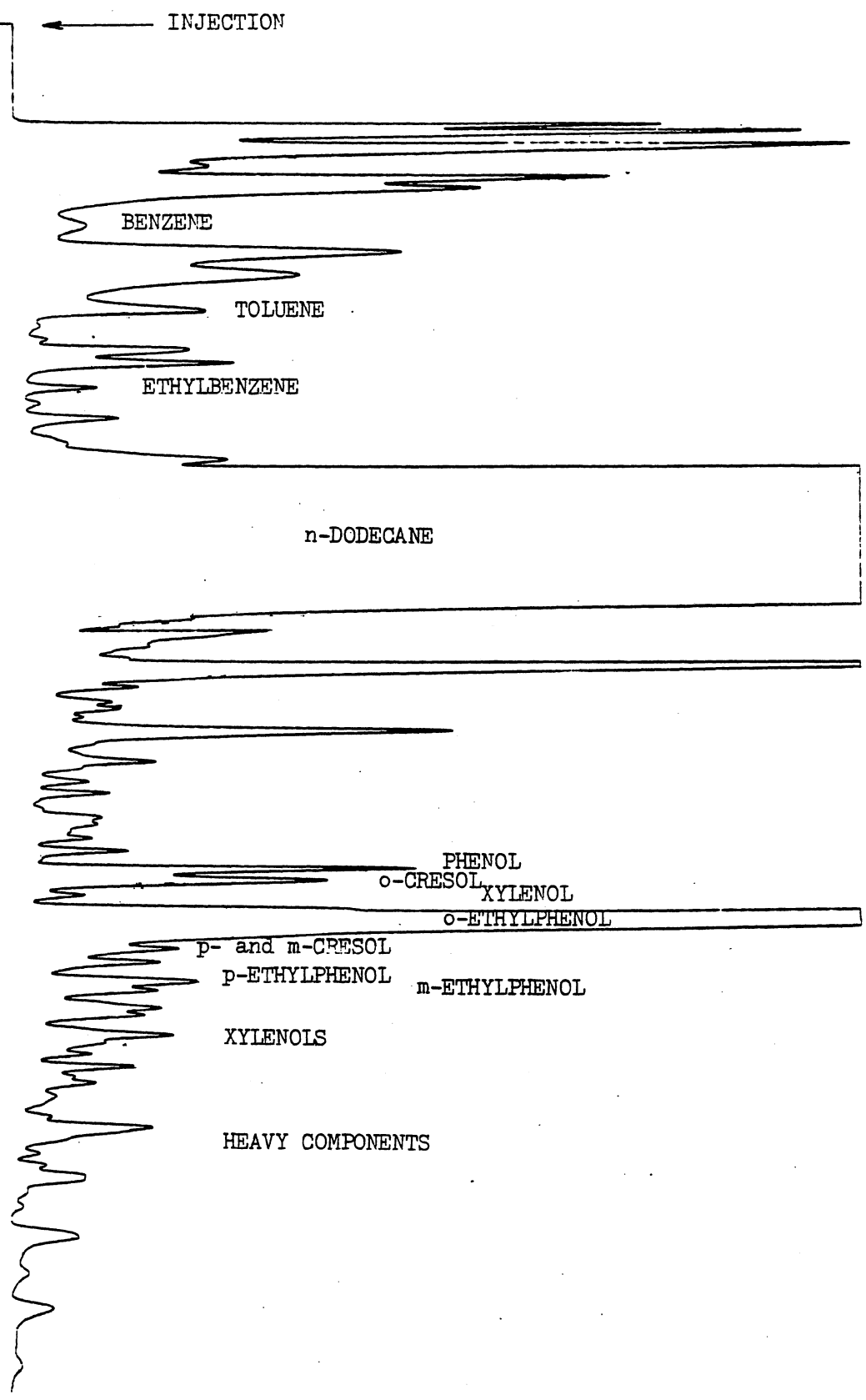

Figure 22. Product Distribution of o-Ethylphenol Thermolysis in Dodecane (Run 6, T=623 K, P=9.2 MPa, N₂)

Figure 23. Typical Chromatogram for Liquid Samples from o-Ethylphenol Thermolysis in Dodecane (Run 4)



them and they are lumped together as xylenol plus heavier hydrocarbons, and heavy oxygen compounds plus heavy hydrocarbons.

As regards hydrocarbon products, product distribution was similar to that observed in pure solvent decomposition. A decreasing trend in molar concentration with increasing hydrocarbon molecular weight is also clear.

By far the highest yield of phenol was observed in pure OEP thermolysis, isomerization products of ethylphenol were next prominent, with even less cresols, and deoxygenation products appeared only in slight amounts. While being thermolyzed concurrently with dodecane, OEP gave comparable amounts of various oxygen compounds. Yields of the aromatics were also relatively increased. Hence, different product distribution patterns were obtained for OEP thermolysis with or without the presence of the solvent.

The cracked gas of pure OEP has only methane, ethylene and ethane as its components, while that of OEP in dodecane thermolysis contains components heavier than ethane, i.e. propane, propylene, butane and butylene; these are definitely attributed to dodecane cracking. If only methane, ethylene, and ethane are considered, the last one is the most abundant in both cases, but cocracking of OEP and dodecane gives much less ethylene. This can be interpreted by means of free radical mechanism discussed in the next chapter.

C.2. Thermolysis of o-Ethylphenol in Dodecane under Differing Conditions

By factorial design, thermolysis experiments on OEP in dodecane at 623, 648 and 673 K, and pressures of 9.2, 7.0 and 4.7 MPa of nitrogen

were conducted. Results are tabulated in Tables XXX to XXXV and plotted in Figures 24-27.

High temperature seems to favor the formation of the cresols, giving distinctly high concentration of o-cresol and comparatively high concentrations of meta and para cresols in 673 K run. Also noticed is the relatively abundant amounts of heavier components, mostly xylene and heavier oxygen compounds, which must be condensation products.

Unlike the temperature, pressure seems to have no significant effect on the kinetics of OEP thermolysis. This is obvious from the comparison between 623 K runs No. 6 (9.2 MPa) and No. 9 (4.7 MPa), both under nitrogen atmosphere, and the comparison between two 673 K runs, No. 4 (9.2 MPa) and No. 5 (7.0 MPa), both in the same environment - nitrogen.

C.3. Thermolysis of o-Ethylphenol in Dodecane in Hydrogen Atmosphere

Also performed were experiments on OEP thermolysis in the same carrier solvent at 623 K and 9.2 and 15.6 MPa but in hydrogen. These are Runs 10, 21 and 20. Runs 10 and 21 are duplicates that were carried out at different dates several months apart. Since hydrogen usually shows its influence at relatively high pressures, the 15.6 MPa pressure was chosen for Run 20. Relevant data are summarized through Tables XXXVI to XXXVIII and also shown in Figures 28 to 30.

One thing is clear from the comparison between runs conducted in different environments - N_2 and H_2 . Runs performed in hydrogen (Nos. 10 and 21) showed lower conversions of OEP. Due to the low concentrations of oxygen products in these two experiments, relative analytical error

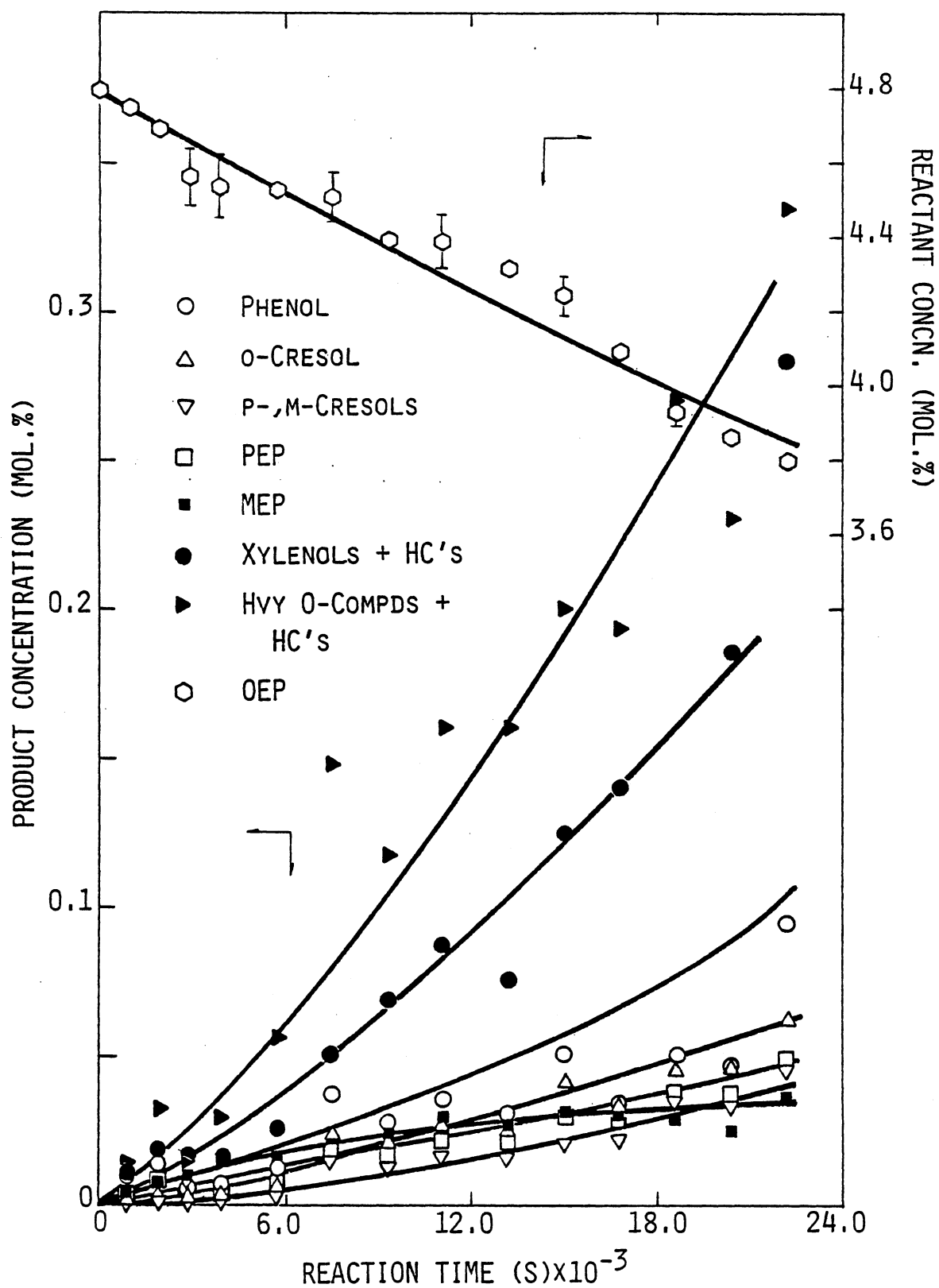

Figure 24. Product Distribution of o-Ethylphenol Thermolysis in Dodecane (Run 8, $T=648$ K, $P=9.2$ MPa, N_2)

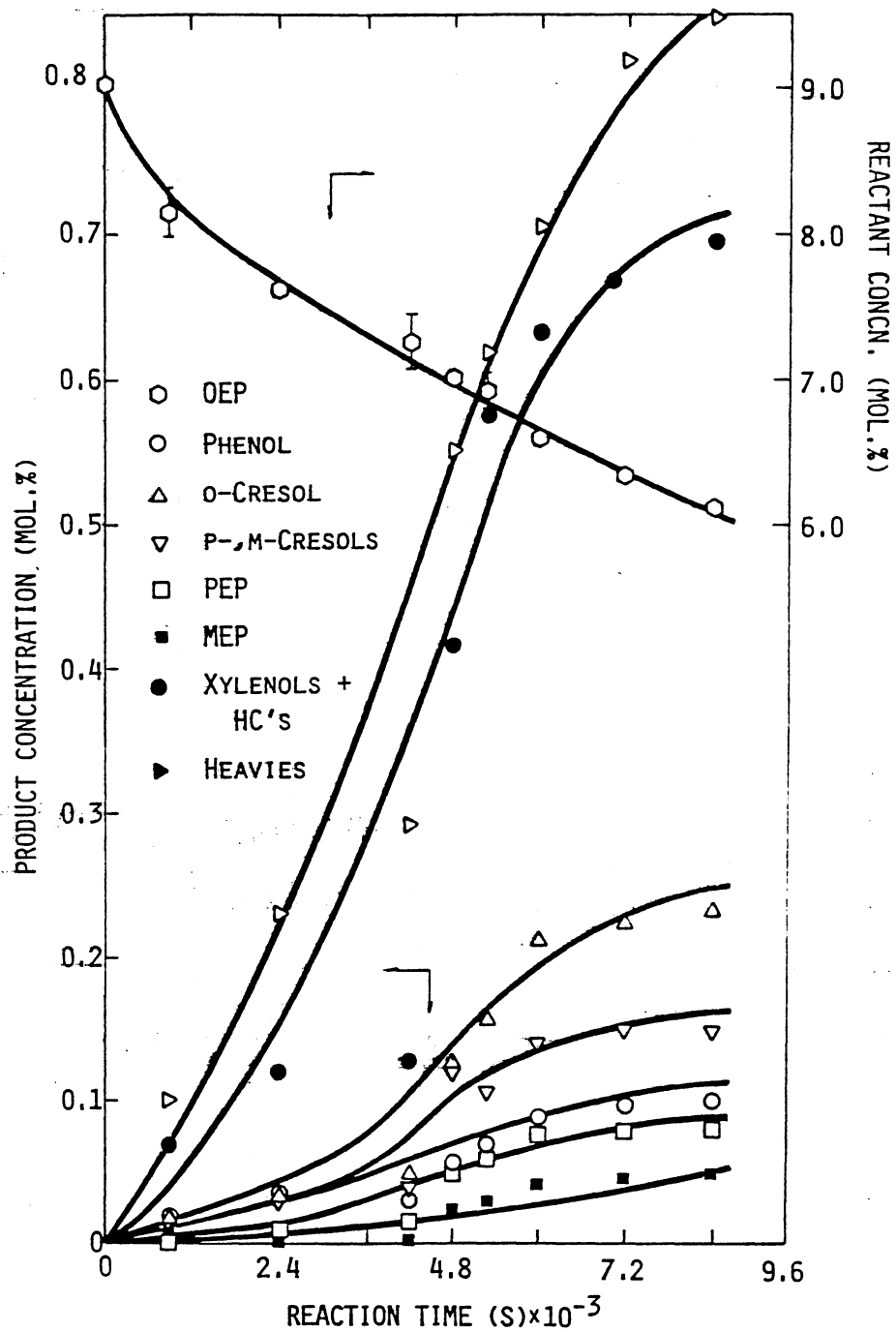

Figure 25. Product Distribution of o-Ethylphenol Thermolysis in Dodecane (Run 4, T= 673 K, P=9.2 MPa, N₂)

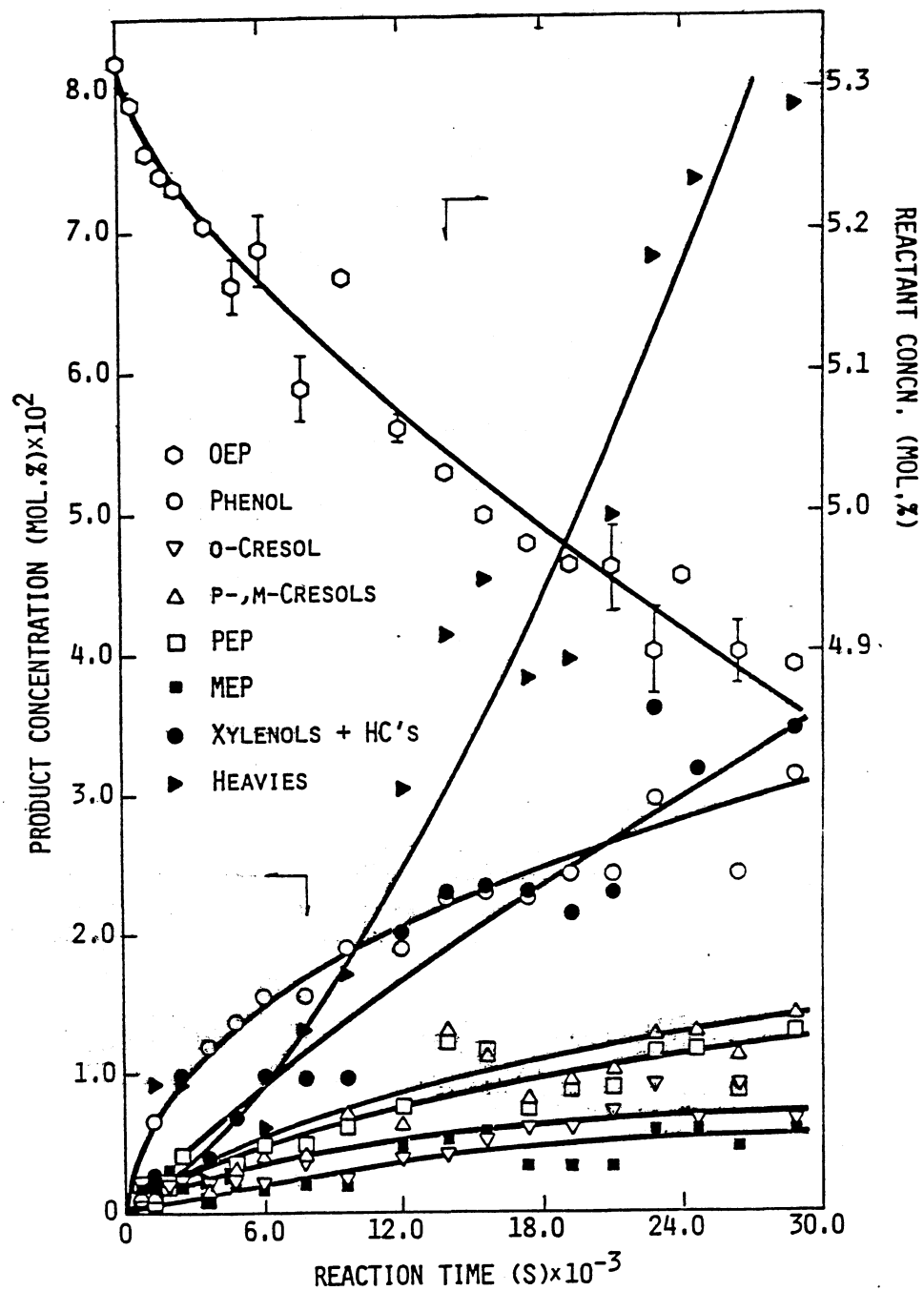

Figure 26. Product Distribution of o-Ethylphenol Thermolysis in Dodecane (Run 5, T= 673 K, P=7.0 MPa, N₂)

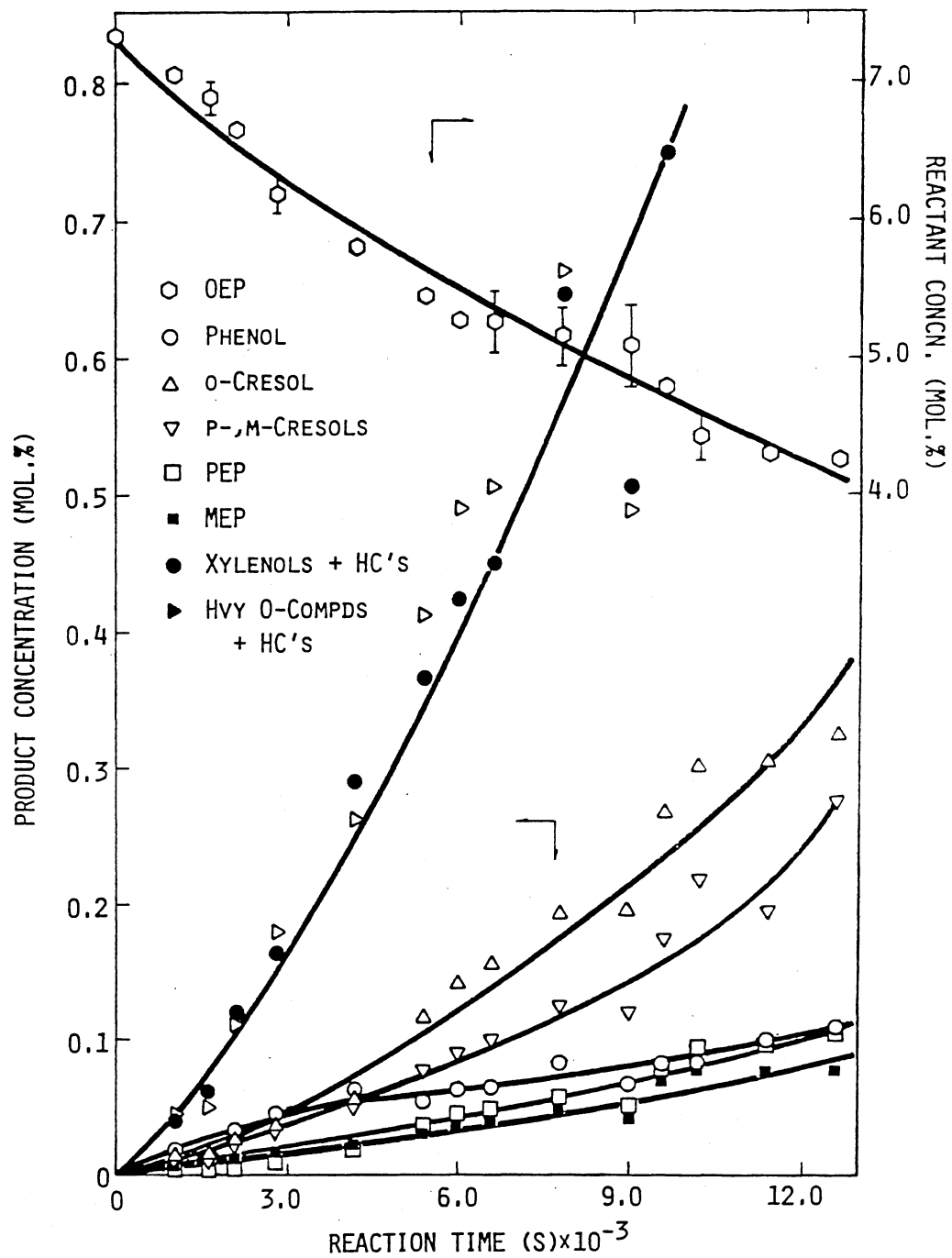

Figure 27. Product Distribution of o-Ethylphenol Thermolysis in Dodecane (Run 9, T= 623 K, P=4.7 MPa, N₂)

should be higher. However, except for the aromatics and *m*-ethylphenol, the consistency between these two runs is reasonable. An obvious fact is that para and meta cresols did not show up. Furthermore, formation of condensation products appeared to be more suppressed.

In Run 20, negligible amount of *o*-cresol appeared in the liquid while its para and meta isomers, as well as xylenols, disappeared completely. Almost no heavy compounds, hydrocarbon or oxygen-containing, were found. This is discussed further in the following chapter.

Gas analysis data of Runs 5, 21 and 20 are listed in Table XXXIX.

D. Thermolysis of Para and Meta Ethylphenols in Dodecane

Experimental run No. 17, thermolysis of PEP in solvent, was done at 623 K and 9.2 MPa N₂. Its conversion and yield data are recorded in Table XL and Figure 31.

Two experiments on MEP thermolysis in solvent were carried out at 623 K and 9.2 MPa, but under different environments, nitrogen and hydrogen. They are Runs 18 and 19. Corresponding data are presented in Tables XLI and XLII and in Figures 32 and 33.

Selected liquid samples from Runs 17 through 21 were also analyzed by means of GC/MS. Oxygen-containing compounds, such as the three isomeric ethylphenols, three cresol isomers, phenol, xylenols (mostly 2,4-xyleneol), 2- and 4-propylphenols, were detected. Hydrocarbons heavier than dodecane were also identified - C₁₄, C₁₅, C₁₆, C₁₇, C₁₈ and C₁₉. Tridecane again was not found in any samples analyzed.

Gas analysis data are tabulated in Table XLIII.

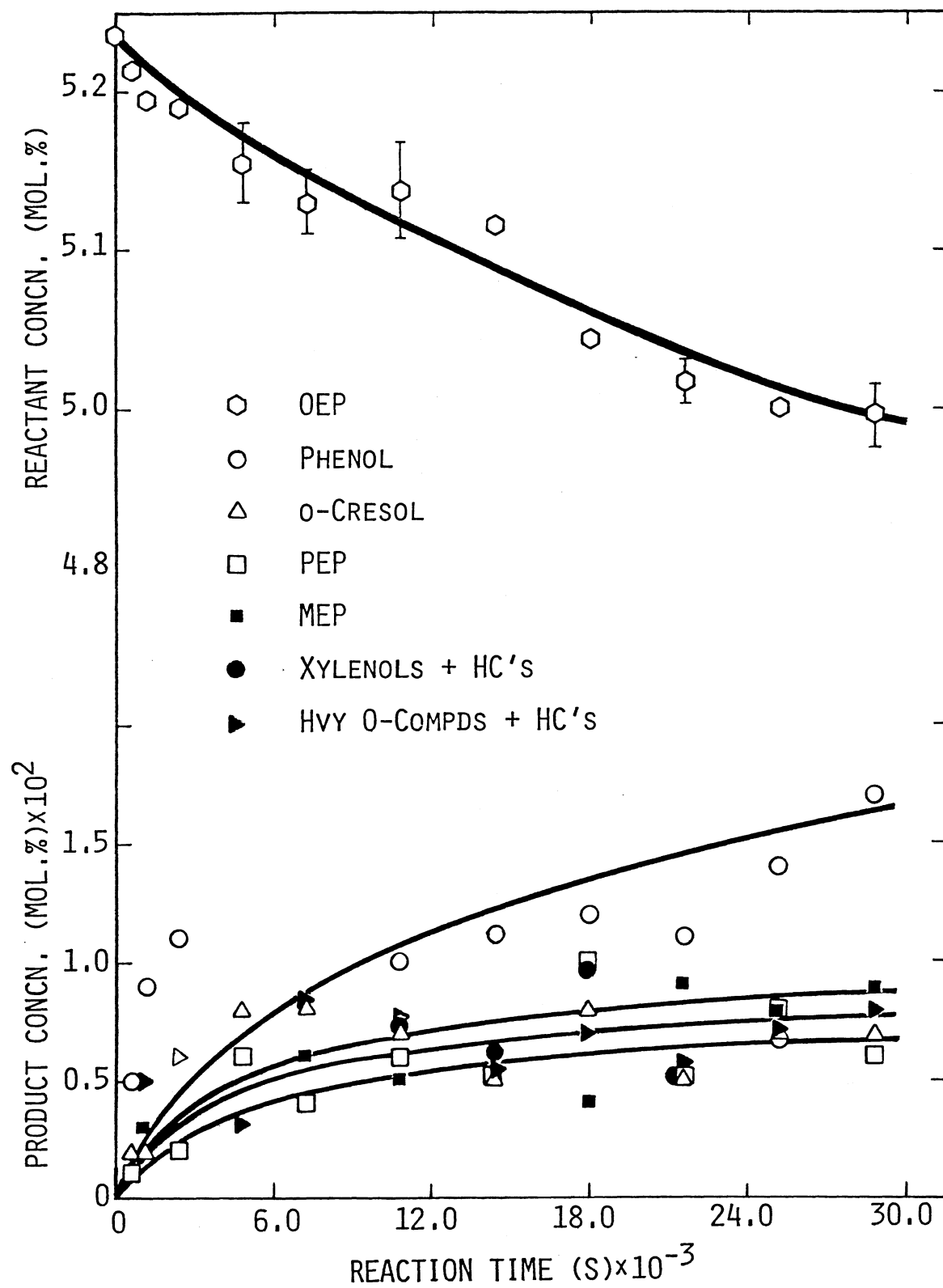

Figure 28. Product Distribution of *o*-Ethylphenol Thermolysis in Dodecane (Run 10, $T=623$ K, $P=9.2$ MPa, H_2)

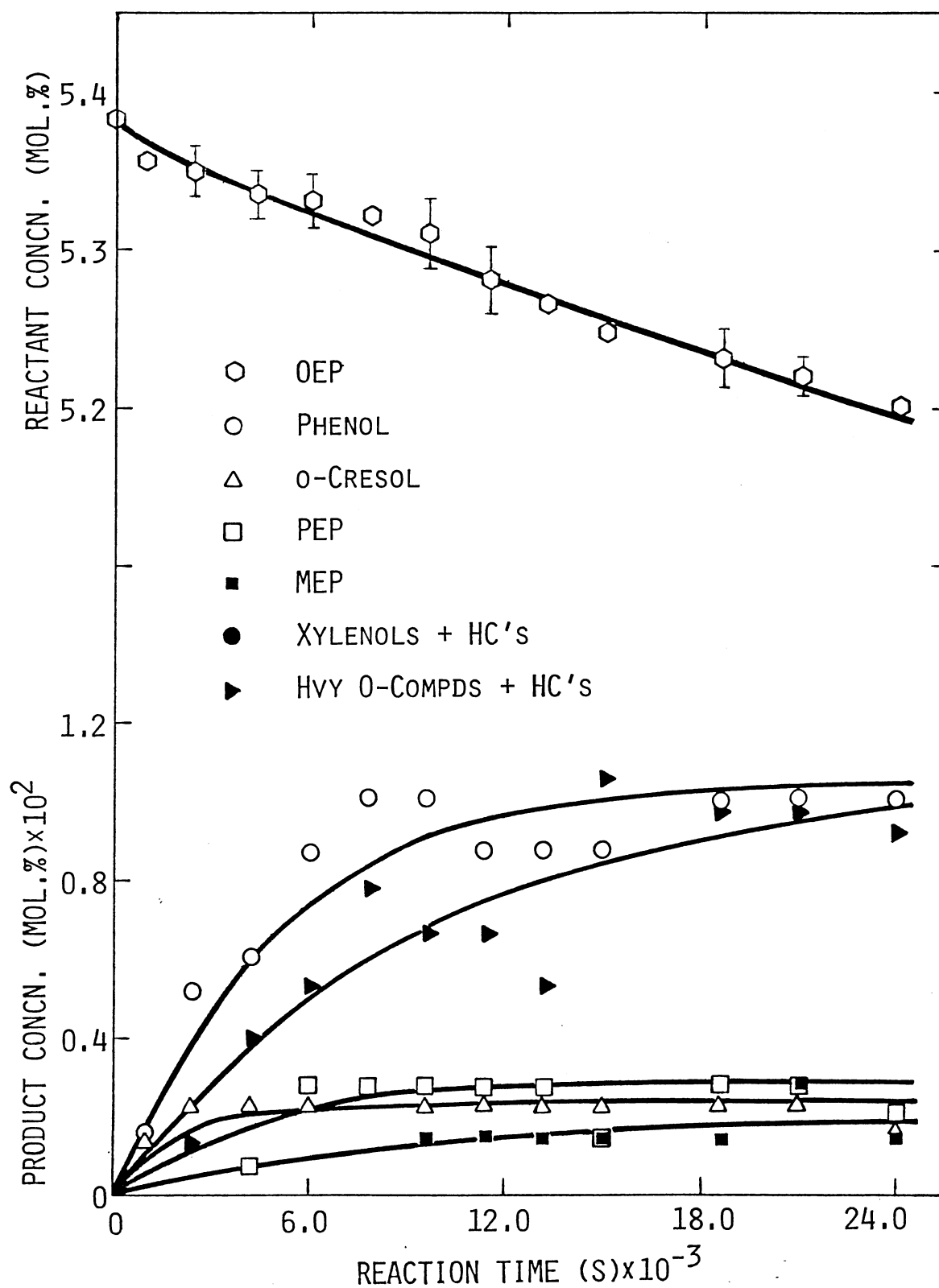

Figure 29. Product Distribution of o-Ethylphenol Thermolysis in Dodecane (Run 21, T=623 K, P=9.2 MPa, H₂)

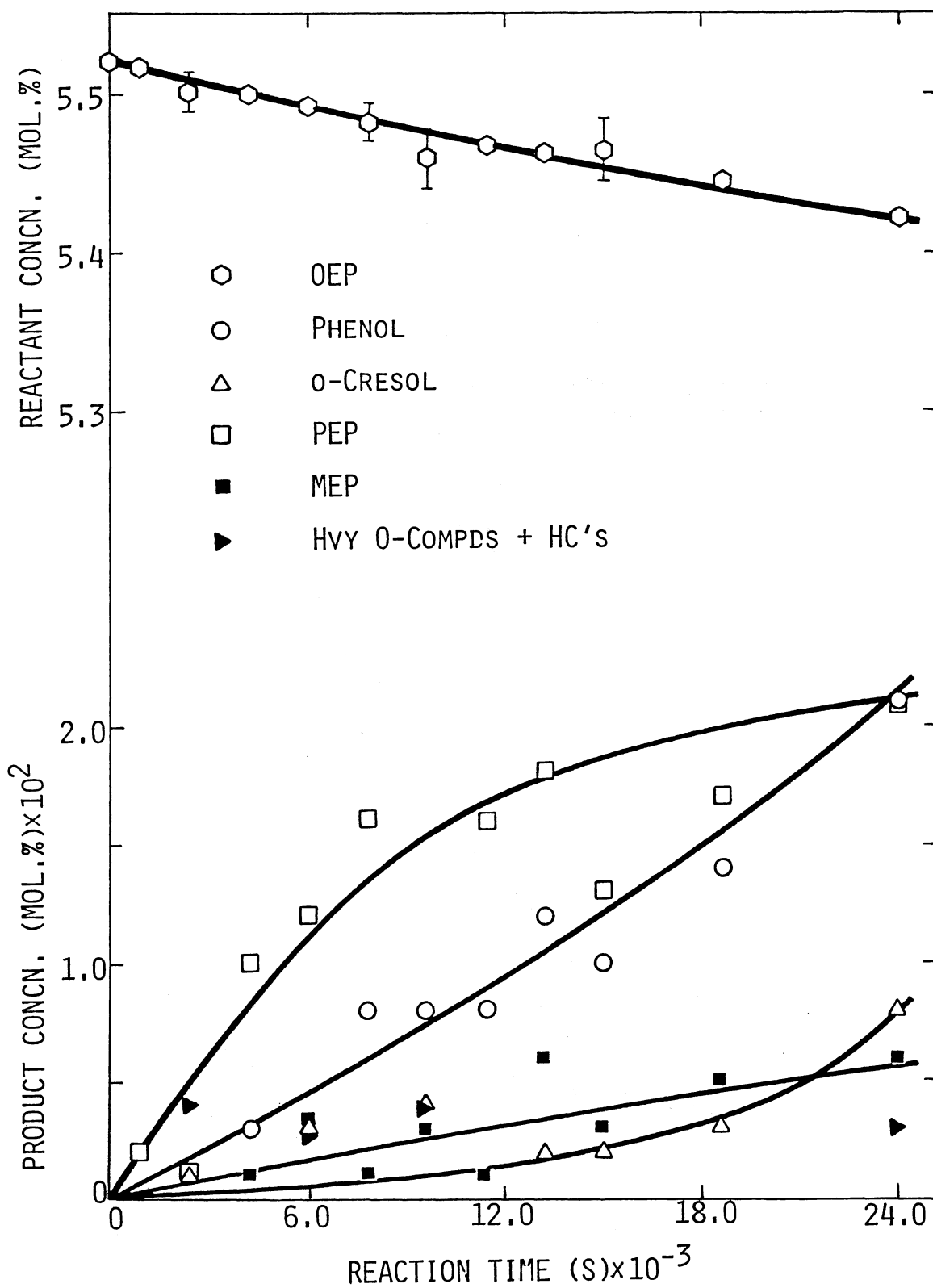

Figure 30. Product Distribution of o-Ethylphenol Thermolysis in Dodecane (Run 20, T=623 K, P=9.2 MPa, H₂)

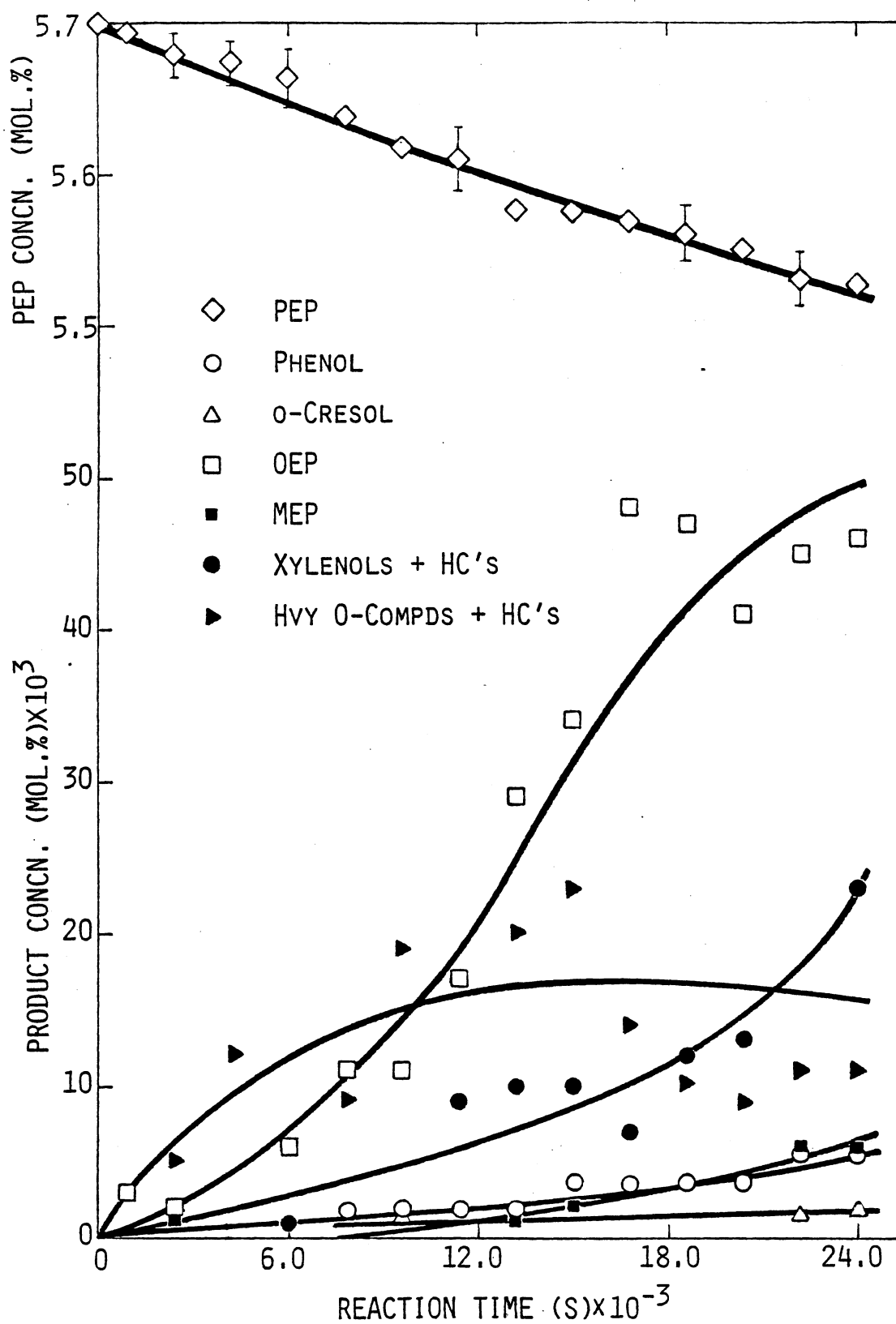

Figure 31. Product Distribution of p-Ethylphenol Thermolysis in Dodecane (Run 17, T=623 K, P=9.2 MPa, N₂)

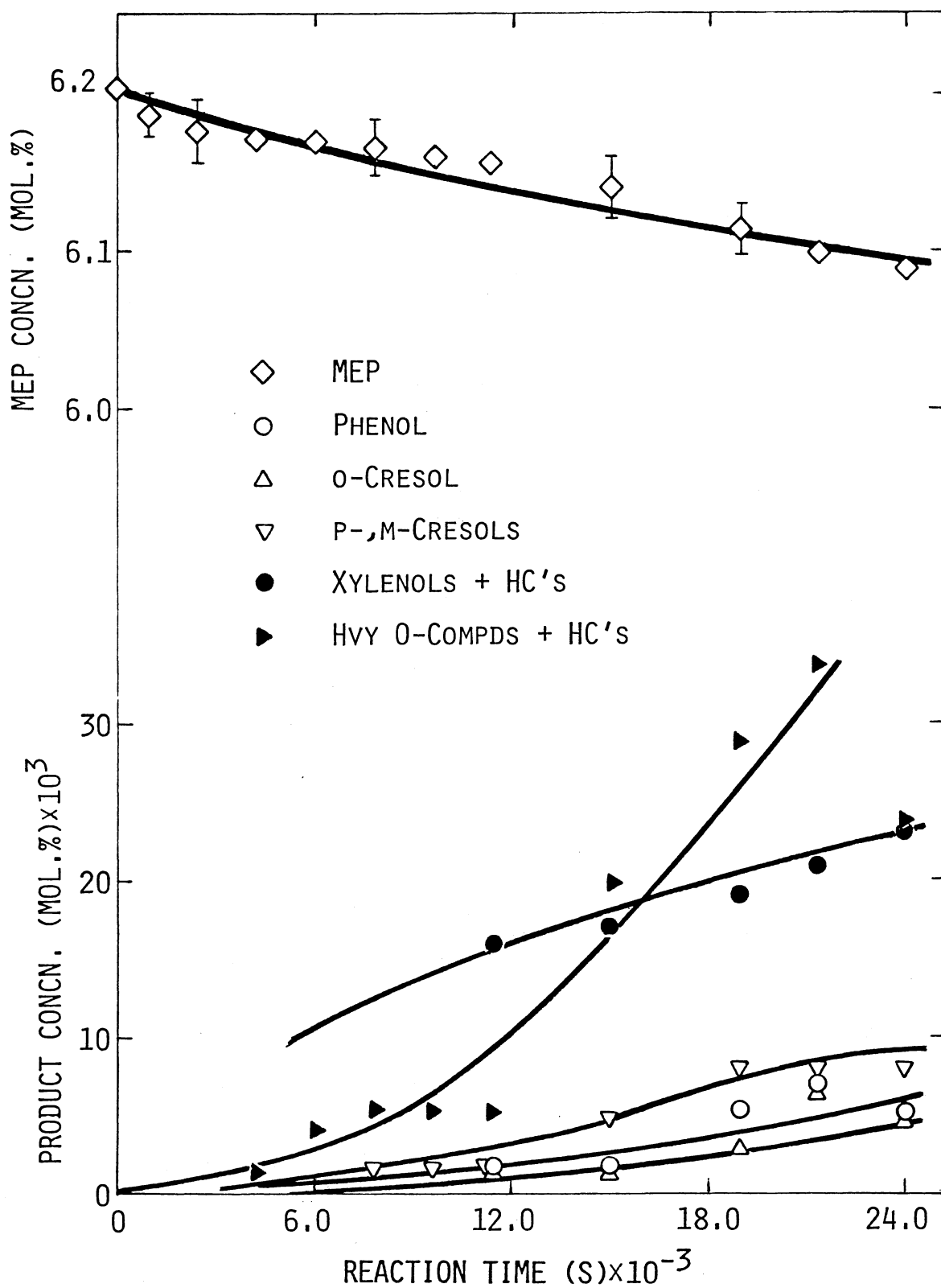

Figure 32. Product Distribution of m-Ethylphenol Thermolysis in Dodecane (Run 18, T=623 K, P=9.2 MPa, N₂)

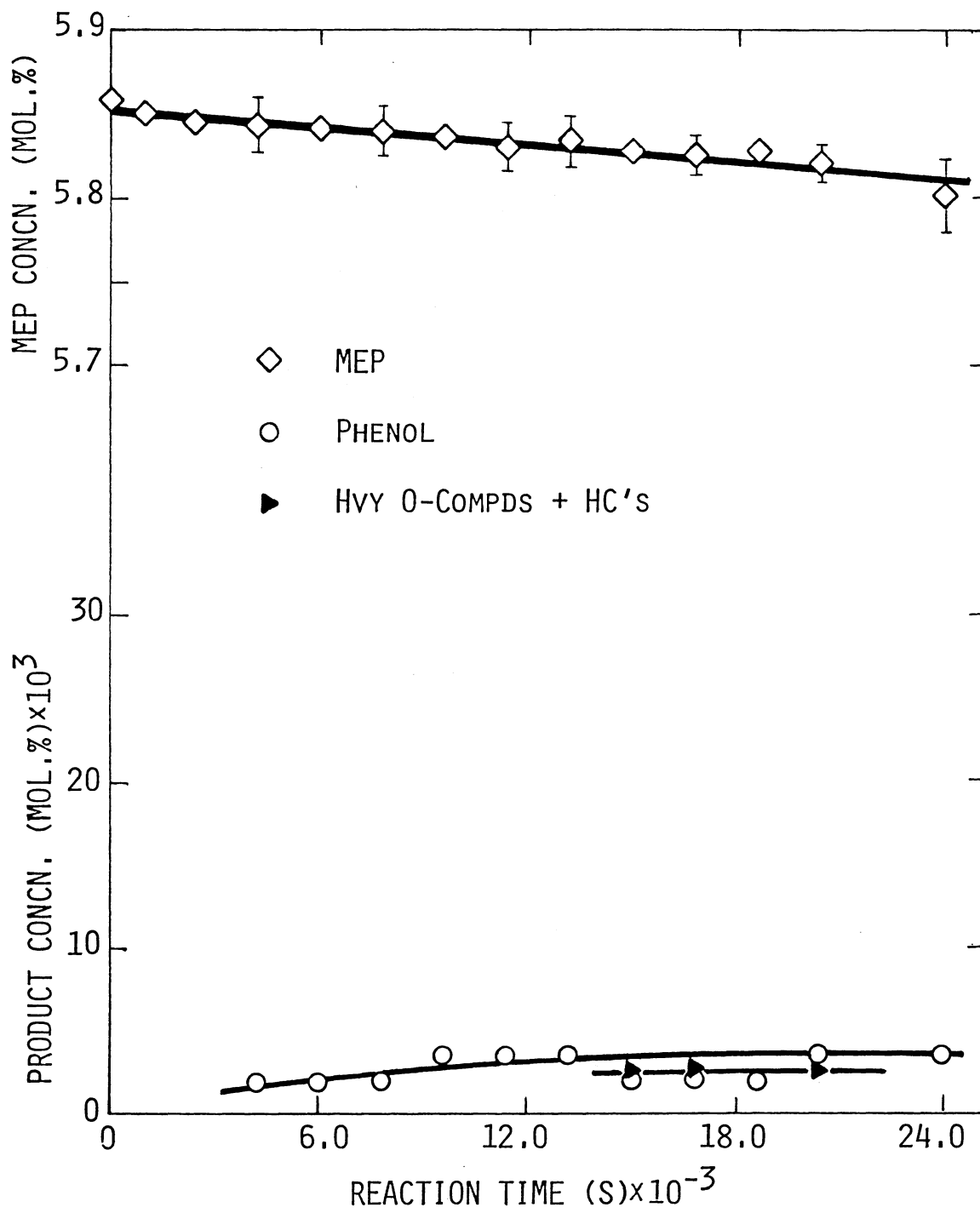

Figure 33. Product Distribution of m-Ethylphenol Thermolysis in Dodecane (Run 19, T=623 K, P=9.2 MPa, H₂)

CHAPTER V

DISCUSSION OF RESULTS

The experimental data from this research are cataloged in the preceding chapter. Here, an analysis and discussion of the significance of the data are presented.

First, the precision and accuracy of the data are assessed. Next, the thermal stability, kinetic behavior and a mechanistic study of dodecane thermolysis are given. Then the thermolysis of pure OEP is discussed, its kinetics explored, and the reaction mechanism and network suggested. The interpretation of thermolysis data for OEP in dodecane and an elucidation of the mutual interaction between the solute and the solvent in the course of cracking follow. Finally, a comparison of the thermolytic behavior of three isomers of ethylphenol concludes this chapter.

A. Precision and Accuracy of the Data

As regards the instrumentation of this study, the thermocouples were calibrated to within 0.6 K. For most of the run time of the experiments, temperature fluctuation was kept within ± 1 K. Hence the temperatures reported in this work are accurate to within 1.6 K.

The pressure gauges were checked by comparing the three readings for the same pressure source; the differences are within reading accuracy, about 0.14 MPa. Prior to each run, the reactor system was

tested against leakage. The system was kept without noticeable pressure change for at least one hour before it was heated up. One test for pressure-tightness showed a pressure drop of less than 0.7 MPa in 16 hours (from 10 MPa, while cool). After the system was heated up, raised to set pressure, and the valves had been frequently opened and closed for a couple of hours, minor leakage was possible. The average gas plus loss percentage, being 3.6, is believed due mainly to liquid splashing while purging the sampling system before collecting liquid samples, and to a much less extent to gas leakage from gas sampling lines. These would not affect significantly the sample collection and thence yield, composition, and conversion data. However, there would still be some liquid attached to the inner surfaces of the sampling line in spite of careful purging, and this may be one of the causes responsible for the irregularities that occur sometimes in the analytical data.

A glass liner was employed to avoid possible catalytic metal wall effects. In the first three runs, a certain amount of liquid was found in the gap between the liner and the reactor wall after the reactor system had been cooled down and disassembled. In the later runs, after the reaction had been quenched, the system pressure was not released during further cooling down of the reactor till ambient temperature. In those cases, only negligible amounts of liquid were found outside the liner. This gave sound proof that the liquid in the gap between the liner and the reactor wall was formed by condensation of hydrocarbon vapor generated in the course of rapid pressure release after reaction quenching and did not exist during the reaction period. This was true at least for the runs conducted at a temperature of 623 K and 9 MPa since the system temperature was below the critical temperature (658 K)

and the system pressure well above the critical pressure (1.82 MPa) of dodecane, the influence of the small amounts of cracking and condensation products being neglected. Therefore, in experimental runs conducted at 623 K and 9.2 MPa, the conditions that were employed in most of the runs for either dodecane or ethylphenol thermolysis, the critical temperature and pressure of the latter being 703-716 K and < 5 MPa, respectively, the principal part of the reaction system is reasonably considered to be in liquid phase inside the liner and only the gas phase, mostly N₂ or H₂ plus a small amount of organic vapor in equilibrium with the liquid phase, contacts the metal wall not covered by the glass liner. In this case, we believe, the metal wall effect, if present, does not contribute significantly to the reaction.

Things are different in experiments performed at temperatures higher than 673 K, which exceed the critical temperature of dodecane. Under those conditions, the reaction system is situated in a supercritical region and the whole system must be a dense fluid instead of a two-phase system. The fluid contacts the glass wall and metal wall as well.

Surface reactions may produce the following results: (i) small amounts of unsaturated hydrocarbons are destroyed (Crynes and Albright, 1969; Dunkleman and Albright, 1976), (ii) some coke is produced. During coke formation and as C-H bonds are broken, there might be an increase in hydrogen radicals (Albright, 1978). Also, certain radicals may be destroyed in some manner at the surface.

Under our circumstances, the effect of the metal surface is difficult to evaluate, but, a rough estimation is given as follows: the reactor used in this study has a volume of 0.001 m³ and a metal wall

surface area not covered by the glass liner of 0.0136 m^2 . This gives a surface-to-volume ratio of 13.6 m^{-1} , which is equivalent to a metal coil with a radius of 0.147 m . This is much greater than those of industrial coils in the $0.013\text{-}0.064 \text{ m}$ range, for which Albright and Tsai (1983) estimated a decrease in ethylene yield of 0.125% for the case reported by Dunkleman and Albright (1976). Furthermore, the ratio of surface to mass of reacting gases is inversely proportional to the total pressure of the reactants. Our reactor operated at about 9 MPa compared to the approximately 0.3 MPa usual in pyrolysis practice, so that the surface reactions would be much less important. Moreover, any kinetic differences due to surface reactions are presumably small; hence we do not expect large net increase or decrease in free radical concentrations on account of surface influences in our study.

The temperature gradient in the reactor was not measured. As already mentioned, the stirrer speed used can produce concentration and temperature uniformity in the liquid phase inside the reactor. Because of the low conversions obtained in most of the experimental runs, heat effects of both chemical and physical changes are negligible and therefore no temperature gradient is expected between the liquid and the gas phase. The size of the reactor is small compared to that of the heating block and reactor temperature was quite stable during the long period of runs, hence we believe that the whole reactor was uniform in temperature. This would also be true when the system is operated in the supercritical region.

The only possible mass-transfer problem is related to hydrogen at gas-liquid interface in the reactor. Take dodecane thermolysis experiments Runs 12 and 14 as examples. If the main effect of hydrogen

is the suppression of coupling reactions, the fact that Run 14 gives about 2 moles less C_{12} products per 100 moles cracked reactant compared to Run 12 (see Section B of this chapter) corresponds to a hydrogen consumption of 0.001 moles approximately. The solubility of hydrogen in dodecane is estimated, from the data for solubility of hydrogen in decane (Sebastian et al., 1980), to be around 20 mol% at 623 K and 9.2 MPa. That is equivalent to about 0.5 mole of hydrogen in the liquid phase, which is five hundred times the hydrogen consumption during the entire run. Evidently, mass transfer of hydrogen could never be a problem and the thermolytic reactions in this study are within kinetic region.

As a principal analytical device, gas chromatography was used throughout this work. All the sample analyses were duplicated. Data obtained during calibration are employed here to calculate the confidence intervals of the analytical results with a confidence level of 0.95; these are shown in Table XLIV (Appendix C).

As shown by the data, the confidence limits for liquid analysis is within $\pm 1\%$. The gas analysis data have much larger error, which is caused possibly by reading error of the gas sample quantities injected by the syringe. Still they are within the accuracy of the calibration standards, which is claimed to be within 10%. Therefore, we are confident to say, at a level of 0.95, that the gas analysis data are accurate to $\pm 10\%$, which are less reliable than the liquid analysis data.

The GC instrument used in this study was not an in-line instrument. During the procedure of liquid sample analyses, vaporization of some light ends inevitably occurred. This led to a

certain unreliability in light end concentrations, mainly of $< C_5$ fraction.

Conversion and yield data, and thence kinetic constants, are obtained on the basis of liquid analysis data. Factors influencing the accuracy of the data, as discussed above, are mainly responsible for some scattering of data points. Error bars are shown in the figures with a confidence level of 0.95.

All the errors would eventually be reflected in the kinetic data. An error estimation for the kinetic constants is included as Appendix C-II to this work. The rate coefficients reported for dodecane thermolysis are accurate to within $\pm (10-35)\%$, and those obtained for o-ethylphenol conversion are accurate to with $\pm 24\%$.

B. Thermolytic Reactions of Dodecane

The goal of this part of the work is to obtain sufficient understanding and characterization about dodecane to determine its stability as a solvent and its possible interaction with the substrate - ethylphenol.

Based on the materials presented in Chapter IV, Section A, knowledge can be obtained regarding not only the thermal reactivity but also the reaction mechanism of dodecane.

B.1. Thermal Reactivity

Under mild conditions, such as 623 K and for a reaction time of 5-7 h, thermal conversion of dodecane can reach about 1%. Thus dodecane as a carrier solvent for organic oxygen compounds might have some effect on the reactions of the solute.

B.2. Reaction Kinetics

By means of regression analysis, experimental data were treated using different rate laws (Eqns. V-1 and V-2) to determine reaction order n ; results are summarized in Table XLV, (Appendix D)

$$\frac{C_0^{1-n}}{1-n} \left[1 - \left(\frac{C}{C_0} \right)^{1-n} \right] = kt \quad (V-1)$$

for $n = 1$

$$\ln \frac{C}{C_0} = -kt \quad (V-2)$$

where C and C_0 are instant and initial concentrations, respectively, k the rate coefficient, and t the reaction time.

When n varies from 0.4 to 2.0, the correlation coefficient r does not change significantly and hence should not be taken as a criterion for determination of reaction order. Analysis of variance for the regression shows that the residual mean square $s_{y,x}^2$ and Student's t value do change with n . Reaction order of 1 has the highest t value and lowest $s_{y,x}^2$ value; therefore a pseudo reaction order 1 is reasonably taken for the thermal disappearance of dodecane. A typical picture is presented in Section C of this chapter.

k Values calculated for Runs 7 and 12, which are duplicates, agree satisfactorily, and the k value obtained from the mixed data of these two runs, with a correlation coefficient 0.9887, is convincing.

The following kinetic data were obtained for dodecane thermolysis in N_2 :

$$k_{623} = 4.7 \times 10^{-7} \text{ s}^{-1}$$

$$k_{673} = 2.3 \times 10^{-5} \text{ s}^{-1}$$
$$E_a = 273 \text{ kJ/mol}$$
$$A_0 = 3.7 \times 10^{16} \text{ s}^{-1}$$

where k_{623} and k_{673} are rate coefficients for dodecane disappearance at 623 and 673 K, respectively; E_a is the activation energy and A_0 the frequency factor.

The solid curves in Figure 7 (Chapter IV) are regression lines based on first order kinetics. These lines show good agreement with the experimental data.

As shown in Table XLV, the k value for Run 14, which was conducted in hydrogen, is a little less than that for runs under nitrogen environments. This is further discussed in Section B.4 of this chapter.

The thermal decompositions of hydrocarbons other than the cyclic ones invariably occur by complex mechanisms involving the participation of free radicals, the processes are usually chain reactions. In spite of this, many of them show simple overall kinetics with integral reaction orders. As pointed out by Voge and Good (1949), first order rate law holds approximately for the thermal decomposition of paraffins at given pressures. Also noted by Rebick (1983), pyrolysis of heavy paraffins are generally first order in reactant. Regression analysis of dodecane thermolysis data in this work shows that the thermal decomposition of dodecane also shows a first order overall kinetics. This fact reasonably demonstrates that dodecane pyrolysis is not an exception. Voge and Good (1949) simply adopted first order rate law while presenting their kinetic data for thermal cracking of isododecane.

The relationship between the reaction mechanism and overall kinetic behavior must be considered with reference to the nature of the initiation, propagation and termination steps.

Based on the chain reaction theory, the order of the initiation reaction depends on the complexity of the molecule that is dissociating and on the temperature and pressure. A unimolecular reaction is more likely to be in its first order region if (i) the number of degrees of freedom is large, (ii) the pressure is high, and (iii) the temperature is low. In our case, dodecane does have a large number of degrees of freedom, the system pressures employed are moderately high, and the temperatures used are lower than usual pyrolysis temperatures. There are plenty of reasons to expect the initiation reactions in dodecane thermolysis under conditions employed in this research to be first order in nature.

Butane, already, has enough degrees of freedom for its dissociation to be first order under all the conditions that have so far been studied (Laidler and Loucks, 1972). Hence, we may be confident that the initiation steps in dodecane thermolysis are first order.

In the terminology suggested by Goldfinger et al. (1948, see Laidler, 1965), since dodecane has a first-order initiation, it must have a $\beta\mu$ or $\beta\beta M$ termination in order to obtain an overall first order rate law, where μ and β are radicals involved as a reactant in a uni- or bimolecular propagation step, respectively, and M is a third body. This is further discussed in the next section.

The observed activation energies for first order reaction of heavy paraffin pyrolysis are in the range of 251 ± 21 kJ/mol (Rebick, 1983), which are in good agreement with the value obtained in this work.

The only first order rate constant for dodecane cracking found in the literature is $1.8 \times 10^{-2} \text{ s}^{-1}$, calculated for conditions of 823 K and atmospheric pressure (Voge and Good, 1949). The values for the frequency factor and activation energy obtained in this work would give a calculated k_{823} for dodecane cracking as $1.6 \times 10^{-1} \text{ s}^{-1}$. The discrepancy is probably due to the following causes: (i) more sophisticated analytical instruments were employed in the present work, (ii) the k value given by Voge and Good was estimated by means of a flow system equation and an assumption of activation energy (251 kJ/mol) was made, (iii) their conversion (>42%) was much higher than ours (1.3% to 35.2%). The first order rate coefficients for paraffin disappearance are usually reduced with increasing depths of cracking due to product inhibition (Davis and Williamson, 1979). Finally and perhaps most importantly, (iv) much lower system pressure (atmospheric) was used by Voge and Good; however, the first order rate constant for paraffin cracking actually increases as pressure is raised (Fabuss et al., 1964).

As a consequence, the first order rate coefficients for dodecane thermolysis presented here seem reasonable.

No frequency factor values for dodecane cracking are available in the literature. However, data suggest that A-factors in bond fissions (of large groups) not developing resonance in the transition state are consistently in the range of $10^{16 \pm 1} \text{ s}^{-1}$ (Richardson and O'Neal, 1972). The pre-exponential factors for ethane, propane and butane pyrolysis have been reported to be $10^{16.5}$ (Zaslonka and Smirnov, 1979), $10^{16.3}$ (Pratt and Rogers, 1979) and $10^{15.7}$ (Powers and Corcoran, 1974), respectively. The A-factor value for dodecane cracking derived in this study is therefore reliable.

B.3. Product Distribution

Data in Tables XXII through XXIV (Appendix B), which are illustrated in Figures 8 through 12 in Chapter IV, reveal the following:

1. Product yield decreases, obviously, with increasing molecular carbon number in the order: $C_6 + C_6^{\bar{=}} > C_7 + C_7^{\bar{=}} > C_8 + C_8^{\bar{=}} > C_9 + C_9^{\bar{=}} > C_{10} + C_{10}^{\bar{=}} > C_{11} + C_{11}^{\bar{=}}$, signifying that the C-C bond energy is not uniform throughout the straight chain of dodecane. The fact that by far the least yield is for $C_{11} + C_{11}^{\bar{=}}$ proves that the terminal C-C bonds are more difficult to break.

2. The formation of products with molecular carbon number greater than 12 has an induction period of about 1-2 h (depending on reaction temperature and environment), after which the yield increases sharply. The heaviest components ever detected in liquid samples were those with molecular carbon number 22. This means that, being coupling products of the free radicals, the "heavies" were dimers of reaction intermediates, and that they began to appear only after the concentration of free radicals had attained a certain level.

3. In most cases, alkene yield is higher than the yield of its alkane counterpart.

Under conditions used and conversions attained in this investigation, no carbon formation was observed in the reaction liquid throughout the experimental period. For runs performed at 623 K, all the liquid samples and the remaining residue in the reactor at the end of the runs were water white in color, and the liquid samples and residues in runs at temperatures higher than 673 K were water white to faintly yellow. The fact that docosane was the highest molecular weight product detected in all liquid samples provides a strong argument that

the condensation processes had not undergone so far that carbonaceous products would form. However, cleaning the reactor wall with white tissue after each run revealed a very slight carbonaceous deposit. The quantity of the deposit was so small that it could not be determined and hence was statistically insignificant.

The statistical probability of product distribution for dodecane is discussed together with the proposed mechanism in Section B.6. Here, only a brief discussion about the general tendency of the thermolysis products of dodecane is presented.

According to the product distribution data for hexadecane pyrolysis reported by Voge and Good (1949), Fabuss et al. (1962) and Rebick (1981), the products covered the full range upward but methane, ethylene, ethane and propylene were especially prominent at atmospheric pressure. At a pressure of 0.02 MPa and a temperature of 775 K, only olefins were found in C₄ and above (Rebick, 1981). The elevated pressures of 2.2 MPa (Voge and Good, 1949) and 7.0 MPa (Fabuss et al., 1962) caused increased saturation of the fractions and a general shift of products toward higher molecular weights. The yield decrease with increasing product molecular weight, as observed in this study, is hence in agreement with their results. This comparison is summarized in Table VIII.

At low conversions and low pressures (a few atmospheres and below), heavy paraffins selectively crack to form olefins, methane, and ethane. Small amounts of hydrogen and propane are also observed. Among the olefins, the distribution is strongly weighted toward ethylene and propylene, although all possible olefinic products of molecular weights lighter than the reactant are observed (Rebick, 1983). Our results show

much more paraffin in each fraction although olefin yields are still higher than those of their paraffin counterparts. Undoubtedly, this can be attributed to the much higher pressure used in this study. As the pressure is raised, the rates of bimolecular reactions, such as hydrogen abstraction by radicals, increase significantly faster than unimolecular processes, such as radical decomposition. As a result, the selectivity to paraffins is favored. Doue and Guiochon (1968) made a detailed study of the effect of pressure on hexadecane pyrolysis, and found that at the highest pressure studied (about 15 MPa), equal amounts of paraffins and olefins were produced. In this work, at a pressure of 9.2 MPa, appreciable amounts of paraffins were generated but still not so much as olefins. This is reasonable since the system pressure is not so high as that employed by Doue and Guiochon (1968).

At high pressures, higher paraffins begin to appear. In their hexadecane pyrolysis at 7 MPa, Fabuss et al., (1962) observed the formation of considerable quantities of products heavier than the reactant. This phenomenon was also noticed in our experiments and is accountable, since larger alkyl radicals are stabilized before they decompose and the accumulation of larger radicals makes their collision more probable.

Our experiments were conducted mostly at a temperature of 623 K, which is much lower than those employed in the literature for paraffin pyrolysis (usually above 773 K). That is why we use the term thermolysis instead of pyrolysis. The effect of temperature on product selectivity for hydrocarbon cracking is quite complex. Generally, an increase in temperature results in an increase in the selectivity to light products, especially to methane, ethylene and hydrogen (Rebick,

TABLE VIII
COMPARISON OF PRODUCT YIELDS FROM THERMAL CRACKING
OF HEXADECANE AND DODECANE

| Reactant | Hexadecane | | | Dodecane ^d | | |
|--|----------------|------------------|------------------|-----------------------|----------------------|----------------------|
| | Pressure (MPa) | 0.2 ^a | 2.2 ^b | 7.0 ^c | 9.2(N ₂) | 9.2(N ₂) |
| Temperature (K) | 775 | 773 | 866 | 623 | 673 | 623 |
| Conversion (%) | 4.9 | 47.5 | 29.6 | 1.3 | 35.2 | 1.0 |
| Products (moles/100 moles of reactant converted) | | | | | | |
| C ₅ 's | 12.0 | 22.4 | 17.5 | 21.5 ^e | 34.8 ^e | 15.9 ^e |
| C ₆ 's | 13.2 | 26.2 | 22.5 | 24.3 | 26.9 | 24.1 |
| C ₇ 's | 13.0 | 18.6 | 19.9 | 14.7 | 14.3 | 18.7 |
| C ₈ 's | 12.2 | 12.2 | 15.6 | 15.6 | 11.4 | 16.3 |
| C ₉ 's | 11.6 | 13.2 | 13.2 | 11.2 | 6.9 | 12.8 |
| C ₁₀ 's | 11.7 | 11.0 | 10.8 | 5.4 | 3.5 | 5.2 |
| C ₁₁ 's | 10.3 | 9.2 | 10.9 | 2.7 | 0.5 | 0.5 |
| C ₁₂ 's | 9.4 | 8.2 | 9.1 | | | |
| C ₁₃ 's | 8.2 | 6.2 | 6.8 | | | |
| C ₁₄ 's | 8.9 | 7.0 | | 16.2 ^f | 21.7 ^f | 14.6 ^f |
| C ₁₅ 's | 2.8 | | | | | |

^a Rebick (1981); only olefins were found in C₄ and up.

^b Voge and Good (1949).

^c Fabuss et al. (1962).

^d This work.

^e C₄'s + C₅'s; due to vaporization during analysis, these figures are lower than practical values.

^f > C₁₂.

1983). This is due partly to the competition between hydrogen abstraction by radicals and radical decomposition. Since the former has lower activation energy than β -scission (cleavage of a C-C bond β to a radical site) of C-C bonds in the radicals (Rice, 1931), it is favored by low temperatures. Hence, the lower temperature employed in our experiments would have an effect in moving the product distribution toward higher molecular products, and less light products were expected. Such was the case.

Fabuss et al. (1962), in their hexadecane pyrolysis investigation, observed a large amount (25 wt.% or more) of the total product existed as residue at low per cent conversions (approximately 20%) and this steadily dropped with increased conversion (70-90%). In our experiments, ever-increasing residue ($> C_{12}$) yields with increasing conversion was noticed, both in 623 K experiments (conversion about 1%) and in 673 K experiments (conversion up to 35%). A logical interpretation for these observations is that there is a maximum point for residue yield. Our data are situated before this maximum while the data of Fabuss et al. beyond the maximum. Temperature would affect the location of the maximum point. In the case of Fabuss and co-workers, at temperatures 866-977 K, the maximum point seems to be at conversions lower than 20%. In our case, where much lower temperatures (623-673 K) were used, this point would be located at higher conversions. Since the activation energy for cracking is usually higher than that for polymerization, alkylation and condensation, higher temperatures favor cracking reactions and would cause a shift of the maximum point for residue yield toward lower conversion.

As mentioned above, the residue ($> C_{12}$) in this research is composed of hydrocarbons all in C_{14} to C_{22} range. Fabuss et al. (1962) also identified the compounds in their residue from hexadecane cracking to be in the range of C_{18} to C_{20} . In both cases, compounds with carbon number one greater than that of the reactant is missing, which is very interesting.

The facts that the residues obtained from heavy paraffin pyrolysis contain only hydrocarbons with carbon numbers just a few more than that of the reactant and that the molecular weights of these are obviously much too low for them to be coke precursors strongly suggest that the coke deposits observed on the reactor wall in these cases must be involved with surface reactions.

Thermal cracking of n-paraffins usually produce straight-chain alkanes and alkenes, the latter being α in nature (Rebick, 1983). The olefins reported by Fabuss and collaborators (1962), as determined by infrared absorbance, all had the double bond in the α position. The GC analyses of the liquid samples in this work also showed a regular progression of double peaks, each pair representing the normal paraffin and α -olefin of the same carbon number. Aromatics, diolefins and conjugated olefins did appear in liquid products obtained by Fabuss et al. (1962) but never became an appreciable percentage of the total. Since our experiments were undertaken at much lower temperatures and no irregular spikes were observed in the GC chromatogram of product analyses, aromatics, diolefins and conjugated olefins are considered negligible, if they ever exist at all.

B.4. Effect of Hydrogen Environment

As can be seen from Figure 7, under the same temperature and system pressure, the hydrogen environment gave less conversion of the reactant. Further examination reveals that concentration of $C_6 + C_6^=$ of Run 14 (H_2) is lower than the corresponding value from Run 12 (N_2), and that of $< C_5$ much lower. Comparisons made between individual components from these two runs (Figure 11) show that there are no significant differences between $C_7 + C_7^=$, $C_8 + C_8^=$, $C_9 + C_9^=$ and $C_{10} + C_{10}^=$ yields from these two runs.

With respect to the overall conversion, a test (Table XLVI, Appendix D) of the null hypothesis that the two runs produced on the average the same conversion led to a significance probability of < 0.05 . So the data point to a superiority (higher conversion) of Run 12, which is under nitrogen environment.

The molar product yields of Runs 12 and 14 listed in Table VIII further demonstrate that under hydrogen atmosphere the light products ($< C_5$) and heavy ends ($> C_{12}$) are less than in the run in the presence of nitrogen.

The effect of molecular hydrogen in a two-phase reaction system like ours may be attributed to two factors: physical and chemical. The influence of hydrogen on vapor-liquid equilibria of hydrocarbon systems is significant. For example, in the H_2 - CH_4 -Coal liquid system, the hydrogen solubility in the coal liquid was found to be strongly dependent on the methane concentration (Ding, F., 1982). Logically, different phase equilibria of at least the light hydrocarbons under hydrogen environment is expected and is not merely a speculation. This may bring along some complications as regards to whether the dodecane conversion is truly retarded. The difference in light hydrocarbon

yields between Runs 12 and 14 is very possibly due to different phase equilibrium behavior under different environments in the reactor and also to different vaporization losses during analysis.

Chemically, hydrogen may be directly involved in reactions, such as in coal liquefaction system (Vernon, 1980; cf. Kelkar et al., 1983). Panvelker (1982) reported the effect of molecular hydrogen on reactions of dibenzyl ether, benzyl phenyl sulfide, acetophenone and benzaldehyde. Changing N_2 to H_2 at a pressure of 10.3 MPa resulted in an increase in the rate constant. In our case with dodecane, the conversion was reduced in the presence of hydrogen. Different reactants act differently; hydrocarbon pyrolysis gives light hydrocarbons which are vulnerable to hydrogen influence in phase equilibria. This surely causes uncertainties with respect to the role of hydrogen.

Anyhow, for heavy hydrocarbons such as $> C_{12}$ and heavier, the influence of hydrogen on phase equilibrium behavior is probably much less pronounced. Hence the lower yield of the heavy ends under hydrogen can only be explained chemically. By the mechanism proposed in Section B.6, which suggests that the condensation reactions in dodecane thermolysis occur between a dodecyl radical and another radical, hydrogen seems to a certain extent to inhibit or retard condensation and subsequently reduces the yield of $> C_{12}$ fraction.

B.5. Gas Analysis

The analytical results shown in Figures 14 through 16 in Chapter IV and Table XXV in Appendix B reveal the highest yields of ethane and propane as a consequence of hydrogen abstraction reaction by small

radicals. The low yield of methane again demonstrates the difficulty of the terminal C-C bond rupture.

When paraffins and olefins of same carbon number are counted together, C_3+C_3 yields are greater than C_2+C_2 yields and C_1 yields are the lowest. This could be attributed to β -scission in radical decomposition.

No considerable difference was shown between gas sample compositions from Runs 12 and 14 (Figure 14). Little discrepancies between a few data points might be attributed to different phase equilibrium behaviors of the environmental gases, N_2 and H_2 .

B.6. Reaction Mechanism

Thermal cracking of hydrocarbons proceeds via free radical reactions. The following mechanism is proposed:

I. Chain Initiation

When an organic compound decomposes, it is broken up into two (may be more) radicals depending on the number of bonds in the molecule.

The strength of the C-C bond in paraffins is 300-318 kJ/mole and that of the C-H bond about 377-398 kJ/mole. Paraffins therefore decompose exclusively through rupture of C-C bonds.

If the strengths of all C-C bonds in dodecane are considered to be the same, then the following initiation reactions have equal opportunities to occur.

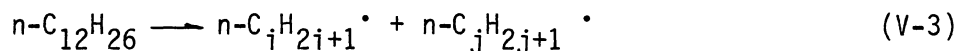

where $n\text{-C}_i\text{H}_{2i+1}^\bullet$ and $n\text{-C}_j\text{H}_{2j+1}^\bullet$ are free radicals¹, $i = 6-11$, $j = 1-6$, and $i + j = 12$.

The primary radicals generated in Reaction V-3 face three possibilities: (i) mutual collision and recombination into a molecule, which is very improbable at the early stages of initiation reactions on account of the extremely low radical concentrations, (ii) radical decomposition into one or more molecules and smaller radicals, and (iii) abstraction of a hydrogen atom from surrounding dodecane molecules and formation of saturated molecules and primary or secondary dodecyl radicals. When the experiments start with pure dodecane and moderately high pressures are used, the initial radicals most probably collide with dodecane molecules before they decompose, hence option (iii) predominates.

II. Chain Propagation

Reasonably, the first step of the reaction chain is hydrogen abstraction from dodecane by the initial radicals, giving primary or secondary dodecyl radicals.

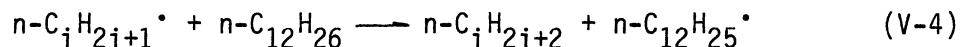

where $i = 1$ to 11 .

The dodecyl radicals decompose into smaller molecules (products) and radicals, which in turn attack dodecane molecules again leading to new dodecyl radicals. Then another chain cycle begins. Rationally,

¹ $n\text{-C}_i\text{H}_{2i+1}^\bullet$ is to be understood as a radical derived from $n\text{-C}_i\text{H}_{2i+2}$ by the removal of any one hydrogen atom. But, in Eq. (V-3), only primary radicals are formed.

dodecyl radical is the principal chain carrier. The radicals shown in Reaction V-3 are also regenerated and disappear in their respective cycles, as will be shown below. In this sense, they are also chain carriers for their own cycles. But, since dodecyl radical is formed in every cycle, we consider it to be the main carrier and use R^\bullet to designate the other radicals.

If the reaction chain is fairly long, the products are mainly determined by the chain carriers and practically independent of the initial decomposition of dodecane. As a consequence, the products of Reaction V-4 are considered to be side reaction products. Although most of them may appear in the chain cycles, a few may not. This is discussed later.

In order to simplify the problem, only a small fractional decomposition of the reactant is considered. For Run 12 and 14 (623 K, 9.2 MPa), the total conversion is less than 2%. The requirement that Rice's theory (1931, 1933) is for the initial cracking and does not take into account secondary reactions is amply fulfilled here. Run 13 has a higher conversion of 35%.

In detail, the reactions that start the chain cycle are:

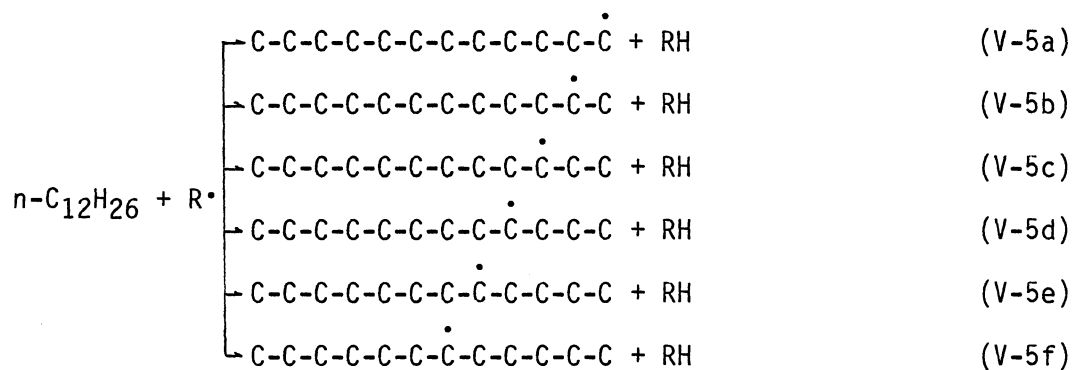

According to Kossiakoff and Rice (1943), the stabilization of a secondary radical due to resonance, now called hyperconjugation, is about twice as great as that of a primary, and that of a tertiary about three times as great. A value of 8.4 kJ/mole was given by them to be the difference in activation energy for removing a primary and secondary hydrogen. Also with a statistical factor, S , to take care of the number of hydrogen atoms of the particular kind available, the relative probabilities, P , of radical formation by loss of any particular hydrogen atom from dodecane can be calculated and are as follows.

| Reaction | Relative Act. Energy, ΔE (kJ/mol) | $e^{-\Delta E/RT}$ (623 K) | $e^{-\Delta E/RT}$ (673 K) | S | Relative Probabilities P | | | |
|----------|---|----------------------------|----------------------------|---|--------------------------|-------|-----------------|-------|
| | | | | | simple | Rice | Kossiakoff-Rice | |
| | | | | | 623 K | 673 K | 623 K | 673 K |
| V-5a | 0 | 1 | 1 | 6 | 6 | 6 | 6 | 6 |
| V-5b | -8374 | 5.0 | 4.5 | 4 | 20 | 18 | 101 | 80 |
| V-5c | -8374 | 5.0 | 4.5 | 4 | 20 | 18 | 101 | 80 |
| V-5d | -8374 | 5.0 | 4.5 | 4 | 20 | 18 | 101 | 80 |
| V-5e | -8374 | 5.0 | 4.5 | 4 | 20 | 18 | 101 | 80 |
| V-5f | -8374 | 5.0 | 4.5 | 4 | 20 | 18 | 101 | 80 |

Based on Kossiakoff-Rice theory, a dodecyl radical can coil around and react with itself to produce isomers and an equilibrium between primary and secondary dodecyl radicals is very likely established because of much smaller activation energy than that of decomposition. In computing the equilibrium among the radicals immediately prior to their cracking, the secondary radicals are estimated to be 16.7 kJ/mole more stable than the primary ones. Incorporating the appropriate statistical factors, the relative probabilities by the Rice-Kossiakoff method are obtained and listed together.

The radicals produced via reaction V-5a through V-5f may undergo three types of decomposition, for example

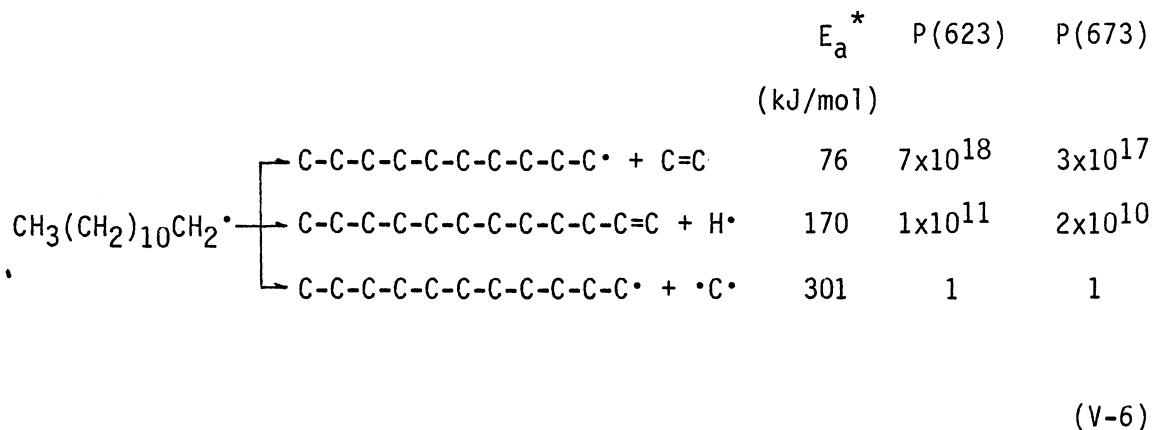

*from Rice (1931)

Obviously, β -scission of the C-C bond dominates absolutely. This is true for all dodecyl radicals obtained in Reactions V-5a through V-5f, but special attention is given to the radical formed via Reaction V-5c, which can break up in two ways

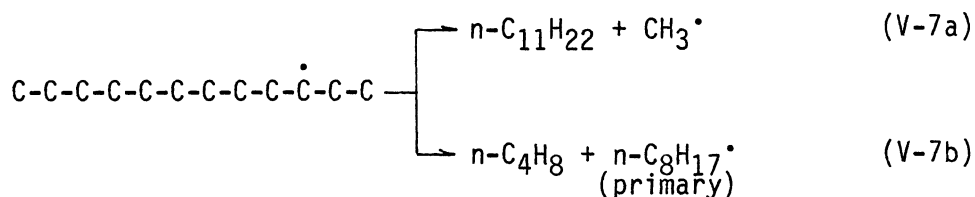

Ethyl radical and radicals larger than ethyl, such as the primary octyl radical formed in V-7b, possess resonance energy, while methyl radical does not. This would give a difference in activation energy of 8.4 kJ/mol making V-7b five times as fast as V-7a at 623 K. In the decomposition of 1-ethylbutyl radical, the calculated ratio is 3, while

the observed value is 2 (Kossiakoff and Rice, 1943). We take 3.5 for the case of 1-ethyldecyl radical decomposition.

Another important point is the fate of the radicals developed during dodecyl radical decomposition. For example, the decyl radical generated in Reaction V-6 can react in two ways:

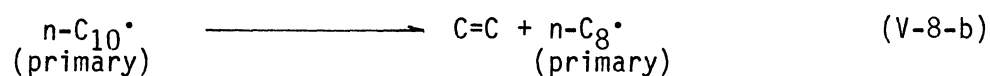
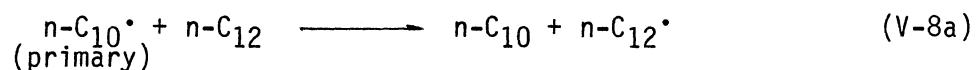

This introduces a complication into the reaction mechanism because we do not know the relative probabilities of Reactions V-8a and V-8b and hence the relative amount of $n\text{-C}_{10} : \text{C}=\text{C}$ cannot be predicted. If Reaction V-8b is favored, the radical decomposes consecutively and $\text{C}=\text{C}$ becomes a predominant product. At low pressures, radicals larger than ethyl are assumed to decompose faster than they react with hydrocarbon molecules. As a result, many paraffin pyrolyses end up with methane, ethylene and hydrogen as the only products; no paraffins larger than methane are observed (Rice, 1931, 1933; Voge and Good, 1949; Rebick, 1983). This is surely not the case with this work; the temperature is low and the pressure is relatively high, so that the competition between radical decomposition and hydrogen abstraction by the radical favors the latter, at least for smaller radicals. Low concentrations of ethylene in the gases from our experiments (Table XXV) provide strong support to this argument.

From Tilicheyev's equation (1939)

$$k = (2.3N - 15.6) 10^{-5} \quad (\text{V-9})$$

where N is the number of carbon atoms, and k is the rates constant (s^{-1}) of paraffin decomposition at 698 K, we can estimate the relative rate of cracking for $n\text{-C}_{12}:n\text{-C}_{11}:n\text{-C}_{10}:n\text{-C}_9:n\text{-C}_8:n\text{-C}_7$ as 24 : 20: 15: 10 : 6 : 1, approximately. Hence we assume, somewhat arbitrarily, that radicals smaller than heptyl undergo decomposition only negligibly compared with their reaction with dodecane molecule. That is to say, of the two reaction routes

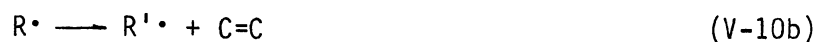
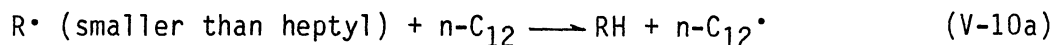

V-10a is favored by the high pressure and moderately low temperature used in this work.

For radicals larger than hexyl, we assume that V-10b is gradually favored by increasing molecular weight of the radicals with a ratio V-10b/V-10a for $n\text{-C}_7\cdot$, $n\text{-C}_8\cdot$, $n\text{-C}_9\cdot$ and $n\text{-C}_{10}\cdot$ approximates to 0.2, 0.7, 1.5 and 4, respectively.

Consequently, the following scheme is proposed for dodecane thermolysis.

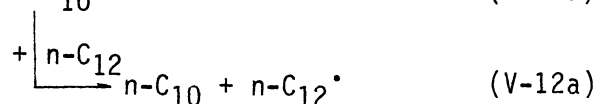
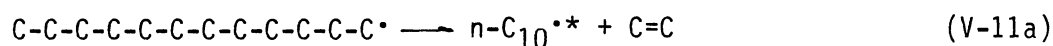

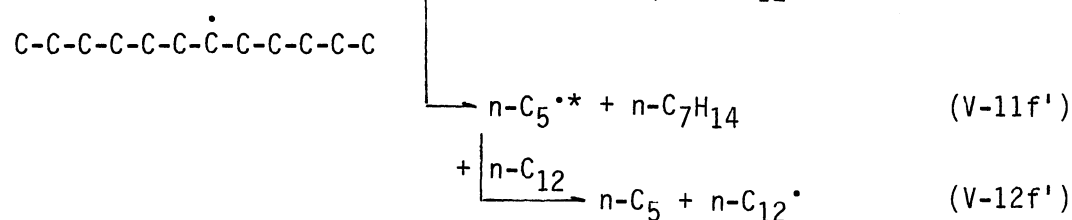
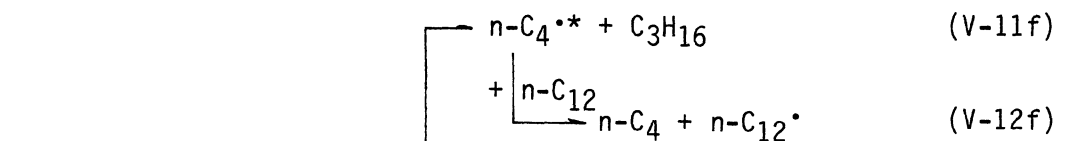
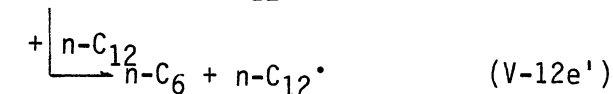
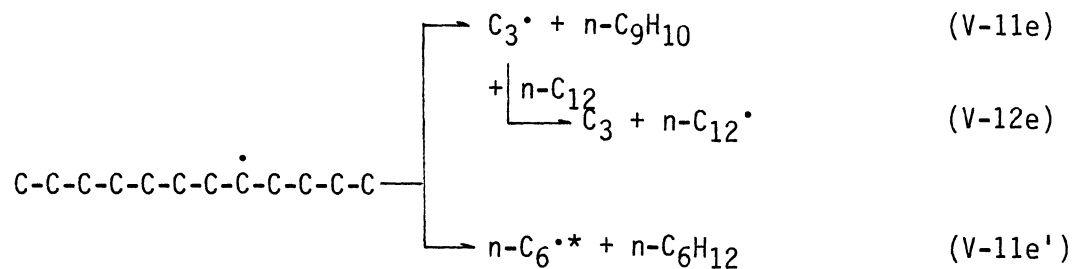
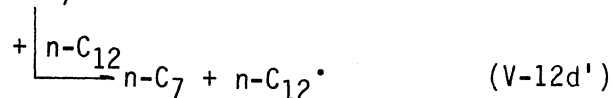
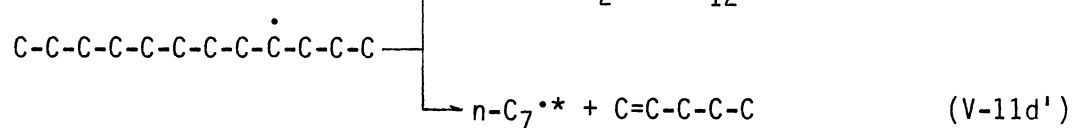
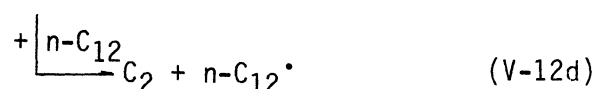
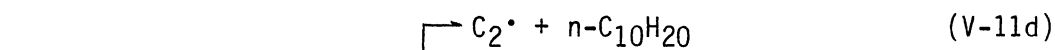
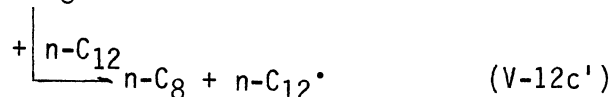
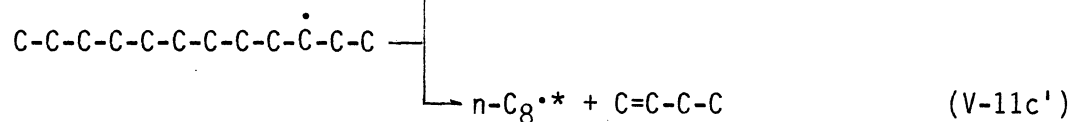
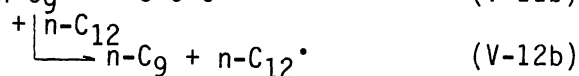
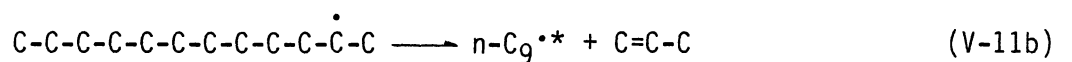

Radicals asterisked in the above scheme are primary. For simplification purpose, further decompositions of the radicals produced are not shown.

On the basis of the above discussion, the product composition is calculated and presented in Table IX, together with the observed data.

As a whole, Rice's free radical theory and the Rice-Kossiakoff modification plus our modifications give results in marked agreement with the experimental data for dodecane thermolysis. Some vaporization of the liquid samples prior to analysis accounts for the lower values of $C_4 + C_5$ fraction. Excellent consistency is obtained for C_6-C_{10} hydrocarbons except for too high values predicted for 1-nonene and 1-decene and also for 1-octene for 673 K experiment. This implies that Reactions V-11d', V-11e', and V-11f' are more favored than their counterparts V-11d, V-11e and V-11f, respectively. Long chain radicals seem to tend to crack at C-C bonds toward the center of the molecules.

The theoretical calculation gives more olefins than paraffins of the same carbon number larger than four, which is in satisfactory consistency with the observed data. Calculation results also predict decreasing yields of olefin plus paraffin with increasing molecular weight, this is partly attributed to the tendency of larger radicals, formed during decomposition of the main chain carrier - dodecyl radicals, to dissociate more prior to abstract hydrogen atoms from dodecane molecules.

This mechanism correctly predicts the low yield of methane, high yields of ethane plus ethylene, and even higher yields of propane plus propylene. It also gives a low yield of ethylene compared with that of ethane, but fails to predict low yield of propylene.

TABLE IX
 EXPERIMENTAL AND THEORETICAL PRODUCTS FROM DODECANE THERMOLYSIS
 (moles per 100 moles converted at 9.2 MPa)

| Temperature (K) | 623 | 623 | 623 | 673 | 673 |
|---------------------------------|----------------|----------------|------|----------------|------|
| Reaction time (h) | 6.7 | 6.7 | | 5.0 | |
| Environment | N ₂ | H ₂ | | N ₂ | |
| Conversion (%) | 1.3 | 1.0 | | 35.2 | |
| Products | E* | E | T* | E | T |
| CH ₄ | | 0.2 | 5.6 | 4.0 | 6.1 |
| C ₂ H ₄ | | 0.01 | 1.5 | 0.4 | 1.9 |
| C ₂ H ₆ | | 3.2 | 13.1 | 12.5 | 13.6 |
| C ₃ H ₆ | | - | 25.6 | 4.0 | 26.8 |
| C ₃ H ₈ | | 16.5 | 14.4 | 15.6 | 15.3 |
| C ₄ H ₈ | | | 19.6 | | 20.8 |
| C ₄ H ₁₀ | } 21.5** } | } 15.9** } | 13.5 | } 34.8** } | 14.4 |
| C ₅ H ₁₀ | | | 13.1 | | 13.6 |
| C ₅ H ₁₂ | | | 14.1 | | 15.3 |
| C ₆ H ₁₂ | 14.2 | 14.2 | 14.0 | 14.3 | 14.9 |
| C ₆ H ₁₄ | 10.1 | 9.9 | 12.9 | 12.6 | 13.9 |
| C ₇ H ₁₄ | 8.9 | 11.4 | 11.8 | | 12.4 |
| C ₇ H ₁₆ | 5.8 | 7.3 | 8.1 | 14.3 | 8.3 |
| C ₈ H ₁₆ | 9.7 | 9.0 | 10.6 | 7.3 | 10.8 |
| C ₈ H ₁₈ | 5.9 | 7.3 | 9.3 | 4.1 | 7.6 |
| C ₉ H ₁₈ | 6.5 | 6.8 | 9.9 | 3.7 | 9.9 |
| C ₉ H ₂₀ | 4.7 | 6.0 | 7.9 | 3.2 | 4.9 |
| C ₁₀ H ₂₀ | 3.8 | 3.7 | 9.9 | 2.6 | 9.8 |
| C ₁₀ H ₂₂ | 1.6 | 1.5 | 1.2 | 0.9 | 0.2 |
| C ₁₁ H ₂₂ | } 2.7 } | } 0.5 } | 4.4 | 0.2 | 4.4 |
| C ₁₁ H ₂₄ | | | 0 | 0.3 | 0 |
| >C ₁₂ | 16.2 | 14.6 | - | 21.7 | - |

* E = experimental, T = theoretical.

** Lower due to vaporization loss during analysis.

Generally speaking, the free radical mechanism, with certain modifications, works quite well with dodecane thermolysis, even with moderately high conversion (35%).

III. Chain Termination

The chain carriers may be destroyed in various ways. Experimentally shown, an increase of the reactor surface-to-volume ratio does not appreciably affect the rate of paraffin dissociation. Most probably, the chains are interrupted by collision of two radicals rather than by collision of the radicals with the wall (Rice, 1931). This is especially true in our case since the reactor surface-to-volume ratio is quite small.

Collision between two radicals is effective in forming hydrocarbons, presumably in two ways:

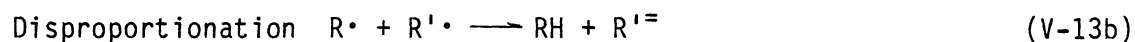

We have stated that, according to Goldfinger and coworkers (1948), in order for a chain reaction to have a first order overall kinetics, in case of unimolecular initiation, as in dodecane decomposition, the termination should be $\beta\mu$ in nature. From the above discussion, one can see that only dodecyl radical can be considered to be a μ -radical. Therefore we assume that the chain termination steps for dodecane thermolysis are most possibly induced by collision between a dodecyl radical and another smaller radical. After a detailed kinetic analysis for five decomposition reactions, Rice and Herzfeld (1934) concluded

K runs is caused mainly by the difference in conversion rather by temperature effect.

In the literature, product distribution calculations for hydrocarbon decomposition by means of free radical theory usually do not include products heavier than the reactant. For that, a detailed kinetic analysis is required. There was no intention in this work to make a full exploration of the kinetics of dodecane thermolysis, the objective was to obtain only sufficient characterization and understanding of the process to determine the stability of dodecane as a solvent and some knowledge of its interaction with the substrate - ethylphenol. More than this has been achieved here.

As a brief summary, dodecane is relatively stable as a solvent to be used in this work. In the range of conditions used here, 623 K and 9.2 MPa, under either nitrogen or hydrogen atmosphere, in a reaction period of 5 - 7 h, the conversion is around 1%. The reaction mechanism of its thermolysis can be satisfactorily interpreted by free radical theory. A reaction network is proposed and necessary kinetic constants are obtained.

C. Thermolytic Reactions of o-Ethylphenol

Data summarized in the preceding chapter provide information regarding reaction kinetics and mechanism of o-ethylphenol thermolysis, which will be developed in this section.

C.1. Reaction Order

No kinetic data for thermolytic reactions of isomeric ethylphenols can be found in the literature. An overall reaction order of 1.5 was

reported for the pyrolysis of cresols (Platonov, et al., 1981b). Kinetics of disappearance of a number of oxygen compounds, but not ethylphenols, are described in Table VI of Chapter III, with rate constants calculated according to pseudo first order rate equations.

The thermolytic experiments on pure OEP are presented in Tables XXVI and XXVII, as well as in Figures 17 and 18 (Chapter IV). Run 15 was under a nitrogen atmosphere and Run 16 in hydrogen. These data were processed by means of regression analysis and results are summarized in Table XLVII (Appendix D) and plotted in Figure 34. This figure is a representative one, since similar plots can be done for any dodecane and ethylphenol thermolysis run performed. As clearly shown by these tables and figures, just as in the case of dodecane thermolysis, by testing with reaction order from 0.4 to 2.0, a pseudo first order rate law gives best agreement with the experimental data. For any reaction order tested, the correlation coefficient remains approximately on the same level, which means it does not serve as a good criterion for determining reaction orders during regression. The estimated variance $s_{y,x}^2$ shows a distinct minimum at a reaction order of 1, and the Student's *t* value displays a sharp maximum at the same point. From the viewpoint of statistics, r^2 , the square of the correlation factor, may be described approximately as the estimated proportion of the variance of *Y* (the population property) that can be attributed to its regression on *X* (the independent variable). *r* seems not sensitive with respect to reaction order variation. However, the proportion of the variance of *Y*, s_y^2 that is not associated with its regression on *X* is estimated by $s_{y,x}^2/s_y^2$, and $s_{y,x}^2$ is directly related to $d_{y,x}$, the deviation of the observed points from the fitted regression. Hence, instead of the

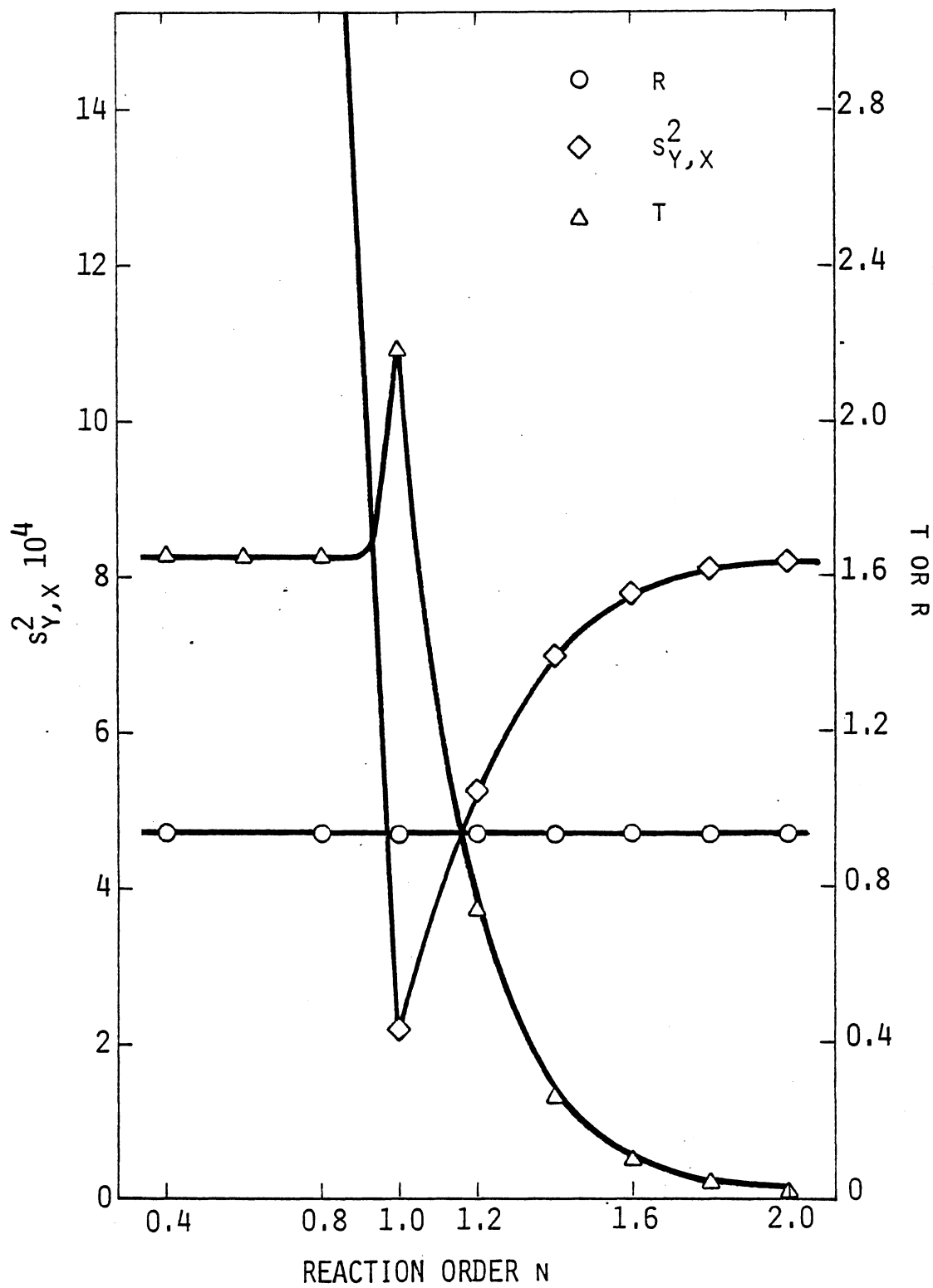

Figure 34. Regression Analysis of o-Ethylphenol Conversion Data

correlation factor r , $s_{y,x}^2$ should be used as a criterion for the determination of reaction order by means of regression technique. Furthermore, by referring the t value to the t table, one can test the null hypothesis that the means of the Y values are unrelated to X , a test of significance for the regression. The fact that the maximum t value happens to be at the same location as the minimum $s_{y,x}^2$ value, is therefore not a simple coincidence.

C.2. Reaction Kinetics

The first order rate coefficient, for reaction in either nitrogen or hydrogen, was found to be $1.6 \times 10^{-6} \text{ s}^{-1}$, by chance in the same order of magnitude as that of dodecane conversion. The kinetic data listed in Table VI, Chapter III show that pyrolyses of 1-naphthol and some other oxygen compounds have rate constants in the range of 10^{-4} to 10^{-6} at a temperature of 673 K, which is 50 degrees higher than the temperature used here. The rate coefficient presented here for OEP conversion looks reasonable. Since pure OEP thermolysis was performed at only one temperature (623 K), no activation energy can be determined.

The change in environment seems to make no significant difference in OEP conversion, although minor differences in product distribution were noticed. The test of difference between Runs 15 and 16 (Table XLVIII Appendix D) shows not enough evidence to reject the null hypothesis that the same conversion was achieved in N_2 or H_2 atmosphere with otherwise identical conditions. This is different from the case of pure dodecane thermolysis and is discussed later.

C.3. Product Distribution

Benzene, toluene and ethylbenzene were found in small quantities. These must be the deoxygenation products of the corresponding phenols. As shown in Table XXIX, the analytical data of the condensates obtained from gas samples show that a considerable part of the aromatics is in the gas phase owing to their higher relative volatilities. The irregularity in aromatics concentrations in the gas condensates might be attributed to the very small quantities of the condensate samples obtained, and hence, varying vaporization loss from sample to sample. Since these light aromatics are much more volatile than the oxygen compounds in question, they tend to escape more easily.

Obviously, phenol is the main product of thermolytic conversion of OEP, most probably as a result of deethylation. This is consistent with the fact that ethane plus ethylene are the predominant gas components.

Product yield data are listed in Table XI. Phenol accounts for about one half of the products. The next important class of products are the isomers of OEP, which amount to around 20%. This proves the occurrence of isomerization reaction of the ethylphenols.

Small amounts of cresols were found in the reaction products. They should be the demethylation products of the ethylphenols; isomerization of cresols is also probable.

An appreciable amount of methane was detected in the gas phase. The molar ratio of $(C_2 + C_2^=)/C_1$ has an average value of 2.7 - 2.8 (Table XXVIII), which is considerably lower than the molar ratio phenol/cresols, on an average of 8.8 (Tables XXVI and XXVII). From material balance, out of 100 moles of reactant converted, the number of moles of methane produced is approximately equal to the number of moles

TABLE X
 PRODUCTS FROM o-ETHYLPHENOL THERMOLYSIS
 (moles per 100 moles converted)

| Run No. | 15 | | | 16 | | |
|------------------------|----------------|------|------|----------------|------|------|
| Environment | N ₂ | | | H ₂ | | |
| Temperature (K) | 623 | | | 623 | | |
| Pressure (MPa) | 9.2 | | | 9.2 | | |
| Reaction time (h) | 1.67 | 3.33 | 5.00 | 1.67 | 3.70 | 5.00 |
| Conversion (mol%) | 0.66 | 1.02 | 2.04 | 0.63 | 1.46 | 2.42 |
| Products | | | | | | |
| Benzene | 0.2 | 0.1 | 0.1 | - | - | - |
| Toluene | 1.4 | 1.3 | 0.4 | 2.3 | 0.8 | 0.7 |
| Ethylbenzene | 0.3 | 0.2 | 0.1 | 0.2 | 0.1 | 0.2 |
| Phenol | 47.6 | 51.4 | 53.8 | 55.0 | 46.3 | 56.5 |
| o-Cresol | 0.8 | 1.1 | 1.5 | - | 2.8 | 1.1 |
| p-Cresol | 6.1 | 4.9 | 3.9 | - | 5.3 | 3.4 |
| m-Cresol | | | | | | |
| p-Ethylphenol | 14.7 | 15.1 | 14.4 | 18.0 | 19.9 | 14.2 |
| m-Ethylphenol | 4.4 | 5.4 | 8.0 | 4.8 | 8.5 | 9.7 |
| Xylenols | 1.2 | - | - | | | |
| Heavy oxygen compounds | 23.3 | 2.50 | 17.8 | 20.0 | 16.3 | 14.2 |

of cresols formed. This suggests that cresols are demethylation products of the ethylphenols with equal molar amounts of methane generated. However, the ethane and ethylene found in the gas are much less than the stoichiometric quantity if phenol is formed by splitting off the ethyl group from ethylphenol molecules. One possible explanation is that an appreciable amount of ethyl radicals is consumed in reactions other than hydrogen transfer.

Quite a large amount of heavy oxygen compounds is formed in OEP thermolysis. Most of the impurities in OEP used as feed are thermolytic reaction products of OEP. They are considered to have no effect on OEP thermolysis, and of course, are excluded in counting the product yields. After thermolytic reaction, besides the pre-existing compounds, o-isopropylphenol and 2-methyl-5-isopropylphenol were detected in the heavy oxygen compounds. Very probably, ethyl radicals split off from ethylphenol molecules react with other large radicals and form some of these heavy oxygen compounds. This will be discussed further in the following section.

C.4. Reaction Mechanism

Free radical mechanisms have been frequently used to explain oxygen compound pyrolyses (e.g., Huibers and Gendler, 1981; Bredenberg and Ceylan, 1983; Bredenberg et al., 1982). Based on the experimental observations discussed before, a free radical mechanism is explored here for the thermolysis of OEP.

I. Chain Initiation

The reaction chain can be initiated via homolytic scission of appropriate bonds in the OEP molecule in the following possible ways:

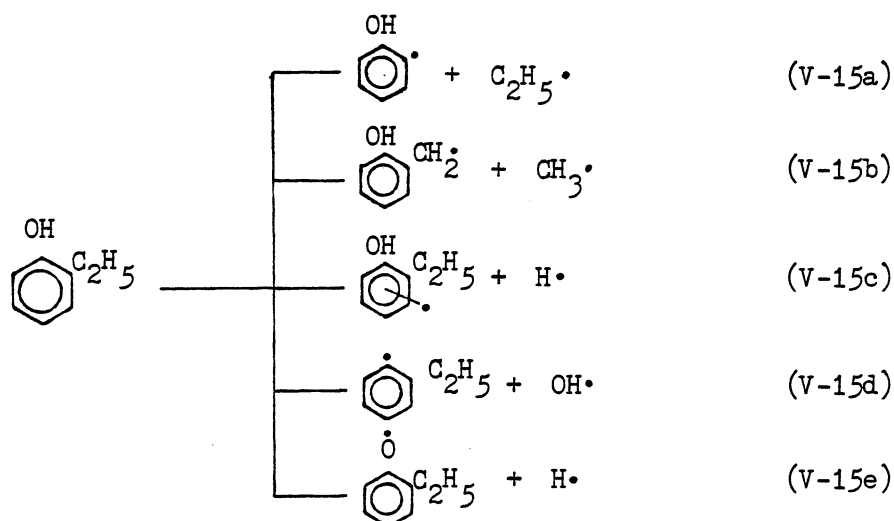

The energy requirements for breaking O-H, C-H, C-O and C-C bonds are approximately 460, 389-415, 352 and 301-318 kJ/mol, respectively. Hence, any breaking of O-H and C-H bonds (Equations V-15c and V-15e) is wholly negligible compared to that of C-C bond. The possibility of C-O bond scission (Equation V-15d), compared to that of the C-C bond, is also low. Of the two reactions V-15a and V-15b, V-15a is more likely to occur because the resonance energy of phenol, which is even higher than that of the benzene nucleus, may affect the adjacent C-C bond more than the remote one. Therefore, we assume that Equation V-15a is the most important initiation reaction, Equation V-15b the next, and Equation V-

15d to a much lesser degree. The relative probabilities of the chain initiation reactions are not important if the chain is fairly long.

II. Chain Propagation

Generally speaking, the first step in chain propagation is hydrogen abstraction by the radicals produced in the initiation stage from the surrounding OEP molecules. This could be realized through several possible routes:

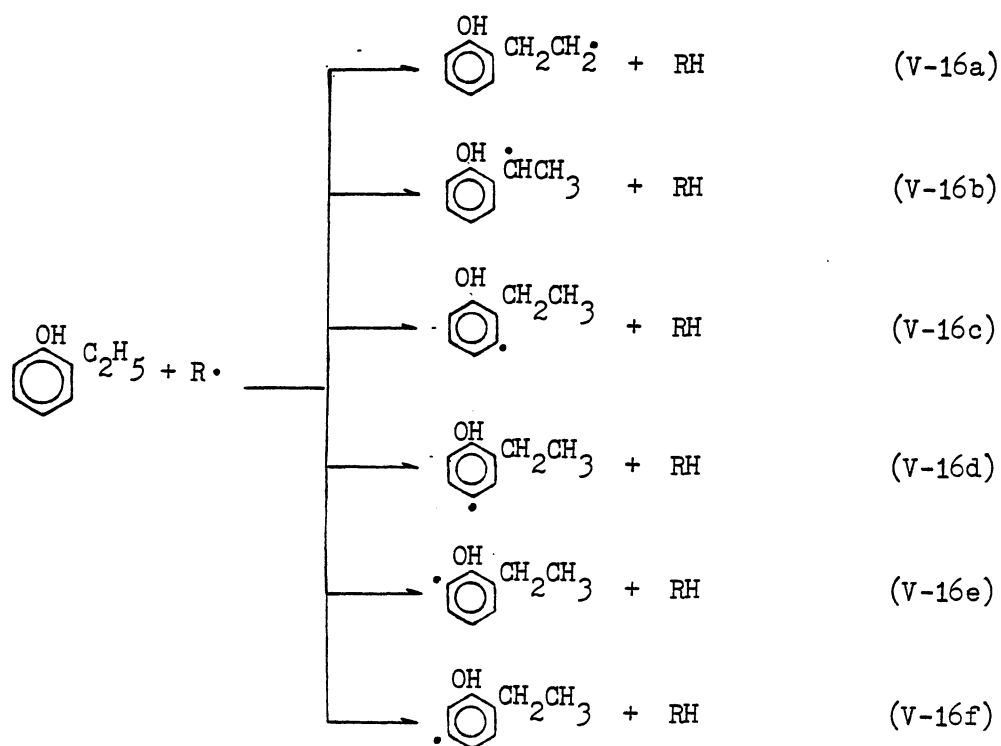

The C-H bond dissociation energy for toluene was found to be 100 kJ/mol lower than that for alkanes, as determined by Szwarc (1948) from its rate of pyrolysis and by Schissler and Stevenson (1954) by electron impact. According to Pauling (1960), this difference can be attributed to the resonance stabilization of the benzyl radical that is produced by removing one hydrogen atom from the methyl group of toluene and resonates among the several structures

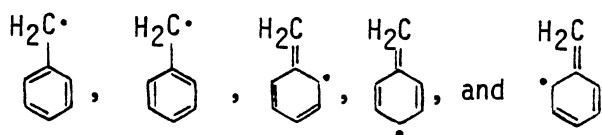

In the case of ethylphenol, the co-existence of the -OH group attached to the ring makes the circumstances much more complicated and a quantitative evaluation very difficult, however, the same argument holds. The radical obtained by loss of a hydrogen atom from the secondary carbon atom of the side chain is very probably formed. These radicals may undergo various reactions:

(a) Radical decomposition

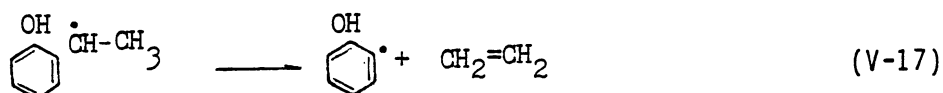

(b) Internal rearrangement

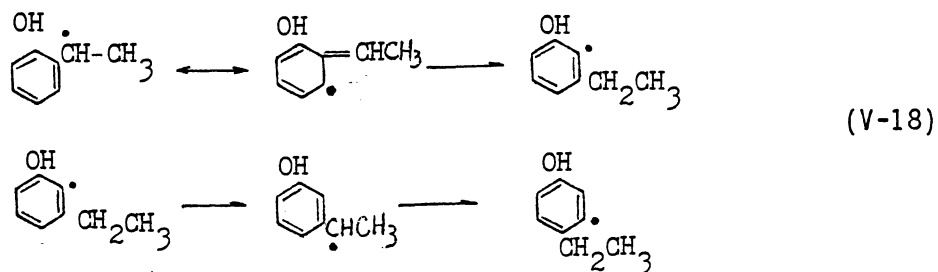

The new radicals formed in Reaction V-18 can either undergo dissociation giving hydroxyphenyl radicals and ethylene, or abstract hydrogen atoms from the reactant molecules. Most of the time, hydroxyphenyl radicals are formed and they surely will abstract hydrogen atoms from ethylphenol and thus continue the chain reaction, being themselves regenerated in the new cycle. They are therefore chain carriers.

III. Chain Termination

Termination of the reaction chain most probably occurs via combination of an alkyl and an aryl radical since no product was found with more than one ring. Disproportionation is also unlikely since products with unsaturated side chains have not been identified. No suitable termination can be formulated on the basis of the above reaction scheme.

The mechanism discussed above can explain only: (i) phenol being the main product, and (ii) the occurrence of ethylphenol isomerization. It can not explain: (i) the formation of a certain amount of cresols, (ii) the existence of relatively large quantity of ethane, (iii) deficiency of ethane plus ethylene compared to the stoichiometric value, and (iv) termination of the chain.

On the basis of the above reasoning, we believe that although free radicals do play an important role in thermolytic reactions of OEP, the chain is relatively short and unimportant. As a consequence, homolytic unimolecular decomposition is most significant. The result is that Reactions V-15a, V-15b, and even V-15d now account for the final product distribution. In the meantime, radicals formed in these reactions enter

the reaction scheme giving a more complicated picture. In addition to the reactions cited above, the following reactions take place

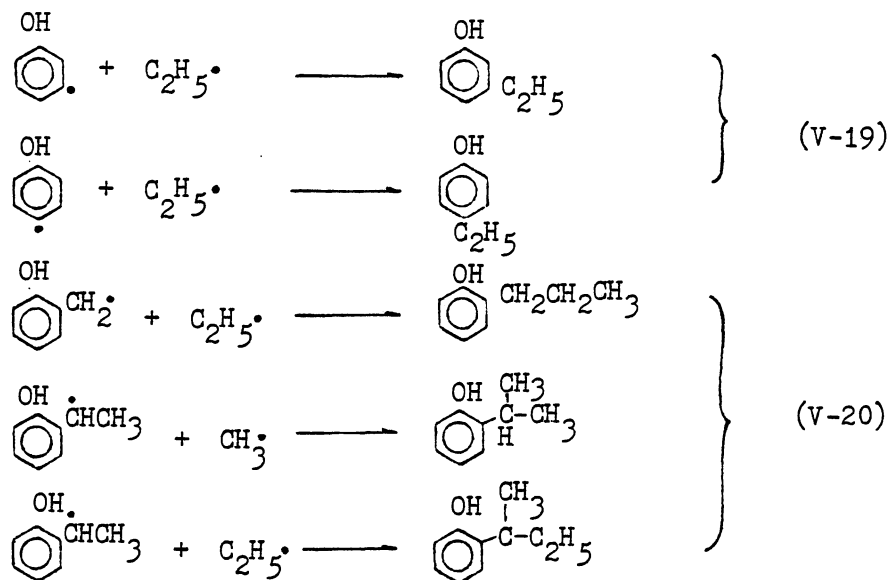

These reactions all tend to terminate the short-lived chain. Reaction V-19 provides another route for ethylphenol isomerization, and Reaction V-20 shows how heavier oxygen compounds are formed. The shortage of ethane is also clear from these reactions, and the short chain length itself limits the amount of ethylene, moreover the production of the cresols and methane is elucidated.

Although the hydrogen atmosphere does not show an effect on overall conversion of OEP, at least apparently, it lowers the yield of the heavier oxygen compounds to a significant extent. This may be attributed to radical capping by molecular hydrogen in competition with the coupling reactions

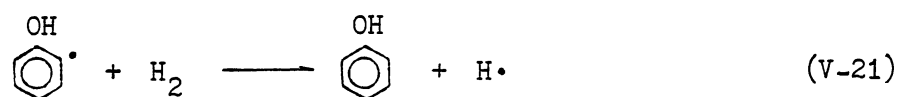

and the like. This is further evidenced by comparing the molar ratio C_2^{\equiv}/C_2 in Table XXVIII, which shows a definite decrease of this value under hydrogen environment. Nevertheless, the radical capping by hydrogen has a heat of activation of 59 kJ/mol for ethyl radical while that for radical coupling is essentially zero (Denti and Ranzi, 1983); thus the influence of hydrogen can be only minor in nature.

A simplified material balance was made to roughly estimate the chain length of pure OEP thermolysis under the present conditions with the assumptions: (i) isomeric ethylphenols are produced solely via Reaction V-19, and (ii) only ethyl radicals enter Reaction V-20. From the product yield data listed on Table XI and the molar ratio $C_2^{\equiv}/C_2 = 0.50$, we obtain that out of 100 moles of reactant thermolyzed, 12 moles of phenol are produced by Reaction V-17 and 64 moles of phenol are formed through unimolecular decomposition Reaction V-15a, of which 22 moles are converted into p- and m-ethylphenol and moles finally turn into heavier phenols.

This could hardly be called a reaction chain; although free radicals do take part in the overall reaction, the homolytic unimolecular reactions determine the product distribution pattern. Hence, the chain mechanism is not meaningful; a reaction scheme (Figure 35) is suggested instead and a proposed network (Figure 36) follows.

D. Thermolytic Reactions of o-Ethylphenol in Solvent

Thermolysis experiments of OEP in the carrier solvent were performed with an initial OEP concentration around 5 mol%. The effect of temperature, pressure, and environment, as well as the mutual influence of OEP and n-C₁₂ upon each other, are discussed here.

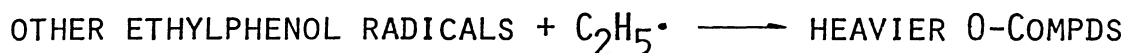
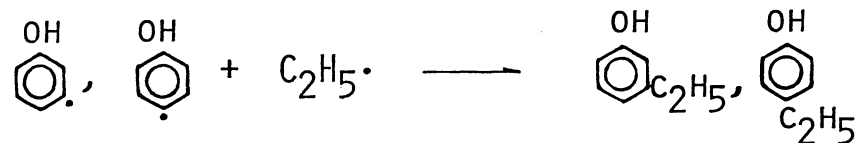
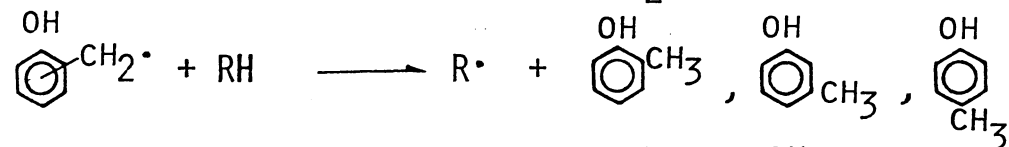
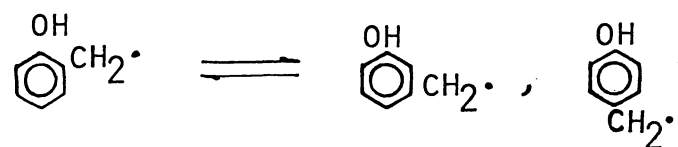
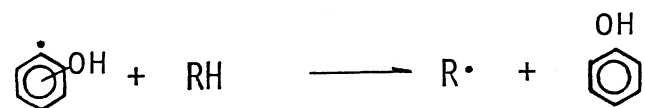
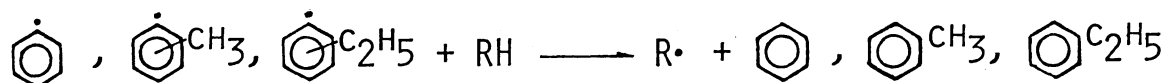
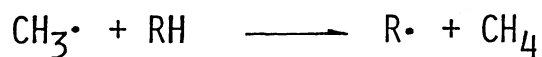
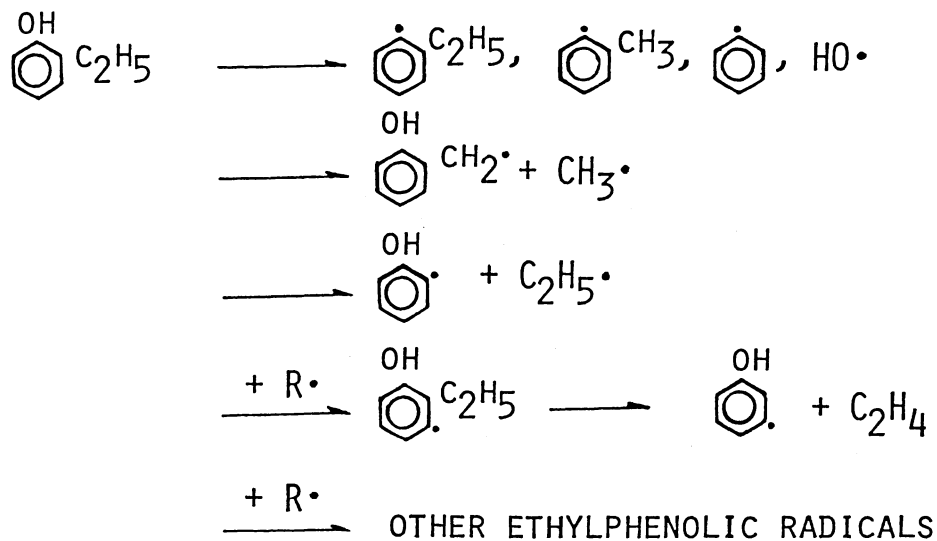

Figure 35. Reaction Scheme of o-Ethylphenol Thermolysis

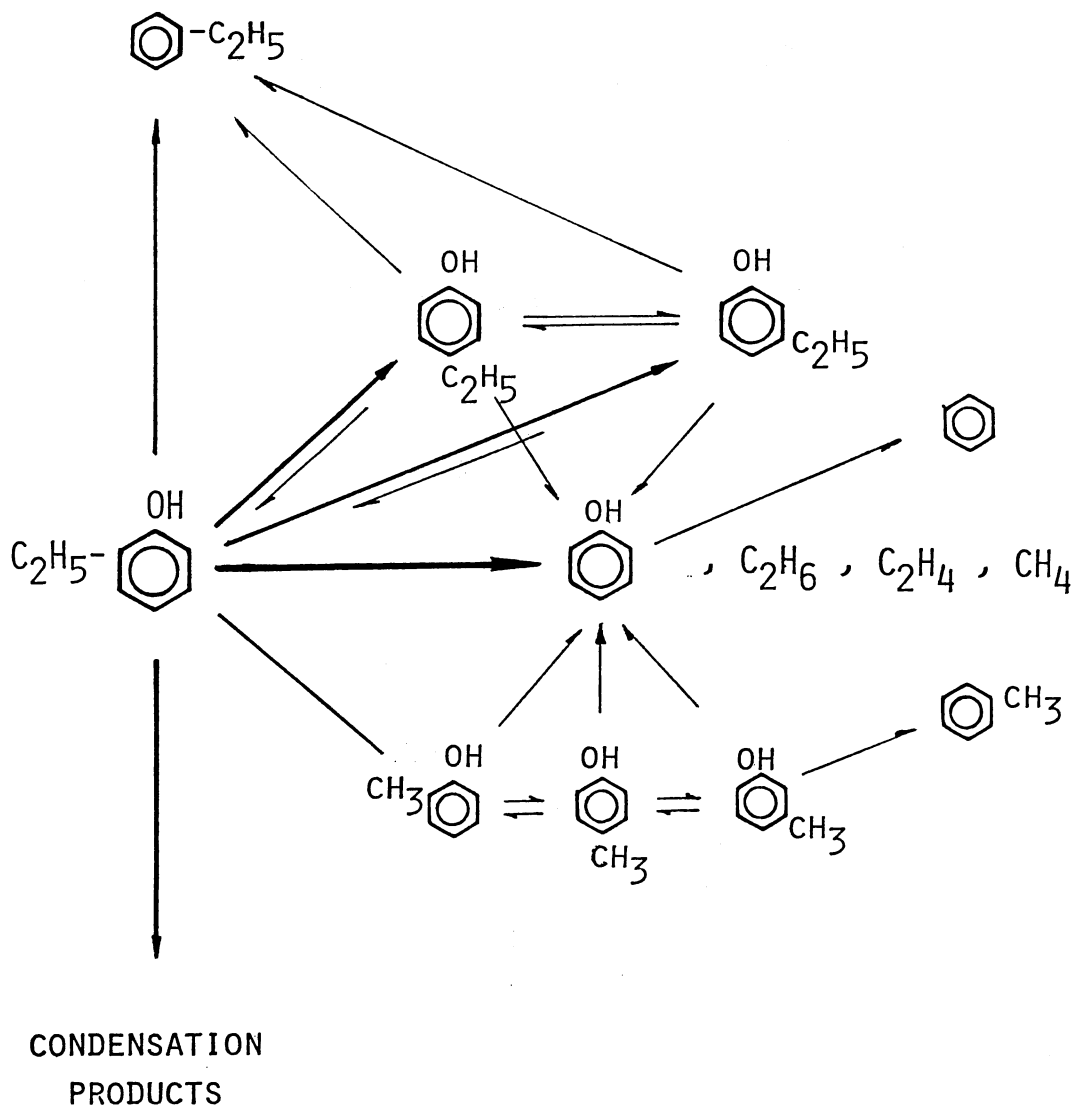

Figure 36. Proposed Reaction Network for o-Ethylphenol Thermolysis

D.1. Reaction Kinetics

Table XLVIII, Appendix D, lists the regression analysis results of the experimental data of replicate Runs 3 and 6, thermolysis of OEP in dodecane at 623 K and 9.2 MPa under nitrogen environment. As for pure dodecane and pure OEP thermolysis, pseudo first order rate laws seem to apply best.

The noteworthy point is that the rate coefficient for OEP overall reaction, $4.1 \times 10^{-6} \text{ s}^{-1}$, is two and one-half times that obtained in Run 15, the pure-OEP thermal reaction. This suggests that in a solvent such as dodecane, the reaction of OEP was accelerated. This will be further discussed later.

D.2. Thermolysis of o-Ethylphenol in Dodecane under Different Conditions and Nitrogen Atmosphere

The OEP conversion (in dodecane) data at different temperatures under nitrogen environment are placed together in Figure 37 and first order rate coefficients for OEP disappearance of these runs in Table XI. Figure 38 is the Arrhenius plot of corresponding rate constants.

The kinetic constants for thermolysis of OEP in dodecane then are as follows:

$$E_a = 165 \text{ kJ/mol}$$

$$A_0 = 2.3 \times 10^8 \text{ s}^{-1}$$

This activation energy is typical of thermal reactions of oxygen compounds and comparable with literature data (110-214 kJ/mol), as stated in Table VI of Chapter III.

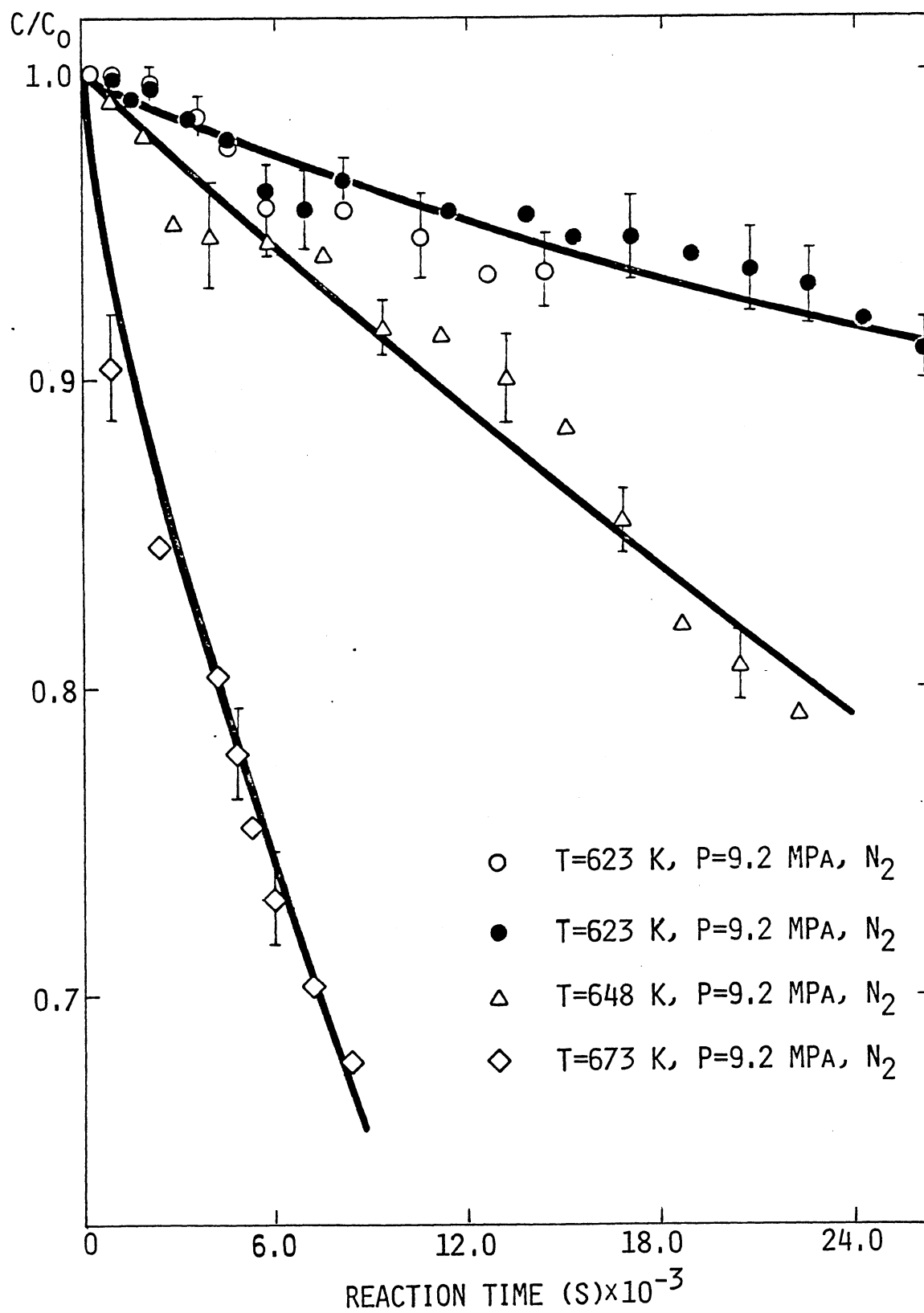

Figure 37. Temperature Effect on o-Ethylphenol Thermolysis in Dodecane

TABLE XI
FIRST ORDER RATE COEFFICIENTS OF o-ETHYLPHENOL THERMOLYSIS

| Run No. | Reactant | Temperature (K) | Pressure (MPa) | Environment | Rate Coefficient (s ⁻¹) | Correlation Coefficient r |
|---------|---------------------------|--------------------|-------------------|----------------|---|---------------------------------|
| 15 | o-Ethylphenol | 623 | 9.2 | N ₂ | 1.6x10 ⁻⁶ | 0.9360 |
| 16 | o-Ethylphenol | 623 | 9.2 | H ₂ | 1.6x10 ⁻⁶ | 0.9763 |
| 3 & 6 | o-Ethylphenol in dodecane | 623 | 9.2 | N ₂ | 4.1x10 ⁻⁶ | 0.9466 |
| 8 | o-Ethylphenol in dodecane | 648 | 9.2 | N ₂ | 9.8x10 ⁻⁶ | 0.9799 |
| 4 | o-Ethylphenol in dodecane | 673 | 9.2 | N ₂ | 4.4x10 ⁻⁵ | 0.9869 |
| 5 | o-Ethylphenol in dodecane | 673 | 7.0 | N ₂ | 4.5x10 ⁻⁵ | 0.9881 |
| 9 | o-Ethylphenol in dodecane | 623 | 4.7 | N ₂ | 2.9x10 ⁻⁶ | 0.9815 |
| 21 | o-Ethylphenol in dodecane | 623 | 9.2 | H ₂ | 1.4x10 ⁻⁶ | 0.9915 |
| 10 | o-Ethylphenol in dodecane | 623 | 9.2 | H ₂ | 2.0x10 ⁻⁶ | 0.9317 |
| 20 | o-Ethylphenol in dodecane | 623 | 15.6 | H ₂ | 7.2x10 ⁻⁷ | 0.9735 |

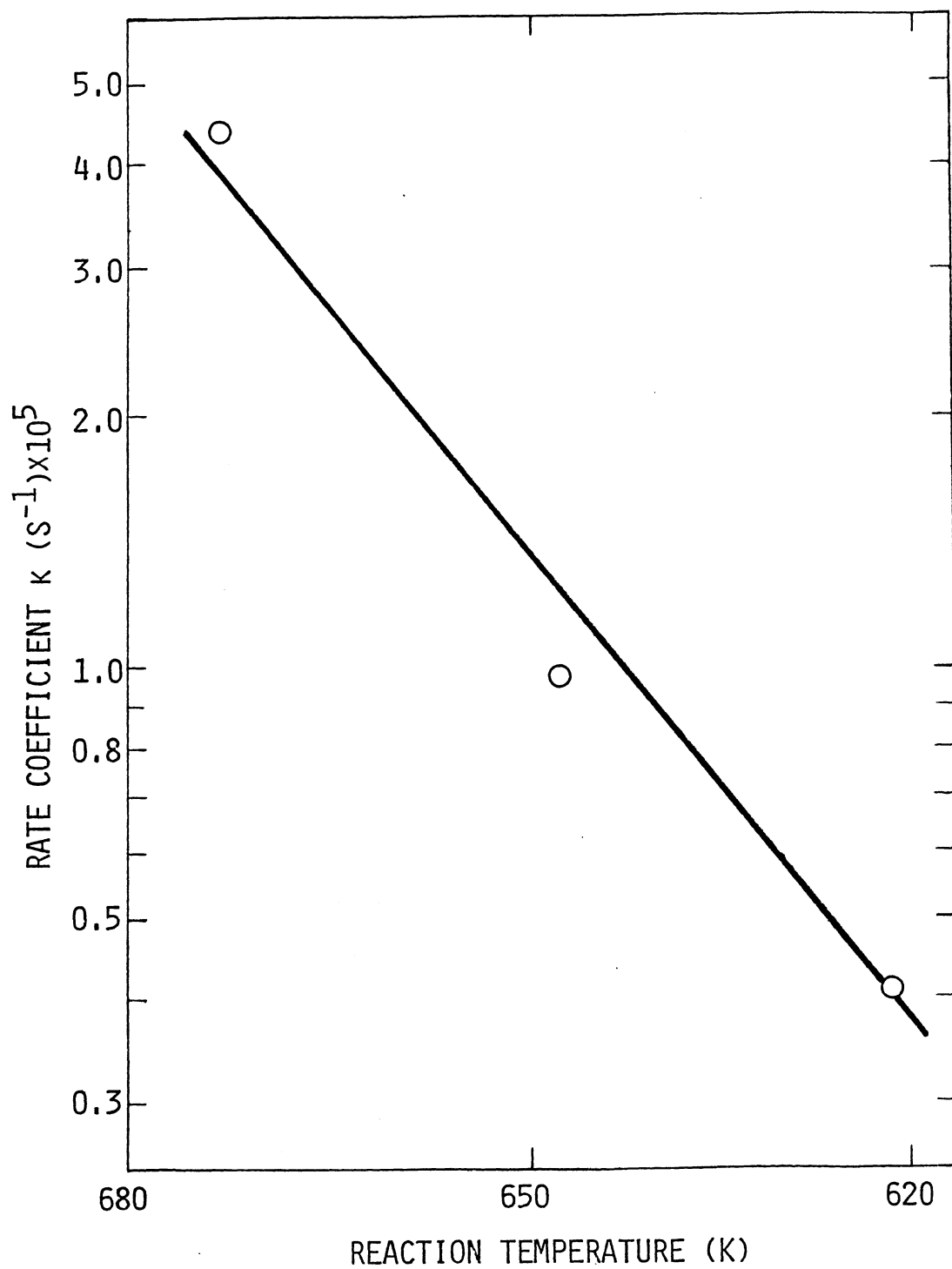

Figure 38. Arrhenius Plot of *o*-Ethylphenol Thermolysis in Dodecane

Comparing Run 4 with Run 5, both conducted at a temperature of 673 K but the former under system pressure 9.2 and the latter 7.0 MPa, data in Table XI show about the same rate constants for these two runs. No pressure influence was observed. However, at reaction temperature 623 K, Run 9, with system pressure 4.7 MPa, has a rate coefficient for OEP overall reaction of 2.9×10^{-6} , which is 29% lower than that of Runs 3 and 6. This may or may not mean a lower reaction velocity for lower reaction pressures, since the pressure difference is large enough to cause different phase equilibrium conditions in the reaction process.

D.3. Thermolysis of o-Ethylphenol in Dodecane under Hydrogen Environment

The effect of a hydrogen environment on OEP thermolysis was also investigated, and results are shown in Figure 39. As mentioned before, Runs 3 and 6 are duplicates and Runs 10 and 21 also. Although data points of these duplicated runs are somewhat scattered, the solid regression lines still show certain trend. For pure OEP thermolysis, hydrogen seems to have no significant influence on its conversion, but some inhibition effect on condensation reactions, as stated previously. For OEP in dodecane runs, Figure 39 exhibits a certain influence of the hydrogen atmosphere on the overall reaction of OEP in solvent. Comparison of the rate coefficients of OEP conversion in hydrogen with those obtained in nitrogen, as listed in Table XII, also leads to the same conclusion ($1.7 \times 10^{-6} \text{ s}^{-1}$ for H_2 versus $4.1 \times 10^{-6} \text{ s}^{-1}$ for N_2). Obviously, OEP conversion was enhanced in the presence of hydrocarbon solvent, but this enhancement was suppressed to a certain extent in the presence of hydrogen. Since this suppression effect of

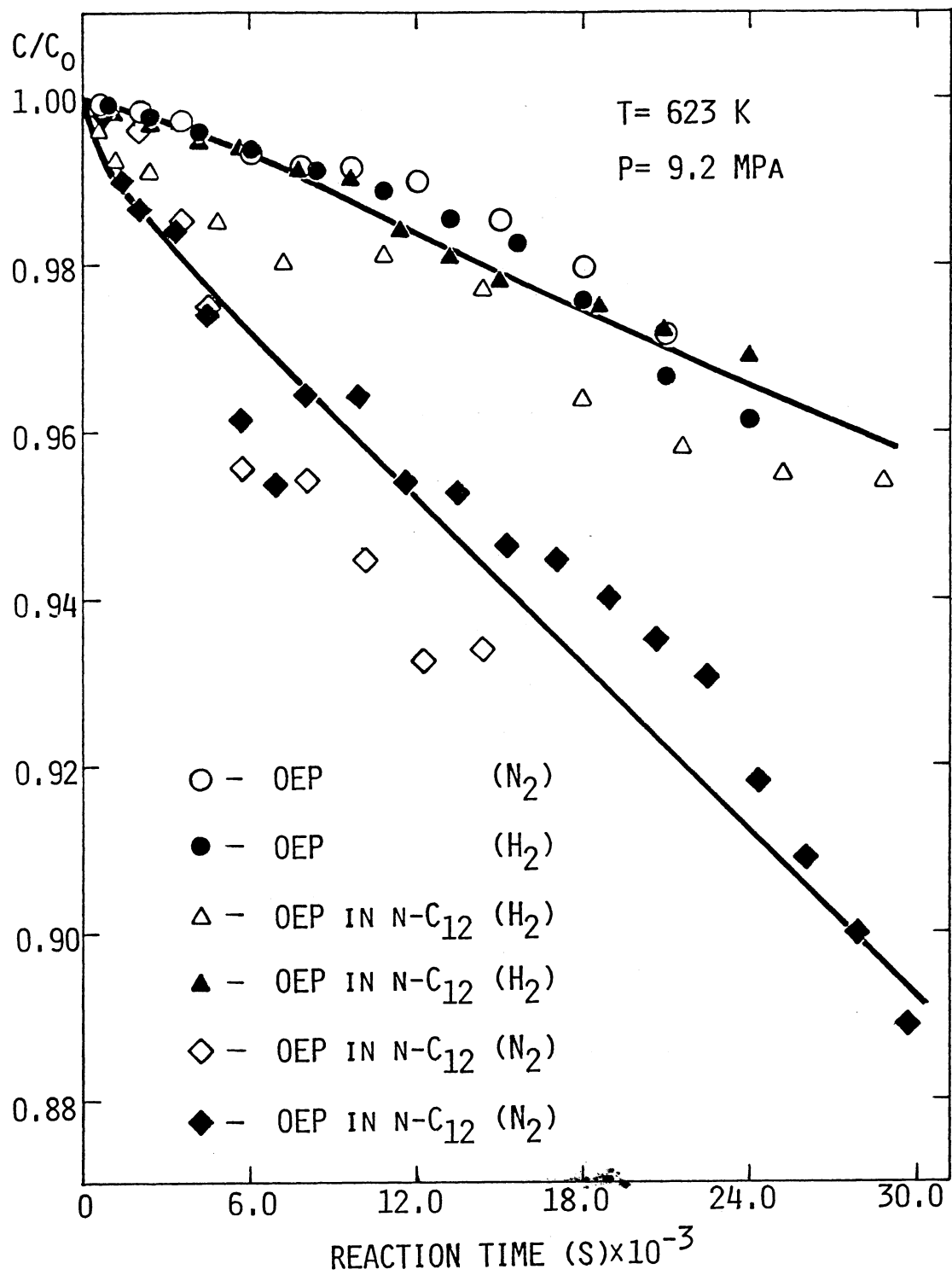

Figure 39. Hydrogen Effect on o-Ethylphenol Thermolysis

hydrogen on OEP reaction was not significant in the case of pure OEP runs, a logical deduction is that it has something to do with the solvent, as discussed later.

D.4. Effect of Hydrogen on Dodecane Conversion with or without o-Ethylphenol

Table XII lists first order rate coefficients of dodecane disappearance under various conditions and different environments. As shown clearly by the data in this table, either with or without the presence of OEP, molecular hydrogen reduced the rate of dodecane conversion. In the case of pure dodecane, the rate constant was decreased to an extent of about 36%, while for dodecane thermolysis in the presence of OEP, the already reduced rate coefficients were further decreased considerably. The rate coefficients of dodecane thermolysis with or without OEP, under various conditions, are plotted in Figure 40. The activation energy of dodecane cracking with OEP is 297 kJ/mol, about the same of that of pure dodecane (274 kJ/mol), which means no significant mechanistic difference between the thermolyses of dodecane in the absence or presence of OEP.

D.5. Yield Pattern of o-Ethylphenol Thermolysis in Dodecane

As stated earlier, the main product of pure OEP thermolysis is phenol, a deethylation product; para and meta isomers of ethylphenol, two isomerization products, are next important. A certain amount of isomeric cresols were also formed, either as demethylation products of the ethylphenols, or as isomerization products from other cresols. The

TABLE XII
FIRST ORDER RATE COEFFICIENTS OF DODECANE CONVERSION

| Run No. | Reactant | Temperature (K) | Pressure (MPa) | Environment | Rate Coefficient (s ⁻¹) | Correlation Coefficient r |
|---------|-------------------|--------------------|-------------------|----------------|---|---------------------------------|
| 7 & 12 | Dodecane | 623 | 9.2 | N ₂ | 4.7x10 ⁻⁷ | 0.9887 |
| 13 | Dodecane | 673 | 9.2 | N ₂ | 2.3x10 ⁻⁵ | 0.9855 |
| 14 | Dodecane | 623 | 9.2 | H ₂ | 1.7x10 ⁻⁷ | 0.9829 |
| 6 | Dodecane with OEP | 623 | 9.2 | N ₂ | 2.5x10 ⁻⁷ | 0.7515 |
| 8 | Dodecane with OEP | 648 | 9.2 | N ₂ | 1.1x10 ⁻⁶ | 0.9804 |
| 4 | Dodecane with OEP | 673 | 9.2 | N ₂ | 1.8x10 ⁻⁵ | 0.9422 |
| 5 | Dodecane with OEP | 673 | 7.0 | N ₂ | 1.8x10 ⁻⁵ | 0.9929 |
| 9 | Dodecane with OEP | 623 | 4.7 | N ₂ | 2.2x10 ⁻⁷ | 0.9744 |
| 21 | Dodecane with OEP | 623 | 9.2 | H ₂ | 8.7x10 ⁻⁸ | 0.9803 |
| 10 | Dodecane with OEP | 623 | 9.2 | H ₂ | 1.6x10 ⁻⁷ | 0.8907 |
| 20 | Dodecane with OEP | 623 | 15.6 | H ₂ | 9.6x10 ⁻⁸ | 0.9791 |

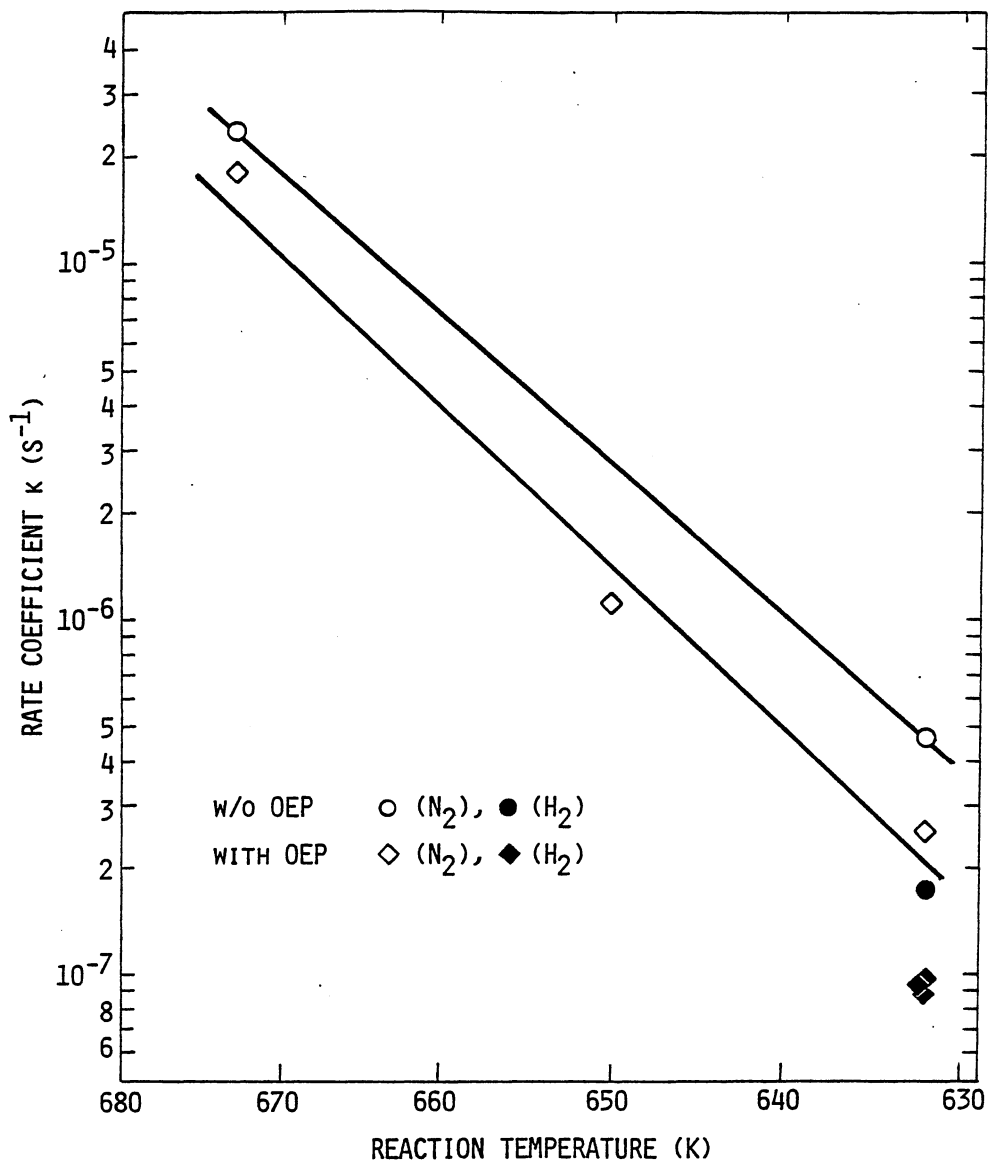

Figure 40. Arrhenius Plot of Dodecane Thermolysis

third class of reaction products of OEP conversion are aromatics, in small quantities, which must be the deoxygenation products from corresponding phenols. Another important class of products are heavier oxygen compounds as the condensation or alkylation products of oxygen-containing radicals and hydrocarbon radicals, most probably ethyl. These condensation products have a total yield close to that of p- and m-ethylphenols. Different environments seem to have no significant influence on either conversion or product yield pattern for pure OEP thermolysis, except less condensation products were found in the liquid samples in hydrogen environment, which is explained, in the last section, by the radical capping function of hydrogen.

For comparison purposes, relative product yields for the thermolytic reaction runs of OEP in solvent are calculated and summarized in Table XIII, corresponding data for pure OEP thermolysis are also listed in parallel.

As a whole, with solvent dodecane, OEP thermal cracking gives much more aromatics, more o-cresol, and much less phenol. Yields of p- and m-ethylphenols are also lower. Under nitrogen, it produces even less phenol and much more heavy products than the experiment without solvent does. Nevertheless, under hydrogen, the para and meta cresols vanish completely. Yields of heavy compounds are reduced drastically and essentially disappear at a hydrogen pressure of 15.6 MPa (Table XXXVIIIb).

These differences should undoubtedly be attributed to the role played by the solvent. Referring to the free radical chain reaction mechanism proposed for dodecane cracking and suggested mechanism of essentially homolytic unimolecular decomposition with very short

TABLE XIII
 PRODUCTS FROM o-ETHYLPHENOL THERMOLYSIS IN DODECANE

| Run number | o-Ethylphenol in dodecane | | | | | | | Pure o-ethylphenol | |
|--|---------------------------|----------------|----------------|----------------|----------------|----------------|----------------|--------------------|----------------|
| | 6 | 8 | 4 | 5 | 9 | 10 | 21 | 15 | 16 |
| Temperature (K) | 623 | 648 | 673 | 673 | 623 | 623 | 623 | 623 | 623 |
| Pressure (MPa) | 9.2 | 9.2 | 9.2 | 7.0 | 4.7 | 9.2 | 9.2 | 9.2 | 9.2 |
| Environment | N ₂ | N ₂ | N ₂ | N ₂ | N ₂ | H ₂ | H ₂ | N ₂ | H ₂ |
| Reaction time (h) | 6.75 | 5.67 | 2.33 | 2.16 | 7.33 | 8.0 | 6.67 | 5.0 | 5.0 |
| Conversion (mol%) | 8.2 | 19.4 | 32.2 | 29.4 | 9.2 | 4.6 | 3.1 | 2.1 | 2.4 |
| Products (moles per 100 moles converted) | | | | | | | | | |
| Benzene | 9.2 | 4.5 | 3.1 | 3.8 | 5.3 | 12.3 | 10.5 | 0.1 | - |
| Toluene | 8.3 | 3.3 | 2.5 | 2.9 | 3.2 | 12.3 | 8.5 | 0.4 | 0.7 |
| Ethylbenzene | 12.5 | 3.4 | 1.6 | 1.6 | 17.4 | 16.5 | 6.8 | 0.1 | 0.2 |
| Phenol | 10.5 | 7.7 | 4.3 | 4.1 | 12.6 | 17.5 | 22.4 | 53.8 | 56.5 |
| o-Cresol | 5.5 | 6.2 | 10.0 | 9.7 | 6.0 | 7.2 | 6.8 | 1.5 | 1.1 |
| p-,m-Cresols | 2.9 | 4.6 | 6.4 | 6.3 | 3.2 | 0 | 0 | 3.9 | 3.4 |
| p-Ethylphenol | 4.1 | 4.9 | 3.4 | 2.8 | 5.1 | 9.4 | 12.2 | 14.4 | 14.2 |
| m-Ethylphenol | 2.2 | 3.7 | 2.0 | 2.4 | 2.6 | 9.4 | 5.1 | 8.0 | 9.7 |
| Xylenols + hydrocarbons | 18.8 | 27.4 | 30.0 | 32.6 | 13.4 | 7.2 | 12.2 | 0 | 0 |
| Heavy O-compds + hydrocarbons | 23.9 | 34.2 | 36.6 | 33.5 | 31.1 | 8.1 | 15.6 | 17.8 | 14.2 |

reaction chain for OEP thermolysis, the reaction mechanism for the solute and solvent together is complicated. Since OEP is in only small concentration, around 5 mol%, OEP molecules are surrounded by dodecane molecules and the radicals formed from dodecane thermolysis. These radicals abstract hydrogen atoms from OEP molecules, creating more radicals from ethylphenol. A considerable part of them, according to the reaction scheme presented in section C.4, undergo coupling reactions with hydrocarbon radicals forming heavier oxygen compounds. This explains the formation of a large amount of heavy components during OEP thermolysis in the presence of the solvent. Furthermore, the phenol-derived radicals, formed either from homolytic decomposition of OEP molecules or from o-ethylphenol radical decomposition, instead of abstracting hydrogen atoms from other molecules and stabilizing themselves as in the case of pure OEP cracking, will have more chance to react with surrounding hydrocarbon radicals, mostly larger than ethyl, thus terminating the chain and forming more heavy oxygen compounds. This contributes to further increase of alkylation products and also to the reduction of phenol yield.

As interpreted in the reaction mechanism suggested for OEP thermolysis, the isomerization of ethylphenols proceeds partly via recombination of hydroxyphenyl radicals with ethyl radicals. In the presence of a large quantity of the solvent molecules, part of the ethyl radicals abstract hydrogen atoms from dodecane molecules and become ethane, the rest of them, greatly diluted by dodecane molecules, have much less chance to react with hydroxyphenyl radicals to form p- and m-ethylphenols. As a result, yields of p- and m-ethylphenols decrease appreciably.

The difference in the yields of arenes between OEP thermolysis with and without the solvent needs more discussion. Possibly owing to the different phase equilibrium conditions between an oxygen-compound system and hydrocarbon system, certain amounts of arenes enter the gas phase in the case of pure OEP thermolysis (Table XXIX). This implies that the practical yields of arenes of Runs 15 and 16 are higher than those listed in Table XIV. Merely comparing the strengths of C-C and C-O bonds is not sufficient to explain the quantities of arenes produced. Cypres and Bettens (1974, 1975a,b), Hedaya and Kent (1971), Spielman and Cramers (1972) and Braekman-Danheux et al. (1977) explained the formation of arenes from o-cresol pyrolysis via the reaction route of ring expansion. This may account for the aromatic hydrocarbons generated in larger amounts than expected from simple bond energy consideration. Also this kind of ring expansion may be favored in hydrocarbon environment so that more arenes are produced from OEP thermolysis in dodecane.

The picture described above implies that the increase in OEP conversion in the presence of a hydrocarbon solvent is due principally to the promotion of ethylphenol radical formation, and the enhancement in condensation/alkylation reactions, by hydrocarbon radicals. Higher molecular weight oxygen compounds are formed with a sacrifice in the yields of phenol and isomeric ethylphenols. Hence, substituted phenols, while co-existing with hydrocarbons, are more likely to form high molecular weight products during thermal treatment, and if conditions are severe enough and conversion high enough, more prone to carbonaceous materials formation.

The most pronounced effect of the hydrogen environment is the drastic reduction in the yield of condensation products. The radical capping mechanism works here as well. Molecular hydrogen, dispersed in the liquid phase, caps the radicals and thus suppresses the condensation. The radical capping function of hydrogen works of course indiscriminately, it captures whatever radical it contacts. Dodecane thermolysis, occurring through a free radical chain reaction mechanism, is sure to be influenced by this capping of radicals which cuts the chain length short and hence reduces the reaction rate. This is evidenced in dodecane thermolysis experiments discussed in Section B. Thermolytic reactions of pure OEP proceed by homolytic dissociation with only a short chain length, as suggested in this work, and are accordingly affected to a very small extent, as is the case with Runs 15 and 16. In these two runs, hydrogen participant reduces the yield of condensation products to a certain degree but does not cause significant decrease in conversion. Seemingly different effects of the hydrogen atmosphere upon dodecane and OEP cracking thus acquire a reasonably good explanation.

When OEP and dodecane are thermolyzed together, hydrogen plays its part by capping hydrocarbon radicals, mostly formed through dodecane cracking, as well as oxygen-containing radicals, generated from OEP thermolysis. In this way, not only are the thermal reactions of dodecane suppressed, as a result, the enhancing effect of hydrocarbon radicals on OEP reactions is also reduced. Consequently, condensation reactions are inhibited and overall conversion of OEP decreases.

Temperature affects the product distribution yields. Yields of arenes and phenol decrease, while yields of cresols increase with

increasing temperature, as shown in Table XIV. The cleavage of methyl group from the side chain of OEP seems to be favored by higher temperature. The isomerization of ethylphenol is not greatly influenced by temperature in the range studied, but is favored by the presence of hydrogen. The reason why p- and m-cresols vanish in hydrogen runs is not clear.

D.6. Gas Analysis

Gas analysis results of some OEP runs are listed in Tables XXVIII and XXXIX (Appendix B) and plotted in Figure 41. In this figure, molar ratios of $(C_2 + C_2^=)/C_1$ in gas composition and phenol/cresols in the liquid products are plotted in order to show stoichiometric relations between them.

The molar ratios $(C_2 + C_2^=)/C_1$ in the gases, either for 623 K runs (Runs 15, 16 and 21) or for the 673 K run (Run 5), either under nitrogen (Runs 15 and 5), or under hydrogen environment (Run 21), with solvent (Runs 5 and 21), or without (Runs 15 and 16), all concentrate in a narrow region. For liquid samples from Runs 15 and 16, the molar ratios of phenol/cresols are much higher than those for the corresponding gas $(C_2 + C_2^=)/C_1$ values. An explanation has been given that during pure OEP thermolysis, part of the ethyl radicals produced undergo coupling reaction rather than hydrogen abstraction with OEP.

In the presence of solvent dodecane, the molar ratios of phenol/cresols in the liquid samples are close to the corresponding gas $(C_2 + C_2^=)/C_1$ ratios (623 K runs) and for 673 K run No. 5, are even lower. Of course, part of the gases are produced by dodecane cracking which brings along some uncertainty. From Table XXV, $(C_2 + C_2^=)/C_1$

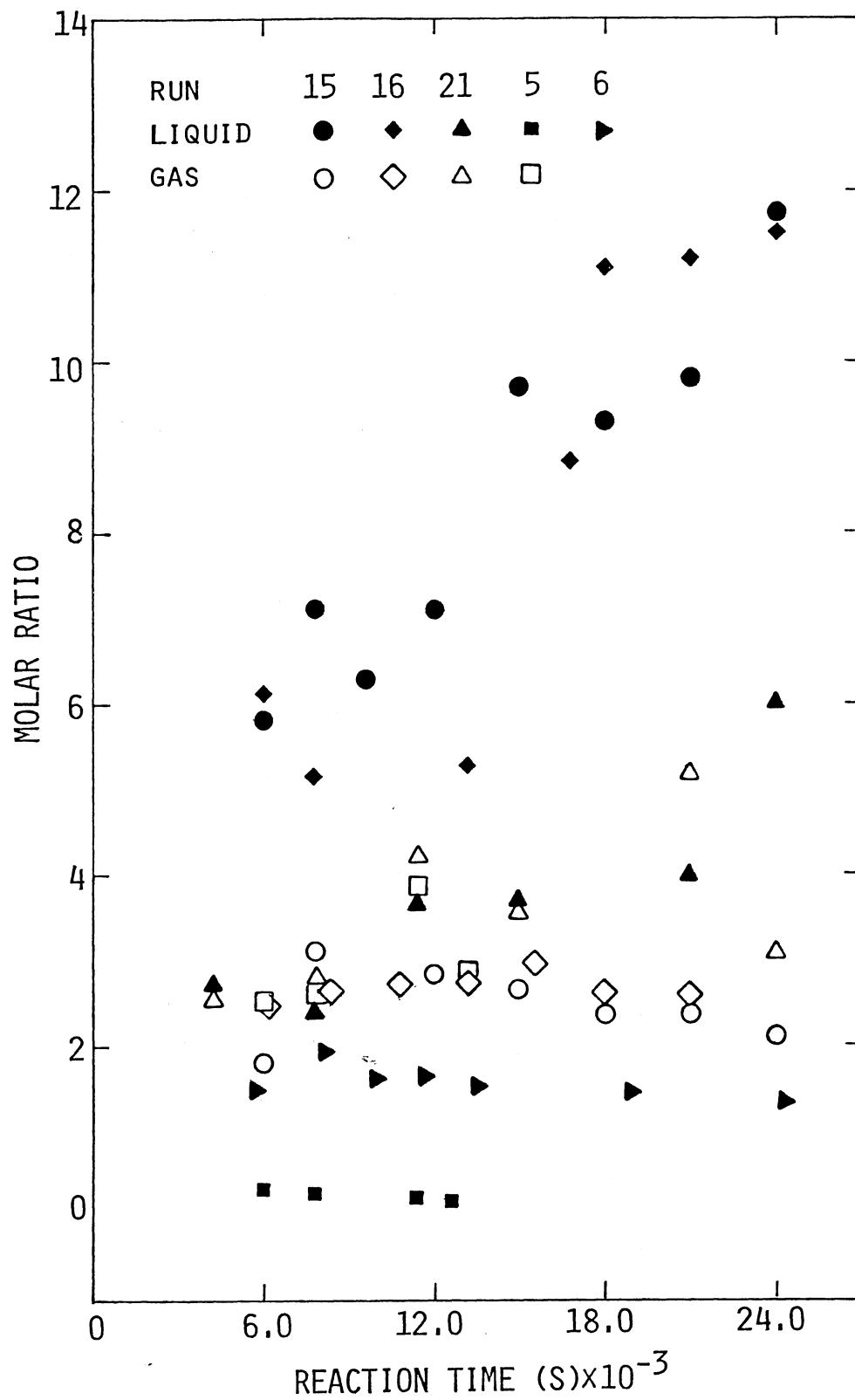

Figure 41. Molar Ratios $(C_2 + C_2^-)/C_1$ and Phenol/Cresols in o-Ethylphenol Thermolysis Products

values for pure dodecane thermolysis happen to be close (3.1 - 5.8) to the narrow range just mentioned. This gives us reason to suggest that the reduction of phenol/cresols ratio while OEP IS thermolyzed with dodecane is due to loss of phenol radicals in coupling with hydrocarbon radicals provided by the solvent. This argument further supports the mechanism described in the last section.

D.7. Mutual Influence of o-Ethylphenol and Dodecane during Thermolysis

There are evidences that OEP and the solvent do affect each other in their cracking behaviors. The mechanism for this mutual effect has been described in the previous sections; a summary of this mutual influence is given below.

Firstly, the overall reaction of OEP was accelerated by the presence of dodecane. This is clearly demonstrated by the data in Table XII (Section D.2). The rate coefficient of OEP thermolysis at 623 K, 9.2 MPa, under either nitrogen or hydrogen atmosphere, was raised by a factor of 2.6. On the contrary, the overall reaction rate of dodecane was decreased by a factor of about 2 in the presence of OEP, as shown in Table XIII (Section D.4). Evidently, OEP thermolysis is accelerated by dodecane, but thermolysis of the latter is inhibited by the oxygen compound, o-ethylphenol. Under the same conditions, 623 K, 9.2 MPa, N₂, the rate coefficient of pure OEP thermolysis is already higher than that of pure dodecane cracking, and OEP thermolysis is further accelerated by the free radicals formed through dodecane cracking. As a reverse effect, OEP scavenged part of the hydrocarbon radicals and thus retarded dodecane thermolysis.

Secondly, the co-existence of OEP and n-C₁₂ altered the product distribution pattern of cracking to some extent. Individual product yields of Runs 6, 12 and 15 are further compared in Figures 42 through 46.

Clearly, less phenol was formed during thermolysis in the solvent, less p- and m-ethylphenols, and somewhat more o-cresol resulted. Importantly, a drastic increase in condensation products was observed. The yield of condensation products for OEP + dodecane thermolysis (Run 6) is about three times that of pure OEP cracking (Run 15), and approximately two times that obtained in pure dodecane cracking (Run 12). The synergetic effect of OEP and dodecane produced much more high-molecular-weight products than they would have alone.

As to hydrocarbon products, more C₉ + C₉[≡], C₁₀ + C₁₀[≡] and C₁₁ + C₁₁[≡] but less > C₁₂ were observed, compared to only dodecane being cracked.

Most of the observations can be satisfactorily explained by the mechanism proposed in the previous subsections.

E. Thermolytic Reactions of p- and m-Ethylphenols

In order to compare the thermal reactivities of three different isomeric ethylphenols, p- and m-ethylphenols in dodecane were treated in the same manner as o-ethylphenol. Analytical results of liquid and gas samples collected from these three runs (Runs 17, 18 and 19) are summarized in Tables XL to XLIII (Appendix B). p-Ethylphenol (PEP) was only run under nitrogen, but m-ethylphenol (MEP) was run both under nitrogen and hydrogen to investigate the influence of different environments.

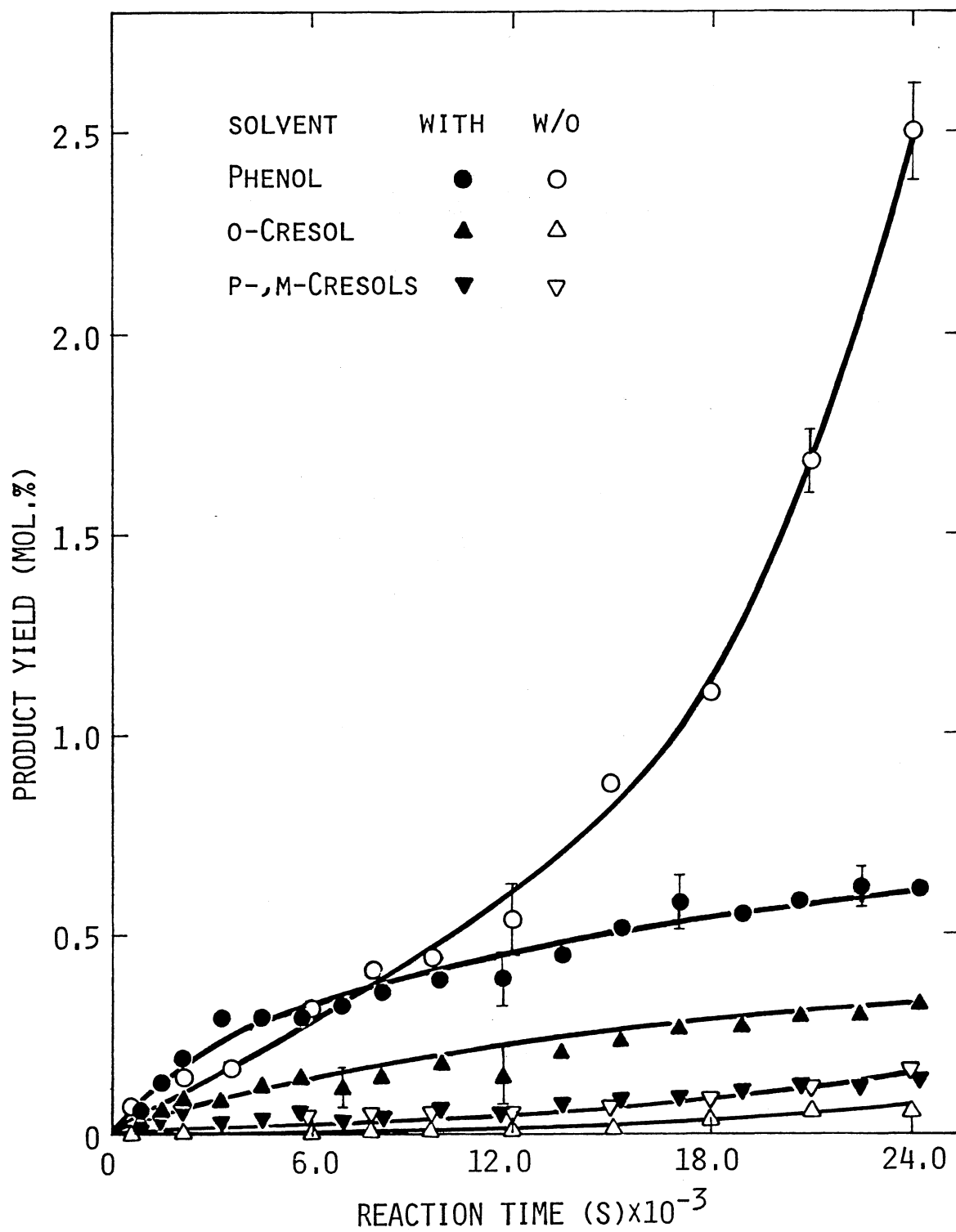

Figure 42. Mutual Influence of o-Ethylphenol and Dodecane Thermolysis (1)

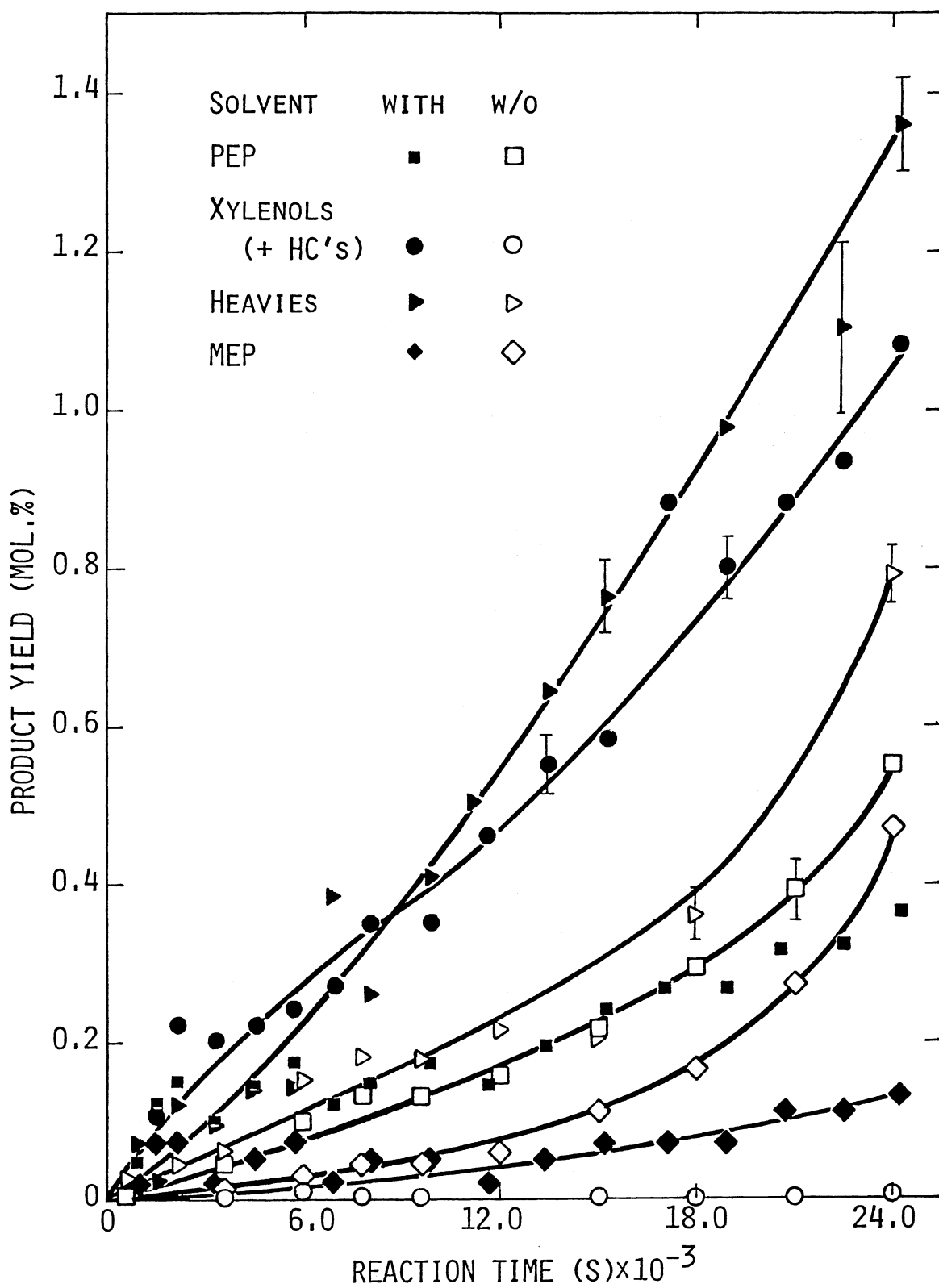

Figure 43. Mutual Influence of *o*-Ethylphenol and Dodecane Thermolysis (2)

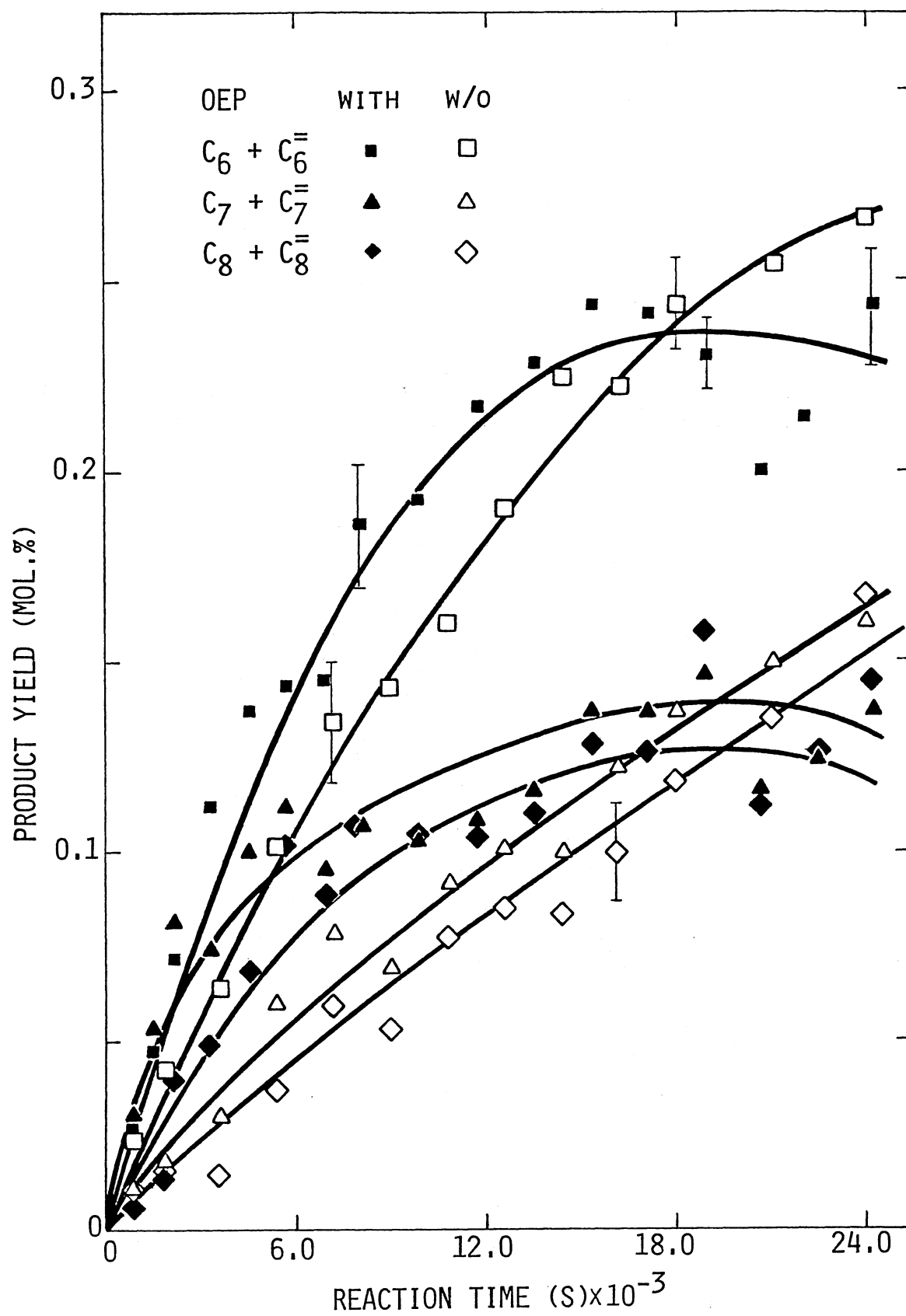

Figure 44. Mutual Influence of o-Ethylphenol and Dodecane Thermolysis (3)

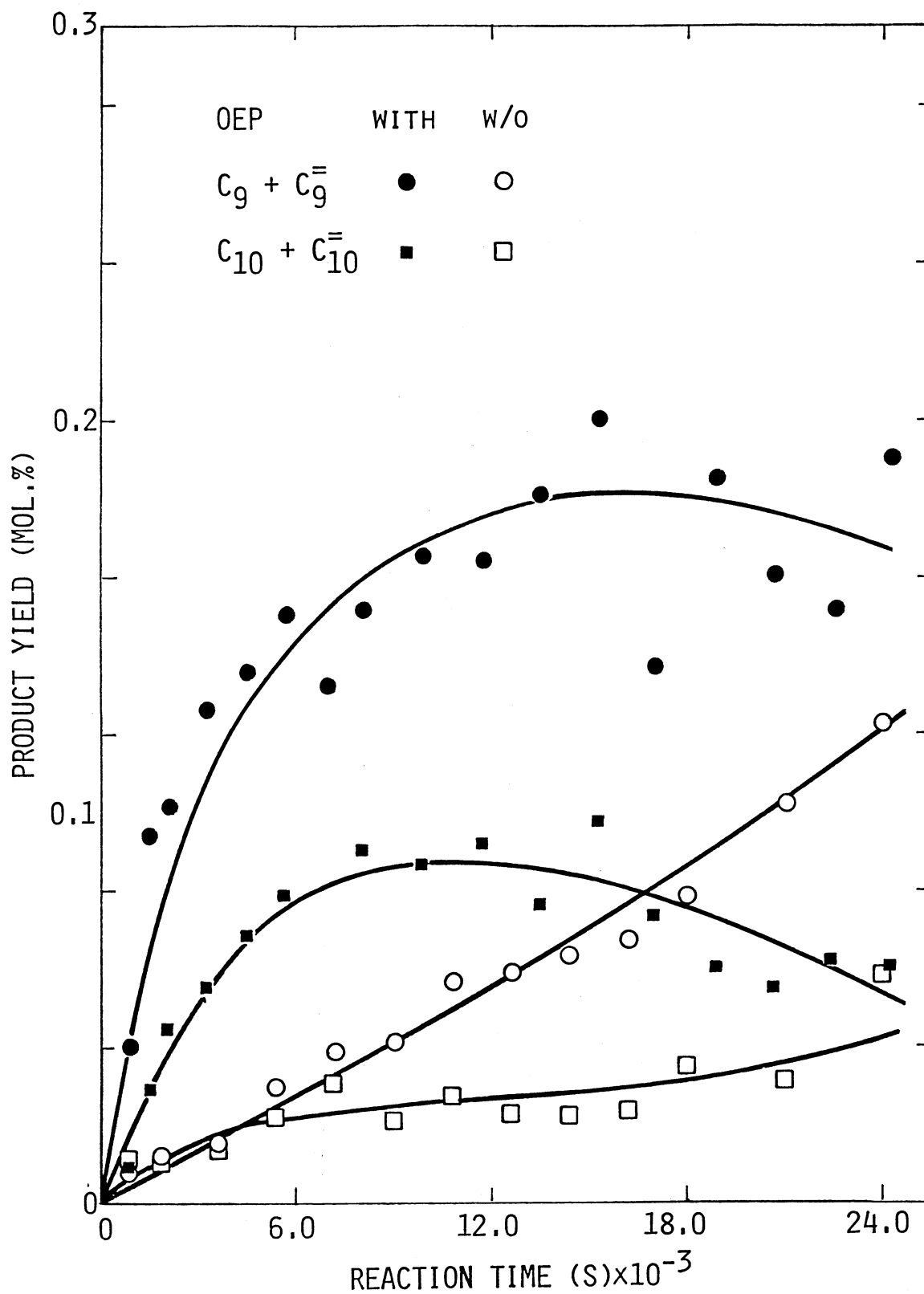

Figure 45. Mutual Influence of o-Ethylphenol and Dodecane Thermolysis (4)

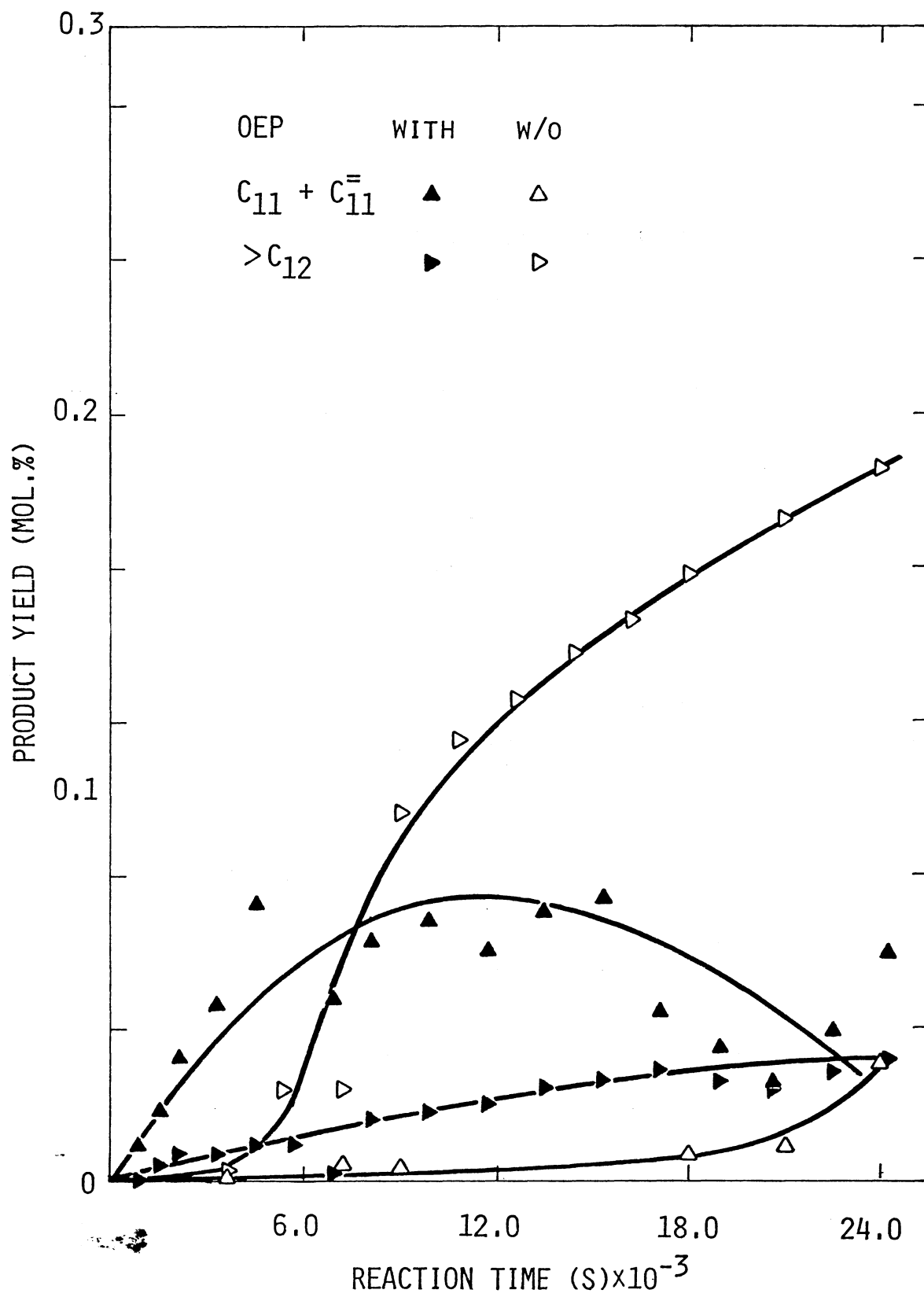

Figure 46. Mutual Influence of o-Ethylphenol and Dodecane Thermolysis (5)

E.1. Thermolysis of p-Ethylphenol in Dodecane

The thermal cracking of PEP gave ortho and meta isomers as main products. Much less phenol was obtained. A distinct feature is the essential absence of cresols. Heavy products account for about one third of the isomeric ethylphenols. Arenes were formed in certain amounts.

First order kinetics fits PEP disappearance also. The rate constant for PEP conversion at 623 K, 9.2 MPa, N₂ is calculated to be $1.4 \times 10^{-6} \text{ (s}^{-1}\text{)}$, lower than the corresponding value for OEP. We will discuss the mechanism after a comparison has been made between the three isomers.

E.2. Thermolysis of m-Ethylphenol in Dodecane

Under nitrogen pressure 9.2 MPa and 623 K, MEP thermolysis produces about the same amounts of phenol and heavy compounds, but less arenes and much less isomeric ethylphenols, as compared with PEP cracking. Very small quantities of cresols were detected in the liquid.

Hydrogen atmosphere reduced MEP conversion under otherwise identical conditions. Phenol and arenes were formed without much difference in the nitrogen environment. However, isomeric ethylphenols were not formed and heavy compounds were reduced significantly.

First order kinetics holds for both environments with a rate coefficient in hydrogen half as much as that in nitrogen (Table XV).

E.3. Comparison of Thermolytic Behaviors of the Three Isomeric Ethylphenols

Kinetic constants of thermolysis of the three isomeric ethylphenols with solvent are summarized in Table XIV. Rate coefficients for dodecane are also included for reference.

Under same conditions, 623 K, 9.2 MPa, N₂, OEP has the highest rate constant, and MEP the least, with PEP in between. With cresols, the ease of dehydroxylation has been found to be in the order o > p > m (Gonikberg and Li, 1960b). In our case, at least the overall conversion of the isomeric ethylphenols follows this same order. No attempt was made to go further into the theory of chemical structures, but a speculation can be made based on the ortho-para directing property of the OH group (Pauling, 1960, p. 207). The strong resonance effect of the OH group may cause the para and ortho substituents easier to cleave off, the ortho-ethyl side chain, being closer to the OH group, tends to be removed more readily.

Products from the three runs are compared in Figures 47 and 48. OEP produces more phenol, the amount being reduced by hydrogen pressure, and PEP and MEP give less phenol. In most cases, OEP yields these products in the largest amount. PEP produces more isomeric ethylphenols, and MEP gives more cresols. All products, especially heavy ones, are suppressed by hydrogen.

Also shown in Table XIV, dodecane cracking is inhibited by all three ethylphenols. The rate coefficient of dodecane thermolysis (623 K, 9.2 MPa) is reduced to about the same extent, showing essentially the same inhibition effect with each ethylphenol. The inhibition is even more pronounced in hydrogen environment.

TABLE XIV
FIRST ORDER RATE COEFFICIENTS FOR THE THERMOLYSES OF ISOMERIC ETHYLPHENOLS IN DODECANE

| Run No. | Reactant | Temperature (K) | Pressure (MPa) | Environment | Rate Coefficient (s ⁻¹) | Correlation Coefficient r |
|---------|---------------------------|--------------------|-------------------|----------------|---|---------------------------------|
| 3 & 6 | o-Ethylphenol in dodecane | 623 | 9.2 | N ₂ | 4.1x10 ⁻⁶ | 0.9466 |
| 10 & 21 | o-Ethylphenol in dodecane | 623 | 9.2 | H ₂ | 1.7x10 ⁻⁶ | 0.9317-0.9915 |
| 17 | p-Ethylphenol in dodecane | 623 | 9.2 | N ₂ | 1.3x10 ⁻⁶ | 0.9906 |
| 18 | m-Ethylphenol in dodecane | 623 | 9.2 | N ₂ | 7.0x10 ⁻⁷ | 0.9804 |
| 19 | m-Ethylphenol in dodecane | 623 | 9.2 | H ₂ | 3.1x10 ⁻⁷ | 0.9558 |
| 6 | Dodecane with OEP | 623 | 9.2 | N ₂ | 2.5x10 ⁻⁷ | 0.7517 |
| 10 & 21 | Dodecane with OEP | 623 | 9.2 | H ₂ | 1.2x10 ⁻⁷ | 0.8907-0.9803 |
| 17 | Dodecane with PEP | 623 | 9.2 | N ₂ | 1.8x10 ⁻⁷ | 0.9757 |
| 18 | Dodecane with MEP | 623 | 9.2 | N ₂ | 1.9x10 ⁻⁷ | 0.9517 |
| 19 | Dodecane with MEP | 623 | 9.2 | H ₂ | 1.1x10 ⁻⁷ | 0.8945 |

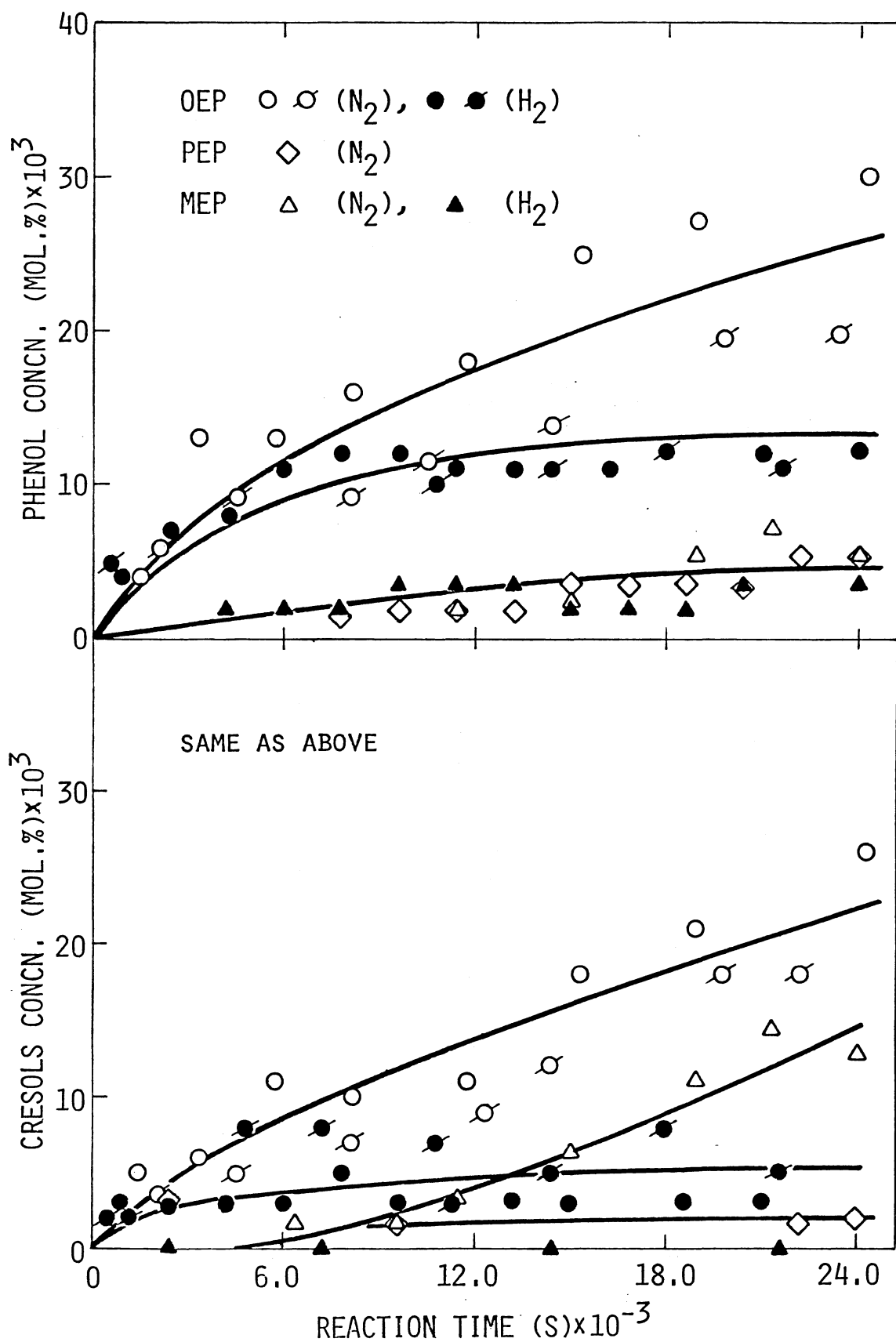

Figure 47. Comparison of Thermolytic Reaction Products of Isomeric Ethylphenols (1)

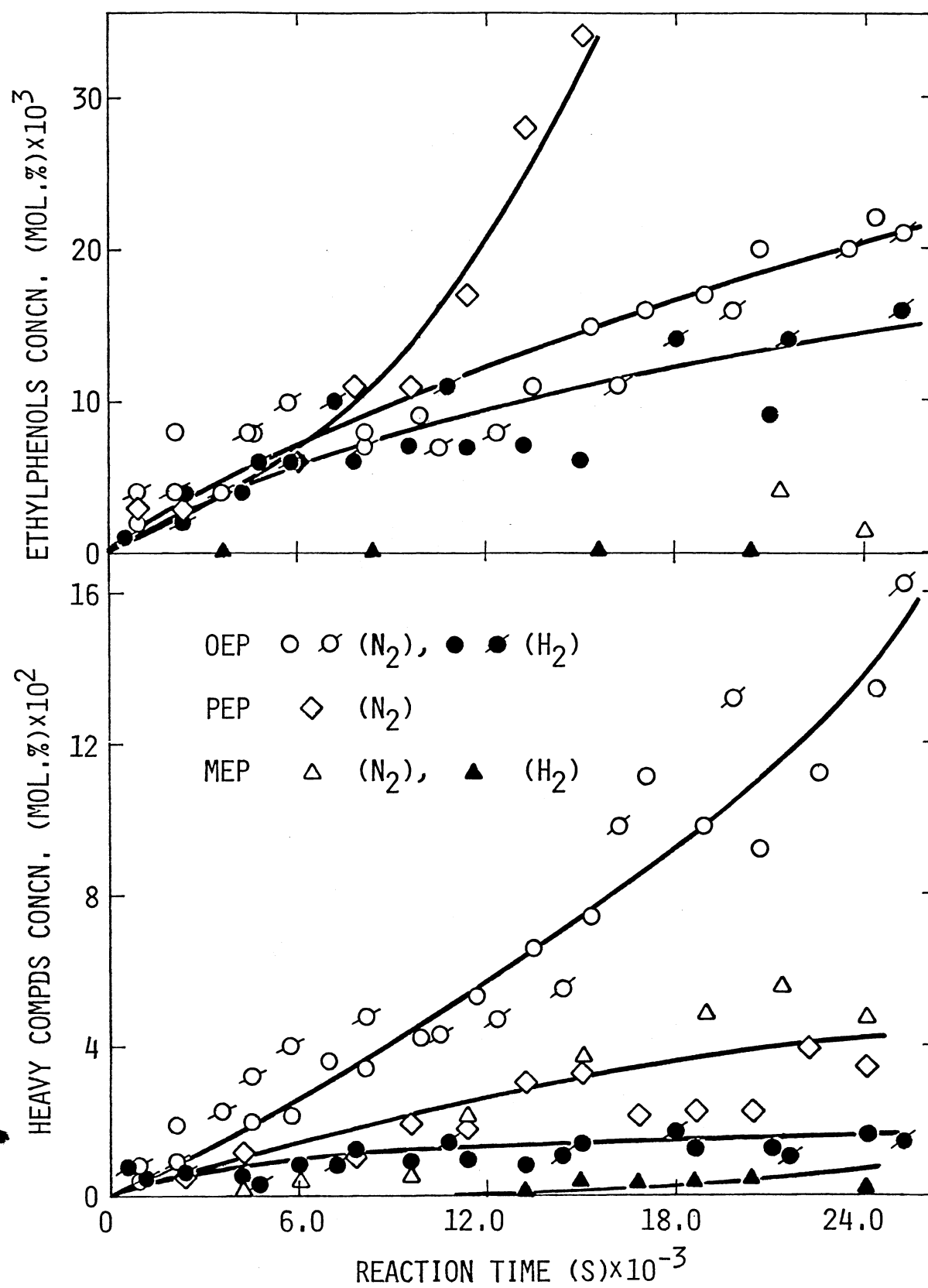

Figure 48. Comparison of Thermolytic Reaction Products of Isomeric Ethylphenols (2)

We believe that thermolysis of all three ethylphenols has basically the same mechanism. In other words, under present conditions, they dissociate mainly by homolytic scission of the C-C bonds related to the side chains, the radicals that are formed undergo further reactions.

From the gas analysis data in Table XLIII, the molar ratios of $(C_2 + C_2^=)/C_1$ for PEP and MEP thermolysis are lower than that in OEP thermolysis (1-2 versus 4-6). This suggests that in PEP and MEP cracking more cleavage occurs in the middle of the side chain than in OEP cracking, hence lower yields of phenol are observed.

OEP, although more easily cracked, also tends to form more heavy products.

CHAPTER VI

CONCLUSIONS AND RECOMMENDATIONS

This study has consisted of an investigation of thermolytic reactions of three isomeric ethylphenols in an hydrocarbon solvent, under various conditions and environments. In particular, thermolysis of o-ethylphenol was investigated in detail and that of dodecane, as a solvent background, was also examined.

From this experimental work, relevant kinetic data were obtained and the following conclusions reached:

1. Dodecane thermolysis proceeds via a free radical chain reaction mechanism with unimolecular initiation and β_{μ} termination. A pseudo first order rate law applies to its overall conversion; kinetic parameters such as rate coefficients, activation energy and frequency factor have been achieved and are reasonable compared to available literature data for other alkanes. Dodecane is relatively refractory under temperatures below 623 K and a reaction time less than 1-2 hours, but if used as a carrier solvent under more severe conditions, its reactions should be taken into account as a background.

A whole range of C_1 - C_{22} mostly straight-chain products, with C_{13} missing, are obtained in dodecane thermolysis. High reaction pressure favors the formation of saturated hydrocarbons. Decreasing yields of individual hydrocarbons with increasing molecular weights are observed;

this fact suggests that the C-C bonds in dodecane are not uniform in strength.

Statistical calculations for the product distribution of dodecane cracking under high pressures, based on Rice-Kossiakoff theory, agree satisfactorily with the observed data if modifications are made regarding the relative thermal stabilities of paraffins of different molecular sizes.

2. Ethylphenols undergo thermolytic conversion mainly by unimolecular dissociation and subsequent reactions of the radicals formed. The length of the reaction chain is negligible. The most important reaction is cleavage of the C-C bonds to and in the side chain, producing phenol as the principal product and also cresols in small amounts. Isomerization is significant for ethylphenols and is also observed for cresols to a less extent. Arenes are formed as minor products, possibly through ring expansion. Appreciable amounts of heavier phenols were found in the reaction products as a result of coupling reactions of corresponding radicals.

The relative thermal reactivities of the ethylphenols are as follows: $o > p > m$. The overall conversions of the ethylphenols are best described by pseudo first order kinetics. Kinetic constants are obtained and are reasonable referring to the data for other phenols recorded in the literature. A reaction network is proposed.

3. Mutual influences between the ethylphenols and the paraffin solvent were evidenced in this work. They are obviously related to the respective thermolysis mechanisms of ethylphenols and dodecane. Thermal conversion of the ethylphenols is enhanced by the presence of the hydrocarbon solvent, more oxygen compound radicals being created and

participating in the coupling reactions. As a result, more heavy products are formed at the sacrifice of the low-molecular-weight products. Therefore, substituted phenols can be partly converted to smaller phenols and deoxygenated to aromatic hydrocarbons by thermal treatment, but they show more tendency to be potential sources of carbonaceous materials in the presence of heavy hydrocarbons.

As a reverse effect, the ethylphenols inhibit dodecane thermolysis by scavenging hydrocarbon radicals. This is consistent with the well known behavior of phenols as oxidation inhibitors.

4. Molecular hydrogen plays a certain role in thermolytic reactions of ethylphenols and dodecane in the system and under conditions used in this investigation. This effect is possibly related with radical capping in the reaction system. Consequently, the thermal reaction chain of dodecane is cut short and conversion reduced in a hydrogen environment, while overall disappearance of pure o-ethylphenol is not considerably affected except for some suppression of condensation/alkylation reactions. For the thermolysis of ethylphenol-dodecane solutions, hydrogen suppresses dodecane cracking and thus cancels, to some extent, the enhancing effect of hydrocarbon radicals on ethylphenol conversion. Hence, thermal hydrotreatment of substituted phenols in hydrocarbons under severe conditions may provide partial elimination of the oxygen compounds without generating much high-molecular products.

5. Regression analysis performed for concentration versus reaction time data for each of the experimental runs shows that a correlation factor is not a good criterion for the determination of reaction order which has been a common practice. The estimated variance, $s_{y,x}^2$,

involved with the calculated value as an estimate of the rate coefficient, should be used in addition.

6. The apparatus and procedures employed in this work satisfactorily combine relative ease of operation and data accuracy. The rate constants reported here have a standard deviation of 10-35% for dodecane cracking and 24% for ethylphenol thermolysis.

7. The uniqueness of this study consists of the following aspects:

i) the batch reactor system is equipped with devices for successive sampling so that the entire reaction process is monitored;

ii) the thermolytic reactions of ethylphenols, as representatives of the oxygen compounds in coal-derived liquids, and of dodecane, as a solvent background, are investigated in detail for the first time;

iii) the participation of molecular hydrogen in certain reactions involving free radicals under certain conditions is elucidated. This contributes to the scarce information regarding this topic as recorded in the literature.

iv) by studying the ethylphenols and dodecane, separately and in mixture, the mutual influence of the substrate and the solvent is revealed so that their thermolytic behaviors can be clearly understood without confusion. This calls the attention of the researchers to the necessity of considering the solvent effect in kinetic studies; and

v) a reasonable method for the determination of reaction order by means of data regression using the estimated variance $s_{y,x}^2$ as a criterion is used and suggested.

From the present study, the following recommendations are made as guidelines for future work:

1. As discussed in Section A of the previous chapter, the inaccuracy of the data mainly arises from the liquid holdup by the surfaces of the sampling lines and from the vaporization loss during liquid-sample analysis. A microreactor with on-line GC analysis would improve accuracy of the data.

2. A study of thermolytic reactions of benzo- and dibenzo-furans, the second important oxygen compounds in coal-derived liquids, and of mixtures of phenols and furans will further illuminate the complicated chemistry of oxygen compounds in coal-derived liquids.

BIBLIOGRAPHY

- Aczel, T., and Lumpkin, H. E. (1979). Petrol. Prepr.* 24, 955; also (1979). Adv. Chem. Ser. 179 (Refining of Synthetic Crudes), 13.
- Aczel, T., Williams, R. B., Brown, R. A., and Pancirov, R. J. (1978). In "Analytical Methods for Coal and Coal Products", Vol. 1 (C. Kerr, Jr., ed.), Academic Press, New York, p. 499.
- Aczel, T., Williams, R. B., Chamberlain, N. F., and Lumpkin, H. E. (1981). Adv. Chem. Ser. 195 (Chemistry of Asphaltenes), 237.
- Albright, L. F. (1978). Ind Eng. Chem., Process Des. Dev. 17, 377.
- Albright, L. F. and Tsai, T. C. H. (1983). In "Pyrolysis: Theory and Industrial Practice" (L. F. Albright, B. L. Crynes, and O. Dermer, eds.), Chapter 10, Academic Press, New York.
- Alekseeva, K. A., and Moldavskii, B. L. (1959). Khim. Tekhnol. Topliv Masel 4, No. 1, 43; C. A. 53, 10104.
- Aly, M. M., Badr, M. Z. A., Fahmy, A. M., and Mahgaub, S. A. (1983). Can. J. Chem. 61, 1532.
- Armstrong, L. (1982). Fuel, 61, 1051.
- Asim, M. Y., Desai, P. H., Plantenza, F. L., and Sonnemans, J. W. M. (1983). 'Hydrotreating of SRC-I Naphtha', presented at AIChE Meeting, Houston, TX, 3/27-3/31.
- Baltisberger, R. J., Klabunde, K. J., Stenberg, V. I., Woolsey, N. F., Saito, K., and Sukaliki, W. (1978). ACS Symp. Ser. 71 (Organic Chemistry of Coal), 294.
- Baltisberger, R. J., Klabunde, K. J., Woolsey, N. F., and Severson, D. E. (1979). 'Application of Liquefaction Process to Low-Rank Coals', Symp. on Technol. and Use of Lignite, Grand Folks, N.D., May.

* To save space, the following abbreviations are used for certain much-cited journals:

| | |
|-----------------------|--|
| <u>Fuel Prepr.</u> | <u>American Chemical Society, Division of Fuel Chemistry, Preprints</u> |
| <u>Petrol. Prepr.</u> | <u>American Chemical Society, Division of Petroleum Chemistry, Preprints</u> |
| <u>C. A.</u> | <u>Chemical Abstracts</u> |

- Baltisberger, R. J., Patel, K. M., Wettlaufer, D. G., Rovang, J. W., Woolsey, N. F., and Stenberg, V. I. (1981a). Fuel Prepr. 26 (2), 38.
- Baltisberger, R. J., Klabunde, K. J., Stenberg, V. I., and Woolsey, N. F. (1981b). Abstracts and Research Accomplishments of AR&TD Coal Liquefaction Projects, U.S. Dept. Energy, p. 65.
- Bartle, K. D., Martin, K. G., and Williams, D. F. (1975). Fuel 54, 226; also (1975) Chem. Ind. (London), 313.
- Bartle, K. D., Ladner, W. R., Martin, T. G., Snape, C. E., and Williams, D. F. (1979). Fuel 58, 413.
- Becker, M., Bendoraitis, J. G., Bloch, M. G., Cabal, A. V., Callen, R. B., Green, L. A., and Simpson, C. A., Report U.S. DOE FE-2676-1; Energy Res. Abstr. 5, 2428.
- Benjamin, B. M., Raaen, V. F., Kabalka, C. W., and Collins, C. J. (1977). Fuel Prepr. 22 (2), 206.
- Benjamin, B. M., Raaen, V. F., Maupin, P. H., Brown, L. L., and Collins, C. J. (1978). Fuel 57, 269.
- Bertolacini, R. J., Gutberlot, L. C., Kim, O. K., and Robinson, K. K. (1979). Electric Power Research Institute Report AF1084.
- Bobyshev, V. I., D'yakova, M. K., and Lozoval, A. V. (1940). J. Appl. Chem. (U.S.S.R.) 13, 942; C. A. 35, 2060.
- Bockrath, B. C., and Noceti, R. P. (1979). Fuel Process. Technol. 2, 143.
- Bockrath, B. C., and Schweighardt, F. K. (1979). Fuel Prepr. 24 (2), 949.
- Bockrath, B. C., and Schweighardt, F. K. (1981). Adv. Chem. Ser. 195 (Chemistry of Asphaltenes), 29.
- Bockrath, B. C., Delle Donne, C. L., and Schweighardt, F. K. (1978). Fuel 57, 4.
- Boduszynski, M. M., Hurtubise, R. J., and Silver, H. F. (1982). Anal. Chem. 54, 375.
- Bodzek, D., and Marzec, A. (1980). Fuel Prepr. 25 (2), 195; also (1981) Fuel 60, 47.
- Bodzek, D., Krzyzanowska, T., and Marzec, A. (1979). Fuel 58, 196.
- Braekman-Danheux, C., and Heyvaert, A. (1972). Ann. Mines Belg. (1), 37; C. A. 77, 4666.

- Braekman-Danheux, C., Delannois, C., and Quyen, N. C. (1977). Fuel Proc. Technol. 1, 57.
- Bredael, P., Vinh, T. H., and Braekman-Danheux, C. (1983). Fuel, 62, 1193.
- Bredenberg, J. B., and Ceylan, R. (1983). Fuel 62, 342.
- Bredenberg, J. B., Huuska, M., Raty, J., and Karpio, M. (1982). J. Catal. 77, 242.
- Brower, K. R. (1977). Fuel 56, 245.
- Bruecker, R., and Koelling, G. (1965). Brennstoff-Chem. 46, 41.
- Burke, F. P., Winschel, R. A., and Pochapsky, T. C. (1981). Fuel Prepr. 26 (2), 68; and (1981). Fuel 60, 562.
- Carson, D. W., and Ignasiak, B. S. (1980). Fuel 59, 757.
- Cawley, C. M., Carlile, J. H. G., Newall, H. E., and Kingman, F. E. T. (1946). J. Inst. Petrol. (London) 32, 660.
- Ceylan, R., and Bredenberg, J. Bson. (1982). Fuel 81, 377.
- Chan, W. S., Seapan, M., Crynes, B. L., and Al-Shaieb, Z. (1982). Petrol. Prepr. 27, 816.
- Cogswell, T. E., and Latham, D. R. (1978). Fuel Prepr. 23 (2), 58.
- Collins, C. J., Benjamin, B. M., Raaen, V. F., Maupin, P. H., and Roark, W. H. (1977a). Fuel Prepr. 22 (5), 98; also (1978). ACS Symp. Ser. 71 (Organic Chemistry of Coal), 165.
- Collins, C. J., Raaen, V. F., Benjamin, B. M., and Kobalka, G. W. (1977b). Fuel 56, 107.
- Collins, C. J., Raaen, V. F., Benjamin, B. M., Maupin, P. H., and Roark, W. H. (1979). J. Am. Chem. Soc. 101, 5009.
- Cottrell, T. L. (1958). "The Strengths of Chemical Bonds." Butterfields Scientific Publications, London, p. 274.
- Cronauer, D. C., Jewell, D. M., Shah, Y. T., and Modi, R. J. (1979). Ind. Eng. Chem. Fundam. 18, 153.
- Crynes, B. L. (1981a). In "Chemistry of Coal Utilization" (M. A. Elliott, ed.), 2d Suppl. Vol., John Wiley, New York, Chap. 29.
- Crynes, B. L. (1981b). Report DE-14876-8, U.S. Dept. of Energy.
- Crynes, B. L., and Albright, L. F. (1969). Ind Eng. Chem., Process Des. Dev. 8, 25.

- Cypres, R. (1981). Fuel Prepr. 26 (3), 44.
- Cypres, R., and Bettens, B. (1974). Tetrahedron 30, 1253.
- Cypres, R., and Bettens, B. (1975a). Tetrahedron 31, 353.
- Cypres, R., and Bettens, B. (1975b). Tetrahedron 31, 359.
- Cypres, R., and Lejeune, C. (1965). Ann. Mines Belg., 1091; C. A. 64, 625.
- Cypres, R., Braekman-Danheux, C., Bredael, P., and Einhorn, L. (1970). Ann. Mines Belg., 1105; C. A. 74, 89548.
- Davis, H. G., and Williamson, K. D. (1979). In "Thermal Hydrocarbon Chemistry" (A. G. Oblad, H. G. Davis, and R. T. Eddinger, eds.), Adv. Chem. Ser. 183, 41, Am. Chem. Soc., Washington, D.C.
- Dedinas, J., Henke, A. M., and Offutt, W. C. (1968). U.S. Patent 3,284,513, Nov. 8.
- Dente, M. E., and Ranzi, E. M. (1983). In "Pyrolysis: Theory and Industrial Practice" (L. F. Albright, B. L. Crynes, and O. Dermer, eds.), Chapter 7, Academic Press, New York.
- deRosset, A. J., Lau, G., and Gatsis, J. G. (1977). Petrol. Prepr. 22, 962; also (1979). Adv. Chem. Ser. 179 (Refining of Synthetic Crudes), 109.
- Ding, F. (1982), 'Phase Equilibria of Hydrogen-Coal Liquid and Hydrogen-Methane-Coal Liquid Systems', M.S. Thesis, University of Pittsburgh.
- Doue, F., and Guichon, G. (1968). J. Chim. Phys. 64, 395.
- Dunkleman, J. J., and Albright, L. F. (1976). In "Industrial and Laboratory Pyrolyses" (L. F. Albright and B. L. Crynes, eds.), ACS Symposium Ser., 32, Chapter 14, Am. Chem. Soc., Washington, D.C.
- Epperly, W. R. (1979). Report FE-2893-35; Energy Res. Abstr. 5, 12957.
- Fabuss, B. M., Smith, J. O., Lait, R. I., Borsanyi, A. S., and Satterfield, C. N. (1962). Ind. Eng. Chem., Process Des. Dev., 1, 293.
- Fabuss, B. M., Kafesjian, R., Smith, J. O., and Satterfield, C. N. (1964). Ind. Eng. Chem., Process Des. Dev., 3, 249.
- Farnum, S. A., and Knudson, C. L. (1978). Fuel Prepr. 23 (2), 67.
- Farnum, S. A., Olson, E. S., Farnum, B. W., and Wilson, W. C. (1980). Fuel Prepr. 25 (10), 245.
- Fleming, R. D., and Talbot, A. F. (1982). Petrol. Prepr. 27, 904.

- Friedel, R. A., Shultz, J. L., and Sharkey, A. G., Jr. (1966). Fuel Prepr. 10 (3), 120; also (1968) Fuel 47, 403.
- Friedman, S. (1981). Report DOE/PETC/QTR-81/1, Tech. Inform. Ctr., U. S. Dept. Energy, p. 38.
- Furimsky, E. (1979). AICHE J. 25, 306.
- Furimsky, E. (1982). Fuel Proc. Technol. 6, 1.
- Furimsky, E. (1983a). Ind. Eng. Chem., Prod. Res. Devel. 22, 31.
- Furimsky, E. (1983b). Ind. Eng. Chem., Prod. Res. Devel. 22, 34.
- Gates, B. C., and Petrakis, L. (1983). Abstracts and Research Accomplishments of AR & TD: Coal Liquefaction Projects, U.S. Dept. of Energy, p. 53.
- Givens, E. N., Collura, M. A., Skinner, R. W., and Greskovich, E. J. (1979). ACS Symp. Ser. 179 (Refining of Synthetic Crudes), 121.
- Goldfinger, P., Letort, M., and Niclause, M. (1948). "Contribution a l'etude de la Structure Moleculaire", Victor Henri Commemorative Volume, Desoer, Liege.
- Gomer, R., and Kistiakowsky, G. B. (1951). J. Chem. Phys., 19, 85.
- Gonikberg, M. G., and Li, G.-N. (1958). Dokl. Akad. Nauk SSSR 120, 1259; C. A. 53, 1210.
- Gonikberg, M. G., and Li, G.-N. (1960a). Dokl. Akad. Nauk SSSR 130, 763; C. A. 54, 9458.
- Gonikberg, M. G., and Li, G.-N. (1960b). Izv. Akad. Nauk SSSR, Otd. Khim. Nauk, 498; C. A. 54, 22439.
- Gonikberg, M. G., and Li, G.-N. (1961). Izv. Akad. Nauk SSSR, Otd. Khim. Nauk, 491; C. A. 55, 23398.
- Guenther, G. (1953). Freiberger Forsch. Bergakad. No. 17, 38; C. A. 48, 9651.
- Gutmann, V. (1978). "The Donor-Acceptor Approach to Molecular Interactions," Plenum Press, New York.
- Haider, G., Shabtai, J., and Oblad, A. C. (1981a). In Wiser, Report: Fossil Energy, DOE/ET/14700-3.
- Haider, G., Shabtai, J., and Oblad, A. C. (1981b). In Wiser, Report: Fossil Energy, DOE/ET/14700-5.
- Hall, C. C., and Cawley, C. M. (1939). J. Soc. Chem. Ind. 58, 7.

- Hausigk, D., Koelling, G., and Siegler, F. (1969). Brennstoff-Chem. 59, 8.
- Heck, R. H., and Stein, T. R. (1977). Petrol. Prepr. 22, 498.
- Hedaya, E., and Kent, M. E. (1971). J. Chem. Soc. 93, 3283.
- Hill, G. R., McClennen, W. H., Metcalf, G. S., Wang, H. H., and Meuzelaar, H. I. C. (1981). Proc. Int. Kohlenwiss. Tag., 477; C. A. 98, 56833.
- Huibers, D. T. A., and Gendler, J. L. (1981). "The Dynaphen Process: Phenol and Benzene via Thermal Hydrodealkylation of Coal Liquids", presented at AIChE Meeting, New Orleans, LA, Nov. 8-12.
- Hurd, C. D. (1929). "The Pyrolysis of Carbon Compounds", ACS Monograph No. 50, The Chemical Catalog Co., New York, p. 538.
- Hurtubise, R. J., Allen, T. W., Hussain, A., and Silver, H. F. (1981). Fuel Prepr. 26 (2), 55; also Hurtubise, R. J., Allen, T. W., Schabron, J. F., and Silver, H. F. (1981). Fuel 60, 385.
- Husack, R., and Golumbic, C. (1951). J. Am. Chem. Soc. 73, 1567.
- Ignasiak, B., Carson, D., Szladow, A. J., and Berkowitz, N. (1979). Fuel Prepr. 24 (2) 40; also (1980). ACS Symp. Ser. 139 (Coal Liquefaction Fundamentals), 97.
- Jacobs, H E., Jones, J. F., and Eddinger, R. T. (1970). Fuel Prepr. 14 (4), 42; also (1971) Ind. Eng. Chem., Proc. Des. Devel. 10, 558.
- Jelinek, J. F. (1963). Coll. Czech. Chem. Commun. 28, 504.
- Jones, B. W., and Neuworth, M. B. (1952). Ind. Eng. Chem. 44, 2872.
- Jones, B. W., and Neuworth, M. B. (1953). Ind. Eng. Chem. 45, 2704.
- Kamiya, Y., Sato, H., and Yao, T. (1978). Fuel 57, 681.
- Kamiya, Y., Yao, T., and Oikawa, S. (1979). Fuel Prepr. 24 (2), 116.
- Kamiya, Y., Nagai, S., and Oikawa, S. (1983). Fuel 62, 30.
- Kawa, W., and Hiteshue, R. W. (1963). U. S. Bur. Mines, Rept. Invest. No. 6179.
- Kawese, T., Arai, H., Tominaga, H., and Kunugi, T. (1970). Kogyo Kagaku Zasshi 73, 959; C. A. 74, 12437.
- Kelkar, B. G., Godbale, S. P., Devine, B., and Shah, Y. T. (1983). In "Investigation of Reactor Performance, Role of Inherent Catalysts, Hydrogen Donor Solvents and PCT Properties of Coal Liquids and Slurries", Final Report DOE/PC/50057-T4, I-1, Technical Information Center, U.S. Department of Energy.

- King, H. H., and Stock, L. M. (1982). Fuel 61, 1172.
- Klein, M. T., and Virk, P. S. (1983). Ind. Eng. Chem., Fundam. 22, 35.
- Kleinpeter, J. A., Jones, D. C., Dudd, P. J., and Burke, F. P. (1979). Ind. Eng. Chem., Process Des. Dev. 18, 535.
- Korai, Y., Fujitsu, H., Takeshita, K., and Mochida, I. (1981). Fuel 60, 1106.
- Kossiakoff, A., and Rice, F. O. (1943). J. Am. Chem. Soc. 65, 590.
- Krishnamurthy, S. (1980). 'The HDO of Dibenzofuran and Its Effect upon Heteroatom Removal', Ph.D. Thesis, Univ. Pittsburgh.
- Krishnamurthy, S., Shah, Y. T., and Stiegel, G. J. (1980). Fuel 59, 738.
- Krishnamurthy, S., Panvelkar, S., and Shah, Y. T. (1981). AIChE J. 27, 994.
- Laidler, K. J. (1965). "Chemical Kinetics", McGraw-Hill, New York.
- Laidler, K. J., and Loucks, L. F. (1972). In "Comprehensive Chemical Kinetics" (C. H. Bamford, and C. F. H. Tipper, eds.), Vol. 5, Chapter 1, Elsevier, Amsterdam.
- Landa, S., Mrnkova, A., and Bartova, N. (1969). Sci. Papers Inst. Chem. Technol., Prague, D16, 159; C. A. 74, 99747.
- Larsen, J. W., and Lee, D. (1983). Fuel 62, 463.
- Later, D. W., Lee, M. W., Bartle, K. D., Kong, R. C., and Vassilaros, D. L. (1981). Anal. Chem. 53, 1612.
- Liphard, K. G., Gade, M., Hendrick, K., Strobel, B., Riepe, W., and Koelling, G. (1981). Erdoel Kohle 34, 488.
- Maher, T. P., and O'Shea, J. M. (1967). Fuel 46, 283.
- Mallinson, R. G., Chao, K. C., and Greenhorn, R. A. (1980). Fuel Prepr. 25 (4), 120.
- Marsh, H., Foster, J. M., Hermon, G., Iley, M., and Melvin, J. N. (1973). Fuel 52, 243.
- Marzec, A., Juzwa, M., Betlej, K., and Sobkowiak, M. (1979). Fuel Process. Technol. 2, 35.
- Mayo, F. R. (1977). Fuel Prepr. 22 (5), 103.
- Mayo, F. R., and Kirshen, N. A. (1978). Fuel 57, 405.

- McMillen, D. F., Ogier, W. C., and Ross, D. S. (1981). Fuel Prepr. 26 (12), 181; also (1981). Proc.-Int. Kohlenwiss. Tag., 104; C. A. 98, 37373.
- Medepalli, K. S., and Kao, Y. K. (1981). Chem. Eng. Commun. 8, 269.
- Merz, V., and Weith, W. (1881). Ber. 14, 187.
- Messenger, L., and Attar, A. (1979). Fuel 58, 655.
- Mitchell, T. O. (1979). Proc. Electric Power Research Institute Contractors Conf. Coal Liquefaction, Palo Alto, CA, p. 2-2.
- Moldavskii, B. L., and Livshits, S. E. (1933). Z. Obshch. Khim. 3, 603; C. A. 28, 2693.
- Mortimer, J. (1980). Fuel 59, 782.
- Odebumni, E. O., and Ollis, D. F. (1983a). J. Catal. 80, 56.
- Odebumni, E. O., and Ollis, D. F. (1983b). J. Catal. 80, 65.
- Odebumni, E. O., and Ollis, D. F. (1983c). J. Catal. 80, 76.
- Ouchi, K., Katoh, K., and Itoh, H. (1981). Fuel, 60, 689.
- Panvelker, S. V., Shah, Y. T., and Cronauer, D. C. (1982). Ind. Eng. Chem., Fundam. 21, 236.
- Pauling, L. (1960). "The Nature of the Chemical Bond," 3rd ed., Cornell University Press, New York.
- Petrakis, L., Ruberto, R. G., Young, D. C., and Gates, B. C. (1983a). Ind. Eng. Chem., Process Des. Dev. 22, 292.
- Petrakis, L., Young, D. C., Ruberto, R. G., and Gates, B. C. (1983b). Ind. Eng. Chem., Process Des. Dev. 22, 298.
- Philip, C. V., and Anthony, R. G. (1977). Fuel Prepr. 22 (5), 31.
- Philip, C. V., and Anthony, R. G. (1978a). ACS Symp. Ser. 71 (Organic Chemistry of Coal), 258.
- Philip, C. V., and Anthony, R. G. (1978b). Fuel Prepr. 23 (4), 196; and (1982). Fuel 61, 351.
- Philip, C. V., and Anthony, R. G. (1982). Fuel 61, 357.
- Philip, C. V., Zingaro, R. A., and Anthony, R. G. (1980). Fuel Prepr. 25 (1), 47; also Philip, Anthony, and Zingaro (1981) ACS Symp. Ser. 156 (Upgrading Coal Liquids), 239.
- Pistrova, P. D., and Kharlampovich, G. D. (1974). Khim. Tverd. Topl. (1), 108; Solid Fuel Chem. 8, 94.

- Platonov, V. V., Ivleva, L. N., Klyavina, O. A., and Prokov'ev, E. E. (1981a). Khim. Tverd. Topl. (5), 84; Solid Fuel Chem. 15, 74.
- Platonov, V. V., Klyavina, O. A., Prokov'ev, E. E., and Ivleva, L. N. (1981b). Khim. Tverd Topl. (6), 96; Solid Fuel Chem. 15, 78.
- Platonov, V. V., Ivleva, L. N., Klyavina, O. A., and Prokov'ev, E. E. (1982). Khim Tverd Topl. (5), 89; Solid Fuel Chem. 16, 81.
- Platonov, V. V., Klyavina, O. A., Ivleva, L. N., and Prokov'ev, E. E. (1983). Khim. Tverd. Topl. (2), 138; C. A. 99, 21782.
- Polozov, V. F. (1935). Khim. Tverd Topl. 6, 78; C. A. 29, 7294.
- Poutsma, M. L. (1980). Petrol. Prepr. 25 (1), 30; also (1981). Proc.-Int. Kohlenwiss. Tag., 669; C. A. 98, 56836.
- Poutsma, M. L., and Dyer, C. W. (1981). Oak Ridge National Lab., TN, Contract W-7405-ENG-26.
- Poutsma, M. L., and Dyer C. W. (1982). J. Org. Chem. 47, 3367.
- Powers, D. R., and Corcoran, W. H. (1974). Ind Eng. Chem., Fundam. 13, 351.
- Pratt, G. L., and Rogers, D. (1979). J. Chem. Soc. Faraday, 175, 1089.
- Qader, S. A., Wiser, W. H., and Hill, G. R. (1968). Ind. Eng. Chem., Proc. Des. Dev. 7, 390.
- Raaen, V. F., and Roark, W. H. (1978). Fuel 57, 650.
- Rebick, C. (1983). In "Pyrolysis: Theory and Industrial Practice" (L. F. Albright, B. L. Crynes, and O. Dermer, eds.), Chapter 4, Academic Press, New York.
- Rice, F. O. (1931). J. Am. Chem. Soc. 53, 1959.
- Rice, F. O. (1933). J. Am. Chem. Soc. 55, 3035.
- Rice, F. O., and Herzfeld, K. F. (1934). J. Am. Chem. Soc. 56, 284.
- Richardson, W. H., and O'Neal, H. E. (1972). In "Comprehensive Chemical Kinetics" (C. H. Bamford, and C. F. H. Tipper, eds.), Vol. 5, Chapter 4, Elsevier, Amsterdam.
- Rieche, A., Redinger, L., and Lindenhayn, K. (1966). Brennstoff-Chem. 47, 326.
- Risinger, G. E., and Mach, E. B. (1962). Nature (London) 196, 1091.
- Roberti, G. (1931). Ann. Chim. Appl. 21, 217; C. A. 25, 5407.
- Roberti, G. (1932). Ann. Chim. Appl. 22, 3; C. A. 26, 2969.

- Rollman, L. D. (1977). J. Catal. 46, 243.
- Romey, I., Friedrich, F., and Strobel, B. (1981). Fuel Prepr. 26, 76.
- Ruberto, R. G., Cronauer, D. C., Jewell, P. M., and Seshadri, K. S. (1977). Fuel 56, 25.
- Sakai, T., and Hattori, M. (1976a). ACS Symp. Ser. 32, (Industrial and Laboratory Pyrolysis), p. 457.
- Sakai, T., and Hattori, M. (1976b). Chem. Lett. 1153.
- Sakai, T., and Yamane, N. (1983). Ind. Eng. Chem., Proc. Des. Dev. 22, 188.
- Sakai, T., Hattori, M., and Yamane, N. (1980a). Sekiyu Gakkaishi 23, 44; C. A. 93, 26153.
- Sakai, T., Hattori, M., and Yamane, N. (1980b). Sekiyu Gakkaishi 23, 334; C. A. 94, 138965.
- Sakai, T., Hattori, M., and Yamane, N. (1980c). Sekiyu Gakkaishi 23, 341; C. A. 94, 138966.
- Satterfield, D., Lanning, W. C., and Royer, R. E. (1980). Fuel Prepr. 25 (1), 79.
- Satterfield, C. N., and Yang, S. H. (1983). J. Catal. 81, 335.
- Schabron, J. F., Hurtubise, R. J., and Silver, H. F. (1979). Anal. Chem. 51, 1426.
- Scheppele, S. E., Benson, P. A., Greenwood, G. J., Grindstaff, Q. G., Aczel, T., and Beier, B. F. (1981). Adv. Chem. Ser. 195 (Chemistry of Asphaltenes), 53.
- Schiller, J. E. (1977). Hydrocarbon Process. 56 (1), 147.
- Schiller, J. E., and Mathiason, D. R. (1977). Anal. Chem. 49, 1225.
- Schiller, J. E., Farnum, B. W., and Sondreal, E. A. (1977). Fuel Prepr. 22 (6), 33.
- Schissler, D. O., and Stevenson, D. P. (1954). J. Chem. Phys. 22, 151.
- Schlosberg, R. H., Ashe, T. R., Pancirov, R. J., and Donaldson, M. (1981a). Fuel 60, 155.
- Schlosberg, R. H., Davis, W. H., Jr., and Ashe, T. R. (1981b). Fuel 60, 201.
- Schwager, I., and Yen, T. F. (1978). Fuel 57, 100.
- Schwager, I., and Yen, T. F. (1979). Fuel 58, 219.

- Schweighardt, F. K., White, C. M., Friedman, S., and Schultz, J. L. (1977). Fuel Prepr. 22 (5), 124; also (1975). ACS Symp. Ser. 71 (Organic Chemistry of Coal), 240.
- Seapan, M., and Crynes, B. L. (1981). Report U. S. DOE/BC/10306-11.
- Sebastian, H. M., Simnick, J. J., Lin, H. M., and Chao, K. C. (1980). J. Chem. Eng. Data 25, 68.
- Shabtai, J., and Shukla, Y. (1983). Abstracts and Research Accomplishments of AR & TD: Coal Liquefaction Projects, U.S. Dept. Energy, p. 4.
- Shabtai, J., Oblad, A. G., and Williams, J. (1983). Ibid., p. 5.
- Shih, S., Angevine, P. J., Heck, R. H., and Sawruk, S. (1980). Fuel Prepr. 25 (1), 152.
- Singerman, G. M. (1981) SAE Paper No. 810,443, in SAE SP-480.
- Siskin, M., and Aczel, T. (1983). Fuel 62, 1321.
- Smith, P. A. S., Romine, J. C., and Chou, S.-S. P. (1979). Petrol. Prepr. 24, 974; also S., R., C., and Schroder, R. P. (1981). Adv. Chem. Ser. 195 (Chemistry of Asphaltenes), 155.
- Snape, C. E., Smith, C. A., Bartle, K. D., and Mathews, R. S. (1982). Anal. Chem. 54, 20.
- Spielman, R., and Cramer, C. . (1972). Chromatographia 5, 295.
- Stein, T. R., Cabal, R. B., Callen, M. J., and Heck, R. H. (1978). Electric Power Research Institute Report, EPRI-AF-444.
- Storch, H. H., Fisher, C. H., Hawk, C. D., and Eisner, E. (1943). U. S. Bur. Mines, Tech. Paper 654.
- Sturm, C. P., Jr., Dooley, J. E., Thomson, J. S., Woodward, P. W., and Vogh, J. W. (1980). Fuel Prepr. 25 (1), 25.
- Szwarc, M. (1948). J. Chem. Phys. 16, 128.
- Takegami, Y., Kajiyama, S., and Yokoyama, C. (1963). Fuel 42, 291.
- Tewari, K. C., Hara, T., Li, N. C., and Fu, U. C. (1981). Fuel 60, 1137.
- Thomas, M. G., and Bickel, R. C. (1980). Fuel Prepr. 25, 95.
- Tilicheyev, M. D. (1939). Foreign Petroleum Tech. 7, 209.
- Tiwari, K. K., Kumar, P. R., and Bhaduri, T. J. (1978). Indian J. Technol. 16, 457.
- Tugrul, T., and Olcay, A. (1978). Fuel 57, 415.

- Vernon, L. W. (1980). Fuel 59, 102.
- Virk, P. S. (1979). Fuel 58, 149.
- Voge, H. H., and Good, G. M. (1949). J. Am. Chem. Soc. 71, 593.
- Wachowska, H., and Pawlak, M. (1977). Fuel 56, 216.
- Wailes, P. C. (1982). Fuel 61, 1038.
- Weigold, H. (1982). Fuel 61, 1021.
- Weinberg, V. L., and Yen, T. F. (1980). Fuel 59, 287.
- Weisser, O., and Landa, S. (1973). "Sulphide Catalysts, Their Properties and Applications", Pergamon Press, Elmsford, New York, p. 157.
- Wells, G. L., and Long, R. (1962). Ind. Eng. Chem., Process Des. Dev. 1, 73.
- White, C. M., and Li, N. C. (1982). Petrol. Prepr. 27, 890; also (1982). Anal. Chem. 54, 1570.
- White, C. M., and Schmidt, C. E. (1978). Fuel Prepr. 23 (2), 134.
- White, P. J., Jones, J. F., and Eddinger, R. T. (1968). Hydrocarbon Process. 47 (12), 97.
- Whitehurst, D. D., Mitchell, T. O., Farcasiu, M., and Dickert, J. J. (1979). Electric Power Research Institute Report AF-1298, Vol. 2, Project 410.
- Whitehurst, D. D., Mitchell, T. O., and Farcasiu, M. (1980). "Coal Liquefaction", Academic Press, New York.
- Wolfs, P. M. J., van Krevelen, D. W., and Waterman, H. I. (1959). Brennstoff-Chem. 40, 314.
- Yokoyama, S., Bodily, D. M., and Wiser, W. H. (1983). Fuel 62, 4.
- Yoshida, R., Hara, S., Yoshida, T., Yokoyama, S., Nakata, Y., Goto, Y., and Maekawa, Y. (1983). Liq. Fuels Technol. 1 (2), 101.
- Zaslonko, I. S., and Smirnov, V. N. (1979). Kinet. Katal 20, 575.
- Zhou, P., Dermer, O., and Crynes, B. L. (in press) 'Oxygen in Coals and Coal-Derived Liquids', In "Coal Science" (M.L. Gorbaty, ed.), Vol. 3, Academic Press, New York.
- Zingaro, R. A., Philip, C. V., Anthony, R. G., and Vindiola, A. (1981). Fuel Process. Technol. 4, 169.

APPENDIX A
EXPERIMENTAL PROCEDURE

A. System Purging and Cleaning

After the autoclave had been mounted and whole system assembled, the system was purged with N_2 or H_2 , depending upon what environment was desired for the reaction. The total volume of the system was estimated to be 0.003 m^3 and 0.3 m^3 of purge gas, at a rate of $0.6\text{ m}^3/\text{h}$, were used before each run was started. This guaranteed the complete removal of air previously in the system.

After the feedstock had been transferred from the storage tank to the feed tank, purge gas was led into the system through three lines, one leading into the feed tank and out through the overhead vent, the second conducting gas into the reactor through the injection line, and the third one leading into both the reactor and the sample tank. The purge gas then left the reactor through the gas sampling line, liquid sampling line and flash gas line to the vent, and also from the liquid sample release line.

After the reaction run had ended, the autoclave was cooled down and disassembled, residual reactants were removed and collected, the reactor was cleaned and the feed and sampling lines were flushed with acetone. The whole system was air-dried for at least 10 h and purged with N_2 for 0.5 h to make it ready for another run.

B. Feed Injection

A feed injection device was designed to facilitate rapid injection of the reactant into the reactor after the latter had attained a predetermined temperature. This produced a positive pressure difference between the feed tank, operating under designated system pressure, and

the reactor which was under a pressure 3.5 MPa lower than reaction pressure before injection.

In order to avoid thermal shock to the glass liner and too much temperature fluctuation during injection, special care was taken and an appropriate procedure followed. In experimental runs with OEP in solvent as feedstock, $4 \times 10^{-4} \text{ m}^3$ of dodecane was loaded into the reactor, OEP and the balance of the solvent was placed in the feed tank and heated to 573 K, and the hot solution was injected. The reactor temperature had previously been brought up to 10-20 K higher than the required reaction temperature and feed in the tank was instantly transferred to the reactor by the pressure difference mentioned above. Runs with p- and m-ethylphenol in dodecane as feed were handled in the same way. In pure OEP runs 1/5 of the feed was pre-loaded to the reactor and the rest injected, while in the case of pure solvent feed, all the dodecane was loaded in the reactor.

The injection, then the mixing of the two parts of the feed, caused the reactor temperature to drop by 20-30 K. In most of the runs a temperature fluctuation within $\pm 3 \text{ K}$ occurred. However, the reactor attained the operating temperature within a few minutes, whence it could be maintained to within 1 K of the set point. Upon injection, the reactor pressure was simultaneously raised to the required reaction pressure. A stopwatch was immediately started and zero reaction time recorded.

This rapid-injection technique allowed the precise definition of zero reaction time and avoided complications caused by long heat-up periods.

In order to minimize thermal reactions in the feed tank, the preheat temperature was not allowed to exceed 573 K. At temperatures lower than 573 K and for a period of less than 0.5 h, thermal reactions of either the solvent or the substrate were negligible, as can be seen from the data in Appendix B.

The time required to bring the reactor temperature from ambient to designated value was about 0.3 to 0.5 h. For a reaction temperature of 623 K, the reaction occurring in the feed inside the reactor before injection was not significant. When the desired reaction temperature was higher, say 673 K, the pre-loaded solvent might undergo significant conversion that needed to be taken into account. As soon as the injection was completed, a liquid sample was collected to determine the initial concentration of the reactant so that it could be used while performing the kinetic calculation.

C. Product Sampling

Depending on the total reaction time, 10-24 gas and liquid samples were taken for each reaction run.

As already mentioned, the gas sample was allowed to flow along the gas sampling line and pass through a trap which was at ambient temperature. Heavy components were condensed and condensate was released from the trap and collected. No liquid carryover was observed. The gas then flowed through a wet-test meter and samples were stored in gas sampling bags.

Due to the intentionally low conversion in the reaction runs, the system pressure remained essentially unchanged; it did decrease somewhat

(about 0.3 MPa) while sampling, but was immediately brought back by make-up gas provided by the Mity-Mite control valve.

Taking the liquid sample was somewhat complicated because of the hold-up in the liquid sampling line. By design the liquid sampling line was made as short as possible (about 0.15 m of 0.0032 m O.D. tubing). Prior to sampling, the pressure in the sample tank was made 0.3 MPa higher than that of the reactor and the liquid pre-existing in the line was forced back to the reactor. Then the sample tank pressure was immediately brought back to 0.3 MPa lower than reactor pressure, enabling the collection of authentic samples from the reactor.

The liquid in the sample tank was flashed by two-stage pressure reduction as described earlier. The flash gas passed through another trap which was also at ambient temperature and condensate flowed back to the sample tank. Liquid samples and flash gas samples were collected separately and the former stored in a freezer until analysis.

D. Reaction Quenching

As soon as the scheduled run length was achieved, water was fed into the cooling coil inside the autoclave and the reaction temperature was quickly reduced to below 573 K in about 0.08 h. The temperature was continuously reduced to ambient temperature before the system was disassembled for cleaning.

E. Product Analysis

Analyses of both gas and liquid samples were performed on an Hewlett Packard 5880A series gas chromatograph equipped with a level-four terminal and an electronic integrator.

The following columns were used:

(A) a 2 m 0.0032 m O.D. stainless steel column packed with Carbowax 20 M on Chromosorb W H/P, mesh 80/100;

(B) a similar column prepacked (Varian) with 1% SP-1240 DA on Supelcoport, mesh 100/200. This is an EPA-suggested column for separating phenols and acidic components; and

(C) a 4 m 0.0032 m O.D. stainless steel column packed with Porapak Q, mesh 100/120 (Analabs).

With a flame ionization detector (FID), column B was used for routine liquid sample analysis. Column A was used frequently to verify the results obtained with column B. Selected samples were analyzed by using combined GC/MS (Water Quality Research Laboratory, Oklahoma State University) to identify some unknowns and to check GC results.

The temperature program employed for column B was: initial column temperature 313 K, initial time 0.017 h, program rate 0.17 K/s, final temperature 452 K, final time 0.17 H. The injector and detector were held at 523 K.

Gas samples were analyzed using column C isothermally at 433 K with an FID. In a few analyses a thermal conductivity detector was used in order to detect carbon monoxide.

For the FID, the carrier gas (N_2) flow rate was 0.0018 m^3/h ; hydrogen and air flow rates were 0.0019 and 0.024 m^3/h , respectively.

Analytical standard kits (PolyScience Corporation) No. 91C (for hydrocarbons) and No. 170C (for phenols) and calibrating gases from Varian Company and Scott Environmental Technology, Inc. (for gas components) were utilized to determine relative retention times (RRT)

and relative response factors of related compounds, with the latter defined as:

Relative Weight Response Factor of Component i (RWRF)

$$= \frac{\text{wt.\% of Component } i / \text{Peak Area of Component } i}{\text{wt.\% of Reference Compound} / \text{Peak Area of Ref. Comp.}}$$

Relative Molar Response of Component i (RMRF)

$$= \frac{\text{mol\% of Component } i / \text{Peak Area of Component } i}{\text{mol\% of Reference Compound} / \text{Peak Area of Ref. Comp.}}$$

In use, the peak areas are divided by the appropriate RWRF and RMRF as:

$$\text{Wt.\% of Component } i \text{ (in a mixture)} = \frac{\text{Peak Area of } i / \text{RWRF of } i}{\sum (\text{Area} / \text{RWRF})}$$

$$\text{Mol\% of Component } i \text{ (in a mixture)} = \frac{\text{Peak Area of } i / \text{RMRF of } i}{\sum (\text{Area} / \text{RMRF})}$$

The relative response factors of relevant compounds are listed in Tables XV to XVIII.

In gas analysis, ethane was used as a reference compound. For liquid samples from pure dodecane runs, dodecane was used as reference. In ethylphenol runs, the corresponding ethylphenol was taken as the reference compound. For the purpose of simplifying calculations, graphs of concentration versus peak area under certain conditions for different reference compounds were constructed on the basis of calibration data (Figures 49 to 52). All these graphs show linearity of detector response for these compounds.

The columns tested for reproducibility of results by periodically injecting standard calibration mixtures and analyzing the output from the chromatograph. Results indicated that no observable deterioration of the column packings occurred during the course of the present study.

TABLE XV
RELATIVE MOLAR RESPONSE FACTORS OF LIGHT HYDROCARBONS
(FID, REFERENCE: ETHANE)

| Compound | Relative molar response factor |
|-----------|--------------------------------|
| Methane | 1.91 |
| Ethylene | 0.57 |
| Ethane | 1.00 |
| Propylene | 0.87 |
| Propane | 0.69* |
| 1-Butene | 0.75 |
| Butane | 0.55* |
| 1-Pentene | 0.74 |
| Pentane | 0.54* |

* Estimated from: Dietz, W. A., J. Gas Chromatogr., 5, 68 (1967)

TABLE XVI
 RELATIVE WEIGHT RESPONSE FACTORS OF HYDROCARBONS
 (FID, REFERENCE: DODECANE)

| Compound | RWRF | Compound | RWRF |
|------------------------|------|---------------|------|
| Pentane | 1.09 | 1-Pentene | 1.08 |
| 2-Methylpentane | 1.12 | 1-Hexene | 1.07 |
| Hexane | 1.07 | 1-Heptene | 1.07 |
| Heptane | 1.05 | 1-Octene | 1.09 |
| 2,2,4-Trimethylpentane | 1.09 | 1-Nonene | 0.97 |
| Dimethylhexane* | 1.13 | 1-Decene | 1.04 |
| Octane | 1.04 | 1-Undecene | 1.02 |
| 2,2,5,-Trimethylhexane | 1.12 | 1-Dodecene | 1.04 |
| Nonane | 1.03 | 1-Tridecene | 0.99 |
| Decane | 1.02 | 1-Tetradecene | 1.00 |
| Undecane | 1.01 | 1-Pentadecene | 1.01 |
| Dodecane | 1.00 | 1-Hexadecene | 1.02 |
| Tridecane | 1.00 | | |
| Tetradecane | 0.99 | Benzene | 0.89 |
| Hexadecane | 1.00 | Toluene | 0.91 |
| Octadecane | 0.99 | m-Xylene | 0.67 |
| Nonadecane | 0.99 | o-Xylene | 0.63 |
| Heneidecane | 0.99 | p-Xylene | 0.67 |
| Docosane | 0.98 | Ethylbenzene | 0.86 |

* as specified by vendor.

TABLE XVII
RELATIVE WEIGHT RESPONSE FACTORS OF OXYGEN COMPOUNDS
(FID, REFERENCE: OEP)

| Compound | RWRF |
|---------------|-------|
| Phenol | 0.997 |
| o-Cresol | 0.959 |
| p-Cresol | 0.981 |
| m-Cresol | 1.01 |
| o-Ethylphenol | 1.00 |
| p-Ethylphenol | 0.975 |
| m-Ethylphenol | 0.987 |
| 2,6-Xylenol | 1.04 |
| 2,5-Xylenol | 1.05 |
| 2,4-Xylenol | 1.07 |
| 3,5-Xylenol | 1.10 |
| 3,4-Xylenol | 1.09 |

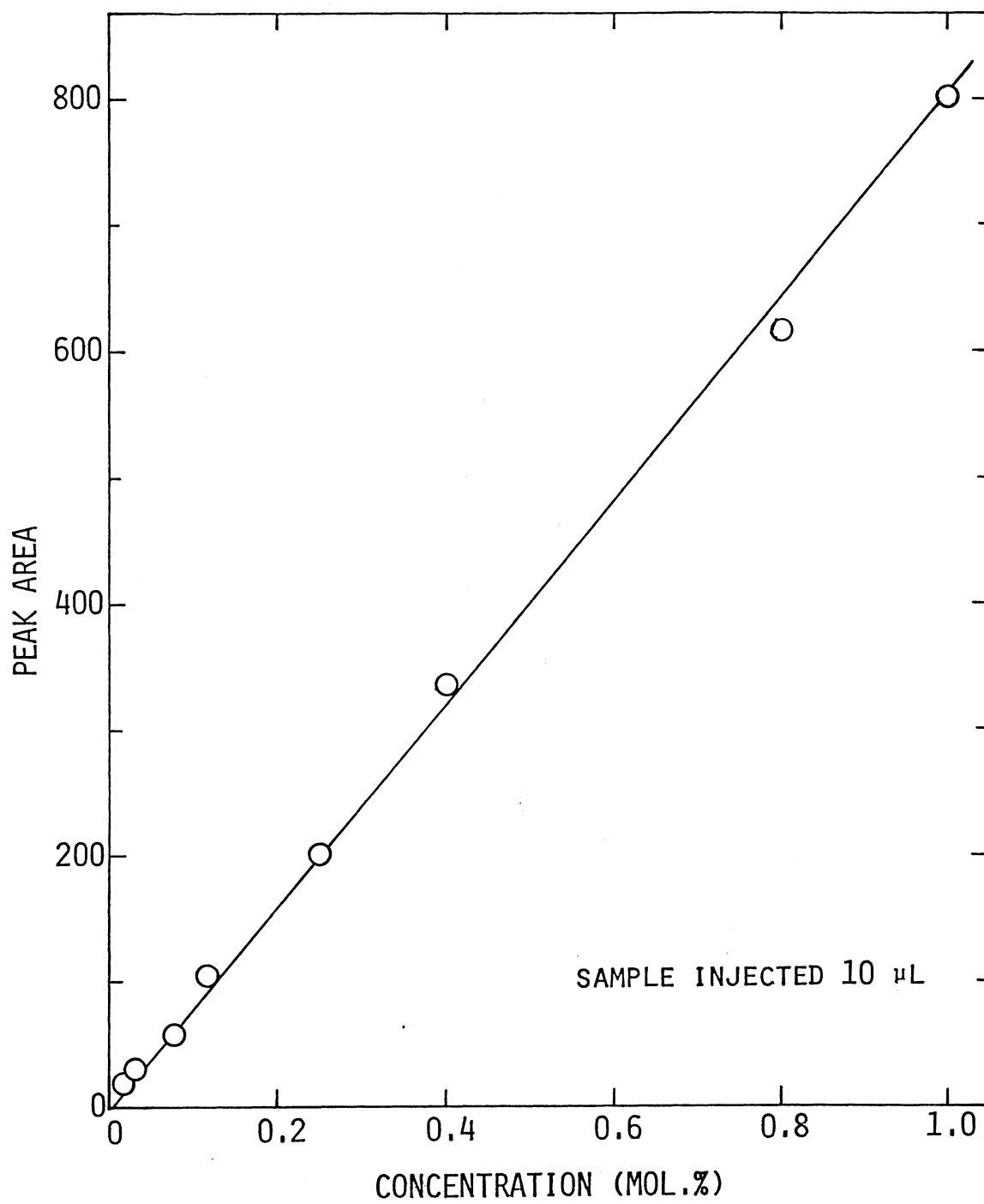

Figure 49. Detector Response for Ethane

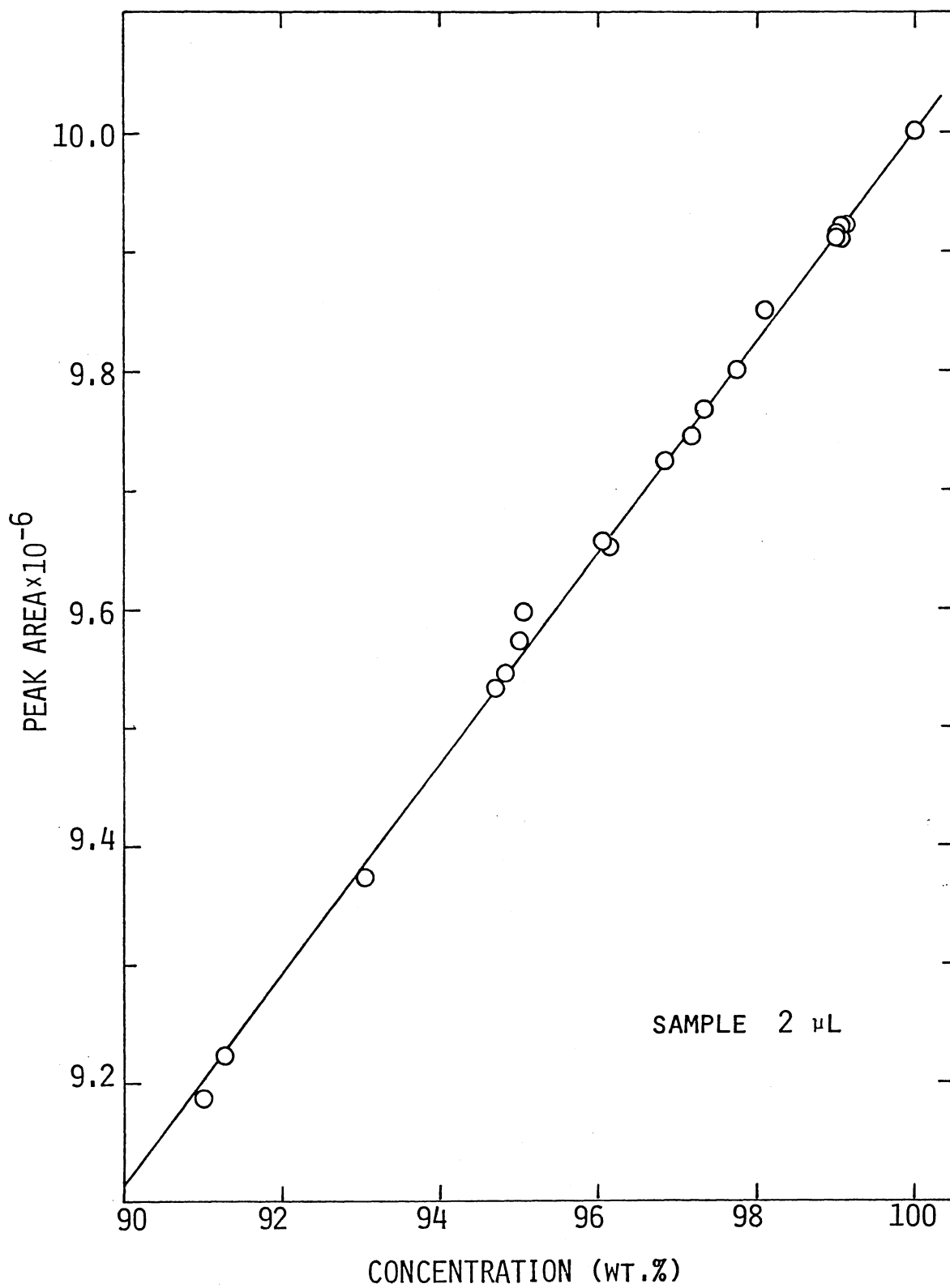

Figure 50. Detector Response for Dodecane

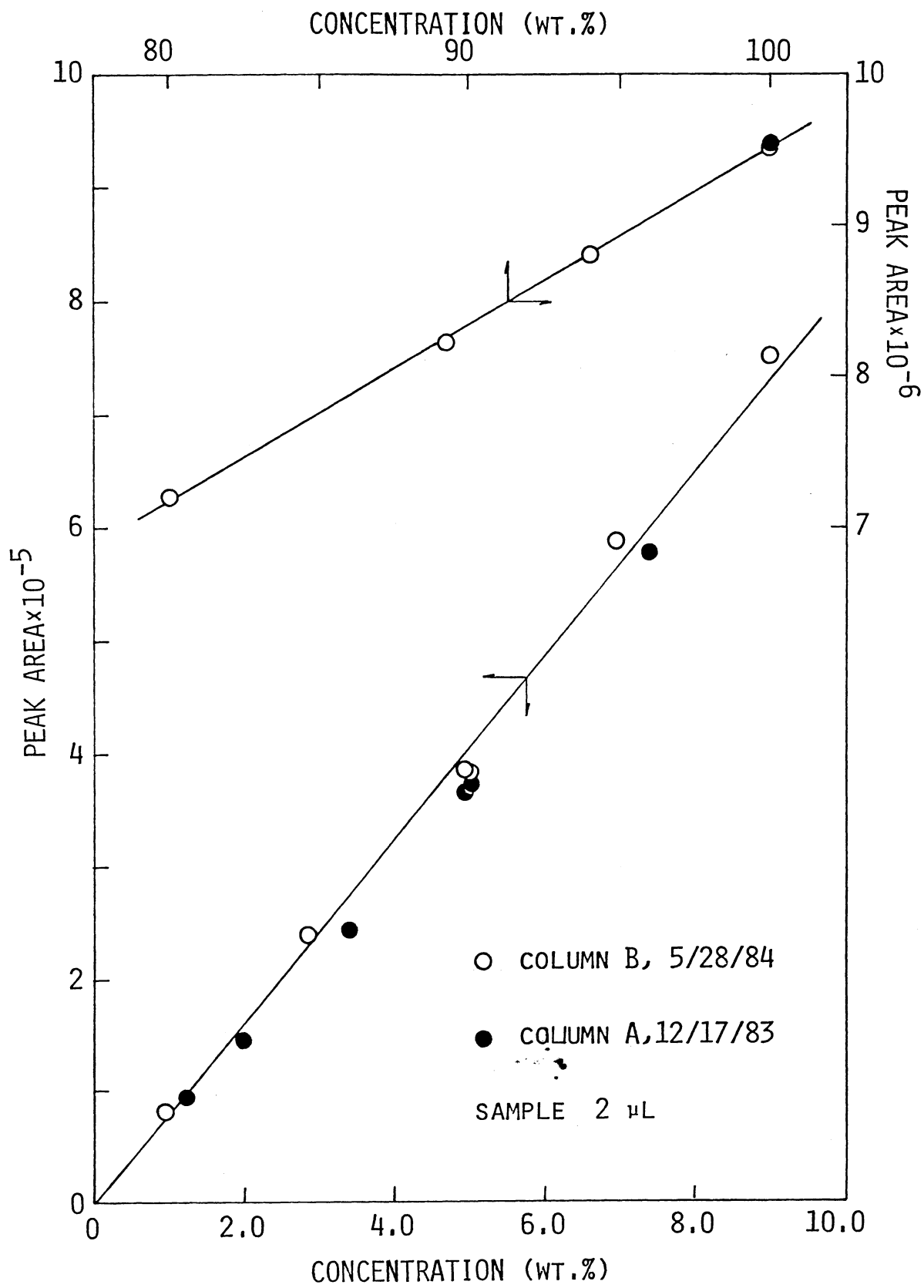

Figure 51. Detector Response for o-Ethylphenol

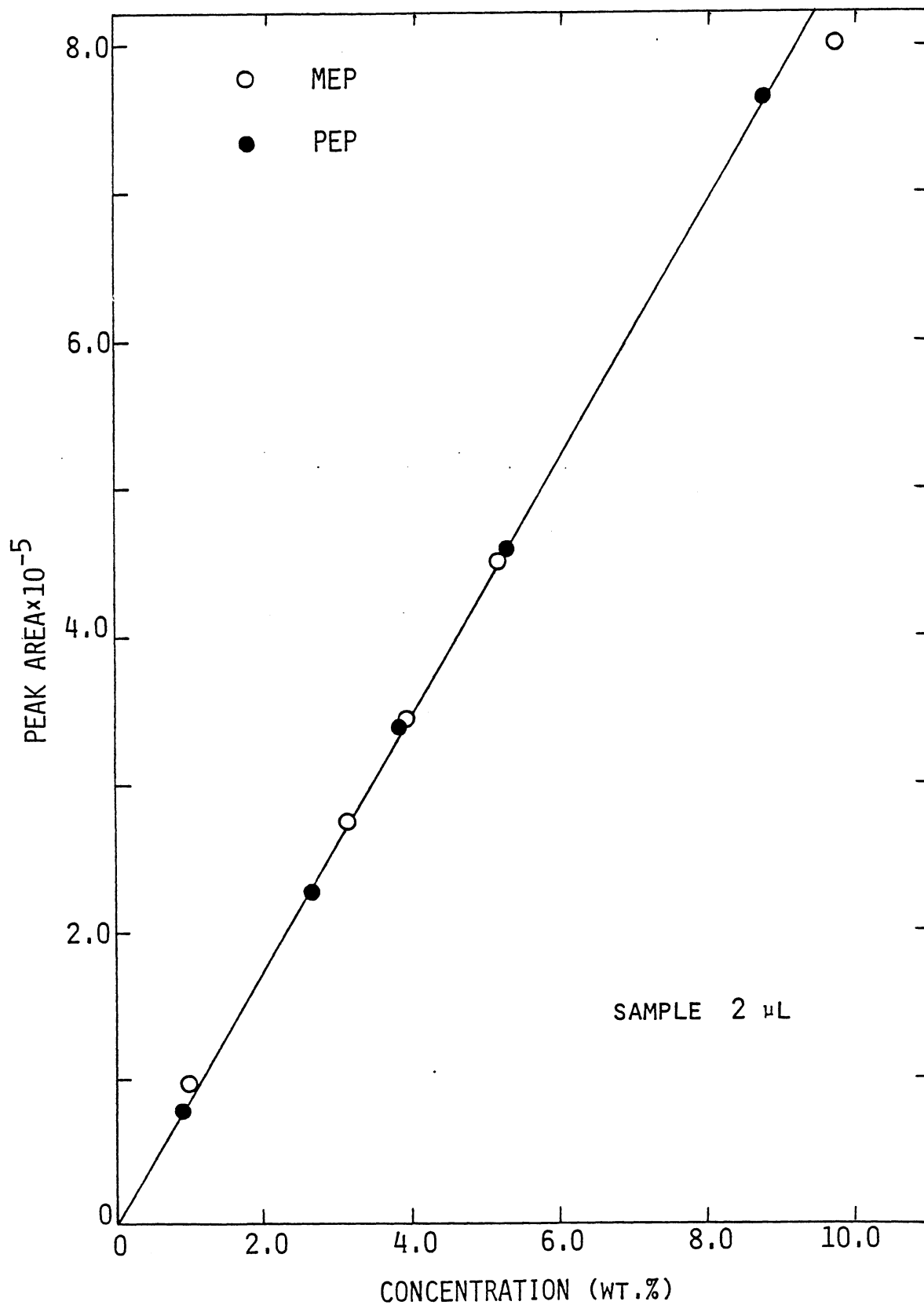

Figure 52. Detector Response for p- and m-Ethylphenols

APPENDIX B
TABULATION OF EXPERIMENTAL DATA

TABLE XVIII
MATERIAL BALANCES OF REACTION RUNS

| Run no. | Feed (wt.%) | Liquid recovered (wt.%) | Gas* + Loss (wt.%) |
|---------|----------------|----------------------------|-----------------------|
| 12 | 100 | 98.55 | 1.45 |
| 13 | 100 | 96.21 | 3.79 |
| 14 | 100 | 95.33 | 4.67 |
| 15 | 100 | 99.00 | 1.00 |
| 16 | 100 | 96.19 | 3.81 |
| 17 | 100 | 94.92 | 5.08 |
| 18 | 100 | 96.26 | 3.74 |
| 19 | 100 | 94.45 | 5.55 |
| 20 | 100 | 96.61 | 3.39 |
| 21 | 100 | 96.84 | 3.16 |
| | | | average 3.56 |

* The gas produced is mixed with a large amount of N₂ or H₂, the gas make is estimated to be from about than 0.1 wt.% for low-conversion runs up to 3.5 wt.% for high-conversion runs.

TABLE XIX
THERMAL REACTIVITY OF DODECANE
(RUN 2, 10.3 MPa, N₂)

| Reaction time (10 ³ s) | Temperature (K) | n-C ₁₂ Concentration (wt.%) | Conversion (%) |
|--------------------------------------|--------------------|---|-------------------|
| 0 | 523 | 99.39 | 0 |
| 1.2 | 591 | 99.33 | 0.056 |
| 2.4 | 604 | 99.23 | 0.16 |
| 3.6 | 616 | 99.14 | 0.25 |
| 4.8 | 625 | 99.14 | 0.26 |
| 6.0 | 635 | 99.10 | 0.29 |
| 7.2 | 645 | 99.10 | 0.29 |
| 8.4 | 655 | 98.98 | 0.41 |
| 9.6 | 658 | 98.74 | 0.66 |
| 10.8 | 669 | 97.95 | 1.5 |
| 12.0 | 673 | 97.49 | 1.9 |
| 13.2 | 683 | 96.19 | 3.2 |

TABLE XX
THERMAL REACTIVITY OF DODECANE
(RUN 1, 10.3 MPa, N₂)

| Reaction time (10 ³ s) | Temperature (K) | n-C ₁₂ Concentration (mol%) | Conversion (%) |
|--------------------------------------|--------------------|---|-------------------|
| 0 | 673 | 99.73 | 0 |
| 1.2 | 685 | 87.71 | 12.1 |
| 2.4 | 686 | 79.86 | 19.9 |
| 3.6 | 685 | 73.97 | 25.8 |
| 4.8 | 713 | 66.75 | 33.1 |
| 6.0 | 713 | 60.78 | 39.1 |
| 7.2 | 713 | 53.94 | 45.9 |
| 8.4 | 663 | 52.68 | 47.2 |
| 9.6 | 662 | 51.15 | 48.7 |
| 10.8 | 659 | 50.83 | 49.0 |
| 12.0 | 658 | 50.01 | 49.9 |

TABLE XXI
THERMAL REACTIVITY OF DODECANE
(RUN 7, 623 K, 9.2 MPa, N₂)

| Reaction time (10 ³ s) | n-C ₁₂ Concentration (mol%) | Conversion (%) |
|--------------------------------------|---|-------------------|
| 0 | 99.79 | 0 |
| 0.6 | 99.67 | 0.12 |
| 1.8 | 99.60 | 0.19 |
| 3.6 | 99.48 | 0.31 |
| 4.8 | 99.38 | 0.41 |
| 7.8 | 99.25 | 0.54 |
| 9.6 | 99.14 | 0.65 |
| 13.2 | 98.94 | 0.85 |
| 16.8 | 98.88 | 0.91 |
| 20.4 | 98.71 | 1.08 |
| 24.0 | 98.57 | 1.22 |
| 27.0 | 98.48 | 1.31 |
| 30.6 | 98.36 | 1.43 |

TABLE XXII
 PRODUCT DISTRIBUTION OF DODECANE THERMOLYSIS (MOL%)
 (RUN 12, 623 K, 9.2 MPa, N₂)

| Reaction Time (10 ³ s) | < C ₅ | C ₆ | C ₆ ⁼ | C ₇ | C ₇ ⁼ | C ₈ | C ₈ ⁼ | C ₉ | C ₉ ⁼ | C ₁₀ | C ₁₀ ⁼ | C ₁₁ + C ₁₁ ⁼ | C ₁₂ | > C ₁₂ |
|--------------------------------------|------------------|----------------|-----------------------------|----------------|-----------------------------|----------------|-----------------------------|----------------|-----------------------------|-----------------|------------------------------|--|-----------------|-------------------|
| 0 | 0.013 | 0.013 | 0.031 | 0.014 | 0.012 | 0.015 | 0.030 | 0.008 | 0.016 | 0.003 | 0.005 | 0.092 | 99.74 | 0.007 |
| 0.9 | 0.023 | 0.021 | 0.058 | 0.018 | 0.026 | 0.022 | 0.046 | 0.013 | 0.026 | 0.005 | 0.016 | 0.092 | 99.63 | 0.008 |
| 1.9 | 0.078 | 0.042 | 0.056 | 0.020 | 0.032 | 0.022 | 0.051 | 0.014 | 0.029 | 0.005 | 0.016 | 0.092 | 99.54 | 0.008 |
| 3.6 | 0.088 | 0.049 | 0.071 | 0.021 | 0.041 | 0.022 | 0.050 | 0.020 | 0.026 | 0.007 | 0.019 | 0.093 | 99.49 | 0.009 |
| 5.4 | 0.097 | 0.057 | 0.102 | 0.034 | 0.059 | 0.031 | 0.063 | 0.025 | 0.036 | 0.009 | 0.023 | 0.090 | 99.34 | 0.032 |
| 7.2 | 0.136 | 0.077 | 0.112 | 0.043 | 0.068 | 0.043 | 0.073 | 0.029 | 0.041 | 0.016 | 0.025 | 0.097 | 99.21 | 0.031 |
| 9.0 | 0.156 | 0.078 | 0.121 | 0.045 | 0.057 | 0.036 | 0.074 | 0.029 | 0.044 | 0.010 | 0.021 | 0.096 | 99.13 | 0.103 |
| 10.8 | 0.175 | 0.084 | 0.132 | 0.046 | 0.078 | 0.046 | 0.087 | 0.030 | 0.057 | 0.011 | 0.026 | 0.093 | 99.01 | 0.122 |
| 12.6 | 0.191 | 0.099 | 0.145 | 0.053 | 0.083 | 0.053 | 0.089 | 0.029 | 0.061 | 0.011 | 0.021 | 0.093 | 98.94 | 0.133 |
| 14.4 | 0.204 | 0.105 | 0.140 | 0.052 | 0.081 | 0.051 | 0.089 | 0.030 | 0.064 | 0.011 | 0.021 | 0.091 | 98.92 | 0.145 |
| 16.2 | 0.217 | 0.114 | 0.164 | 0.060 | 0.094 | 0.059 | 0.097 | 0.029 | 0.070 | 0.010 | 0.024 | 0.093 | 98.82 | 0.154 |
| 18.0 | 0.233 | 0.122 | 0.177 | 0.066 | 0.104 | 0.066 | 0.109 | 0.033 | 0.076 | 0.012 | 0.033 | 0.099 | 98.71 | 0.165 |
| 21.0 | 0.240 | 0.126 | 0.183 | 0.069 | 0.113 | 0.073 | 0.119 | 0.047 | 0.086 | 0.012 | 0.029 | 0.101 | 98.62 | 0.179 |
| 24.0 | 0.259 | 0.128 | 0.194 | 0.080 | 0.113 | 0.082 | 0.142 | 0.061 | 0.091 | 0.021 | 0.048 | 0.123 | 98.47 | 0.192 |

TABLE XXIII
 PRODUCT DISTRIBUTION OF DODECANE THERMOLYSIS (MOL%)
 (RUN 13, 673 K, 9.2 MPa, N₂)

| Reaction Time (10 ³ s) | < C ₅ | C ₆ | C ₆ ⁼ | C ₇ | C ₇ ⁼ | C ₈ ⁼ | C ₈ | C ₉ | C ₉ ⁼ | C ₁₀ | C ₁₀ ⁼ | C ₁₁ | C ₁₁ ⁼ | C ₁₂ | > C ₁₂ |
|--------------------------------------|------------------|----------------|-----------------------------|----------------|-----------------------------|-----------------------------|----------------|----------------|-----------------------------|-----------------|------------------------------|-----------------|------------------------------|-----------------|-------------------|
| 0 | 0.055 | 0.053 | 0.104 | 0.032 | 0.061 | 0.033 | 0.074 | 0.004 | 0.082 | 0.011 | 0.023 | 0.080 | - | 99.33 | 0.083 |
| 1.32 | 0.677 | 0.405 | 0.530 | 0.183 | 0.319 | 0.187 | 0.302 | 0.023 | 0.256 | 0.016 | 0.067 | 0.083 | - | 96.68 | 0.282 |
| 3.0 | 1.48 | 0.673 | 0.852 | 0.291 | 0.480 | 0.297 | 0.433 | 0.065 | 0.358 | 0.024 | 0.099 | 0.087 | 0.026 | 94.41 | 0.435 |
| 5.4 | 1.74 | 0.991 | 1.22 | 0.470 | 0.686 | 0.470 | 0.605 | 0.082 | 0.471 | 0.033 | 0.101 | 0.089 | 0.019 | 92.42 | 0.609 |
| 7.2 | 2.31 | 1.32 | 0.66 | 0.721 | 0.881 | 0.701 | 0.779 | 0.185 | 0.669 | 0.042 | 0.237 | 0.097 | 0.023 | 88.81 | 1.51 |
| 9.0 | 3.13 | 1.79 | 2.97 | 1.12 | 1.22 | 1.04 | 1.15 | 0.318 | 1.02 | 0.113 | 0.342 | 0.131 | 0.030 | 82.88 | 2.73 |
| 12.0 | 3.91 | 2.23 | 2.98 | 3.01 | | 1.41 | 1.20 | 0.469 | 1.03 | 0.152 | 0.541 | 0.137 | 0.040 | 78.79 | 4.10 |
| 15.0 | 6.61 | 3.12 | 3.65 | 3.61 | | 1.79 | 1.23 | 0.685 | 1.08 | 0.204 | 0.624 | 0.149 | 0.049 | 71.82 | 5.37 |
| 18.0 | 8.86 | 3.90 | 4.49 | 4.48 | | 2.27 | 1.32 | 0.983 | 1.20 | 0.295 | 0.839 | 0.189 | 0.076 | 64.36 | 6.74 |

TABLE XXIV
 PRODUCT DISTRIBUTION OF DODECANE THERMOLYSIS (MOL%)
 (RUN 14, 623 K, 9.2 MPa, H₂)

| Reaction Time (10 ³ s) | < C ₅ | C ₆ | C ₆ [≡] | C ₇ | C ₇ [≡] | C ₈ | C ₈ [≡] | C ₉ | C ₉ [≡] | C ₁₀ | C ₁₀ [≡] | C ₁₁ ⁺ C ₁₁ [≡] | C ₁₂ | > C ₁₂ |
|--------------------------------------|------------------|----------------|-----------------------------|----------------|-----------------------------|----------------|-----------------------------|----------------|-----------------------------|-----------------|------------------------------|---|-----------------|-------------------|
| 0 | 0.007 | 0.006 | 0.022 | - | - | 0.006 | 0.018 | 0.004 | 0.007 | 0.004 | 0.006 | 0.093 | 99.82 | 0.007 |
| 0.9 | 0.010 | 0.009 | 0.026 | - | - | 0.006 | 0.020 | 0.007 | 0.011 | 0.004 | 0.008 | 0.090 | 99.81 | 0.007 |
| 2.76 | 0.026 | 0.025 | 0.043 | - | 0.035 | 0.023 | 0.025 | 0.009 | 0.019 | 0.004 | 0.009 | 0.095 | 99.68 | 0.008 |
| 4.8 | 0.055 | 0.042 | 0.076 | - | 0.041 | 0.031 | 0.046 | 0.012 | 0.033 | 0.003 | 0.010 | 0.093 | 99.55 | 0.008 |
| 7.2 | 0.065 | 0.053 | 0.093 | 0.027 | 0.050 | 0.043 | 0.063 | 0.014 | 0.048 | 0.004 | 0.014 | 0.096 | 99.42 | 0.009 |
| 9.6 | 0.071 | 0.059 | 0.093 | 0.039 | 0.069 | 0.046 | 0.069 | 0.018 | 0.053 | 0.006 | 0.013 | 0.091 | 99.35 | 0.018 |
| 12.0 | 0.075 | 0.061 | 0.104 | 0.048 | 0.078 | 0.057 | 0.076 | 0.033 | 0.057 | 0.009 | 0.023 | 0.102 | 99.24 | 0.036 |
| 14.4 | 0.075 | 0.061 | 0.117 | 0.048 | 0.083 | 0.057 | 0.086 | 0.038 | 0.057 | 0.011 | 0.024 | 0.103 | 99.16 | 0.077 |
| 16.8 | 0.075 | 0.061 | 0.121 | 0.050 | 0.087 | 0.057 | 0.088 | 0.048 | 0.056 | 0.012 | 0.026 | 0.092 | 99.13 | 0.094 |
| 19.2 | 0.078 | 0.070 | 0.117 | 0.057 | 0.100 | 0.055 | 0.096 | 0.055 | 0.059 | 0.016 | 0.032 | 0.093 | 99.07 | 0.105 |
| 21.6 | 0.097 | 0.080 | 0.125 | 0.055 | 0.100 | 0.059 | 0.096 | 0.052 | 0.057 | 0.015 | 0.034 | 0.091 | 99.03 | 0.109 |
| 24.0 | 0.146 | 0.093 | 0.147 | 0.064 | 0.100 | 0.070 | 0.097 | 0.057 | 0.067 | 0.017 | 0.038 | 0.098 | 98.87 | 0.135 |

TABLE XXV
GAS ANALYSIS OF DODECANE THERMOLYSIS (MOL%)

| Reaction Time (10 ³ s) | C ₁ | C ₂ ⁼ | C ₂ | C ₃ ⁼ | C ₃ | C ₄ ⁼ | C ₄ | (C ₂ +C ₂ ⁼)/C ₁ | C ₂ ⁼ /C ₂ |
|--|----------------|-----------------------------|----------------|-----------------------------|----------------|-----------------------------|----------------|---|---|
| Run 12 (623 K, 9.2 MPa, N ₂) | | | | | | | | | |
| 3.6 | 0.004 | trace | 0.017 | 0.014 | 0.017 | trace | trace | 4.3 | - |
| 10.8 | 0.018 | 0.003 | 0.067 | 0.053 | 0.071 | 0.029 | 0.050 | 3.9 | 0.04 |
| Run 13 (673 K, 9.2 MPa, N ₂) | | | | | | | | | |
| 0 | 0.029 | 0.011 | 0.104 | 0.061 | 0.098 | - | - | 4.0 | 0.11 |
| 3.0 | 0.053 | 0.023 | 0.229 | 0.183 | 0.261 | 0.084 | 0.106 | 4.8 | 0.10 |
| 7.2 | 0.156 | 0.041 | 0.535 | 0.288 | 0.476 | 0.106 | 0.148 | 3.7 | 0.08 |
| 12.0 | 0.205 | 0.043 | 0.666 | 0.319 | 0.557 | 0.101 | 0.158 | 3.5 | 0.06 |
| 18.0 | 0.809 | 0.077 | 2.39 | 0.777 | 2.22 | 0.274 | 0.863 | 3.1 | 0.03 |
| Run 14 (623 K, 9.2 MPa, H ₂) | | | | | | | | | |
| 0.9 | 0.005 | trace | 0.017 | - | 0.046 | - | trace | 3.4 | ~ 0 |
| 4.8 | 0.004 | trace | 0.023 | - | 0.073 | - | trace | 5.8 | ~ 0 |
| 9.6 | trace | trace | 0.032 | - | 0.149 | - | trace | - | ~ 0 |
| 14.4 | 0.009 | 0.002 | 0.042 | - | 0.154 | - | trace | 4.9 | 0.05 |
| 24.4 | trace | trace | 0.032 | - | 0.169 | - | trace | - | ~ 0 |

TABLE XXVI
 PRODUCT DISTRIBUTION OF o-ETHYLPHENOL THERMOLYSIS (MOL%)
 (RUN 15, 623 K, 9.2 MPA, N₂)

| Reaction time (10 ³ s) | Benzene | Toluene | Ethyl- benzene | Phenol | o-Cresol | o-Ethyl- phenol | p-,m- Cresols | p-Ethyl- phenol | m-Ethyl- phenol | Xylenols | Heavies |
|--------------------------------------|---------|---------|-------------------|--------|----------|--------------------|------------------|--------------------|--------------------|----------|---------|
| 0 | - | - | - | 0.042 | 0.268 | 99.51 | - | 0.066 | 0.024 | 0.022 | 0.025 |
| 0.6 | - | - | - | 0.114 | 0.271 | 99.42 | - | 0.071 | 0.025 | 0.013 | 0.051 |
| 2.1 | - | 0.018 | 0.002 | 0.179 | 0.271 | 99.35 | - | 0.048 | 0.019 | 0.003 | 0.068 |
| 3.6 | 0.0015 | 0.016 | 0.002 | 0.207 | 0.268 | 99.21 | - | 0.110 | 0.035 | 0.020 | 0.087 |
| 6.0 | 0.0015 | 0.009 | 0.002 | 0.353 | 0.273 | 98.86 | 0.040 | 0.162 | 0.053 | 0.030 | 0.177 |
| 7.8 | 0.0015 | 0.008 | 0.002 | 0.452 | 0.274 | 98.69 | 0.044 | 0.196 | 0.067 | 0.025 | 0.206 |
| 9.6 | 0.0030 | 0.019 | 0.007 | 0.477 | 0.274 | 98.66 | 0.045 | 0.194 | 0.067 | 0.020 | 0.200 |
| 12.0 | 0.0015 | 0.013 | 0.002 | 0.575 | 0.279 | 98.44 | 0.051 | 0.222 | 0.080 | - | 0.238 |
| 15.0 | 0.0014 | 0.010 | 0.002 | 0.913 | 0.282 | 98.03 | 0.066 | 0.282 | 0.131 | 0.020 | 0.228 |
| 18.0 | 0.0014 | 0.009 | 0.002 | 1.14 | 0.298 | 97.48 | 0.079 | 0.360 | 0.186 | 0.022 | 0.385 |
| 21.0 | 0.0014 | 0.008 | 0.001 | 1.72 | 0.324 | 96.69 | 0.107 | 0.458 | 0.293 | 0.024 | 0.340 |
| 24.0 | 0.0014 | 0.009 | 0.004 | 2.53 | 0.315 | 95.03 | 0.157 | 0.616 | 0.490 | 0.027 | 0.816 |

TABLE XXVII
 PRODUCT DISTRIBUTION OF o-ETHYLPHENOL THERMOLYSIS (MOL%)
 (RUN 16, 623 K, 9.2 MPa, H₂)

| Reaction time (10 ³ s) | Benzene | Toluene | Ethyl- benzene | Phenol | o-Cresol | o-Ethyl- phenol | p-,m- Cresols | p-Ethyl- phenol | m-Ethyl- phenol | Xylenols | Heavies |
|--------------------------------------|---------|---------|-------------------|--------|----------|--------------------|------------------|--------------------|--------------------|----------|---------|
| 0 | - | - | - | 0.042 | 0.268 | 99.51 | - | 0.066 | 0.024 | 0.022 | 0.025 |
| 0.9 | - | 0.022 | 0.003 | 0.100 | 0.272 | 99.41 | - | 0.074 | 0.027 | 0.055 | |
| 2.4 | - | 0.016 | 0.010 | 0.165 | 0.267 | 99.27 | 0.039 | 0.088 | 0.031 | 0.075 | |
| 4.2 | - | 0.028 | 0.009 | 0.227 | 0.261 | 99.11 | 0.036 | 0.139 | 0.039 | 0.115 | |
| 6.0 | - | 0.014 | 0.001 | 0.369 | 0.261 | 98.92 | 0.040 | 0.173 | 0.053 | 0.163 | |
| 8.4 | - | 0.016 | 0.003 | 0.485 | 0.285 | 98.64 | 0.053 | 0.226 | 0.063 | 0.193 | |
| 10.8 | - | 0.024 | 0.011 | 0.515 | 0.319 | 98.39 | 0.071 | 0.313 | 0.127 | 0.197 | |
| 13.2 | - | 0.011 | 0.001 | 0.722 | 0.309 | 98.06 | 0.077 | 0.359 | 0.149 | 0.286 | |
| 15.6 | - | 0.020 | 0.005 | 1.02 | 0.287 | 97.77 | 0.072 | 0.348 | 0.222 | 0.251 | |
| 18.0 | - | 0.016 | 0.004 | 1.43 | 0.294 | 97.11 | 0.083 | 0.413 | 0.262 | 0.389 | |
| 21.0 | - | 0.016 | 0.003 | 1.83 | 0.308 | 96.20 | 0.104 | 0.510 | 0.348 | 0.648 | |
| 24.0 | - | 0.011 | 0.002 | 2.15 | 0.322 | 95.67 | 0.118 | 0.570 | 0.412 | 0.714 | |

TABLE XXVIII
GAS ANALYSIS FOR *o*-ETHYLPHENOL THERMOLYSIS (MOL%)

| Reaction time (10 ³ s) | C ₁ | C ₂ ⁻ | C ₂ | (C ₂ +C ₂ ⁻)/C ₁ | C ₂ ⁻ /C ₂ |
|--|----------------|-----------------------------|----------------|---|---|
| Run 15 (623 K, 9.2 MPa, N ₂) | | | | | |
| 0.6 | 0.0021 | 0.0024 | trace | - | - |
| 2.1 | .0042 | 0.0073 | trace | - | - |
| 3.6 | 0.0056 | 0.010 | trece | - | - |
| 6.0 | 0.0099 | 0.016 | 0.016 | 3.2 | 1.0 |
| 7.6 | 0.011 | 0.016 | 0.019 | 3.2 | 0.84 |
| 12.0 | 0.020 | 0.023 | 0.033 | 2.8 | 0.70 |
| 15.0 | 0.026 | 0.026 | 0.043 | 2.7 | 0.60 |
| 18.0 | 0.038 | 0.030 | 0.060 | 2.4 | 0.50 |
| 21.0 | 0.044 | 0.031 | 0.072 | 2.3 | 0.43 |
| 24.0 | 0.059 | 0.034 | 0.089 | 2.1 | 0.38 |
| Run 16 (623 K, 9.2 MPa, H ₂) | | | | | |
| 0.9 | 0.0020 | 0.0075 | 0.0029 | 2.7 | 0.86 |
| 2.4 | 0.0055 | 0.0072 | 0.0091 | 3.0 | 0.79 |
| 4.2 | 0.0071 | 0.0095 | 0.014 | 3.3 | 0.68 |
| 6.0 | 0.0074 | 0.0073 | 0.011 | 2.5 | 0.66 |
| 8.4 | 0.012 | 0.011 | 0.020 | 2.6 | 0.55 |
| 10.8 | 0.012 | 0.010 | 0.022 | 2.7 | 0.45 |
| 13.2 | 0.021 | 0.017 | 0.041 | 2.8 | 0.41 |
| 15.6 | 0.032 | 0.026 | 0.070 | 3.0 | 0.37 |
| 18.0 | 0.038 | 0.026 | 0.075 | 2.7 | 0.35 |
| 21.0 | 0.041 | 0.025 | 0.078 | 2.5 | 0.32 |

TABLE XXIX
ANALYSIS OF GAS CONDENSATES FROM o-ETHYLPHENOL THERMOLYSIS (MOL%)
(RUN 15, 623 K, 9.2 MPa, N₂)

| Reaction time (10 ³ s) | Benzene | Toluene | Ethyl- benzene | Phenol | o-Cresol | o-Ethyl- phenol | p-,m- Cresols | p-Ethyl- phenol | m-Ethyl- phenol | Xylenols | Heavies |
|--------------------------------------|---------|---------|-------------------|--------|----------|--------------------|------------------|--------------------|--------------------|----------|---------|
| 2.4 | 0.077 | 0.260 | 0.112 | 0.271 | 0.381 | 98.74 | - | 0.085 | 0.027 | - | 0.013 |
| 6.0 | - | 0.112 | 0.043 | 0.307 | 0.389 | 98.96 | - | 0.085 | 0.023 | - | 0.045 |
| 8.4 | 0.087 | 0.214 | 0.075 | 0.357 | 0.386 | 98.79 | - | 0.044 | 0.009 | - | 0.007 |
| 10.8 | - | 0.084 | 0.026 | 0.423 | 0.378 | 98.87 | - | 0.109 | 0.043 | - | 0.036 |
| 13.2 | - | 0.113 | 0.032 | 0.547 | 0.368 | 98.78 | - | 0.076 | 0.017 | - | 0.031 |
| 15.6 | - | 0.105 | 0.033 | 0.626 | 0.366 | 98.61 | 0.033 | 0.140 | 0.045 | - | 0.009 |
| 18.0 | -- | 0.040 | 0.006 | 1.354 | 0.361 | 97.83 | 0.051 | 0.228 | 0.082 | - | 0.018 |
| 24.0 | - | 0.021 | 0.002 | 2.969 | 0.380 | 95.88 | 0.082 | 0.375 | 0.163 | - | 0.095 |

TABLE XXX
 PRODUCT DISTRIBUTION OF o-ETHYLPHENOL THERMOLYSIS IN DODECANE (MOL%)
 RUN 3, 623 K, 9.2 MPa, N₂)

| Reaction time (10 ³ s) | Phenol | o-Cresol | o-Ethyl- Phenol | p-, m- Cresols | p-Ethyl- Phenol | m-Ethyl- Phenol | Xylenols & related HCs | Hvy O-compds related HCs |
|--------------------------------------|--------|----------|--------------------|-------------------|--------------------|--------------------|---------------------------|-----------------------------|
| 0 | 0.004 | 0.016 | 4.749 | 0.004 | 0.004 | 0.004 | 0.022 | 0.013 |
| 0.3 | 0.007 | 0.016 | 4.748 | 0.004 | 0.004 | 0.004 | 0.023 | 0.013 |
| 0.9 | 0.011 | 0.016 | 4.738 | - | 0.007 | 0.005 | 0.022 | 0.021 |
| 2.0 | 0.009 | 0.017 | 4.731 | 0.006 | 0.005 | 0.007 | 0.031 | 0.013 |
| 3.8 | 0.011 | 0.018 | 4.726 | 0.005 | 0.007 | 0.005 | 0.034 | 0.024 |
| 4.5 | 0.012 | 0.019 | 4.630 | 0.006 | 0.008 | 0.008 | 0.034 | 0.033 |
| 5.7 | 0.011 | 0.019 | 4.538 | 0.007 | 0.007 | 0.011 | 0.038 | 0.037 |
| 8.1 | 0.012 | 0.019 | 4.532 | 0.008 | 0.008 | 0.007 | 0.044 | 0.039 |
| 10.5 | 0.014 | 0.021 | 4.486 | - | 0.008 | 0.007 | 0.044 | 0.034 |
| 12.3 | 0.014 | 0.021 | 4.429 | 0.008 | 0.009 | 0.007 | 0.044 | 0.038 |
| 14.4 | 0.016 | 0.023 | 4.436 | 0.009 | 0.009 | 0.007 | 0.049 | 0.041 |
| 16.2 | 0.016 | 0.022 | 4.304 | 0.010 | 0.011 | 0.008 | 0.069 | 0.064 |
| 19.8 | 0.021 | 0.026 | 4.206 | 0.012 | 0.013 | 0.011 | 0.087 | 0.090 |
| 23.4 | 0.021 | 0.026 | 4.196 | 0.012 | 0.016 | 0.012 | 0.095 | 0.111 |
| 25.2 | 0.025 | 0.030 | 4.187 | 0.013 | 0.016 | 0.012 | 0.100 | 0.097 |
| 28.8 | 0.028 | 0.032 | 4.049 | 0.014 | 0.017 | 0.014 | 0.116 | 0.121 |
| 32.4 | 0.030 | 0.034 | 4.173 | 0.014 | 0.017 | 0.012 | 0.103 | 0.116 |
| 36.0 | 0.030 | 0.035 | 4.029 | 0.017 | 0.020 | 0.016 | 0.132 | 0.149 |

TABLE XXXIa
 PRODUCT DISTRIBUTION OF o-ETHYLPHENOL THERMOLYSIS IN DODECANE (MOL%)
 (RUN 6, 623 K, 9.2 MPa, N₂)

| Reaction Time (10 ³ s) | < C ₅ | C ₆ | C ₆ ⁻ | C ₇ | C ₇ ⁻ | C ₈ | C ₈ ⁻ | C ₉ | C ₉ ⁻ | C ₁₀ | C ₁₀ ⁻ | C ₁₁ | C ₁₁ ⁻ | C ₁₂ | > C ₁₂ |
|-----------------------------------|------------------|----------------|-----------------------------|----------------|-----------------------------|----------------|-----------------------------|----------------|-----------------------------|-----------------|------------------------------|-----------------|------------------------------|-----------------|-------------------|
| 0 | 0.019 | 0.015 | 0.043 | 0.018 | 0.015 | 0.008 | 0.008 | 0.015 | 0.026 | 0.001 | 0.004 | 0.087 | 0.006 | 94.20 | 0.001 |
| 0.9 | 0.029 | 0.019 | 0.064 | 0.028 | 0.033 | 0.011 | 0.011 | 0.024 | 0.054 | 0.003 | 0.011 | 0.085 | 0.014 | 94.03 | 0.001 |
| 1.5 | 0.026 | 0.029 | 0.073 | 0.039 | 0.044 | 0.014 | 0.016 | 0.039 | 0.090 | 0.007 | 0.025 | 0.091 | 0.019 | 93.91 | 0.005 |
| 2.1 | 0.026 | 0.035 | 0.090 | 0.051 | 0.058 | 0.020 | 0.034 | 0.049 | 0.088 | 0.010 | 0.037 | 0.098 | 0.026 | 93.78 | 0.008 |
| 3.3 | 0.032 | 0.046 | 0.117 | 0.051 | 0.051 | 0.020 | 0.042 | 0.065 | 0.095 | 0.007 | 0.050 | 0.107 | 0.029 | 93.69 | 0.008 |
| 4.5 | 0.035 | 0.050 | 0.136 | 0.054 | 0.071 | 0.029 | 0.052 | 0.067 | 0.102 | 0.012 | 0.057 | 0.124 | 0.037 | 93.59 | 0.010 |
| 5.7 | 0.038 | 0.044 | 0.149 | 0.061 | 0.077 | 0.034 | 0.078 | 0.073 | 0.109 | 0.012 | 0.067 | 0.140 | 0.039 | 93.55 | 0.010 |
| 6.9 | 0.045 | 0.052 | 0.145 | 0.044 | 0.079 | 0.038 | 0.062 | 0.069 | 0.097 | 0.015 | 0.061 | 0.106 | 0.031 | 93.70 | 0.003 |
| 8.1 | 0.038 | 0.050 | 0.183 | 0.051 | 0.082 | 0.052 | 0.065 | 0.075 | 0.108 | 0.025 | 0.065 | 0.114 | 0.038 | 93.51 | 0.017 |
| 9.9 | 0.058 | 0.062 | 0.177 | 0.058 | 0.071 | 0.046 | 0.068 | 0.081 | 0.116 | 0.016 | 0.071 | 0.119 | 0.038 | 93.41 | 0.019 |
| 11.7 | 0.067 | 0.069 | 0.194 | 0.056 | 0.078 | 0.049 | 0.065 | 0.086 | 0.109 | 0.017 | 0.074 | 0.114 | 0.035 | 93.42 | 0.021 |
| 13.5 | 0.058 | 0.073 | 0.200 | 0.060 | 0.082 | 0.050 | 0.070 | 0.094 | 0.117 | 0.016 | 0.061 | 0.121 | 0.038 | 93.39 | 0.025 |
| 15.3 | 0.035 | 0.089 | 0.198 | 0.070 | 0.091 | 0.061 | 0.076 | 0.104 | 0.130 | 0.020 | 0.077 | 0.120 | 0.042 | 93.31 | 0.026 |
| 17.1 | 0.070 | 0.075 | 0.211 | 0.063 | 0.098 | 0.062 | 0.073 | 0.069 | 0.105 | 0.016 | 0.058 | 0.106 | 0.028 | 93.38 | 0.030 |
| 18.9 | 0.061 | 0.073 | 0.202 | 0.067 | 0.104 | 0.073 | 0.091 | 0.103 | 0.112 | 0.022 | 0.050 | 0.101 | 0.024 | 93.35 | 0.027 |
| 20.7 | 0.064 | 0.067 | 0.181 | 0.054 | 0.088 | 0.055 | 0.067 | 0.067 | 0.125 | 0.020 | 0.037 | 0.095 | 0.021 | 93.57 | 0.026 |
| 22.5 | 0.064 | 0.067 | 0.194 | 0.062 | 0.088 | 0.059 | 0.075 | 0.074 | 0.109 | 0.015 | 0.048 | 0.103 | 0.027 | 93.49 | 0.029 |
| 24.3 | 0.070 | 0.083 | 0.204 | 0.070 | 0.091 | 0.076 | 0.076 | 0.089 | 0.131 | 0.012 | 0.050 | 0.118 | 0.030 | 93.40 | 0.032 |
| 26.1 | 0.086 | 0.091 | 0.204 | 0.061 | 0.102 | 0.075 | 0.091 | 0.075 | 0.126 | 0.016 | 0.045 | 0.106 | 0.027 | 93.45 | 0.032 |
| 27.9 | 0.045 | 0.060 | 0.217 | 0.068 | 0.084 | 0.069 | 0.075 | 0.075 | 0.140 | 0.012 | 0.060 | 0.105 | 0.031 | 93.53 | 0.032 |
| 29.7 | 0.115 | 0.104 | 0.230 | 0.086 | 0.102 | 0.087 | 0.101 | 0.089 | 0.147 | 0.009 | 0.056 | 0.099 | 0.034 | 93.42 | 0.031 |
| 31.5 | 0.077 | 0.096 | 0.230 | 0.079 | 0.100 | 0.073 | 0.089 | 0.091 | 0.134 | 0.016 | 0.061 | 0.121 | 0.037 | 93.50 | 0.037 |
| 33.3 | 0.067 | 0.098 | 0.232 | 0.084 | 0.104 | 0.081 | 0.104 | 0.087 | 0.129 | 0.017 | 0.043 | 0.101 | 0.019 | 93.50 | 0.042 |

TABLE XXXIb
 PRODUCT DISTRIBUTION OF o-ETHYLPHENOL THERMOLYSIS IN DODECANE (MOL%)
 (RUN 6, 623 K, 9.2 MPa, N₂)

| Reaction time (10 ³ s) | Benzene | Toluene | Ethyl-benzene | Phenol | o-Cresol | o-Ethyl-phenol | p-,m-Cresols | p-Ethyl-phenol | m-Ethyl-phenol | Xylenols & related HCs | Heavy O-compds & related HCs |
|-----------------------------------|---------|---------|---------------|--------|----------|----------------|--------------|----------------|----------------|------------------------|------------------------------|
| 0 | - | 0.028 | - | 0.004 | 0.015 | 5.483 | 0.006 | 0.003 | 0.004 | 0.020 | 0.013 |
| 0.9 | - | 0.025 | 0.007 | 0.007 | 0.016 | 5.472 | 0.006 | 0.004 | 0.005 | 0.019 | 0.017 |
| 1.5 | 0.010 | 0.030 | 0.014 | 0.011 | 0.018 | 5.427 | 0.008 | 0.005 | 0.008 | 0.026 | 0.015 |
| 2.1 | 0.012 | 0.036 | 0.022 | 0.014 | 0.019 | 5.409 | 0.010 | 0.007 | 0.008 | 0.032 | 0.020 |
| 3.3 | 0.011 | 0.050 | 0.027 | 0.020 | 0.019 | 5.396 | 0.008 | 0.007 | 0.005 | 0.031 | 0.018 |
| 4.5 | 0.021 | 0.051 | 0.038 | 0.020 | 0.021 | 5.340 | 0.009 | 0.008 | 0.007 | 0.032 | 0.021 |
| 5.7 | 0.023 | 0.055 | 0.048 | 0.020 | 0.022 | 5.271 | 0.010 | 0.008 | 0.008 | 0.033 | 0.021 |
| 6.9 | - | 0.050 | 0.043 | 0.021 | 0.021 | 5.228 | 0.008 | 0.008 | 0.005 | 0.035 | 0.034 |
| 8.1 | - | 0.071 | 0.030 | 0.023 | 0.022 | 5.286 | 0.009 | 0.008 | 0.007 | 0.039 | 0.028 |
| 9.9 | 0.029 | 0.086 | 0.041 | 0.025 | 0.024 | 5.286 | 0.010 | 0.009 | 0.007 | 0.039 | 0.036 |
| 11.7 | 0.027 | 0.081 | 0.045 | 0.025 | 0.022 | 5.230 | 0.010 | 0.009 | 0.005 | 0.045 | 0.041 |
| 13.5 | - | 0.088 | 0.050 | 0.028 | 0.026 | 5.224 | 0.011 | 0.011 | 0.007 | 0.050 | 0.049 |
| 15.3 | - | 0.091 | 0.066 | 0.032 | 0.027 | 5.189 | 0.012 | 0.012 | 0.008 | 0.052 | 0.055 |
| 17.1 | 0.027 | 0.071 | 0.042 | 0.035 | 0.029 | 5.180 | 0.012 | 0.013 | 0.008 | 0.068 | 0.076 |
| 18.9 | 0.029 | 0.083 | 0.052 | 0.034 | 0.029 | 5.152 | 0.013 | 0.013 | 0.008 | 0.064 | 0.067 |
| 20.7 | 0.025 | 0.060 | 0.027 | 0.035 | 0.030 | 5.126 | 0.014 | 0.015 | 0.010 | 0.068 | 0.057 |
| 22.5 | 0.031 | 0.073 | 0.037 | 0.037 | 0.030 | 5.103 | 0.014 | 0.015 | 0.010 | 0.071 | 0.074 |
| 24.3 | 0.029 | 0.088 | 0.039 | 0.037 | 0.021 | 5.033 | 0.015 | 0.016 | 0.011 | 0.079 | 0.088 |
| 26.1 | 0.025 | 0.088 | 0.035 | 0.037 | 0.030 | 4.984 | 0.014 | 0.016 | 0.010 | 0.071 | 0.093 |
| 27.9 | 0.042 | 0.099 | 0.038 | 0.037 | 0.032 | 4.934 | 0.015 | 0.015 | 0.010 | 0.088 | 0.091 |
| 29.7 | 0.025 | 0.081 | 0.031 | 0.043 | 0.035 | 4.865 | 0.015 | 0.019 | 0.012 | 0.075 | 0.093 |
| 31.5 | 0.031 | 0.086 | 0.030 | 0.041 | 0.035 | 4.805 | 0.016 | 0.019 | 0.012 | 0.086 | 0.105 |
| 33.3 | 0.031 | 0.089 | 0.035 | 0.044 | 0.037 | 4.816 | 0.018 | 0.021 | 0.014 | 0.102 | 0.092 |

TABLE XXXIIa
 PRODUCT DISTRIBUTION OF o-ETHYLPHENOL THERMOLYSIS IN DODECANE (MOL%)
 (RUN 8, 648 K, 9.2 MPa, N₂)

| Reaction Time (10 ³ s) | < C ₅ | C ₆ | C ₆ ⁼ | C ₇ | C ₇ ⁼ | C ₈ | C ₈ ⁼ | C ₉ | C ₉ ⁼ | C ₁₀ | C ₁₀ ⁼ | C ₁₁ | C ₁₁ ⁼ | C ₁₂ | > C ₁₂ |
|-----------------------------------|------------------|----------------|-----------------------------|----------------|-----------------------------|----------------|-----------------------------|----------------|-----------------------------|-----------------|------------------------------|-----------------|------------------------------|-----------------|-------------------|
| 0 | 0.045 | 0.046 | 0.140 | 0.035 | 0.091 | 0.024 | 0.073 | 0.030 | 0.048 | 0.005 | 0.017 | 0.092 | - | 94.44 | 0.010 |
| 0.9 | 0.078 | 0.065 | 0.216 | 0.052 | 0.087 | 0.049 | 0.108 | 0.055 | 0.063 | 0.007 | 0.025 | 0.099 | 0.009 | 94.13 | 0.008 |
| 1.92 | 0.099 | 0.069 | 0.230 | 0.056 | 0.095 | 0.053 | 0.121 | 0.057 | 0.061 | 0.005 | 0.024 | 0.098 | - | 94.06 | 0.015 |
| 2.82 | 0.109 | 0.204 | 0.081 | 0.076 | 0.097 | 0.111 | 0.166 | 0.078 | 0.099 | 0.009 | 0.036 | 0.099 | 0.024 | 94.03 | 0.019 |
| 3.9 | 0.099 | 0.233 | 0.130 | 0.093 | 0.120 | 0.088 | 0.189 | 0.087 | 0.114 | 0.004 | 0.031 | 0.088 | 0.018 | 93.88 | 0.011 |
| 5.7 | 0.128 | 0.079 | 0.296 | 0.100 | 0.135 | 0.105 | 0.169 | 0.094 | 0.054 | 0.006 | 0.034 | 0.102 | - | 93.90 | 0.014 |
| 7.5 | 0.144 | 0.089 | 0.370 | 0.124 | 0.168 | 0.119 | 0.201 | 0.116 | 0.067 | 0.006 | 0.036 | 0.104 | - | 93.37 | 0.083 |
| 9.3 | 0.176 | 0.127 | 0.306 | 0.130 | 0.171 | 0.131 | 0.198 | 0.136 | 0.086 | 0.007 | 0.041 | 0.105 | - | 93.48 | 0.114 |
| 11.1 | 0.156 | 0.166 | 0.499 | 0.164 | 0.198 | 0.149 | 0.271 | 0.149 | 0.092 | 0.011 | 0.051 | 0.118 | - | 92.87 | 0.151 |
| 13.2 | 0.159 | 0.207 | 0.417 | 0.173 | 0.213 | 0.170 | 0.248 | 0.171 | 0.114 | 0.011 | 0.054 | 0.085 | - | 93.09 | 0.068 |
| 15.0 | 0.150 | 0.394 | 0.176 | 0.186 | 0.239 | 0.187 | 0.328 | 0.191 | 0.127 | 0.011 | 0.057 | 0.096 | 0.029 | 92.69 | 0.204 |
| 16.8 | 0.181 | 0.271 | 0.489 | 0.206 | 0.237 | 0.217 | 0.291 | 0.196 | 0.137 | 0.015 | 0.059 | 0.090 | - | 92.78 | 0.097 |
| 18.6 | 0.201 | 0.344 | 0.401 | 0.231 | 0.260 | 0.257 | 0.382 | 0.225 | 0.179 | 0.020 | 0.072 | 0.118 | 0.045 | 92.22 | 0.230 |
| 20.4 | 0.222 | 0.358 | 0.423 | 0.243 | 0.256 | 0.250 | 0.383 | 0.233 | 0.132 | 0.012 | 0.079 | 0.117 | 0.011 | 92.36 | 0.250 |
| 22.2 | 0.263 | 0.396 | 0.625 | 0.249 | 0.286 | 0.256 | 0.337 | 0.260 | 0.198 | 0.013 | 0.085 | 0.131 | - | 91.76 | 0.291 |

TABLE-XXXIb

PRODUCT DISTRIBUTION OF o-ETHYLPHENOL THERMOLYSIS IN DODECANE (MOL%)
(RUN 8, 648 K, 9.2 MPa, N₂)

| Reaction time (10 ³ s) | Benzene | Toluene | Ethyl- benzene | Phenol | o-Cresol | o-Ethyl- phenol | p-,m- Cresols | p-Ethyl- phenol | m-Ethyl- phenol | Xylenols & related HCs | Heavy O-compds & related HCs |
|---|---------|---------|-------------------|--------|----------|--------------------|------------------|--------------------|--------------------|------------------------------|---------------------------------------|
| 0 | - | 0.003 | 0.018 | 0.011 | 0.018 | 4.789 | 0.010 | 0.004 | 0.007 | 0.019 | 0.020 |
| 0.9 | 0.039 | 0.012 | 0.024 | 0.019 | 0.020 | 4.744 | 0.011 | 0.007 | 0.010 | 0.029 | 0.034 |
| 1.92 | 0.048 | 0.007 | 0.022 | 0.025 | 0.024 | 4.685 | 0.012 | 0.011 | 0.015 | 0.037 | 0.053 |
| 2.82 | 0.023 | 0.017 | 0.038 | 0.016 | 0.018 | 4.546 | 0.011 | 0.004 | 0.018 | 0.035 | 0.034 |
| 3.9 | 0.070 | 0.018 | 0.037 | 0.018 | 0.021 | 4.530 | 0.011 | 0.008 | 0.022 | 0.035 | 0.049 |
| 5.7 | 0.011 | 0.012 | 0.020 | 0.023 | 0.024 | 4.523 | 0.013 | 0.012 | 0.023 | 0.045 | 0.076 |
| 7.5 | 0.032 | 0.013 | 0.023 | 0.048 | 0.042 | 4.503 | 0.025 | 0.020 | 0.030 | 0.069 | 0.168 |
| 9.3 | - | 0.017 | 0.016 | 0.037 | 0.038 | 4.385 | 0.023 | 0.021 | 0.031 | 0.087 | 0.137 |
| 11.1 | 0.053 | 0.020 | 0.034 | 0.046 | 0.045 | 4.378 | 0.027 | 0.025 | 0.036 | 0.106 | 0.180 |
| 13.2 | 0.019 | 0.018 | 0.039 | 0.041 | 0.043 | 4.306 | 0.026 | 0.025 | 0.034 | 0.094 | 0.178 |
| 15.0 | 0.051 | 0.020 | 0.042 | 0.060 | 0.058 | 4.235 | 0.036 | 0.033 | 0.038 | 0.144 | 0.219 |
| 16.8 | 0.025 | 0.016 | 0.044 | 0.044 | 0.051 | 4.087 | 0.032 | 0.032 | 0.038 | 0.159 | 0.213 |
| 18.6 | 0.038 | 0.035 | 0.066 | 0.060 | 0.062 | 3.926 | 0.044 | 0.041 | 0.035 | 0.218 | 0.289 |
| 20.4 | 0.046 | 0.026 | 0.043 | 0.056 | 0.064 | 3.863 | 0.044 | 0.040 | 0.031 | 0.204 | 0.250 |
| 22.2 | 0.026 | 0.021 | 0.030 | 0.105 | 0.079 | 3.787 | 0.055 | 0.052 | 0.043 | 0.302 | 0.354 |

TABLE XXXIIIa
 PRODUCT DISTRIBUTION OF o-ETHYLPHENOL THERMOLYSIS IN DODECANE (MOL%)
 (RUN 4, 673 K, 9.2 MPa, N₂)

| Reaction Time (10 ³ s) | < C ₅ | C ₆ | C ₆ ⁼ | C ₇ | C ₇ ⁼ | C ₈ | C ₈ ⁼ | C ₉ | C ₉ ⁼ | C ₁₀ | C ₁₀ ⁼ | C ₁₁ | C ₁₁ ⁼ | C ₁₂ > C ₁₂ | |
|-----------------------------------|------------------|----------------|-----------------------------|----------------|-----------------------------|----------------|-----------------------------|----------------|-----------------------------|-----------------|------------------------------|-----------------|------------------------------|-----------------------------------|-------|
| 0 | 0.208 | 0.143 | 0.377 | 0.076 | 0.228 | 0.081 | 0.144 | 0.074 | 0.047 | 0.001 | 0.017 | 0.094 | - | 89.29 | 0.006 |
| 0.9 | 0.289 | 0.176 | 0.448 | 0.140 | 0.226 | 0.146 | 0.290 | 0.161 | 0.156 | 0.013 | 0.064 | 0.111 | 0.035 | 88.96 | 0.083 |
| 2.4 | 0.427 | 0.274 | 0.648 | 0.248 | 0.359 | 0.277 | 0.403 | 0.325 | 0.128 | 0.012 | 0.082 | 0.103 | 0.034 | 88.06 | 0.249 |
| 4.2 | 0.674 | 0.497 | 0.825 | 0.365 | 0.524 | 0.373 | 0.476 | 0.357 | 0.094 | 0.012 | 0.075 | 0.095 | 0.025 | 87.28 | 0.301 |
| 4.8 | 1.363 | 0.767 | 1.139 | 0.501 | 0.543 | 0.516 | 0.577 | 0.363 | 0.213 | 0.033 | 0.150 | 0.107 | 0.027 | 84.34 | 0.590 |
| 5.28 | 2.071 | 1.117 | 1.479 | 0.640 | 0.690 | 0.610 | 0.678 | 0.385 | 0.258 | 0.021 | 0.135 | 0.097 | 0.021 | 82.38 | 0.673 |
| 6.0 | 2.898 | 1.465 | 1.566 | 0.806 | 0.936 | 0.789 | 0.917 | 0.508 | 0.379 | 0.034 | 0.201 | 0.107 | 0.027 | 79.63 | 0.888 |
| 7.2 | 3.699 | 1.729 | 1.726 | 0.931 | 0.856 | 0.766 | 0.833 | 0.425 | 0.399 | 0.031 | 0.191 | 0.099 | 0.025 | 78.60 | 0.921 |
| 8.4 | 4.185 | 1.844 | 1.740 | 1.016 | 0.811 | 0.761 | 0.848 | 0.431 | 0.404 | 0.031 | 0.197 | 0.097 | 0.024 | 78.04 | 0.944 |

TABLE XXXIIIb
 PRODUCT DISTRIBUTION OF o-ETHYLPHENOL THERMOLYSIS IN DODECANE (MOL%)
 (RUN 4, 673 K, 9.2 MPa, N₂)

| Reaction time (10 ³ s) | Benzene | Toluene | Ethyl- benzene | Phenol | o-Cresol | o-Ethyl- phenol | p-,m- Cresols | p-Ethyl- phenol | m-Ethyl- phenol | Xylenols & related HCs | Heavy O-compds & related HCs |
|---|---------|---------|-------------------|--------|----------|--------------------|------------------|--------------------|--------------------|------------------------------|---------------------------------------|
| 0 | - | 0.010 | 0.013 | 0.012 | 0.036 | 9.016 | 0.013 | 0.021 | 0.029 | 0.025 | 0.035 |
| 0.9 | 0.073 | 0.028 | 0.056 | 0.028 | 0.052 | 8.146 | 0.026 | 0.022 | 0.040 | 0.094 | 0.135 |
| 2.4 | 0.056 | 0.028 | 0.041 | 0.045 | 0.069 | 7.624 | 0.046 | 0.030 | 0.024 | 0.145 | 0.265 |
| 4.2 | - | 0.032 | 0.033 | 0.043 | 0.084 | 7.243 | 0.051 | 0.036 | 0.026 | 0.152 | 0.327 |
| 4.8 | 0.130 | 0.067 | 0.046 | 0.068 | 0.162 | 7.006 | 0.139 | 0.071 | 0.052 | 0.441 | 0.586 |
| 5.28 | 0.067 | 0.052 | 0.044 | 0.078 | 0.191 | 6.798 | 0.119 | 0.080 | 0.057 | 0.599 | 0.653 |
| 6.0 | 0.074 | 0.072 | 0.056 | 0.099 | 0.247 | 6.587 | 0.153 | 0.096 | 0.069 | 0.657 | 0.740 |
| 7.2 | 0.083 | 0.066 | 0.044 | 0.107 | 0.259 | 6.332 | 0.162 | 0.098 | 0.073 | 0.692 | 0.853 |
| 8.4 | 0.073 | 0.067 | 0.052 | 0.110 | 0.267 | 6.112 | 0.160 | 0.100 | 0.076 | 0.719 | 0.883 |

TABLE XXXIVa
 PRODUCT DISTRIBUTION OF o-ETHYLPHENOL THERMOLYSIS IN DODECANE (MOL%)
 (RUN 5, 673 K, 7.0 MPa, N₂)

| Reaction Time (10 ³ s) | < C ₅ | C ₆ | C ₆ ⁼ | C ₇ | C ₇ ⁼ | C ₈ | C ₈ ⁼ | C ₉ | C ₉ ⁼ | C ₁₀ | C ₁₀ ⁼ | C ₁₁ | C ₁₁ ⁼ | C ₁₂ | > C ₁₂ |
|-----------------------------------|------------------|----------------|-----------------------------|----------------|-----------------------------|----------------|-----------------------------|----------------|-----------------------------|-----------------|------------------------------|-----------------|------------------------------|-----------------|-------------------|
| 0 | 0.210 | 0.127 | 0.351 | 0.070 | 0.210 | 0.081 | 0.149 | 0.078 | 0.059 | 0.001 | 0.010 | 0.090 | - | 91.07 | 0.005 |
| 1.02 | 0.295 | 0.146 | 0.429 | 0.146 | 0.212 | 0.148 | 0.200 | 0.168 | 0.097 | 0.007 | 0.048 | 0.121 | - | 90.40 | 0.071 |
| 1.62 | 0.412 | 0.232 | 0.502 | 0.176 | 0.257 | 0.169 | 0.233 | 0.185 | 0.077 | 0.002 | 0.038 | 0.101 | - | 90.10 | 0.102 |
| 2.10 | 0.471 | 0.388 | 0.677 | 0.241 | 0.326 | 0.234 | 0.303 | 0.256 | 0.143 | 0.014 | 0.074 | 0.113 | 0.034 | 89.19 | 0.183 |
| 2.82 | 0.554 | 0.490 | 0.792 | 0.302 | 0.400 | 0.293 | 0.367 | 0.314 | 0.126 | 0.014 | 0.080 | 0.111 | 0.033 | 88.87 | 0.244 |
| 4.2 | 1.62 | 0.651 | 1.01 | 0.398 | 0.498 | 0.388 | 0.472 | 0.384 | 0.172 | 0.020 | 0.097 | 0.113 | 0.042 | 86.85 | 0.327 |
| 5.4 | 2.34 | 1.18 | 1.46 | 0.571 | 0.729 | 0.553 | 0.706 | 0.386 | 0.245 | 0.019 | 0.128 | 0.112 | 0.037 | 84.24 | 0.492 |
| 6.0 | 2.91 | 1.34 | 1.75 | 0.685 | 0.814 | 0.647 | 0.815 | 0.447 | 0.312 | 0.026 | 0.147 | 0.105 | 0.042 | 82.50 | 0.579 |
| 6.6 | 3.15 | 1.42 | 1.77 | 0.731 | 0.884 | 0.701 | 0.854 | 0.513 | 0.286 | 0.028 | 0.178 | 0.105 | 0.023 | 81.80 | 0.638 |
| 7.8 | 3.37 | 1.80 | 2.13 | 0.856 | 1.02 | 0.816 | 0.961 | 0.563 | 0.365 | 0.035 | 0.216 | 0.108 | 0.027 | 79.71 | 0.798 |
| 9.0 | 3.86 | 1.58 | 2.18 | 0.887 | 1.07 | 0.876 | 1.10 | 0.652 | 0.431 | 0.045 | 0.221 | 0.129 | 0.064 | 79.12 | 0.810 |
| 9.6 | 3.92 | 2.33 | 1.99 | 0.854 | 0.97 | 0.855 | 0.99 | 0.615 | 0.413 | 0.049 | 0.265 | 0.127 | 0.029 | 77.96 | 1.07 |
| 10.2 | 3.95 | 3.12 | 2.18 | 0.876 | 0.92 | 0.869 | 0.99 | 0.609 | 0.416 | 0.049 | 0.268 | 0.118 | 0.025 | 76.71 | 1.19 |
| 11.4 | 4.48 | 3.21 | 2.67 | 0.992 | 0.92 | 0.968 | 1.10 | 0.608 | 0.462 | 0.048 | 0.282 | 0.107 | 0.035 | 75.27 | 1.36 |
| 12.6 | 4.7 | 3.44 | 3.24 | 1.19 | 1.16 | 1.15 | 1.16 | 0.712 | 0.540 | 0.060 | 0.334 | 0.115 | 0.042 | 72.76 | 1.45 |

TABLE XXXIVb
 PRODUCTION DISTRIBUTION OF o-ETHYLPHENOL THERMOLYSIS IN DODECANE (MOL%)
 (RUN 5, 673 K, 7.0 MPa, N₂)

| Reaction time (10 ⁻³ s) | Benzene | Toluene | Ethyl- benzene | Phenol | o-Cresol | o-Ethyl- phenol | p-,m- Cresols | p-Ethyl- phenol | m-Ethyl- phenol | Xylenols & related HCs | Heavy O-compds & related HCs |
|--|---------|---------|-------------------|--------|----------|--------------------|------------------|--------------------|--------------------|------------------------------|---------------------------------------|
| 0 | - | 0.015 | 0.020 | 0.006 | 0.027 | 7.331 | 0.009 | 0.021 | 0.016 | 0.035 | 0.030 |
| 1.02 | 0.051 | 0.078 | 0.032 | 0.023 | 0.041 | 7.051 | 0.019 | 0.025 | 0.027 | 0.075 | 0.074 |
| 1.62 | 0.024 | 0.072 | 0.020 | 0.017 | 0.043 | 6.890 | 0.019 | 0.024 | 0.028 | 0.096 | 0.078 |
| 2.10 | 0.045 | 0.123 | 0.051 | 0.038 | 0.052 | 6.658 | 0.032 | 0.024 | 0.028 | 0.155 | 0.141 |
| 2.82 | 0.039 | 0.110 | 0.045 | 0.050 | 0.063 | 6.188 | 0.041 | 0.029 | 0.031 | 0.199 | 0.209 |
| 4.2 | 0.052 | 0.134 | 0.060 | 0.068 | 0.082 | 5.805 | 0.058 | 0.040 | 0.037 | 0.325 | 0.293 |
| 5.4 | 0.040 | 0.043 | 0.031 | 0.061 | 0.144 | 5.455 | 0.085 | 0.056 | 0.045 | 0.400 | 0.442 |
| 6.0 | 0.067 | 0.060 | 0.051 | 0.069 | 0.167 | 5.274 | 0.099 | 0.065 | 0.051 | 0.458 | 0.519 |
| 6.6 | 0.056 | 0.058 | 0.044 | 0.069 | 0.182 | 5.266 | 0.107 | 0.069 | 0.054 | 0.485 | 0.535 |
| 7.8 | 0.076 | 0.074 | 0.053 | 0.087 | 0.219 | 5.176 | 0.134 | 0.078 | 0.063 | 0.679 | 0.692 |
| 9.0 | 0.105 | 0.091 | 0.089 | 0.072 | 0.222 | 5.081 | 0.129 | 0.073 | 0.055 | 0.539 | 0.518 |
| 9.6 | 0.098 | 0.092 | 0.082 | 0.089 | 0.293 | 4.770 | 0.182 | 0.101 | 0.084 | 0.783 | 0.991 |
| 10.2 | 0.092 | 0.091 | 0.080 | 0.088 | 0.327 | 4.406 | 0.227 | 0.114 | 0.093 | 0.962 | 1.22 |
| 11.4 | 0.116 | 0.128 | 0.084 | 0.103 | 0.332 | 4.291 | 0.203 | 0.119 | 0.090 | 0.879 | 1.14 |
| 12.6 | 0.141 | 0.174 | 0.092 | 0.114 | 0.400 | 4.239 | 0.283 | 0.127 | 0.097 | 1.065 | 1.29 |

TABLE XXXVa
 PRODUCT DISTRIBUTION OF o-ETHYLPHENOL THERMOLYSIS IN DODECANE (MOL%)
 (RUN 9, 623 K, 4.7 MPa, N₂)

| Reaction Time (10 ³ s) | < C ₅ | C ₆ | C ₆ [±] | C ₇ | C ₇ [±] | C ₈ | C ₈ [±] | C ₉ | C ₉ [±] | C ₁₀ | C ₁₀ [±] | C ₁₁ | C ₁₁ [±] | C ₁₂ | > C ₁₂ |
|-----------------------------------|------------------|----------------|-----------------------------|----------------|-----------------------------|----------------|-----------------------------|----------------|-----------------------------|-----------------|------------------------------|-----------------|------------------------------|-----------------|-------------------|
| 0 | 0.016 | 0.015 | 0.047 | 0.012 | 0.018 | 0.008 | 0.039 | 0.008 | 0.008 | - | - | 0.136 | - | 94.34 | - |
| 0.6 | 0.019 | 0.017 | 0.064 | 0.016 | 0.022 | 0.011 | 0.046 | 0.014 | 0.013 | - | 0.002 | 0.127 | - | 94.27 | 0.004 |
| 1.2 | 0.019 | 0.019 | 0.073 | 0.021 | 0.031 | 0.012 | 0.062 | 0.015 | 0.016 | 0.001 | 0.005 | 0.114 | 0.011 | 94.23 | 0.003 |
| 1.8 | 0.023 | 0.021 | 0.073 | 0.018 | 0.026 | 0.014 | 0.070 | 0.016 | 0.027 | 0.001 | 0.010 | 0.101 | - | 94.18 | 0.022 |
| 2.4 | 0.026 | 0.029 | 0.079 | 0.016 | 0.035 | 0.015 | 0.060 | 0.020 | 0.036 | 0.005 | 0.014 | 0.083 | 0.014 | 94.14 | 0.024 |
| 3.6 | 0.029 | 0.038 | 0.086 | 0.021 | 0.033 | 0.014 | 0.095 | 0.027 | 0.030 | 0.006 | 0.020 | 0.083 | 0.022 | 94.15 | 0.017 |
| 4.8 | 0.029 | 0.050 | 0.118 | 0.021 | 0.035 | 0.014 | 0.083 | 0.023 | 0.027 | 0.005 | 0.012 | 0.096 | - | 94.15 | 0.042 |
| 6.0 | 0.039 | 0.052 | 0.125 | 0.019 | 0.029 | 0.017 | 0.043 | 0.020 | 0.032 | 0.001 | 0.014 | 0.094 | - | 94.12 | 0.053 |
| 7.8 | 0.045 | 0.069 | 0.137 | 0.028 | 0.048 | 0.015 | 0.080 | 0.034 | 0.043 | 0.006 | 0.021 | 0.106 | 0.023 | 94.08 | 0.038 |
| 9.6 | 0.096 | 0.069 | 0.147 | 0.037 | 0.051 | 0.032 | 0.068 | 0.031 | 0.028 | 0.002 | 0.014 | 0.104 | - | 93.99 | 0.060 |
| 12.0 | 0.106 | 0.069 | 0.149 | 0.053 | 0.071 | 0.046 | 0.080 | 0.038 | 0.043 | 0.010 | 0.040 | 0.099 | 0.030 | 93.89 | 0.063 |
| 13.9 | 0.074 | 0.067 | 0.145 | 0.044 | 0.077 | 0.040 | 0.068 | 0.036 | 0.044 | 0.010 | 0.020 | 0.098 | 0.030 | 93.89 | 0.070 |
| 15.6 | 0.077 | 0.063 | 0.184 | 0.051 | 0.074 | 0.056 | 0.087 | 0.042 | 0.056 | 0.009 | 0.015 | 0.092 | 0.027 | 93.86 | 0.074 |
| 17.4 | 0.096 | 0.069 | 0.202 | 0.054 | 0.071 | 0.063 | 0.106 | 0.043 | 0.057 | 0.002 | 0.016 | 0.093 | - | 93.91 | - |
| 19.2 | 0.098 | 0.073 | 0.209 | 0.050 | 0.081 | 0.076 | 0.114 | 0.056 | 0.059 | 0.002 | 0.019 | 0.091 | - | 93.87 | - |
| 21.0 | 0.086 | 0.079 | 0.204 | 0.052 | 0.085 | 0.078 | 0.137 | 0.057 | 0.064 | 0.005 | 0.020 | 0.090 | 0.019 | 93.82 | - |
| 22.8 | 0.080 | 0.079 | 0.210 | 0.060 | 0.084 | 0.079 | 0.153 | 0.046 | 0.071 | 0.001 | 0.014 | 0.095 | - | 93.76 | - |
| 24.6 | 0.086 | 0.073 | 0.210 | 0.060 | 0.075 | 0.087 | 0.167 | 0.050 | 0.072 | 0.001 | 0.011 | 0.086 | - | 93.78 | - |
| 26.4 | 0.115 | 0.085 | 0.213 | 0.061 | 0.080 | 0.081 | 0.180 | 0.051 | 0.081 | 0.001 | 0.011 | 0.086 | - | 93.71 | - |
| 28.8 | 0.128 | 0.114 | 0.215 | 0.067 | 0.084 | 0.078 | 0.208 | 0.052 | 0.090 | 0.001 | 0.012 | 0.084 | - | 93.67 | - |

TABLE XXXVb

PRODUCT DISTRIBUTION OF o-ETHYLPHENOL THERMOLYSIS IN DODECANE (MOL%)
(RUN 9. 623 K, 4.7 MPa, N₂)

| Reaction time (10 ³ s) | Benzene | Toluene | Ethyl- benzene | Phenol | o-Cresol | o-Ethyl- phenol | p-,m- Cresols | p-Ethyl- phenol | m-Ethyl- phenol | Xylenols & related HCs | Heavy O-compds & related HCs |
|---|---------|---------|-------------------|--------|----------|--------------------|------------------|--------------------|--------------------|------------------------------|---------------------------------------|
| 0 | - | - | 0.003 | 0.006 | 0.014 | 5.319 | 0.009 | 0.003 | 0.002 | 0.008 | 0.013 |
| 0.6 | 0.004 | - | 0.005 | 0.007 | 0.016 | 5.290 | 0.011 | 0.005 | 0.004 | 0.010 | 0.022 |
| 1.2 | 0.010 | 0.005 | 0.011 | 0.012 | 0.016 | 5.255 | 0.015 | 0.004 | 0.004 | 0.010 | 0.022 |
| 1.8 | 0.013 | 0.012 | 0.015 | 0.020 | 0.031 | 5.240 | 0.011 | 0.005 | 0.005 | 0.021 | 0.015 |
| 2.4 | 0.017 | 0.003 | 0.018 | 0.027 | 0.029 | 5.231 | 0.011 | 0.007 | 0.004 | 0.018 | 0.022 |
| 3.6 | 0.017 | 0.007 | 0.019 | 0.018 | 0.016 | 5.203 | 0.011 | 0.004 | 0.003 | 0.012 | 0.015 |
| 4.8 | 0.011 | 0.005 | 0.019 | 0.020 | 0.018 | 5.161 | 0.011 | 0.007 | 0.004 | 0.015 | 0.015 |
| 6.0 | 0.013 | 0.007 | 0.021 | 0.021 | 0.018 | 5.187 | 0.011 | 0.008 | 0.004 | 0.018 | 0.019 |
| 7.8 | 0.010 | 0.005 | 0.020 | 0.021 | 0.018 | 5.088 | 0.013 | 0.008 | 0.004 | 0.018 | 0.026 |
| 9.6 | 0.010 | 0.005 | 0.023 | 0.025 | 0.021 | 5.117 | 0.011 | 0.009 | 0.004 | 0.018 | 0.030 |
| 12.0 | 0.023 | 0.023 | 0.024 | 0.025 | 0.021 | 5.060 | 0.013 | 0.011 | 0.007 | 0.038 | 0.044 |
| 13.9 | 0.017 | 0.005 | 0.034 | 0.028 | 0.027 | 5.049 | 0.013 | 0.015 | 0.006 | 0.031 | 0.055 |
| 15.6 | 0.019 | 0.010 | 0.026 | 0.029 | 0.026 | 5.010 | 0.014 | 0.015 | 0.007 | 0.031 | 0.058 |
| 17.4 | 0.019 | 0.007 | 0.031 | 0.028 | 0.022 | 4.988 | 0.015 | 0.011 | 0.005 | 0.031 | 0.051 |
| 19.2 | 0.023 | 0.013 | 0.027 | 0.030 | 0.024 | 4.962 | 0.015 | 0.012 | 0.005 | 0.029 | 0.053 |
| 21.0 | 0.023 | 0.022 | 0.039 | 0.030 | 0.024 | 4.960 | 0.016 | 0.012 | 0.005 | 0.031 | 0.062 |
| 22.8 | 0.023 | 0.003 | 0.027 | 0.035 | 0.027 | 4.890 | 0.018 | 0.015 | 0.008 | 0.044 | 0.081 |
| 24.6 | 0.011 | 0.007 | 0.035 | 0.035 | 0.027 | 4.913 | 0.015 | 0.015 | 0.008 | 0.040 | 0.087 |
| 26.4 | 0.011 | 0.007 | 0.053 | 0.030 | 0.026 | 4.897 | 0.018 | 0.012 | 0.007 | 0.031 | 0.068 |
| 28.8 | 0.013 | 0.007 | 0.037 | 0.037 | 0.029 | 4.890 | 0.015 | 0.016 | 0.008 | 0.042 | 0.092 |

TABLE XXXVIA
 PRODUCT DISTRIBUTION OF o-ETHYLPHENOL THERMOLYSIS IN DODECANE (MOL%)
 (RUN 10, 623 K, 9.2 MPa, H₂)

| Reaction Time (10 ³ s) | < C ₅ | C ₆ | C ₆ ⁼ | C ₇ | C ₇ ⁼ | C ₈ | C ₈ ⁼ | C ₉ | C ₉ ⁼ | C ₁₀ | C ₁₀ ⁼ | C ₁₁ | C ₁₁ ⁼ | C ₁₂ | > C ₁₂ |
|-----------------------------------|------------------|----------------|-----------------------------|----------------|-----------------------------|----------------|-----------------------------|----------------|-----------------------------|-----------------|------------------------------|-----------------|------------------------------|-----------------|-------------------|
| 0 | 0.016 | 0.017 | 0.044 | 0.010 | 0.015 | 0.014 | 0.020 | 0.001 | 0.010 | - | 0.004 | 0.089 | - | 94.48 | - |
| 0.6 | 0.019 | 0.021 | 0.053 | 0.016 | 0.018 | 0.020 | 0.020 | 0.004 | 0.010 | - | 0.004 | 0.098 | - | 94.44 | - |
| 1.2 | 0.019 | 0.021 | 0.051 | 0.021 | 0.022 | 0.021 | 0.031 | 0.004 | 0.010 | - | 0.004 | 0.100 | - | 94.32 | - |
| 2.4 | 0.022 | 0.023 | 0.069 | 0.025 | 0.017 | 0.017 | 0.044 | 0.007 | 0.010 | - | 0.004 | 0.101 | - | 94.39 | - |
| 4.8 | 0.024 | 0.031 | 0.070 | 0.033 | 0.027 | 0.021 | 0.042 | 0.011 | 0.011 | 0.002 | 0.005 | 0.092 | - | 94.37 | - |
| 7.2 | 0.032 | 0.034 | 0.072 | 0.026 | 0.037 | 0.029 | 0.045 | 0.016 | 0.022 | 0.004 | 0.006 | 0.098 | - | 94.33 | - |
| 10.8 | 0.046 | 0.040 | 0.079 | 0.032 | 0.040 | 0.042 | 0.046 | 0.023 | 0.040 | 0.002 | 0.009 | 0.090 | - | 94.27 | - |
| 14.4 | 0.058 | 0.042 | 0.085 | 0.042 | 0.033 | 0.052 | 0.060 | 0.027 | 0.045 | 0.001 | 0.010 | 0.096 | - | 94.21 | - |
| 18.0 | 0.074 | 0.048 | 0.079 | 0.035 | 0.044 | 0.051 | 0.059 | 0.031 | 0.053 | 0.001 | 0.011 | 0.089 | - | 94.30 | - |
| 21.6 | 0.080 | 0.040 | 0.079 | 0.042 | 0.050 | 0.055 | 0.059 | 0.031 | 0.048 | 0.002 | 0.012 | 0.091 | - | 94.28 | - |
| 25.2 | 0.090 | 0.050 | 0.088 | 0.044 | 0.051 | 0.071 | 0.062 | 0.038 | 0.043 | 0.002 | 0.011 | 0.106 | - | 94.21 | - |
| 28.8 | 0.090 | 0.048 | 0.091 | 0.047 | 0.054 | 0.057 | 0.060 | 0.034 | 0.044 | 0.022 | 0.010 | 0.086 | - | 94.13 | - |

TABLE XXXVIb
 PRODUCT DISTRIBUTION OF o-ETHYLPHENOL THERMOLYSIS IN DODECANE (MOL%)
 (RUN 10, 623 K, 9.2 MPa, H₂)

| Reaction time (10 ³ s) | Benzene | Toluene | Ethyl- benzene | Phenol | o-Cresol | o-Ethyl- phenol | p-,m- Cresols | p-Ethyl- phenol | m-Ethyl- phenol | Xylenols & related HCs | Heavy O-compds & related HCs |
|---|---------|---------|-------------------|--------|----------|--------------------|------------------|--------------------|--------------------|------------------------------|---------------------------------------|
| 0 | 0.006 | - | 0.003 | - | 0.011 | 5.236 | - | 0.007 | 0.007 | - | 0.013 |
| 0.6 | 0.006 | - | 0.003 | 0.005 | 0.013 | 5.213 | - | 0.008 | 0.005 | - | 0.021 |
| 1.2 | 0.008 | - | 0.003 | 0.009 | 0.013 | 5.194 | - | 0.017 | 0.010 | - | 0.018 |
| 2.4 | 0.012 | 0.002 | 0.004 | 0.011 | 0.011 | 5.189 | - | 0.009 | 0.007 | - | 0.019 |
| 4.8 | 0.019 | 0.008 | 0.005 | 0.015 | 0.019 | 5.155 | - | 0.013 | 0.007 | - | 0.016 |
| 7.2 | 0.024 | 0.008 | 0.009 | 0.016 | 0.019 | 5.130 | - | 0.011 | 0.013 | - | 0.021 |
| 10.8 | 0.013 | 0.004 | 0.012 | 0.010 | 0.018 | 5.137 | - | 0.013 | 0.012 | 0.007 | 0.020 |
| 14.4 | 0.017 | 0.005 | 0.015 | 0.011 | 0.016 | 5.116 | - | 0.012 | 0.019 | 0.006 | 0.018 |
| 18.0 | 0.015 | 0.005 | 0.016 | 0.012 | 0.019 | 4.990 | - | 0.017 | 0.011 | 0.010 | 0.020 |
| 21.6 | 0.016 | 0.007 | 0.016 | 0.011 | 0.016 | 5.016 | - | 0.012 | 0.016 | 0.005 | 0.018 |
| 25.2 | 0.015 | 0.012 | 0.014 | 0.014 | 0.018 | 5.000 | - | 0.015 | 0.015 | 0.007 | 0.020 |
| 28.8 | 0.018 | 0.012 | 0.019 | 0.017 | 0.018 | 4.996 | - | 0.013 | 0.016 | 0.004 | 0.021 |

TABLE XXXVIIa
 PRODUCT DISTRIBUTION OF o-ETHYLPHENOL IN DODECANE (MOL%)
 (RUN 21, 623 K, 9.2 MPa, H₂)

| Reaction Time (10 ³ s) | < C ₅ | C ₆ | C ₆ ⁻ | C ₇ | C ₇ ⁻ | C ₈ | C ₈ ⁻ | C ₉ | C ₉ ⁻ | C ₁₀ | C ₁₀ ⁻ | C ₁₁ ⁻ | C ₁₂ [*] | > C ₁₂ |
|---|------------------|----------------|-----------------------------|----------------|-----------------------------|----------------|-----------------------------|----------------|-----------------------------|-----------------|------------------------------|------------------------------|------------------------------|-------------------|
| 0 | - | 0.002 | 0.002 | 0.002 | 0.002 | 0.002 | 0.002 | 0.001 | - | - | 0.001 | - | 94.60 | - |
| 0.9 | 0.010 | 0.006 | 0.005 | 0.004 | 0.004 | 0.003 | 0.005 | 0.001 | - | - | 0.003 | - | 94.56 | - |
| 2.4 | 0.013 | 0.008 | 0.011 | 0.004 | 0.005 | 0.005 | 0.007 | 0.004 | 0.001 | - | - | - | 94.56 | - |
| 4.2 | 0.019 | 0.010 | 0.014 | 0.005 | 0.008 | 0.006 | 0.007 | 0.006 | 0.003 | - | 0.001 | - | 94.54 | - |
| 6.0 | 0.024 | 0.017 | 0.021 | 0.009 | 0.013 | 0.008 | 0.011 | 0.009 | 0.004 | - | - | - | 94.50 | - |
| 7.8 | 0.022 | 0.019 | 0.028 | 0.010 | 0.015 | 0.009 | 0.013 | 0.009 | 0.005 | - | 0.001 | - | 94.49 | - |
| 9.6 | 0.026 | 0.019 | 0.030 | 0.012 | 0.016 | 0.012 | 0.016 | 0.008 | 0.008 | - | 0.002 | - | 94.48 | - |
| 11.4 | 0.032 | 0.017 | 0.030 | 0.012 | 0.017 | 0.012 | 0.024 | 0.008 | 0.010 | 0.001 | 0.004 | - | 94.47 | - |
| 13.2 | 0.035 | 0.025 | 0.036 | 0.014 | 0.020 | 0.014 | 0.020 | 0.009 | 0.014 | - | 0.001 | - | 94.46 | - |
| 15.0 | 0.046 | 0.018 | 0.034 | 0.013 | 0.019 | 0.014 | 0.020 | 0.011 | 0.010 | 0.001 | 0.002 | - | 94.44 | - |
| 18.6 | 0.042 | 0.031 | 0.045 | 0.018 | 0.024 | 0.017 | 0.024 | 0.012 | 0.014 | 0.001 | 0.004 | - | 94.42 | - |
| 21.0 | 0.051 | 0.031 | 0.045 | 0.018 | 0.027 | 0.020 | 0.026 | 0.022 | 0.019 | - | 0.001 | - | 94.40 | - |
| 24.0 | 0.054 | 0.033 | 0.068 | 0.025 | 0.033 | 0.026 | 0.039 | 0.026 | 0.027 | 0.001 | 0.006 | - | 94.39 | - |

* small amount of undecane merged into dodecane.

TABLE XXXVIIIb

PRODUCT DISTRIBUTION OF o-ETHYLPHENOL THERMOLYSIS IN DODECANE (MOL%)
(RUN 21, 623 K, 9.2 MPa, H₂)

| Reaction time (10 ³ s) | Benzene | Toluene | Ethyl- benzene | Phenol | o-Cresol | o-Ethyl- phenol | p-,m- Cresols | p-Ethyl- phenol | m-Ethyl- phenol | Xylenols & related HCs | Heavy O-compds & related HCs |
|---|---------|---------|-------------------|--------|----------|--------------------|------------------|--------------------|--------------------|------------------------------|---------------------------------------|
| 0 | - | - | 0.001 | - | 0.011 | 5.365 | - | 0.007 | - | - | 0.003 |
| 0.9 | 0.004 | - | 0.003 | 0.004 | 0.014 | 5.354 | - | 0.007 | - | 0.001 | 0.008 |
| 2.4 | - | - | - | 0.007 | 0.014 | 5.348 | - | 0.011 | - | 0.001 | 0.004 |
| 4.2 | - | - | - | 0.008 | 0.014 | 5.335 | - | 0.011 | - | 0.001 | 0.007 |
| 6.0 | - | - | - | 0.011 | 0.014 | 5.330 | - | 0.013 | - | 0.003 | 0.008 |
| 7.8 | - | - | - | 0.012 | 0.016 | 5.323 | - | 0.013 | - | 0.004 | 0.011 |
| 9.6 | - | 0.002 | 0.001 | 0.012 | 0.014 | 5.309 | - | 0.013 | 0.001 | 0.003 | 0.009 |
| 11.4 | - | 0.002 | 0.003 | 0.011 | 0.014 | 5.280 | - | 0.013 | 0.001 | 0.003 | 0.009 |
| 13.2 | - | 0.002 | 0.003 | 0.011 | 0.014 | 5.265 | - | 0.013 | 0.001 | 0.003 | 0.008 |
| 15.0 | - | 0.002 | 0.003 | 0.011 | 0.014 | 5.247 | - | 0.012 | 0.001 | 0.003 | 0.013 |
| 18.6 | - | 0.002 | 0.003 | 0.012 | 0.014 | 5.230 | - | 0.009 | 0.001 | 0.004 | 0.011 |
| 21.0 | - | 0.002 | 0.004 | 0.012 | 0.014 | 5.217 | - | 0.013 | 0.003 | 0.004 | 0.011 |
| 24.0 | 0.006 | 0.005 | 0.005 | 0.012 | 0.013 | 5.201 | - | 0.011 | 0.002 | 0.007 | 0.012 |

TABLE XXXVIIIa
 PRODUCT DISTRIBUTION OF o-ETHYLPHENOL THERMOLYSIS IN DODECANE (MOL%)
 (RUN 20, 623 K, 15.6 MPa, H₂)

| Reaction Time (10 ³ s) | < C ₅ | C ₆ | C ₆ ⁼ | C ₇ | C ₇ ⁼ | C ₈ | C ₈ ⁼ | C ₉ | C ₉ ⁼ | C ₁₀ | C ₁₀ ⁼ | C ₁₁ ⁼ | C ₁₂ [*] | > C ₁₂ |
|-----------------------------------|------------------|----------------|-----------------------------|----------------|-----------------------------|----------------|-----------------------------|----------------|-----------------------------|-----------------|------------------------------|------------------------------|------------------------------|-------------------|
| 0 | 0.003 | 0.004 | 0.006 | 0.004 | 0.054 | 0.012 | 0.013 | 0.005 | 0.015 | - | 0.002 | - | 94.30 | - |
| 0.9 | 0.003 | 0.004 | 0.006 | | 0.053 | 0.014 | 0.008 | 0.005 | 0.014 | - | 0.001 | - | 94.32 | - |
| 2.4 | 0.010 | 0.006 | 0.011 | 0.002 | 0.060 | 0.016 | 0.011 | 0.006 | 0.015 | - | 0.002 | - | 94.30 | - |
| 4.2 | 0.010 | 0.010 | 0.014 | | 0.059 | 0.021 | 0.007 | 0.005 | 0.009 | - | 0.002 | - | 94.30 | - |
| 6.0 | 0.013 | 0.015 | 0.021 | | 0.057 | 0.026 | 0.008 | 0.012 | 0.010 | - | 0.002 | - | 94.28 | - |
| 7.8 | 0.019 | 0.016 | 0.026 | | 0.071 | 0.034 | 0.010 | 0.015 | 0.017 | - | 0.005 | - | 94.23 | - |
| 9.6 | 0.026 | 0.014 | 0.020 | | 0.073 | | 0.036 | 0.011 | 0.006 | - | 0.002 | - | 94.24 | - |
| 11.4 | 0.035 | 0.023 | 0.032 | | 0.075 | | 0.049 | | 0.019 | - | 0.022 | - | 94.22 | - |
| 13.2 | 0.051 | 0.029 | 0.038 | | 0.075 | | 0.052 | | 0.020 | - | 0.002 | - | 94.18 | - |
| 15.0 | 0.051 | 0.031 | 0.034 | | 0.080 | | 0.056 | | 0.020 | - | 0.002 | - | 94.18 | - |
| 18.6 | 0.058 | 0.035 | 0.040 | | 0.079 | | 0.061 | | 0.032 | - | 0.002 | - | 94.14 | - |
| 24.0 | 0.074 | 0.044 | 0.053 | | 0.071 | | 0.063 | | 0.028 | - | 0.002 | - | 94.14 | - |

* small amount of undecane merged into dodecane.

TABLE XXXVIIIb
 PRODUCT DISTRIBUTION OF o-ETHYLPHENOL IN DODECANE (MOL%)
 (RUN 20, 623 K, 15.6 MPa, H₂)

| Reaction time (10 ³ s) | Benzene | Toluene | Ethyl- benzene | Phenol | o-Cresol | o-Ethyl- phenol | p-,m- Cresols | p-Ethyl- phenol | m-Ethyl- phenol | Xylenols & related HCs | Heavy O-compds & related HCs |
|---|---------|---------|-------------------|--------|----------|--------------------|------------------|--------------------|--------------------|------------------------------|---------------------------------------|
| 0 | - | - | 0.004 | 0.004 | 0.018 | 5.521 | - | 0.023 | 0.003 | - | 0.004 |
| 0.9 | - | - | - | 0.004 | 0.016 | 5.517 | - | 0.025 | 0.001 | - | - |
| 2.4 | - | - | 0.004 | 0.025 | 0.017 | 5.501 | - | 0.024 | 0.002 | - | 0.004 |
| 4.2 | - | - | 0.002 | 0.007 | 0.016 | 5.500 | - | 0.033 | 0.003 | - | - |
| 6.0 | - | - | 0.003 | 0.020 | 0.019 | 5.492 | - | 0.035 | 0.005 | - | 0.003 |
| 7.8 | - | - | 0.005 | 0.012 | 0.016 | 5.481 | - | 0.039 | 0.003 | - | 0.001 |
| 9.6 | 0.029 | - | - | 0.012 | 0.020 | 5.459 | - | 0.044 | 0.005 | - | 0.004 |
| 11.4 | - | - | - | 0.012 | 0.016 | 5.467 | - | 0.039 | 0.003 | - | 0.001 |
| 13.2 | - | 0.002 | - | 0.016 | 0.018 | 5.463 | - | 0.041 | 0.008 | - | - |
| 15.0 | - | 0.002 | - | 0.014 | 0.018 | 5.464 | - | 0.036 | 0.005 | - | - |
| 18.6 | 0.019 | 0.005 | - | 0.018 | 0.019 | 5.445 | - | 0.040 | 0.007 | - | - |
| 24.0 | - | 0.002 | - | 0.025 | 0.024 | 5.421 | - | 0.044 | 0.008 | - | 0.003 |

TABLE XXXIX
 GAS ANALYSIS FOR o-ETHYLPHENOL THERMOLYSIS IN DODECANE (MOL%)

| Reaction Time (10 ³ s) | C ₁ | C ₂ ⁼ | C ₂ | C ₃ ⁼ | C ₃ | C ₄ ⁼ | C ₄ | (C ₂ +C ₂ ⁼)/C ₁ | C ₂ ⁼ /C ₂ |
|--|----------------|-----------------------------|----------------|-----------------------------|----------------|-----------------------------|----------------|---|---|
| (Run 5, 673 K, 7.0 MPa, N ₂) | | | | | | | | | |
| 6.0 | 0.084 | 0.016 | 0.19 | 0.11 | 0.054 | 0.036 | 0.033 | 2.5 | .08 |
| 7.8 | 0.14 | 0.030 | 0.33 | 0.18 | 0.18 | 0.49 | 0.051 | 2.6 | .09 |
| 11.4 | 0.17 | trace | 0.68 | 0.70 | 0.80 | 0.13 | 0.050 | 4.0 | - |
| 12.9 | 0.27 | 0.052 | 0.72 | 0.50 | 0.56 | 0.21 | 0.26 | 2.9 | .07 |
| (Run 21, 623 K, 9.2 MPa, H ₂) | | | | | | | | | |
| 0.9 | 0.0084 | 0.0014 | 0.0012 | 0.0087 | 0.0078 | 0.0049 | 0.0044 | - | - |
| 4.2 | 0.010 | | 0.026 | 0.024 | 0.018 | 0.016 | 0.016 | 2.6 | - |
| 7.8 | 0.016 | 0.0042 | 0.041 | 0.029 | 0.025 | 0.021 | 0.019 | 2.8 | 0.1 |
| 11.4 | 0.021 | 0.0076 | 0.080 | 0.055 | 0.050 | 0.040 | 0.040 | 4.2 | 0.1 |
| 15.0 | 0.028 | 0.0085 | 0.092 | 0.062 | 0.055 | 0.044 | 0.048 | 3.6 | .09 |
| 21.0 | 0.021 | 0.0080 | 0.101 | 0.070 | 0.066 | 0.058 | 0.061 | 5.1 | .08 |
| 24.0 | 0.028 | 0.0064 | 0.078 | 0.055 | 0.044 | 0.042 | 0.058 | 3.0 | .08 |
| (Run 20, 623 K, 15.6 MPa, H ₂) | | | | | | | | | |
| 0.9 | 0.013 | - | - | - | - | - | - | - | - |
| 4.2 | 0.022 | 0.0016 | 0.016 | 0.014 | 0.0095 | 0.0071 | 0.0070 | 0.8 | 0.1 |
| 7.8 | 0.026 | 0.0022 | 0.024 | 0.021 | 0.013 | 0.011 | 0.010 | 1.0 | .09 |
| 11.4 | 0.016 | 0.0011 | 0.014 | 0.012 | 0.0074 | 0.0052 | 0.0051 | 0.9 | .08 |
| 15.0 | 0.0084 | 0.0020 | 0.025 | 0.020 | 0.011 | 0.012 | 0.012 | 3.2 | .08 |
| 18.6 | 0.0077 | 0.0001 | 0.013 | 0.013 | 0.0076 | 0.0048 | 0.0056 | 1.7 | - |
| 24.0 | 0.0006 | 0.0002 | 0.022 | 0.023 | 0.012 | 0.0071 | 0.0076 | - | - |

TABLE XLa
 PRODUCT DISTRIBUTION OF p-ETHYLPHENOL THERMOLYSIS IN DODECANE (MOL%)
 (RUN 17, 623 K, 9.2 MPa, N₂)

| Reaction Time (10 ³ s) | < C ₅ | C ₆ | C ₆ ⁼ | C ₇ | C ₇ ⁼ | C ₈ | C ₈ ⁼ | C ₉ | C ₉ ⁼ | C ₁₀ | C ₁₀ ⁼ | C ₁₁ ⁼ | C ₁₂ [*] | > C ₁₂ |
|-----------------------------------|------------------|----------------|-----------------------------|----------------|-----------------------------|----------------|-----------------------------|----------------|-----------------------------|-----------------|------------------------------|------------------------------|------------------------------|-------------------|
| 0 | 0.006 | 0.004 | 0.006 | - | - | - | - | 0.005 | 0.008 | - | 0.003 | - | 94.15 | 0.007 |
| 0.9 | 0.010 | 0.004 | 0.009 | - | - | 0.009 | 0.005 | 0.003 | 0.009 | - | 0.003 | - | 94.13 | 0.007 |
| 2.4 | 0.019 | 0.013 | 0.017 | - | 0.007 | 0.005 | 0.015 | 0.011 | 0.012 | 0.004 | 0.002 | 0.006 | 94.06 | 0.010 |
| 4.2 | 0.028 | 0.016 | 0.021 | - | 0.018 | 0.020 | 0.021 | 0.013 | 0.013 | 0.007 | 0.003 | 0.008 | 93.97 | 0.009 |
| 6.0 | 0.032 | 0.035 | 0.032 | 0.004 | 0.026 | 0.023 | 0.028 | 0.014 | 0.013 | 0.005 | 0.006 | 0.010 | 93.99 | 0.006 |
| 7.8 | 0.038 | 0.035 | 0.042 | 0.009 | 0.020 | 0.022 | 0.030 | 0.011 | 0.016 | 0.005 | 0.004 | 0.004 | 93.96 | 0.006 |
| 9.6 | 0.041 | 0.037 | 0.044 | 0.010 | 0.040 | 0.026 | 0.036 | 0.022 | 0.018 | 0.011 | 0.007 | 0.003 | 93.90 | 0.010 |
| 11.4 | 0.048 | 0.031 | 0.051 | 0.014 | 0.055 | 0.026 | 0.047 | 0.019 | 0.018 | - | 0.006 | - | 93.92 | 0.008 |
| 13.2 | 0.051 | 0.042 | 0.053 | 0.018 | 0.064 | 0.021 | 0.049 | 0.020 | 0.019 | 0.001 | 0.007 | - | 93.87 | 0.003 |
| 15.0 | 0.054 | 0.039 | 0.055 | 0.019 | 0.073 | 0.027 | 0.052 | 0.023 | 0.027 | 0.001 | 0.007 | 0.001 | 93.85 | 0.004 |
| 16.8 | 0.057 | 0.037 | 0.053 | 0.019 | 0.083 | 0.027 | 0.055 | 0.028 | 0.028 | - | 0.015 | - | 93.84 | 0.004 |
| 18.6 | 0.057 | 0.039 | 0.070 | 0.023 | 0.082 | 0.033 | 0.060 | 0.029 | 0.031 | 0.001 | 0.010 | 0.001 | 93.81 | 0.003 |
| 20.4 | 0.061 | 0.046 | 0.070 | 0.025 | 0.087 | 0.033 | 0.073 | 0.030 | 0.040 | - | 0.019 | 0.001 | 93.78 | 0.005 |
| 22.2 | 0.048 | 0.041 | 0.089 | 0.031 | 0.087 | 0.039 | 0.070 | 0.032 | 0.040 | 0.007 | 0.022 | 0.009 | 93.70 | 0.008 |
| 24.0 | 0.061 | 0.044 | 0.094 | 0.035 | 0.091 | 0.035 | 0.075 | 0.034 | 0.041 | - | 0.020 | 0.010 | 93.73 | 0.006 |

* small amount of undecane merged into dodecane.

TABLE XLb
 PRODUCT DISTRIBUTION OF p-ETHYLPHENOL THERMOLYSIS IN DODECANE (MOL%)
 (RUN 17, 623 K, 9.2 MPa, N₂)

| Reaction time (10 ³ s) | Benzene | Toluene | Ethyl-benzene | Phenol | o-Cresol | o-Ethyl-phenol | p-,m-Cresols | p-Ethyl-phenol | m-Ethyl-phenol | Xylenols & related HCs | Heavy O-compds & related HCs |
|-----------------------------------|---------|---------|---------------|--------|----------|----------------|--------------|----------------|----------------|------------------------|------------------------------|
| 0 | - | - | - | - | 0.0032 | 0.019 | - | 5.698 | 0.079 | - | 0.015 |
| 0.6 | - | - | 0.001 | - | 0.0032 | 0.022 | - | 5.694 | 0.078 | - | 0.015 |
| 2.4 | - | - | 0.005 | - | 0.0064 | 0.021 | - | 5.678 | 0.080 | - | 0.020 |
| 4.2 | - | 0.015 | 0.007 | - | 0.0032 | 0.019 | - | 5.673 | 0.066 | - | 0.027 |
| 6.0 | - | 0.018 | 0.004 | - | 0.0016 | 0.025 | - | 5.663 | 0.053 | 0.001 | 0.015 |
| 7.8 | 0.026 | 0.013 | 0.005 | 0.0017 | 0.0031 | 0.030 | - | 5.638 | 0.054 | 0.001 | 0.024 |
| 9.6 | - | 0.028 | 0.007 | 0.0018 | 0.0048 | 0.030 | - | 5.619 | 0.068 | - | 0.034 |
| 11.4 | - | - | 0.005 | 0.0018 | 0.0032 | 0.036 | - | 5.610 | 0.078 | 0.009 | 0.024 |
| 13.2 | - | 0.025 | - | 0.0018 | 0.0032 | 0.047 | - | 5.576 | 0.080 | 0.010 | 0.035 |
| 15.0 | - | - | 0.007 | 0.0035 | 0.0032 | 0.053 | - | 5.574 | 0.081 | 0.010 | 0.038 |
| 16.8 | - | - | - | 0.0035 | 0.0032 | 0.067 | - | 5.569 | 0.077 | 0.007 | 0.029 |
| 18.6 | - | 0.012 | 0.008 | 0.0035 | 0.0032 | 0.066 | - | 5.560 | 0.063 | 0.012 | 0.025 |
| 20.4 | - | - | 0.016 | 0.0035 | 0.0032 | 0.060 | - | 5.550 | 0.066 | 0.013 | 0.024 |
| 22.2 | - | 0.016 | 0.018 | 0.0053 | 0.0048 | 0.064 | - | 5.531 | 0.085 | 0.028 | 0.026 |
| 24.0 | - | - | 0.018 | 0.0053 | 0.0050 | 0.065 | - | 5.527 | 0.085 | 0.032 | 0.026 |

TABLE XLIa
 PRODUCT DISTRIBUTION OF m-ETHYLPHENOL THERMOLYSIS IN DODECANE (MOL%)
 (RUN 18, 623 K, 9.2 MPa, N₂)

| Reaction Time (10 ³ s) | < c ₅ | c ₆ | c ₆ ⁼ | c ₇ | c ₇ ⁼ | c ₈ | c ₈ ⁼ | c ₉ | c ₉ ⁼ | c ₁₀ | c ₁₀ ⁼ | c ₁₁ | c ₁₁ ⁼ | c ₁₂ | > c ₁₂ |
|-----------------------------------|------------------|----------------|-----------------------------|----------------|-----------------------------|----------------|-----------------------------|----------------|-----------------------------|-----------------|------------------------------|-----------------|------------------------------|-----------------|-------------------|
| 0 | 0.029 | 0.019 | 0.032 | | 0.089 | 0.021 | 0.046 | 0.015 | 0.023 | 0.021 | 0.007 | 0.062 | - | 93.42 | 0.001 |
| 0.9 | 0.029 | 0.019 | 0.032 | | 0.108 | 0.021 | 0.049 | 0.015 | 0.027 | 0.005 | 0.007 | 0.068 | 0.007 | 93.39 | 0.001 |
| 2.4 | 0.029 | 0.019 | 0.032 | | 0.126 | 0.021 | 0.046 | 0.015 | 0.023 | 0.005 | 0.007 | 0.062 | - | 93.41 | 0.004 |
| 4.2 | 0.029 | 0.029 | 0.047 | | 0.150 | 0.030 | 0.067 | 0.023 | 0.031 | 0.006 | 0.020 | 0.075 | 0.008 | 93.27 | 0.003 |
| 6.0 | 0.035 | 0.029 | 0.053 | | 0.170 | 0.032 | 0.062 | 0.030 | 0.035 | 0.004 | 0.017 | 0.076 | 0.007 | 93.23 | 0.003 |
| 7.8 | 0.067 | 0.042 | 0.062 | | 0.195 | 0.035 | 0.062 | 0.034 | 0.033 | 0.006 | 0.021 | 0.077 | 0.008 | 93.15 | 0.003 |
| 9.6 | 0.048 | 0.042 | 0.068 | | 0.213 | 0.033 | 0.057 | 0.030 | 0.030 | - | 0.020 | 0.058 | - | 93.21 | 0.003 |
| 11.4 | 0.064 | 0.039 | 0.083 | | 0.213 | 0.038 | 0.066 | 0.032 | 0.032 | 0.001 | 0.011 | 0.069 | - | 93.14 | 0.003 |
| 15.0 | 0.083 | 0.054 | 0.083 | | 0.216 | 0.041 | 0.070 | 0.036 | 0.033 | 0.001 | 0.010 | 0.068 | - | 93.10 | 0.006 |
| 18.9 | 0.105 | 0.062 | 0.093 | | 0.133 | 0.035 | 0.071 | 0.050 | 0.044 | 0.006 | 0.021 | 0.090 | - | 93.08 | 0.008 |
| 21.3 | 0.118 | 0.058 | 0.091 | | 0.198 | 0.047 | 0.080 | 0.046 | 0.037 | - | 0.015 | 0.076 | - | 93.02 | 0.009 |
| 24.0 | 0.108 | 0.075 | 0.102 | | 0.203 | 0.058 | 0.092 | 0.051 | 0.037 | 0.001 | 0.017 | 0.079 | 0.006 | 92.97 | 0.011 |

TABLE XL1b
 PRODUCT DISTRIBUTION OF m-ETHYLPHENOL THERMOLYSIS IN DODECANE (MOL%)
 (RUN 18, 623 K, 9.2 MPa, N₂)

| Reaction time (10 ³ s) | Benzene | Toluene | Ethyl- benzene | Phenol | o-Cresol | o-Ethyl- phenol | p-,m- Cresols | p-Ethyl- phenol | m-Ethyl- phenol | Xylenols & related HCs | Heavy O-compds & related HCs |
|---|---------|---------|-------------------|--------|----------|--------------------|------------------|--------------------|--------------------|------------------------------|---------------------------------------|
| 0 | - | - | 0.007 | - | - | 0.018 | - | - | 6.205 | - | 0.0013 |
| 0.4 | - | 0.015 | 0.008 | - | - | 0.018 | - | - | 6.185 | - | 0.0013 |
| 2.4 | - | - | 0.007 | - | - | 0.016 | - | - | 6.175 | - | 0.0013 |
| 4.2 | - | 0.018 | 0.004 | - | - | 0.015 | - | - | 6.170 | - | 0.0026 |
| 6.0 | - | 0.017 | 0.009 | - | - | 0.015 | - | - | 6.169 | - | 0.0053 |
| 7.8 | - | 0.015 | 0.012 | - | - | 0.014 | 0.0016 | - | 6.164 | - | 0.0066 |
| 9.6 | - | - | 0.004 | - | - | 0.014 | 0.0016 | - | 6.160 | - | 0.0066 |
| 11.4 | - | - | 0.007 | 0.0018 | 0.0016 | 0.014 | 0.0016 | - | 6.155 | 0.016 | 0.0065 |
| 15.0 | - | - | 0.005 | 0.0018 | 0.0016 | 0.012 | 0.0048 | - | 6.140 | 0.017 | 0.021 |
| 18.9 | - | - | 0.008 | 0.0053 | 0.0032 | 0.014 | 0.0080 | - | 6.113 | 0.019 | 0.030 |
| 21.3 | - | - | 0.008 | 0.0071 | 0.0064 | 0.018 | 0.0080 | 0.0040 | 6.008 | 0.021 | 0.035 |
| 24.0 | - | 0.013 | 0.009 | 0.0053 | 0.0048 | 0.012 | 0.0080 | 0.0013 | 6.088 | 0.023 | 0.025 |

TABLE XLIIa
 PRODUCT DISTRIBUTION OF m-ETHYLPHENOL THERMOLYSIS IN DODECANE (MOL%)
 (RUN 19, 623 K, 9.2 MPa, H₂)

| Reaction Time (10 ³ s) | < C ₅ | C ₆ | C ₆ ⁼ | C ₇ | C ₇ ⁼ | C ₈ | C ₈ ⁼ | C ₉ | C ₉ ⁼ | C ₁₀ | C ₁₀ ⁼ | C ₁₁ | C ₁₁ ⁼ | C ₁₂ | > C ₁₂ |
|-----------------------------------|------------------|----------------|-----------------------------|----------------|-----------------------------|----------------|-----------------------------|----------------|-----------------------------|-----------------|------------------------------|-----------------|------------------------------|-----------------|-------------------|
| 0 | 0.010 | 0.008 | 0.024 | 0.011 | 0.009 | 0.017 | 0.033 | 0.014 | 0.018 | 0.004 | 0.025 | 0.049 | 0.005 | 93.88 | 0.003 |
| 0.9 | 0.013 | 0.010 | 0.026 | 0.012 | 0.011 | 0.018 | 0.033 | 0.013 | 0.018 | 0.010 | 0.031 | 0.085 | 0.013 | 93.83 | 0.003 |
| 2.4 | 0.016 | 0.010 | 0.026 | 0.014 | 0.013 | 0.018 | 0.034 | 0.015 | 0.018 | 0.012 | 0.029 | 0.075 | 0.011 | 93.83 | 0.002 |
| 4.2 | 0.019 | 0.015 | 0.023 | 0.016 | 0.015 | 0.018 | 0.036 | 0.012 | 0.022 | - | 0.005 | 0.072 | - | 93.89 | 0.002 |
| 6.0 | 0.026 | 0.019 | 0.030 | 0.018 | 0.016 | 0.018 | 0.042 | 0.013 | 0.022 | 0.001 | 0.010 | 0.074 | - | 93.85 | 0.002 |
| 7.8 | 0.019 | 0.017 | 0.030 | 0.018 | 0.011 | 0.021 | 0.044 | 0.015 | 0.026 | 0.001 | 0.011 | 0.077 | - | 93.85 | 0.003 |
| 9.0 | 0.026 | 0.019 | 0.030 | 0.012 | 0.015 | 0.020 | 0.041 | 0.015 | 0.024 | - | 0.007 | 0.069 | - | 93.86 | 0.005 |
| 11.4 | 0.029 | 0.023 | 0.038 | 0.019 | 0.016 | 0.023 | 0.046 | 0.016 | 0.022 | 0.001 | 0.010 | 0.080 | - | 93.81 | 0.005 |
| 13.2 | 0.026 | 0.021 | 0.032 | 0.012 | 0.015 | 0.018 | 0.042 | 0.015 | 0.027 | - | 0.006 | 0.067 | - | 93.77 | 0.007 |
| 15.0 | 0.016 | 0.019 | 0.034 | 0.012 | 0.020 | 0.021 | 0.041 | 0.016 | 0.030 | - | 0.006 | 0.074 | - | 93.76 | 0.002 |
| 16.8 | 0.022 | 0.021 | 0.032 | 0.012 | 0.020 | 0.023 | 0.041 | 0.020 | 0.031 | 0.001 | 0.009 | 0.086 | - | 93.74 | 0.002 |
| 18.6 | 0.026 | 0.021 | 0.032 | 0.012 | 0.018 | 0.021 | 0.044 | 0.023 | 0.035 | - | 0.005 | 0.081 | - | 93.65 | 0.008 |
| 20.4 | 0.035 | 0.025 | 0.034 | 0.014 | 0.020 | 0.020 | 0.046 | 0.023 | 0.032 | - | 0.004 | 0.100 | - | 93.71 | 0.003 |
| 24.0 | 0.029 | 0.023 | 0.038 | 0.021 | 0.024 | 0.020 | 0.047 | 0.024 | 0.028 | 0.001 | 0.012 | 0.097 | - | 93.61 | 0.003 |

TABLE XLIIB
 PRODUCT DISTRIBUTION OF m-ETHYLPHENOL THERMOLYSIS IN DODECANE (MOL%)
 (RUN 19, 623 K, 9.2 MPa, H₂)

| Reaction time (10 ³ s) | Benzene | Toluene | Ethyl- benzene | Phenol | o-Cresol | o-Ethyl- phenol | p-,m- Cresols | p-Ethyl- phenol | m-Ethyl- phenol | Xylenols & related HCs | Heavy O-compds & related HCs |
|---|---------|---------|-------------------|--------|----------|--------------------|------------------|--------------------|--------------------|------------------------------|---------------------------------------|
| 0 | - | 0.015 | 0.007 | - | - | 0.014 | - | - | 5.858 | - | 0.0013 |
| 0.9 | - | - | 0.018 | - | - | 0.010 | - | - | 5.850 | - | - |
| 2.4 | - | - | 0.022 | - | - | 0.010 | - | - | 5.845 | - | - |
| 4.2 | - | - | 0.003 | 0.0018 | - | 0.008 | - | - | 5.843 | - | - |
| 6.0 | - | - | 0.005 | 0.0018 | - | 0.008 | - | - | 5.842 | - | - |
| 7.8 | - | - | 0.007 | 0.0018 | - | 0.008 | - | - | 5.839 | - | - |
| 9.0 | - | - | 0.004 | 0.0035 | - | 0.011 | - | - | 5.836 | - | - |
| 11.4 | - | 0.010 | 0.007 | 0.0035 | - | 0.011 | - | - | 5.829 | - | - |
| 13.2 | - | - | 0.003 | 0.0035 | 0.002 | 0.011 | - | - | 5.833 | - | 0.0013 |
| 15.0 | 0.011 | - | 0.004 | 0.0018 | - | 0.010 | - | - | 5.827 | - | 0.0039 |
| 16.8 | 0.010 | - | 0.004 | 0.0018 | - | 0.010 | - | - | 5.825 | - | 0.0039 |
| 18.6 | - | - | 0.002 | 0.0018 | - | 0.010 | - | - | 5.827 | - | 0.0026 |
| 20.4 | - | - | 0.006 | 0.0035 | - | 0.010 | - | - | 5.820 | - | 0.0039 |
| 24.0 | 0.008 | - | 0.008 | 0.0035 | - | 0.010 | - | - | 5.801 | - | 0.017 |

TABLE XLIII
GAS ANALYSIS FOR p- AND ETHYLPHENOLS THERMOLYSES IN DODECANE (MOL%)

| Reaction Time (10^3 s) | C ₁ | C ₂ ⁼ | C ₂ | C ₃ ⁼ | C ₃ | C ₄ ⁼ | C ₄ |
|---|----------------|-----------------------------|----------------|-----------------------------|----------------|-----------------------------|----------------|
| (Run 17, 623 K, 9.2 MPa, N ₂) | | | | | | | |
| 0.9 | 0.0061 | 0.0002 | 0.0024 | 0.0095 | | trace | trace |
| 4.2 | 0.0091 | 0.0005 | 0.0066 | 0.063 | 0.0054 | 0.0040 | 0.0036 |
| 7.8 | 0.0086 | 0.0007 | 0.011 | 0.011 | 0.0094 | 0.0081 | 0.0069 |
| 11.4 | 0.0094 | 0.0004 | 0.0066 | 0.0065 | 0.0056 | 0.0043 | 0.0035 |
| 15.0 | 0.0090 | 0.0003 | 0.0061 | 0.0062 | 0.0054 | 0.0042 | 0.0037 |
| 18.6 | 0.011 | 0.0005 | 0.0090 | 0.0091 | 0.0077 | 0.0064 | 0.0054 |
| 24.0 | 0.0098 | 0.0003 | 0.012 | 0.011 | 0.0098 | 0.0056 | 0.0064 |
| (Run 18, 623 K, 9.2 MPa, N ₂) | | | | | | | |
| 0.9 | 0.0039 | 0.0003 | 0.0049 | 0.0047 | 0.0040 | 0.0044 | 0.0032 |
| 4.2 | 0.0071 | 0.0008 | 0.014 | 0.014 | 0.012 | 0.0098 | 0.013 |
| 7.8 | 0.0096 | 0.0012 | 0.022 | 0.022 | 0.019 | 0.016 | 0.014 |
| 9.6 | 0.016 | 0.0021 | 0.041 | 0.040 | 0.035 | 0.030 | 0.026 |
| 11.4 | 0.015 | 0.0022 | 0.045 | 0.046 | 0.040 | 0.037 | 0.033 |
| 15.0 | 0.017 | 0.0021 | 0.044 | 0.044 | 0.039 | 0.035 | 0.032 |
| 18.9 | 0.020 | 0.0025 | 0.053 | 0.054 | 0.047 | 0.044 | 0.040 |
| 24.0 | 0.042 | 0.0018 | 0.045 | 0.046 | 0.041 | 0.030 | 0.029 |
| (Run 19, 623 K, 9.2 MPa, H ₂) | | | | | | | |
| 0.9 | 0.014 | 0.0003 | 0.0052 | 0.0045 | 0.0036 | 0.0025 | 0.0022 |
| 4.2 | 0.0061 | 0.0001 | 0.0076 | 0.0074 | 0.0020 | 0.0014 | 0.0013 |
| 7.8 | 0.011 | 0.0010 | 0.021 | 0.023 | 0.017 | 0.019 | 0.014 |
| 11.4 | 0.0098 | 0.0008 | 0.018 | 0.020 | 0.015 | 0.013 | 0.012 |
| 13.2 | 0.012 | 0.0007 | 0.015 | 0.020 | 0.014 | 0.013 | 0.012 |
| 15.0 | 0.012 | 0.0010 | 0.024 | 0.030 | 0.021 | 0.021 | 0.019 |
| 20.4 | 0.0084 | 0.0008 | 0.021 | 0.030 | 0.019 | 0.016 | 0.016 |
| 24.0 | 0.017 | 0.0007 | 0.020 | 0.029 | 0.018 | 0.016 | 0.016 |

APPENDIX C
ESTIMATION OF DATA ACCURACY

TABLE XLIV
ERROR ESTIMATION OF GC ANALYSIS

| Component | Concentration (mole% or gas) (wt.% for liquid) | Analytical data (Peak area) | Sample Standard deviation (%) | Confidence limits (%) |
|---------------|--|--|--|--------------------------|
| Ethane | 1.0 | 812.7, 809.5, 782.6, 782.1, 810.4, 788.1 | 1.85 | ± 4.8 |
| Ethane | 0.25 | 200.0, 199.0 | 0.35 | ± 4.5 |
| Ethane | 0.125 | 103.6, 107.4, 105.6 | 1.8 | ± 7.8 |
| Ethane | 0.031 | 29.6, 30.1, 30.7 | 1.8 | ± 7.2 |
| Dodecane | 99.9 | 9911954, 9920085, 9920614, 9913508, 9911954, 9910244 | 0.045 | ± 0.12 |
| o-Ethylphenol | 99.5 | 9503886, 9486643, 9526113 | 0.21 | ± 0.90 |
| o-Ethylphenol | 5.06 | 370356, 371026, 370833 | 0.093 | ± 0.40 |

C-II. ESTIMATION OF ACCURACY OF RATE COEFFICIENTS

As discussed in Section B.2 and C.2 of Chapter V, the rate of disappearance of dodecane and o-ethylphenol is best represented by a first order rate equation:

$$\ln \frac{C}{C_0} = -kt$$

where C and C_0 are instant and initial concentrations, respectively, t is the reaction time, and k the first order rate coefficient.

From a set of experimental C versus t data for each run, the k value is determined by curve-fitting. Through transformation of variables, the above nonlinear relation becomes a straight line

$$Y = \alpha + kx + \varepsilon$$

where $Y = \ln C/C_0$, $x = t - t_{av}$ and ε is a random variable drawn from $N(0, \sigma_{y,x}^2)$, the deviation from the line which is normally distributed with means 0 and constant variance $\sigma_{y,x}^2$.

Let the equation of the sample regression be written

$$\hat{Y} = a + \kappa x$$

where \hat{Y} is the estimated value, and a and κ are least square estimates of α and k . We can think of the sample regression coefficient κ as an

estimate of the rate constant k . Since κ can be written $\sum x_i Y_i / \sum x_i^2$, the relation between k and κ is

$$\kappa = \frac{\sum x_i (\alpha + kx_i + \epsilon_i)}{\sum x_i^2} = k + \frac{\sum x_i \epsilon_i}{\sum x_i^2}$$

The variance of κ as an estimate of k is

$$V(\kappa) = \sigma_{y,x}^2 / \sum x_i^2$$

and an unbiased sample estimate of $\sigma_{y,x}^2$ is

$$s_{y,x}^2 = \sum d_{y,x}^2 / (n-2)$$

where $y = Y - \bar{Y}$, $d_{y,x} = Y - \bar{Y} - \kappa x$, \bar{Y} is the mean of Y and n is the number of points used in fitting the line.

The sample estimate of the standard error of κ is

$$s_k = s_{y,x} / \sum x_i^2$$

The 95% confidence limits for k are

$$\kappa \pm t_{0.05} s_k$$

For example, while determining first order rate coefficient for dodecane thermolysis at 623 K, 9.2 MPa, N_2 (mixed data of Runs 7 and 12, cf. Table XLV in Appendix D), we have

$$k = 4.7 \times 10^{-7} \text{ s}^{-1}; s_k = 1.6 \times 10^{-7} \text{ s}^{-1}$$

$$n = 26 \quad t_{24;0.05} = 2.064$$

therefore, at a confidence level of 95%

$$k = 4.7 \times 10^{-7} \pm 3.3 \times 10^{-7} \text{ s}^{-1}$$

This is equivalent to a deviation of 34.6% in the k values. If we take the k values obtained by processing the data of Run 7 and 12 separately

$$k_7 = 4.5 \times 10^{-7}; k_{12} = 5.2 \times 10^{-7} \text{ s}^{-1}$$

the sample deviation is $\pm 10\%$. Hence, we can say that the k value presented for this condition is accurate to within $\pm (10-34.6)\%$.

Thermolysis of o-ethylphenol in dodecane was duplicated at conditions 623 K, 9.2 MPa N_2 - Runs 3 and 6, with $k_3 = 4.8 \times 10^{-6} \text{ s}^{-1}$ and $k_6 = 3.5 \times 10^{-6} \text{ s}^{-1}$. Regression of the mixed data from these two runs gives $k_m = 4.2 \times 10^{-6} \text{ s}^{-1}$, with $s_k = 9.8 \times 10^{-7} \text{ s}^{-1}$ and $t_{32;0.05} = 2.04$. Therefore $k = (4.2 \pm 2.0) \times 10^{-6} \text{ s}^{-1}$ with a sample standard deviation of $\pm 23.6\%$. The deviation estimated from k_3 and k_6 directly is $\pm 22.6\%$. We feel confident to say that k values reported for o-ethylphenol thermolysis in dodecane are accurate to within $\pm 24\%$.

APPENDIX D

TABULATION OF CALCULATED DATA

TABLE XLV
REGRESSION ANALYSIS OF DODECANE CONVERSION DATA

| Reaction Order n | Rate Coefficient k (s ⁻¹) | Correlation Coef. r | Resid. Mean Square s _{y,x} ² | t value |
|---|--|------------------------|---|---------|
| Run 7 (623 K, 9.2 MPa N ₂) | | | | |
| 0.4 | 7.1 x 10 ⁻⁶ | 0.9893 | 3.35 x 10 ⁻² | 1.419 |
| 0.6 | 2.8 x 10 ⁻⁶ | 0.9894 | 5.32 x 10 ⁻³ | 1.420 |
| 0.8 | 1.1 x 10 ⁻⁶ | 0.9894 | 8.45 x 10 ⁻⁴ | 1.422 |
| 1.0 | 4.5 x 10 ⁻⁷ | 0.9895 | 5.78 x 10 ⁻⁵ | 2.167 |
| 1.2 | 1.8 x 10 ⁻⁷ | 0.9895 | 8.23 x 10 ⁻⁵ | 0.7247 |
| 1.4 | 7.2 x 10 ⁻⁸ | 0.9896 | 9.34 x 10 ⁻⁵ | 0.2713 |
| 1.6 | 2.9 x 10 ⁻⁸ | 0.9896 | 9.81 x 10 ⁻⁵ | 0.1056 |
| 1.8 | 1.1 x 10 ⁻⁸ | 0.9897 | 1.00 x 10 ⁻⁴ | 0.04172 |
| 2.0 | 4.6 x 10 ⁻⁹ | 0.9898 | 1.01 x 10 ⁻⁴ | 0.01658 |
| Run 12 (623 K, 9.2 MPa N ₂) | | | | |
| 0.4 | 8.1 x 10 ⁻⁶ | 0.9916 | 2.85 x 10 ⁻² | 1.331 |
| 0.6 | 3.2 x 10 ⁻⁶ | 0.9917 | 4.52 x 10 ⁻³ | 1.332 |
| 0.8 | 1.3 x 10 ⁻⁶ | 0.9917 | 7.17 x 10 ⁻⁴ | 1.333 |
| 1.0 | 5.2 x 10 ⁻⁷ | 0.9918 | 4.73 x 10 ⁻⁵ | 2.070 |
| 1.2 | 2.1 x 10 ⁻⁷ | 0.9918 | 7.22 x 10 ⁻⁵ | 0.6684 |
| 1.4 | 8.2 x 10 ⁻⁸ | 0.9918 | 8.37 x 10 ⁻⁵ | 0.2476 |
| 1.6 | 3.3 x 10 ⁻⁸ | 0.9919 | 8.86 x 10 ⁻⁵ | 0.09602 |
| 1.8 | 1.3 x 10 ⁻⁸ | 0.9919 | 9.05 x 10 ⁻⁵ | 0.03788 |
| 2.0 | 5.2 x 10 ⁻⁹ | 0.9920 | 9.13 x 10 ⁻⁵ | 0.01504 |

TABLE XLV (continued)

| Reaction Order n | Rate Coefficient k (s ⁻¹) | Correlation Coef. r | Resid. Mean Square $s_{y,x}^2$ | t value |
|---|--|------------------------|-----------------------------------|---------|
| Run 7 and 12 (mixed data) | | | | |
| 0.4 | 7.3 x 10 ⁻⁶ | 0.9885 | 2.99 x 10 ⁻² | 1.890 |
| 0.6 | 2.9 x 10 ⁻⁶ | 0.9886 | 4.76 x 10 ⁻³ | 1.891 |
| 0.8 | 1.2 x 10 ⁻⁶ | 0.9886 | 7.55 x 10 ⁻⁴ | 1.893 |
| 1.0 | 4.7 x 10 ⁻⁷ | 0.9887 | 5.20 x 10 ⁻⁵ | 2.877 |
| 1.2 | 1.9 x 10 ⁻⁷ | 0.9887 | 7.31 x 10 ⁻⁵ | 0.9681 |
| 1.4 | 7.4 x 10 ⁻⁸ | 0.9888 | 8.26 x 10 ⁻⁵ | 0.3632 |
| 1.6 | 3.0 x 10 ⁻⁸ | 0.9888 | 8.66 x 10 ⁻⁵ | 0.1415 |
| 2.0 | 4.7 x 10 ⁻⁹ | 0.9889 | 8.89 x 10 ⁻⁵ | 0.02222 |
| Run 13 (673 K, 9.2 MPa N ₂) | | | | |
| 0.4 | 3.3 x 10 ⁻⁴ | 0.9901 | 22.2 | 1.220 |
| 0.6 | 1.4 x 10 ⁻⁴ | 0.9887 | 3.76 | 1.228 |
| 0.8 | 5.6 x 10 ⁻⁵ | 0.9872 | 0.637 | 1.237 |
| 1.0 | 2.3 x 10 ⁻⁵ | 0.9855 | 0.0333 | 2.245 |
| 1.2 | 9.7 x 10 ⁻⁶ | 0.9837 | 0.0802 | 0.6003 |
| 1.4 | 4.0 x 10 ⁻⁶ | 0.9817 | 0.106 | 0.2165 |
| 1.6 | 1.7 x 10 ⁻⁶ | 0.9796 | 0.118 | 0.08522 |
| 1.8 | 7.0 x 10 ⁻⁷ | 0.9773 | 0.124 | 0.03466 |
| 2.0 | 2.9 x 10 ⁻⁷ | 0.9749 | 0.126 | 0.01428 |
| Run 14 (623 K, 9.2 MPa H ₂) | | | | |
| 0.4 | 6.0 x 10 ⁻⁶ | 0.9848 | 0.0172 | 1.242 |
| 0.6 | 2.4 x 10 ⁻⁶ | 0.9848 | 0.00273 | 1.243 |
| 0.8 | 9.5 x 10 ⁻⁷ | 0.9849 | 4.33 x 10 ⁻⁴ | 1.244 |
| 1.0 | 3.8 x 10 ⁻⁷ | 0.9849 | 2.77 x 10 ⁻⁵ | 1.962 |
| 1.2 | 1.5 x 10 ⁻⁷ | 0.9849 | 4.49 x 10 ⁻⁵ | 0.6139 |
| 1.4 | 6.0 x 10 ⁻⁸ | 0.9850 | 5.31 x 10 ⁻⁵ | 0.2251 |
| 1.6 | 2.4 x 10 ⁻⁸ | 0.9850 | 5.65 x 10 ⁻⁵ | 0.08696 |
| 1.8 | 9.6 x 10 ⁻⁹ | 0.9850 | 5.79 x 10 ⁻⁵ | 0.03424 |
| 2.0 | 3.8 x 10 ⁻⁹ | 0.9851 | 5.85 x 10 ⁻⁵ | 0.01358 |

TABLE XLVI
TEST OF DIFFERENCE BETWEEN RUNS 12 AND 14

| Pair Number (Reaction time, 10^3 s) | Run 12 incremental conversion X_1 | Run 14 incremental conversion X_2 | Difference $D=X_1-X_2$ | Deviation $d=D-\bar{D}$ | Square Deviation d^2 |
|---|---|---|---------------------------|----------------------------|------------------------------|
| 1 (0.9) | 0.012 | 0.0002 | 0.0010 | 8.17×10^{-4} | 6.67×10^{-7} |
| 2 (2.76) | 0.0011* | 0.0012 | -0.0001 | -2.83×10^{-4} | 8.03×10^{-8} |
| 3 (4.8) | 0.0012* | 0.0013 | -0.0001 | -2.83×10^{-4} | 8.03×10^{-8} |
| 4 (5.4) | 0.0005 | 0.0003* | 0.0002 | 1.67×10^{-5} | 2.78×10^{-10} |
| 5 (7.2) | 0.0013 | 0.0010 | 0.0003 | 1.17×10^{-4} | 1.36×10^{-8} |
| 6 (9.0) | 0.0008 | 0.0005* | 0.0003 | 1.17×10^{-4} | 1.36×10^{-8} |
| 7 (9.6) | 0.0004* | 0.0002 | 0.0002 | 1.67×10^{-5} | 2.78×10^{-10} |
| 8 (10.8) | 0.0008 | 0.0005* | 0.0003 | 1.17×10^{-4} | 1.36×10^{-8} |
| 9 (12.0) | 0.0005* | 0.0006 | -0.0001 | -2.83×10^{-4} | 8.03×10^{-8} |
| 10 (12.6) | 0.0003 | 0.0002* | 0.0001 | -8.33×10^{-5} | 6.94×10^{-9} |
| 11 (14.4) | 0.0002 | 0.0006 | -0.0004 | -5.83×10^{-4} | 3.4×10^{-7} |
| 12 (16.2) | 0.0010 | 0.0002* | 0.0008 | 6.17×10^{-4} | 3.80×10^{-7} |
| 13 (16.8) | 0.0003* | 0.0001 | 0.0002 | 1.67×10^{-5} | 2.78×10^{-10} |
| 14 (18.0) | 0.0008 | 0.0003* | 0.0005 | 3.17×10^{-4} | 1.00×10^{-7} |
| 15 (19.2) | 0.0003* | 0.0003 | 0 | -1.83×10^{-4} | 3.36×10^{-8} |
| 16 (21.0) | 0.0005 | 0.0003* | 0.0002 | 1.67×10^{-5} | 2.78×10^{-10} |
| 17 (21.6) | 0.0003 | 0.0001 | 0.0002 | 1.67×10^{-5} | 2.78×10^{-10} |
| 18 (24.0) | 0.0013 | 0.0016 | -0.0003 | -4.83×10^{-4} | 2.34×10^{-7} |

Total 0.0128 0.0095 3.3×10^{-3} ~ 0 2.044×10^{-6}

Mean 7.11×10^{-4} 5.28×10^{-4} $\bar{D} = 1.83 \times 10^{-4}$ $s_{\bar{D}}^2 = 1.20 \times 10^{-7}$

$$s_{\bar{D}}^2 = 1.20 \times 10^{-7} / 18 = 6.68 \times 10^{-5} \quad s_{\bar{D}} = 8.17 \times 10^{-5}$$

$$t = \bar{D} / s_{\bar{D}} = 1.83 \times 10^{-4} / 8.17 \times 10^{-5} = 2.240 \quad \text{df,} = 16$$

$$P < 0.05$$

* By interpolation.

TABLE XLVII
REGRESSION ANALYSIS OF o-ETHYLPHENOL CONVERSION DATA

| Reaction Order n | Rate Coefficient k (s ⁻¹) | Correlation Coef. r | Resid. Mean Square s _{y,x} ² | t Value |
|---|--|------------------------|---|---------|
| Run 15 (623 K, 9.2 MPa N ₂) | | | | |
| 0.4 | 2.5 x 10 ⁻⁵ | 0.9375 | 0.162 | 1.648 |
| 0.6 | 9.9 x 10 ⁻⁶ | 0.9370 | 0.0259 | 1.650 |
| 0.8 | 5.6 x 10 ⁻⁶ | 0.9365 | 4.13 x 10 ⁻³ | 1.652 |
| 1.0 | 1.6 x 10 ⁻⁶ | 0.9360 | 2.14 x 10 ⁻⁴ | 2.904 |
| 1.2 | 6.3 x 10 ⁻⁷ | 0.9356 | 5.22 x 10 ⁻⁴ | 0.744 |
| 1.4 | 2.5 x 10 ⁻⁷ | 0.9351 | 6.96 x 10 ⁻⁴ | 0.258 |
| 1.6 | 1.0 x 10 ⁻⁷ | 0.9346 | 7.74 x 10 ⁻⁴ | 0.0977 |
| 1.8 | 4.0 x 10 ⁻⁸ | 0.9341 | 8.07 x 10 ⁻⁴ | 0.03831 |
| 2.0 | 1.6 x 10 ⁻⁸ | 0.9336 | 8.20 x 10 ⁻⁴ | 0.01520 |
| Run 16 (623 K, 9.2 MPa H ₂) | | | | |
| 0.4 | 2.5 x 10 ⁻⁵ | 0.9770 | 0.180 | 1.550 |
| 0.6 | 9.8 x 10 ⁻⁶ | 0.9767 | 0.0288 | 1.551 |
| 0.8 | 3.9 x 10 ⁻⁶ | 0.9765 | 4.59 x 10 ⁻³ | 1.554 |
| 1.0 | 1.6 x 10 ⁻⁶ | 0.9763 | 2.35 x 10 ⁻⁴ | 2.747 |
| 1.2 | 6.3 x 10 ⁻⁷ | 0.9761 | 5.73 x 10 ⁻⁴ | 0.7033 |
| 1.4 | 2.5 x 10 ⁻⁷ | 0.9758 | 7.54 x 10 ⁻⁴ | 0.2451 |
| 1.6 | 1.0 x 10 ⁻⁷ | 0.9756 | 8.34 x 10 ⁻⁴ | 0.09322 |
| 1.8 | 4.0 x 10 ⁻⁸ | 0.9754 | 8.67 x 10 ⁻⁴ | 0.03656 |
| 2.0 | 1.6 x 10 ⁻⁸ | 0.9752 | 8.81 x 10 ⁻⁴ | 0.01451 |
| Runs 15 and 16 (mixed data) | | | | |
| 0.4 | 2.5 x 10 ⁻⁵ | 0.9554 | 0.172 | 2.201 |
| 0.6 | 1.0 x 10 ⁻⁵ | 0.9550 | 2.75 x 10 ⁻² | 2.203 |
| 0.8 | 4.0 x 10 ⁻⁶ | 0.9547 | 4.38 x 10 ⁻³ | 2.207 |
| 1.0 | 1.6 x 10 ⁻⁶ | 0.9543 | 2.22 x 10 ⁻⁴ | 3.925 |
| 1.2 | 6.4 x 10 ⁻⁷ | 0.9540 | 5.56 x 10 ⁻⁴ | 0.9909 |
| 1.4 | 2.6 x 10 ⁻⁷ | 0.9536 | 7.41 x 10 ⁻⁴ | 0.3435 |
| 1.6 | 1.0 x 10 ⁻⁷ | 0.9532 | 8.23 x 10 ⁻⁴ | 0.1304 |
| 1.8 | 4.1 x 10 ⁻⁸ | 0.9529 | 8.57 x 10 ⁻⁴ | 0.05109 |
| 2.0 | 1.6 x 10 ⁻⁸ | 0.9525 | 8.71 x 10 ⁻⁴ | 0.02027 |

TABLE XLVIII
TEST OF DIFFERENCE BETWEEN RUNS 15 AND 16

| Pair Number (Reaction time, 10^3 s) | Run 12 incremental conversion X_1 | Run 14 incremental conversion X_2 | Difference $D=X_1-X_2$ | Deviation $d=D-\bar{D}$ | Square Deviation d^2 |
|---|---|---|---------------------------------|----------------------------|---|
| 1 (0.6) | 0.0010 | 0.0007* | -0.0003 | -5.88×10^{-4} | 3.45×10^{-7} |
| 2 (0.9) | 0.0001* | 0.0004 | 0.0003 | 1.18×10^{-5} | 1.38×10^{-10} |
| 3 (2.1) | 0.0005 | 0.0011* | 0.0006 | 3.12×10^{-4} | 9.72×10^{-8} |
| 4 (2.4) | 0.0003* | 0.0003 | 0 | -2.88×10^{-4} | 8.31×10^{-8} |
| 5 (3.6) | 0.0011 | 0.0011* | 0 | -2.88×10^{-4} | 8.31×10^{-8} |
| 6 (4.2) | 0.0009* | 0.0005 | -0.0004 | -6.88×10^{-4} | 4.74×10^{-7} |
| 7 (6.0) | 0.0027 | 0.0022 | -0.0005 | -7.88×10^{-4} | 6.21×10^{-7} |
| 8 (7.8) | 0.0017 | 0.0019* | 0.0002 | -8.83×10^{-5} | 7.79×10^{-9} |
| 9 (8.44) | 0.0001* | 0.0006 | 0.0005 | 2.12×10^{-4} | 4.48×10^{-8} |
| 10 (9.0) | 0.0002 | 0.0012* | 0.0010 | 7.12×10^{-4} | 5.07×10^{-7} |
| 11 (10.8) | 0.0008* | 0.0013 | 0.0005 | 2.12×10^{-4} | 4.48×10^{-8} |
| 12 (12.0) | 0.0008 | 0.0016* | 0.0008 | 5.12×10^{-4} | 2.62×10^{-7} |
| 13 (13.2) | 0.0019* | 0.0017 | -0.0002 | -4.88×10^{-4} | 2.38×10^{-7} |
| 14 (15.0) | 0.0028 | 0.0022* | -0.0006 | -8.88×10^{-4} | 7.89×10^{-7} |
| 15 (15.6) | 0.0011* | 0.0007 | -0.0004 | -6.88×10^{-4} | 4.74×10^{-7} |
| 16 (18.0) | 0.0044 | 0.0070 | 0.0026 | 2.32×10^{-3} | 5.34×10^{-6} |
| 17 (21.0) | 0.0080 | 0.0088 | 0.0008 | 5.12×10^{-4} | 2.62×10^{-7} |
| Total | 0.0284 | 0.0333 | 4.4×10^{-3} | ~ 0 | 9.67×10^{-6} |
| Mean | 1.67×10^{-3} | 1.96×10^{-3} | $\bar{D} = 2.88 \times 10^{-4}$ | | $s_D^2 = 6.05 \times 10^{-7}$ |
| | | | | | $s_{\bar{D}}^2 = 6.05 \times 10^{-7} / 17 = 3.56 \times 10^{-8}$ |
| | | | | | $s_{\bar{D}} = 1.89 \times 10^{-4}$ |
| | | | | | $t = \bar{D} / s_{\bar{D}} = 2.88 \times 10^{-4} / 1.89 \times 10^{-4} = 1.524$ df = 15 |
| | | | | | P \approx 0.16 |

* by interpolation.

TABLE XLIX
REGRESSION ANALYSIS OF o-ETHYLPHENOL IN DODECANE CONVERSION DATA

| Reaction Order n | Rate Coefficient k (s ⁻¹) | Correlation Coef. r | Resid. Mean Square s _{y,x} ² | t value |
|--|--|------------------------|---|---------|
| Run 3 (623 K, 9.2 MPa N ₂) | | | | |
| 0.4 | 1.2 x 10 ⁻⁵ | 0.9723 | 3.89 x 10 ⁻¹ | 0.8993 |
| 0.6 | 8.7 x 10 ⁻⁶ | 0.9727 | 2.04 x 10 ⁻¹ | 0.9235 |
| 0.8 | 6.5 x 10 ⁻⁶ | 0.9731 | 1.05 x 10 ⁻¹ | 0.9579 |
| 1.0 | 4.8 x 10 ⁻⁶ | 0.9735 | 5.58 x 10 ⁻³ | 3.0894 |
| 1.2 | 3.6 x 10 ⁻⁶ | 0.9738 | 1.54 x 10 ⁻² | 1.3843 |
| 1.4 | 2.7 x 10 ⁻⁶ | 0.9742 | 2.59 x 10 ⁻² | 0.7925 |
| 1.6 | 2.0 x 10 ⁻⁶ | 0.9745 | 3.56 x 10 ⁻² | 0.5029 |
| 1.8 | 1.5 x 10 ⁻⁶ | 0.9748 | 4.39 x 10 ⁻² | 0.3318 |
| 2.0 | 1.1 x 10 ⁻⁶ | 0.9750 | 5.06 x 10 ⁻² | 0.2336 |
| Run 6 (623 K, 9.2 MPa N ₂) | | | | |
| 0.4 | 9.5 x 10 ⁻⁶ | 0.9779 | 2.60 x 10 ⁻¹ | 0.9474 |
| 0.6 | 6.9 x 10 ⁻⁶ | 0.9777 | 1.29 x 10 ⁻¹ | 0.9689 |
| 0.8 | 5.0 x 10 ⁻⁶ | 0.9775 | 6.29 x 10 ⁻² | 0.9997 |
| 1.0 | 3.6 x 10 ⁻⁶ | 0.9772 | 3.60 x 10 ⁻³ | 3.0127 |
| 1.2 | 2.6 x 10 ⁻⁶ | 0.9769 | 9.46 x 10 ⁻³ | 1.3390 |
| 1.4 | 1.9 x 10 ⁻⁶ | 0.9766 | 1.55 x 10 ⁻² | 0.7547 |
| 1.6 | 1.3 x 10 ⁻⁶ | 0.9763 | 2.07 x 10 ⁻² | 0.9763 |
| 2.0 | 6.9 x 10 ⁻⁶ | 0.9756 | 2.84 x 10 ⁻² | 0.2087 |
| Runs 3 and 6 (mixed data) | | | | |
| 0.4 | 1.1 x 10 ⁻⁵ | 0.9474 | 3.23 x 10 ⁻¹ | 1.3140 |
| 0.6 | 7.9 x 10 ⁻⁶ | 0.9472 | 1.60 x 10 ⁻¹ | 1.3440 |
| 0.8 | 5.7 x 10 ⁻⁶ | 0.9469 | 7.86 x 10 ⁻² | 1.3872 |
| 1.0 | 4.1 x 10 ⁻⁶ | 0.9466 | 4.52 x 10 ⁻³ | 4.1753 |
| 1.2 | 3.0 x 10 ⁻⁶ | 0.9462 | 1.18 x 10 ⁻² | 1.8653 |
| 1.4 | 2.1 x 10 ⁻⁶ | 0.9459 | 1.94 x 10 ⁻² | 1.0514 |
| 1.6 | 1.5 x 10 ⁻⁶ | 0.9455 | 2.60 x 10 ⁻² | 0.6547 |
| 2.0 | 8.1 x 10 ⁻⁶ | 0.9447 | 3.58 x 10 ⁻² | 0.2913 |

VITA ²

Peizheng Zhou

Candidate for the Degree of

Doctor of Philosophy

Thesis: KINETIC STUDY OF THERMOLYTIC REACTIONS OF ETHYLPHENOLS
AND SOLVENT DODECANE

Major Field: Chemical Engineering

Biographical:

Personal Data: Born in Shanghai, China, October 1, 1932, the son of Lunfang Y. L. and Wenyu S. Zhou. Married to Shining Dong, Shanghai, China.

Education: Graduated from St. Francis Xavier's College, Shanghai, China, in August, 1951; received Diploma in Chemical Engineering from Peking Petroleum Institute in August, 1955; received Diploma in Petroleum Refining Engineering from the Graduate College of Peking Petroleum Institute in August 1959; completed requirements for the Doctor of Philosophy degree at Oklahoma State University in December, 1984.

Professional Experience: Assistant Teacher and Assistant Professor, September, 1959 to November, 1969; Department of Petroleum Refining Engineering, Peking Petroleum Institute; Lecturer, December, 1969 to August, 1980, Department of Petroleum Refining Engineering, East China Petroleum Institute.