

THE EFFECT OF WEB CHARACTERISTICS
ON WOUND-ON-TENSION IN WINDING

By

MANDAR MARFATIA

Bachelor of Engineering

Vishwakarma Institute of Technology

Pune University

Pune, India

1995

Submitted to the Faculty of the
Graduate College of the
Oklahoma State University
in partial fulfillment of
the requirements for
the Degree of
MASTER OF SCIENCE
May, 1999

THE EFFECT OF WEB CHARACTERISTICS
ON WOUND-ON-TENSION IN WINDING

Thesis Approved:



Thesis Adviser

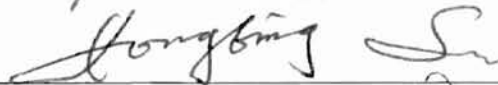

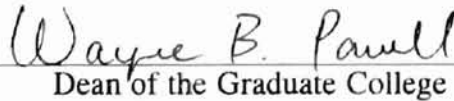

Dean of the Graduate College

ACKNOWLEDGEMENT

I wish to thank my Graduate Advisor, Dr. J. K. Good for his invaluable guidance, supervision and moral support during the courses of this research. I would also like to thank my other committee members Dr. C. E. Price and Dr. H. Lu for their guidance, assistance and continuous encouragement.

I owe special thanks to Mr. Ron Markum and Mr. Jerry Dale for providing an excellent technical support during the tough phases of this research. My gratitude towards all my friends who directly or indirectly contributed towards this research.

Additionally, I would like to thank the sponsors of the Web Handling Research Center (WHRC) for supporting this research. I would like to thank the School of Mechanical and Aerospace Engineering at Oklahoma State University for providing a magnificent learning experience.

However, my deepest gratitude is as always given to my parents and my family members for their continuous encouragement for my educational endeavors.

TABLE OF CONTENTS

Chapter	Page
I. INTRODUCTION	1
II. LITERATURE SURVEY	4
2.1 Center Winding	4
2.2 Surface Winding	6
2.3 Objective of Research	12
2.4 Potential	12
III. EXPERIMENTAL SET-UP	13
3.1 Description of the set-up	13
3.1.1 Unwind Station	13
3.1.2 FIFE Guide	13
3.1.3 Nip Roller	13
3.1.4 Angle of Wrap Adjustment Roller	14
3.1.5 Nip Load	14
3.1.6 Winding Station	14
3.2 Data Acquisition	16
3.3 Measurements of Winding Parameters	16
3.3.1 Web-Line Tension	16
3.3.2 Web-Line Speed	16
3.3.3 Nip Load	18
3.3.4 Wound-On-Tension	18
3.4 Winding Procedure	18
3.4.1 Winding Path	18
3.4.2 Input Parameters	19

3.4.3 Combinations	19
3.5 Web Materials	20
IV. RESULTS AND DISCUSSION	21
4.1 WOT and NIT Vs. Nip Load	22
4.2 WOT Vs. Nip Load (Superimposed with Nip Roller Diameters)	32
4.3 WOT and NIT Vs. Nip Roller Diameter	35
4.4 NIT vs. Nip Load (Confidence Level)	38
4.5 Surface Roughness of Nip Rollers	40
4.6 Coefficient of Friction between Web and Nip Roller Surface	41
4.7 Discussion	43
V. CONCLUSIONS	45
VI. FUTURE SCOPE	48
REFERENCES	49
APPENDIX	51

LIST OF TABLES

Table		Page
3.1	Web Material Properties	20
4.1	Tolerance on the measured winding parameters	21
4.2	Values of Kinetic Friction between Paper web materials and Aluminum rollers for 90 degrees wrap angle	42
4.3	Slope of WOT vs. Nip Load Plots	44
A-1	Experimental results for Center Winding of HWC paper	52
A-2	Experimental results for Center Winding of LWC paper	53
A-3	Experimental results for Center Winding of UCB paper	54
A-4	Experimental results for Center Winding of ICI polyester film	55
A-5	Experimental results for Center Winding of MOBIL polypropylene film	56

LIST OF FIGURES

Figure	Page
2.1 Center winding with undriven nip	5
2.2 Surface Winding	5
2.3 Experimental Set-up used by Pfeiffer [3] for measurement of Wound-In-Tension	8
2.4 Experimental set up used by Good and Wu [5]	10
2.5 Experimental set up used by Prabhakar [6]	11
3.1 Experimental Set-Up	15
3.2 Photograph of Experimental Set-up taken at Web Handling Research Center, OSU	17
4.1(a) WOT and NIT Vs. Nip Load for Heavy Weight Coated Paper, for 2.5" Diameter Nip Roller	22
4.1(b) WOT and NIT Vs. Nip Load for Heavy Weight Coated Paper, for 6" Diameter Nip Roller	23
4.1(c) WOT and NIT Vs. Nip Load for Heavy Weight Coated Paper, for 8" Diameter Nip Roller	23
4.2(a) WOT and NIT Vs. Nip Load for Light Weight Coated Paper, for 2.5" Diameter Nip Roller	24
4.2(b) WOT and NIT Vs. Nip Load for Light Weight Coated Paper, for 6" Diameter Nip Roller	24
4.2(c) WOT and NIT Vs. Nip Load for Light Weight Coated Paper, for 8" Diameter Nip Roller	25
4.3(a) WOT and NIT Vs. Nip Load for Uncoated Bond Paper, for 2.5" Diameter Nip Roller	26
4.3(b) WOT and NIT Vs. Nip Load for Uncoated Bond Paper, for 6" Diameter Nip Roller	26
4.3(c) WOT and NIT Vs. Nip Load for Uncoated Bond Paper, for 8" Diameter Nip Roller	27

Figure	Page
4.4(a) WOT and NIT vs. Nip Load for ICI Polyester film, for 2.5" Diameter Nip Roller	28
4.4(b) WOT and NIT vs. Nip Load for ICI Polyester film, for 6" Diameter Nip Roller	28
4.4(c) WOT and NIT vs. Nip Load for ICI Polyester film, for 8" Diameter Nip Roller	29
4.5(a) WOT and NIT vs. Nip Load for MOBIL Polypropylene film, for 2.5" Diameter Nip Roller	30
4.5(b) WOT and NIT vs. Nip Load for MOBIL Polypropylene film, for 6" Diameter Nip Roller	30
4.5(c) WOT and NIT vs. Nip Load for MOBIL Polypropylene film, for 8" Diameter Nip Roller	31
4.6 WOT Vs. Nip Load Diameter for Heavy Weight Coated Paper, for various Nip Roller Diameters	32
4.7 WOT Vs. Nip Load Diameter for Light Weight Coated Paper, for various Nip Roller Diameters	33
4.8 WOT Vs. Nip Load Diameter for Uncoated Bond Paper, for various Nip Roller Diameters	33
4.9 WOT Vs. Nip Load Diameter for ICI Polyethylene film, for various Nip Roller Diameters	34
4.10 WOT Vs. Nip Load Diameter for MOBIL Polypropylene film, for various Nip Roller Diameters	34
4.11 WOT Vs. Nip Roller Diameter for Heavy Weight Coated Paper, for various Nip Loads	35
4.12 WOT Vs. Nip Roller Diameter for Light Weight Coated Paper, for various Nip Loads	36
4.13 WOT Vs. Nip Roller Diameter for Uncoated Bond Paper, for various Nip Loads	36
4.14 WOT Vs. Nip Roller Diameter for ICI Polyester film, for various Nip Loads	37
4.15 WOT Vs. Nip Roller Diameter for MOBIL Polypropylene film, for various Nip Loads	37
4.16 95% Confidence level superimposed on Average NIT Vs Nip Load for HWC Paper, plotted for various Nip Roller Diameters	39
4.17 Surface roughness (Ra) along Nip Roller Length, plotted for various Nip Roller Diameters	40

Figure	Page
4.18 Schematic diagram of friction tests between nip roller and webs.	42
A-1 95% Confidence level superimposed on average NIT vs. Nip Load For LWC paper, plotted for various Nip Roller Diameters	57
A-2 95% Confidence level superimposed on average NIT vs. Nip Load For UCB paper, plotted for various Nip Roller Diameters	58
A-3 95% Confidence level superimposed on average NIT vs. Nip Load For ICI polyester film, plotted for various Nip Roller Diameters	59
A-4 95% Confidence level superimposed on average NIT vs. Nip Load For MOBIL polypropylene, plotted for various Nip Roller Diameters	60
A-5 Web-line speed vs. roll radius, plotted for HWC paper (2.5" diameter nip roll).	61
A-6 Web-line speed vs. roll radius, plotted for LWC paper (2.5" diameter nip roll).	61
A-7 Web-line tension vs. roll radius, plotted for HWC paper (2.5" diameter nip roll).	62
A-8 Web-line tension vs. roll radius, plotted for LWC paper (2.5" diameter nip roll).	62
A-9 Nip load vs. roll radius, plotted for HWC paper (2.5" diameter nip roll).	63
A-10 Nip load vs. roll radius, plotted for LWC paper (2.5" diameter nip roll).	63
A-11 Nip load vs. roll radius, plotted for UCB paper (2.5" diameter nip roll).	64
A-12 Nip load vs. roll radius, plotted for ICI polyester film (2.5" diameter nip roll).	64
A-13 WOT vs. roll radius, plotted for HWC paper (2.5" diameter nip roll).	65
A-14 WOT vs. roll radius, plotted for LWC paper (2.5" diameter nip roll).	65
A-15 WOT vs. roll radius, plotted for HWC paper (2.5" diameter nip roll).	66

NOMENCLATURE

WIT	Wound-In-Tension
WOT	Wound-On-Tension
pli	Pounds per linear inch
NIT	Nip-Induced-Tension
N	Nip Load
E	Modulus of Elasticity
E_t	Tangential Modulus of Elasticity
ksi	kilo-pounds per square inch
T_w	Web-Line-Tension
HWC	Heavy Weight Coated Paper
LWC	Light Weight Coated Paper
UCB	Uncoated Bond Paper
ICI	ICI Polyester film
MPP	MOBIL Polypropylene film
lbs.	Pounds
m_{st}	Static Coefficient of Friction
Ra	Average Surface Roughness

CHAPTER I

INTRODUCTION

A web is a thin, continuous, flexible strip of material such as paper, metal foil, plastic film or textiles that is stored in the form of wound rolls. Web materials are flexible and are, in most cases, assumed to be membranes, incapable of reacting to bending moments.

Web handling is a process of transporting webs from an unwind station to a rewind station where it may pass through intermediate processing operations such as coating or printing.

Winding is a process by which the web is wound on a rotating core into a roll. Winding is an integral operation which takes place in almost every web-handling process. During winding, several parameters including speed of web, web-line tension and wound on tension are measured, monitored and controlled. The purpose is to achieve a desired structure of a wound roll, which is to be made suitable for a particular application. Parameters mentioned above are discussed in detail later in the chapter.

Winding machines are composed of a series of rollers placed in a particular fashion in order to obtain a desired condition and structure of a wound roll. These rollers are generally made up of aluminum, steel, or polymers with their surface machined to get a desired coefficient of friction between roller and web. The web is made to pass over a series of such rollers. These rollers are generally mounted on frictionless bearing supports.

Web handling products are very important to consumers and has become an integral part of the life of every human being. The usage starts from a candy wrapper and extends up to magnetic tapes. From the industrial standpoint, web handling has always kept engineers busy by offering challenges to balance the demand and supply of the consumer market. With the growing needs of quantity as well as quality, researchers are forced to enhance the performance of existing winding methods to increase the speed of production and improve quality. This can be achieved by controlling the variables associated with winding that limit the performance. The thesis explores the effect of some of the web characteristics on winding variables, during center winding with an undriven rider roll.

When center winding with a rider roll, it is known that web tension, rider roll load (often called nip load), and rider roll diameter affect the wound-on-tension (WOT). It has been shown, as well, that at low nip loads the WOT increases in proportion to the nip load. However, at higher nip loads, it has been shown that the WOT may become nearly independent of nip load.

The purpose of this thesis is to investigate how web properties influence the WOT during center winding. The properties studied include the coefficient of friction (μ), the tangential modulus of the web (E_t) and caliper of the web.

Chapter two outlines studies done in the field on the effect of web characteristics in center winding. In this literature survey, analytical and experimental approaches towards formulation of wound-on-tension models are discussed.

Chapter three describes an experimental method adopted to establish the web characteristics for center winding. It, also, gives a detailed description of the measurement and control of various winding parameters during winding.

Results of the experiments are presented in chapter four. A database of the effect of various web characteristics on wound-on-tension is produced for reference.

Chapter five states the conclusions derived from the experiments. It describes how the derived database will help engineers to formulate better winding models for WOT.

Chapter six covers the Future Scope.

CHAPTER II

LITERATURE SURVEY

Much research has been done in the field of nip mechanics to study the effect of web characteristics on winding. Some of the works, carried out by Pfeiffer [1,2,3], Rand and Eriksson [4], Good and Wu [5], Prabhakar [6] and Good, Wu and Fikes [7], are mentioned in this chapter to give a brief idea of progress in the field and the need for further research. A description of the terms frequently used is presented first.

Two types of winding are most commonly used in web handling, Center Winding and Surface Winding.

2.1 Center Winding: In center winding, winding torque is applied to the core of the winding roll. A nip roll is impinged into the winding roll (Figure 2.1). The nip roller helps remove the trapped air between the wound-on layers and provides additional tension in the web during winding. Change in the wound-on-tension can be achieved by varying web line tension and load on the nip roller. When the web materials are non-permeable, air entrainment is not desired because it can result in poor quality of wound rolls. Hence, by using a nip roller, entrained air can be squeezed out. Application of center winding involves calendering. [8,9]

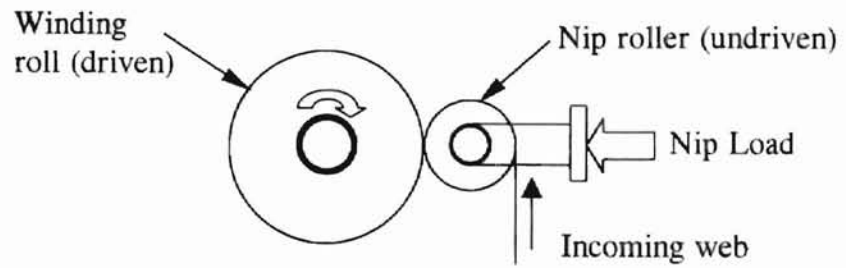

Figure 2.1: Center winding with undriven nip

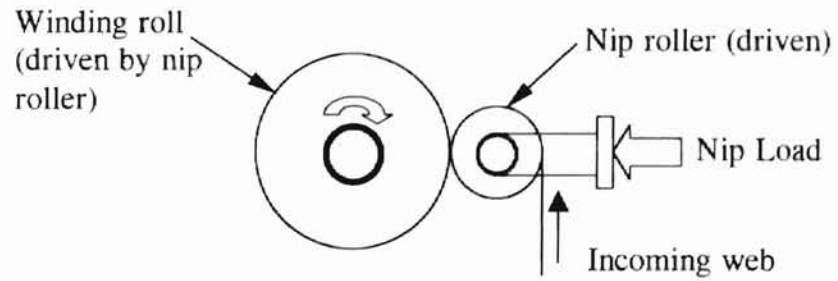

Figure 2.2 : Surface Winding

2.2 Surface winding: In surface winding, a driving torque is given to the nip roller, which transmits the winding torque to the winding roll by friction (Figure 2.2). Paper is most commonly wound using the surface winding method.

Studies done in the area of nip mechanics indicate that in center winding, nip induced tension is influenced by parameters such as nip load, nip roller diameter, winding roller diameter, and the coefficient of friction between web and surface of the rollers [1,2,3,4,5,6,7]. While conducting research on mechanics of a rolling nip on paper webs and internal pressures in a wound roll of paper, Pfeiffer [1,2] outlined how the nip force was responsible for increasing wound-in-tension (WIT, the tension induced in the wound layers of web) beyond the magnitude of web-line-tension in paper. However, Pfeiffer felt a need for further experimentation in the winding of actual rolls of different web materials.

Rand and Eriksson [4] designed and conducted experiments to study how nip, and in some cases multiple nips, impact WIT. They used small strain gage transducers imbedded within the paper webs and showed that as the web preceded around a wrapped cylindrical surface approaching the nip, the web tension dropped to a minimum just prior to the in-going side of the nip. They revealed that rolling nip elevated the tension on the outgoing side of the nip to a level higher than the minimum tension or the original web-carrying tension.

Pfeiffer [3] designed and built an experimental winder to measure the effect of nip force on kraft, newsprint and coated publication papers. Figure 2.3 is a schematic diagram of the arrangement he used by employing a special web wrap and load cell arrangement. This arrangement allowed the measurement of WIT; the tension in the web after it has passed under the nip roller. Pfeiffer noticed that WIT was 1.5 to 2.5 pli more than the web carrying tension (for a starting nip load of 20 pli). He observed that WIT continued to rise slowly under constant nip force with an increase of roll diameter. A web caliper effect was observed, which caused a slight rise in tension with an additive component that varied as an inverse proportion of roll diameter. Pfeiffer noticed a rise in system losses as the roll got heavier, causing a decrease in WIT which varied as inverse of square of roll diameter. Pfeiffer used a x-y recorder to plot the WIT vs. nip force curve and using these results, he derived a computer program to obtain a best curve fit equation. These equations were the first WOT models but since they were empirically derived were not generally applicable.

Good and Wu [5] presented results of analytical and experimental investigations which provided the first basic understanding of the nip-induced-tension (NIT, the tension induced in the wound layers of web solely due to the presence of a loaded nip) mechanism in center winding. Figure 2.4 shows a schematic of the experimental set up used by Good and Wu. The intent was to determine the source of mechanism of nip-induced-tension. It was observed that, for each nip diameter, the saturated value of total stress appeared to be linearly dependent upon nip loading. The experiments could explain not only why the NIT reached saturation but could reveal what mechanism caused it.

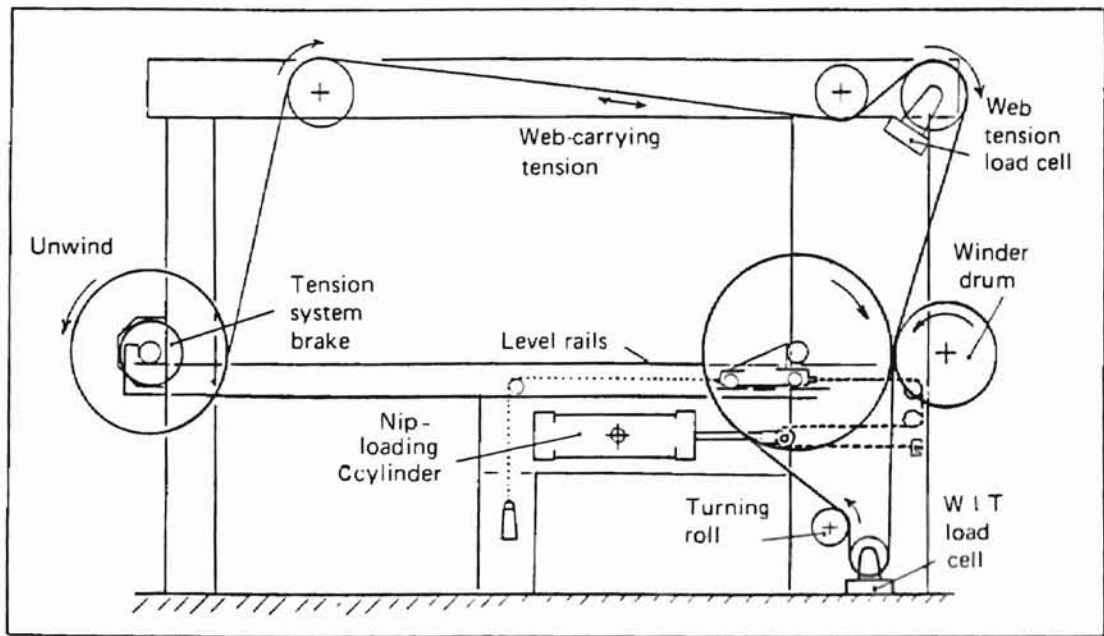

Figure 2.3: Experimental Set-up used by Pfeiffer [3] for measurement of WIT

Good and Wu [5] used finite element methods for further investigation. The problem of nip rolling over an elastic material was approximated as a Hertzian contact problem.

Based on all the experiments and finite element analysis, Good and Wu [5] concluded that the mechanism that was responsible for NIT in wound rolls, was an elongating machine direction strain which existed beneath the nip roll location on the lower side of the web, which was in intimate contact with the wound roll. The elongating strain was due to the compressive Hertzian-like contact stresses that existed through the depth of the web beneath the nip roller. As this elongating strain advances with the moving nip roll, web material attempts to advance in front of the nip and contract in towards the nip in back of the rolling nip. If web material in back of the nip were constrained, a net increase in web tension would have resulted due to the nip. The NIT could not exceed the kinetic coefficient between outer wrap and the wrap beneath it multiplied by the nip load.

Prabhakar [6] studied the effect of NIT on newsprint paper webs ($E=800$ ksi). Figure 2.5 shows a schematic diagram of the experimental set up used by Prabhakar. His analysis proved that the rate of nip-induced-stress depends on the nip diameter. The nip-induced-stress increases at a faster rate and saturates quickly for smaller diameter nips, as compared with larger diameter nips, with other winding parameters the same. It was concluded that the saturated value of nip-induced-stress depends on nip load and nip diameter, while the rate of nip-induced-stress depends on nip diameter.

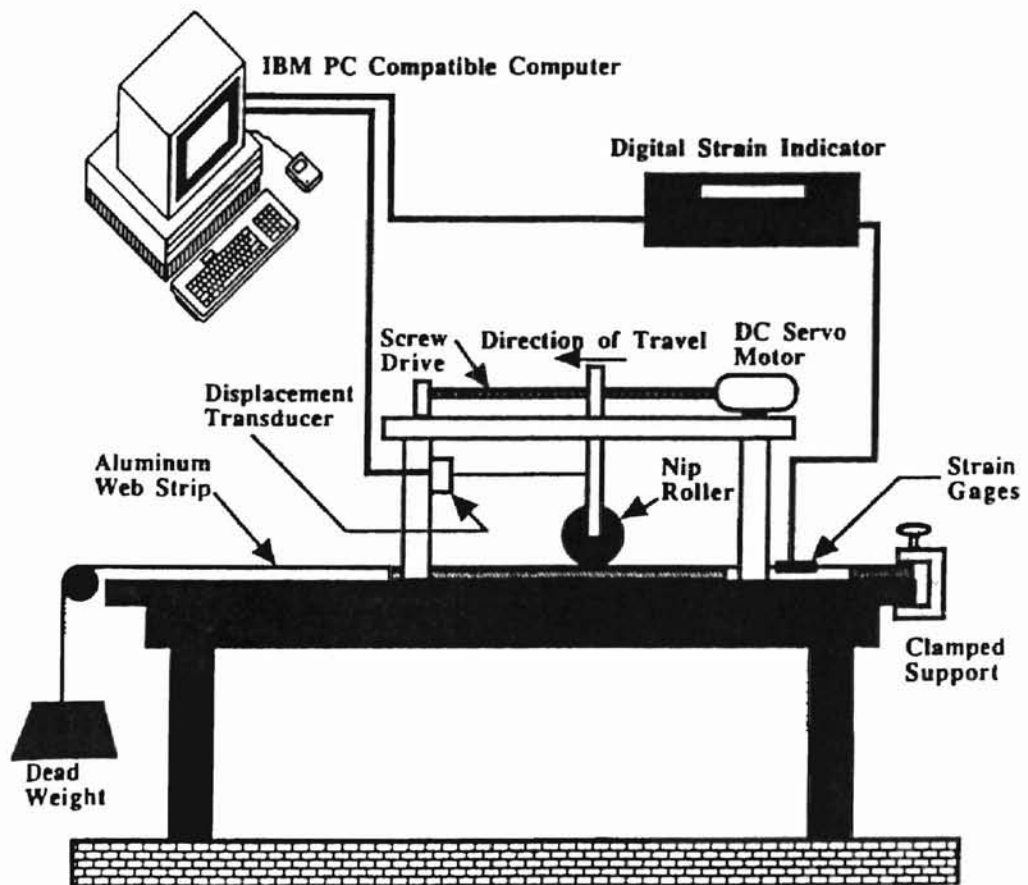
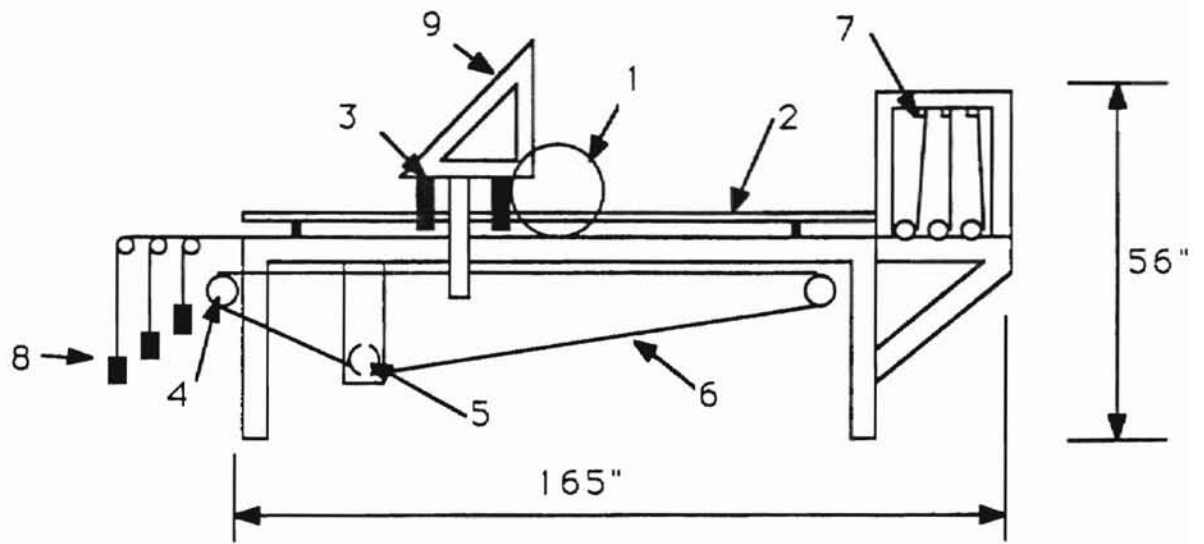

Figure 2.4 Experimental set up used by Good and Wu [5].



- | | |
|----------------------------|-----------------------------------|
| 1. Nip Roller | 6. Driving Belt |
| 2. Guide Rail | 7. Strain Gage |
| 3. Linear Bearing | 8. Dead Weights for Pre- tension |
| 4. Drive Motor | 9. Carriage for fixing Nip Roller |
| 5. Displacement Transducer | |

Figure 2.5 Experimental set up used by Prabhakar [6].

2.3 Research Objective:

The majority of the research has been done using newsprint paper, lightweight coated paper and Kraft paper. There is a need to know the effect of the web characteristics of other materials frequently used in the winding industry. The characteristics are web caliper, modulus of elasticity and coefficient of friction and winding parameters, such as web-line tension, nip roller diameter and nip load on wound-on-tension. A database of these variables is needed for various materials such as uncoated bond paper, lightweight coated bond paper, heavy weight coated bond paper, polyester and polypropylene.

2.4 Research Potential:

This study will establish a database that can serve as a ready reference to future model designers, by providing them with essential information on behavior of winding variables for different web materials in center winding. The experiments will give a graphical representation of the nature of WOT and NIT on different web materials.

CHAPTER III

EXPERIMENTAL SET-UP

3.1 Description of the set-up: The schematic of the set-up used for conducting winding experiments is shown in Figure 3.1. The following section describes various parts of the experimental set-up.

3.1.1 Unwind Station: This consisted of a shaft mounted on the vertical support plate, through low friction bearings. A pneumatic coupling was mounted over the shaft which secured the core of the unwind roll. (marked 1 in figure 3.1).

3.1.2 FIFE Guide: This was employed to prevent the lateral shift of the web, due to misalignment of rollers in the set-up or irregularity of wind on unwinding roll. It consisted of a sensor (marked 2b in figure 3.1) and an adjusting mechanism (marked 2a in figure 3.1). The sensor sensed the amount of lateral movement of web and the guide adjusting mechanism corrected the lateral web position.

3.1.3 Nip Roller: A nip roller (marked 3 in figure 3.1) was used to get a nip at the winding roll. The roller was not powered. Three different sizes of nip rollers were used for this research (2.5", 6" and 8").

3.1.4 Angle of Wrap Adjustment Roller: The roller (marked 4 in figure 3.1) was used to get a constant wrap angle over the nip roller. For a different size of nip roller diameter, a constant angle of wrap of 180° could be maintained by mounting the roller into appropriate slot. It is very important to maintain a constant wrap angle of 180° over nip roller in order to study the effect of nip-induced tension. A wrap angle of 180° helps to reduce the horizontal component of web-line tension to zero which otherwise would have offset the nip load.

3.1.5 Nip Load: A nip load was applied to the nip roller using a pneumatic cylinder (marked 5 in figure 3.1). The load cells mounted at each end of the nip roller monitored the magnitude of load applied by the cylinder. A Digital Tension Readout (DTR) was used to power the load cells and to read the output of the load cells. A LabVIEW routine was then used to read the signal from DTR and to compare it with the value entered by the user. Correspondingly, a signal would be sent to a relay, which was used to pressurize or drain the pneumatic cylinder if the nip load was low or high, respectively.

3.1.6 Winding Station: The winding station (marked 6 in figure 3.1) consisted of a shaft driven by an electric motor. The winding shaft could hold a steel core over which the web was wound. The speed of the winding shaft decreases during winding a roll to maintain a constant web speed. Web speed was maintained at 200 feet per min using a tach generator. The tach generator sensed the web speed and provided a feed back signal to the motor controller.

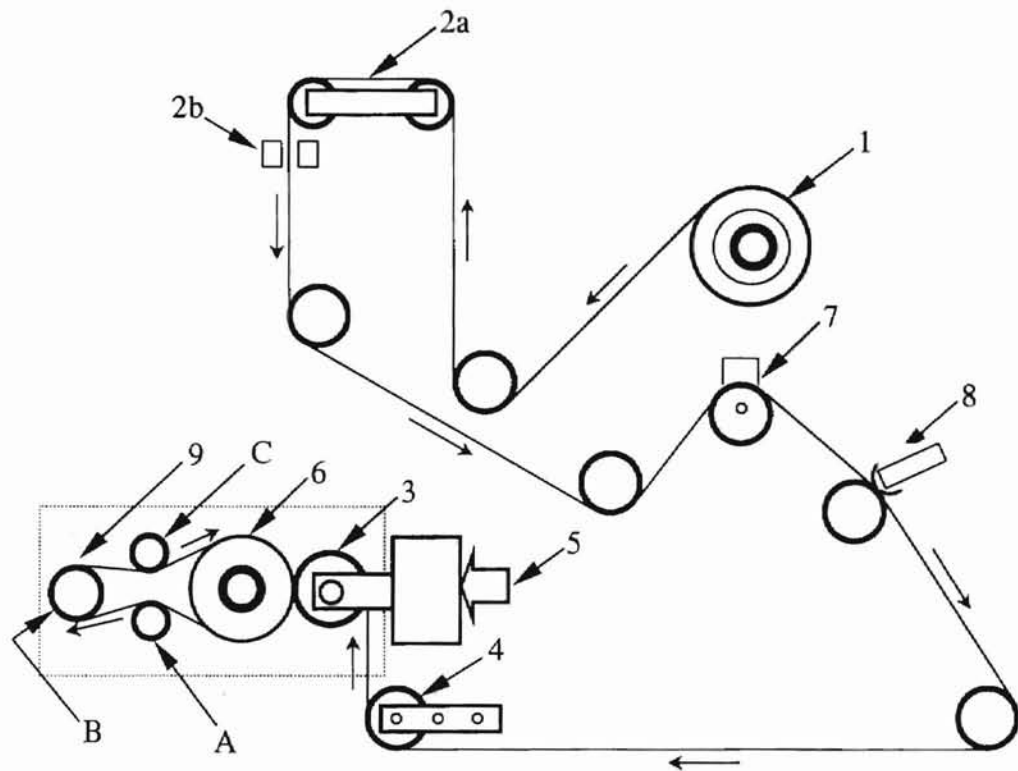

Legends:

- 1 Unwind Station: Application of web-line tension.
- 2 Web lateral motion guide
 - 2a. Sensor
 - 2b. Guide
- 3 Nip roller
- 4 Angle of wrap adjustment roller
- 5 Application of nip load
- 6 Winding Station: Winding roller
- 7 Web-Line-Tension measurement transducer
- 8 Web-line Speed measurement transducer
- 9 Wound-on-Tension measurement transducer

Figure 3.1: Schematic Diagram of the Experimental Set-Up

3.2 Data Acquisition: Each winding parameter was measured using a transducer and recorded by a PC using a data acquisition system. LabVIEW data acquisition software was used to design the logical sequence required for the control of each parameter. Recorded values were stored in a standard output text file that was used for plotting graphs and further analysis. Details of each parameter measurements and its acquisition are explained in the next article.

3.3 Measurements of Winding Parameters

3.3.1 Web-Line-Tension (T_w): Web-Line-Tension was applied by a magnetic hysteretic brake on the unwind shaft. The amount of tension required was entered by the user using a speed-torque controller board (marked A in figure 3.2). Measurement of web-line tension was accomplished using a load transducer at an idler roller (marked 7 in figure 3.1) and provided a feed back signal to the controller. This tension value was continuously recorded by the data acquisition system and was available in an output file.

3.3.2 Web-Line Speed: Power to drive the web-line came from the winder station (marked 6 in figure 3.1). The motor at the winding station governed web-line speed. To maintain a constant web-line speed, the effect of winding roll diameter had to be eliminated. This was achieved by continuously measuring web-line speed at the station marked 8 in figure 3.1. The measurement of the web-line speed is carried out as explained in section 3.1.6.

4.1.5. Nip Load Control: The nip load is controlled with the help of a pneumatic cylinder. The amount of nip load is controlled by the user via a LabVIEW software interface. Nip load

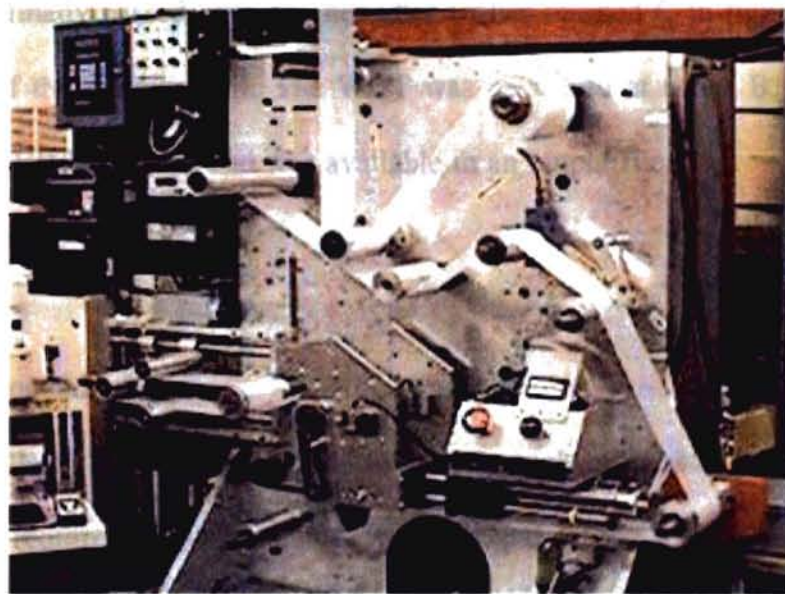

Figure 3.2 Photograph of Experimental Set-up
Taken at Web Handling Research Center, OSU.

3.3.3 Nip Load: The nip was loaded with the help of a pneumatic cylinder. The amount of desired nip load was entered by the user via a LabVIEW software interface. Nip load was measured using a method as explained in section 3.1.5. The software had a closed loop control that used a feedback signal of a measured value of nip load and compared it to the target value set by the user. Once the cycle started, the nip roller was loaded up to the desired nip load.

3.3.4 Wound-On-Tension: To measure the WOT, the web was extracted away from the surface of the winding roll after it had exited from the nip. It passed over an idler (roller marked A in figure 3.1), 180° around the idler mounted on a load cell (roller marked B in figure 3.1) and finally passed over another idler (roller marked C in figure 3.1) returning to the surface of the winding roll. The WOT was measured at roller B. This value was recorded by LabVIEW routine and was available in an output file.

3.4 Winding Procedure

3.4.1 Winding Path: The web was made to pass through a series of rollers (Figure 3.1) so that all the required measurement of winding parameters could be achieved. An unwind roll is mounted on the unwind station. The nature of the experiment was independent of the diameter of the unwind roll. However, the roll should have enough material to record readings for at least 5 minutes of winding time. This took care of the time that the web took to get into a steady state. The loose end of the roll was pulled by hand and made to pass over all the rolls as shown in figure 3.1. Its end was then taped to

the core on the winding shaft. The set up can be run, once the input parameters are fed into the software.

3.4.2 Input Parameters: A LabVIEW routine performed the data acquisition. This code carried the required circuit block diagrams and instructions that measured and controlled the winding parameters described in section 3.3. To run the experiment, data had to be fed into the code by the user. These values were web-line speed in feet per minute, nip load in pounds and desired web-line tension in pounds. Once all the parameters were set, the guide point was set to Auto Mode and the program was executed. When nip load reached the desired value, the motor was started and web-line tension was applied. The program started recording all the data and was terminated after all the web material was unwound from unwind shaft. The program then stored all data into an output file.

3.4.3 Combinations: A number of experiments were conducted to study the effect of WOT in center winding for different nip roller diameters, different nip loads and different web materials. Web materials include newsprint, uncoated bond paper (UCB), lightweight coated bond paper (LWC), heavy weight coated bond paper (HWC), ICI polyester and Mobil polypropylene (MPP). Different nip roller diameters were used including 2.5", 6" and 8" with nip loads varying from 15 lbs. to 120 lbs. Hence for each web material, data were collected for 3 different nip rollers and a series of nip loads.

3.5 Web Materials: Relevant properties of the web materials used are shown in Table 3.1.

	Web Materials	E_t (psi)	m_k	Thickness (in)
1	Heavy Weight Coated Paper (HWC)	1284000	0.45	0.0048
2	Light Weight Coated paper (LWC)	1098000	0.37	0.002
3	Uncoated Bond Paper (UCB)	1284000	0.4	0.0048
4	ICI Polyester (ICI_PE)	600000	0.28	0.002
5	Mobil Polypropylene (MPP)	270000	0.97	0.001

Table 3.1 Web Material Properties

CHAPTER IV

RESULTS AND DISCUSSION

The results plotted in this chapter are the mean of three winding trials. Confidence intervals of the data are presented. The web materials used in the experiments (Table 3.1) were 6 inches wide except for Mobil Polypropylene, which was 5 inches wide. A constant web-line tension of 1 pound per linear inch (pli) was applied. In all the graphs to follow, wound-on-tension (WOT) and nip-induced-tension (NIT) are mentioned in terms of pli. A web-line speed of 200 feet per minute was maintained for all the experiments.

Table 4.1 shows the tolerance levels with which the winding parameters were measured. These values are derived from the data acquisition plots shown in the Appendix. It can be observed from the appendix that WOT increases by 0.5 pli over a pile height of 2 inches for higher nip loads. In order to study the effect of WOT alone, an average value of WOT is used for plotting all the graphs.

Winding Parameters	Tolerance
Web-Line Speed	± 20 fpm
Web-Line Tension	± 0.2 lbs.
Nip Load	± 0.6 pli
WOT	± 0.2 pli

Table 4.1: Tolerance on the measured winding parameters.

4.1 WOT and NIT vs. Nip Load: WOT and NIT are plotted against various nip loads and three different nip roller diameters. Nip-induced tension was calculated based on the relation,

$$\text{WOT} = T_w + \text{NIT} \quad \dots (1)$$

where T_w is the web-line tension, which was kept constant ($T_w = 1 \text{ pli}$) throughout the experiments. Each graph represents a particular material as discussed in Table 3.1 and the graphs are shown in Figure 4.1 through 4.5. The trend-line shown in figures 4.1-4.4 indicates the low nip load region in which WOT increases linearly with nip load. Slopes are calculated based on this region of low nip load.

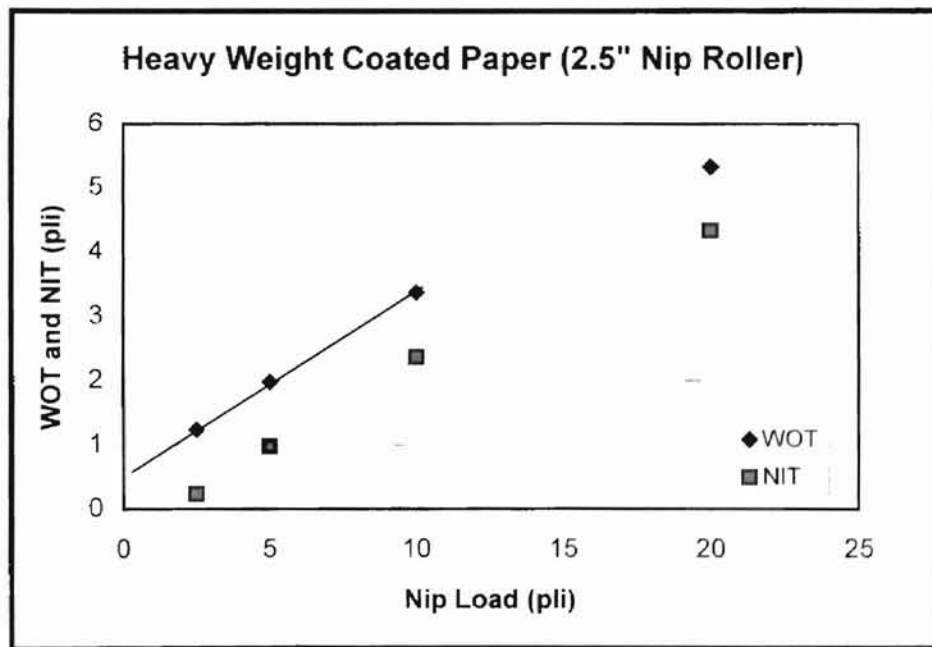

Figure 4.1 (a): WOT and NIT Vs. Nip Load for Heavy Weight Coated Paper, for 2.5" Diameter Nip Roller. (Slope=0.29)

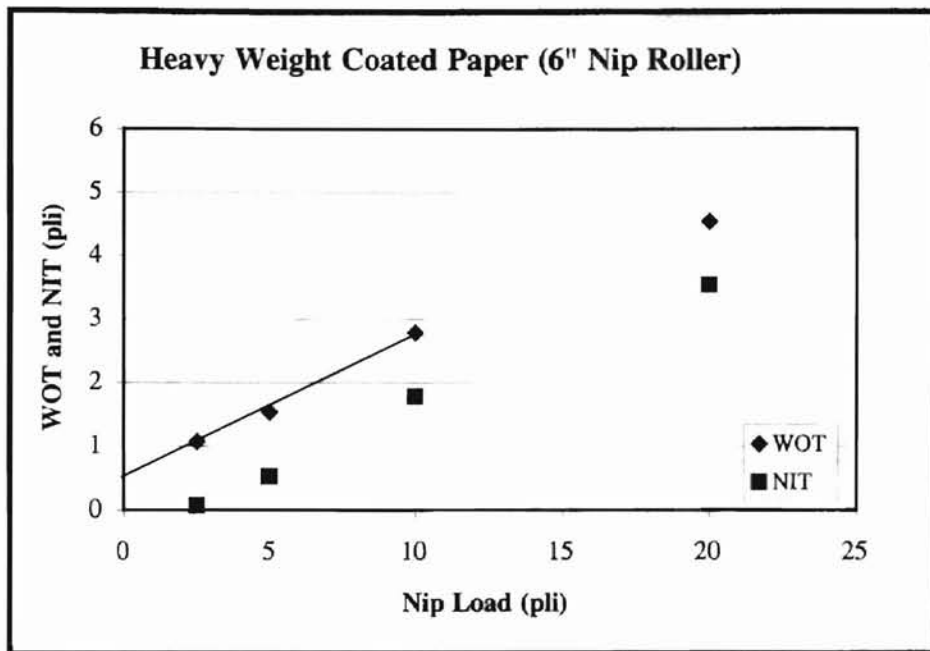

Figure 4.1 (b): WOT and NIT Vs. Nip Load for Heavy Weight Coated Paper, for 6" Diameter Nip Roller. (slope=0.22)

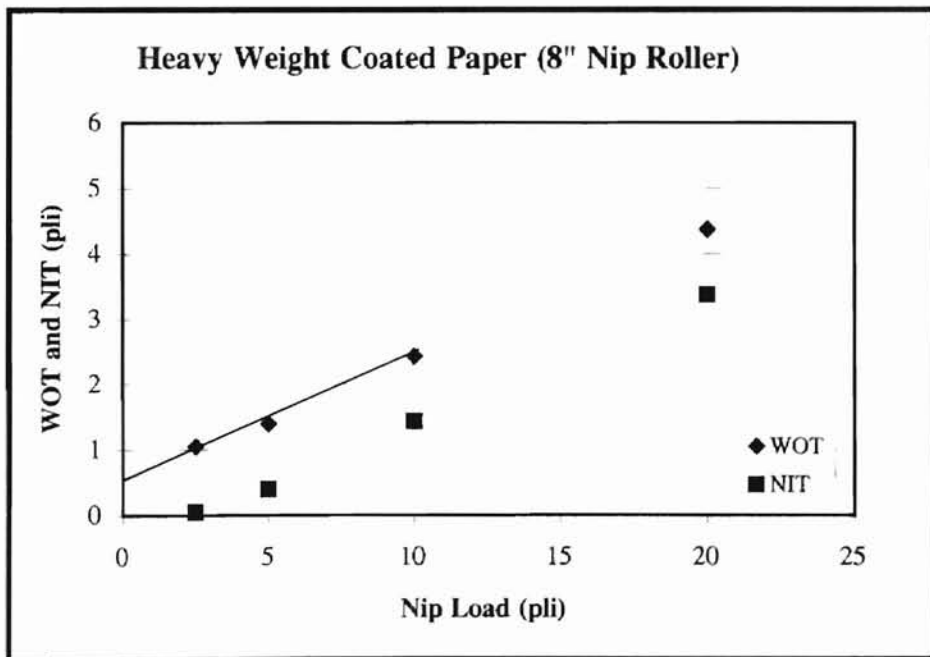

Figure 4.1 (c): WOT and NIT Vs. Nip Load for Heavy Weight Coated Paper, for 8" Diameter Nip Roller. (Slope=0.2)

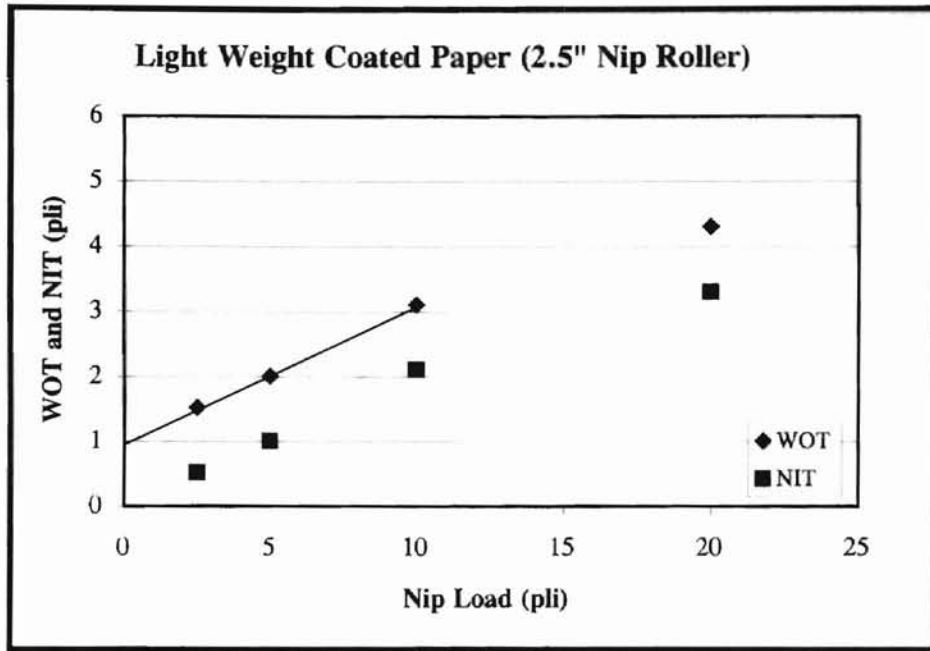

Figure 4.2 (a): WOT and NIT Vs. Nip Load for Light Weight Coated Paper, for 2.5" Diameter Nip Roller. (Slope=0.21)

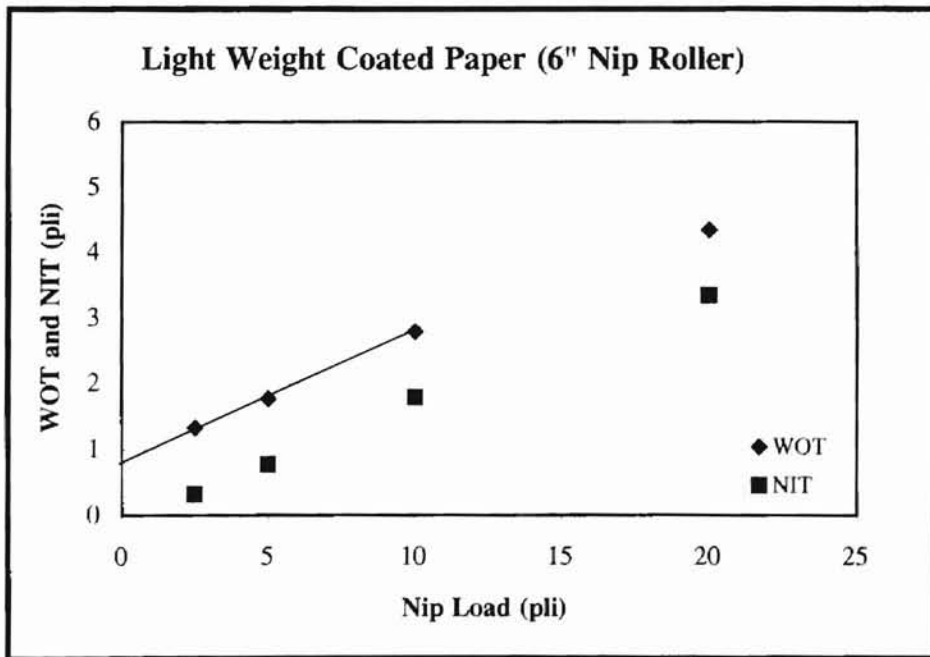

Figure 4.2 (b): WOT and NIT Vs. Nip Load for Light Weight Coated Paper, for 6" Diameter Nip Roller. (Slope=0.2)

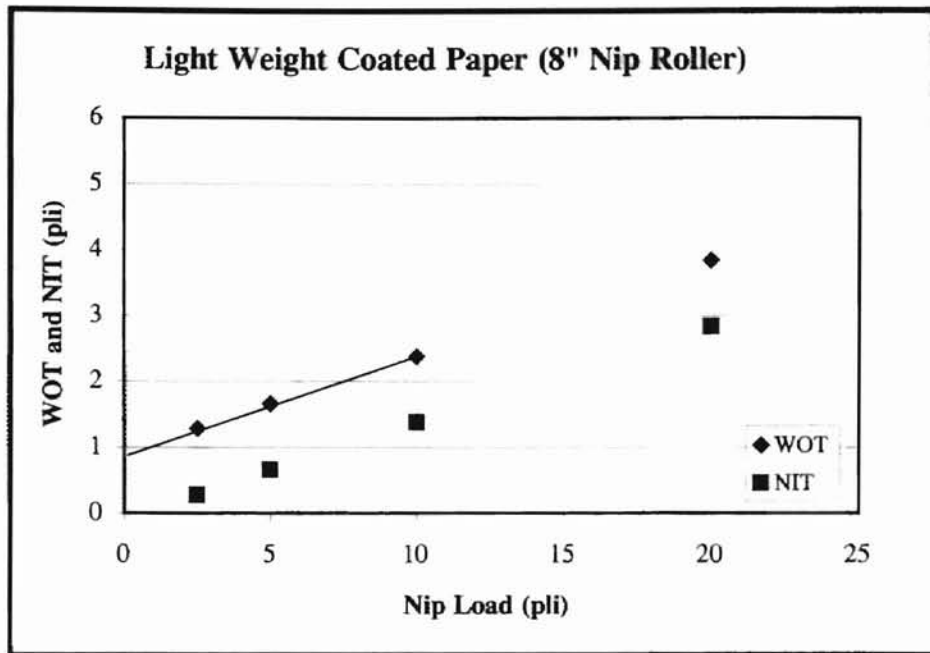

Figure 4.2 (c): WOT and NIT Vs. Nip Load for Light Weight Coated Paper, for 8" Diameter Nip Roller. (Slope=0.16)

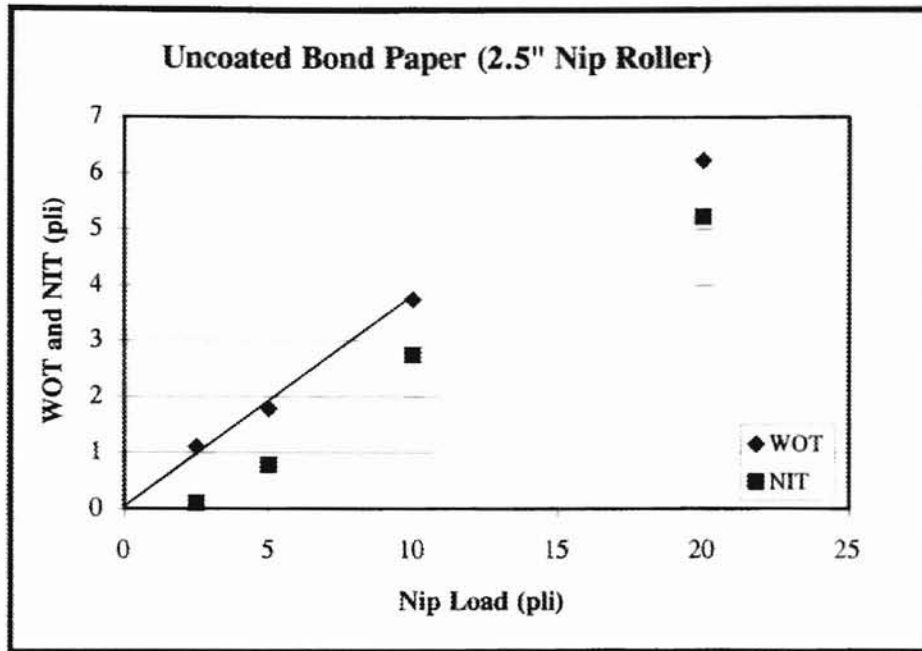

Figure 4.3 (a): WOT and NIT Vs. Nip Load for Uncoated Bond Paper, for 2.5" Diameter Nip Roller. (Slope=0.35)

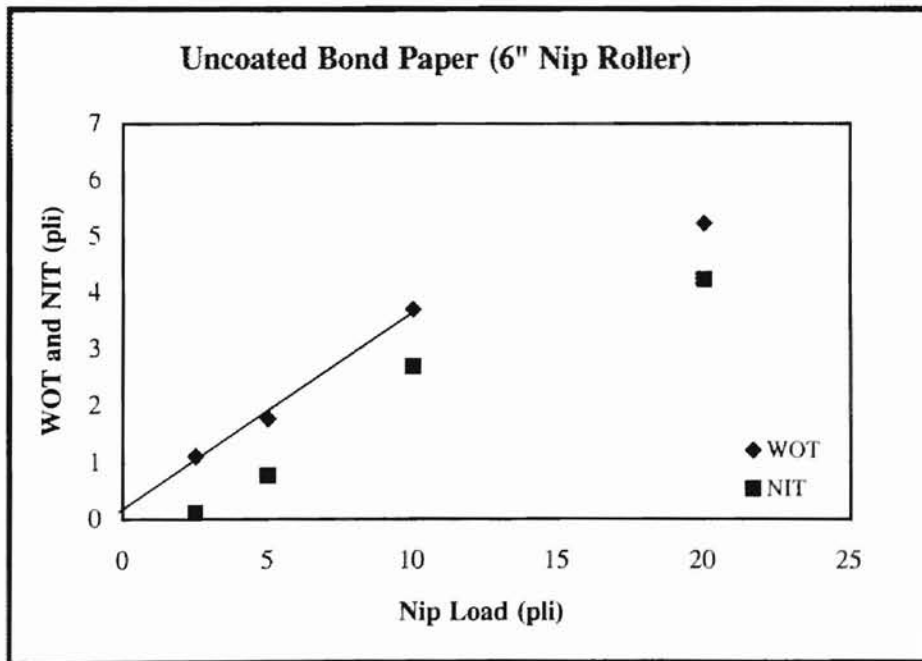

Figure 4.3 (b): WOT and NIT Vs. Nip Load for Uncoated Bond Paper, for 6" Diameter Nip Roller. (Slope=0.34)

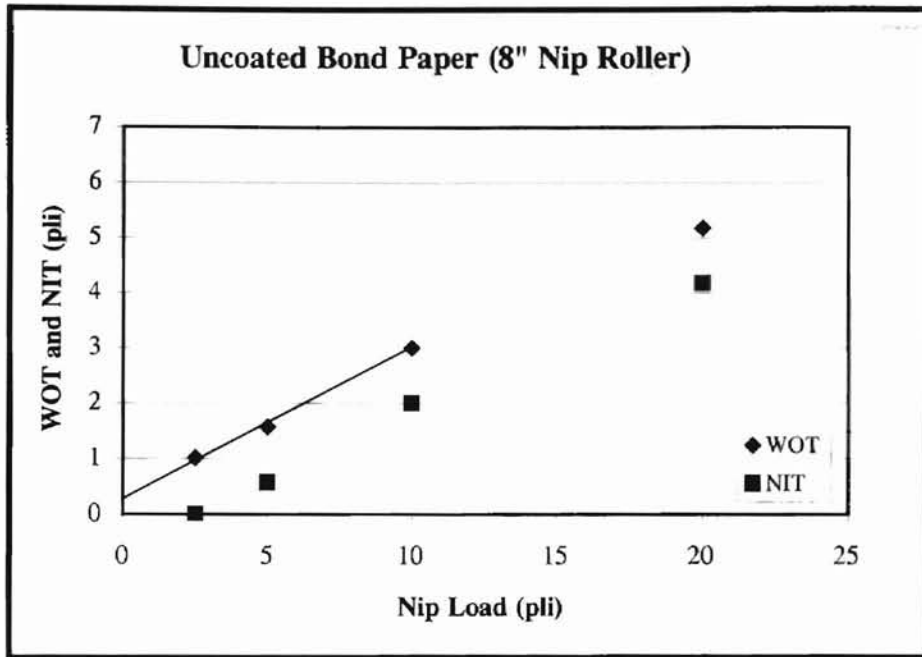

Figure 4.3 (c): WOT and NIT Vs. Nip Load for Uncoated Bond Paper, for 8" Diameter Nip Roller. (Slope=0.25)

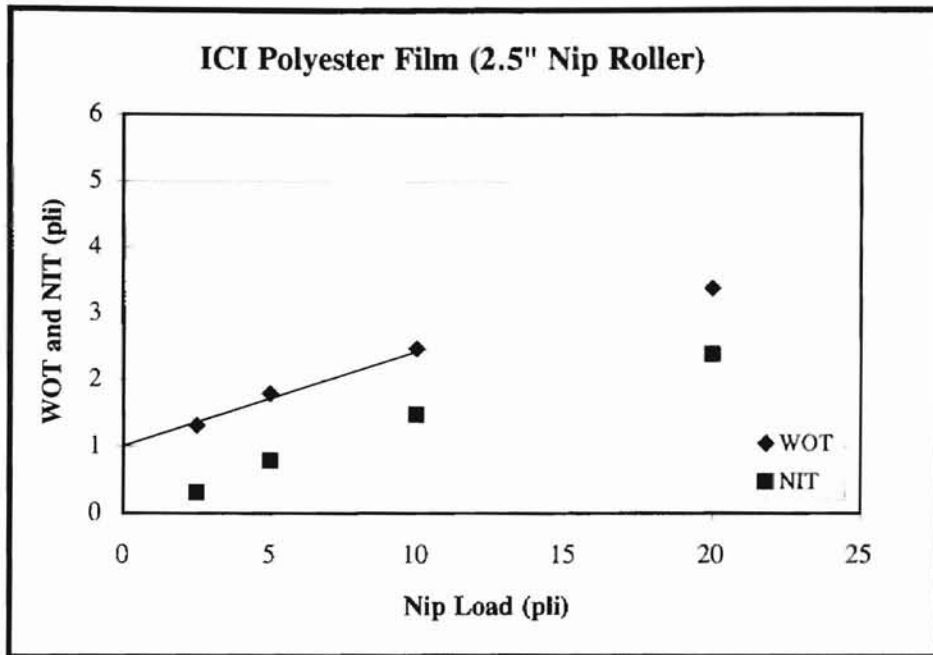

Figure 4.4 (a): WOT and NIT Vs. Nip Load for ICI Polyester film, for 2.5" Diameter Nip Roller. (Slope=0.15)

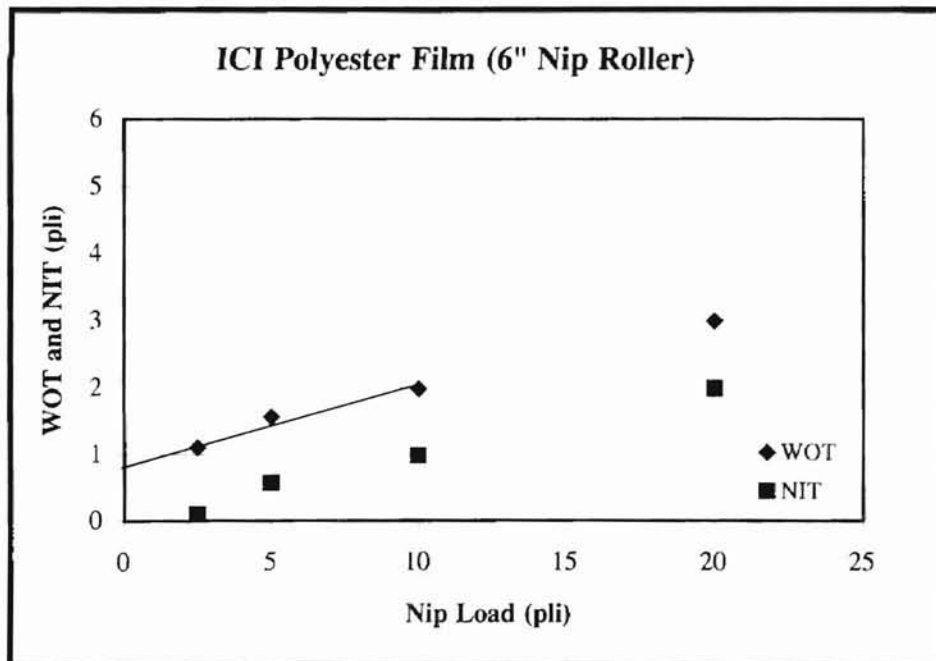

Figure 4.4 (b): WOT and NIT Vs. Nip Load for ICI Polyester film, for 6" Diameter Nip Roller. (Slope=0.12)

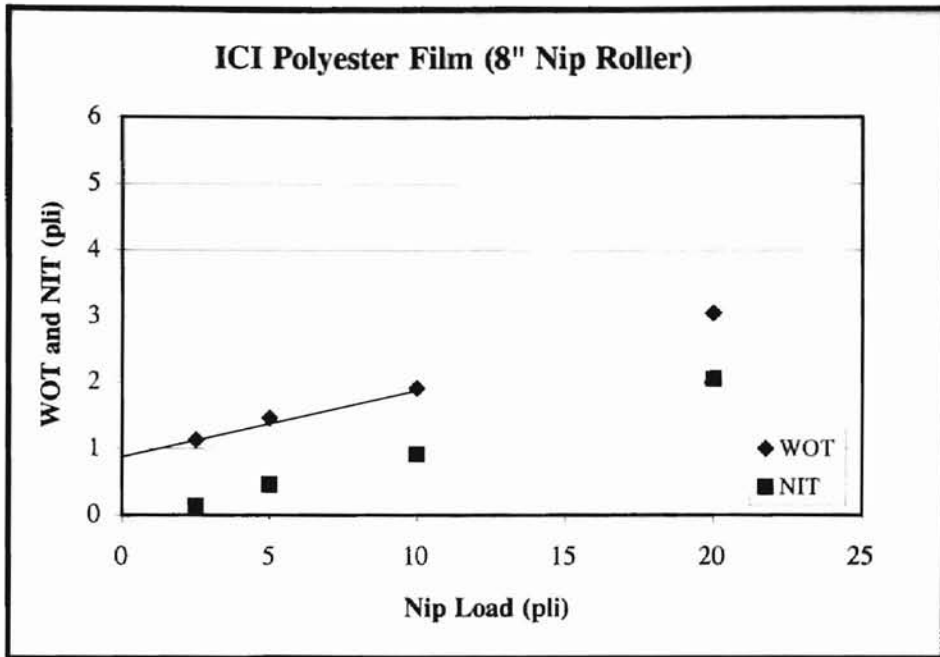

Figure 4.4 (c): WOT and NIT Vs. Nip Load for ICI Polyester film, for 8" Diameter Nip Roller. (Slope=0.1)

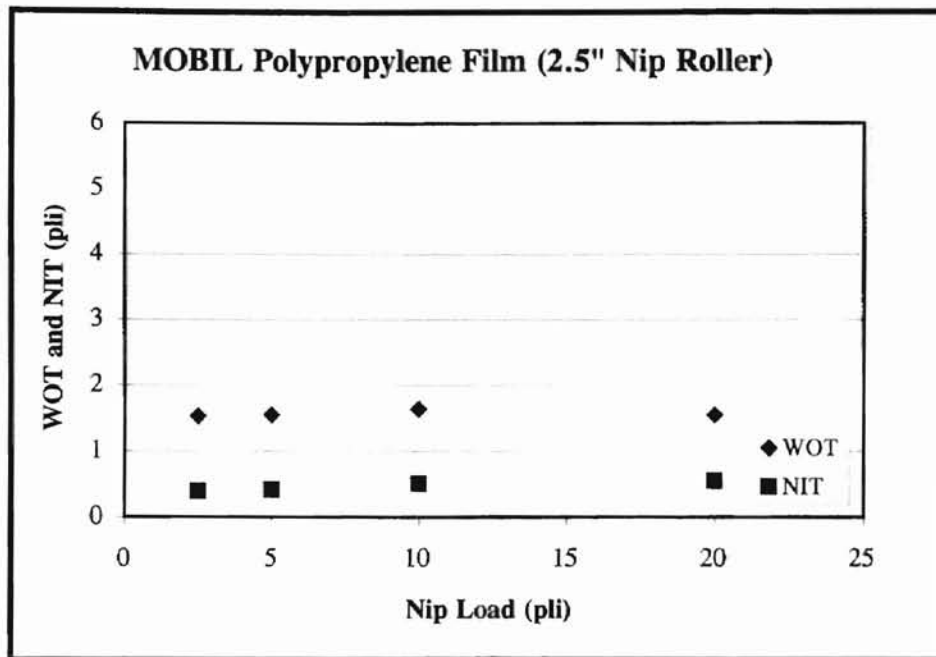

Figure 4.5 (a): WOT and NIT Vs. Nip Load for MOBIL Polypropylene film, for 2.5" Diameter Nip Roller.

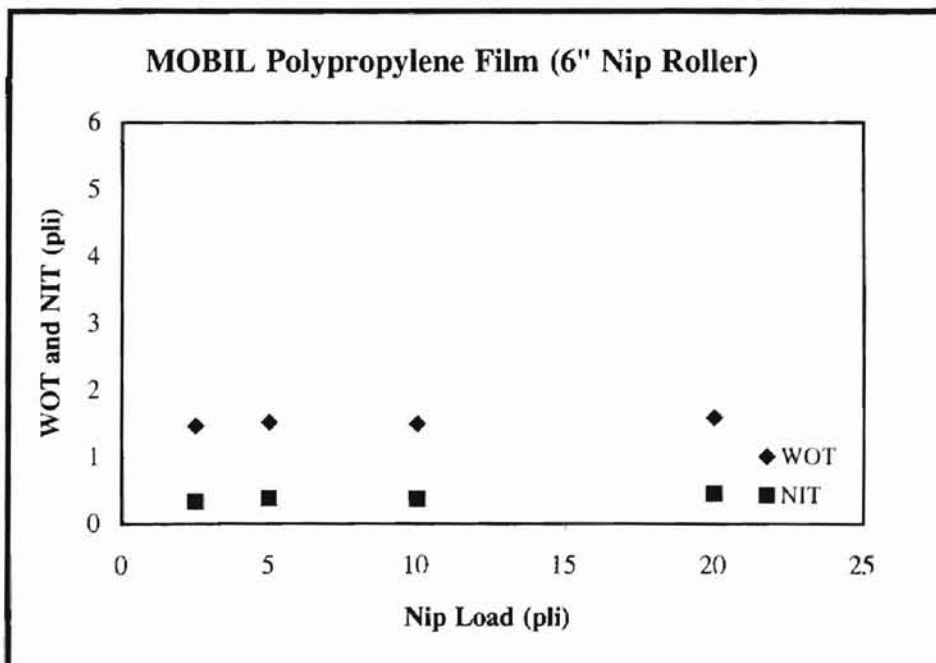

Figure 4.5 (b): WOT and NIT Vs. Nip Load for MOBIL Polypropylene film, for 6" Diameter Nip Roller.

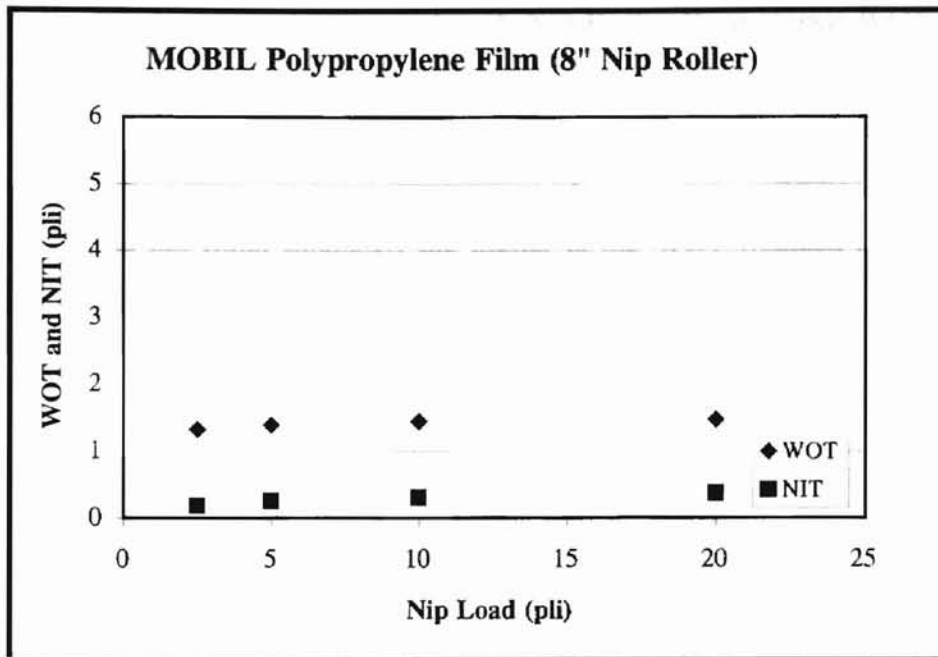

Figure 4.5 (c): WOT and NIT Vs. Nip Load for MOBIL Polypropylene film, for 8" Diameter Nip Roller.

4.2 WOT Vs. Nip Load (Superimposed with Nip Roller Diameters): WOT is plotted against nip roller diameter superimposed with different nip load. These graphs are plotted to study the effect of WOT with the increase in nip roller diameter. It can be observed that the lower the nip roller diameter, the higher is the WOT induced in wound rolls, figures 4.6-4.10.

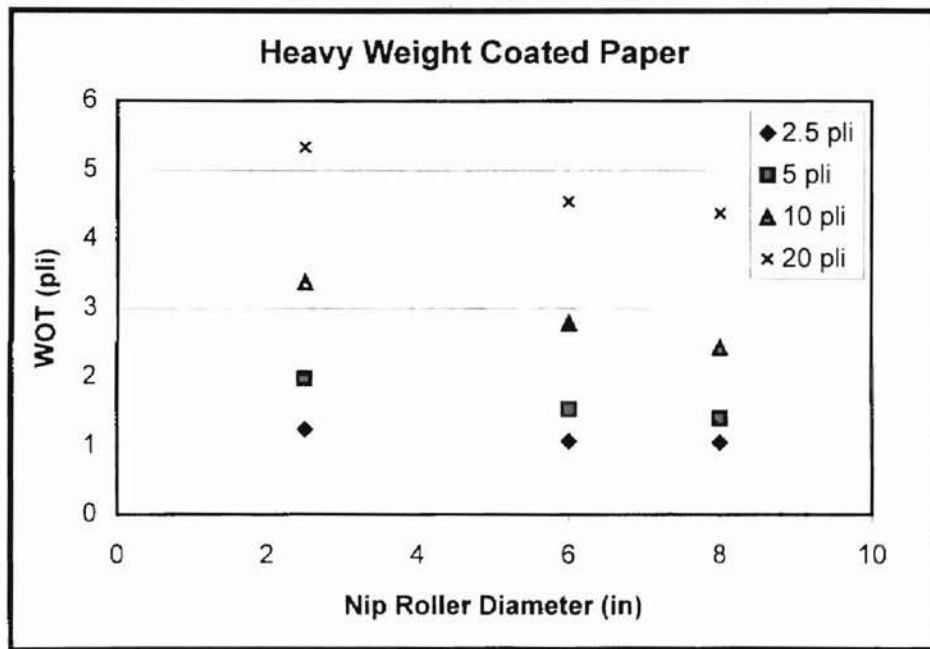

Figure 4.6: WOT Vs. Nip Load Diameter for Heavy Weight Coated Paper, for various Nip Loads.

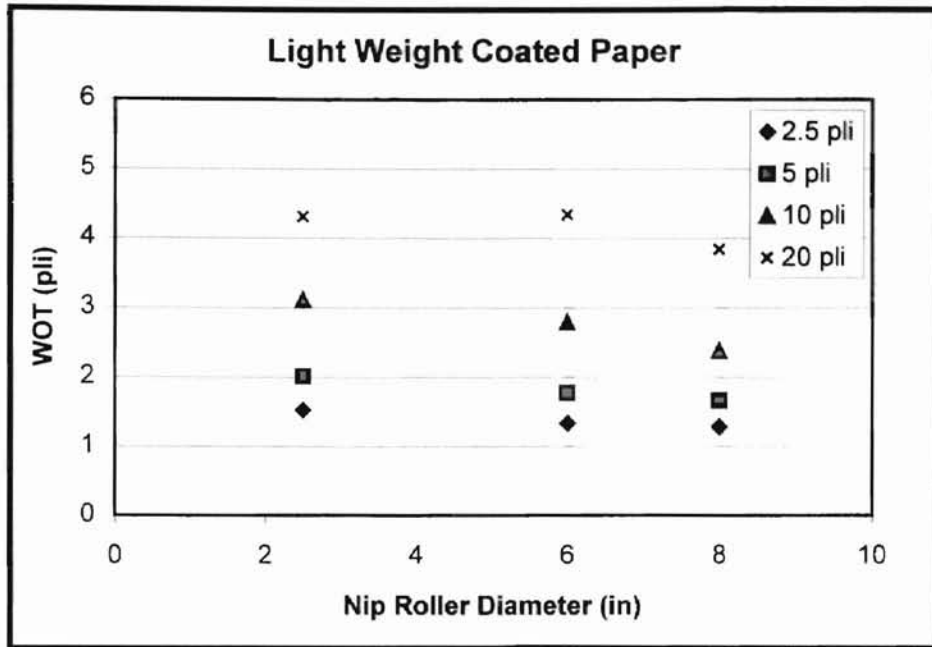

Figure 4.7: WOT Vs. Nip Load Diameter for Light Weight Coated Paper, for various Nip Loads.

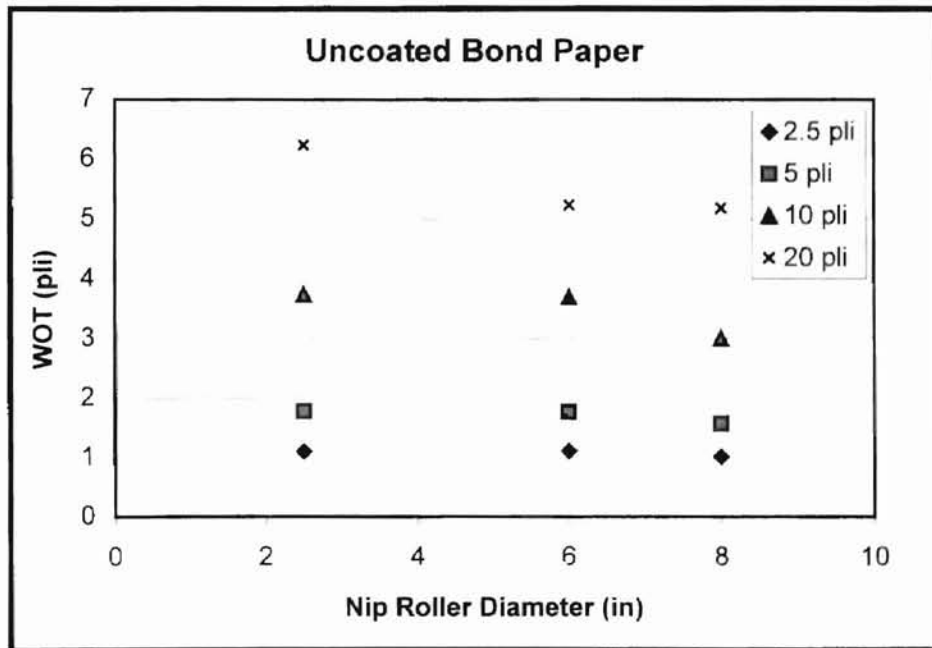

Figure 4.8: WOT Vs. Nip Load Diameter for Uncoated Bond Paper, for various Nip Loads.

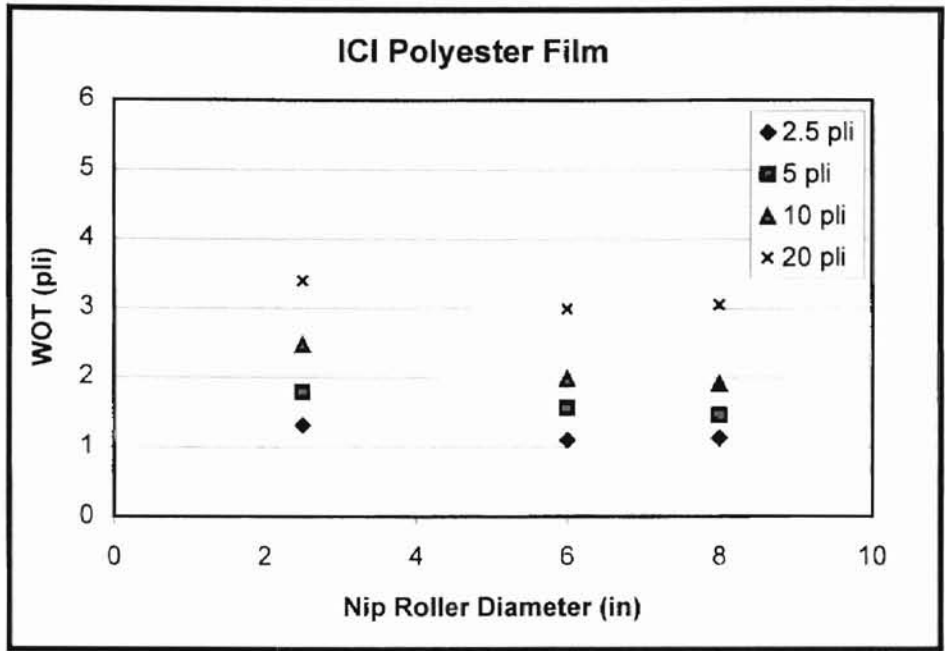

Figure 4.9: WOT Vs. Nip Load Diameter for ICI Polyester film, for various Nip Roller Diameters.

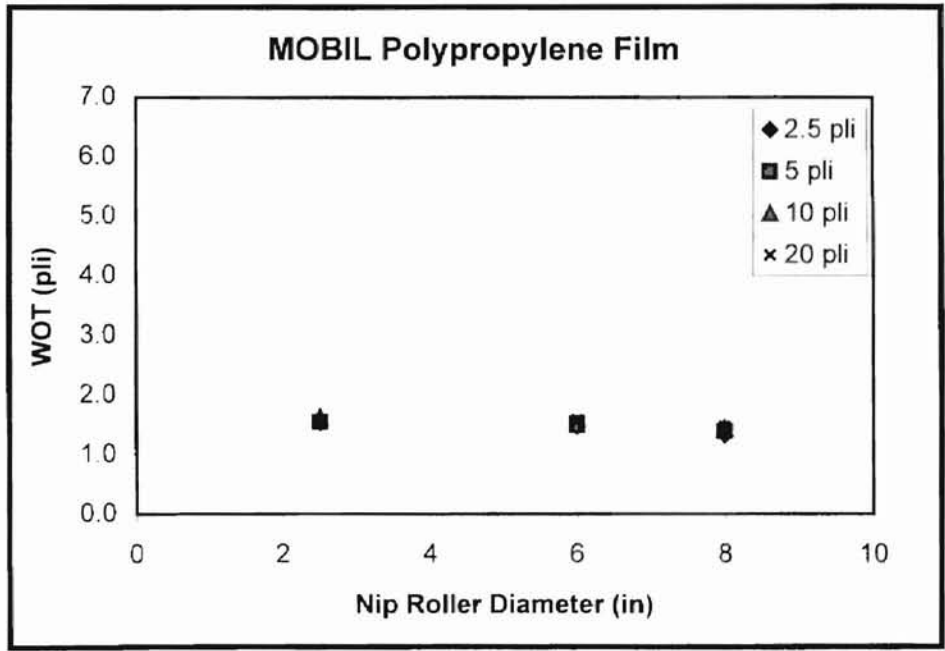

Figure 4.10: WOT Vs. Nip Load Diameter for MOBIL Polypropylene film, for various Nip Roller Diameters.

4.3 WOT and NIT vs. Nip Roller Diameter: WOT and NIT are plotted against nip load for different nip roller diameter, in Figures 4.11-4.15.

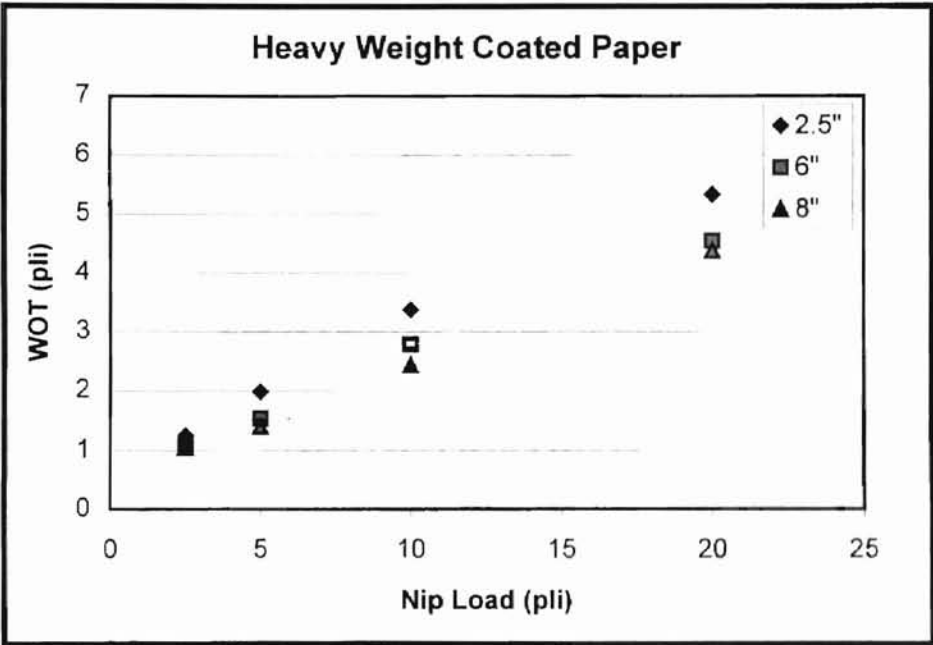

Figure 4.11: WOT Vs. Nip Roller Diameter for Heavy Weight Coated Paper, for various Nip Loads.

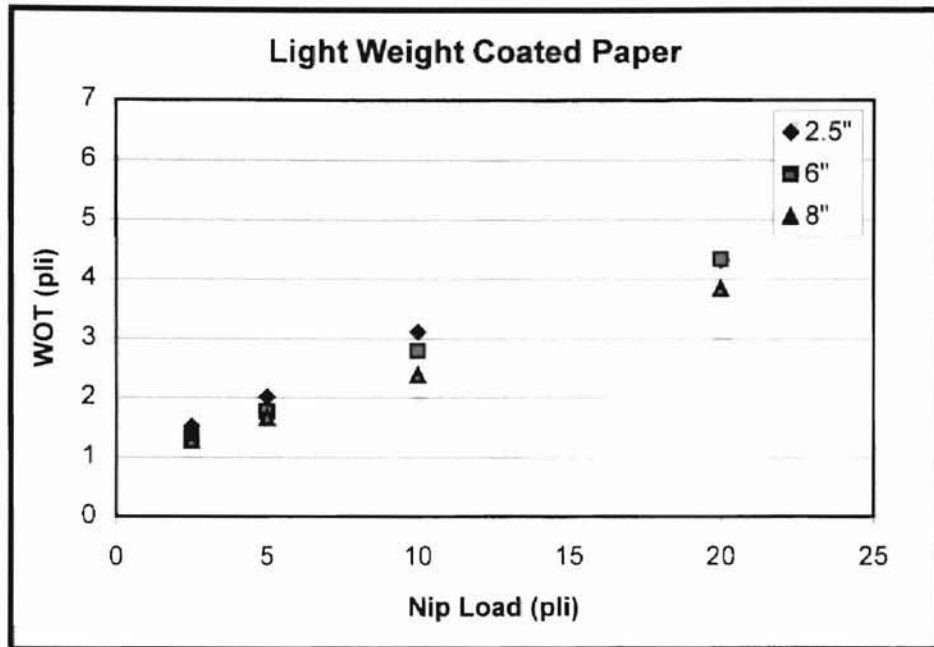

Figure 4.12: WOT Vs. Nip Roller Diameter for Light Weight Coated Paper, for various Nip Loads.

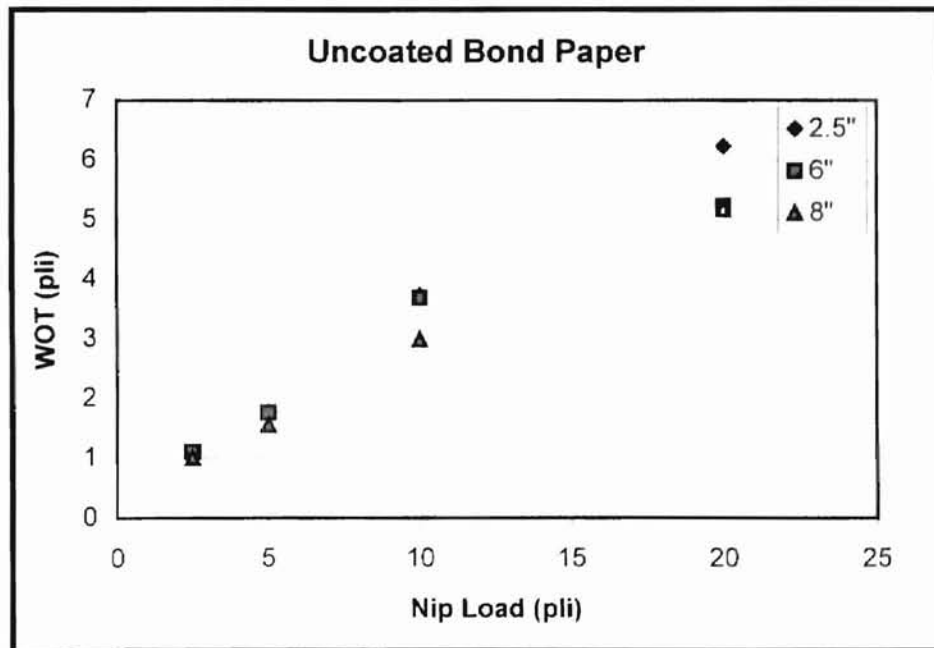

Figure 4.13: WOT Vs. Nip Roller Diameter for Uncoated Bond Paper, for various Nip Loads.

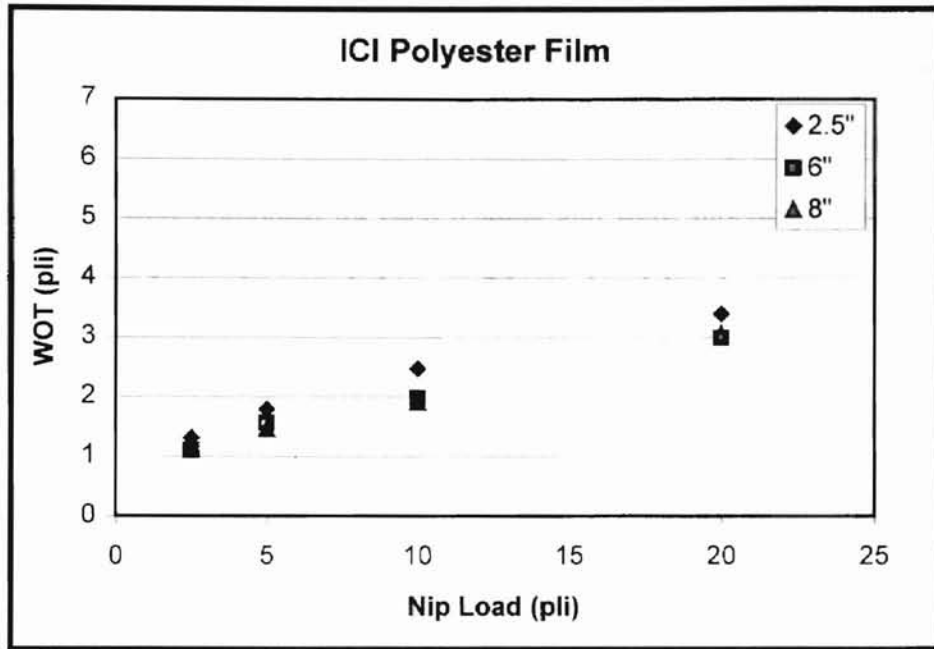

Figure 4.14: WOT Vs. Nip Roller Diameter for ICI Polyester film, for various Nip Loads.

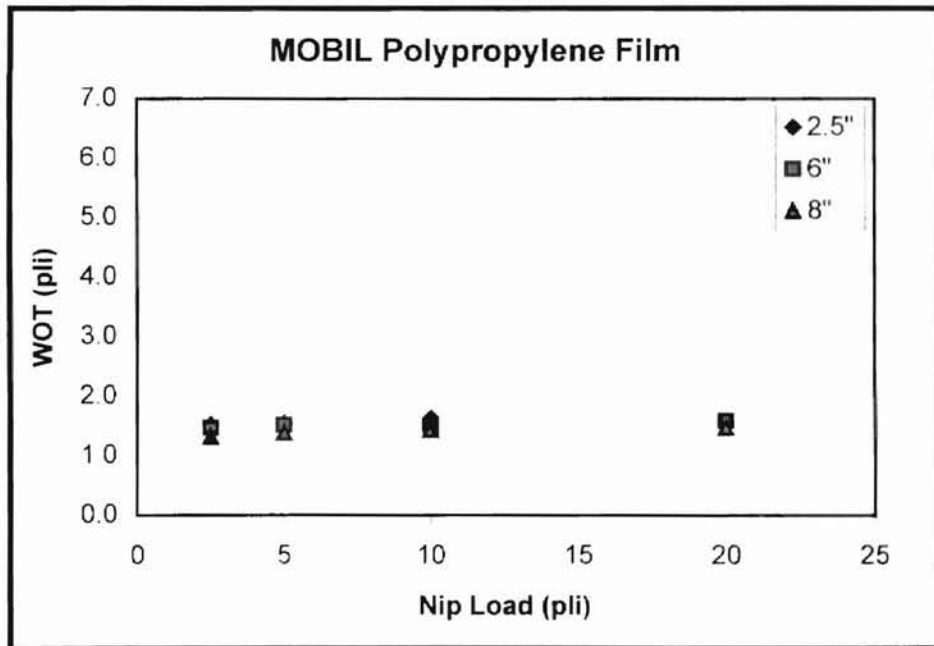

Figure 4.15: WOT Vs. Nip Roller Diameter for MOBIL Polypropylene film, for various Nip Loads.

4.4 NIT vs. Nip Load (Confidence Level): To verify the consistency of the results, all the experiments were conducted three times. By considering a normal distribution of NIT data, average NIT is plotted against Nip Load for various nip roller diameters. 95% confidence levels were computed for each reading and were superimposed with the NIT vs. Nip Load plot. It can be noted that confidence level bands are narrow for all the experiments conducted at less than 15 pli nip loads. As the nip load increases beyond 15 pli, the machine starts to lose its dynamic stability. However the machine is capable of winding under nip loads of 40 pli with a reduced confidence level. Plots for Heavy Weight Coated Paper are shown in figure 4.16. More plots for other materials are available in Appendix.

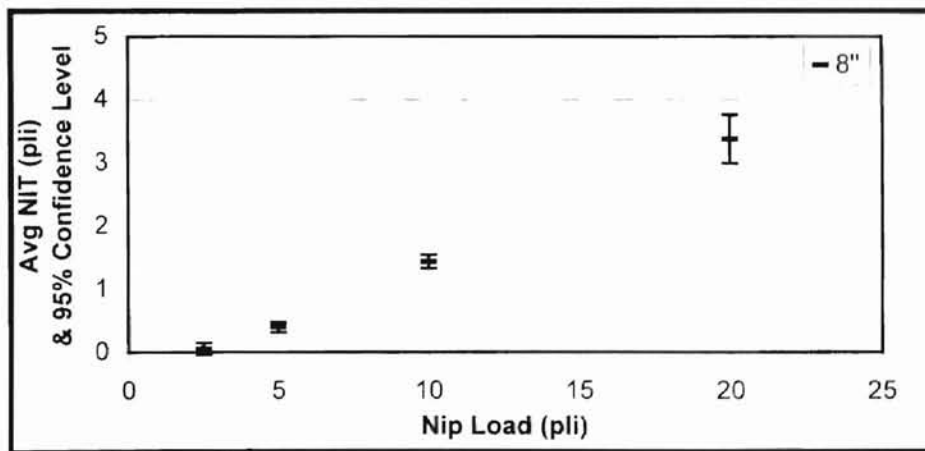
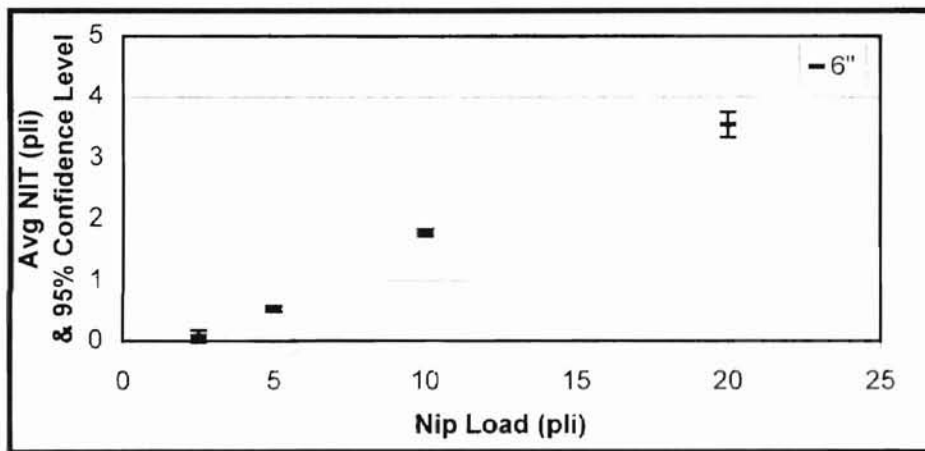
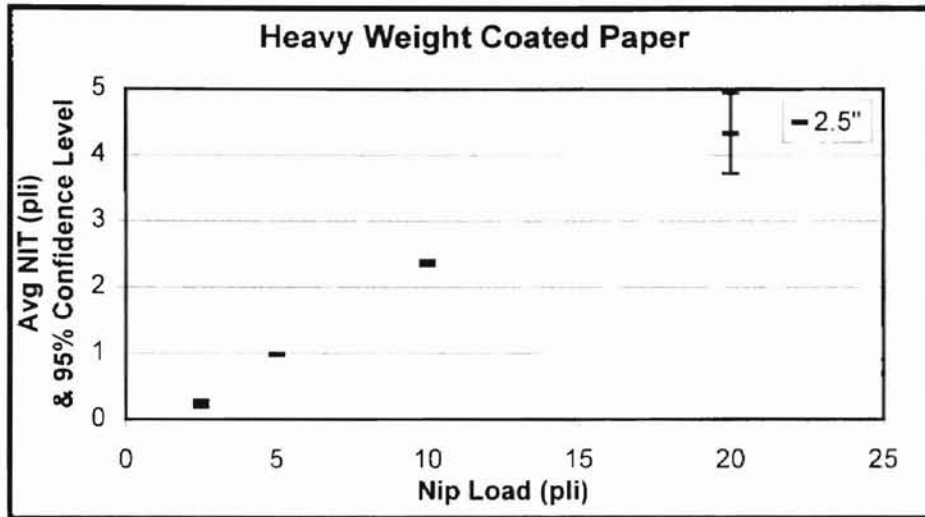

Figure 4.16: 95% Confidence level superimposed on Average NIT Vs Nip Load for HWC Paper, plotted for various Nip Roller Diameters.

4.5 Surface Roughness of Nip Rollers: The surface roughness of the nip rollers was measured to ensure that roughness was uniform across the roll width and that the roughness of the nip rollers was comparable. prior to the winding tests. The nip rolls were resurfaced with the intention that all three (2.5", 6" and 8" diameters) would have nearly the same roughness. Roughness measurements were carried out using the Mitutoyo Surftest Analyzer. Average roughness values (Ra) for all the nip rollers were plotted against length of the rollers and the graph is shown in figure 4.17. Measurements were taken along 6" of the roller length. Three sets of readings were taken around the circumference of the rollers and average values were plotted in the graph (figure 4.21). It can be observed from the graph that roughness values for all the three rollers were in the range of 20 microinches. 2.5" diameter nip roller was found to be smoothest (49 microinches). Roughness values of 6" and 8" diameter nip rollers were found close to each other (60 microinches for 6" and 58 microinches for 8" roller).

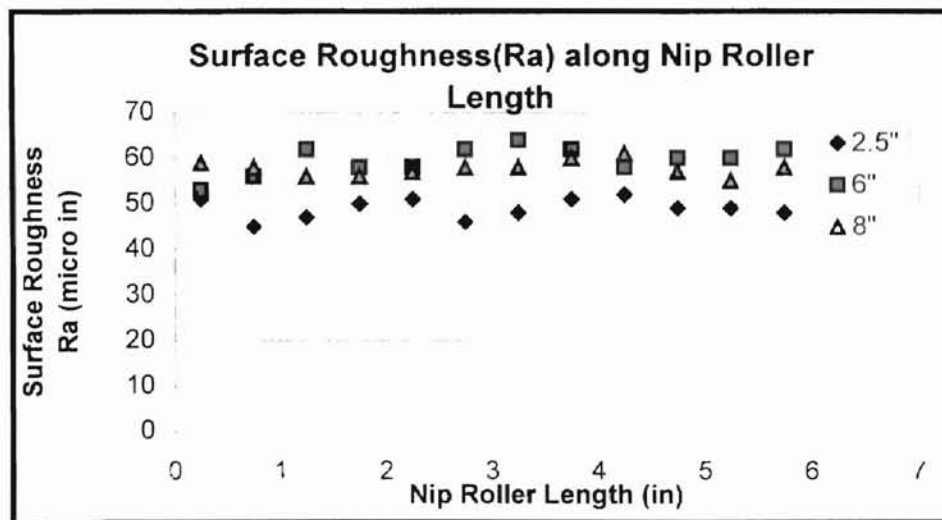

Figure 4.17: Surface roughness (Ra) along Nip Roller Length, plotted for various Nip Roller Diameters.

The variation in surface roughness among the three rollers is as low as can be obtained with on-campus facilities. This was a concern because the objective was to study the influence of nip roll diameter upon WOT. If the surface roughness had been radically different the experimental WOT data could have been influenced by both nip roll diameter and by surface roughness and it would have been impossible to discern the effects of nip roll diameter and surface roughness independently without many additional winding tests.

4.6 Coefficient of Friction between Web and Nip Roller Surface: After checking the surface roughness friction tests were conducted using the capstan expression,

$$\frac{T_1}{T_2} = e^{\mu\beta} \quad \dots(2)$$

Where T1 and T2 are tensions in the web on either side of the nip roll. μ is the coefficient of friction and β is the wrap angle. In these tests a dead weight was attached to one end of a length of web as shown in figure 4.18. The other end was attached to a hand held force gage. The web was wrapped about the roller in question, the roller was not allowed to rotate, by some arbitrary wrap angle which was set at 1.57 radians in these tests. The web was slowly drug over the roller surface and the average force required to maintain the motion was recorded. Thus this is a measure of the kinetic coefficient of friction between the two surfaces. Values obtained for different diameter rollers are shown in Table 4.1.

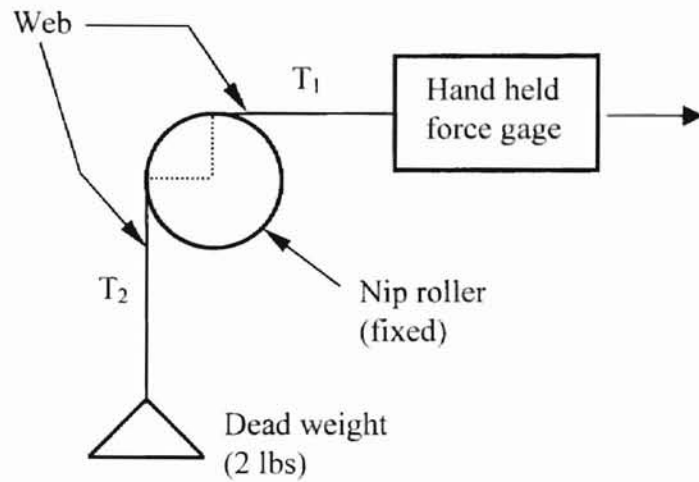

Figure 4.18: Schematic diagram of friction tests between nip roller and webs.

Material	2.5"	6"	8"
HWC	0.35	0.38	0.35
LWC	0.4	0.46	0.39
UCB	0.28	0.3	0.28

Table 4.2: Values of Kinetic Friction between Paper web materials and Aluminum rollers for 90 degrees wrap angle.

Note that the 2.5" and 8" rollers yield essentially the same friction for three paper materials. The 6" roller yielded a consistently higher result.

4.7 Discussion: Results obtained from figures 4.1-4.4 show that there is a rise in WOT as well as NIT with an increase in nip load for almost all web materials. This was, also, observed by Pfeiffer [1,2,3], Rand and Eriksson [4], Good and Wu [5] and Prabhakar [6] for newsprint material. The rate of increase of WOT and NIT decreases gradually with an increase in nip load. However this effect is less prominent in Uncoated Bond Paper (figure 4.3) and more prominent in ICI Polyester films (figure 4.4). It can also be observed that NIT increases in proportion with WOT as per the relation mentioned in equation (1). The nature of data points indicates that there is a constant rise in the WOT and NIT with nip load. Such behavior is observed because the normal force applied by nip is not enough to prevent the layers of paper from slippage. Slippage is predominant at low nip loads. As nip load increases and a zone of stick begins to build in the contact region, the WOT will increase less with nip load and at some nip load level the WOT may become independent of nip load. This can be due to the coefficient of friction and the internal pressure between the layers of web. For low friction materials such as HWC, LWC, UCB and polyester, WOT increases linearly up to a nip load of 2.5-10 pli. For high friction materials this may occur at low nip loads (less than 2.5 pli for MOBIL propylene, figure 4.5). However it is expected that this rising trend will gradually reduce when a zone of stick, no slip, develops between the outer layer and the layer beneath.

Figure 4.6-4.9 summarize the effect of nip roller diameter on WOT. Figures 4.11-4.15 shows the effect of increase in nip load on WOT plotted against nip roller diameter. It can be observed that for a particular nip load, WOT decreases with an increase in nip roller

diameter. From figures 4.6-4.9 and 4.11-4.14 it is evident that the nip load is much more important in determining the WOT than nip diameter. Graphs of WOT vs. nip load shown in figure 4.5, 4.10 and 4.15 indicate that MOBIL polypropylene is highly insensitive to increase in nip load and nip roller diameter. There seems to be no increase in WOT beyond 2.5 pli of nip load. A nip load of 2.5 pli seems to be enough to prevent the slippage in the polypropylene film layers. MPP films have the highest coefficient of friction and the lowest caliper (refer table 3.1) of all the web materials used in this research.

Table 4.2 shows the slope of WOT vs. nip load plot for low nip loads. It can be observed from table 4.2 that the WOT decreases with an increase in nip roller diameter.

Web Materials	Slope of WOT vs. Nip Load plot		
	2.5"	6"	8"
UCB	0.35	0.34	0.25
HWC	0.29	0.22	0.2
LWC	0.21	0.2	0.16
Polyester	0.15	0.12	0.1

Table 4.3: Slope of WOT vs. Nip Load Plots.

CHAPTER V

CONCLUSIONS

By conducting a series of winding experiments on five different web materials (table 3.1), a database has been developed successfully which correlates various winding parameters such as wound-on-tension (WOT), nip-induced-tension (NIT), nip load, web-line-tension, and nip roller diameter. This database will serve as a source of experimental data support, which can be used by future researchers for establishing winding models. The following conclusions can be derived from the experimental study carried out in the research.

1. It appears that web-line tension (T_w) directly affects WOT: In figures 4.6 through 4.9 it appears that the WOT would intercept the WOT axis at 1 pli, the web-line tension (T_w). This may be the case as well for MOBIL polypropylene but tests were not run at enough nip loads to provide proof.

2. High nip load and high coefficient of friction appear to limit the WOT: The light weight coated paper (LWC) results shown in figure 4.7, the ICI polyester results shown in figure 4.9 and the MOBIL polypropylene results shown in figure 4.10 support this. The

LWC and ICI polyester results show a decreasing rate of increase of WOT with respect to nip load between 10 and 20 pli. The MOBIL polypropylene's WOT has peaked at 2.5 pli.

3. Nip roll diameter is much less significant than nip load in determining WOT: This is evident in figures 4.6 through 4.10.

4. Increased nip roll diameter produces consistently less WOT: This is not a large effect but this trend is consistently seen in figures 4.11 through 4.15.

5. Over a range in nip load it appears that WOT and NIT are linearly proportional to nip load: This is apparent in figures 4.6 through 4.9. Good [7] suggested the WOT for centerwinding with an undriven nip should be of the form:

$$WOT = T_w + \mu_k N \quad \dots(3)$$

where WOT, web-line tension (T_w), and nip load (N) would have units of force/unit width. This would predict a slope of μ_k at low nip loads for the WOT versus nip load. Reviewing the results of calculations of these slopes and comparing to the friction values in Table 3.1 it is seen that the slopes are significantly less than μ_k for those webs.

Good et al's [7] work delivered this expression directly from pressures measured within the wound roll. This indicates that the WOT measurement technique is an interfering measurement.

6. WOT measurements are very repeatable: The 95% confidence intervals shown in figure 4.16 and figures A-1, A-2, A-3 and A-4 in Appendix, are proof of this. However, it can be noted that for all webs tested the confidence interval tends to increase with the nip load. From experience it appears that this is due to the winding apparatus being able to sustain a steady nip load.

7. Caliper and Tangential modulus (E_t) of the web does not have a significant impact on the WOT: HWC, LWC and HWC all have similar E_t as per table 3.1. The coefficient of friction is somewhat different but the web thickness (caliper) of UCB and HWC is about 2.4 times greater than LWC. From figures 4.6 through 4.8 it is apparent that WOT of LWC is only marginally less than HWC and UCB.

CHAPTER VI

FUTURE SCOPE

This work can now be applied to the design of more realistic WOT models. New models should be designed which can incorporate winding variables such as WOT, nip load, NIT, nip roller diameter and web-line tension as well as material characteristics like coefficient of friction, caliper and elastic modulus.

The WOT database created in this research can be extended to surface winding technique. Similar study can be conducted at different web-line speeds and at different web wrap angles at nip roller, to study their effects on WOT. Higher nip loads can be used on paper webs to find out the magnitude at which WOT becomes independent of nip loads.

REFERENCES

1. Pfeiffer, J. David, "Internal Pressures in a Wound Roll of Paper". TAPPI Journal, Vol. 49, No. 8, August 1966, pp. 342-347.
2. Pfeiffer, J. David, "Mechanics of a Rolling Nip on Paper Webs". TAPPI Journal, Vol. 51, No. 8, August 1968, pp. 77A-85A.
3. Pfeiffer, J. David, "Nip Forces and Their Effect on Wound-In-Tension". TAPPI Journal, Vol. 60, No. 2, February 1977, pp. 115-117.
4. Rand Thorkild, Eriksson Leif G., "Physical Properties of Newsprint Rolls during Winding". TAPPI Journal, Vol. 56, No. 6, June 1973, pp. 153-156.
5. Good J. K. and Wu Z., "The Mechanism of Nip-Induced-Tension in Wound Rolls". Journal of Applied Mechanics, Transactions of the ASME, Vol. 60, December 1993, pp. 942-947.
6. Prabhakar, M., "Study of the Effect of Nip Diameter upon the Rate of Nip-Induced-Tension". MS Report, Department of Mechanical and Aerospace Engineering, Oklahoma State University, May 1994.
7. Good J.K., Wu Z., and Fikes M.W.R., "The Internal Stresses in Wound Rolls with the Presence of a Nip Roller", Journal of Applied Mechanics, Transactions of ASME, Vol. 61, March 94, pp. 182-185.

8. Roisum David R., "The measurement of Web Stresses During Roll Winding", Ph.D. Thesis, Department of Mechanical and Aerospace Engineering, Oklahoma State University, May 1990.
9. Vaidyanathan N., "A Study on Wound Roll Slippage", Ph.D. Thesis, Department of Mechanical and Aerospace Engineering, Oklahoma State University, May 1996.

APPENDIX

MISCELLANEOUS EXPERIMENTAL RESULTS AND DATA TABLES

Tables A-1 through A-5 contain the actual results obtained from the winding experiments conducted at Web Handling Research Center (WHRC). These tables are presented for a ready reference for further data analysis. Graphs shown in figure A-1 through A-4 are plotted for nip-induced-tension (NIT) vs. nip load for 95% confidence levels for light weight coated paper, uncoated bond paper, ICI polyester film and MOBIL polypropylene film. Similar graph for heavy weight coated paper is shown in chapter four, figure 4.16.

Graphs of web-speed tension vs. roll radius for HWC and LWC paper (2.5" diameter nip roll) are shown in figures A-5 and A-6 respectively. Graph of web-line tension vs. roll radius for HWC and LWC (2.5" diameter nip roll) are shown in figures A-7 and A-8 respectively. Graphs of nip load vs. roll radius for HWC, LWC, UCB and ICI polyester (2.5" diameter nip roller) are shown in figures A-9-A12 respectively. Graphs of WOT vs. roll radius for HWC, LWC and UCB (8" diameter nip roller) are shown in figures A-13-A15 respectively.

Material: Heavy Weight Coated Paper
Web Tension: 6 lbs
Weblines Speed: 200 ft/min
Width of web: 6 in

Nip Load (pli)	Wound-On-Tension (WOT) (lbs)											
	2.5" Nip Roll				6" Nip Roll				8" Nip Roll			
	Test 1	Test 2	Test 3	Mean	Test 1	Test 2	Test 3	Mean	Test 1	Test 2	Test 3	Mean
2.50	1.25	1.33	1.13	1.24	1.19	1.16	0.87	1.07	1.15	1.15	0.86	1.05
5.00	1.98	2.00	1.95	1.98	1.61	1.53	1.44	1.53	1.48	1.48	1.22	1.40
10.00	3.45	3.32	3.33	3.37	2.83	2.66	2.85	2.78	2.32	2.32	2.65	2.43
20.00	4.90	4.54	6.56	5.33	4.39	4.28	4.96	4.54	4.05	3.91	5.15	4.37

Table A-1: Experimental results for Center Winding of Heavy Weight Coated (HWC) paper.

Material: Light Weight Coated Paper
Web Tension: 6 lbs
Weblines Speed: 200 ft/min
Width of web: 6 in

Nip Load (pli)	Wound-On-Tension (WOT) (lbs)											
	2.5" Nip Roll				6" Nip Roll				8" Nip Roll			
	Test 1	Test 2	Test 3	Mean	Test 1	Test 2	Test 3	Mean	Test 1	Test 2	Test 3	Mean
2.50	1.51	1.53	1.52	1.52	1.28	1.30	1.40	1.33	1.26	1.28	1.30	1.28
5.00	2.07	1.65	2.31	2.01	1.63	1.69	2.00	1.77	1.60	1.59	1.80	1.66
10.00	3.00	2.97	3.38	3.11	2.56	2.72	3.10	2.79	2.21	2.21	2.74	2.38
20.00	4.22	4.00	4.71	4.31	4.02	4.32	4.68	4.34	3.29	3.82	4.40	3.84

Table A-2: Experimental results for Center Winding of Light Weight Coated (LWC) paper.

Material: Uncoated Bond Paper
Web Tension: 6 lbs
Weblines Speed: 200 ft/min
Width of web: 6 in

Nip Load (pli)	Wound-On-Tension (WOT) (lbs)											
	2.5" Nip Roll				6" Nip Roll				8" Nip Roll			
	Test 1	Test 2	Test 3	Mean	Test 1	Test 2	Test 3	Mean	Test 1	Test 2	Test 3	Mean
2.50	1.17	1.15	0.98	1.10	1.24	1.30	0.79	1.11	1.14	1.22	0.66	1.01
5.00	1.62	1.76	1.95	1.78	1.80	1.79	1.73	1.77	1.60	1.72	1.40	1.57
10.00	3.82	3.55	3.85	3.74	3.85	3.80	3.44	3.70	2.78	3.02	3.21	3.00
20.00	5.80	5.76	7.12	6.23	4.91	5.00	5.77	5.23	4.91	5.14	5.49	5.18

Table A-3: Experimental results for Center Winding of Ucoated Bond (UCB) paper.

Material: ICI Polyester Film
Web Tension: 6 lbs
Weblines Speed: 200 ft/min
Width of web: 6 in

Nip Load (pli)	Wound-On-Tension (WOT) (lbs)											
	2.5" Nip Roll				6" Nip Roll				8" Nip Roll			
	Test 1	Test 2	Test 3	Mean	Test 1	Test 2	Test 3	Mean	Test 1	Test 2	Test 3	Mean
2.50	1.26	1.26	1.41	1.31	0.87	0.95	1.47	1.10	0.97	1.05	1.38	1.13
5.00	1.71	1.73	1.94	1.79	1.41	1.53	1.76	1.56	1.32	1.36	1.71	1.46
10.00	2.43	2.42	2.57	2.47	1.77	1.63	2.54	1.98	1.71	1.75	2.29	1.91
20.00	3.44	3.45	3.30	3.39	2.89	2.64	3.43	2.99	2.89	2.77	3.51	3.05

Table A-4: Experimental results for Center Winding of ICI Polyester Film.

Material: MOBIL Polypropylene Film
Web Tension: 6 lbs
Weblines Speed: 200 ft/min
Width of web: 6 in

Nip Load (pli)	Wound-On-Tension (WOT) (lbs)											
	2.5" Nip Roll				6" Nip Roll				8" Nip Roll			
	Test 1	Test 2	Test 3	Mean	Test 1	Test 2	Test 3	Mean	Test 1	Test 2	Test 3	Mean
2.50	1.62	1.62	1.35	1.53	1.56	1.50	1.33	1.47	1.32	1.34	1.29	1.32
5.00	1.65	1.64	1.37	1.55	1.58	1.59	1.39	1.52	1.42	1.40	1.35	1.39
10.00	1.64	1.70	1.59	1.64	1.52	1.58	1.41	1.50	1.45	1.47	1.40	1.44
20.00	1.55	1.55	1.55	1.55	1.64	1.66	1.47	1.59	1.47	1.50	1.44	1.47

Table A-5: Experimental results for Center Winding of MOBIL Polypropylene Film.

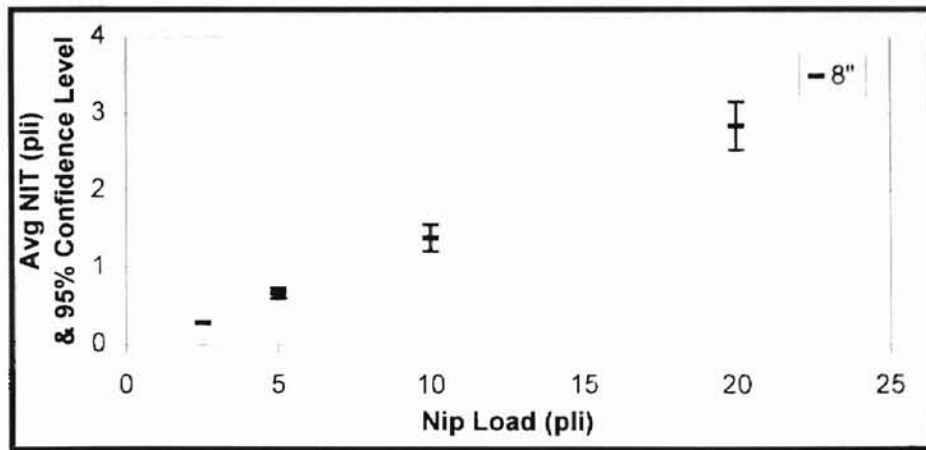
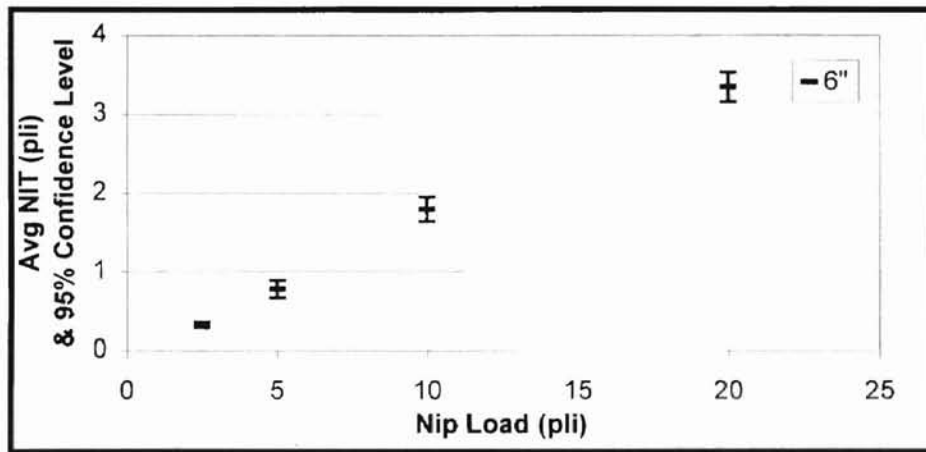
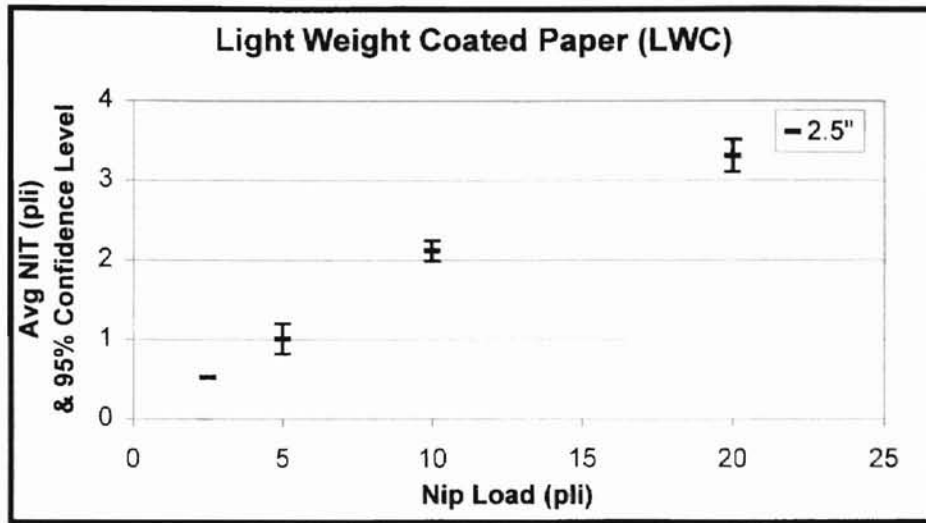

Figure A-1: 95% Confidence level superimposed on Average NIT vs. Nip Load for LWC paper, plotted for various Nip Roller Diameters.

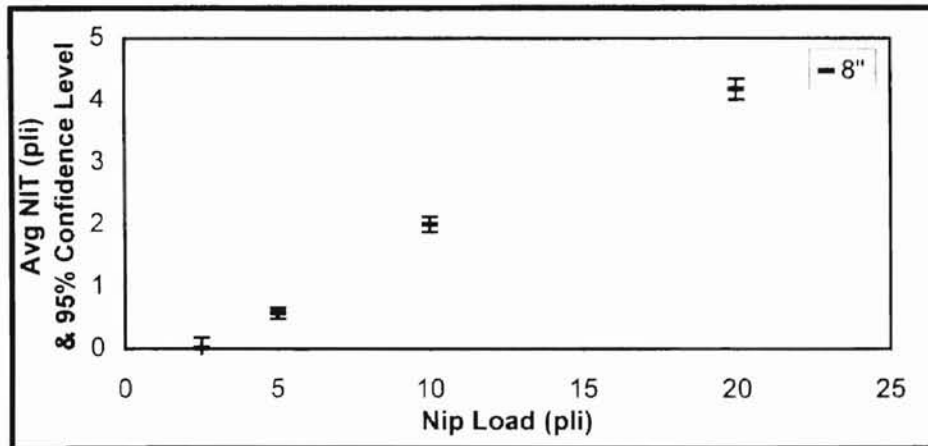
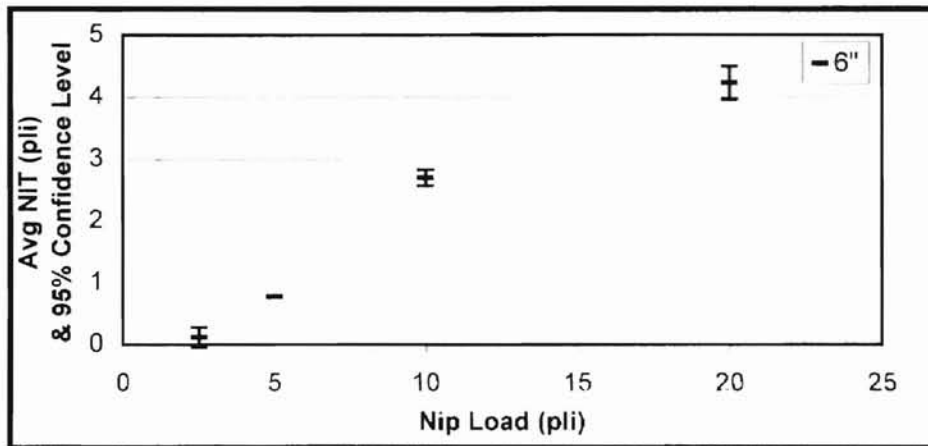
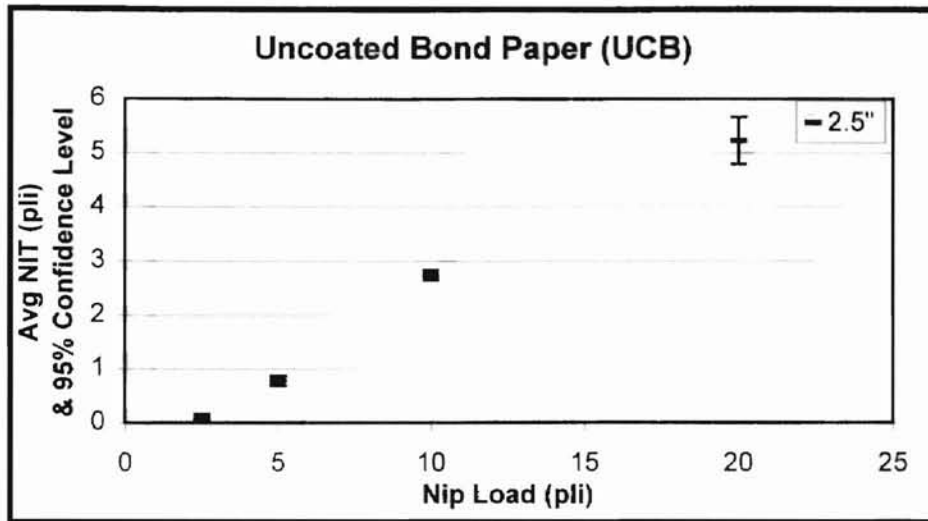

Figure A-2: 95% Confidence level superimposed on Average NIT vs. Nip Load for UCB paper, plotted for various Nip Roller Diameters.

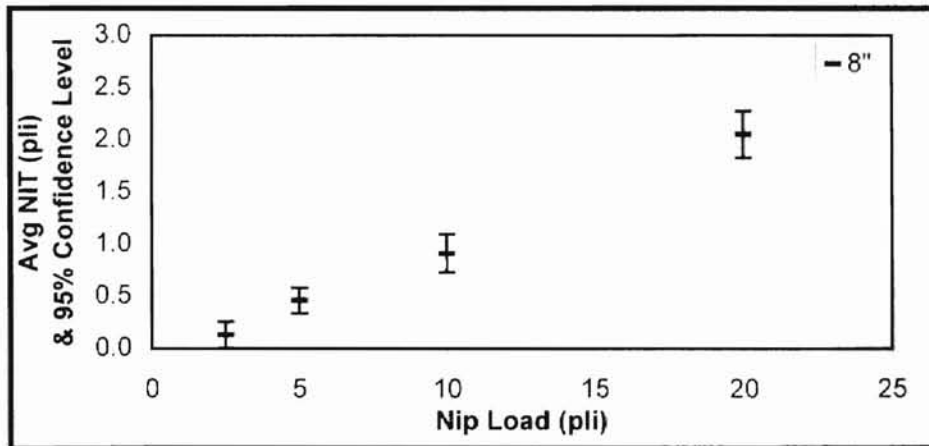
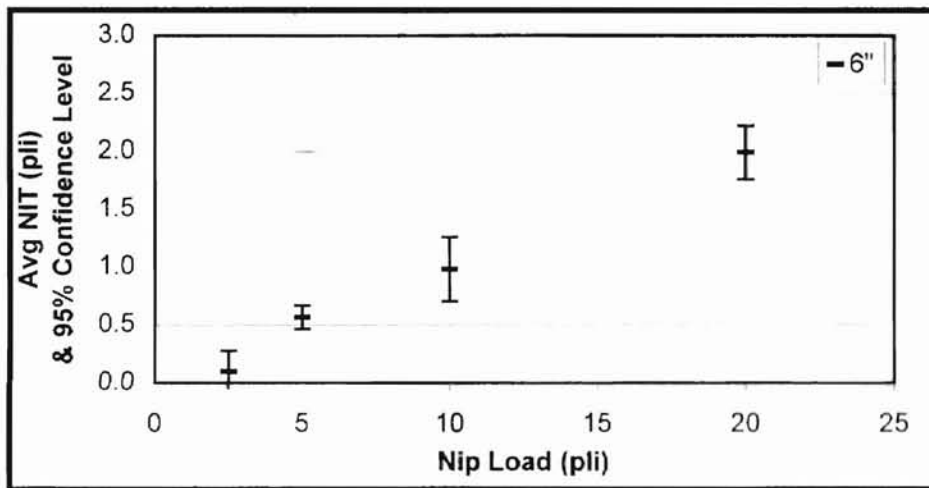
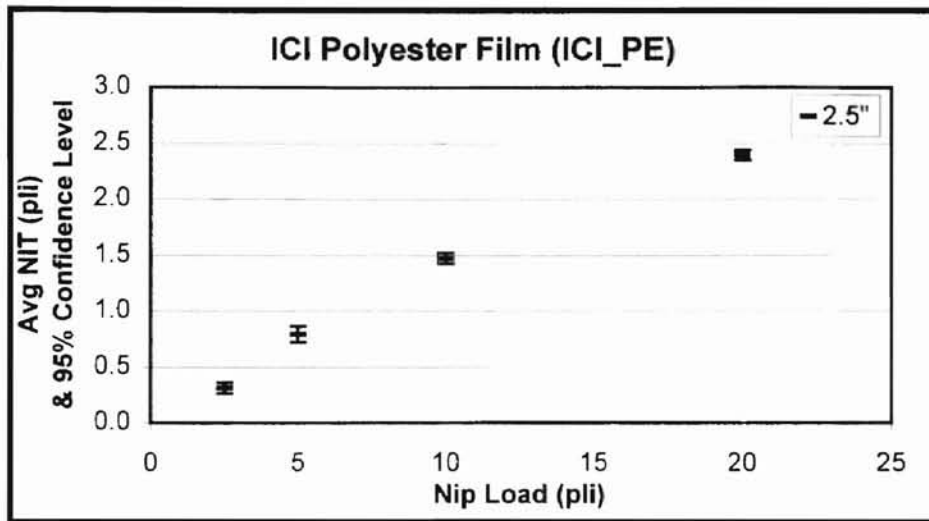

Figure A-3: 95% Confidence level superimposed on Average NIT vs. Nip Load for ICI polyester film, plotted for various Nip Roller Diameters.

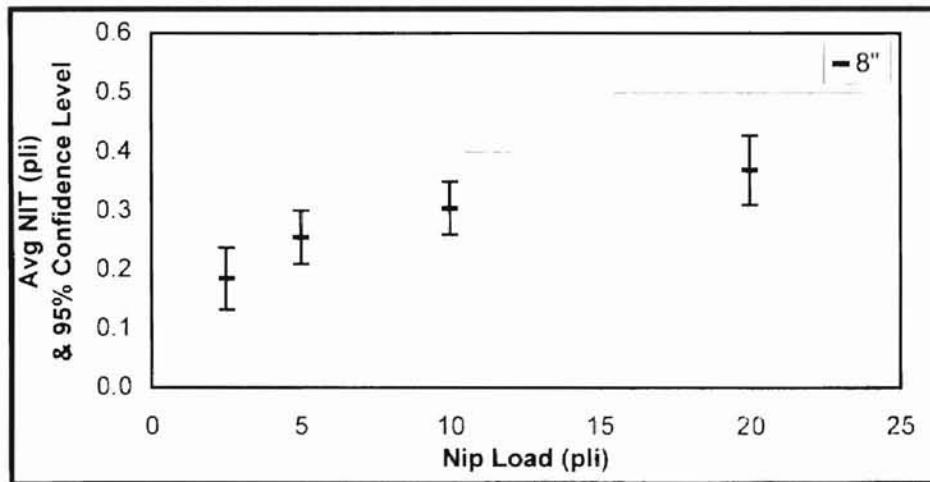
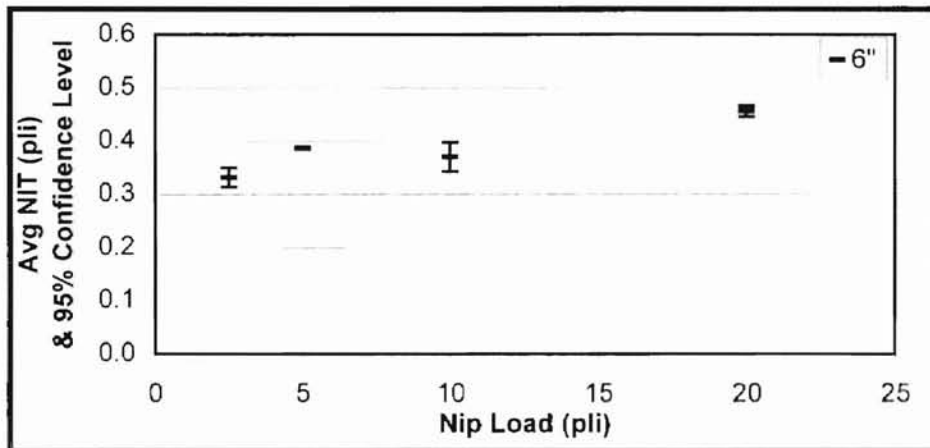
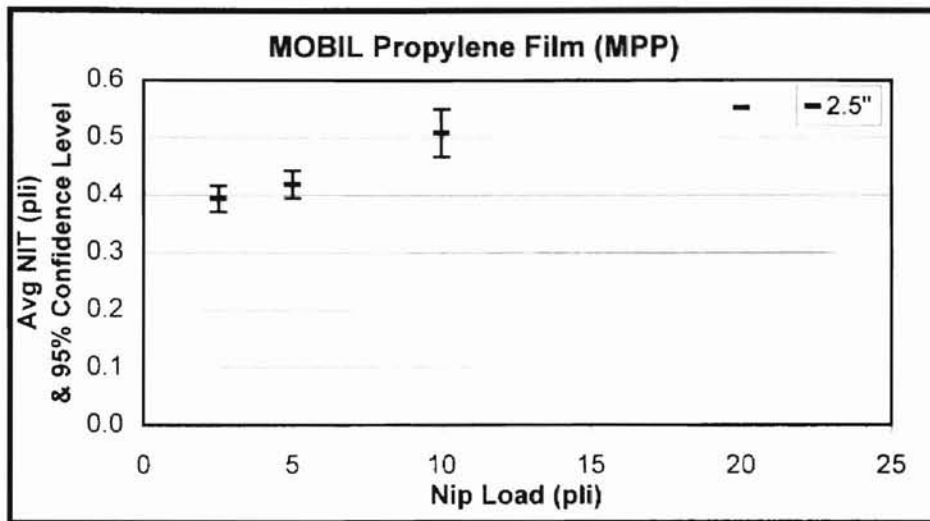

Figure A-4: 95% Confidence level superimposed on Average NIT vs. Nip Load for MOBIL polypropylene film, plotted for various Nip Roller Diameters.

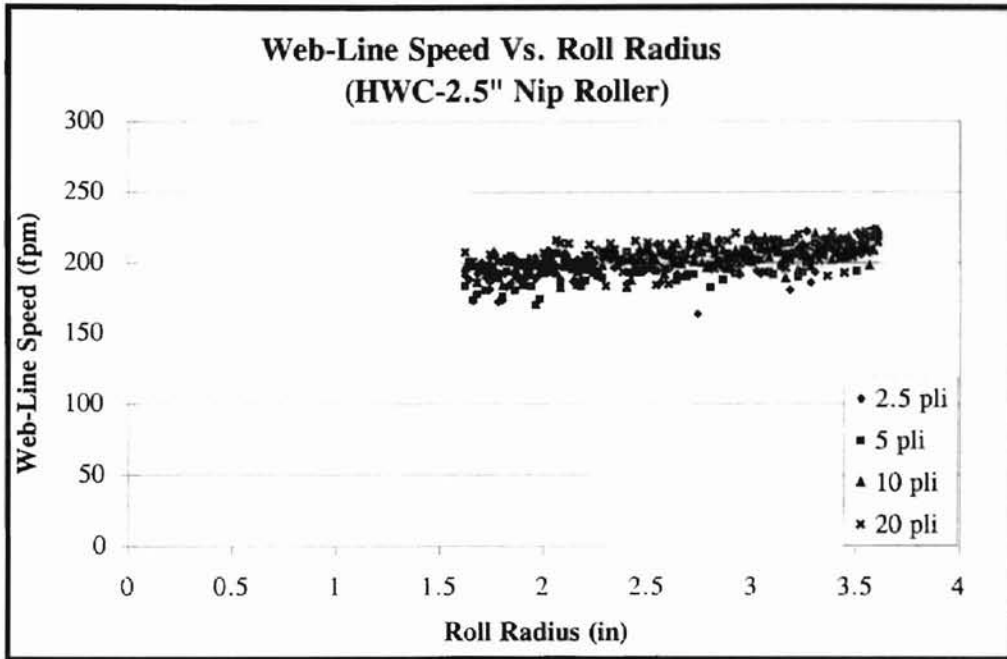

Figure A-5: Web-line speed vs. roll radius, plotted for HWC paper (2.5" diameter nip roll).

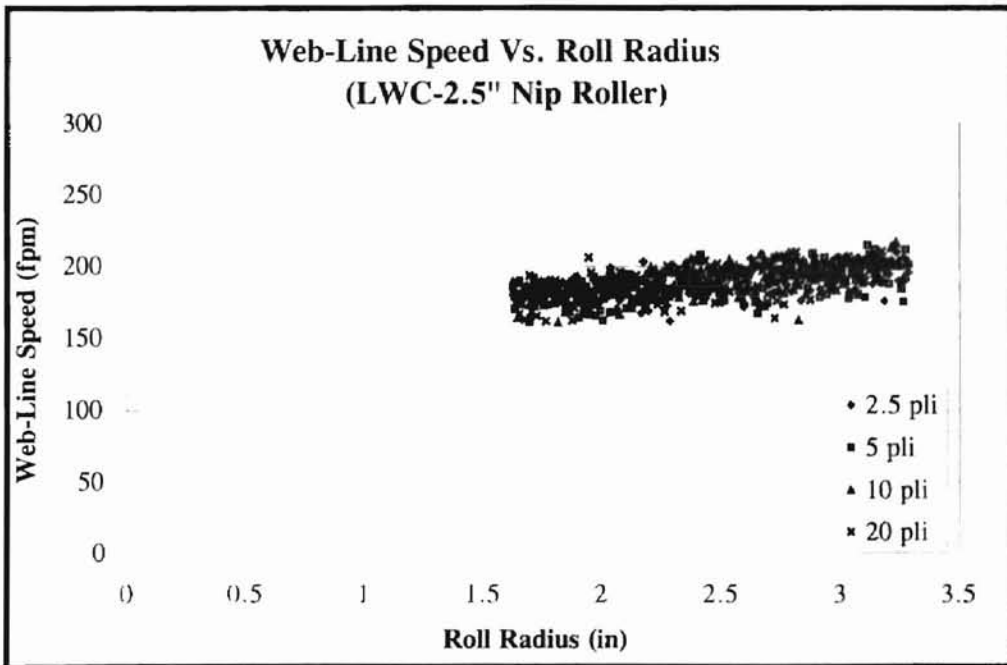

Figure A-6: Web-line speed vs. roll radius, plotted for LWC paper (2.5" diameter nip roll).

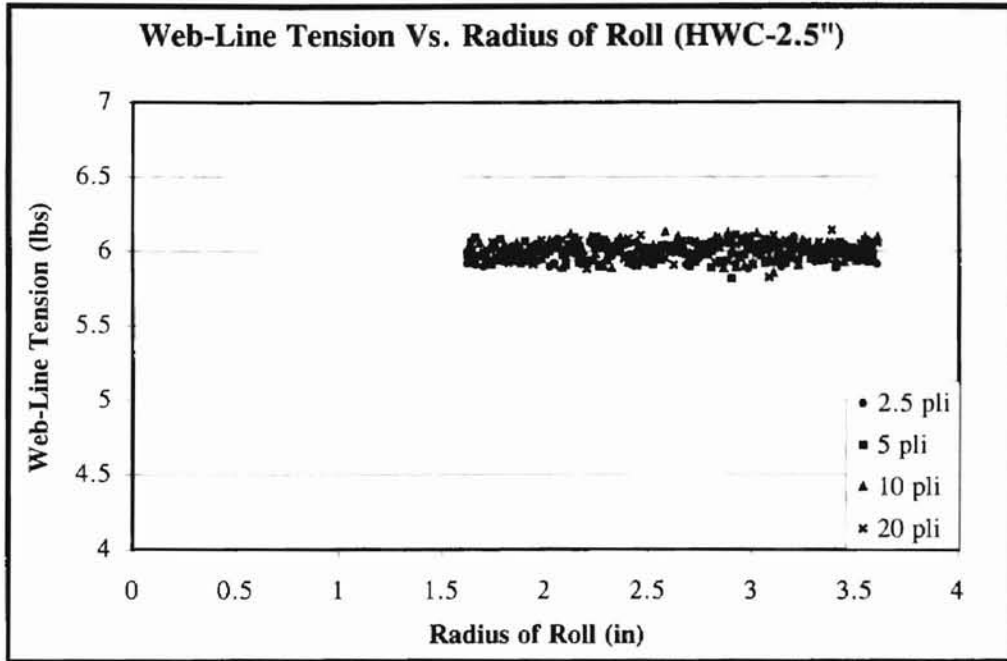

Figure A-7: Web-line tension vs. roll radius, plotted for HWC paper (2.5" diameter nip roll).

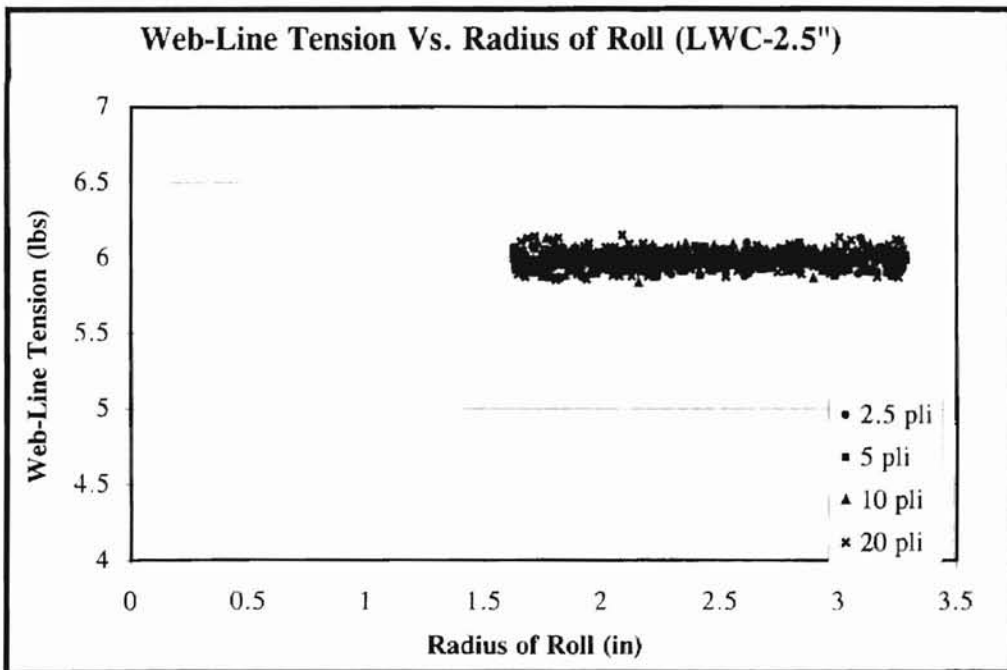

Figure A-8: Web-line tension vs. roll radius, plotted for LWC paper (2.5" diameter nip roll).

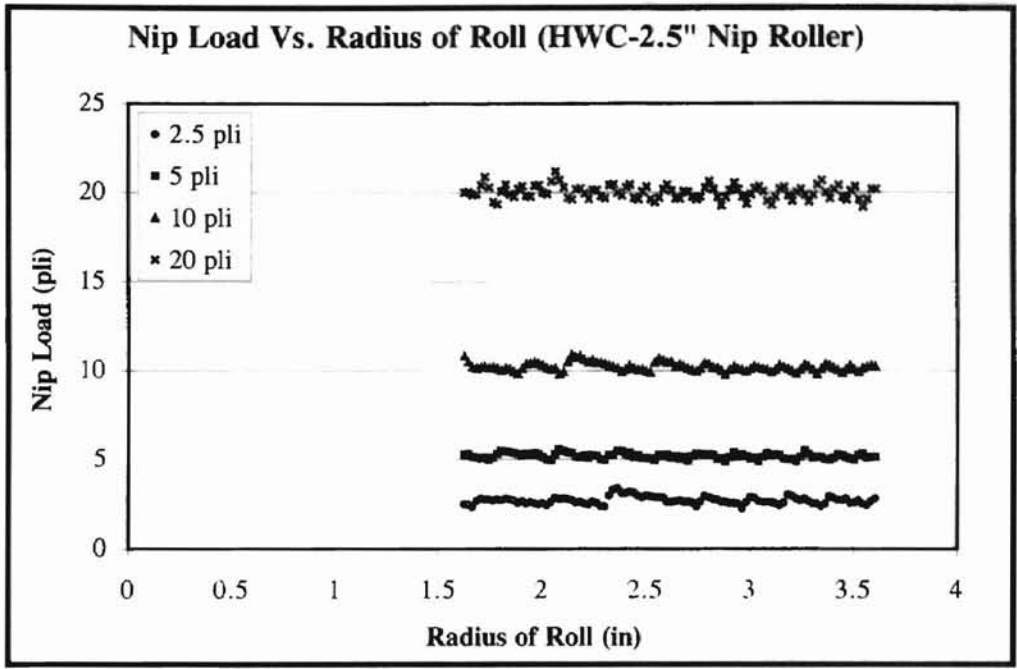

Figure A-9: Nip load vs. roll radius, plotted for HWC paper (2.5" diameter nip roll).

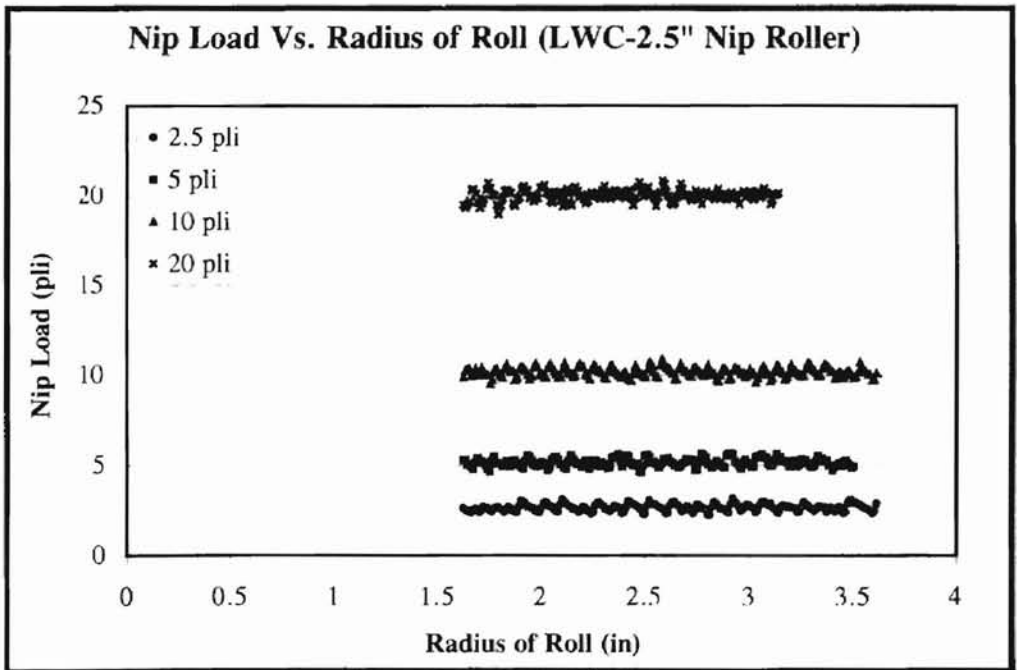

Figure A-10: Nip load vs. roll radius, plotted for LWC paper (2.5" diameter nip roll).

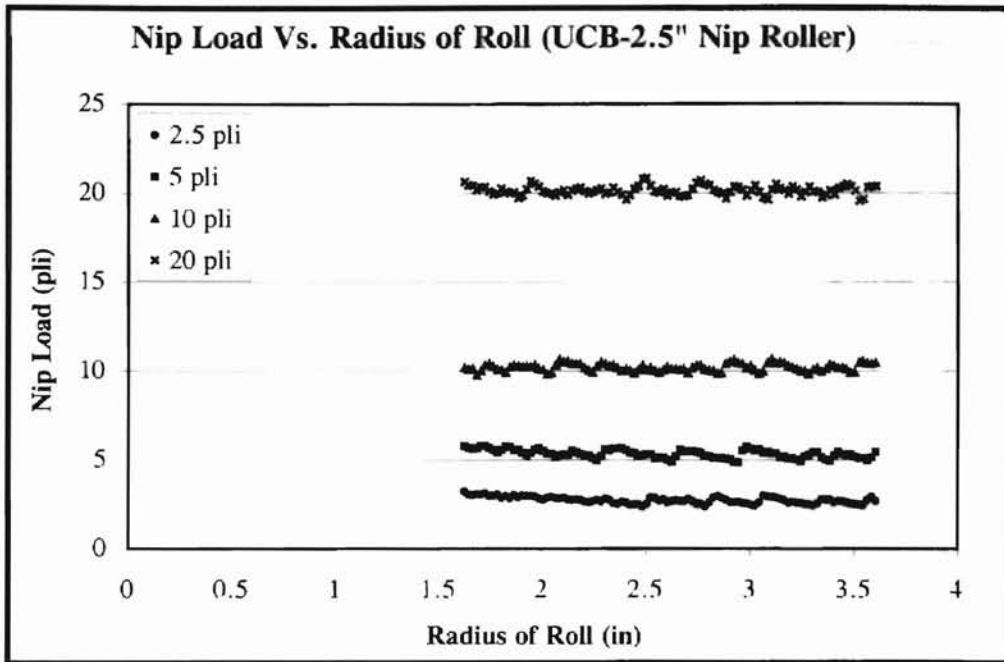

Figure A-11: Nip load vs. roll radius, plotted for UCB paper (2.5" diameter nip roll).

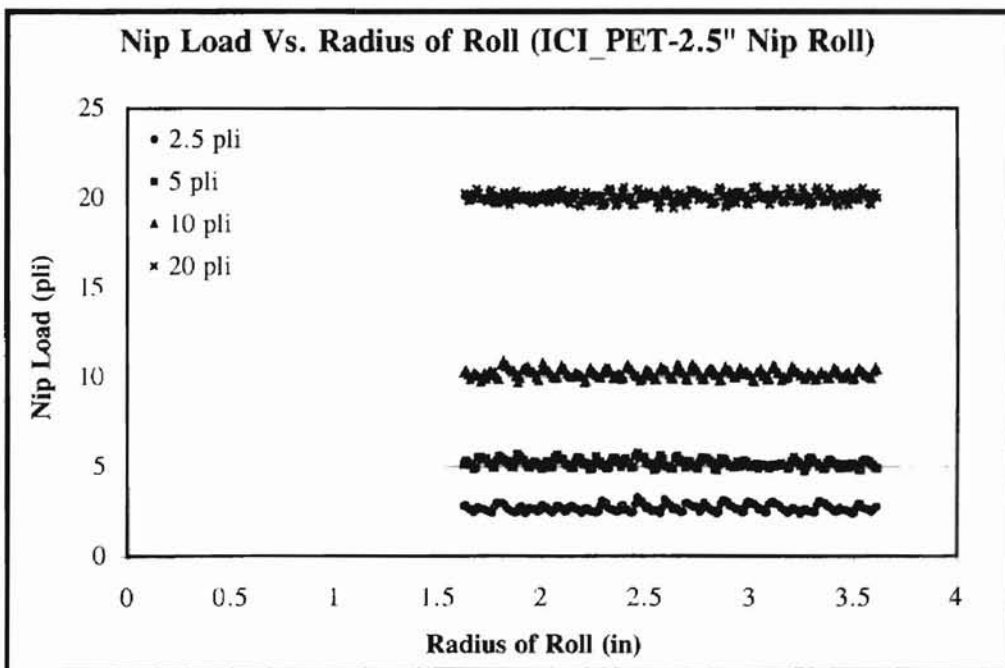

Figure A-12: Nip load vs. roll radius, plotted for ICI Polyester film (2.5" diameter nip roll).

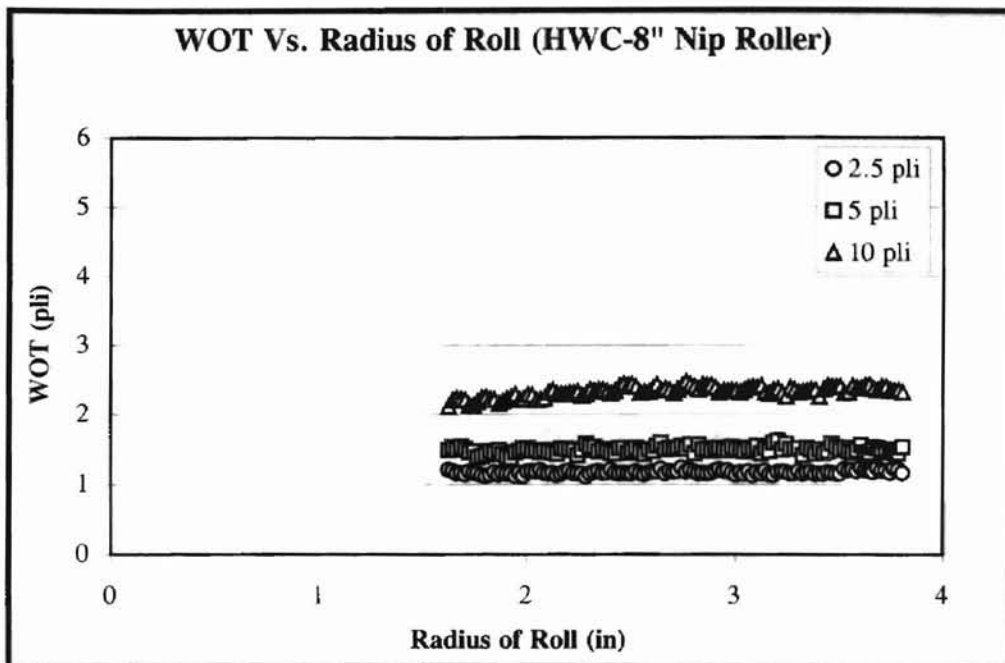

Figure A-13: WOT vs. roll radius, plotted for HWC paper (8" diameter nip roll).

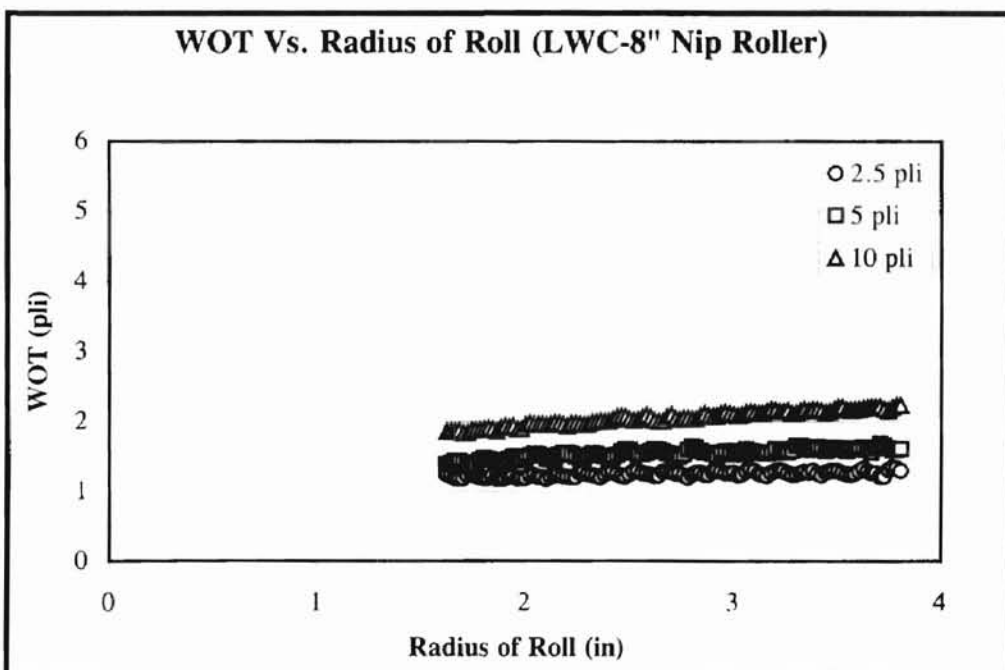

Figure A-14: WOT vs. roll radius, plotted for LWC paper (8" diameter nip roll).

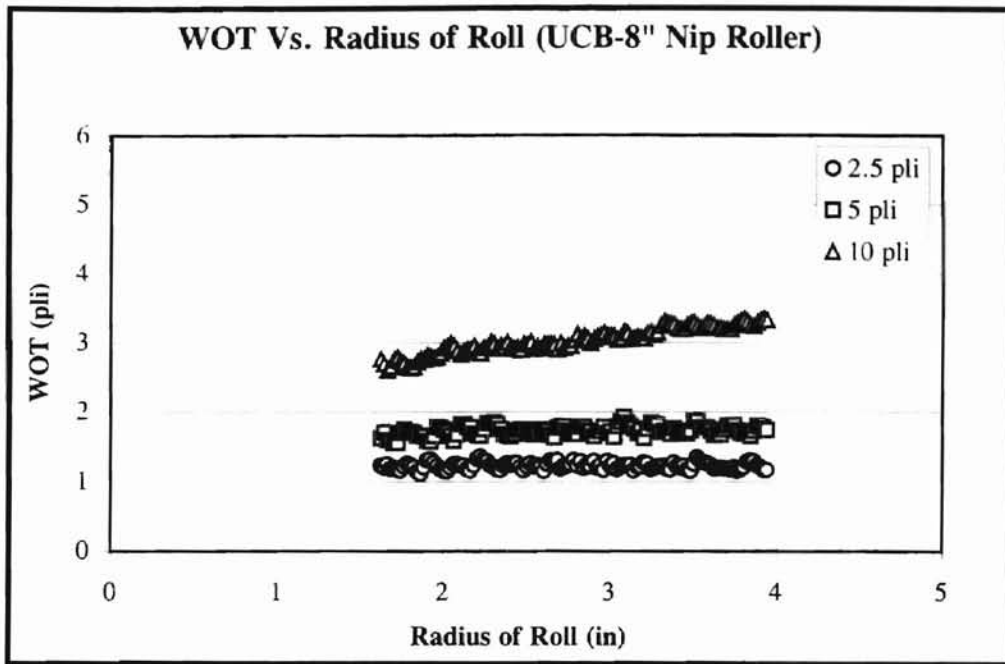

Figure A-15: WOT vs. roll radius, plotted for UCB paper (8" diameter nip roll).

2
VITA

Mandar Marfatia

Candidate for the Degree of

Master of Science

Thesis: EFFECT OF WEB CHARACTERISTICS ON WOUND-ON-TENSION IN
WINDING

Major Field: Mechanical Engineering

Biographical:

Personal Data: Born in Bombay, India, on May 1, 1974, the son of Shri. Shailesh Marfatia and Smt. Nirmala Marfatia.

Education: Received Bachelor of Engineering Degree in Mechanical Engineering from Vishwakama Institute of Technology, University of Pune, India, in August, 1995. Completed the requirements for the Master of Science Degree with a major in Mechanical Engineering at Oklahoma State University in May, 1999.

Experience: Worked with Mahindra and Mahindra Ltd. (Automotive Sector), Bombay, India, in capacity of a Junior Design Engineer from 1995 to 1997. Worked with Eaton Corporation (Supercharger Division), Athens, Georgia, as a Summer Intern from June 1998 to August 1998. Worked in Web Handling Research Center (WHRC), Oklahoma State University, Stillwater, as a Research Assistant from August 1997 to Present.

Honors: Won "The Most Industrially Relevant Project of the Year" in 1995 for design and manufacture the "Dynamic Rubber Testing Machine". The project was guided and supported by National Engineering Company, Pune, India. The award was sponsored by Forbes Marshall.