

NUTRIENT DISTRIBUTION FOLLOWING APPLICATION  
OF SWINE EFFLUENT THROUGH A SUBSURFACE  
DRIP IRRIGATION SYSTEM

By

LISA FULTZ

Bachelor of Science in Agricultural Science and Natural Resources

Environmental Sciences

Oklahoma State University

Stillwater, Oklahoma

2004

Submitted to the Faculty of the  
Graduate College of the  
Oklahoma State University  
in partial fulfillment of  
the requirements for  
the Degree of  
MASTER OF SCIENCE  
May, 2009

NUTRIENT DISTRIBUTION FOLLOWING APPLICATION  
OF SWINE EFFLUENT THROUGH A SUBSURFACE  
DRIP IRRIGATION SYSTEM

Thesis Approved:

Dr. Jeffory Hattey

---

Thesis Adviser

Dr. Shiping Deng

---

Dr. Michael Kizer

---

Dr. A. Gordon Emslie

---

Dean of the Graduate College

## ACKNOWLEDGMENTS

I would like to express my deepest gratitude to Dr. Jeffory Hattey, my major advisor, for his encouragement, supervision, and most importantly his confidence in me. I would also like to thank my committee members Dr. Shiping Deng and Dr. Michael Kizer for all their support and guidance. I would like to thank Clemn Turner, Shawna Loper, Crystal Hanks, and Samantha Lofton for all their help and encouragement in the field and the lab, and whose presence ensured completion of my study, and that I remembered to enjoy every part of the process.

I would like to thank the staff at the Oklahoma Panhandle Research and Extension Center for their assistance and support. I would also like to offer thanks to the Oklahoma State University Plant and Soil Sciences Department for the use of their facilities and equipment as well as their continued support.

I also owe my parents, Suzan and Gerald Davis, and Doug Fultz, and my friends my sincerest gratitude for their support, encouragement, and love.

## TABLE OF CONTENTS

Chapter	Page
I. Introduction .....	1
a. Aquifer Use in Southern High Plains.....	4
b. Swine Production .....	5
c. Water and Water Soluble Nutrient Movement.....	6
d. Lysimeters .....	9
e. Objectives and Hypothesis.....	12
II. Materials and Methods .....	13
a. Site.....	13
b. Lysimeters .....	14
c. Lysimeter Placement .....	17
d. Sampling Procedure .....	20
e. Sample Analysis .....	21
III. Results and Discussion .....	22
a. Background Concentrations .....	22
b. Water Movement.....	25
c. Nitrogen.....	27
d. Orthophosphate .....	36
e. Calcium .....	42
f. Copper .....	48
g. Zinc .....	56
IV. Conclusions.....	64
V. References.....	66

VI. Appendices .....	71
a. Raw Solution Data – 14 May 2006 .....	72
b. Raw Solution Data – 7 June 2006 .....	73
c. Ammonium-N Concentration on 7 June 2007 at 0.72 L h <sup>-1</sup> .....	74
d. Ammonium-N Concentration on 7 June 2006 at 2.38 L h <sup>-1</sup> .....	75
e. Nitrate-N Concentration on 7 June 2006 at 0.72 L h <sup>-1</sup> .....	76
f. Nitrate-N Concentration on 7 June 2006 at 2.38 L h <sup>-1</sup> .....	77
g. Orthophosphate Concentration on 7 June 2006 at 0.72 L h <sup>-1</sup> .....	78
h. Orthophosphate Concentration on 7 June 2006 at 2.38 L h <sup>-1</sup> .....	79
i. Calcium Concentration on 7 June 2006 at 0.72 L h <sup>-1</sup> .....	80
j. Calcium Concentration on 7 June 2006 at 2.38 L h <sup>-1</sup> .....	81
k. Copper Concentration on 7 June 2006 at 0.72 L h <sup>-1</sup> .....	82
l. Copper Concentration on 7 June 2006 at 2.38 L h <sup>-1</sup> .....	83
m. Zinc Concentration on 7 June 2006 at 0.72 L h <sup>-1</sup> .....	84
n. Zinc Concentration on 7 June 2006 at 2.38 L h <sup>-1</sup> .....	85
o. Raw Solution Data – 21 June 2006 .....	86
p. Ammonium-N Concentration on 21 June 2006 at 0.72 L h <sup>-1</sup> .....	87
q. Ammonium-N Concentration on 21 June 2006 at 2.38 L h <sup>-1</sup> .....	88
r. Nitrate-N Concentration on 21 June 2006 at 0.72 L h <sup>-1</sup> .....	89
s. Nitrate-N Concentration on 21 June 2006 at 2.38 L h <sup>-1</sup> .....	90
t. Orthophosphate Concentration on 21 June 2006 at 0.72 L h <sup>-1</sup> .....	91
u. Orthophosphate Concentration on 21 June 2006 at 2.38 L h <sup>-1</sup> .....	92
v. Calcium Concentration on 21 June 2006 at 0.72 L h <sup>-1</sup> .....	93
w. Calcium Concentration on 21 June 2006 at 2.38 L h <sup>-1</sup> .....	94
x. Copper Concentration on 21 June 2006 at 0.72 L h <sup>-1</sup> .....	95
y. Copper Concentration on 21 June 2006 at 2.38 L h <sup>-1</sup> .....	96
z. Zinc Concentration on 21 June 2006 at 0.72 L h <sup>-1</sup> .....	97
aa. Zinc Concentration on 21 June 2006 at 2.38 L h <sup>-1</sup> .....	98
bb. Raw Solution Data – 26 July 2006 .....	99
cc. Raw Solution Data – 9 August 2006 .....	100
dd. Orthophosphate Concentration on 9 August 2006 at 0.72 L h <sup>-1</sup> .....	101
ee. Orthophosphate Concentration on 9 August 2006 at 2.38 L h <sup>-1</sup> .....	102
ff. Calcium Concentration on 9 August 2006 at 0.72 L h <sup>-1</sup> .....	103
gg. Copper Concentration on 9 August 2006 at 0.72 L h <sup>-1</sup> .....	104
hh. Zinc Concentration on 9 August 2006 at 0.72 L h <sup>-1</sup> .....	105

## LIST OF TABLES

Tables	Page
1. Average( $\pm$ SD) pH values, concentrations of selected nitrogen, phosphorus, trace elements, and EC content in acidified and non-acidified swine effluent used for application prior to filtration and application. Average data includes samples obtained from 2006-2008 effluent applications.....	23
2. Element concentration and pH (avg $\pm$ SD, mg L <sup>-1</sup> ) in soil solution on May 14 <sup>th</sup> , 2006 for emitter application rates of 2.38 and 0.72 L h <sup>-1</sup> averaged by depth.....	24

## LIST OF FIGURES

Figure	Page
1. Layout of large subsurface drip irrigation plots located at OPREC used for demonstration.....	14
2. Materials used for lysimeter construction seen in part a included A.) a porous ceramic cup, B.) a length of polyethylene tubing, C.) a fitting, and D.)PVC pipe with cap attached. Part B depicts fully constructed lysimeters consisting of a ceramic cup, PVC pipe, cap and fitting. Figure illustrates relative size for 4 depths measured.....	16
3. Basic lysimeter layout for each rep. Each letter, A, B, C, and D, indicates a depth of 15 cm, 30 cm, 45 cm, or 60 cm which were randomly assigned for each rep. Center of diagram represents location of subsurface drip tape with emitters marked with black squares.....	18
4. Three dimensional image showing location of ceramic cups of each lysimeter for the a.) inlet end of irrigation tapes with discharge rate of 2.38 L h <sup>-1</sup> and the b.) inlet end of irrigation tapes with discharge rate of 0.72 L h <sup>-1</sup> .Line located at the center of each figure indicates that location of the irrigation tape with asterisks marking each emitter.....	19
5. Ammonium-N concentration (mg L <sup>-1</sup> ) on 14 May 2006 from 0.72 L h <sup>-1</sup> emitter application rate at the depth of 30 cm. Background concentration prior to first effluent application event. Black line located at zero distance from the irrigation tape indicates location of irrigation tape with respect to the x-axis.....	29
6. Ammonium-N concentration (mg L <sup>-1</sup> ) on 26 July 2006 from 0.72 L h <sup>-1</sup> application rates at the depth of 30 cm. At 60 cm depth solution samples were obtained from limited lysimeters resulting in an incomplete graph. No solution was obtained from lysimeters located at 15 cm depth. Black line located at zero distance from the irrigation tape indicates location of irrigation tape with respect to the x-axis.....	29
7. Ammonium-N concentration (mg L <sup>-1</sup> ) on 14 May 2006 from 2.38 L h <sup>-1</sup> emitter application rate at depths of a.) 15 cm, b.) 30 cm, c.) 45 cm, and d.) 60 cm. Black line located at zero distance from the irrigation tape indicates location of irrigation tape with respect to the x-axis.....	30

8.	Ammonium-N concentration ( $\text{mg L}^{-1}$ ) on 26 July 2006 from $2.38 \text{ L h}^{-1}$ emitter application rates at the depth of 60 cm. At 60 cm depth solution samples were obtained from limited lysimeters resulting in an incomplete graph. No solution was obtained from lysimeters located at 15, 30, and 45 cm depth. Black line located at zero distance from the irrigation tape indicates location of irrigation tape with respect to the x-axis.....	31
9.	Nitrate-N concentration ( $\text{mg L}^{-1}$ ) on 14 May 2006 from $0.72 \text{ L h}^{-1}$ emitter application rate at depths of a.) 15 cm, b.) 30 cm, c.) 45 cm, and d.) 60 cm. At 45 cm depth solution samples were obtained from limited lysimeters resulting in an incomplete graph. Black line located at zero distance from the irrigation tape indicates location of irrigation tape with respect to the x-axis.....	32
10.	Nitrate-N concentration ( $\text{mg L}^{-1}$ ) on 26 July 2006 from $0.72 \text{ L h}^{-1}$ emitter application rate at depths of a.) 30 cm, b.) 45 cm, and c.) 60 cm. At 60 cm depth solution samples were obtained from limited lysimeters resulting in an incomplete graph. No solution was obtained from lysimeters located at 15 cm depth. Black line located at zero distance from the irrigation tape indicates location of irrigation tape with respect to the x-axis.....	33
11.	Nitrate-N concentration ( $\text{mg L}^{-1}$ ) on 14 May 2006 from $2.38 \text{ L h}^{-1}$ emitter application rates at depths of a.) 15 cm, b.) 30 cm, c.) 45 cm, and d.) 60 cm. Black line located at zero distance from the irrigation tape indicates location of irrigation tape with respect to the x-axis.....	34
12.	Nitrate-N concentration ( $\text{mg L}^{-1}$ ) on 26 July 2006 from $2.38 \text{ L h}^{-1}$ emitter application rates at the depth of 60 cm. At 60 cm depth solution samples were obtained from limited lysimeters resulting in an incomplete graph. No solution was obtained from lysimeters located at 15, 30, and 45 cm depth. Black line located at zero distance from the irrigation tape indicates location of irrigation tape with respect to the x-axis.....	35
13.	Orthophosphate concentration ( $\text{mg L}^{-1}$ ) on 14 May 2006 from $0.72 \text{ L h}^{-1}$ emitter application rate at depths of a.) 15 cm, b.) 30 cm, and c.) 60 cm. No solution was obtained from lysimeters located at 45 cm depth. At 30 cm depth solution samples were obtained from limited lysimeters resulting in an incomplete graph. Black line located at zero distance from the irrigation tape indicates location of irrigation tape with respect to the x-axis.....	38
14.	Orthophosphate concentration ( $\text{mg L}^{-1}$ ) on 26 July 2006 from $0.72 \text{ L h}^{-1}$ emitter application rate at depths of a.) 30 cm, b.) 45 cm, and c.) 60 cm. No solution was obtained from lysimeters located at 15 cm depth. At 60 cm depth solution samples were obtained from limited lysimeters resulting in an incomplete graph. Black line located at zero distance from the irrigation tape indicates location of irrigation tape with respect to the x-axis.....	39



15. Orthophosphate concentration ( $\text{mg L}^{-1}$ ) on 14 May 2006 from $2.38 \text{ L h}^{-1}$ emitter application rate at depths of a.) 15 cm, b.) 30 cm, c.) 45 cm, and d.) 60 cm. At 15 cm depth solution samples were obtained from limited lysimeters resulting in an incomplete graph. Black line located at zero distance from the irrigation tape indicates location of irrigation tape with respect to the x-axis.....	40
16. Orthophosphate concentration ( $\text{mg L}^{-1}$ ) on 26 July 2006 from $2.38 \text{ L h}^{-1}$ emitter application rate at depths of a.) 15 cm, b.) 45 cm, c.) 60 cm. No solution was obtained from lysimeters located at 30 cm depth. At 15, 45, and 60 cm depth solution samples were obtained from limited lysimeters resulting in an incomplete graph. Black line located at zero distance from the irrigation tape indicates location of irrigation tape with respect to the x-axis.....	41
17. Calcium concentration ( $\text{mg L}^{-1}$ ) on 14 May 2006 from $0.72 \text{ L h}^{-1}$ emitter application rate at depths of a.) 15 cm, b.) 30 cm, and c.) 60 cm. No solution was obtained from lysimeters located at 45 cm depth. At 30 cm depth solution samples were obtained from limited lysimeters resulting in an incomplete graph. Black line located at zero distance from the irrigation tape indicates location of irrigation tape with respect to the x-axis.....	44
18. Calcium concentration ( $\text{mg L}^{-1}$ ) on 26 July 2006 from $0.72 \text{ L h}^{-1}$ emitter application rate at depths of a.) 30 cm, b.) 45 cm, c.) 60 cm, and d.) 60 cm. No solution was obtained from lysimeters located at 15 cm depth. At 60 cm depth solution samples were obtained from limited lysimeters resulting in an incomplete graph. Black line located at zero distance from the irrigation tape indicates location of irrigation tape with respect to the x-axis.....	45
19. Calcium concentration ( $\text{mg L}^{-1}$ ) on 14 May 2006 from $2.38 \text{ L h}^{-1}$ emitter application rate at depths of a.) 15 cm, b.) 30 cm, c.) 45 cm, and d.) 60 cm. At 15 and 30 cm depth solution samples were obtained from limited lysimeters resulting in an incomplete graph. Black line located at zero distance from the irrigation tape indicates location of irrigation tape with respect to the x-axis.....	46
20. Calcium concentration ( $\text{mg L}^{-1}$ ) on 26 July 2006 from $2.38 \text{ L h}^{-1}$ emitter application rate at depths of a.) 15 cm and b.) 60 cm. No solution was obtained from lysimeters located at 30 and 45 cm depth no figures were produced. At 15 and 60 cm depth solution samples were obtained from limited lysimeters resulting in an incomplete graph. Black line located at zero distance from the irrigation tape indicates location of irrigation tape with respect to the x-axis.....	47

21. Copper concentrations ( $\text{mg L}^{-1}$ ) on dates of effluent application by depth at emitter application rate of $0.72 \text{ L h}^{-1}$ for lysimeters a.) 15 cm and b.) 30 cm from the irrigation tape.....	50
22. Copper concentration ( $\text{mg L}^{-1}$ ) on 14 May 2006 from $0.72 \text{ L h}^{-1}$ emitter application rate at the depth of 60 cm. No solution was obtained from lysimeters located at 45 cm depth. At 30 cm depth solution samples were obtained from limited lysimeters resulting in an incomplete graph. Black line located at zero distance from the irrigation tape indicates location of irrigation tape with respect to the x-axis.....	51
23. Copper concentration ( $\text{mg L}^{-1}$ ) on 26 July 2006 from $0.72 \text{ L h}^{-1}$ emitter application rate at depths of a.) 30 cm, b.) 45 cm, and c.) 60 cm. No solution was obtained from lysimeters located at 15 cm depth. At 60 cm depth solution samples were obtained from limited lysimeters resulting in an incomplete graph. Black line located at zero distance from the irrigation tape indicates location of irrigation tape with respect to the x-axis.....	52
24. Copper concentrations ( $\text{mg L}^{-1}$ ) on dates of effluent application by depth at emitter application rate of $2.38 \text{ L h}^{-1}$ for lysimeters a.) 20 cm and b.) 40 cm from the irrigation tape.....	53
25. Copper concentration ( $\text{mg L}^{-1}$ ) on 14 May 2006 from $2.38 \text{ L h}^{-1}$ emitter application rate at the depth of 60 cm. Black line located at zero distance from the irrigation tape indicates location of irrigation tape with respect to the x-axis.....	54
26. Copper concentration ( $\text{mg L}^{-1}$ ) on 26 July 2006 from $2.38 \text{ L h}^{-1}$ emitter application rate at depths of a.) 15 cm and b.) 60 cm. No solution was obtained from lysimeters located at 30 and 45 cm depth no figures were produced. At 15 and 60 cm depth solution samples were obtained from limited lysimeters resulting in an incomplete graph. Black line located at zero distance from the irrigation tape indicates location of irrigation tape with respect to the x-axis.....	55
27. Zinc concentration ( $\text{mg L}^{-1}$ ) on 14 May 2006 from $0.72 \text{ L h}^{-1}$ emitter application rate at depths of a.) 15 cm, b.) 30 cm and c.) 60 cm. No solution was obtained from lysimeters located at 45 cm depth. At 30 cm depth solution samples were obtained from limited lysimeters resulting in an incomplete graph. Black line located at zero distance from the irrigation tape indicates location of irrigation tape with respect to the x-axis.....	58

28. Zinc concentration ( $\text{mg L}^{-1}$ ) on 26 July 2006 from $0.72 \text{ L h}^{-1}$ emitter application rate at depths of a.) 30 cm, b.) 45 cm, and c.) 60 cm. No solution was obtained from lysimeters located at 15 cm depth. At 60 cm depth solution samples were obtained from limited lysimeters resulting in an incomplete graph. Black line located at zero distance from the irrigation tape indicates location of irrigation tape with respect to the x-axis.....	59
29. Zinc concentrations ( $\text{mg L}^{-1}$ ) on dates of effluent application by depth at emitter application rate of $0.72 \text{ L h}^{-1}$ for lysimeters a.) 15 cm and b.) 30 cm from the irrigation tape.....	60
30. Zinc concentration ( $\text{mg L}^{-1}$ ) on 14 May 2006 from $2.38 \text{ L h}^{-1}$ emitter application rate at depths of a.) 15 cm, b.) 30 cm, c.) 45 cm, and d.) 60 cm. At 15 and 30 cm depth solution samples were obtained from limited lysimeters resulting in an incomplete graph. Black line located at zero distance from the irrigation tape indicates location of irrigation tape with respect to the x-axis.....	61
31. Zinc concentration ( $\text{mg L}^{-1}$ ) on 26 July 2006 from $2.38 \text{ L h}^{-1}$ emitter application rate at depths of a.) 15 cm and b.) 60 cm. No solution was obtained from lysimeters located at 30 and 45 cm depth no figures were produced. At 15 and 60 cm depth solution samples were obtained from limited lysimeters resulting in an incomplete graph. Black line located at zero distance from the irrigation tape indicates location of irrigation tape with respect to the x-axis.....	62
32. Zinc concentrations ( $\text{mg L}^{-1}$ ) on dates of effluent application by depth at emitter application rate of $2.38 \text{ L h}^{-1}$ for lysimeters a.) 20 cm and b.) 40 cm from the irrigation tape.....	63

## INTRODUCTION

“Thus, analysis of soil solution composition is frequently more instructive than is analysis of whole soils or soil extracts.

-Jeff Wolt (1994)

The American Society of Agricultural and Biological Engineers define subsurface drip irrigation (SDI) as the “application of water below the soil surface through emitters, with discharge rates generally in the same range as drip irrigation” (Camp, 1998).

Subsurface drip irrigation systems have been utilized since the 1920s, however systems similar to those used today were not developed until the late 1940s (Camp, 1998).

During the 1970s SDI systems attracted scientist attention as well as producers driving technological growth. Initial work was done in Israel where limited water supplies required development of irrigation methods that enhanced water use efficiency for agricultural production (Oron et al., 1991). Current SDI systems are purported to be up to 95 % efficient at supplying water to the root zone as compared to more popular systems such as center pivot and surface drip irrigation with reported efficiencies of 70 and 90 % respectively.

Lamm (2002) stated that SDI allows for an increase in water use efficiency, the ability to use degraded water, a lower risk of contamination reaching other water sources, and a more homogeneous application of water. Several studies done in Israel have shown that contamination of produce from waste water is negligible when the waste is applied

through SDI systems (Shelef, 1991; Oron et al., 1992; Oron, 1996; Campos et al., 2000).

Lamm (2002) discussed advantages and disadvantages of using subsurface drip irrigation systems which were grouped into three categories; water or soil issues, cropping or cultural practices, and system infrastructure. For water or soil issues SDI provides several advantages including water use efficiency by reducing soil evaporation, surface runoff, or deep percolation while improving infiltration and water storage. Proper utilization of a system can partially eliminate evaporation from the soil surface and decrease the number of weeds present. The use of SDI also provides uniform application of irrigation or fertilization within the field and allows for use of waste waters while decreasing the risk of contact and contamination at the surface.

Evaluation of advantages associated with cropping cultural practices has shown that yields and crop quality have improved in several irrigation systems. Fertigation, the application of fertilizer with irrigation water, is also a common practice associated with SDI systems. In this practice, fertilizers are applied in the root zone where they are most needed by plants without coming in contact with crop canopy or the soil surface (Haynes, 1985). This, in turn, makes it possible for improvements in weed control and overall improvements in management of a production facility.

Advantages associated with system infrastructure include the likelihood for automation allowing for fewer individuals required to operate and maintain the system. Subsurface drip irrigation systems can be more versatile than more common systems such as center pivots which allow for multiple designs to fit the shape of any given fields while systems such as center pivot are capable of covering only a predefined circular area. The use of subsurface drip irrigation also allows equipment access to the field during

irrigation events, as the surface is dryer and no equipment is located on the surface.

Disadvantages to be considered when examining the usefulness of a SDI system include site characteristics where a system is being installed. In areas with coarse textured soils the wetting pattern may not be sufficiently distributed for crop production. In areas where the systems exceed the soils ability to distribute the water evenly a chimney effect or surfacing may occur placing humans and other organisms in direct contact with waste water or to downward movement of contaminants to groundwater sources (Ben-Gal and Lazarovitch, 2003). The location of irrigation tapes below the surface is disadvantageous as it is difficult to monitor the system for uniform application as well as locating and repairing any problem areas such as leaks, breaks, or clogs in the system. Tillage practices are also limited based on the depth at which a system is placed because it is possible to damage an irrigation tape during cultivation. In areas inhabited by large populations of burrowing animals potential exists for damage to occur to the irrigation tapes.

Other issues which require further examination include the use of subsurface systems for seed germination. However, as surfacing should not occur in a properly designed system, another irrigation method may be required to establish a crop before subsurface systems can be utilized. Charlesworth and Muirhead (2003) found that subsurface systems would require more water than most sprinkler systems for plant establishment. However, they also found that in their particular location sufficient surfacing was produced to assist in the establishment of the crop. While it was possible for establishment to occur using subsurface systems water use efficiency was reduced during the establishment period. Potentially the most prohibitive disadvantage for a

subsurface system is the initial cost which includes installation and maintenance. High input cost in areas where adequate water is not always available may preclude the ultimate usefulness of the system.

### **Aquifer Use in Southern High Plains**

The Southern High Plains region includes Cimarron, Texas, and Beaver counties in the Oklahoma Panhandle which overlay the High Plains, or Ogallala Aquifer that serves as the primary water source. This region receives between 380 to 560 mm of precipitation per year resulting in limited surface water sources for agricultural production. The lack of adequate water supply requires producers to utilize alternatives to supplement current water sources. The Ogallala Aquifer, a non-renewable water source, supplies over 90 % of the water used to irrigate approximately one fifth of U.S. cropland (Guru and Horne, 2000). As early as 1920 farmers were digging shallow wells to access groundwater for irrigation, but in 1931 during a particularly dry period, deeper wells were required by producers not fortunate enough to be located in flood plains of the region. As of 1984, underground wells in Texas County were reported to supply irrigation water for nearly 20,234 hectares (50,000 acres). Specifically Texas County was reported to use approximately 957,870 m<sup>3</sup> (254 million gallons) of water per day from groundwater sources for irrigation (USGS, 2000). However, the continual withdrawal of groundwater is cause for concern as recharge rates average only 25 mL a year to replace the dwindling supply of water (Kromm, 2007). For this reason, producers are looking to alternate sources such as effluent from local animal producers to supplement irrigation needs.

## **Swine Production**

Swine production is a common practice enlisted in many of the states considered to be part of the Cornbelt as well as those states located along its outer edge, including Oklahoma. The National Agricultural Statistical Service (NASS), the January 2004 report estimates 2,340,000 pigs and hogs in the state of Oklahoma, of which 1,490,000 were located in three counties (Cimarron, Texas, and Beaver) and are all located in the panhandle. Swine effluent accounts for approximately 12 to 15% of the total livestock waste produced in this area (Brumm, 1998). Most swine production systems in this region utilize anaerobic lagoons to digest the solid waste and allow it to be handled as a liquid (Karlen et al., 1998). This process allows for 70 to 90% of the N in waste to be volatilized; however there still exists the possibility for N and P to reach ground or surface waters. Brumm (1998) stated that the number of producers moving towards confined production requiring the use of lagoons to treat manure produced on site was increasing. Increased confinement has led to increased requirements for dietary supplements (NRC, 1998). While supplementing helps produce healthier animals, there is an accounting for the increased concentrations of nutrients and trace elements such as Cu, Zn, and Cr produced on site. To mitigate this dilemma several producers land apply effluent as a source for either a solid fertilizer or utilize the liquid for irrigation. However, continuous applications have led to the accumulation of nutrients and trace metals in soil profiles and then become susceptible to leaching or erosion into local water bodies. Many of the problems associated with utilization of animal waste are a direct result of elevated concentrations of nutrients including N, P, Ca, Cu, and Zn, in swine diets.



Supplements added to increase dietary intake often cause excess nutrients in the waste produced. Soybeans are added to increase quantities of amino acids and also supply excess lysine which increases N concentrations in the effluent. Synthetic lysine has been shown to decrease the amount of soybean required. The lack of phytase enzyme allows animals access to only 10 to 15 % and 25 % of phytate found in corn and soybean respectively (Brumm, 1998). Low phytate corn has been shown to decrease levels of P excreted but is not currently economically feasible for farmers to produce. However the addition of phytase enzyme to feed has shown to decrease quantities of P excreted by 30 to 60 % (NRC, 1998). Zinc, Cu, and Ca are also added as supplements to improve growth rates of swine; however concentrations often exceeded animal requirement resulting in larger amounts excreted through the waste.

### **Water and Water Soluble Nutrient Movement**

Movement of water and nutrients through the soil is a function of soil's saturated hydraulic conductivity, the rate at which water is discharged, and amount of time the system is allowed to operate (Haynes, 1990). Bar-Yosef and Sheikholslami (1979) found that while water discharged from a point source moved through soil symmetrically, sandy soils exhibited more vertical movement than was found in clayey soils. Increasing the discharge rate resulted in more horizontal movement while decreasing discharge rate produced more upward movement (Haynes, 1990; Li et al., 2003, Li et al., 2004). Li et al. (2003) also found that increasing the volume of water increased the depth to which water moved.

Nutrient movement is also a function of the soils cation exchange capacity (CEC)

and its current nutrient status. Soils with high CEC's are able to adsorb larger quantities of positively charged ions, while soils with lower CEC's do not adsorb nutrients and leaching is more likely to occur. Nutrient distribution is also highly dependent on the form in which it is applied as is the case of N. Haynes (1990) found that  $\text{NH}_4^+$ -N concentrations increased directly below drip irrigation emitters while  $\text{NO}_3^-$  and urea were more evenly distributed throughout the profile. However, Li et al. (2004) also found that  $\text{NO}_3^-$ -N tended to accumulate at the wetting front regardless of when the fertilizer application occurred, due to the decrease in water content with respect to  $\text{NO}_3^-$  concentrations. Cases of denitrification were found directly below emitters of surface trickle irrigation due to the reducing environment which result from saturated conditions. This decreases the losses of N through  $\text{NO}_3^-$  leaching. The reducing conditions also decrease the rate of nitrification allowing N to remain in the form of  $\text{NH}_4^+$  thus decreasing losses.

Orthophosphate distribution is dependent on the phosphate adsorption capacity of the soil (Haynes, 1985). The concept that P is immobile within the soil leads to the assumption that P applied through an irrigation system will not move far beyond the point of discharge resulting in decreased concentrations in soil solution with increased distance from the application point. Bar-Yosef and Sheikholislami (1979) found that in a clayey soil, phosphate concentrations were highest close to the application source with little vertical movement when using surface trickle irrigation, supporting this theory. However, several studies (Rauschkolb et al., 1976; Bacon and Davey, 1982; Ben-Gal and Dudley, 2003) found that P movement increased when applied through drip irrigation. Ben-Gal and Dudley (2003) state that increased moisture and irrigation frequency

increased P mobility and availability indicated by increased concentrations of P within the plant material under continuous irrigation. Bacon and Davey (1982) found that P availability was cyclic based on the irrigation frequency for a given site. Increased P solubility following irrigation cycles may have been due to reducing conditions which formed under saturated conditions. The anoxic environment resulted in the reduction of ferrous iron associated with naturally occurring phosphate to ferric iron releasing the phosphate. This release of phosphate may explain the lower than expected concentrations of phosphate closer to the irrigation emitters.

In the case of calcium, copper, and zinc, each is selectively removed from solution and retained by various soil constituents including CEC and mineral content. Calcium is common in arid environments due to low rainfall and typically found in the form of calcite ( $\text{CaCO}_3$ ), Dolomite ( $\text{CaMg}(\text{CO}_3)_2$ ), and gypsum ( $\text{CaSO}_4$ ). Calcium is readily removed from soil solution by electrostatic forces (CEC) but dependent on the ions present in solution. High concentrations of calcium in solution can saturate exchange sites resulting in little initial movement of calcium from the application point. Soil copper concentrations range from 1 to 40  $\text{mg L}^{-1}$ , while soil solution concentrations typically range from  $10^{-8}$  to  $10^{-6}$  M (Havlin et al., 1999). Copper availability is determined predominantly by solution pH with soil solution concentrations remaining very low. Copper is one of the most strongly sorbed divalent metals on iron and aluminum oxides and is chemically adsorbed by layer silicates again resulting in increased concentrations at application points. Globally, zinc concentrations within the soil typically range between 10 and 300  $\text{mg L}^{-1}$  while zinc concentrations in soil solution ranges between 0.002 and 0.07  $\text{mg L}^{-1}$  (Havlin et al., 1999). Zinc availability is also

determined by pH, decreasing as pH becomes more alkaline. It is capable of forming stable complexes with SOM components, becoming immobilized by high molecular weight organic substances (lignin) and forming complexes with soluble organic substances resulting in insoluble salts. In the presence of short-chain organic acids and bases, zinc becomes soluble and mobile within soil solution.

### **Lysimeters**

In Litaor's (1988) review of soil solution sampling the discussion focuses on the methodology utilized in previous studies. The basic premise of soil solution sampling has not changed, however paraphernalia has gone through several modifications. Basic suction lysimeters are composed of a porous cup, a sample storage area, and tubing which allows for removal of solution (Parizek and Bell, 1970). Final design and dimensions are based on the requirements for the experiment. Lysimeter placement must be done with the greatest care to avoid introducing conditions dissimilar to surrounding areas. Initial suction lysimeters were constructed using porous ceramic cups, which are still being used today. New cup materials available include alundum, glass fiber, and Teflon each with its own advantages and disadvantages. Suction methodology is also an important issue under much debate.

Different materials offer many solutions to various concerns associated with solution sampling. Porous ceramic cups are believed to be problematic when sampling for constituents including certain forms of P and N, and those materials which may be found in the ceramic used. Proper preparation, done prior to placement, has been shown to reduce the negative effects associated with use of ceramic cups. Glass fiber lysimeters

have been shown to have little effect on the chemistry of soil solution; however they must be handled with extreme care. The fragility of glass fiber and alundum lysimeters makes them ill fitted for use in agriculturally active fields as well as in areas in which the ground may experience freezing conditions resulting in broke cups. Teflon, also shown to have little effect on the chemistry of the soil solution, can have problems producing adequate samples in an unsaturated zone.

Hansen and Harris (1975) discuss the use of porous ceramic cup lysimeters citing two methods of vacuum use which may account for some of the variations found in results. Specifically, the concept of a falling vacuum method is introduced. In this method a vacuum is placed on the lysimeter; the lysimeter is sealed and allowed to draw solution from the surrounding soil. Pressure within the lysimeter decreases as liquid is drawn into the cup until reaching equilibrium with the surrounding environment (Hansen & Harris, 1975). This method allows an adequate sample to be obtained over a given period of time without disturbing the site.

One method suggested to decrease the effects of the ceramic cup sorption on solution chemistry includes rinsing cups with an acid before placement in the field (Grover and Lamborn, 1970). However, these results were based on the cups available at the time of the study, thus may not hold true with current sources of porous ceramic cups. Grover and Lamborn (1970) examined the results of rinsing porous ceramic cups with either de-ionized water only or hydrochloric acid followed by water. While concentrations of Ca remained high, contamination of K and Na decreased significantly as did the effects of orthophosphate adsorption. McGuire et al. (1992) also found that acid washing produced lower absorption rates of trace metals when compared to water

rinsed samples. However they also found that decreased absorption rates occurred in lysimeters rinsed with only water after they had been pretreated or treated in the field with a sample containing low concentrations of constituents examined. Thus, by rinsing the cups with water and pre-treating them some of the damage associated with acid rinses can be avoided. These findings are supported by SoilMoisture documentation stating that due to changes in chemical composition of the ceramics used, acid washing was no longer recommended. Hansen and Harris (1975) stated that one source of discrepancy in the obtained solution may have resulted from variation in the ceramic cups used for sampling. Sorption of orthophosphates resulted in decreasing concentrations; however  $\text{NO}_3^-$ , susceptible to screening, did not seem to be affected.

Hornbuckle (2004) examined salt distribution associated within the same subsurface drip irrigation system. In this study eighteen core samples were removed from three treatments, allowed to dry, and were rewetted to remove extracts for analysis. No significant increases of Na, Ca, or Mg were found in the system after one year of collection. Analysis of samples from the field receiving the highest application rate ( $2.63 \text{ L h}^{-1}$ ) indicated an exaggeration of the concentrations due to the high rate flow from emitters. Analysis of samples from the field receiving the lowest application rate ( $0.73 \text{ L h}^{-1}$ ) indicated a large amount of gravitational flow leading to leaching through the profile with higher concentrations at lower depths. Samples taken following rainfall events showed no increase in movement down through the profile. A shallow caliche layer at a depth of 61 cm was believed to act as a confining layer which kept examined parameters within the root zone.

## Objectives and Hypothesis

As needs for agricultural production increase, production in less desirable environments becomes an increasing trend worldwide. With increased production comes the requirement for more plant needs including nutrients and water. In areas where excess nutrients and water are scarce, waste products, such as swine effluent, can serve as supplements for both moisture and nutrient requirements. However, with application of waste products comes the concern that mismanagement may lead to far reaching environmental impacts. Monitoring nutrient movement through the soil profile surrounding a SDI system provides producers with information needed to make management decisions.

The primary objective of this study was to examine the extent of nutrient transport following emission from a subsurface drip irrigation tape. Nutrients examined included  $\text{NO}_3^-$ -N,  $\text{NH}_4^+$ -N, orthophosphate (OP), Ca, Cu, and Zn at four depths within the soil profile. Understanding of nutrient movement will aid in the design and development when installing a SDI system as well as the use of alternative irrigation sources. This further aids in development of an irrigation method which would maximize economical benefits with enhanced crop production and minimal negative impact to the environment.

It is hypothesized that at emitter application rates of  $0.72 \text{ L h}^{-1}$  concentrations of  $\text{NO}_3^-$ -N,  $\text{NH}_4^+$ -N, orthophosphate, calcium, copper, and zinc will be uniformly distributed throughout the soil profile. At the  $2.38 \text{ L h}^{-1}$  emitter application rate,  $\text{NO}_3^-$ -N concentrations are hypothesized to increase with distance from the irrigation tape as the  $\text{NO}_3^-$ -N moves with the wetting front. Concentrations of  $\text{NH}_4^+$ -N, OP, Ca, Cu, and Zn are expected to be greatest near the irrigation tape at the point of application.

## MATERIALS AND METHODS

### Site

Located in Goodwell, Oklahoma, the Oklahoma Panhandle Research and Extension Center supplied research plots for the installation of SDI system described by Hornbuckle (2004). In this semi-arid ecosystem which receives on average only 447 mm of precipitation a year irrigation becomes an integral component of agriculture production operation. The dominant soil on the research station is a Richfield Clay Loam (Fine, smectitic, mesic *Aridic Argiustolls*), considered to be the most fertile soil in Texas County (SSS, 1984). This soil is less susceptible to runoff and is capable of storing large quantities of water; however, during heavy rain events it is susceptible to sheet erosion. Four larger plots (measuring 182.9 m by 18.3 m) were designed to simulate the different flow rates using swine effluent and provide visual demonstrations for local farmers (Figure 1). Flow rates range from the highest emitter flow rate of  $2.38 \text{ L h}^{-1}$  ( $0.63 \text{ gal h}^{-1}$ ) for the field designated 49-50 to the lowest emitter flow rate of  $0.72 \text{ L h}^{-1}$  ( $0.19 \text{ gal h}^{-1}$ ) for the field designated 53.



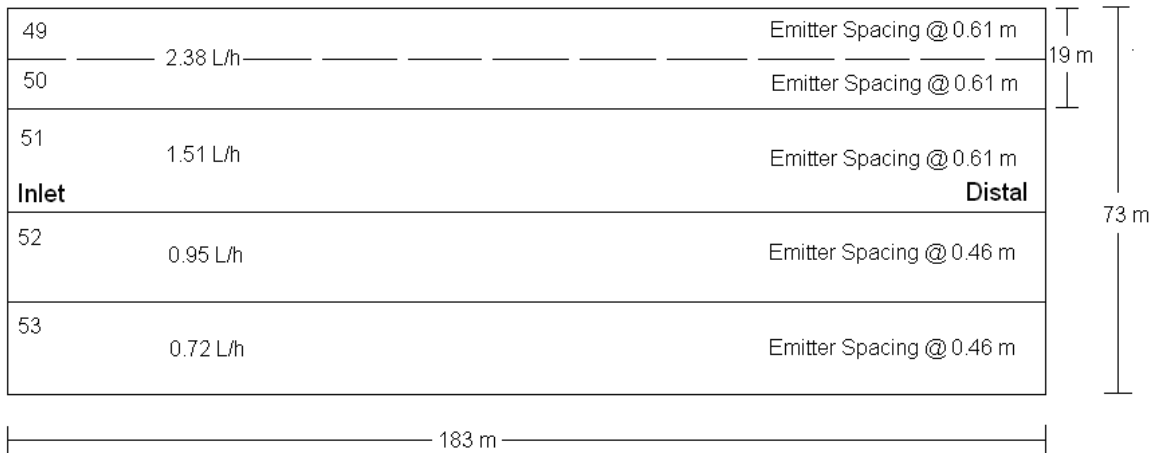

Figure 1. Layout of large subsurface drip irrigation plots located at OPREC used for demonstration.

The four larger plots are currently used for a corn/soybean rotation. In 2006 Corn (*Zea mays*) was grown on the field irrigated by irrigation tapes with an emitter discharge rate of 2.38 L h<sup>-1</sup>. The field utilizing an emitter discharge rate of 0.72 L h<sup>-1</sup> produced soybean (*Glycine max*). Effluent applications occurred on four occasions; June 6<sup>th</sup>, June 20<sup>th</sup>, July 26<sup>th</sup>, and August 9<sup>th</sup>. On average, the field utilizing the highest discharge rates required two hours and the field using the lowest discharge rate required eight hours for a complete effluent application, approximately 17 cubic meters. Supplemental irrigation, using groundwater, occurred daily, with fields on a rotational schedule. Beginning in 2006 sulfuric acid and urea sulfate were added at the rate of 0.004 cubic meter (1 gallon) per 22 cubic meters (5,400 gallons) of water added.

### Lysimeters

Following a similar design as used by Hansen and Harris (1975) as well as SoilMoisture, lysimeters were constructed using porous ceramic cups (SoilMoisture<sup>®\*</sup>), polyvinyl chloride (PVC) pipe, PVC caps, ¼ inch X ¼ inch barb to MIP adapter fittings,

and polyethylene tubing (Figure 2a). Three coats of epoxy supplied by SoilMoisture were used to seal the top rims of the cups as well as to ensure a proper fit within the PVC pipe, allowing for an air tight seal for creation of a vacuum. Polyvinyl chloride pipe was cut to length to allow for lysimeters at depths of 15, 30, 46, and 61 cm (6, 12, 18, and 24 inches). A hole was drilled into the end of each PVC cap into which a fitting was inserted and sealed with a silicone sealant. This fitting, located at the soil surface allowed for sample collection from the lysimeters. Epoxy was used to cement ceramic cups to the PVC pipe with a cap attached to the opposite end. Polyethylene tubing ran the length of the PVC pipe from the bottom of the fitting to the ceramic cup allowing for removal of solution samples. The barb fitting located at the top of the lysimeters was fitted with a length of tubing to allow for attachment to the manifold as well as sealing the lysimeters following sampling.

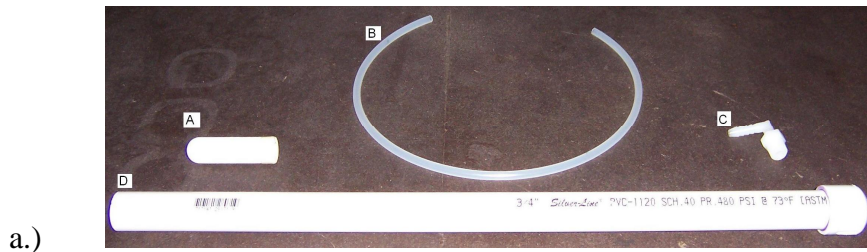

a.)



b.)

Figure 2. Materials used for lysimeter construction seen in part a.) included A.) a porous ceramic cup, B.) a length of polyethylene tubing, C.) a fitting, and D.)PVC pipe with cap attached. Part B depicts fully constructed lysimeters consisting of a ceramic cup, PVC pipe, cap and fitting. Figure illustrates relative size for 4 depths measured.

Completed lysimeters (Figure 2b) cured for 2 days to allow the epoxy to harden and ensure the silicone seals had set. A random sampling of ten ceramic cups were weighed to obtain a dry weight and then submerged in individual beakers containing 250 milliliters of de-ionized water for 72 hours. Ceramic cups were weighed to obtain their wet weight and pore volume was determined from the amount of water absorbed. Based on an average of 7.6 mL of pore space, 100 mL (15 pore volumes) were drawn through each completed lysimeter to remove any loose particles from within the lysimeters as well as within the ceramic cups. Additional lysimeters were tested prior to installation in the field by drawing a sample of de-ionized water through the cups. These samples were then analyzed to determine the concentration of potential contaminants which may have been the result of the ceramic cups.

## **Lysimeter Placement**

Two treatments based on flow rate from the emitters were chosen for this experiment. A group of 16 lysimeters were placed at each end (inlet and distal) of a single irrigation tape. The position of the emitter was determined by locating an emitter outside the study field and then measuring into the field to locate the appropriate set of emitters. These emitters were located within the area planted to include the effects of plant uptake in the measurements taken. Due to the disturbance caused when locating emitters this method was chosen to insure as little disturbance to the chosen area of study. Flags were used to mark the location of the irrigation tapes and the emitters to ensure they would be easily located when lysimeters were being placed. Upon transport to Goodwell, OK, lysimeters were placed in distilled water for 24 hours. The first row of lysimeters was placed in line with an emitter located within the area of planting.

All holes were drilled using a Giddings Hydraulic Probe to insure uniform opening sizes. The soil core from an individual hole was placed in a bucket, pulverized and wetted to create a slurry which ensured contact between the ceramic cup and the surrounding soil. The slurry was then placed in the hole, followed by the lysimeter and any remaining space was filled in with dry soil from the surface around the hole. Once a row of lysimeters were completed a cover (consisting of a piece of two inch PVC pipe sliced in half and painted orange) was placed over the fittings to protect the lysimeters and mark their location.

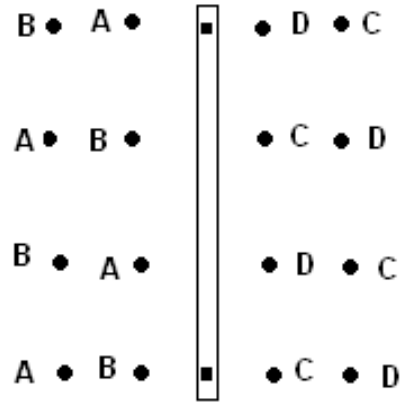

Figure 3. Basic lysimeter layout for each replication. Each letter, A, B, C, and D, indicates a depth of 15 cm, 30 cm, 45 cm, or 60 cm which were randomly assigned for each rep. Center of diagram represents location of subsurface drip tape with emitters marked with black squares.

The layout design (Figure 3) for lysimeters was developed to allow for randomized lysimeter placement and based on the assumption of uniform water movement through the soil profile from a subsurface drip irrigation source. It was determined that a total of sixteen lysimeters (Figure 3) would be used for each rep, with a total of 32 lysimeters per treatment. This arrangement allowed for sampling to occur at and between two emitters on a given irrigation tape, as well as at two distances from the irrigation tape. The depths and locations of each lysimeter followed a set pattern in which the depths were randomized to ensure that each depth was sampled at all possible locations between the emitters and away from the irrigation tape. Distance between each lysimeter was determined by the spacing between two adjacent emitters. For irrigation tape lines with an emitter rate of  $2.38 \text{ L h}^{-1}$  emitters were spaced 60 cm apart. To ensure equal area was measured by each lysimeter spacing was determined to be 20.32 from the irrigation tape and between each lysimeter. Irrigation tape lines with an emitter rate of  $0.72 \text{ L h}^{-1}$  and emitters spaced 46 cm apart required lysimeter spacing to be reduced to 15

cm. Figure 4 illustrates in three dimensions the placement of lysimeters for each of the four replications. Irrigation tape location is indicated by a black line through each image. Each asterisk indicated the location of a ceramic cup associated with a lysimeter located at depths of 15, 30, 45, or 60 cm.

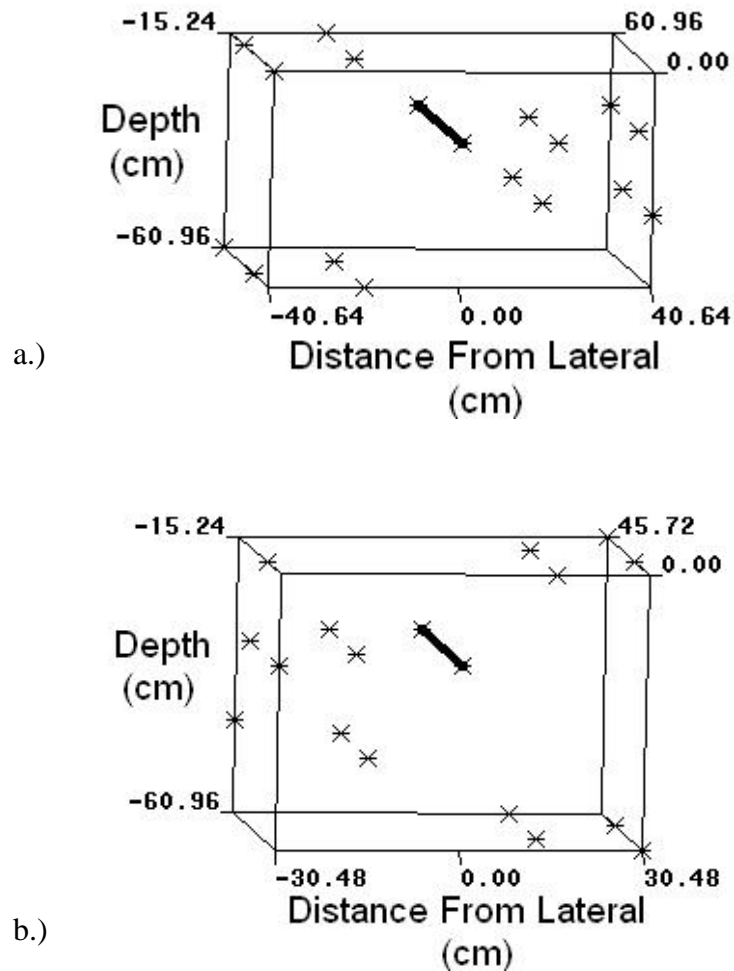

Figure 4. Three dimensional image showing location of ceramic cups of each lysimeter for the a.) inlet end of irrigation tapes with discharge rate of  $2.38 \text{ L h}^{-1}$  and the b.) inlet end of irrigation tapes with discharge rate of  $0.72 \text{ L h}^{-1}$ . Line located at the center of each figure indicates that location of the irrigation tape with asterisks marking each ceramic cup associated with a lysimeter.

## **Sampling Procedure**

Following placement of lysimeters, suction was placed on each lysimeter to allow the soil solution to pass through the ceramic cup. This was done to pre-condition the lysimeters before any soil solution was removed for analysis. To “pull” a sample from the lysimeter polyethylene tubing at the soil surface was attached to a fitting on the manifold which led to an individual collection bottle. A KNF Neuberger pump was used to create a vacuum within the collection bottle that in turn created a vacuum within the lysimeter and draw water from the surrounding soil profile. As water passed through the ceramic cup and entered the inner cavity of the lysimeter, the vacuum pressure within the lysimeter decreased until reaching equilibrium with the surrounding soil. A second vacuum was introduced approximately 24 hours following initial vacuum to remove the solution via the length of tube within the lysimeter. Any sample within the lysimeter was collected in collection bottles on the surface. When an adequate amount (approximately 40 mL) of sample had been collected, the vacuum was removed and the lysimeter was sealed until the next sampling event. The first samples were extracted in May of 2006 following an irrigation event but prior to any application of animal waste. This was done to collect concentrations of any background levels before wastewater was applied to the fields. Subsequent solution extractions were obtained at the time of effluent irrigation events on June 7<sup>th</sup>, June 21<sup>st</sup>, July 26<sup>th</sup>, and August 9<sup>th</sup>. Samples of swine effluent used for applications was obtained before reaching the filtering mechanism, acidified using sulfuric acid and transported to the laboratory for analysis.

## **Sample Analysis**

Electrical conductivity and pH were measured within 24 hours of removal using Vernier EC and pH probes with a handheld interface. Solution samples were acidified with sulfuric acid to preserve samples for transport. Samples were immediately refrigerated and transported to the laboratory for analysis. All samples were analyzed for  $\text{NO}_3^-$ -N,  $\text{NH}_4^+$ -N, and orthophosphate using a Lachat auto flow injection analyzer. Ca, Cu and Zn concentrations were obtained using inductively coupled argon plasma.



## RESULTS AND DISCUSSION

### Background Concentrations

Samples obtained from effluent prior to application served to provide concentrations (Table 1) of nutrients supplied via SDI. Analysis was determined to provide known concentrations of added nutrients.

Table 2 showed nutrient concentrations on May 14<sup>th</sup>, prior to initial effluent applications for the 2006 season. This data was used to examine potential increases beyond levels associated with the site resulting from effluent application. Nutrient concentrations following effluent applications (Appendices B, O, BB, and CC) were greater than those found in soil solution in all cases except calcium and nitrate-nitrogen ( $\text{NO}_3^-$ -N). This decrease is believed to result from the sorption of elements to soil particles as solution moves through the profile as well as plant uptake as the growing season progresses. The increase in  $\text{NO}_3^-$ -N may be the result of nitrification of ammonium occurring prior to obtaining solution samples is obtained. Increased calcium concentrations are likely due to high calcium associated with surrounding soil.

Table 1. Average ( $\pm$ SD) pH values, concentrations of selected nitrogen, phosphorus, trace elements, and EC content in acidified and non-acidified swine effluent used for application prior to filtration and application. Average data includes samples obtained from 2006-2008 effluent applications.

Date	pH	NO <sub>3</sub> <sup>-</sup> -N	NH <sub>4</sub> <sup>+</sup> -N	OP	Ca	Cu	Zn	EC
		-----mg L <sup>-1</sup> -----						dS m <sup>-1</sup>
17-May-06 <sup>*</sup>	8.60( $\pm$ 0.0)	525( $\pm$ 118.8)	698( $\pm$ 18.4)	30.80( $\pm$ 3.7)	41.01( $\pm$ 14.5)	1.14( $\pm$ 0.8)	7.83( $\pm$ 5.6)	8.3( $\pm$ 0.0)
n=	2	2	2	2	2	2	2	2
19-Jun-06 <sup>†‡</sup>	8.60	0.51	702.00	22.60	136.40	1.23	10.74	8.3
19-Jun-06 <sup>†§</sup>	8.60	0.34	707.00	40.00	131.40	1.22	10.36	8.3
Average <sup>‡</sup>	8.19( $\pm$ 0.4)	0.42( $\pm$ 0.1)	392.00( $\pm$ 253.3)	22.84( $\pm$ 4.7)	72.63( $\pm$ 42.7)	1.22( $\pm$ 1.1)	4.46( $\pm$ 4.2)	6.9( $\pm$ 1.1)
n=	4	3	3	4	4	4	4	4
Average <sup>§</sup>	8.18( $\pm$ 0.4)	0.47( $\pm$ 0.3)	385.3( $\pm$ 278.7)	28.02( $\pm$ 11.9)	78.4( $\pm$ 35.4)	1.61( $\pm$ 1.2)	4.36( $\pm$ 4.0)	6.8(1.1)
n=	4	3	3	4	4	4	4	4

\* Samples taken from single stage lagoon.

† Only one data point available for analysis resulting in no standard deviation.

‡ Samples were not acidified prior to analysis.

§ Samples were acidified prior to analysis.

Table 2. Element concentration and pH (avg±SD, mg L<sup>-1</sup>) in soil solution on 14 May 2006 for emitter application rates of 2.38 and 0.72 L h<sup>-1</sup> averaged by depth.

Emitter Rate	Depth	pH	NO <sub>3</sub> <sup>-</sup> -N	NH <sub>4</sub> <sup>+</sup> -N	OP	Ca	Cu	Zn	EC	
L h <sup>-1</sup>	cm		-----mg L <sup>-1</sup> -----							μS cm <sup>-1</sup>
2.38	15	8.1 (±0.4)	25.3 (±17.3)	0.4 (±0.6)	1.6 (±1.0)	90.2 (±22.0)	0.0 (±0.0) <sup>*</sup>	0.1 (±0.1)	1784.0 (±1163.0)	
	n=	4	4	4	3	3	3	3	3.0	
	30	8.5 (±0.3)	39.9 (±11.1)	0.4 (±0.4)	1.7 (±0.9)	165.8 (±38.6)	0.0 (±0.0) <sup>*</sup>	0.3 (±0.3)	2641.5 (±436.6)	
	n=	4	4	4	3	3	3	3	3	
	45	8.2 (±0.5)	29.8 (±24.2)	0.5 (±0.5)	1.6 (±0.2)	144.2 (±34.7)	0.0 (±0.0) <sup>*</sup>	0.5 (±0.6)	1541.0 (±525.6)	
	n=	4	4	4	3	3	3	3	3	
	60	8.2 (±0.1)	9.9 (±12.0)	0.7 (±1.3)	1.0 (±0.5)	123.8 (±20.1)	0.0 (±0.0) <sup>*</sup>	1.2 (±2.2)	2181.9 (±1018.9)	
	n=	4	4	4	4	4	4	4	4	
0.72	15	8.4 (±0.2)	20.6 (±14.0)	0.2 (±0.2)	1.6 (±0.1)	153.3 (±11.5)	0.0 (±0.0) <sup>*</sup>	0.3 (±0.2)	1173.9 (±62.6)	
	n=	4	4	4	4	4	4	4	4	
	30	8.4 (±0.3)	10.7 (±2.9)	0.0 (±0.0) <sup>*</sup>	1.7 (±0.6)	104.0 (±1.2)	0.0 (±0.0) <sup>*</sup>	0.1 (±0.0)	970.5 (±58.4)	
	n=	3	3	3	2	2	2	2	2	
	45	8.2 (±0.3)	26.3 (±10.5)	0.1 (±0.1)	1.0 <sup>†</sup>	112.5 <sup>†</sup>	0.0 <sup>†</sup>	0.1 <sup>†</sup>	1116.0 <sup>†</sup>	
	n=	2	2	2	1	1	1	1	1	
	60	7.8 (±0.0)	53.4 (±24.7)	0.2 (±0.3)	1.4 (±0.4)	168.9 (±39.7)	0.0 (±0.0) <sup>*</sup>	0.3 (±0.3)	1593.9 (±277.4)	
	n=	3	3	3	3	3	3	3	3	

\* Concentrations were below detection limits for analysis method.

† Standard Deviation not calculated based insufficient number of samples.

## **Water Movement**

Solution collected from each sampler varied based on several factors. Moisture of surrounding soil and ability of the lysimeter to maintain a vacuum would account for variability in solution collection. The length of time allowed for sample collection was constant to ensure the samples collected were uniform within a given instance. Vertical movement of the saturation zone was expected at higher emitter rates after observation of puddles resulting from surfacing during application events. According to Kafkafi (1994) puddles are indicative of discharge rates in excess of soil infiltration rates resulting in greater vertical movement. One solution sample was obtained from each lysimeter regardless of volume within the lysimeter, making determination of moisture at a given location in the soil profile undeterminable. The effect may be minimized in future studies by constructing lysimeters to the same length regardless of depth or measurement of total solution collected from each lysimeter. Installation of soil moisture probes at depths corresponding to lysimeter placement would provide more accurate estimate of water movement. Soil cores would offer the ability to determine soil moisture as well as analysis of soil for comparison of soil and solution concentrations. Soil cores are extremely destructive with regards to the site, and potentially, the irrigation tapes.

A pressure differential was observed in field via pressure gauges between the inlet and distal ends of 2.38 L h<sup>-1</sup> irrigation tapes. Solution collection at the distal end produced fewer solution samples at each sampling event. Emitters using a discharge rate of 0.72 L h<sup>-1</sup> did not demonstrate this trend therefore, data from the inlet ends of each rate will be discussed from this point forward. On average eight lysimeters produced adequate solution at both inlet and distal ends for each sampling event. Lack of sample

collected from every lysimeter may indicate longer sampling periods are required to allow for adequate collection of solution for analysis. Longer sampling periods may prove problematic as the solution remains in contact with the atmosphere within the lysimeter resulting in changes in solution pH from reaction with atmospheric CO<sub>2</sub> and nutrient concentration. Further investigation could determine the extent of this effect.

Lysimeters were rinsed prior to placement and allowed to equilibrate with the soil matrix for eight months prior to the first extraction. Solution sample recovery was attempted from each lysimeter allowing for the opportunity to assess the condition of lysimeter. Throughout the sampling time three samplers were found to have inadequate seals where the fitting attached to the PVC cap. This was remedied by cleaning the cap and fitting and applying a silicone sealant. Despite the use of protective covers placed across fittings at surface, one lysimeter was found to have been damaged resulting in loss of a lysimeter. A bent fitting was found after the final effluent application for the 2006 growing season, and thus does not impact the results of this study.

In future studies soil sample analysis would offer added information pertaining to the sorption capacity of this site. A more complete study is needed to determine the effects of crop production on nutrient removal including yield data. This would also provide an indicator for water use efficiency based on emitter rate. While surface characteristics may appear to indicate high flow rates were inadequate for this particular site, crop production may produce a contradictory outcome. Examining solutions obtained following effluent applications produces trends following the expected outcome for this type of experiment.

## Nitrogen

For emitter application rates of  $0.72 \text{ L h}^{-1}$  ammonium concentrations on 14 May 2006 show no difference in concentration prior to effluent application throughout the soil (Figure 5). Concentrations following the third effluent application on 26 July 2006 produced similar results (Figure 6). Statistical analysis indicates no significant correlation between  $\text{NH}_4^+$ -N concentrations and time. No relationship was found between lysimeters location and water soluble  $\text{NH}_4^+$ -N concentrations. Lack of significant correlation between lysimeter locations with respect to irrigation tape indicates no preferential movement throughout the profile, thus  $\text{NH}_4^+$ -N is uniformly distributed at the  $0.72 \text{ L h}^{-1}$  emitter application rate. Uniform dispersion results in  $\text{NH}_4^+$ -N readily available throughout the profile.

At emitter application rates of  $2.38 \text{ L h}^{-1}$   $\text{NH}_4^+$ -N was present on 14 May 2006 prior to the first effluent application (Figure 7). Again, no significant correlation was found between  $\text{NH}_4^+$ -N concentration and time of extraction. Increased concentrations are evident in Figure 7 above and below the irrigation tape. The presence of  $\text{NH}_4^+$ -N in solution prior to effluent application may result from residual organic material that may remain in the profile or naturally occurring background levels. Uniform dispersion following the third effluent application is evident regardless of depth or lateral movement of moisture resulting in  $\text{NH}_4^+$ -N available throughout the soil profile (Figure 8). Uniform dispersion differed from the findings of Haynes (1990) which found that  $\text{NH}_4^+$ -N concentrations increased below the irrigation tape.

At emitter application rates of  $0.72 \text{ L h}^{-1}$  concentrations of  $\text{NO}_3^-$ -N increased at a depth of 60 cm; however it was uniformly distributed above this point on 14 May 2006

prior to effluent application (Figure 9). A positive correlation ( $r=0.50$ ,  $p<0.0004$ ) was found with time of sample acquisition indicating increased concentrations with each subsequent effluent application. Following the third effluent application  $\text{NO}_3^-$ -N concentrations increased relative to background levels (Table 2). Although  $\text{NO}_3^-$ -N increased, there was a uniform distribution of  $\text{NO}_3^-$ -N throughout the soil (Figure 10) as indicated by the lack of significant correlation between lysimeter location and  $\text{NO}_3^-$ -N concentration.

Emitter application rates of  $2.38 \text{ L h}^{-1}$  indicate prior to effluent application on 14 May 2006  $\text{NO}_3^-$ -N concentrations were uniform throughout the soil profile (Figure 11) and  $\text{NO}_3^-$ -N concentrations did not increase over time (Figure 12). Nitrate-N concentrations decreased with depth ( $r=-0.35$ ,  $p=0.0215$ ) indicating that downward movement was not occurring. This would signify  $\text{NO}_3^-$ -N concentrations are increasing above the irrigation tape, in the rooting zone of the plants. Laher and Avnimelech (1980) found that under saturated conditions, nitrification may be inhibited resulting in lower concentrations of  $\text{NO}_3^-$ -N with respect to subsurface drip irrigation. However, no increase of  $\text{NH}_4^+$ -N below the irrigation tape is evident indicating nitrification is not being inhibited. Cote et al. (2003) found mobile nutrient ( $\text{NO}_3^-$ -N) concentrations were highest further away and above the emitter when applied at the beginning of the application event based on modeled data. Significant positive correlation ( $r=0.42$ ,  $p<0.0048$ ) was found between lateral movement with respect to irrigation tape. This correlation indicates increased concentrations were detected at increased lateral distance from the irrigation tape. Thus,  $\text{NO}_3^-$ -N is moving with the wetting front which resembled the findings of Li et al. (2004). Laher and Avnimelech (1980) produced similar results in

which  $\text{NO}_3^-$ -N increased as distance from application source increased.

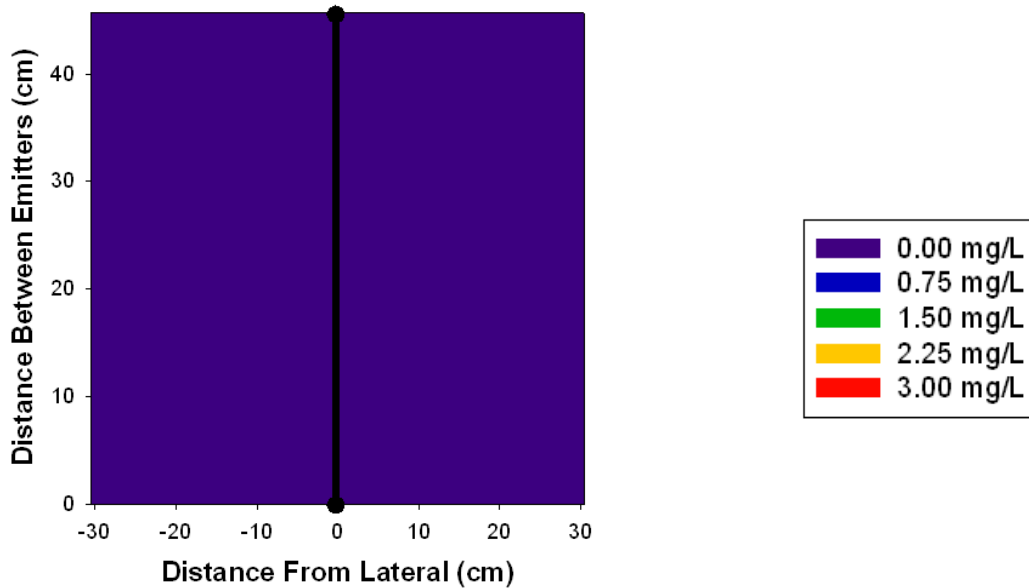

Figure 5. Ammonium-N concentration ( $\text{mg L}^{-1}$ ) on 14 May 2006 from  $0.72 \text{ L h}^{-1}$  emitter application rate at the depth of 30 cm. Background concentration prior to first effluent application event. Black line located at zero distance from the irrigation tape indicates location of irrigation tape with respect to the x-axis.

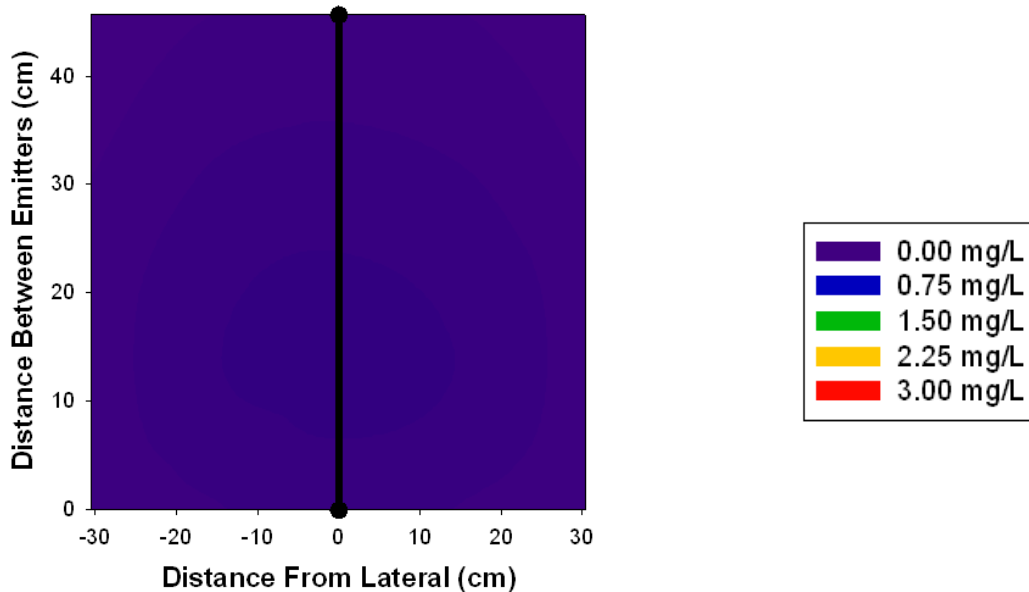

Figure 6. Ammonium-N concentration ( $\text{mg L}^{-1}$ ) on 26 July 2006 from  $0.72 \text{ L h}^{-1}$  application rates at the depth of 30 cm. At 60 cm depth solution samples were obtained from limited lysimeters resulting in an incomplete graph. No solution obtained from lysimeters located at 15 cm depth. Black line located at zero distance from the irrigation tape indicates location of irrigation tape with respect to the x-axis.



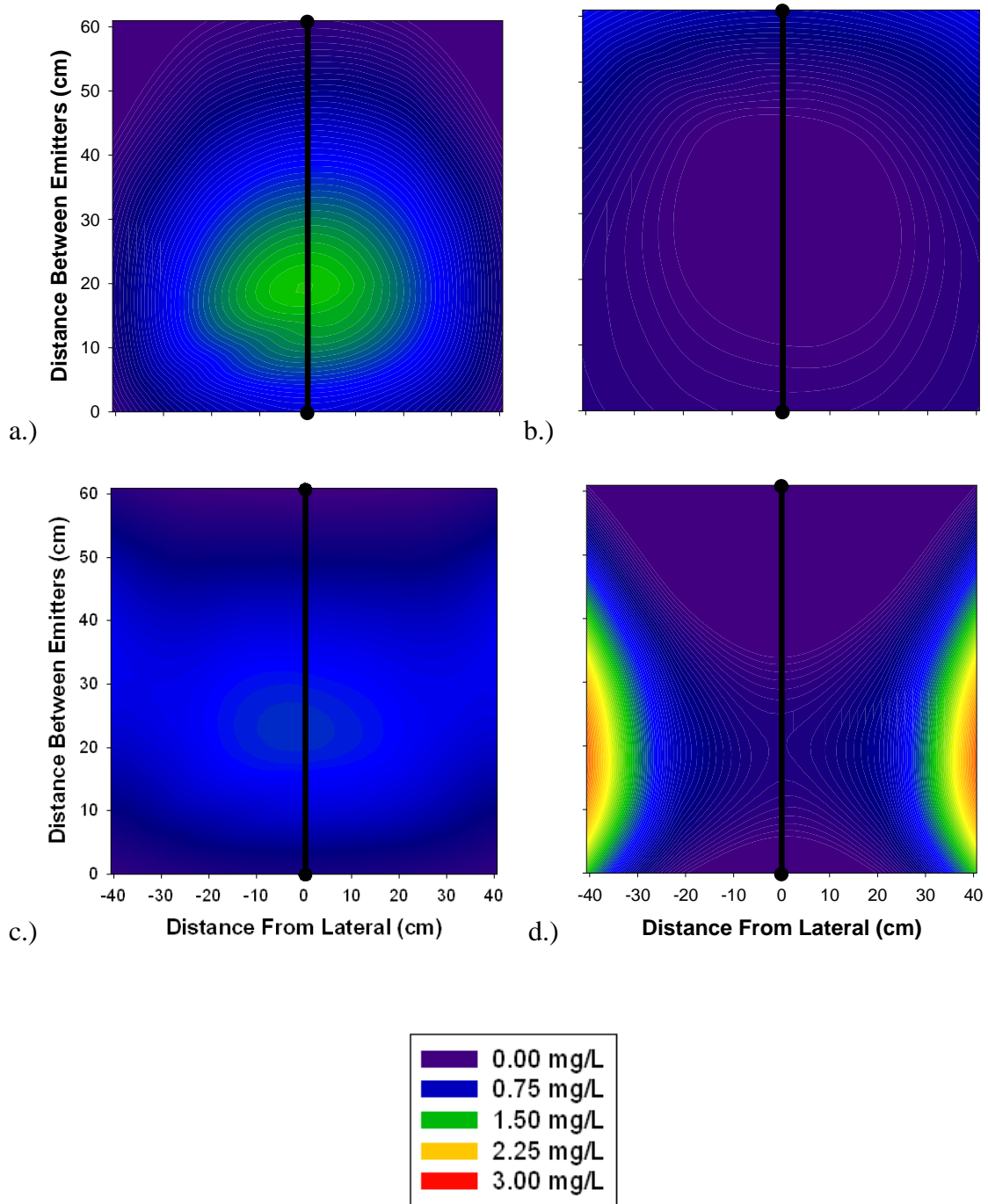

Figure 7. Ammonium-N concentration ( $\text{mg L}^{-1}$ ) on 14 May 2006 from  $2.38 \text{ L h}^{-1}$  emitter application rate at depths of a.) 15 cm, b.) 30 cm, c.) 45 cm, and d.) 60 cm. Black line located at zero distance from the irrigation tape indicates location of irrigation tape with respect to the x-axis.

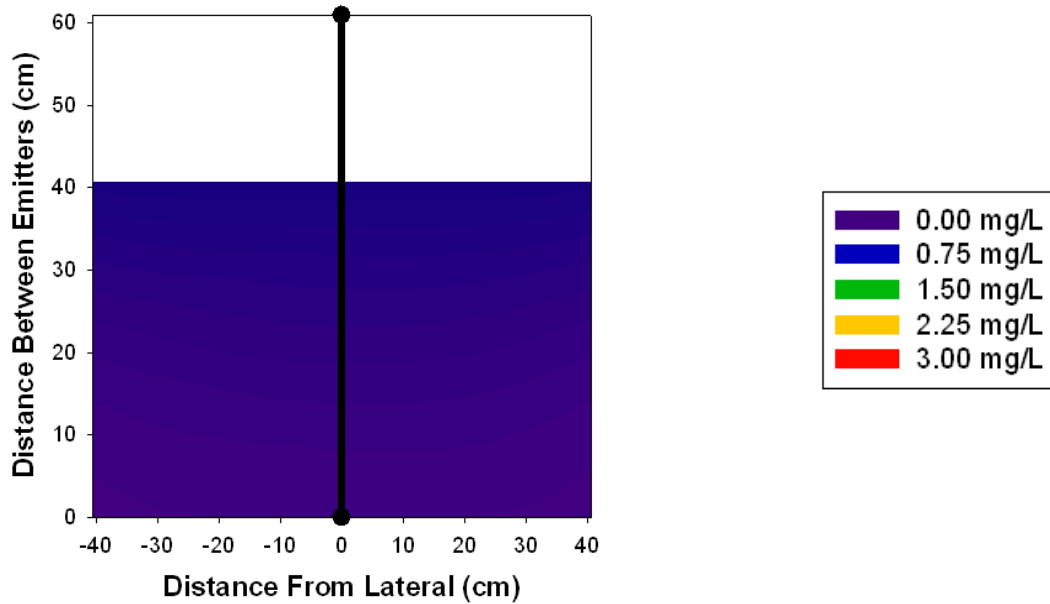

Figure 8. Ammonium-N concentration ( $\text{mg L}^{-1}$ ) on 26 July 2006 from  $2.38 \text{ L h}^{-1}$  emitter application rates at the depth of 60 cm. At 60 cm depth solution samples were obtained from limited lysimeters resulting in an incomplete graph. No solution obtained from lysimeters located at 15, 30, and 45 cm depth. Black line located at zero distance from the irrigation tape indicates location of irrigation tape with respect to the x-axis.

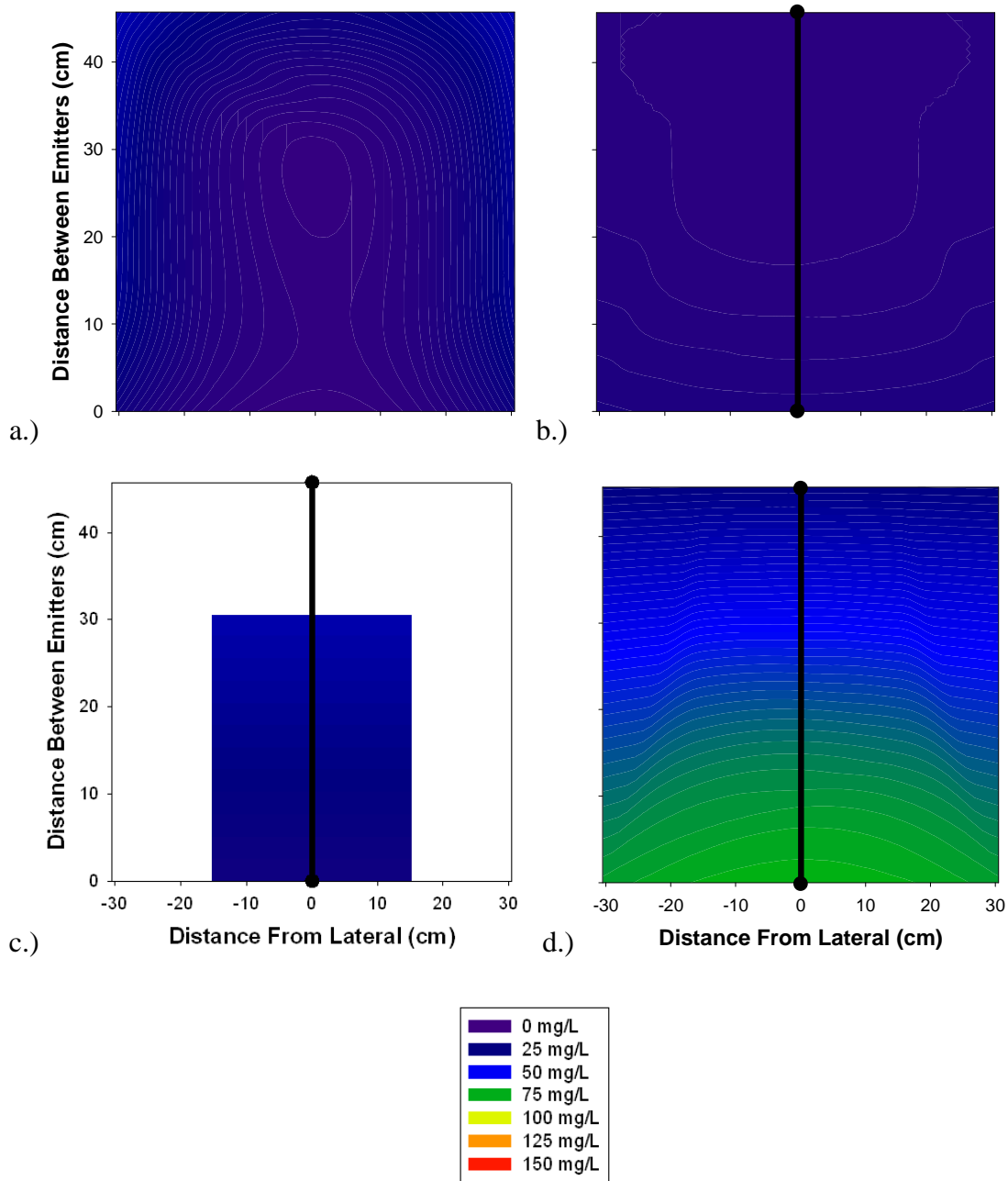

Figure 9. Nitrate-N concentration (mg L<sup>-1</sup>) on 14 May 2006 from 0.72 L h<sup>-1</sup> emitter application rate at depths of a.) 15 cm, b.) 30 cm, c.) 45 cm, and d.) 60 cm. At 45 cm depth solution samples were obtained from limited lysimeters resulting in an incomplete graph. Black line located at zero distance from the irrigation tape indicates location of irrigation tape with respect to the x-axis.

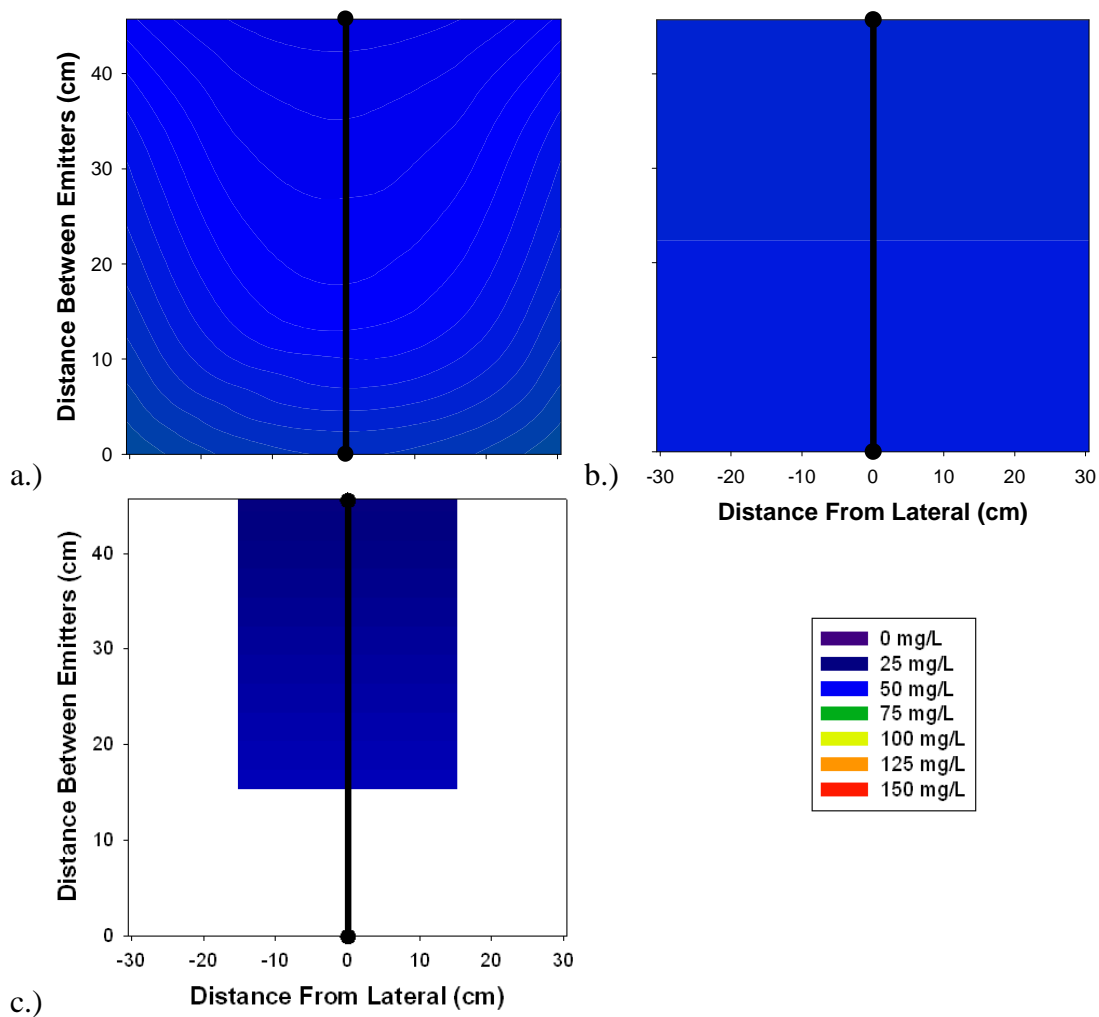

Figure 10. Nitrate-N concentration ( $\text{mg L}^{-1}$ ) on 26 July 2006 from  $0.72 \text{ L h}^{-1}$  emitter application rate at depths of a.) 30 cm, b.) 45 cm, and c.) 60 cm. At 60 cm depth solution samples were obtained from limited lysimeters resulting in an incomplete graph. No solution obtained from lysimeters located at 15 cm depth. Black line located at zero distance from the irrigation tape indicates location of irrigation tape with respect to the x-axis.

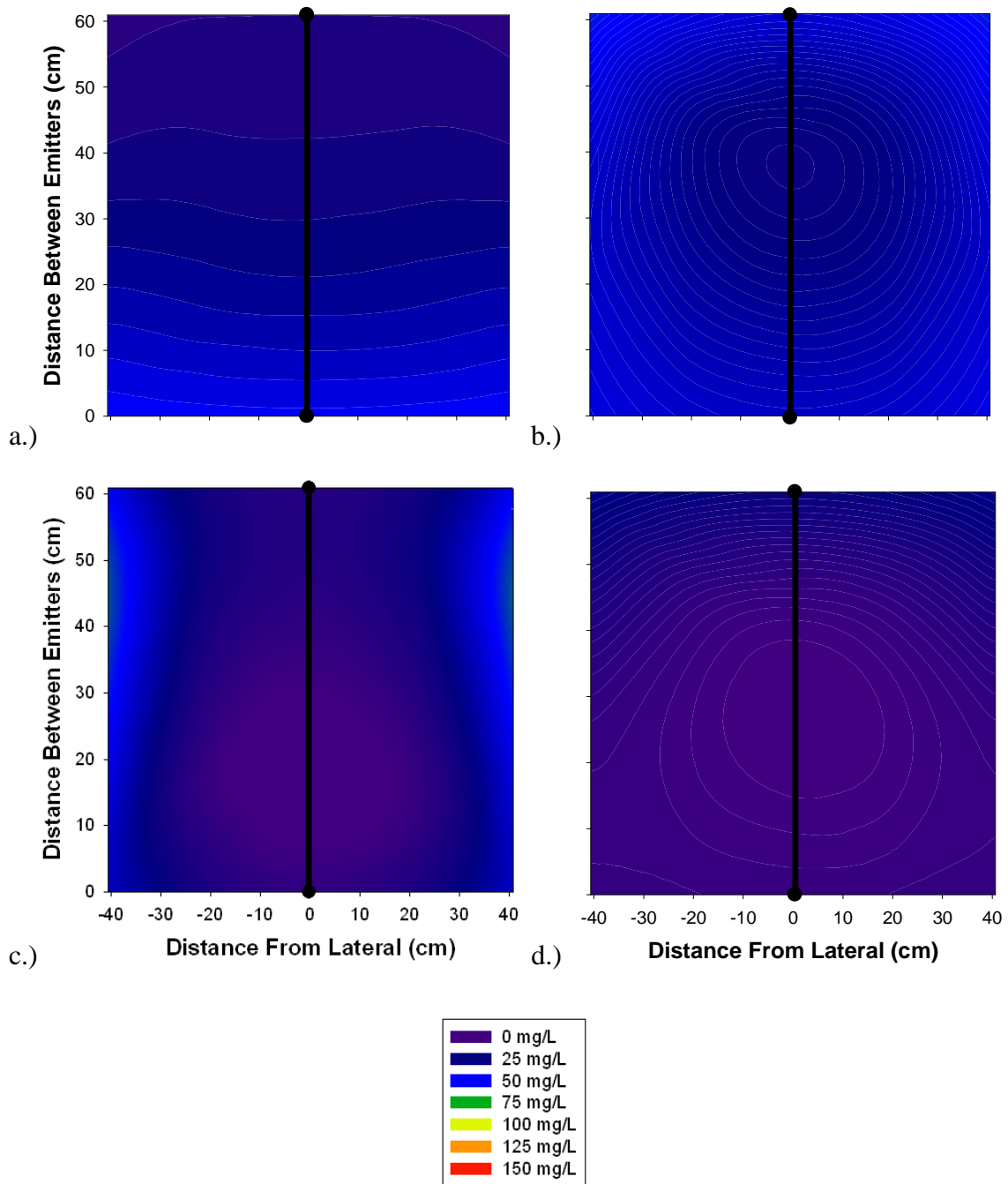

Figure 11. Nitrate-N concentration (mg L<sup>-1</sup>) on 14 May 2006 from 2.38 L h<sup>-1</sup> emitter application rates at depths of a.) 15 cm, b.) 30 cm, c.) 45 cm, and d.) 60 cm. Black line located at zero distance from the irrigation tape indicates location of irrigation tape with respect to the x-axis.

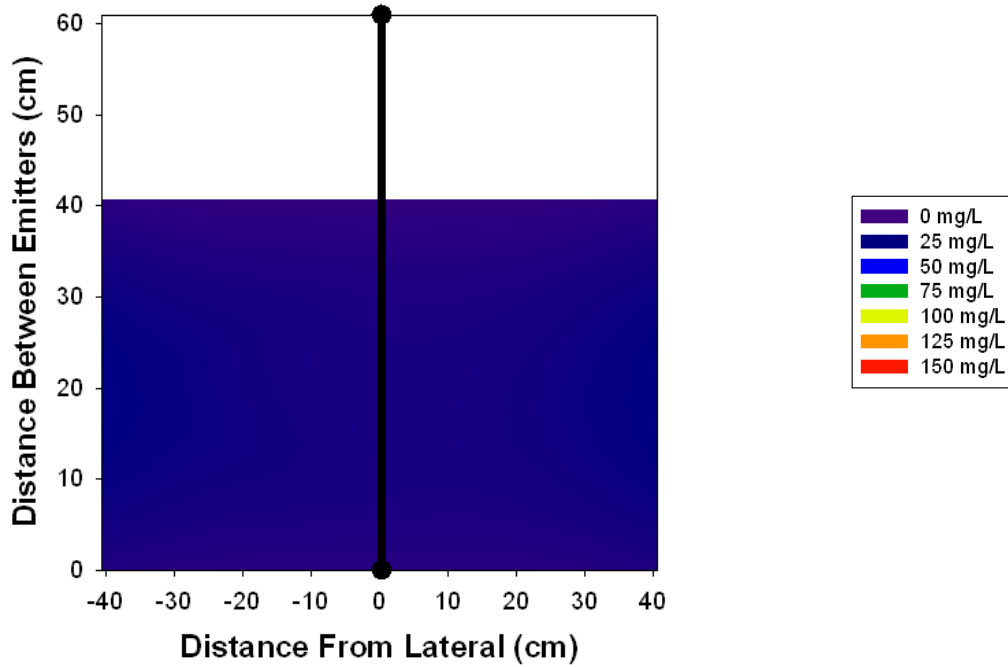

Figure 12. Nitrate-N concentration ( $\text{mg L}^{-1}$ ) on 26 July 2006 from  $2.38 \text{ L h}^{-1}$  emitter application rates at the depth of 60 cm. At 60 cm depth solution samples were obtained from limited lysimeters resulting in an incomplete graph. No solution was obtained from lysimeters located at 15, 30, and 45 cm depth. Black line located at zero distance from the irrigation tape indicates location of irrigation tape with respect to the x-axis.

## Orthophosphates

Orthophosphate concentrations from the  $0.72 \text{ L h}^{-1}$  emitter application rate indicate low concentrations present on 14 May 2006 prior to effluent application (Figure 13). After three effluent applications, concentrations did not change (Figure 14). As indicated by the lack of correlation between time of sampling and concentration. However, a significant negative correlation ( $r=-0.54$ ,  $p=0.0002$ ) exists between depth and concentration. This indicates that concentration decrease with depth, thus introduction of orthophosphates into groundwater is not of concern. No correlation was determined for lateral movement through the profile signifying uniform dispersion through the soil at a given soil depth.

For the  $2.38 \text{ L h}^{-1}$  emitter application rate, the initial concentrations demonstrate orthophosphate was present prior to effluent application and increased ( $r=0.37$ ,  $p=0.0189$ ) following three effluent applications (Figure 16). Concentrations decreased with depth ( $r=-0.41$ ,  $p=0.0080$ ) indicating that OP was not transported via percolation toward the vadose zone (Figures 15 and 16). No correlation was found between lateral movement and concentration indicating uniform dispersion throughout the soil profile. Ben-Gal and Dudley (2003) found that with continuous irrigation, P concentrations remained high throughout the entire irrigation time. However, when irrigation occurred over shorter periods concentration increased but to a lower concentration than seen in the continuous application before leveling off.

Orthophosphate concentrations measured in extract solution (Appendices B, O, BB, and CC) were significantly lower than those measured from filtered effluent used for applications (Table 1). Sorption by the ceramic cups would account for initial decreases

as orthophosphate concentration of effluent used averaged at  $28.09 \text{ mg L}^{-1}$  while the average concentration extracted by the lysimeters ( $1.8 \text{ mg L}^{-1}$ ) was much lower. At the solution average pH of 7.2 for the site, phosphorus solubility is expected to decrease which would also account for the lower concentrations found. However, no statistical correlation was found to support a relationship between pH and orthophosphate concentration.



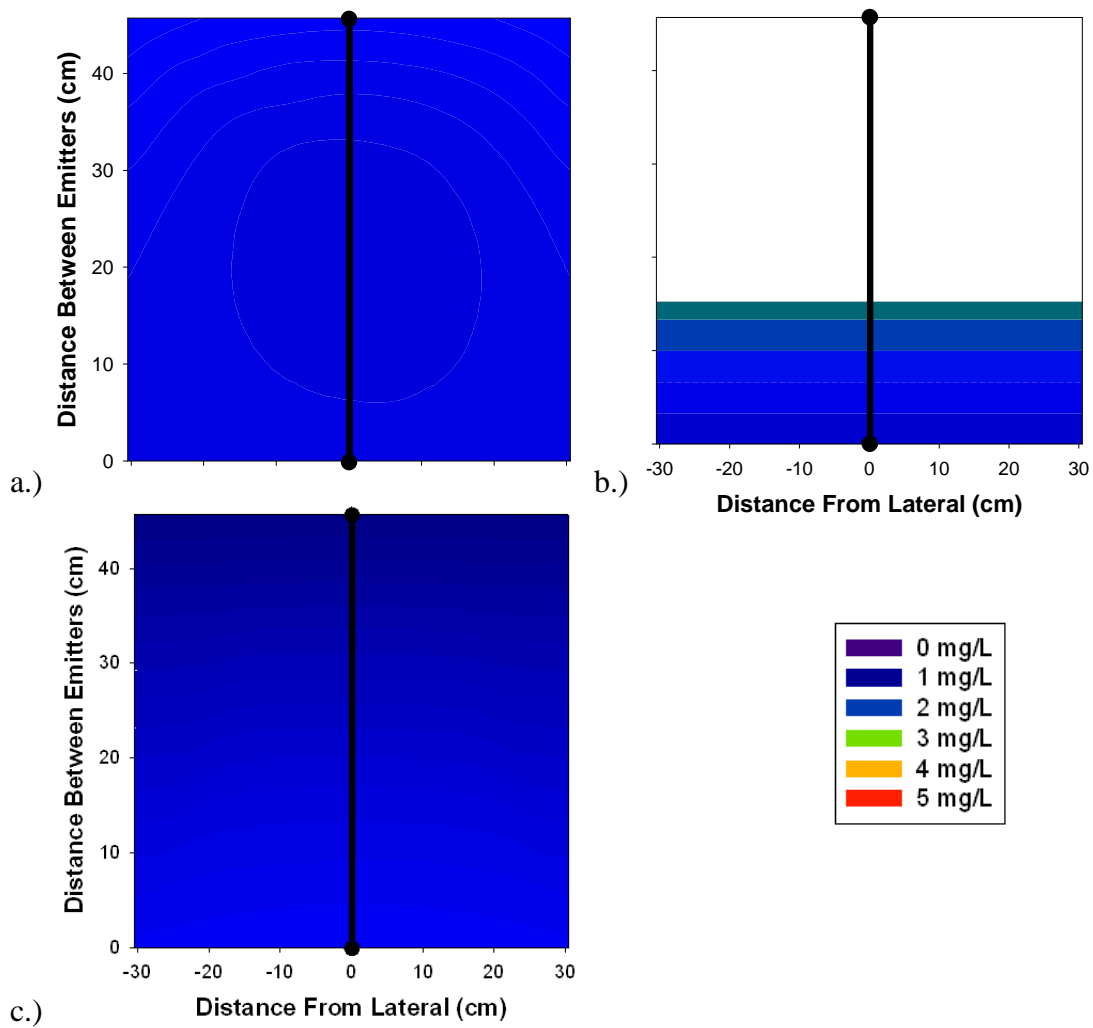

Figure 13. Orthophosphate concentration ( $\text{mg L}^{-1}$ ) on 14 May 2006 from  $0.72 \text{ L h}^{-1}$  emitter application rate at depths of a.) 15 cm, b.) 30 cm, and c.) 60 cm. No solution was obtained from lysimeters located at 45 cm depth. At 30 cm depth solution samples were obtained from limited lysimeters resulting in an incomplete graph. Black line located at zero distance from the irrigation tape indicates location of irrigation tape with respect to the x-axis.

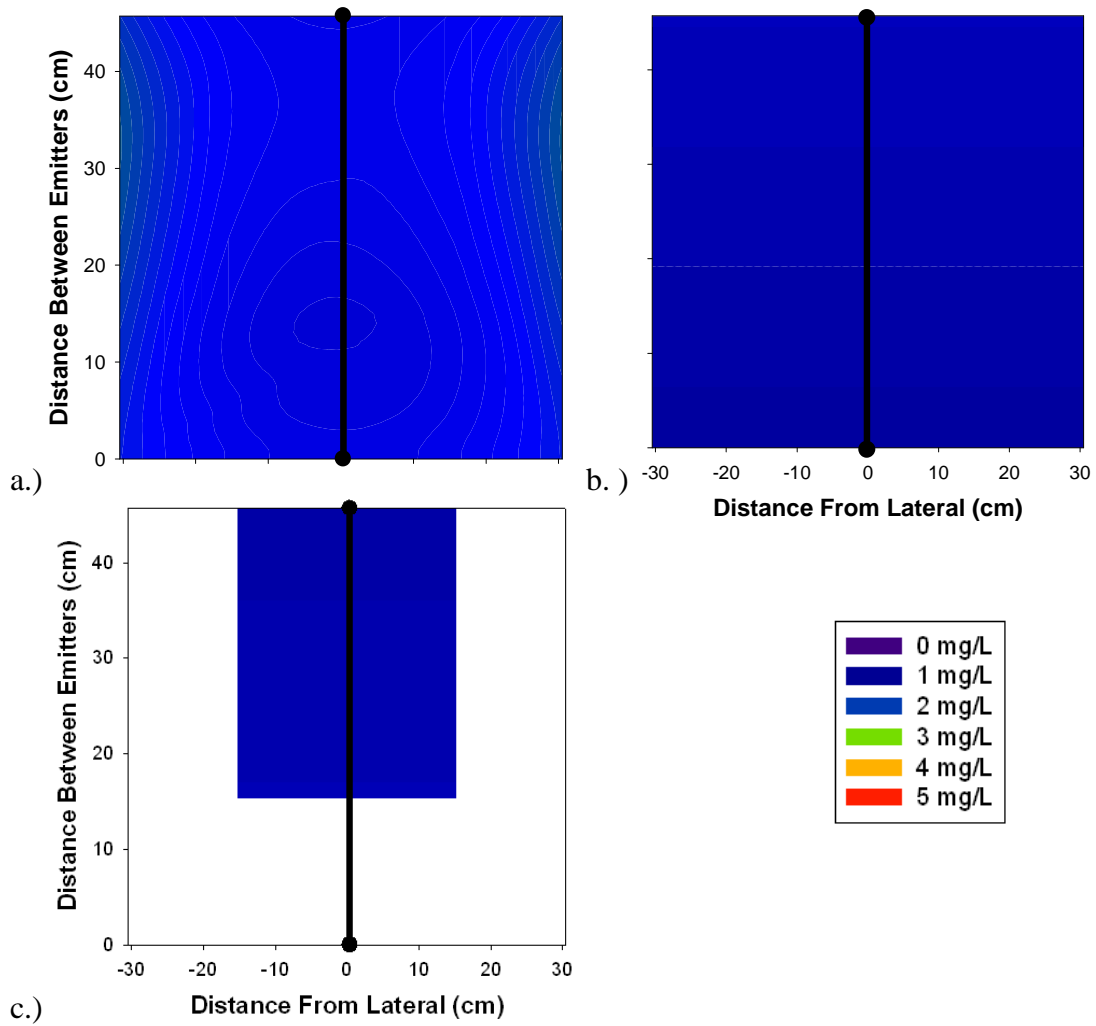

Figure 14. Orthophosphate concentration ( $\text{mg L}^{-1}$ ) on 26 July 2006 from  $0.72 \text{ L h}^{-1}$  emitter application rate at depths of a.) 30 cm, b.) 45 cm, and c.) 60 cm. No solution was obtained from lysimeters located at 15 cm depth. At 60 cm depth solution samples were obtained from limited lysimeters resulting in an incomplete graph. Black line located at zero distance from the irrigation tape indicates location of irrigation tape with respect to the x-axis.

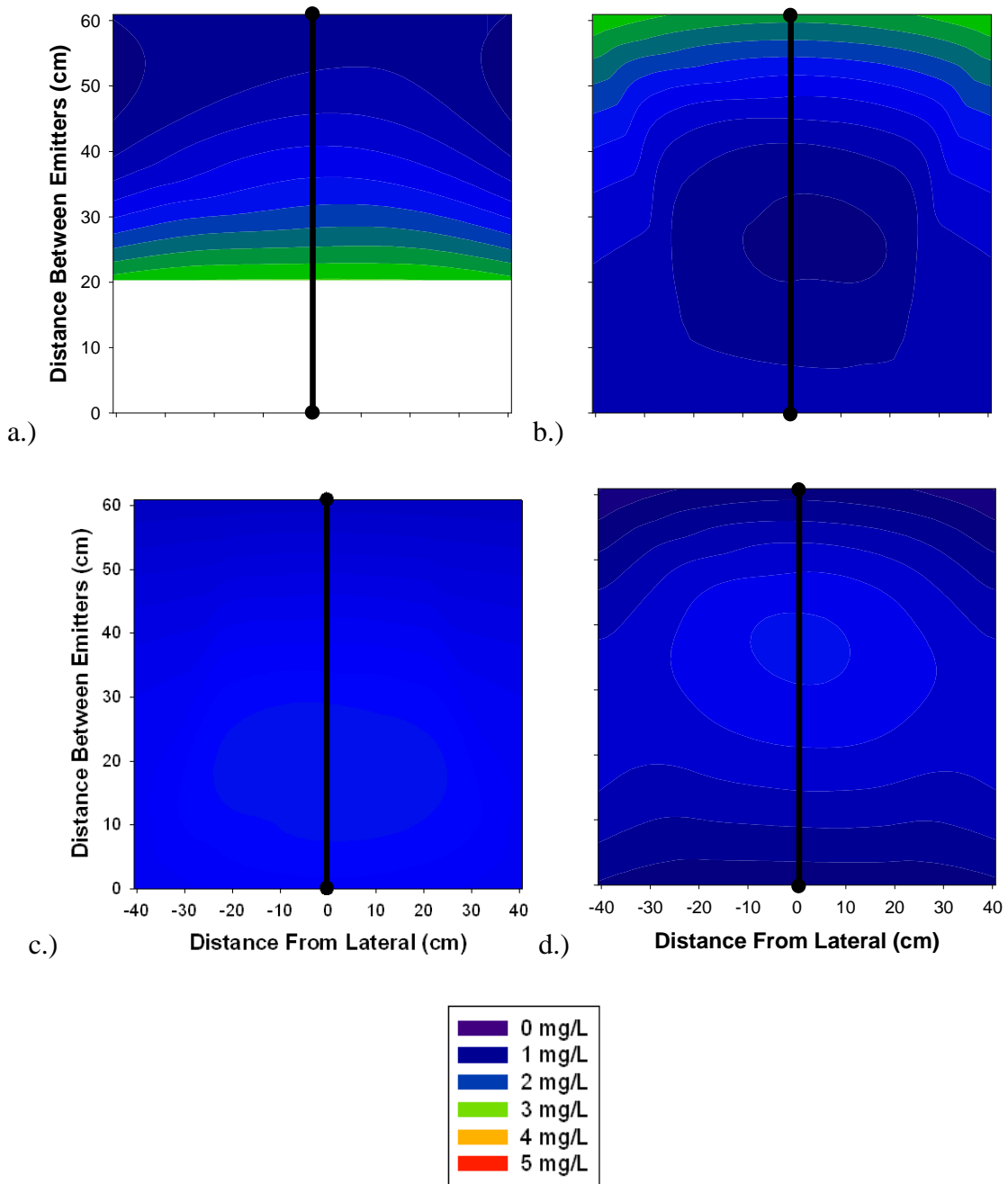

Figure 15. Orthophosphate concentration ( $\text{mg L}^{-1}$ ) on 14 May 2006 from  $2.38 \text{ L h}^{-1}$  emitter application rate at depths of a.) 15 cm, b.) 30 cm, c.) 45 cm, and d.) 60 cm. At 15 cm depth solution samples were obtained from limited lysimeters resulting in an incomplete graph. Black line located at zero distance from the irrigation tape indicates location of irrigation tape with respect to the x-axis.

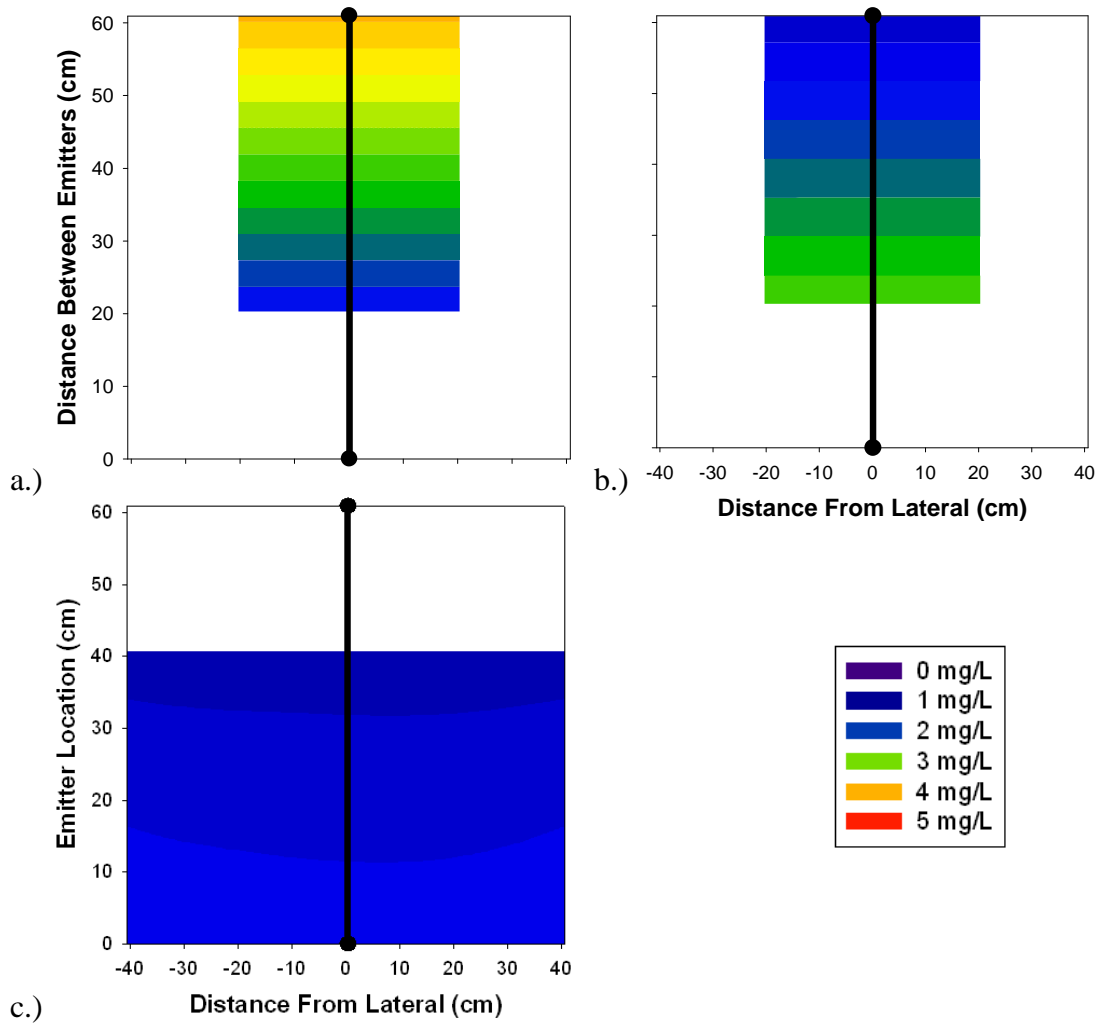

Figure 16. Orthophosphate concentration ( $\text{mg L}^{-1}$ ) on 26 July 2006 from  $2.38 \text{ L h}^{-1}$  emitter application rate at depths of a.) 15 cm, b.) 45 cm, c.) 60 cm. No solution was obtained from lysimeters located at 30 cm depth. At 15, 45, and 60 cm depth solution samples were obtained from limited lysimeters resulting in an incomplete graph. Black line located at zero distance from the irrigation tape indicates location of irrigation tape with respect to the x-axis.

## Calcium

On 14 May 2006 calcium was present in solution prior to effluent application at 0.72 L h<sup>-1</sup> emitter application rate (Figure 17). Concentrations increased following three effluent applications (Figure 18) with a significant positive correlation ( $r=0.40$ ,  $p<0.0078$ ) existing between concentration and sample. Despite trends seen in Figures 17 and 18 which would indicate concentrations decreased with depth. There was no significant correlation was found between lysimeter location and concentration. Despite overall increases in concentration, dispersion is uniform throughout the profile which follows the expected trend.

Low concentrations of calcium were present in the solution prior to effluent application at the 2.38 L h<sup>-1</sup> emitter application rate (Figure 19). Following three successive effluent applications concentrations increased significantly ( $r=0.50$ ,  $p<0.0013$ ) over time. A trend is evident between location of lysimeter and concentration (Figures 19 and 20); however no statistically significant relationship was found. This trend, similar to that found at the 0.72 L h<sup>-1</sup>, signifies dispersion of calcium throughout the profile is uniform.

Average calcium concentration from the effluent used for application was determined to be 72.6 mg L<sup>-1</sup> (Table 1) however, the concentrations removed through lysimeters were greater than 100 mg L<sup>-1</sup> with the average concentration at two times that found in the effluent (Appendix B, O, BB, and CC). Soils in the area are highly calcareous providing a likely source for increased calcium concentrations. With pH decreasing over time it is likely a cause for an increase in calcium solubility however, pH did not drop below 7.3 thus solubility would not be expected to increase by such a large

margin. The increased calcium and orthophosphate concentration are likely due to the neutral soil environment as well as the addition of N-Furic Acid injections into the irrigation water which began in 2006. Lindsay (2001) states that calcium phosphate species contribute significant amounts of calcium in neutral and calcareous soils which would account for the concentrations exceeding those found in the applied effluent. Calcium concentrations are also increasing over time with an average concentration of  $150 \text{ mg L}^{-1}$  prior to sampling and averaging  $210 \text{ mg L}^{-1}$  as of the final sampling on 9 August 2006. As concentrations are already high this increase is not as evident when compared to other parameters.

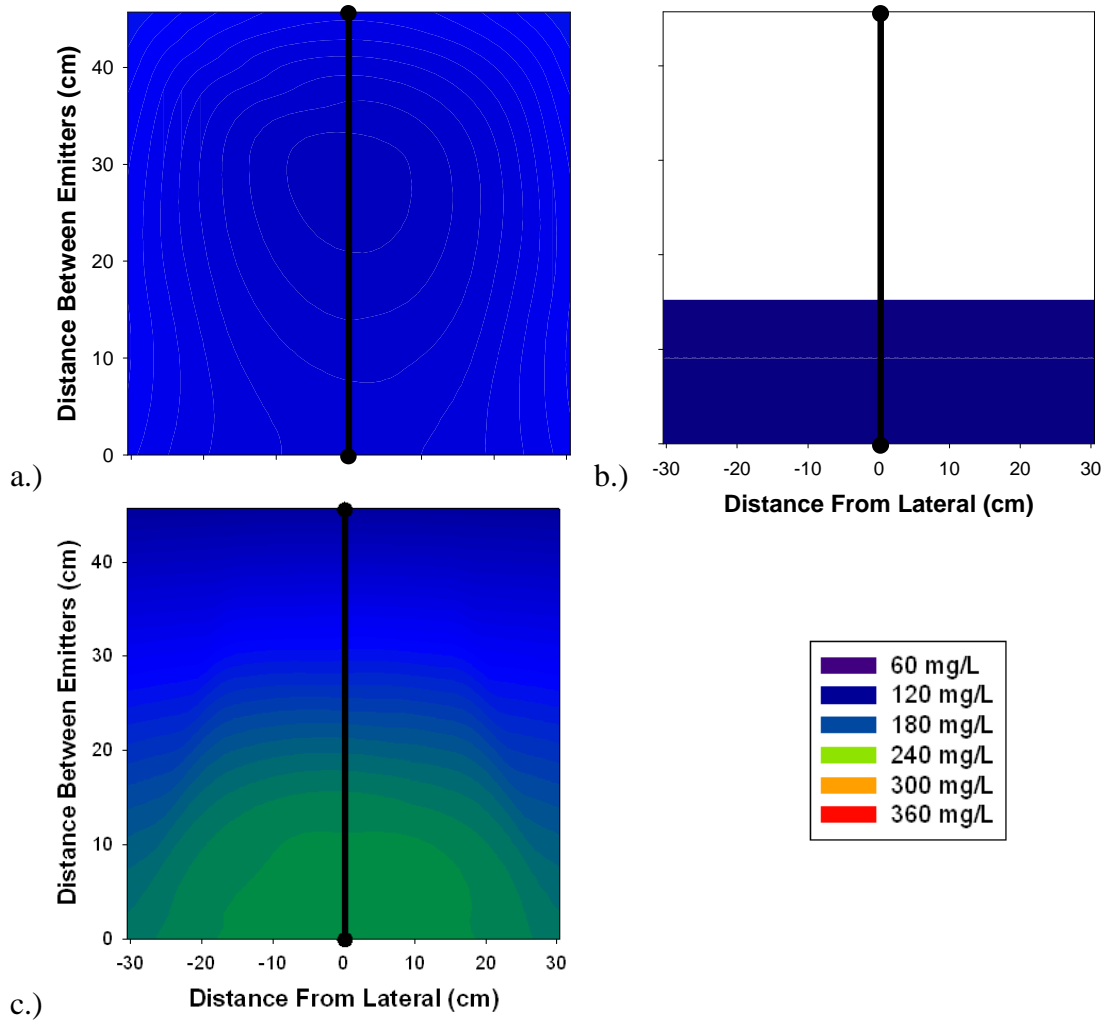

Figure 17. Calcium concentration ( $\text{mg L}^{-1}$ ) on 14 May 2006 from  $0.72 \text{ L h}^{-1}$  emitter application rate at depths of a.) 15 cm, b.) 30 cm, and c.) 60 cm. No solution was obtained from lysimeters located at 45 cm depth. At 30 cm depth solution samples were obtained from limited lysimeters resulting in an incomplete graph. Black line located at zero distance from the irrigation tape indicates location of irrigation tape with respect to the x-axis.

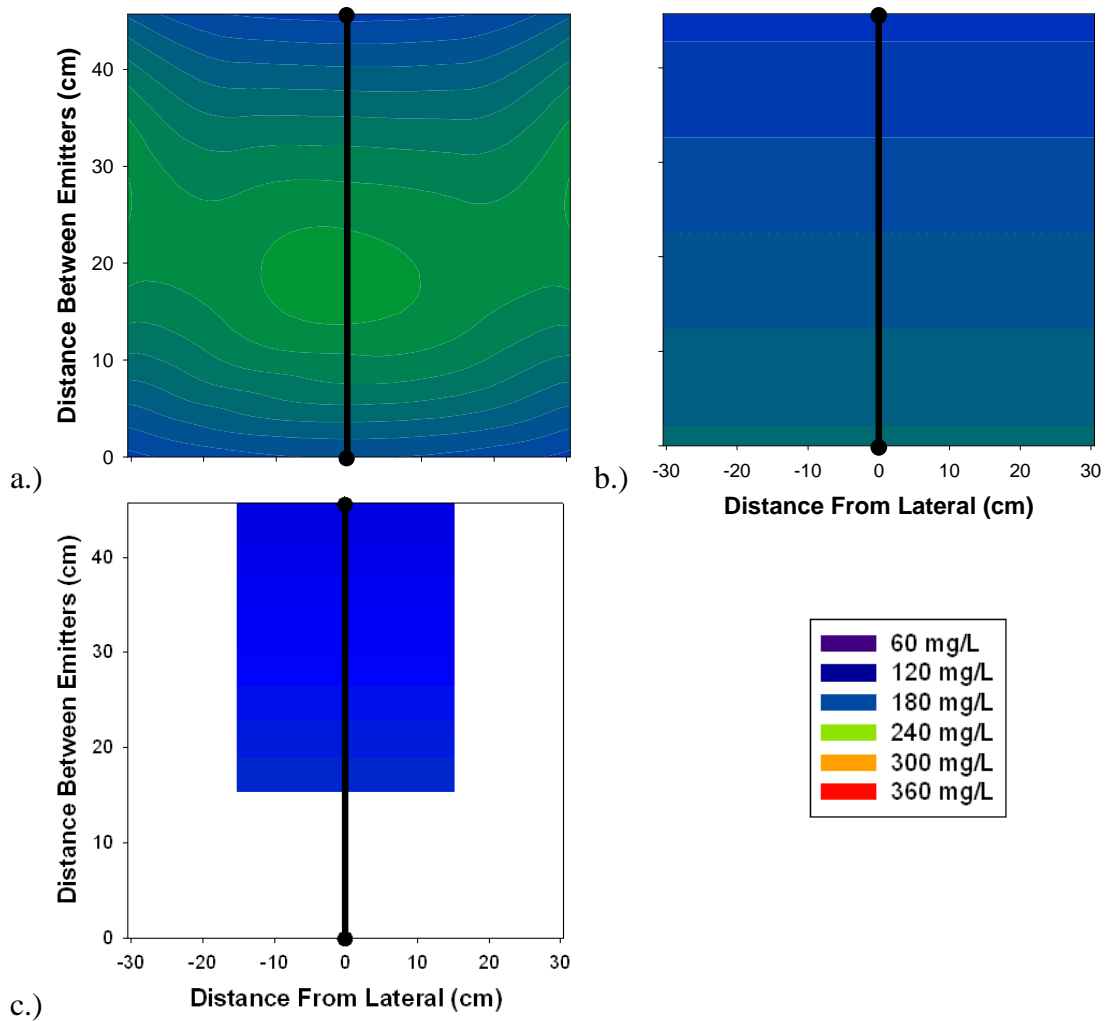

Figure 18. Calcium concentration ( $\text{mg L}^{-1}$ ) on 26 July 2006 from  $0.72 \text{ L h}^{-1}$  emitter application rate at depths of a.) 30 cm, b.) 45 cm, c.) 60 cm, and d.) 60 cm. No solution was obtained from lysimeters located at 15 cm depth. At 60 cm depth solution samples were obtained from limited lysimeters resulting in an incomplete graph. Black line located at zero distance from the irrigation tape indicates location of irrigation tape with respect to the x-axis.



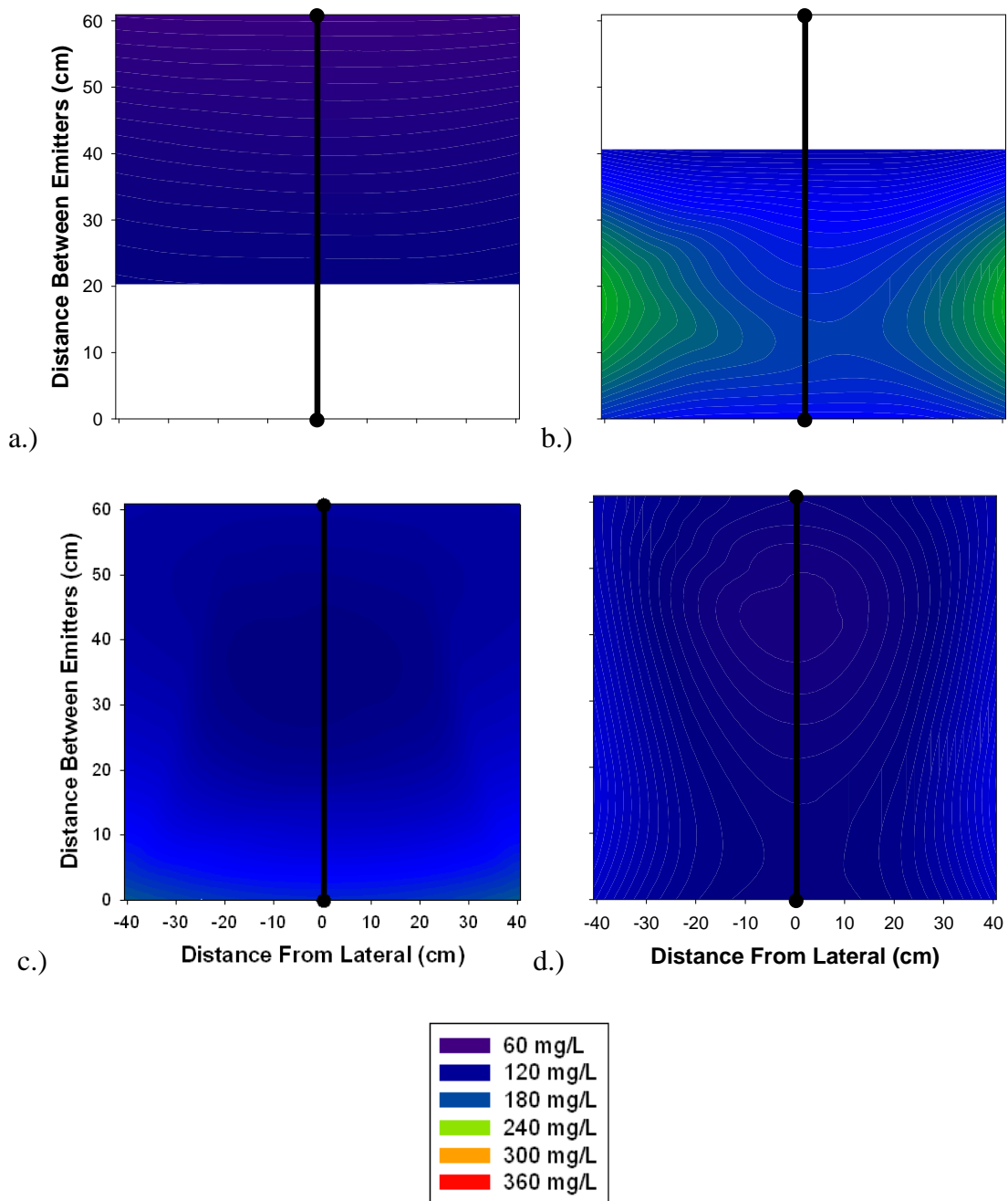

Figure 19. Calcium concentration ( $\text{mg L}^{-1}$ ) on 14 May 2006 from  $2.38 \text{ L h}^{-1}$  emitter application rate at depths of a.) 15 cm, b.) 30 cm, c.) 45 cm, and d.) 60 cm. At 15 and 30 cm depth solution samples were obtained from limited lysimeters resulting in an incomplete graph. Black line located at zero distance from the irrigation tape indicates location of irrigation tape with respect to the x-axis.

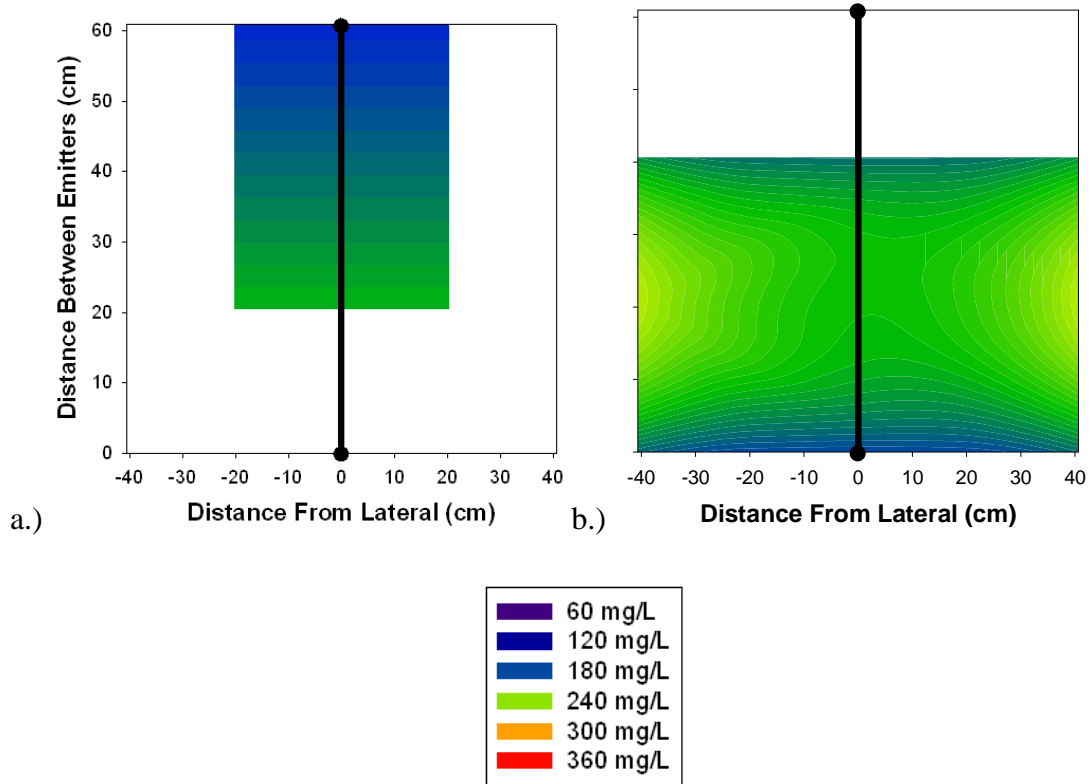

Figure 20. Calcium concentration ( $\text{mg L}^{-1}$ ) on 26 July 2006 from  $2.38 \text{ L h}^{-1}$  emitter application rate at depths of a.) 15 cm and b.) 60 cm. No solution was obtained from lysimeters located at 30 and 45 cm depth no figures were produced. At 15 and 60 cm depth solution samples were obtained from limited lysimeters resulting in an incomplete graph. Black line located at zero distance from the irrigation tape indicates location of irrigation tape with respect to the x-axis.

## Copper

On May 14 of 2006 copper was present in soil solution at emitter application rates of  $0.72 \text{ L h}^{-1}$ , prior to the application of effluent (Figures 21 and 22). Concentrations increased significantly ( $r=0.92$ ,  $p<0.0001$ ) following each effluent application event before reaching a maximum measured concentration of  $0.3 \text{ mg L}^{-1}$  by mid-July. Uniform dispersion is evident prior to application (Figure 22) with a trend developing by the third application event (Figure 23) indicating increased concentrations around the emitter. However these trends were not statistically significant.

For the  $2.38 \text{ L h}^{-1}$  emitter application rates copper concentrations on May 14 of 2006 (Figures 24 and 25) were low or below detection limits prior to effluent application. A significant increase ( $r=0.96$ ,  $p<0.0001$ ) was found following the third application event (Figure 26) indicating concentrations increased over time. A similar trend is evident in Figures 25 and 26 as seen at the  $0.72 \text{ L h}^{-1}$  emitter application rate with concentrations increased near the emitter. Again, this trend was not found to be statistically significant.

Despite increased concentrations following the final application event, low concentrations prior to effluent application indicate copper concentrations decrease to background levels following the discontinuation of fertigation each season. To determine the validity of this would require continued sampling throughout the year. Ali et al. (2002) found that copper concentrations of  $0.5 \text{ mg L}^{-1}$  were sufficient to reduce plant growth of maize. At a concentration of  $0.3 \text{ mg L}^{-1}$  potential for decreased yield exists if soil solution concentrations continue to increase despite discontinuation of effluent application.

L'Herroux et al. (1997) found that copper concentrations accumulated at the

surface and was primarily tied up in the organic matter fraction. Over the period of the study the copper concentration significantly increased, and was found in a more plant available form. However, based on lysimeter extractions, copper concentrations did not appear to follow any particular pattern in relationship to the irrigation tape placement or emitter rate. This determination is further supported by a lack of significant correlation existing between lysimeter location and irrigation tape. This lack of apparent concentration pattern indicates that any copper remaining soluble moves throughout the soil profile at a consistent rate rather than being associated with the wetting front or accumulating at the point of application (Figures 23 and 26). Studies (L'Herroux et al., 1997; Sukkariyah et al., 2007) found that increased copper concentration were associated with organic matter content of the soil when dealing with surface applications. Sukkariyah et al. (2007) found that while coarse textured soils resulted in increased movement of copper up to 0.75 m from the application point, this increase was not visible in the groundwater. It was stated that increased movement was affected by the soil texture as well as the low organic matter content at the point of application.

The fate of the copper requires further investigation to determine the likelihood of its introduction into local water systems. Copper concentrations are negatively correlated with solution pH for both emitter application rates ( $r=-0.64$  and  $-0.57$ ,  $p<0.0001$ ). Negative correlation indicates that as pH increases the concentration of copper in solution decreases following accepted solubility rules for copper. As pH decreases over time, copper concentrations are expected to increase. Copper concentrations in soil solution are also shown to be lower than that found in the effluent used (Table 1). It is possible that some sorption to the ceramic cup occurred; however, this effect would decrease after

subsequent extractions as the sorption sites associated with the ceramic cups would become saturated and would no longer be removing copper from solution.

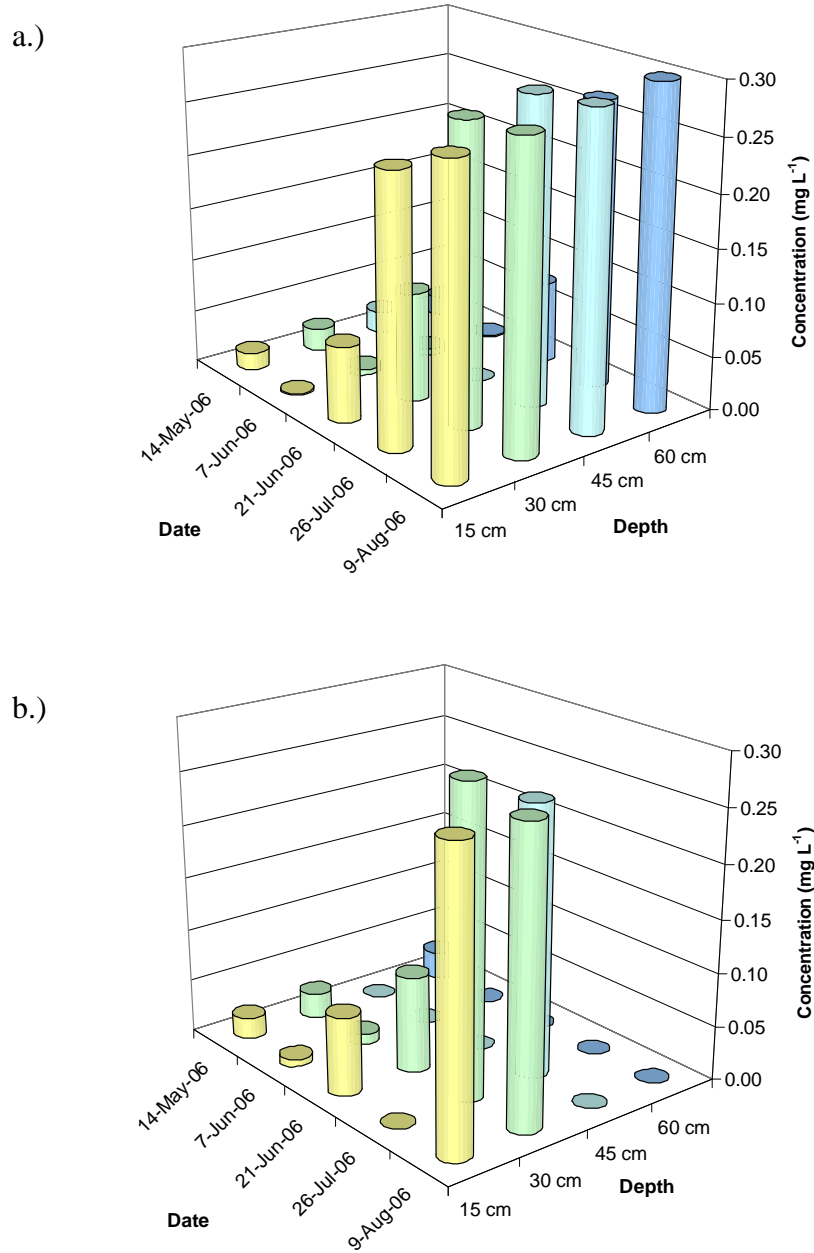

Figure 21. Copper concentrations (mg L<sup>-1</sup>) on dates of effluent application by depth at emitter application rate of 0.72 L h<sup>-1</sup> for lysimeters a.) 15 cm and b.) 30 cm from the irrigation tape.

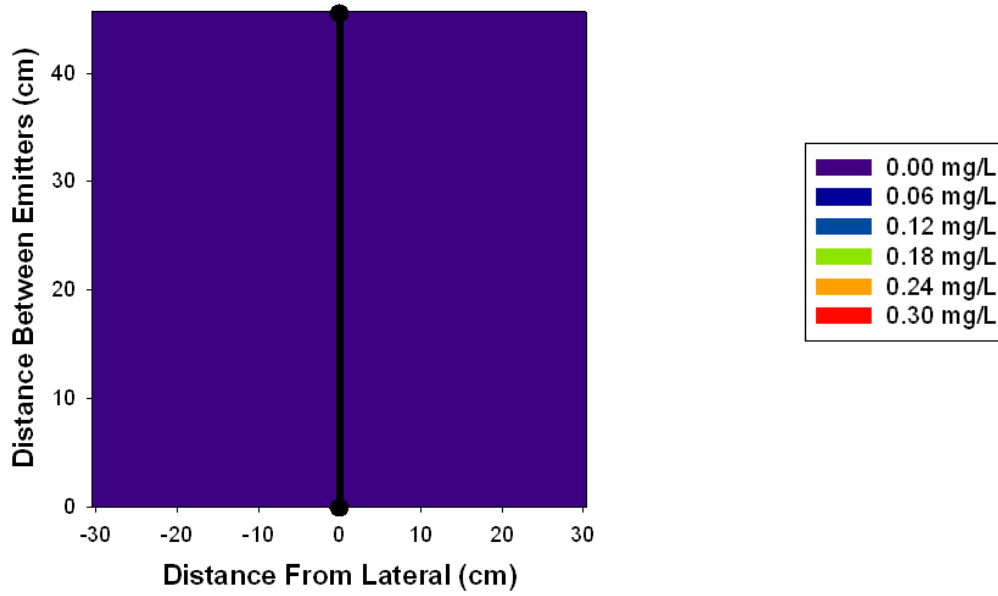

Figure 22. Copper concentration ( $\text{mg L}^{-1}$ ) on 14 May 2006 from  $0.72 \text{ L h}^{-1}$  emitter application rate at the depth of 60 cm. No solution was obtained from lysimeters located at 45 cm depth. At 30 cm depth solution samples were obtained from limited lysimeters resulting in an incomplete graph. Black line located at zero distance from the irrigation tape indicates location of irrigation tape with respect to the x-axis.

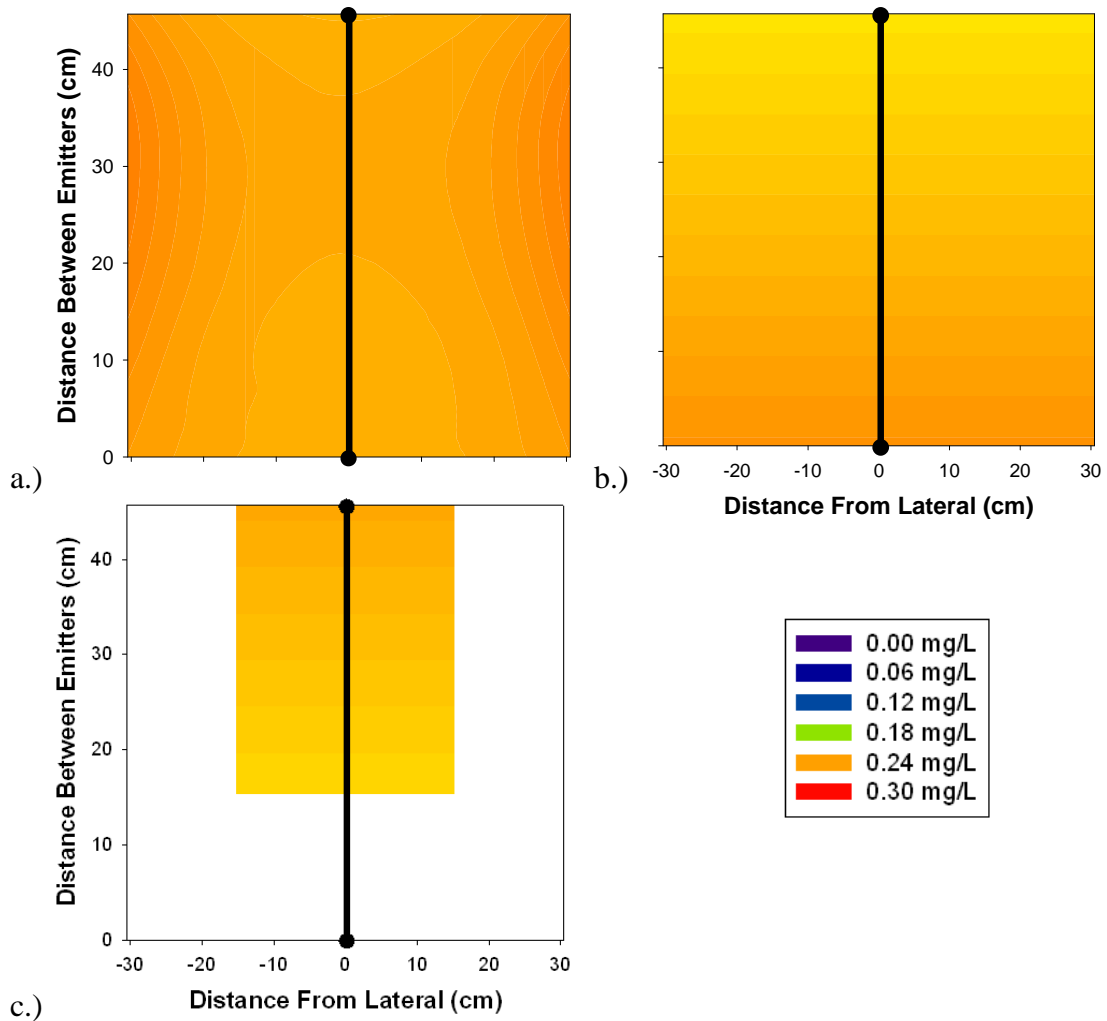

Figure 23. Copper concentration ( $\text{mg L}^{-1}$ ) on 26 July 2006 from  $0.72 \text{ L h}^{-1}$  emitter application rate at depths of a.) 30 cm, b.) 45 cm, and c.) 60 cm. No solution was obtained from lysimeters located at 15 cm depth. At 60 cm depth solution samples were obtained from limited lysimeters resulting in an incomplete graph. Black line located at zero distance from the irrigation tape indicates location of irrigation tape with respect to the x-axis.

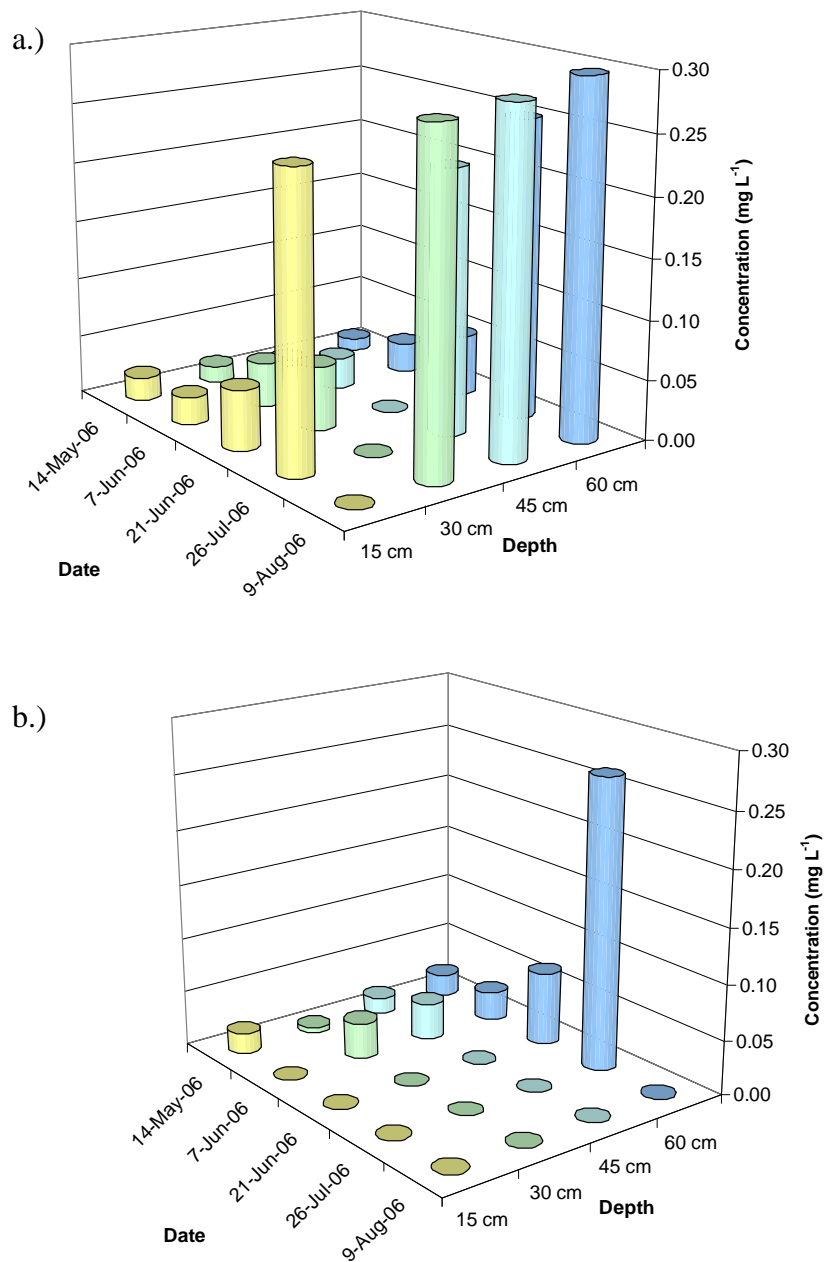

Figure 24. Copper concentrations ( $\text{mg L}^{-1}$ ) on dates of effluent application by depth at emitter application rate of  $2.38 \text{ L h}^{-1}$  for lysimeters a.) 20 cm and b.) 40 cm from the irrigation tape.



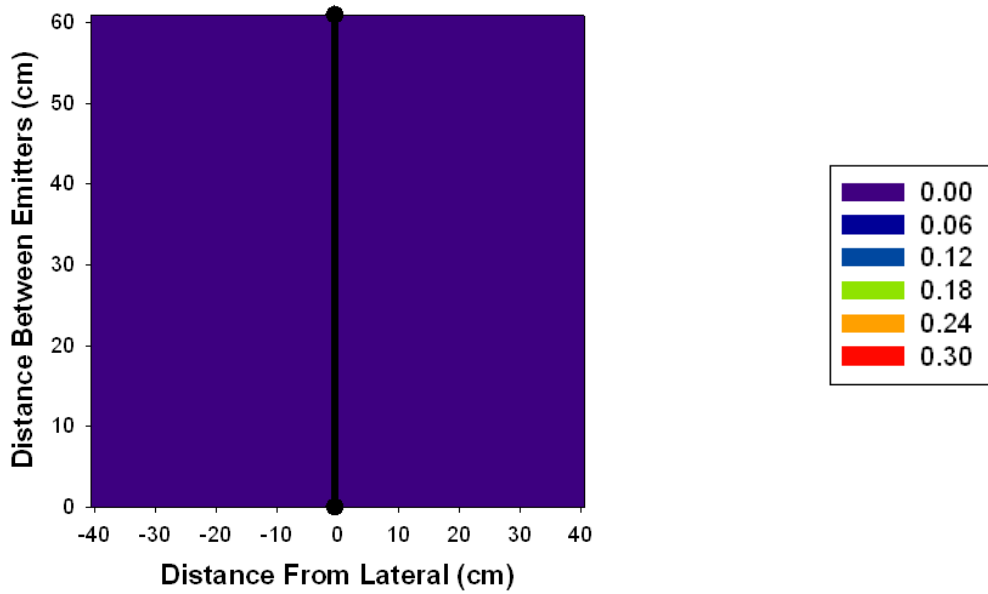

Figure 25. Copper concentration ( $\text{mg L}^{-1}$ ) on 14 May 2006 from  $2.38 \text{ L h}^{-1}$  emitter application rate at the depth of 60 cm. Black line located at zero distance from the irrigation tape indicates location of irrigation tape with respect to the x-axis.

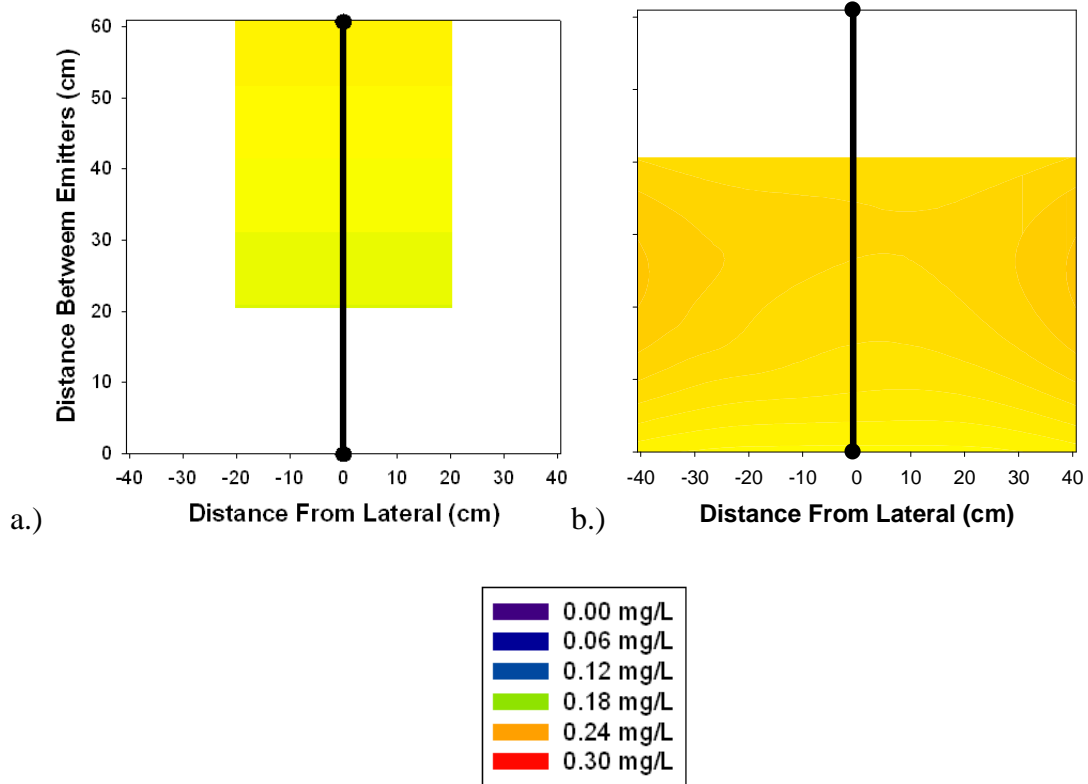

Figure 26. Copper concentration ( $\text{mg L}^{-1}$ ) on 26 July 2006 from  $2.38 \text{ L h}^{-1}$  emitter application rate at depths of a.) 15 cm and b.) 60 cm. No solution was obtained from lysimeters located at 30 and 45 cm depth no figures were produced. At 15 and 60 cm depth solution samples were obtained from limited lysimeters resulting in an incomplete graph. Black line located at zero distance from the irrigation tape indicates location of irrigation tape with respect to the x-axis.

## Zinc

At  $0.72 \text{ L h}^{-1}$  zinc is present in solution on 14 May 2006 prior to initial effluent applications for the 2006 season (Figure 27). Concentrations following the third application event (Figure 28) show concentrations decreased despite addition of effluent, however this decrease was not significant. Prior to application (Figure 27) zinc concentrations increased with depth with distance from the irrigation tape. Following the third application event (Figure 28) dispersion of zinc appears uniform throughout the profile. Lysimeter location was not found to be significantly correlated with concentration indicating zinc is not associated with emitter application points or wetting front.

Zinc concentrations at the  $2.38 \text{ L h}^{-1}$  emitter application rate were low to below detection limit on 14 May 2006 (Figure 30) prior to effluent application. Following the third effluent application event (Figure 31) concentrations appear to increase, however this trend was not found to be significant. Trends in distribution (Figure 30) indicate concentration increased with depth and lateral distance from irrigation tape prior to effluent application. Following three effluent applications (Figure 31) trends indicate concentrations increased near the surface. Similar to emitter application rates of  $0.72 \text{ L h}^{-1}$  no significant correlation exists between lysimeter location and concentration.

Zinc concentrations were significantly lower than that of the effluent used for applications (Table 1). Again some sorption to the ceramic cup may result in decreased concentrations. However, sorption alone would not account for such a decrease. Zinc in soil solution is a factor of pH and the amount absorbed on clay and organic surfaces (Havlin et al., 1999). Concentration are consistently low and do not seem to follow any

pattern of movement, which is supported by presence of no statically significant interactions between zinc concentrations and lysimeter location. L'Herroux et al. (1997) found that zinc concentrations accumulated in soils where pig slurry was applied to the surface, and was dominantly associated with the hydroxide fraction. Concentrations in leachate were found to be low indicating movement of zinc out of the soil profile was not occurring.

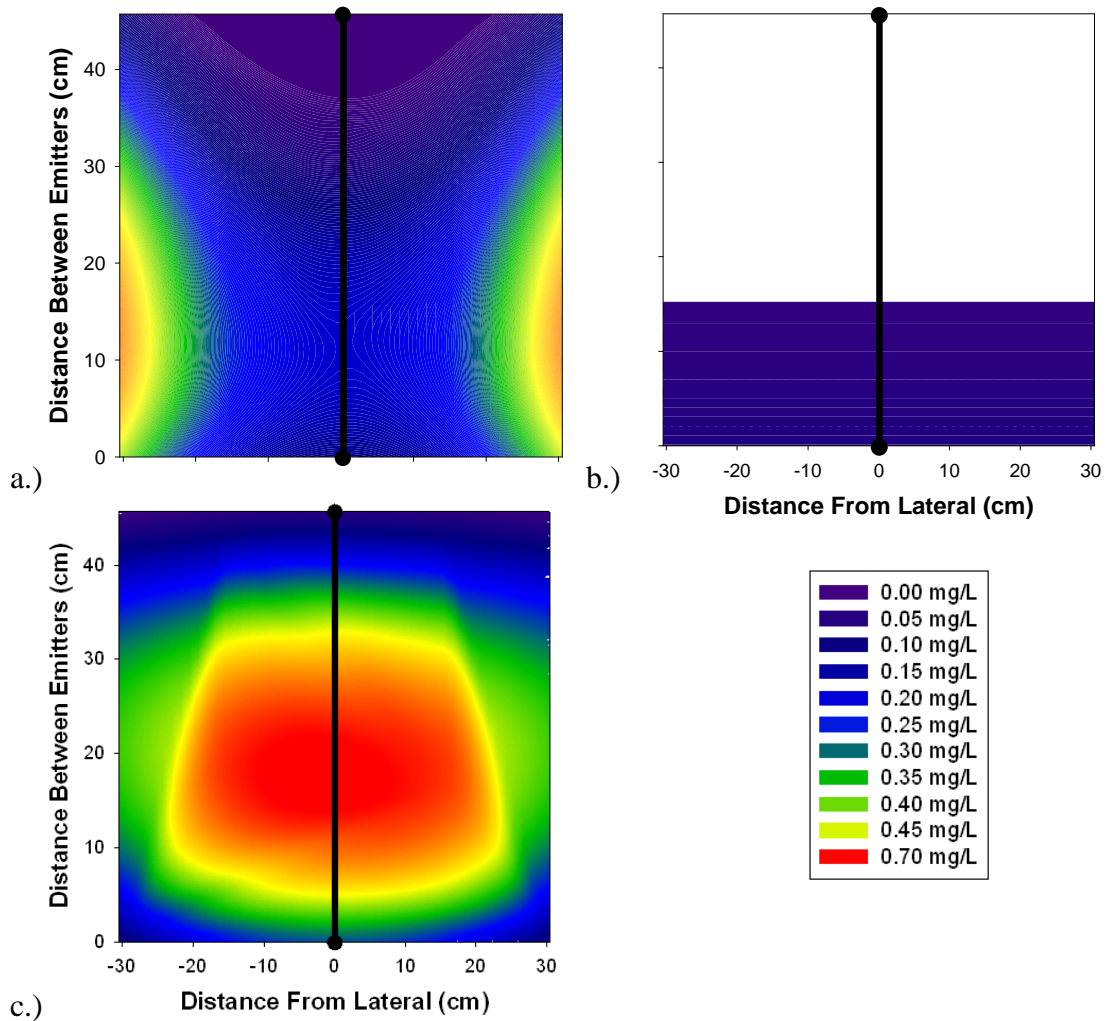

Figure 27. Zinc concentration ( $\text{mg L}^{-1}$ ) on 14 May 2006 from  $0.72 \text{ L h}^{-1}$  emitter application rate at depths of a.) 15 cm, b.) 30 cm and c.) 60 cm. No solution was obtained from lysimeters located at 45 cm depth. At 30 cm depth solution samples were obtained from limited lysimeters resulting in an incomplete graph. Black line located at zero distance from the irrigation tape indicates location of irrigation tape with respect to the x-axis.

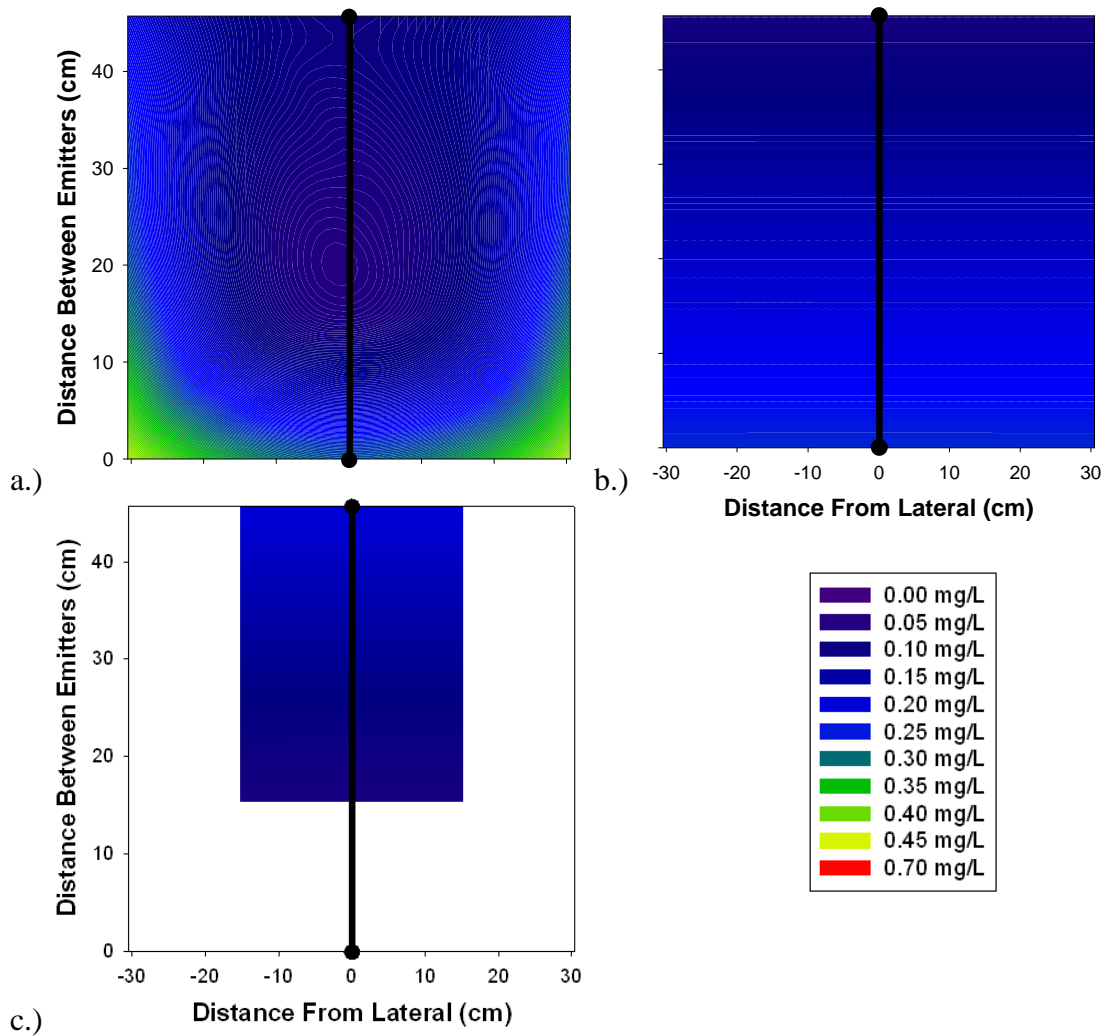

Figure 28. Zinc concentration ( $\text{mg L}^{-1}$ ) on 26 July 2006 from  $0.72 \text{ L h}^{-1}$  emitter application rate at depths of a.) 30 cm, b.) 45 cm, and c.) 60 cm. No solution was obtained from lysimeters located at 15 cm depth. At 60 cm depth solution samples were obtained from limited lysimeters resulting in an incomplete graph. Black line located at zero distance from the irrigation tape indicates location of irrigation tape with respect to the x-axis.

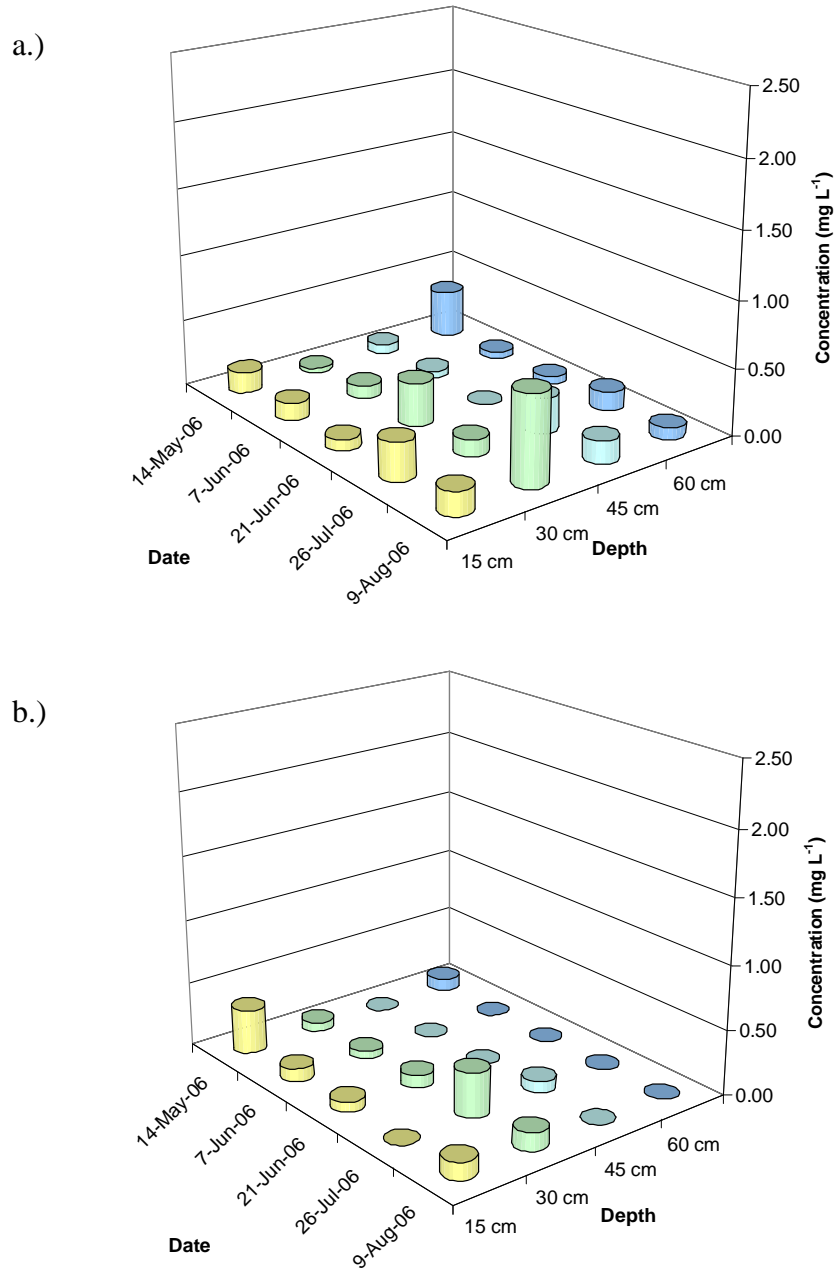

Figure 29. Zinc concentrations ( $\text{mg L}^{-1}$ ) on dates of effluent application by depth at emitter application rate of  $0.72 \text{ L h}^{-1}$  for lysimeters a.) 15 cm and b.) 30 cm from the irrigation tape.

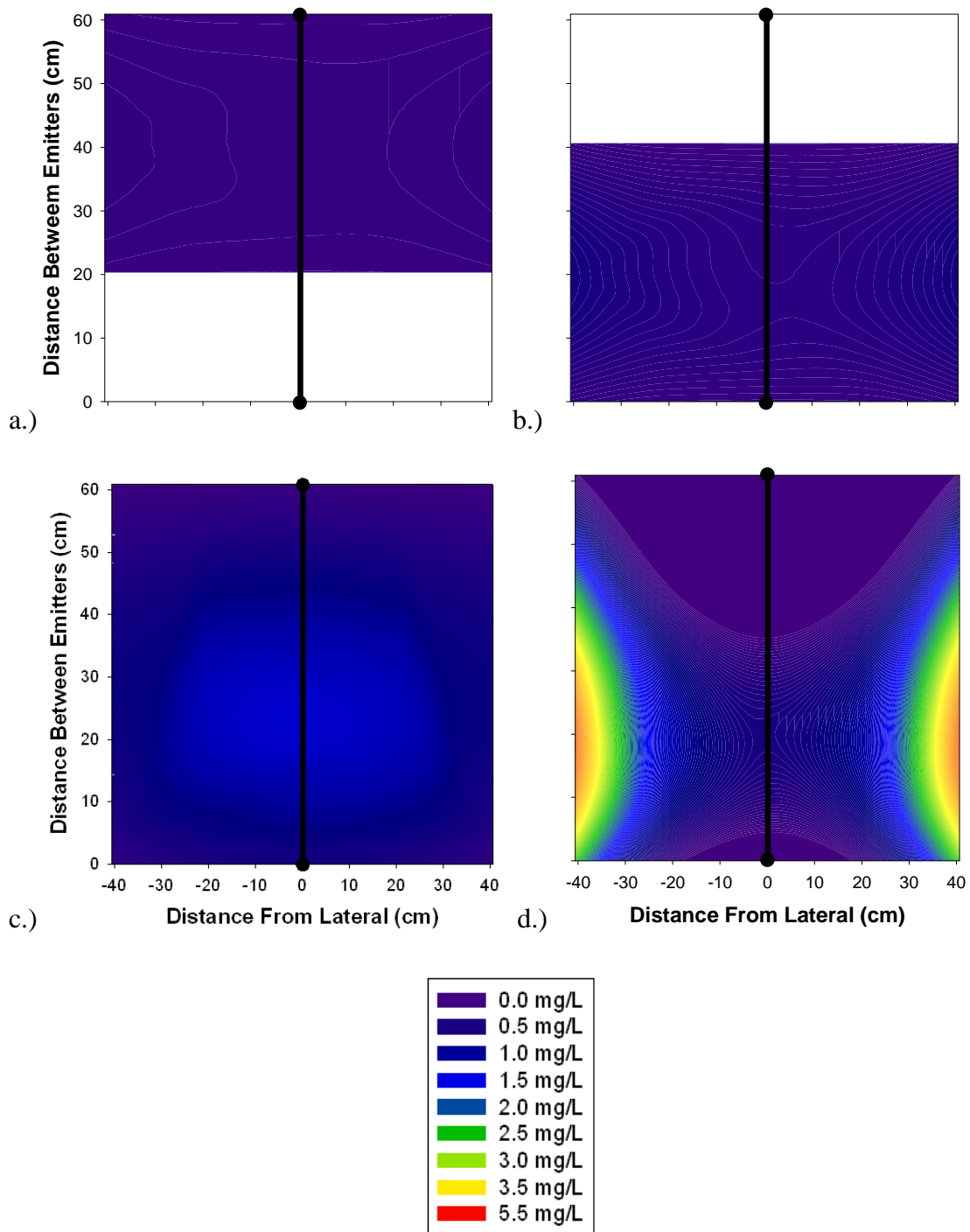

Figure 30. Zinc concentration ( $\text{mg L}^{-1}$ ) on 14 May 2006 from  $2.38 \text{ L h}^{-1}$  emitter application rate at depths of a.) 15 cm, b.) 30 cm, c.) 45 cm, and d.) 60 cm. At 15 and 30 cm depth solution samples were obtained from limited lysimeters resulting in an incomplete graph. Black line located at zero distance from the irrigation tape indicates location of irrigation tape with respect to the x-axis.



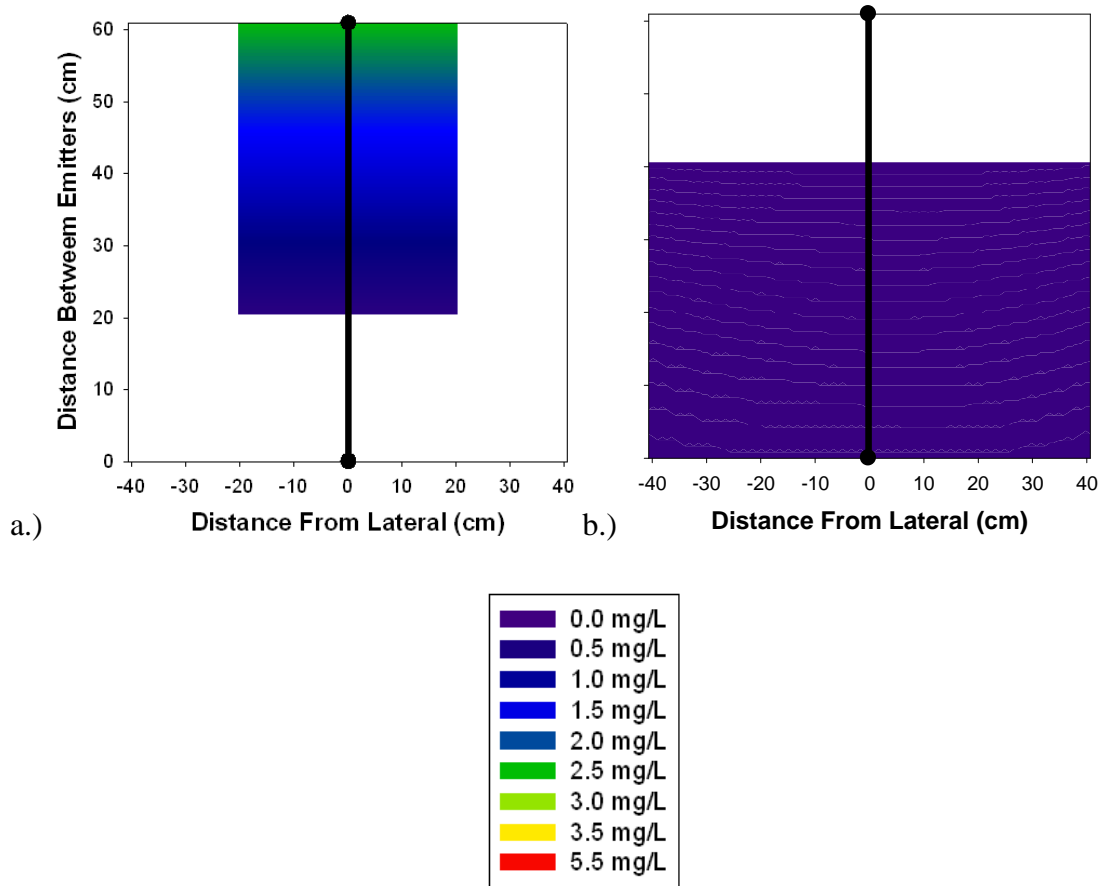

Figure 31. Zinc concentration ( $\text{mg L}^{-1}$ ) on 26 July 2006 from  $2.38 \text{ L h}^{-1}$  emitter application rate at depths of a.) 15 cm and b.) 60 cm. No solution was obtained from lysimeters located at 30 and 45 cm depth no figures were produced. At 15 and 60 cm depth solution samples were obtained from limited lysimeters resulting in an incomplete graph. Black line located at zero distance from the irrigation tape indicates location of irrigation tape with respect to the x-axis.

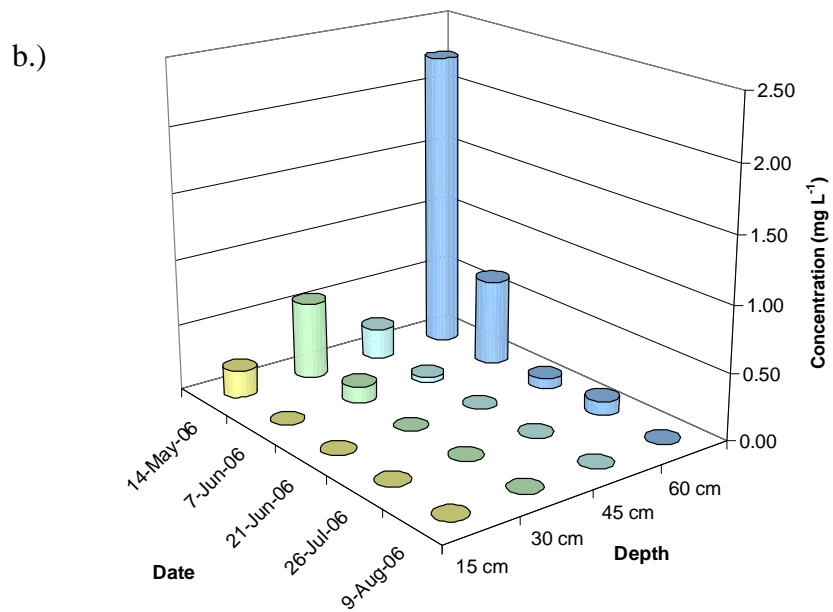
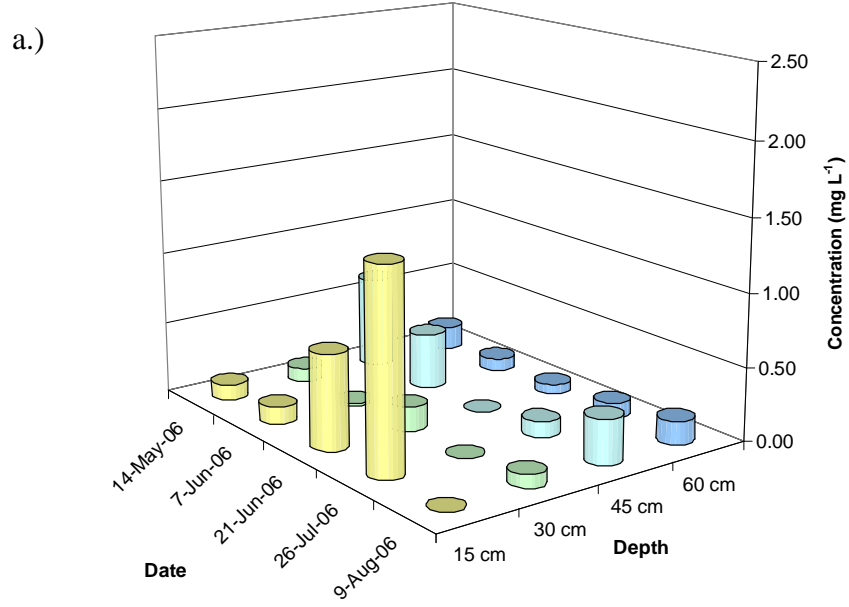

Figure 32. Zinc concentrations ( $\text{mg L}^{-1}$ ) on dates of effluent application by depth at emitter application rate of  $2.38 \text{ L h}^{-1}$  for lysimeters a.) 20 cm and b.) 40 cm from the irrigation tape.

## CONCLUSION

Lysimeter placement is integral to obtaining representative data for the movement of nutrients through the soil profile. In the case of this experiment the ability to sample from multiple depths at each point provides a more detailed analysis for the movement of soil nutrients. A more extensive sampling regime would allow for analysis of the continuous effects of subsurface irrigation throughout the entire growing season and the effects of discontinuing fertigation following the final effluent application event for each year.

At  $0.72 \text{ L h}^{-1}$  emitter application rate  $\text{NO}_3^-$ -N, calcium, and copper were found to be significantly correlated with time indicating accumulation through the growing season. Orthophosphate was found to have a significantly negative correlation with depth signifying decreased movement down through the profile. No significant correlation was found between lysimeter location and concentration for the remaining nutrients measured, indicating uniform dispersion throughout the soil profile or removal at rates approximate to application. At  $2.38 \text{ L h}^{-1}$  emitter application rate a significant increase over time was observed for orthophosphates, copper and calcium concentrations. Nitrate-N concentration was found to be significantly correlated with lysimeter location, increasing with lateral distance, and decreasing with depth. Orthophosphate concentration displayed a significant negative correlation with depth. Calcium, copper, and zinc concentrations were not significantly correlated with lysimeter location with

respect to irrigation tape.

Further testing would determine whether concentrations decrease to background levels after effluent applications have ceased. However, low concentrations prior to initial application indicate levels do decrease resulting from continued irrigation. For this reason the potential for nutrient concentrations to exceed levels toxic to the plants would be unlikely.

## REFERENCES

- Ali, N.A., M.P. Bernal, and M. Ater. 2002. Tolerance and bioaccumulation of copper in *Phragmites australis* and *Zea mays*. *Plant and Soil*. 239:103-111.
- Bacon, P.E. and B.G. Davey. 1982. Nutrient availability under trickle irrigation: I. Distribution of water and Bray no. 1 phosphate. *Soil Sci. Soc. Am. J.* 46:981-987.
- Bar-Yosef, B. and R. Sheikholslami. 1979. Distribution of water and ions in soils irrigated and fertilized from a trickle source. *Soil Sci. Soc. Am. J.* 40:575-582.
- Ben-Gal, A. and L.M. Dudley. 2003. Phosphorus availability under continuous point source irrigation. *Soil Sci. Soc. Am. J.* 67:1449-1456.
- Ben-Gal, A. and N. Lazarovitch. Beyond burying the lateral: Current issues in and future opportunities for subsurface drip irrigation. *Netafim*. (Available on-line at <http://mop.textstore.co.il/data/Subsurface%20drip%20irrigation%202003.pdf>) (Verified 5 January 2007).
- Brumm, M.C. 1998. Sources of manure: Swine. P.49-63. *In* J.L. Hatfield and B.A. Stewart (Ed.) *Animal waste utilization: Effective use of manure as a soil resource*. Ann Arbor Press. Chelsea MI.
- Camp, C.R. 1998. Subsurface drip irrigation: A review. *Transactions of the ASAE*. 41:1353-1367.
- Campos, C., G. Oron, M. Salgot, and L. Gillerman. 2000. Behavior of the fecal pollution indicators in a soil irrigated with treated wastewater under on-surface and subsurface drip irrigation. *Water Sci. Technol.* 42:75-79.

- Charlesworth, P. and W.A. Muirhead. 2003. Crop establishment using subsurface drip irrigation: A comparison of point and area sources. *Irrig. Sci.* 22:171-176.
- Cote, C.M., K.L. Bristow, P.B. Charlesworth, F.J. Cook, and P.J. Thorburn. 2003. Analysis of soil wetting and solute transport in subsurface trickle irrigation. *Irrig. Sci.* 22:143-156.
- Grover, B.L. and R.E. Lamborn. 1970. Preparation of porous ceramic cups to be used for extraction of soil water having low solute concentrations. *Soil Sci. Soc. Am. Pro.* 35:706-708.
- Guru M. V. and J.E. Horne. 2000. *The Ogallala Aquifer*. The Kerr Center. (Available on-line at [http://www.kerrcenter.com/publications/ogallala\\_aquifer.pdf](http://www.kerrcenter.com/publications/ogallala_aquifer.pdf)). (Verified 5 January 2007).
- Hansen, E. A. and A.R. Harris. 1975. Validity of soil-water collected with porous ceramic cups. *Soil Sci. Soc. Am. Proc.* 39:528-536.
- Havlin, J.L., J.D. Beaton, S.L., Tisdale, and W.L. Nelson. *Soil fertility and fertilizers: An introduction to nutrient management* (6<sup>th</sup> ed.). New Jersey: Prentice Hall.
- Haynes, R.J. 1985. Principles of fertilizer use for trickle irrigated crops. *Fert. Res.* 6:235-255.
- Haynes, R.J. 1990. Movement and transformations of fertigated nitrogen below trickle emitters and their effects on pH in the wetted soil volume. *Fert. Res.* 23:105-112.
- Hornbuckle, K.A. 2004. Transports of swine effluent salts when land-applied in a semi-arid region through a subsurface drip irrigation system. M.S. Thesis. Oklahoma State Univ., Stillwater.
- Kafkafi, U. 1994. Combined irrigation and fertilization in arid zones. *Isr. J. Plant Sci.* 42: 301-320.

- Karlen, D.R., J.R. Russel, and A.P. Mallarino. 1998. A systems engineering approach for utilizing animal manure. P. 283-315. *In* J.L. Hatfield and B.A. Stewart (Eds.) Animal waste utilization: Effective use of manure as a soil resource. Ann Arbor Press. Chelsea, MI.
- Kromm, D. E. 2007. Ogallala Aquifer. Water Encyclopedia. (Available on-line at <http://www.waterencyclopedia.com/Oc-Po/Ogallala-Aquifer.html>). (Verified 3 April 2007).
- Laher, M. and Y. Avnimelech. 1980. Nitrification inhibition in drip irrigation systems. *Plant Soil*. 55: 35-42.
- Lamm, F.R. 2002. Advantages and disadvantages of subsurface drip irrigation. International meeting on Advances in Drip/Micro Irrigation, sponsored by Instituto Canario de Investigaciones Agrarias. Puerto de La Cruz, Tenerife, Canary Islands.
- L'Herroux L., S. Le Roux, P. Appriou, and J. Martinez. 1997. Behaviour of metals following intensive pig slurry applications to a natural field treatment process in Brittany (France). *Environ. Pollut.* 97:119-130.
- Li, J. J. Zhang, and M. Rao. 2003. Water and nitrogen distribution as affected by fertigation of ammonium nitrate from a point source. *Irrig. Sci.* 22:19-30.
- Li, J., J. Zhang, and M. Rao. 2004. Wetting patterns and nitrogen distributions as affected by fertigation strategies from surface point source. *Agric. Water Manage.* 67:89-104.
- Lindsay, W. L. 2001. *Chemical Equilibria in Soils*. The Blackburn Press, New Jersey.
- Litaor, M.I. 1988. Review of soil solution samples. *Water Resour. Res.* 24:727-733.
- McGuire, P.E., B. Lowery, and P.A. Helmke. 1992. Potential sampling error: Trace metal adsorption on vacuum porous cup samplers. *Soil Sci. Soc. Am. J.* 56:74-82.

- National Research Council. 1998. Nutrient requirements of swine. 10<sup>th</sup> ed. National Academy Press. Washington D.C.
- Oron, G. 1996. Soil as a complementary treatment component for simultaneous wastewater disposal and reuse. *Water Sci. Technol.* 34:243-252.
- Oron, G., Y. DeMalach, Z. Hoffman, and Y. Manor. 1992. Effect of effluent quality and application method on agriculture productivity and environmental control. *Water Sci. Technol.* 26:1593-1601.
- Oron G., Y. DeMalach, Z. Hoffman, Y. Keren, H. Martman, and N. Plazner. 1991. Wastewater disposal for sub-surface trickle irrigation. *Water Sci. Technol.* 23:2149-2158.
- Parizek, R.R. and B. Lane. 1970. Soil-water sampling using pan and deep pressure-vacuum lysimeters. *J Hydrol.* 11:1-21.
- Phene, C.J. Subsurface drip irrigation offers management advantages. GEOFLOW. (Available on-line at <http://www.geoflow.com/agriculture/phene.htm>). (Verified 5 January 2007)
- Rauschkolb, R.S., D.E. Rolston, R.J. Miller, A.B. Carlton, and R.G. Burau. 1976. Phosphorus fertilization with drip irrigation. *Soil Sci. Soc. Am. J.* 40:68-72.
- Shelef, F. 1991. Wastewater reclamation and water resource management. *Water Sci. Technol.* 24:251-265.
- Soil Survey Staff. 1984. Soil Survey Texas County Oklahoma. U.S. Department of Agriculture, Soil Conservation Services in cooperation with Oklahoma Agricultural Experiment Station.
- Sukkariyah, B., G. Evanylo, and L. Zelazny. 2007. Distribution of copper, zinc, and phosphorus in coastal plain soils receiving repeated liquid biosolids applications. *J. Environ. Qual.* 36:1618-1626.



United States Department of Agriculture, Natural Resources Conservation Service.

2006. Land Resource Regions and Major Land Resource Areas of the United States, the Caribbean, and the Pacific Basin. U.S. Department of Agriculture Handbook 296.

Wolt., J.D. 1994. Soil Solution Chemistry: Applications in Environmental Science and Agriculture. John Wiley & Sons, Inc., New York.

## **APPENDICES**

**APPENDIX A: SOLUTION DATA – 14 MAY 2006**

Analysis results for soil solution collected in field utilizing emitter discharge rates of 2.38 L h<sup>-1</sup> (111-144) and 0.72 L h<sup>-1</sup>(311-344) on 14 May 2006. Samples were taken prior to application of swine effluent for 2006. Dash indicates missing data due to lack of sample collected.

Sampler ID	pH	NO <sub>3</sub> <sup>-</sup>	NH <sub>4</sub> <sup>+</sup>	OP	mg L <sup>-1</sup>				TDS	EC	Vol
		N	N		Ca	Cu	Zn	µS			
111	8.24	38.20	0.12	1.64	184.21	0.02	0.23	726.70	1450.50	10.91	
112	8.74	39.70	0.21	-	206.07	0.01	0.58	-	-	5.31	
113	8.37	59.60	0.90	-	-	-	-	-	-	8.22	
114	8.53	53.70	0.98	2.69	-	-	-	1525.80	3045.51	9.41	
121	8.10	39.60	0.16	1.23	162.11	0.02	0.13	1353.00	2700.60	17.84	
122	8.59	4.50	0.99	1.80	124.46	0.00	1.20	534.30	1066.47	9.26	
123	8.44	26.60	0.06	1.19	129.12	0.01	0.06	1091.30	2178.24	16.11	
124	7.54	17.00	0.00	1.35	123.79	0.01	0.08	1055.10	2105.99	32.71	
131	8.22	3.86	0.04	0.75	113.35	0.02	0.13	974.40	1944.91	12.90	
132	7.59	27.00	1.25	2.69	109.89	0.03	0.11	1546.50	3086.83	30.12	
133	8.03	4.01	0.09	1.54	102.59	0.01	0.19	470.70	939.52	18.75	
134	8.00	9.94	0.03	1.02	66.55	0.01	0.10	708.60	1414.37	18.05	
141	8.53	48.90	0.14	-	-	-	-	-	-	9.37	
142	8.26	3.94	2.65	1.38	148.42	0.02	4.44	1693.40	3380.04	10.14	
143	8.29	15.40	0.07	1.02	94.30	0.02	0.21	426.20	850.70	26.55	
144	8.10	27.90	0.02	0.47	130.68	0.02	0.08	1234.10	2463.27	23.54	
311	7.83	70.40	0.048	1.65	192.09	0.03	0.10	912.90	1822.16	18.77	
312	8.61	28.90	0.385	1.58	157.98	0.02	0.59	598.90	1195.41	11.06	
313	-	-	-	-	-	-	-	-	-	-	
314	8.43	36.00	0.013	1.78	166.98	0.02	0.11	614.50	1226.55	14.59	
321	8.25	7.02	0.106	1.56	147.36	0.02	0.19	596.40	1190.42	12.45	
322	7.83	64.80	0.508	1.50	191.51	0.01	0.66	838.90	1674.45	22.13	
323	8.31	10.60	0.117	1.55	140.98	0.02	0.13	542.60	1083.03	18.52	
324	7.84	25.10	0.000	0.93	123.00	0.02	0.04	643.90	1285.23	22.97	
331	7.95	18.80	0.000	0.97	112.45	0.02	0.07	559.10	1115.97	33.89	
332	8.05	9.39	0.000	2.20	103.18	0.02	0.03	506.90	1011.78	26.10	
333	8.42	33.70	0.110	-	-	-	-	-	-	6.37	
334	8.53	8.73	0.000	-	-	-	-	-	-	9.50	
341	8.57	14.10	0.002	1.29	104.91	0.02	0.07	465.50	929.14	18.72	
342	-	-	-	-	-	-	-	-	-	-	
343	-	-	-	-	-	-	-	-	-	-	
344	-	-	-	-	-	-	-	-	-	-	

## APPENDIX B: RAW SOLUTION DATA – 7 JUNE 2006

Analysis results for soil solution collected in field utilizing emitter discharge rates of 2.38 L h<sup>-1</sup> (111-144) and 0.72 L h<sup>-1</sup> (311-344) on 7 June 2006. Samples were taken immediately following first swine effluent application for 2006.

Sampler ID	pH	NO <sub>3</sub> <sup>-</sup>	NH <sub>4</sub> <sup>+</sup>	OP	Ca	Cu	Zn	TDS	EC	Vol
		N	N							
-----mg L <sup>-1</sup> -----										
									μS	mL
111	8.28	44.60	0.000	2.12	185.13	0.03	0.04	702.40	1402.00	10.52
112	8.28	38.50	0.199	1.33	178.40	0.03	0.13	646.00	1289.42	15.49
113	-	-	-	-	-	-	-	-	-	-
114	-	-	-	-	-	-	-	-	-	-
121	7.53	56.10	0.076	1.96	182.95	0.04	0.02	718.90	1434.93	23.84
122	8.23	17.20	0.510	1.54	174.88	0.03	0.59	604.10	1205.79	10.32
123	-	-	-	-	-	-	-	-	-	-
124	8.17	44.70	0.125	-	155.92	0.02	0.18	609.30	1216.17	10.46
131	7.42	12.20	0.369	1.55	178.89	0.03	0.04	677.00	1351.30	29.72
132	8.24	36.00	1.770	-	281.22	0.02	0.22	887.50	1771.46	11.51
133	8.33	3.06	1.170	1.01	132.46	0.02	0.13	503.30	1004.59	7.65
134	8.55	43.40	1.280	1.20	192.37	0.02	0.03	711.70	1420.56	8.09
141	-	-	-	-	-	-	-	-	-	-
142	8.05	12.00	0.701	1.80	177.18	0.03	1.13	750.00	1497.01	15.55
143	-	-	-	-	-	-	-	-	-	-
144	8.30	38.50	0.002	0.99	141.72	0.02	0.18	631.50	1260.48	14.81
311	-	-	-	-	-	-	-	-	-	-
312	-	-	-	-	-	-	-	-	-	-
313	-	-	-	-	-	-	-	-	-	-
314	8.19	39.90	0.000	2.68	164.88	0.01	0.10	581.90	1161.48	15.55
321	8.03	36.90	0.000	-	183.46	0.00	0.06	616.50	1230.54	9.89
322	-	-	-	-	-	-	-	-	-	-
323	7.97	30.70	0.051	2.13	169.16	0.00	0.21	578.80	1155.29	17.28
324	8.05	15.60	0.089	1.57	136.61	0.00	0.05	583.90	1165.47	21.64
331	7.82	22.50	0.000	0.92	144.15	0.01	0.06	570.50	1138.72	32.40
332	7.65	19.40	0.050	1.73	132.92	0.01	0.17	527.60	1053.09	34.61
333	-	-	-	-	-	-	-	-	-	-
334	7.71	24.50	15.600	1.69	145.10	0.00	0.03	543.60	1085.03	28.10
341	7.63	26.50	0.000	1.48	136.89	0.01	0.05	518.30	1034.53	38.22
342	-	-	-	-	-	-	-	-	-	-
343	8.03	25.80	0.016	1.19	138.12	0.01	0.06	509.50	1016.97	18.62
344	-	-	-	-	-	-	-	-	-	-

### APPENDIX C: AMMONIUM-N CONCENTRATION ON 7 JUNE 2006

AT 0.72 L H<sup>-1</sup>

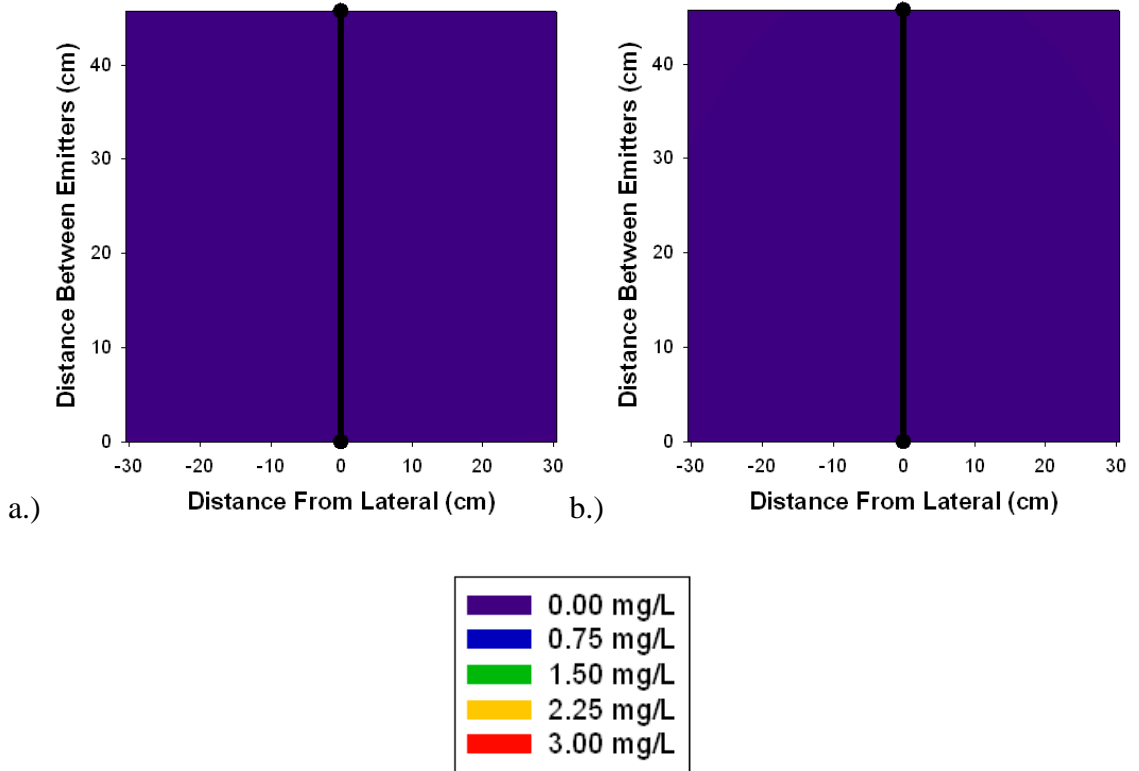

Ammonium-N concentration (mgL<sup>-1</sup>) on 7 June 2006 from 0.72 L h<sup>-1</sup> emitter application rate at depths of a.) 15 cm and b.) 30 cm. No solution was obtained from lysimeters located at 45 and 60 cm depth no figures were produced. Black line located at zero distance from the lateral indicates location of lateral with respect to the x-axis.

**APPENDIX D: AMMONIUM-N CONCENTRATION ON 7 JUNE 2006**

**AT 2.38 L H<sup>-1</sup>**

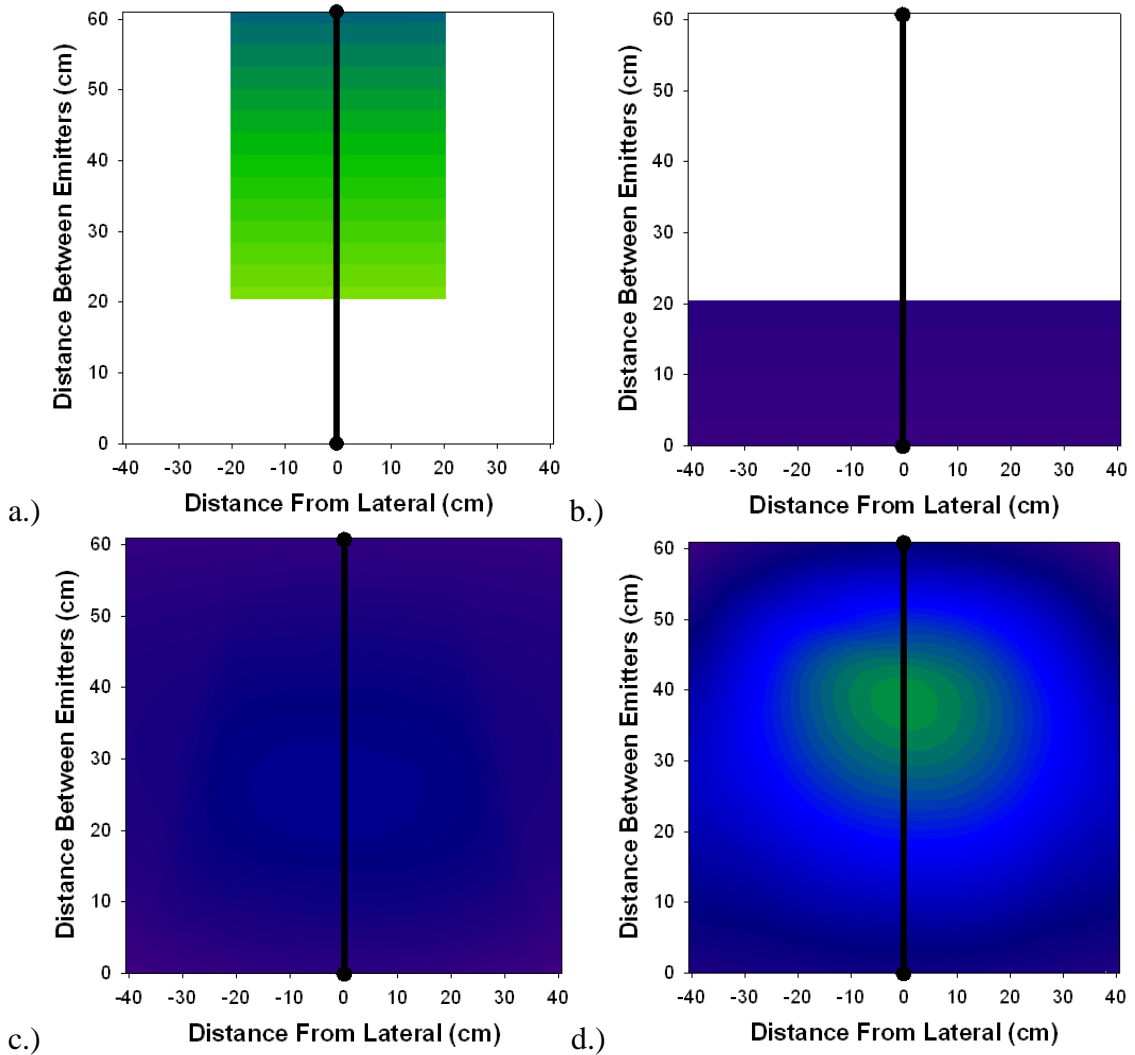

Ammonium-N concentration (mgL<sup>-1</sup>) on 7 June 2007 from 2.38 L h<sup>-1</sup> emitter application rate at depths of a.) 15 cm, b.) 30 cm, c.) 45 cm, and d.) 60 cm. At 15 and 30 cm depths solution samples were obtained from limited lysimeters resulting in incomplete graphs. Black line located at zero distance from the lateral indicates location of lateral with respect to the x-axis.

**APPENDIX E: NITRATE-N CONCENTRATION ON 7 JUNE 2006  
AT 0.72 L H<sup>-1</sup>**

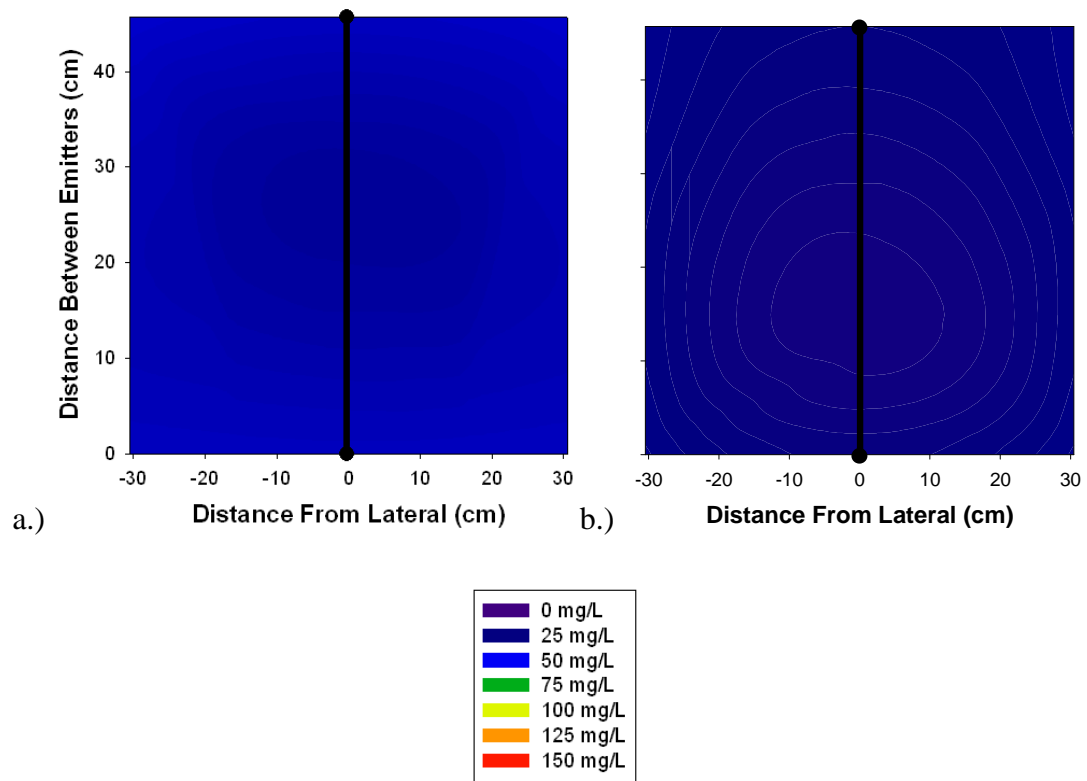

Nitrate-N concentration (mgL<sup>-1</sup>) on 7 June 2006 from 0.72 L h<sup>-1</sup> emitter application rate at depths of a.) 15 cm and b.) 30 cm. No solution was obtained from lysimeters located at 45 and 60 cm depth no figures were produced. Black line located at zero distance from the lateral indicates location of lateral with respect to the x-axis.

**APPENDIX F: NITRATE-N CONCENTRATION ON 7 JUNE 2006  
AT 2.38 L H<sup>-1</sup>**

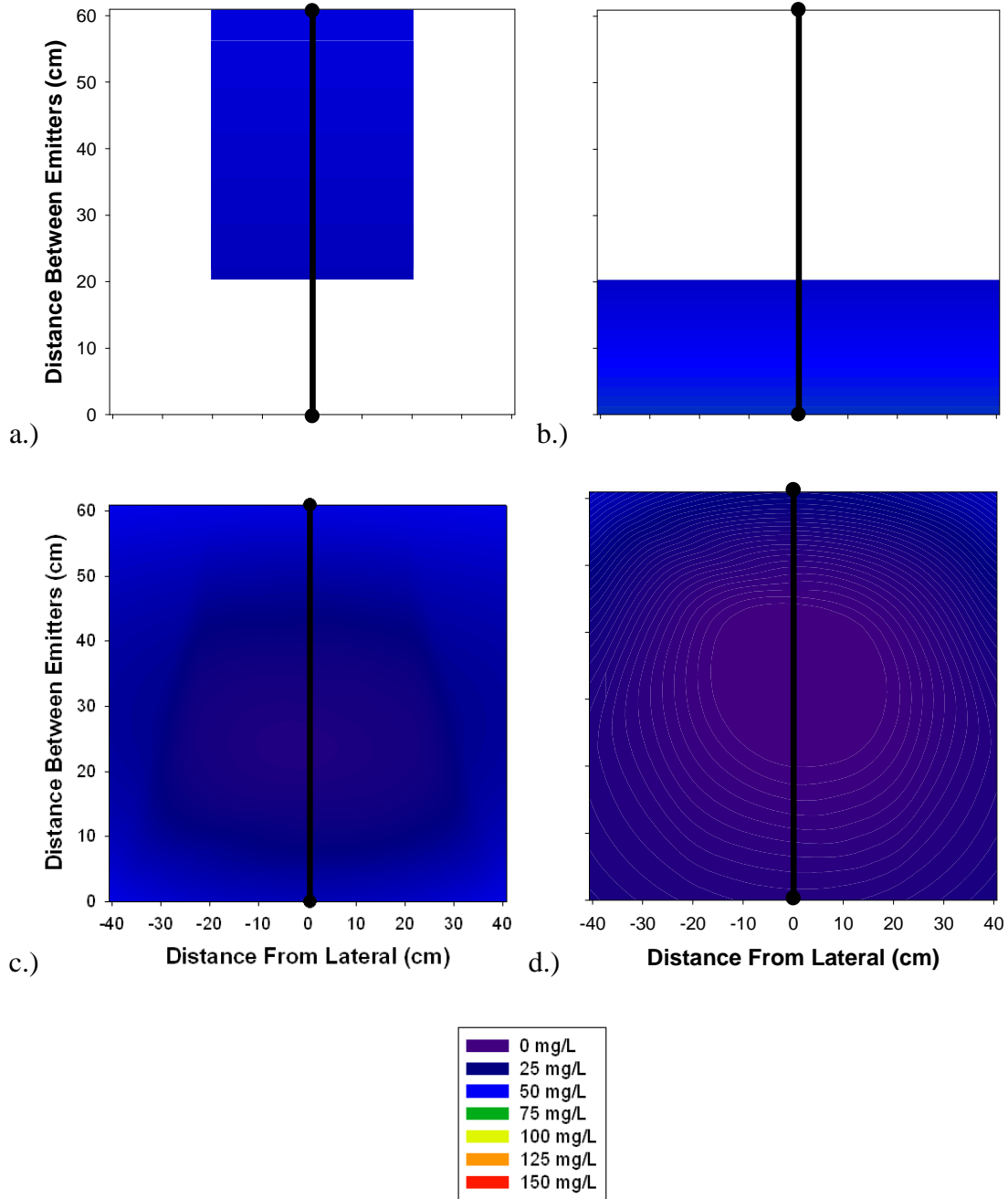

Nitrate-N concentration (mgL<sup>-1</sup>) on 7 June 2006 from 2.38 L h<sup>-1</sup> emitter application rate at depths of a.) 15 cm, b.) 30 cm, c.) 45 cm, and d.) 60 cm. At 15 and 30 cm depths solution samples were obtained from limited lysimeters resulting in incomplete graphs. Black line located at zero distance from the lateral indicates location of lateral with respect to the x-axis.



**APPENDIX G: ORTHOPHOSPHATE CONCENTRATION ON 7 JUNE 2006  
AT 0.72 L H<sup>-1</sup>**

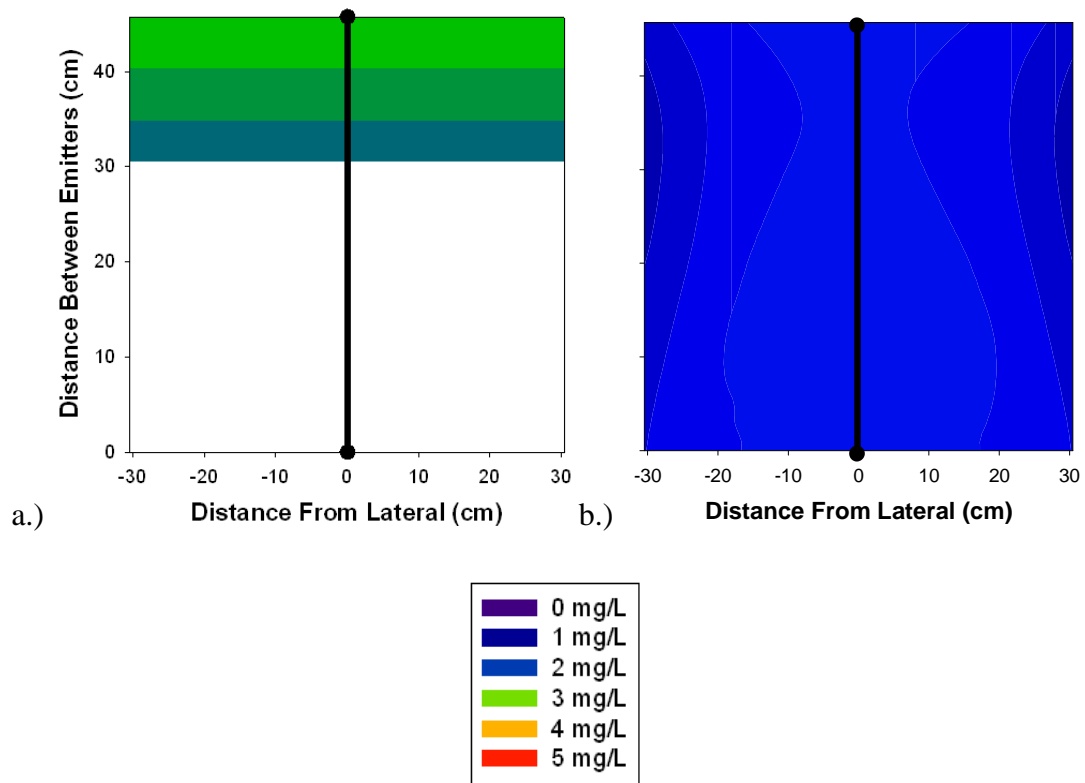

Orthophosphate concentration ( $\text{mgL}^{-1}$ ) on 7 June 2006 from  $0.72 \text{ L h}^{-1}$  emitter application rate at depths of a.) 15 cm and b.) 30 cm. No solution was obtained from lysimeters located at 45 and 60 cm depth. At 30 cm depth solution samples were obtained from limited lysimeters resulting in an incomplete graph. Black line located at zero distance from the lateral indicates location of lateral with respect to the x-axis.

**APPENDIX H: ORTHOPHOSPHATE CONCENTRATION ON 7 JUNE 2006  
AT 2.38 L H<sup>-1</sup>**

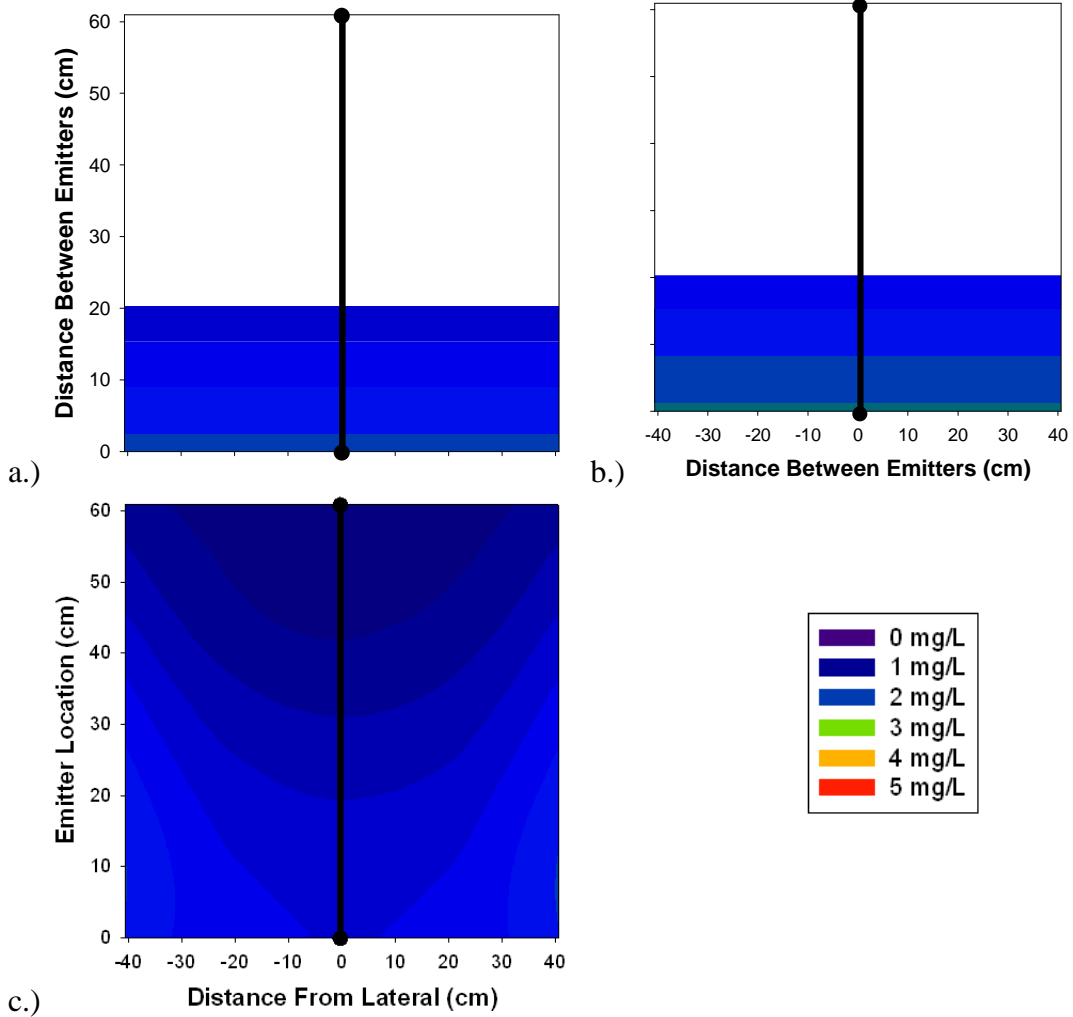

Orthophosphate concentration ( $\text{mgL}^{-1}$ ) on 7 June 2006 from  $2.38 \text{ L h}^{-1}$  emitter application rate at depths of a.) 30 cm, b.) 45 cm, and c.) 60 cm. No solution was obtained from lysimeters located at 15 cm depth. At 30 and 45 cm depth solution samples were obtained from limited lysimeters resulting in an incomplete graph. Black line located at zero distance from the lateral indicates location of lateral with respect to the x-axis.

## APPENDIX I: CALCIUM CONCENTRATION ON 7 JUNE 2006 $0.72 \text{ L H}^{-1}$

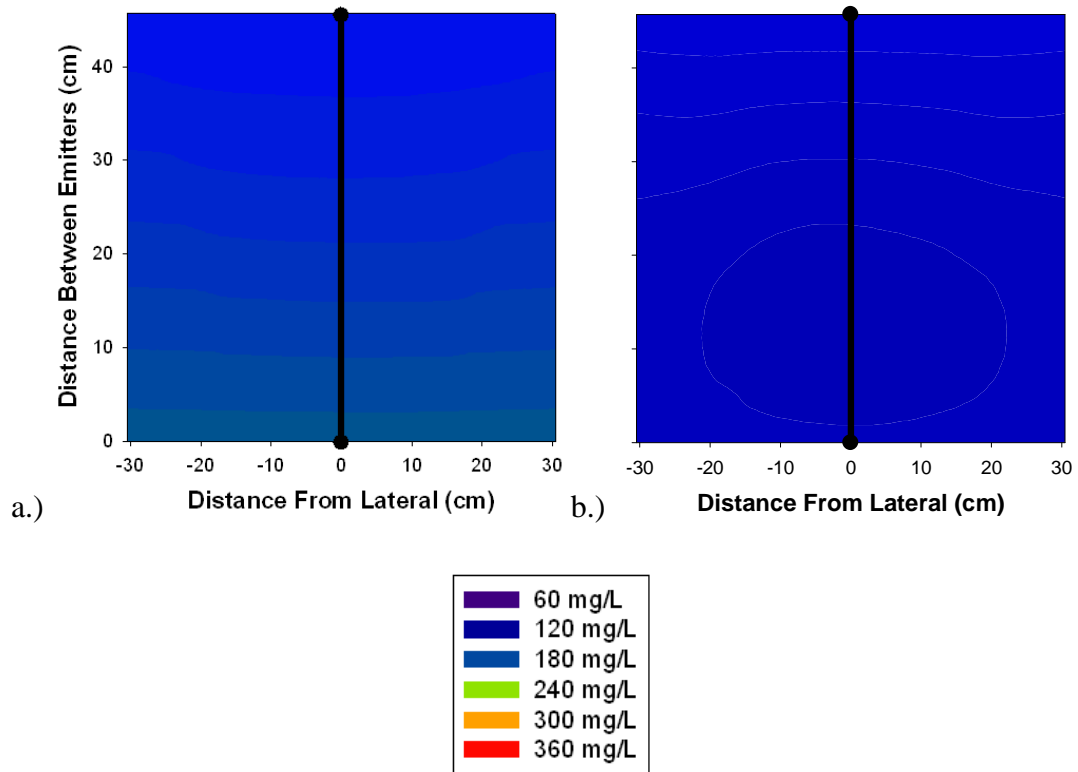

Calcium concentration ( $\text{mgL}^{-1}$ ) on 7 June 2006 from  $0.72 \text{ L h}^{-1}$  emitter application rate at depths of a.) 15 cm and b.) 30 cm. No solution was obtained from lysimeters located at 45 and 60 cm depth no figures were produced. Black line located at zero distance from the lateral indicates location of lateral with respect to the x-axis.

**APPENDIX J: CALCIUM CONCENTRATION ON 7 JUNE 2006 AT 2.38 L H<sup>-1</sup>**

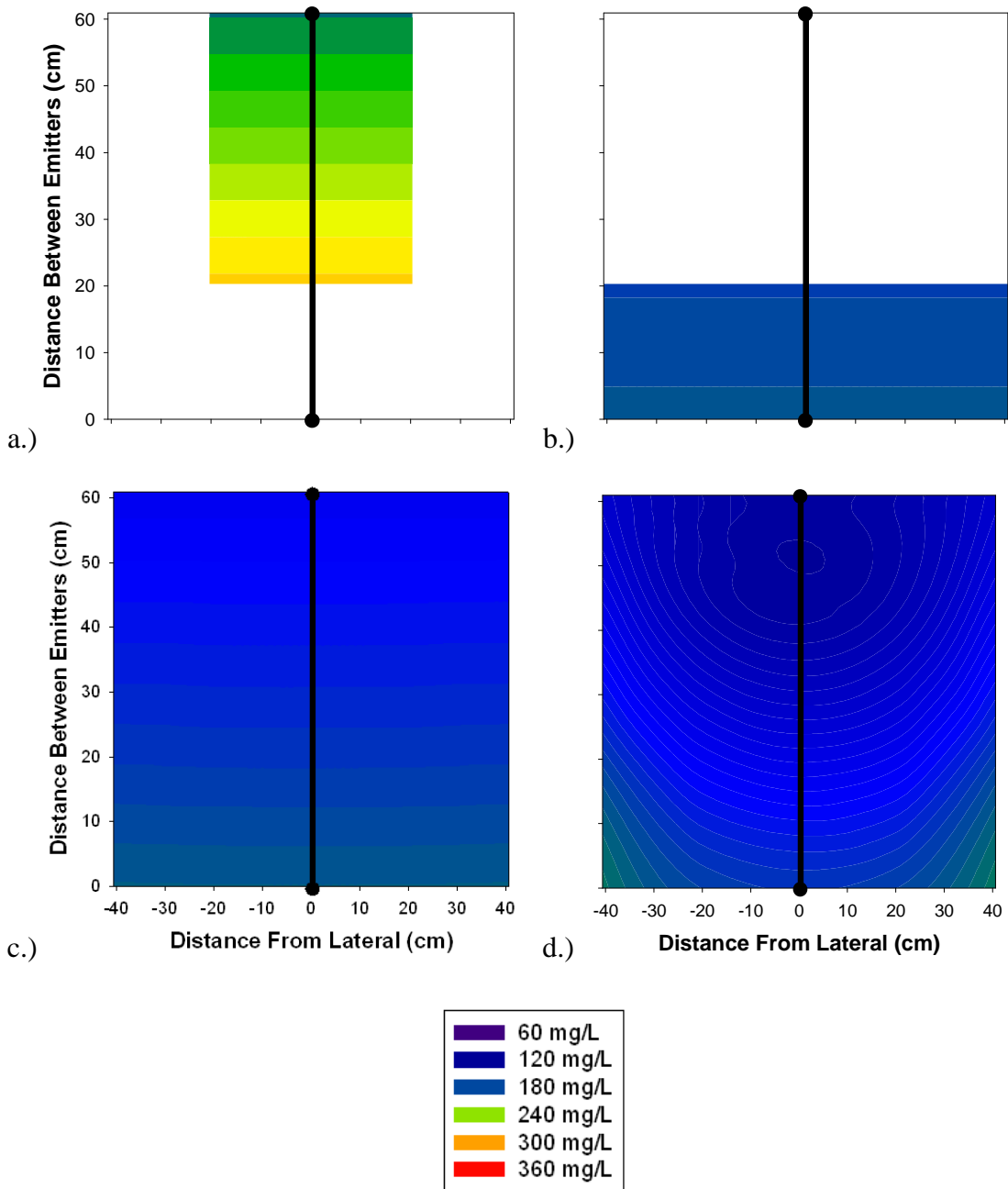

Calcium concentration ( $\text{mgL}^{-1}$ ) on 7 June 2006 from  $2.38 \text{ L h}^{-1}$  emitter application rate at depths of a.) 15 cm, b.) 30 cm, c.) 45 cm, and d.) 60 cm. At 15 and 30 cm depth solution samples were obtained from limited lysimeters resulting in an incomplete graph. Black line located at zero distance from the lateral indicates location of lateral with respect to the x-axis.

**APPENDIX K: COPPER CONCENTRATION ON 7 JUNE 2006 AT 0.72 L H<sup>-1</sup>**

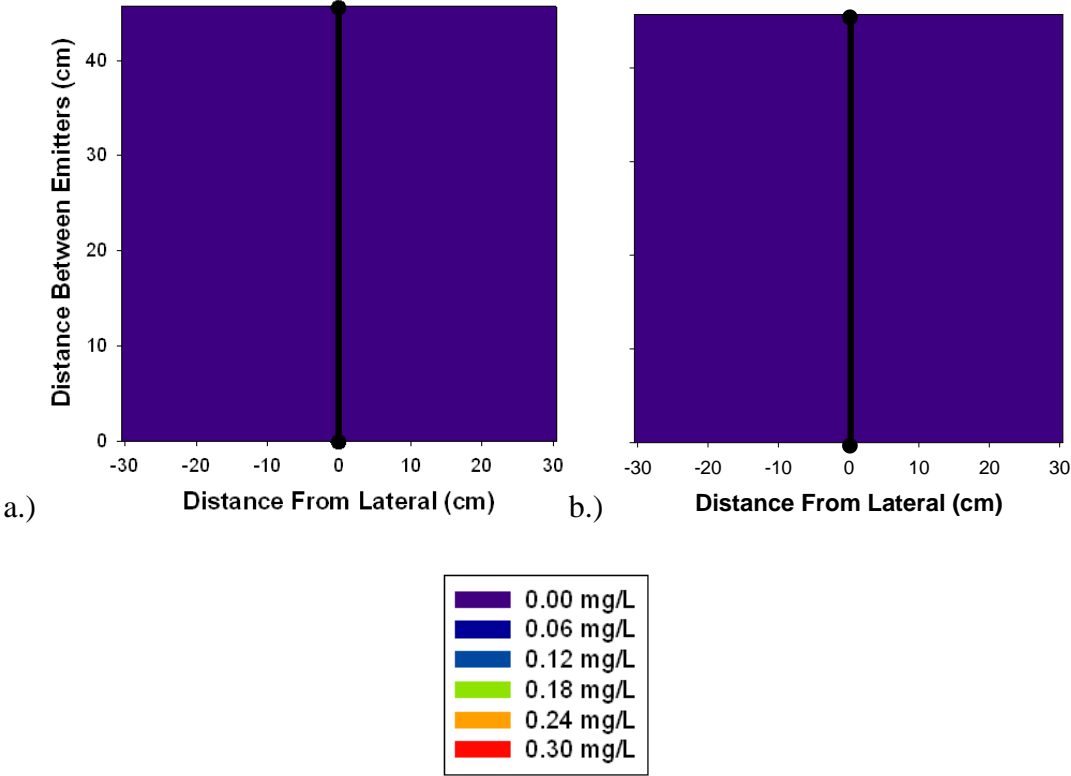

Copper concentration (mgL<sup>-1</sup>) on 7 June 2006 from 0.72 L h<sup>-1</sup> emitter application rate at depths of a.) 15 cm and b.) 30 cm. No solution was obtained from lysimeters located at 45 and 60 cm depth no figures were produced. Black line located at zero distance from the lateral indicates location of lateral with respect to the x-axis.

**APPENDIX L: COPPER CONCENTRATION ON 7 JUNE 2006 AT 2.38 L H<sup>-1</sup>**

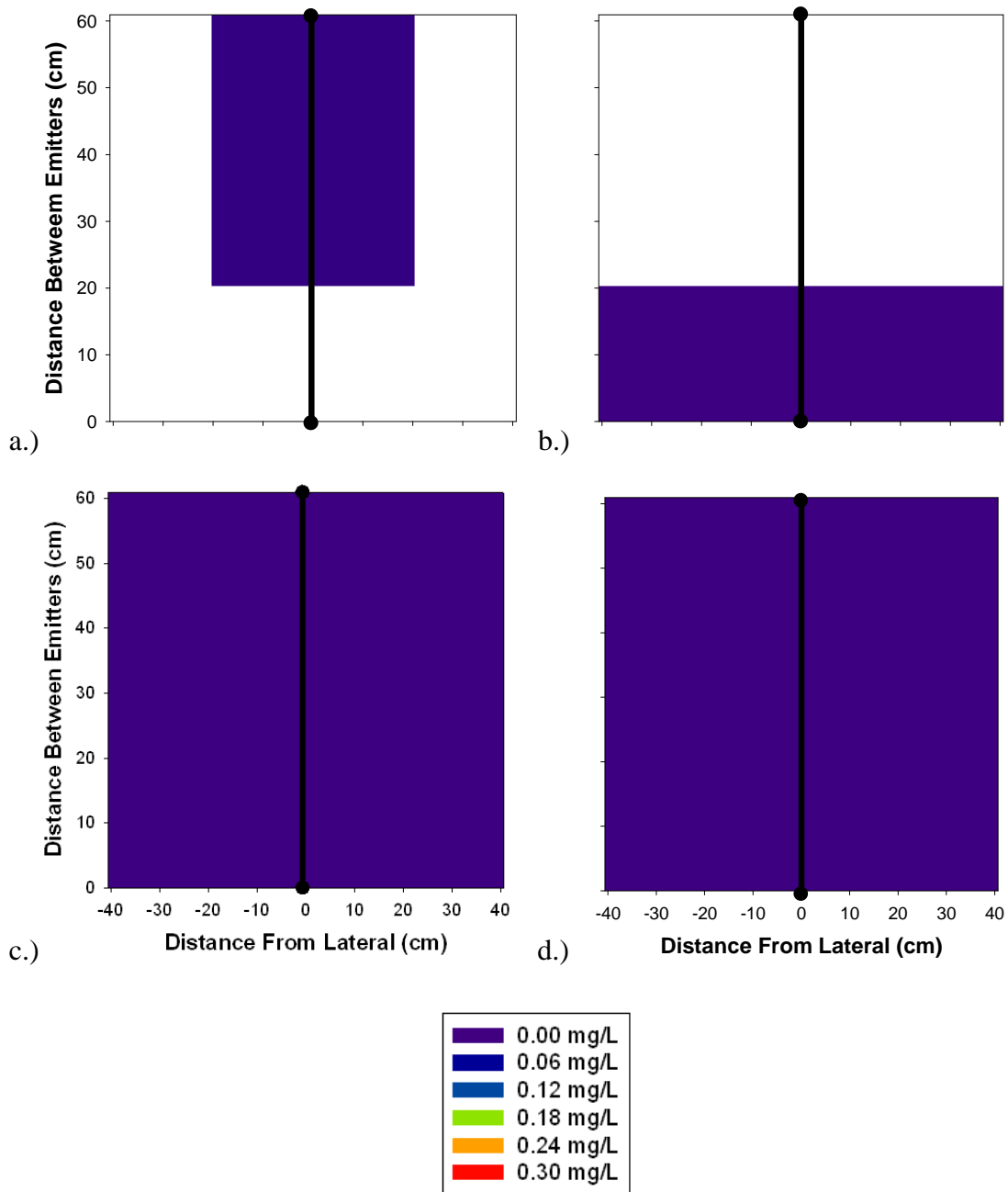

Copper concentration (mgL<sup>-1</sup>) on 7 June 2006 from 2.38 L h<sup>-1</sup> emitter application rate at depths of a.) 15 cm, b.) 30 cm, c.) 45 cm, and d.) 60 cm. At 15 and 30 cm depth solution samples were obtained from limited lysimeters resulting in an incomplete graph. Black line located at zero distance from the lateral indicates location of lateral with respect to the x-axis.

**APPENDIX M: ZINC CONCENTRATION ON 7 JUNE 2006 AT 0.72 L H<sup>-1</sup>**

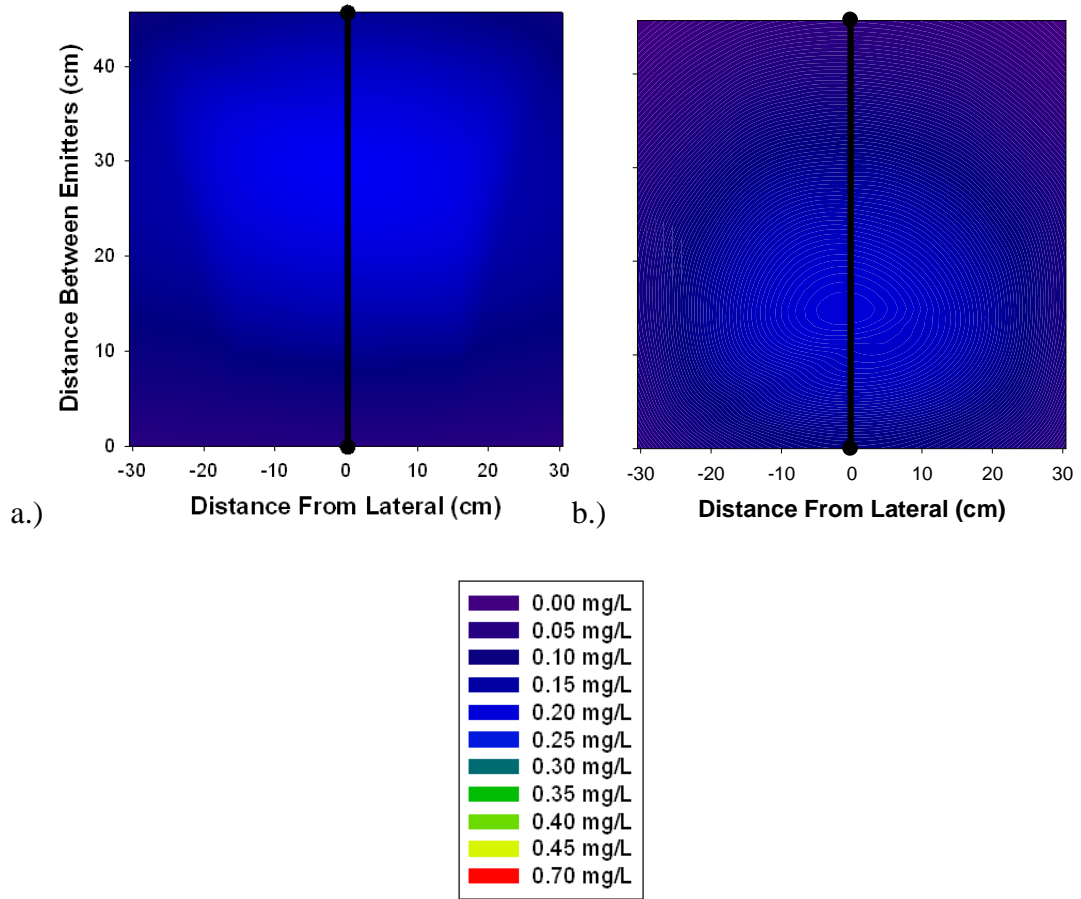

Zinc concentration ( $\text{mgL}^{-1}$ ) on 7 June 2006 from  $0.72 \text{ L h}^{-1}$  emitter application rate at depths of a.) 15 cm and b.) 30 cm. No solution was obtained from lysimeters located at 45 and 60 cm depth no figures were produced. Black line located at zero distance from the lateral indicates location of lateral with respect to the x-axis.

**APPENDIX N: ZINC CONCENTRATION ON 7 JUNE 2006 AT 2.38 L H<sup>-1</sup>**

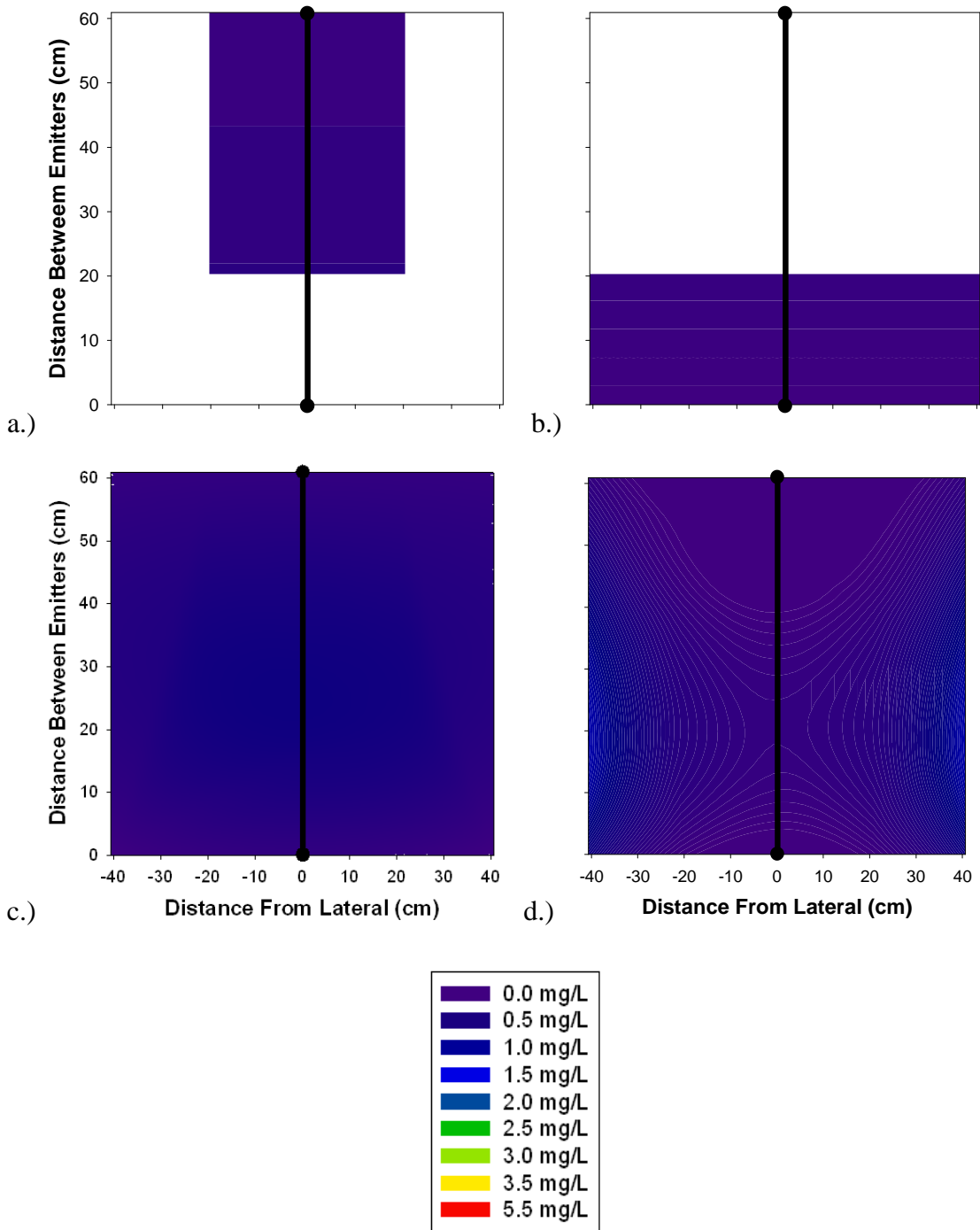

Zinc concentration ( $\text{mgL}^{-1}$ ) on 7 June 2006 from  $2.38 \text{ L h}^{-1}$  emitter application rate at depths of a.) 15 cm, b.) 30 cm, c.) 45 cm, and d.) 60 cm. At 15 and 30 cm depth solution samples were obtained from limited lysimeters resulting in an incomplete graph. Black line located at zero distance from the lateral indicates location of lateral with respect to the x-axis.



**APPENDIX O: RAW SOLUTION DATA – 21 JUNE 2006**

Analysis results for soil solution collected in field utilizing emitter discharge rates of 2.38 L h<sup>-1</sup> (111-144) and 0.72 L h<sup>-1</sup> (311-344) on 21 June 2006. Samples were taken immediately following second swine effluent application of 2006.

Sampler ID	pH	NO <sub>3</sub> <sup>-</sup>	NH <sub>4</sub> <sup>+</sup>	OP	Ca	Cu	Zn	TDS	EC	Vol
		N	N							
-----mg L <sup>-1</sup> -----										
111	-	46.50	7.810	-	-	-	-	-	-	4.63
112	-	-	-	-	-	-	-	-	-	-
113	-	-	-	-	-	-	-	-	-	-
114	-	-	-	-	-	-	-	-	-	-
121	7.71	90.90	0.085	2.18	203.91	0.04	0.04	737.50	1472.06	18.27
122	8.31	34.30	2.050	-	-	-	-	-	-	6.53
123	8.18	61.90	1.150	4.35	257.42	0.07	0.29	681.20	1359.68	10.25
124	-	-	-	-	-	-	-	-	-	-
131	8.22	17.70	0.220	1.41	124.67	0.05	0.06	487.20	972.46	10.40
132	7.78	94.20	0.306	1.90	348.35	0.05	0.08	1039.10	2074.05	16.14
133	-	-	-	-	-	-	-	-	-	-
134	7.85	26.90	0.825	2.11	117.24	0.05	1.23	461.40	920.96	21.12
141	-	-	-	-	-	-	-	-	-	-
142	-	-	-	-	-	-	-	-	-	-
143	-	-	-	-	-	-	-	-	-	-
144	7.98	26.80	0.000	0.92	173.72	0.07	0.08	603.10	1203.79	15.29
311	-	-	-	-	-	-	-	-	-	-
312	-	-	-	-	-	-	-	-	-	-
313	-	-	-	-	-	-	-	-	-	-
314	8.10	8.101	61.50	0.072	252.59	0.07	0.08	707.60	1412.38	12.61
321	7.67	7.665	40.70	0.000	183.63	0.06	0.05	660.50	1318.36	35.48
322	8.03	8.026	101.00	0.013	304.51	0.08	0.06	909.80	1815.97	15.38
323	8.20	8.204	87.30	0.180	243.71	0.08	0.10	751.00	1499.00	15.70
324	-	-	-	-	-	-	-	-	-	-
331	-	-	-	-	-	-	-	-	-	-
332	7.70	7.698	113.00	0.137	241.25	0.11	0.44	820.30	1637.33	39.50
333	-	-	-	-	-	-	-	-	-	-
334	7.66	7.661	78.70	0.049	210.77	0.09	0.22	701.30	1399.80	38.80
341	7.76	7.764	74.00	0.012	206.25	0.08	0.06	693.60	1384.43	26.16
342	-	-	-	-	-	-	-	-	-	-
343	8.08	8.083	42.30	0.000	176.60	0.10	0.13	612.90	1223.35	20.60
344	-	-	-	-	-	-	-	-	-	-

APPENDIX P: AMMONIUM-N CONCENTRATION ON 21 JUNE 2006

AT 0.72 L H<sup>-1</sup>

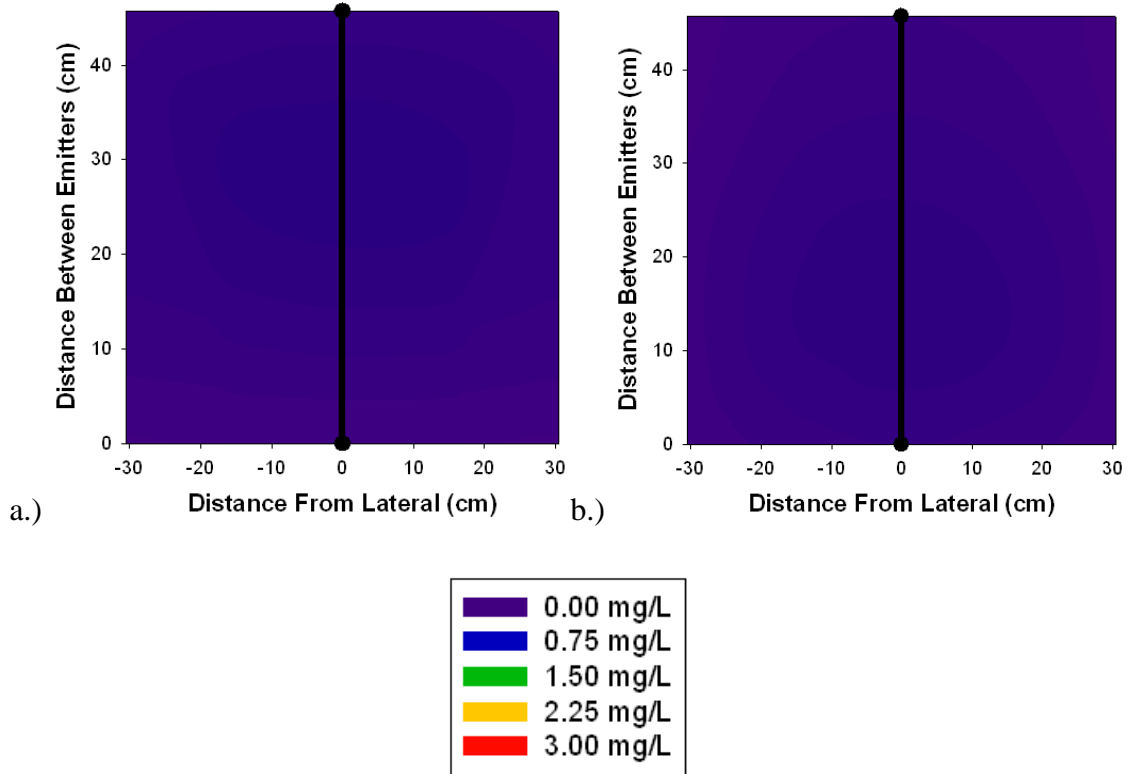

Ammonium-N concentration (mgL<sup>-1</sup>) on 21 June 2006 from 0.72 L h<sup>-1</sup> emitter application rate at depths of a.) 15 cm and b.) 30 cm. No solution was obtained from lysimeters located at 45 and 60 cm depth no figures were produced. Black line located at zero distance from the lateral indicates location of lateral with respect to the x-axis.

**APPENDIX Q: AMMONIUM-N CONCENTRATION ON 21 JUNE 2006  
AT 2.38 L H<sup>-1</sup>**

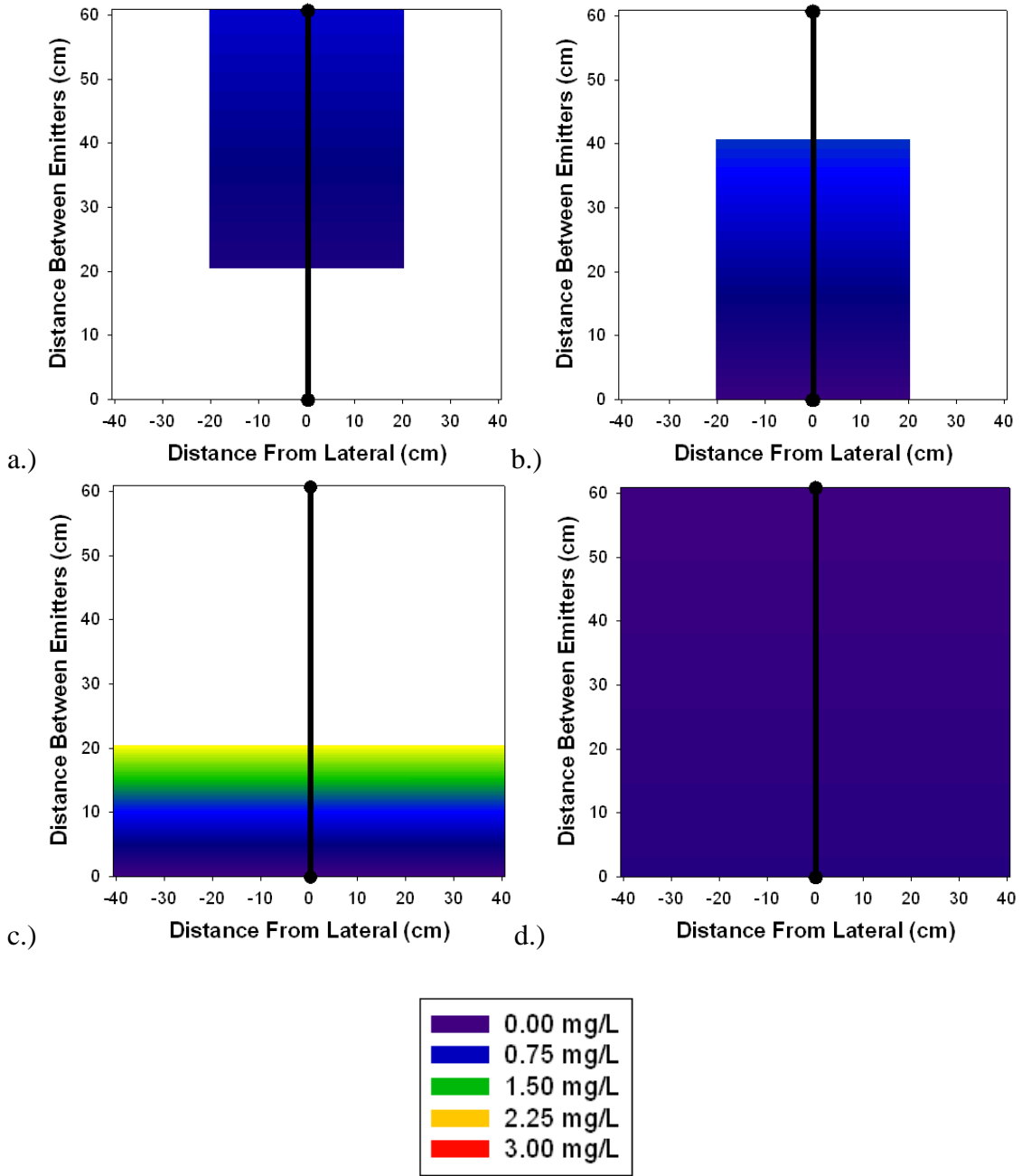

Ammonium-N concentration (mgL<sup>-1</sup>) on 21 June 2006 from 2.38 L h<sup>-1</sup> emitter application rate at depths of a.) 15 cm, b.) 30 cm, c.) 45 cm, and d.) 60 cm. At 15, 30 and 45 cm depths solution samples were obtained from limited lysimeters resulting in incomplete graphs. Black line located at zero distance from the lateral indicates location of lateral with respect to the x-axis.

APPENDIX R: NITRATE-N CONCENTRATION ON 21 JUNE 2006  
AT 0.72 L H<sup>-1</sup>

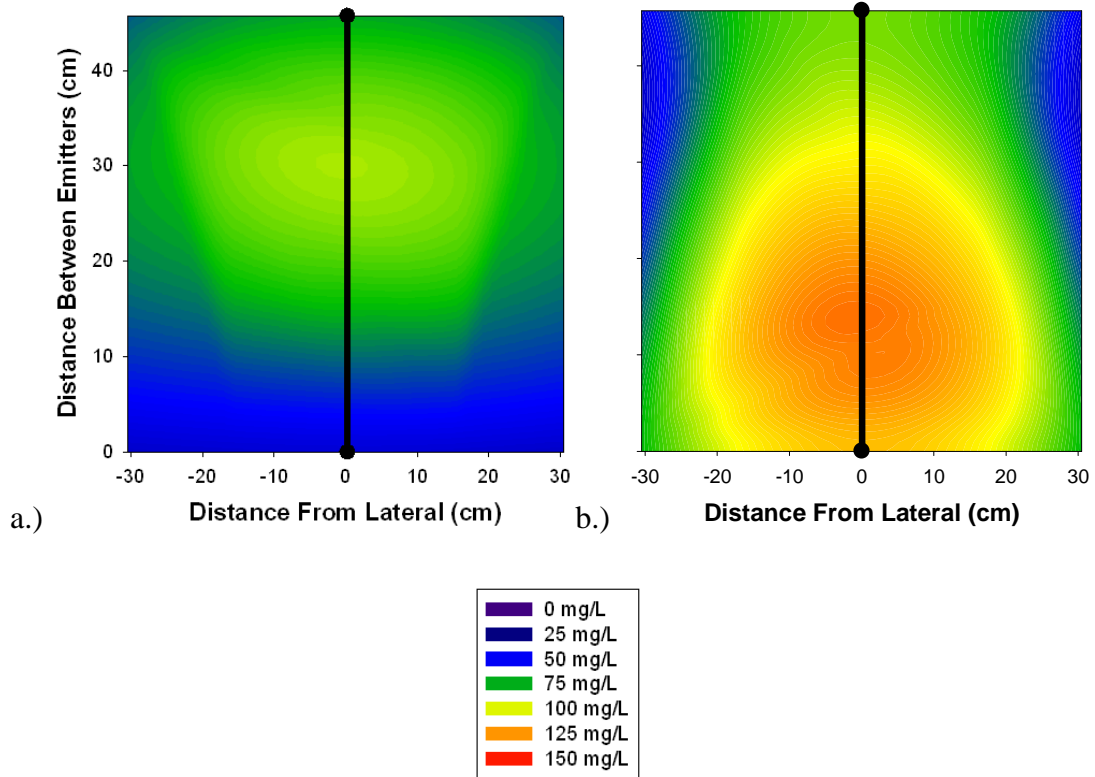

Nitrate-N concentration ( $\text{mgL}^{-1}$ ) on 21 June 2006 from  $0.72 \text{ L h}^{-1}$  emitter application rate at depths of a.) 15 cm and b.) 30 cm. No solution was obtained from lysimeters located at 45 and 60 cm depth no figures were produced. Black line located at zero distance from the lateral indicates location of lateral with respect to the x-axis.

**APPENDIX S: NITRATE-N CONCENTRATION ON 21 JUNE 2006  
AT 0.72 L H<sup>-1</sup>**

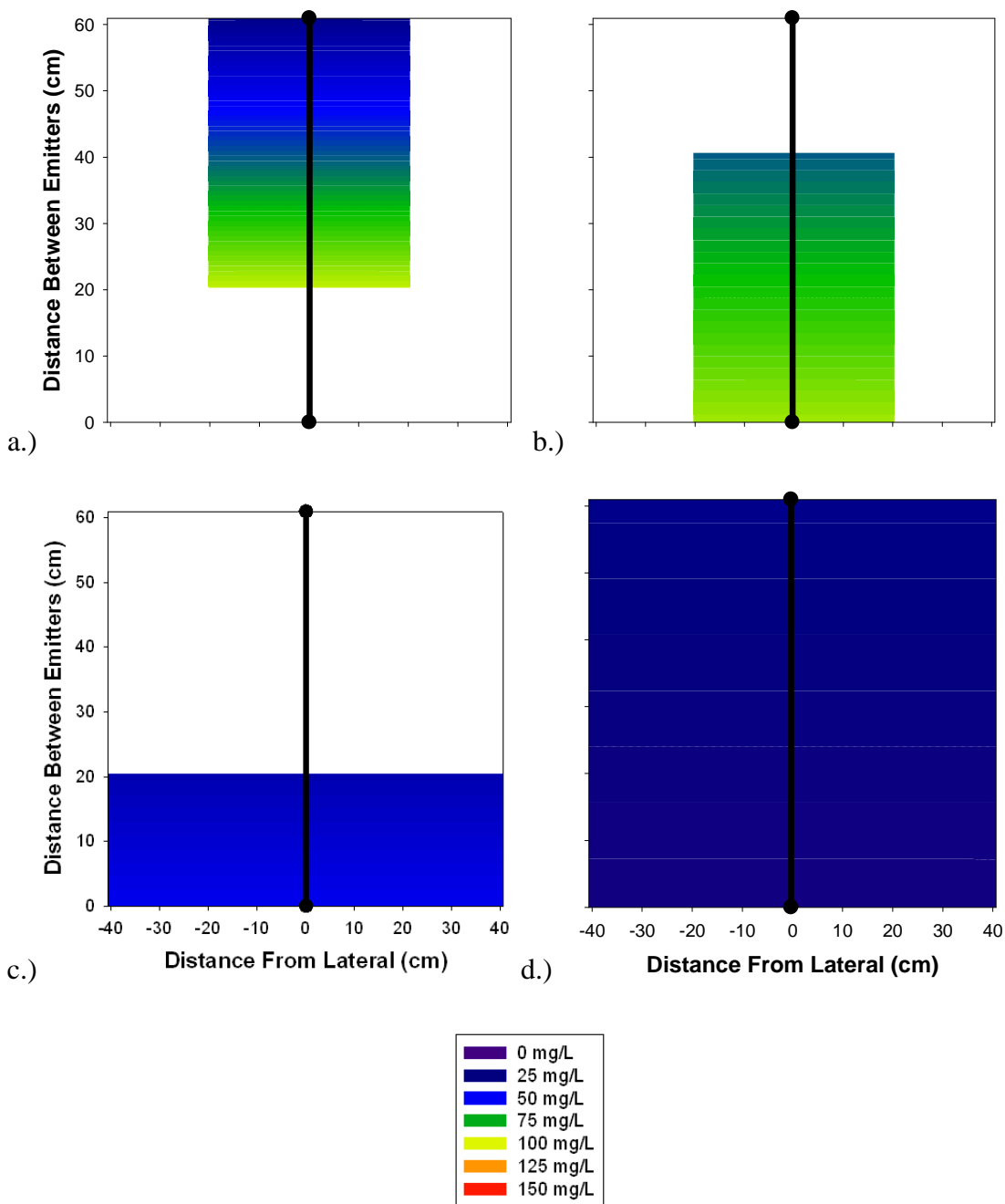

Nitrate-N concentration (mgL<sup>-1</sup>) on 21 June 2006 from 2.38 L h<sup>-1</sup> emitter application rate at depths of a.) 15 cm, b.) 30 cm, c.) 45 cm, and d.) 60 cm. At 15, 30 and 45 cm depths solution samples were obtained from limited lysimeters resulting in incomplete graphs. Black line located at zero distance from the lateral indicates location of lateral with respect to the x-axis.

**APPENDIX T: ORTHOPHOSPHATE CONCENTRATION ON 21 JUNE 2006**

**AT 0.72 L H<sup>-1</sup>**

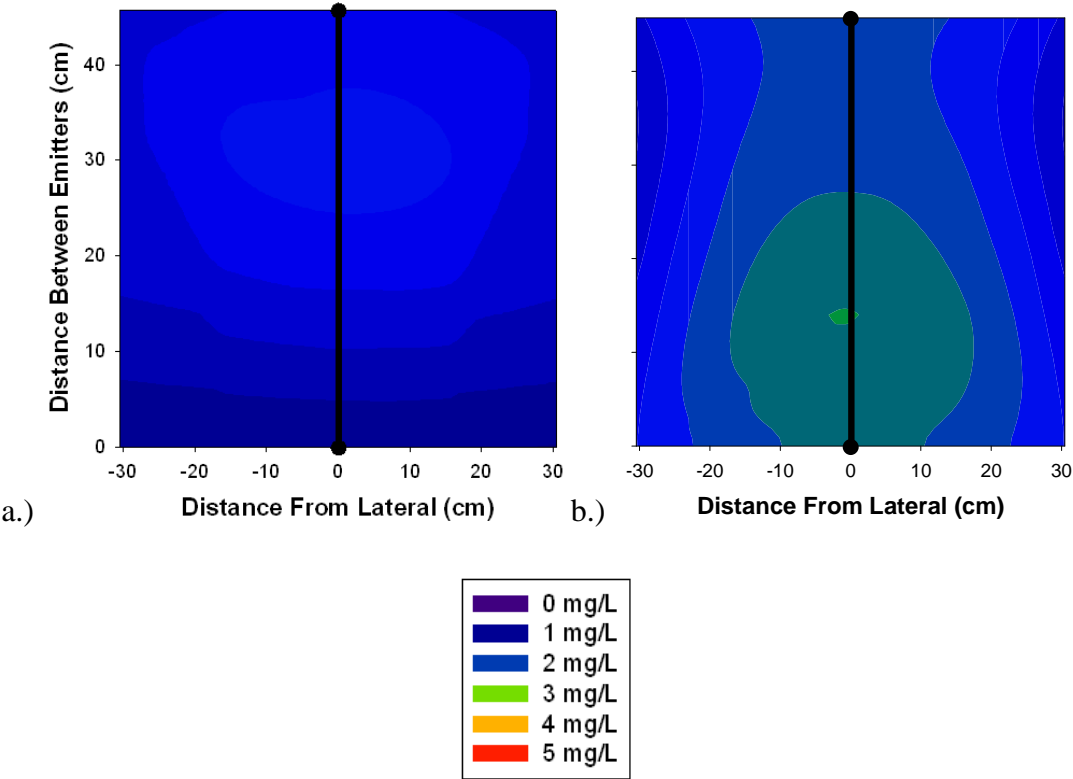

Orthophosphate concentration (mgL<sup>-1</sup>) on 21 June 2006 from 0.72 L h<sup>-1</sup> emitter application rate at depths of a.) 15 cm and b.) 30 cm. No solution was obtained from lysimeters located at 45 and 60 cm depth no figures were produced. Black line located at zero distance from the lateral indicates location of lateral with respect to the x-axis.

**APPENDIX U: ORTHOPHOSHATE CONCENTRATION ON 21 JUNE 2006  
AT 2.38 L H<sup>-1</sup>**

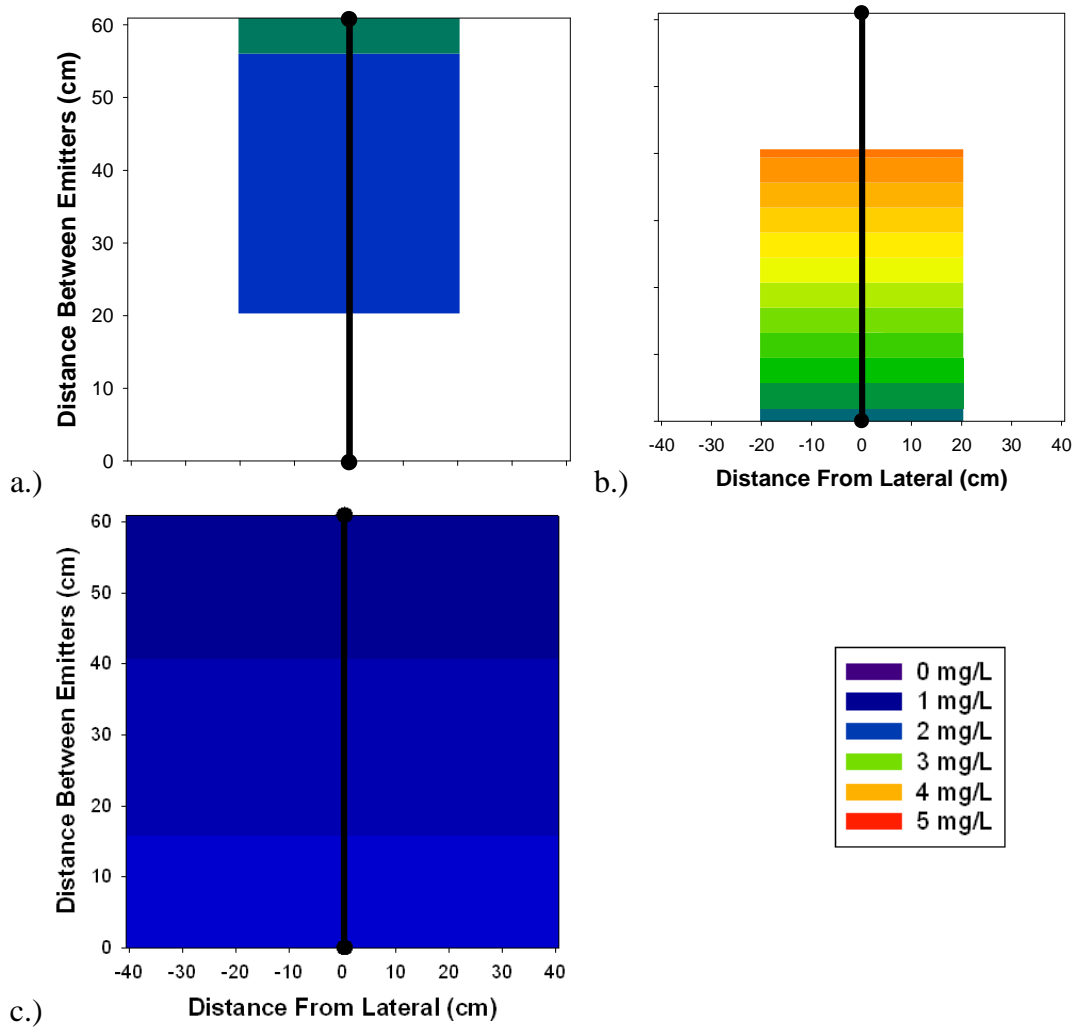

Orthophosphate concentration (mgL<sup>-1</sup>) on 21 June 2006 from 2.38 L h<sup>-1</sup> emitter application rate at depths of a.) 15 cm, b.) 30 cm, c.) 60 cm. No solution was obtained from lysimeters located at 45 cm depth. At 15 and 30 cm depth solution samples were obtained from limited lysimeters resulting in an incomplete graph. Black line located at zero distance from the lateral indicates location of lateral with respect to the x-axis.

## APPENDIX V: CALCIUM CONCENTRATION ON 21 JUNE 2006 AT 0.72 L H<sup>-1</sup>

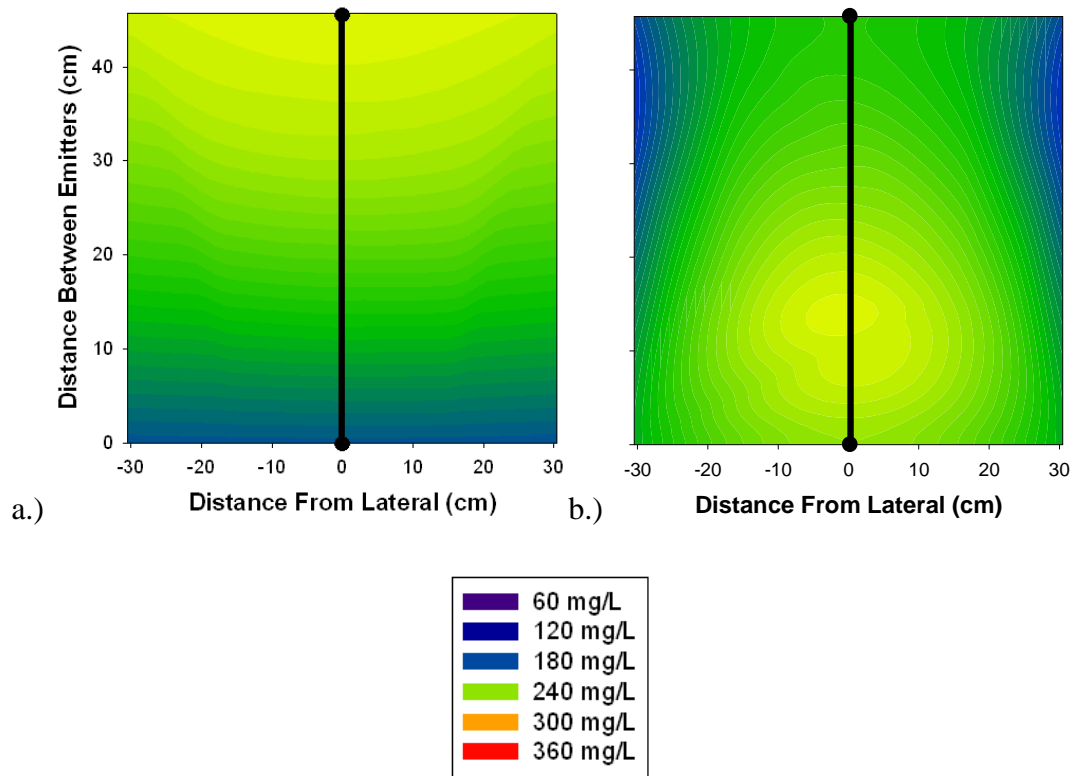

Calcium concentration ( $\text{mgL}^{-1}$ ) on 21 June 2007 from  $0.72 \text{ L h}^{-1}$  emitter application rate at depths of a.) 15 cm and b.) 30 cm. No solution was obtained from lysimeters located at 45 and 60 cm depth no figures were produced. Black line located at zero distance from the lateral indicates location of lateral with respect to the x-axis.



**APPENDIX W: CALCIUM CONCENTRATION ON 21 JUNE 2007 AT 2.38 L H<sup>-1</sup>**

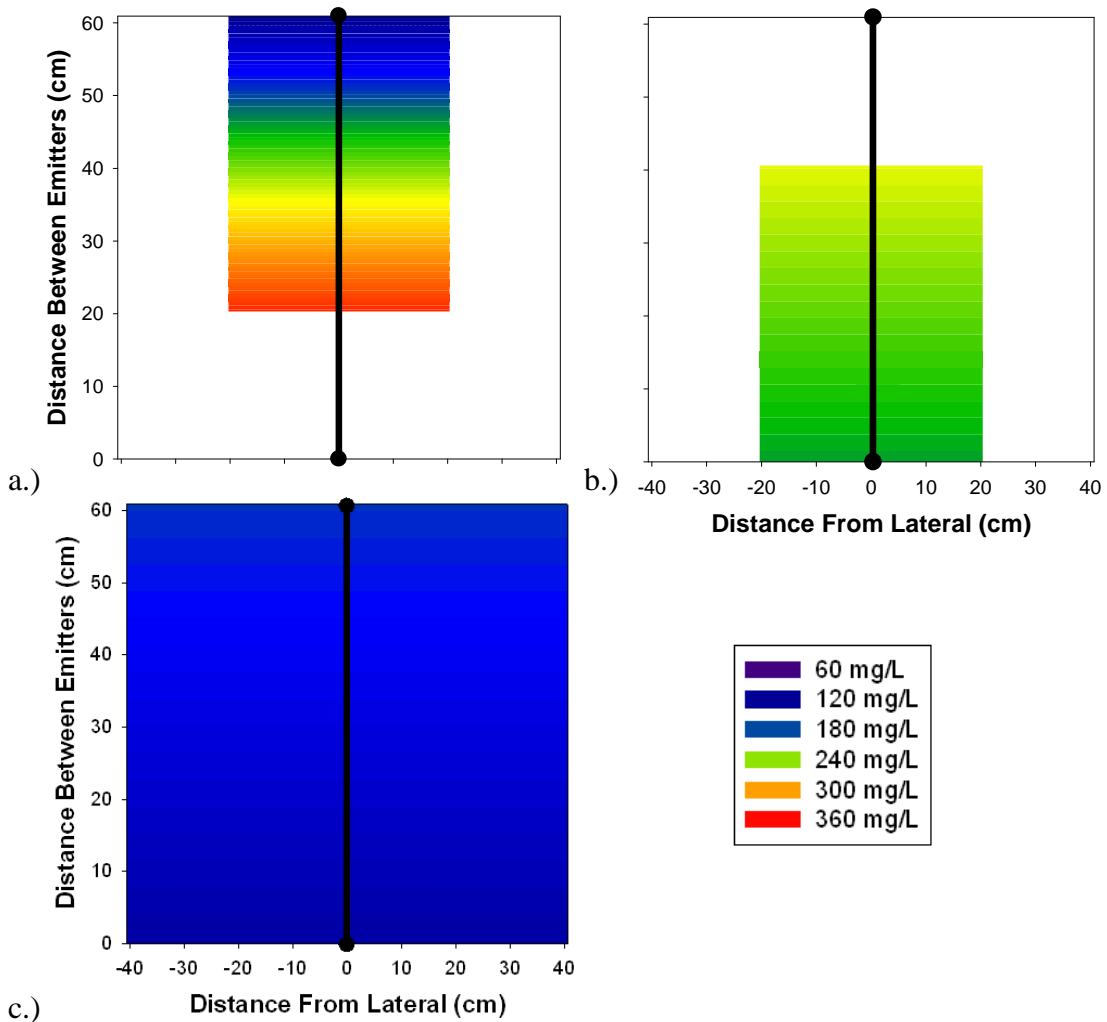

Calcium concentration ( $\text{mgL}^{-1}$ ) on 21 June 2006 from  $2.38 \text{ L h}^{-1}$  emitter application rate at depths of a.) 15 cm, b.) 30 cm, and c.) 60 cm. No solution was obtained from lysimeters located at 45 cm depth. At 15 and 30 cm depth solution samples were obtained from limited lysimeters resulting in an incomplete graph. Black line located at zero distance from the lateral indicates location of lateral with respect to the x-axis.

## APPENDIX X: COPPER CONCENTRATION ON 21 JUNE 2006 AT 0.72 L H<sup>-1</sup>

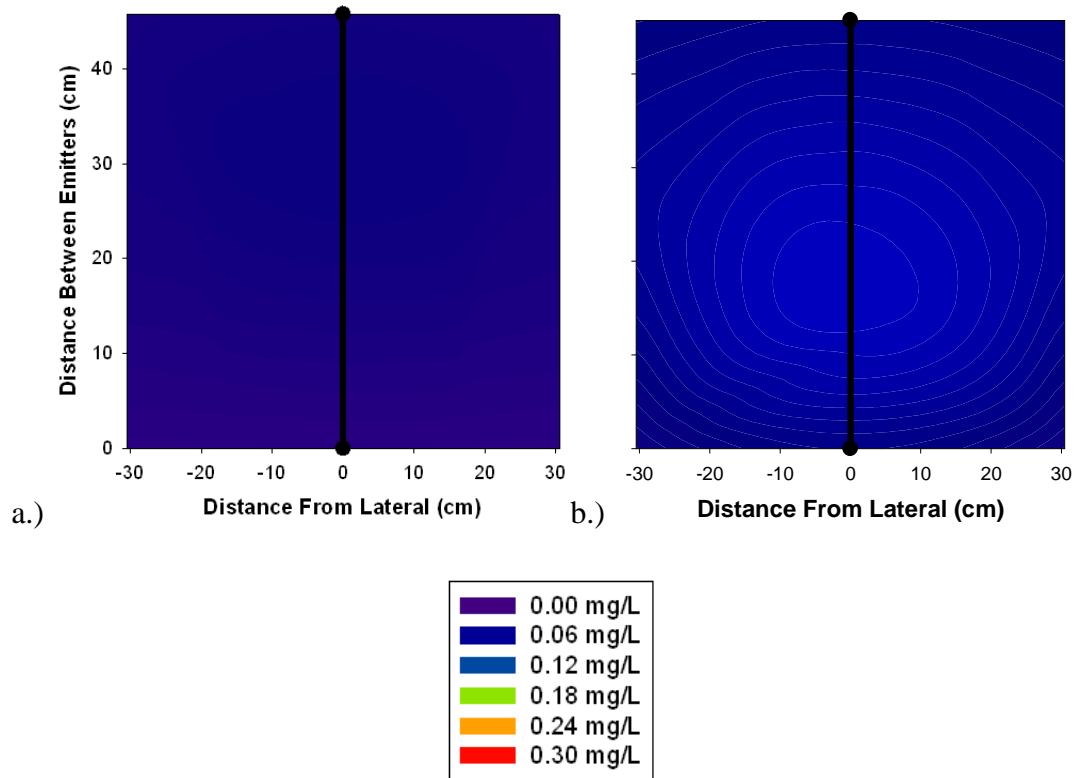

Copper concentration ( $\text{mgL}^{-1}$ ) on 21 June 2006 from  $0.72 \text{ L h}^{-1}$  emitter application rate at depths of a.) 15 cm and b.) 30 cm. No solution was obtained from lysimeters located at 45 and 60 cm depth no figures were produced. Black line located at zero distance from the lateral indicates location of lateral with respect to the x-axis.

**APPENDIX Y: COPPER CONCENTRATION ON 21 JUNE 2006 AT 2.38 L H<sup>-1</sup>**

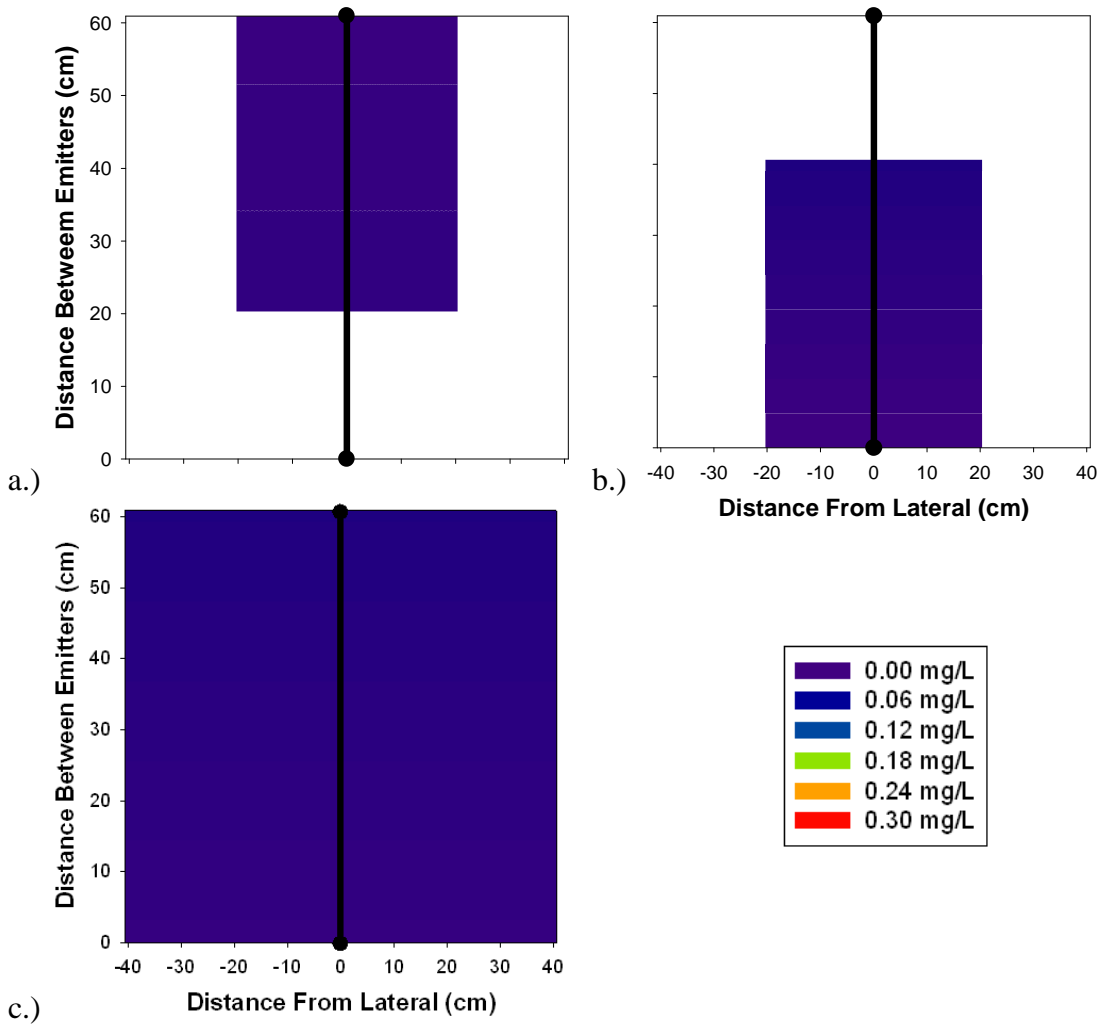

Copper concentration ( $\text{mgL}^{-1}$ ) on 21 June 2007 from  $2.38 \text{ L h}^{-1}$  emitter application rate at depths of a.) 15 cm, b.) 30 cm, and c.) 60 cm. No solution was obtained from lysimeters located at 45 cm depth. At 15 and 30 cm depth solution samples were obtained from limited lysimeters resulting in an incomplete graph. Black line located at zero distance from the lateral indicates location of lateral with respect to the x-axis.

## APPENDIX Z: ZINC CONCENTRATION ON 21 JUNE 2006 AT 0.72 L H<sup>-1</sup>

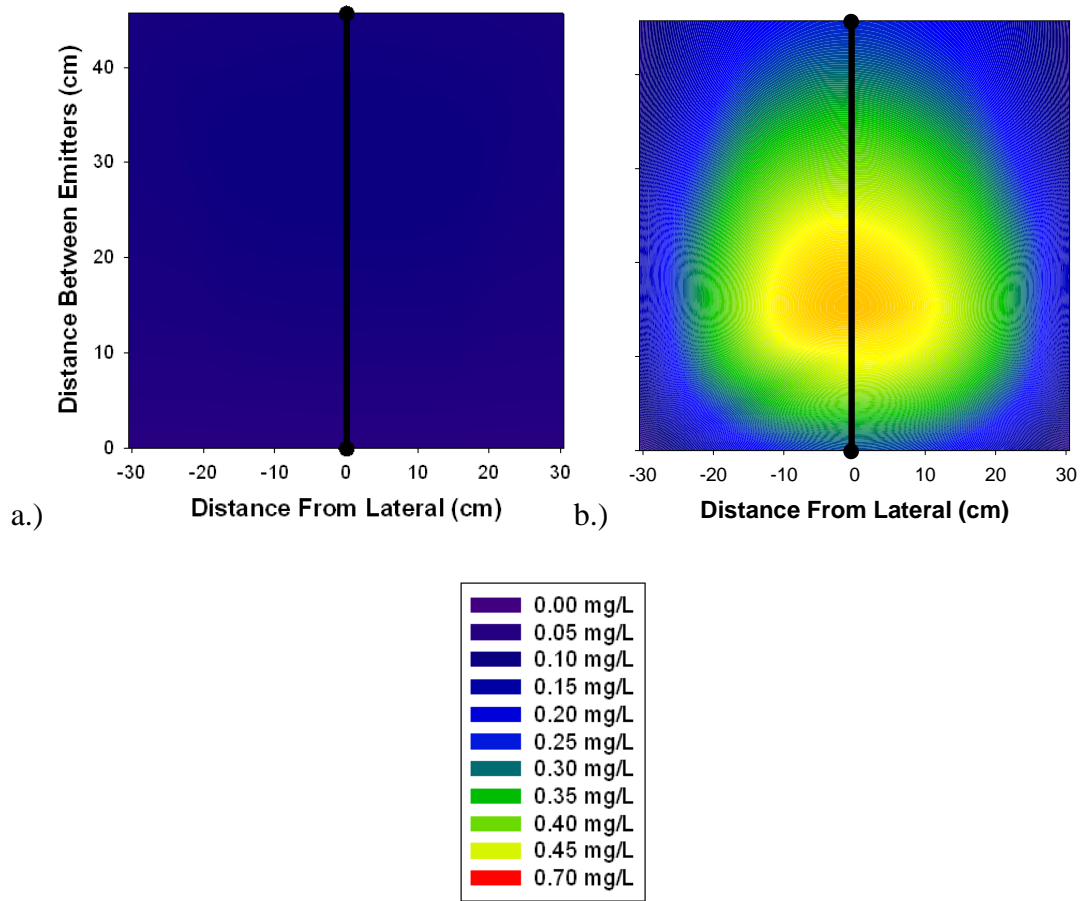

Zinc concentration ( $\text{mgL}^{-1}$ ) on 21 June 2006 from  $0.72 \text{ L h}^{-1}$  emitter application rate at depths of a.) 15 cm and b.) 30 cm. No solution was obtained from lysimeters located at 45 and 60 cm depth no figures were produced. Black line located at zero distance from the lateral indicates location of lateral with respect to the x-axis.

**APPENDIX AA: ZINC CONCENTRATION ON 21 JUNE 2006 AT 2.38 L H<sup>-1</sup>**

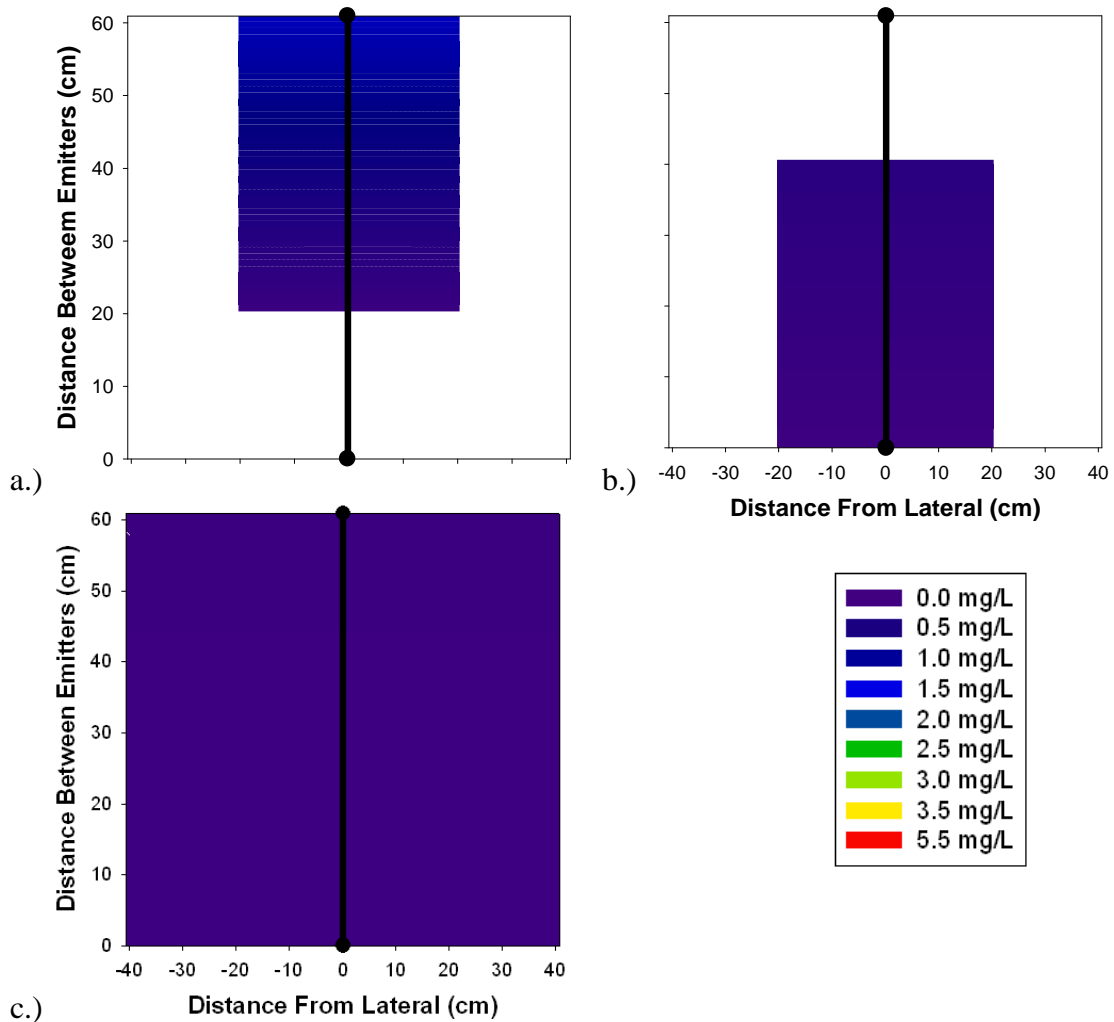

Zinc concentration (mgL<sup>-1</sup>) on 21 June 2006 from 2.38 L h<sup>-1</sup> emitter application rate at depths of a.) 15 cm, b.) 30 cm, and c.) 60 cm. No solution was obtained from lysimeters located at 45 cm depth. At 15 and 30 cm depth solution samples were obtained from limited lysimeters resulting in an incomplete graph. Black line located at zero distance from the lateral indicates location of lateral with respect to the x-axis.

**APPENDIX BB: RAW SOLUTION DATA – 26 JULY 2006**

Analysis results for soil solution collected in field utilizing emitter discharge rates of 2.38 L h<sup>-1</sup> (111-144) and 0.72 L h<sup>-1</sup> (311-344) on 26 July 2006. Samples were collected immediately following third application of effluent of 2006.

Sampler ID	pH	NO <sub>3</sub> <sup>-</sup>	NH <sub>4</sub> <sup>+</sup>	OP	Ca	Cu	Zn	TDS	EC	Vol
		N	N							
-----mg L <sup>-1</sup> -----										
									μS	mL
111	-	-	-	-	-	-	-	-	-	-
112	-	-	-	-	-	-	-	-	-	-
113	-	-	-	-	-	-	-	-	-	-
114	-	-	-	-	-	-	-	-	-	-
121	-	-	-	-	-	-	-	-	-	-
122	8.05	-	-	2.83	-	-	-	-	-	4.51
123	-	-	-	-	-	-	-	-	-	-
124	7.74	101.00	0.087	1.35	301.64	0.22	0.11	1014.80	2025.55	27.49
131	7.41	9.80	0.000	1.56	180.00	0.25	0.12	576.20	1150.10	43.08
132	7.79	2.70	0.124	1.70	208.89	0.24	0.29	647.60	1292.61	15.52
133	7.40	5.40	0.350	1.17	191.14	0.26	0.08	645.50	1288.42	37.57
134	7.78	-	-	3.93	170.53	0.25	2.49	557.60	1112.97	9.41
141	-	-	-	-	-	-	-	-	-	-
142	7.72	26.10	0.104	1.45	247.39	0.26	0.11	831.70	1660.08	22.79
143	-	-	-	-	-	-	-	-	-	-
144	-	-	-	-	-	-	-	-	-	-
311	-	-	-	-	-	-	-	-	-	-
312	-	-	-	-	-	-	-	-	-	-
313	-	-	-	-	-	-	-	-	-	-
314	-	-	-	-	-	-	-	-	-	-
321	-	-	-	-	-	-	-	-	-	-
322	7.34	35.90	0.000	1.24	172.75	0.26	0.08	678.60	1354.49	42.18
323	7.66	26.20	0.206	2.67	204.35	0.25	0.29	642.90	1283.23	12.60
324	7.53	23.20	0.000	1.16	148.77	0.28	0.21	632.60	1262.67	42.02
331	7.51	53.10	0.085	1.11	188.49	0.29	0.26	713.20	1423.55	42.71
332	7.49	50.80	0.096	1.58	198.18	0.28	0.13	693.10	1383.43	28.25
333	-	-	-	-	-	-	-	-	-	-
334	7.47	44.90	0.000	1.64	178.64	0.28	0.13	625.80	1249.10	32.13
341	7.40	60.00	0.000	1.84	177.95	0.28	0.44	617.60	1232.73	42.37
342	-	-	-	-	-	-	-	-	-	-
343	7.55	52.60	0.000	2.09	199.45	0.29	0.27	637.20	1271.86	22.87
344	7.59	54.50	0.000	1.29	175.03	0.25	0.09	686.30	1369.86	43.02

**APPENDIX CC: RAW SOLUTION DATA – 9 AUGUST 2006**

Analysis results for soil solution collected in field utilizing emitter discharge rates of 2.38 L h<sup>-1</sup> (111-144) and 0.72 L h<sup>-1</sup> (311-344) on 9 August 2006. Samples were collected immediately following the fourth and final effluent application of 2006.

Sampler ID	pH	NO <sub>3</sub> <sup>-</sup>	NH <sub>4</sub> <sup>+</sup>	OP	Ca	Cu	Zn	TDS	EC	Vol
		N	N							
-----mg L <sup>-1</sup> -----										
									μS	mL
111	-	-	-	-	-	-	-	-	-	-
112	-	-	-	-	-	-	-	-	-	-
113	-	-	-	-	-	-	-	-	-	-
114	-	-	-	-	-	-	-	-	-	-
121	7.52	1.98	0.227	1.49	172.32	0.27	0.12	561.20	1120.16	25.57
122	-	-	-	-	-	-	-	-	-	-
123	-	-	-	-	-	-	-	-	-	-
124	7.70	42.90	0.134	1.28	241.20	0.26	0.15	798.10	1593.01	21.25
131	7.32	12.00	0.406	1.34	181.67	0.29	0.12	621.70	1240.92	43.13
132	7.98	17.30	0.051	2.35	196.80	0.27	0.13	657.40	1312.18	13.48
133	-	-	-	-	-	-	-	-	-	-
134	7.97	-	-	2.95	-	-	-	-	-	5.79
141	-	-	-	-	-	-	-	-	-	-
142	7.57	32.10	0.066	1.23	241.68	0.30	0.10	860.10	1716.77	42.36
143	-	-	-	-	-	-	-	-	-	-
144	-	-	-	-	-	-	-	-	-	-
311	-	-	-	-	-	-	-	-	-	-
312	-	-	-	-	-	-	-	-	-	-
313	-	-	-	-	-	-	-	-	-	-
314	-	-	-	2.82	-	-	-	-	-	3.48
321	-	-	-	-	-	-	-	-	-	-
322	7.62	38.20	0.000	1.16	167.50	0.30	0.15	687.40	1372.06	43.07
323	7.91	-	-	2.38	216.27	0.26	0.20	644.50	1286.43	12.38
324	7.58	26.50	0.000	1.25	161.41	0.30	0.13	676.00	1349.30	42.34
331	7.52	60.70	0.000	1.41	190.07	0.29	0.10	722.60	1442.32	42.28
332	7.56	51.00	0.000	2.33	207.93	0.29	0.10	693.60	1384.43	42.38
333	-	-	-	-	-	-	-	-	-	-
334	7.51	80.90	0.132	1.92	249.10	0.28	0.09	817.20	1631.14	42.45
341	7.62	52.50	0.000	1.71	168.26	0.27	0.10	589.10	1175.85	43.20
342	-	-	-	-	-	-	-	-	-	-
343	7.81	52.50	0.081	1.80	179.91	0.27	0.17	639.30	1276.05	19.92
344	-	-	-	-	-	-	-	-	-	-

**APPENDIX DD: ORTHOPHOSPHATE CONCENTRATION ON 9 AUGUST 2006  
AT 0.72 L H<sup>-1</sup>**

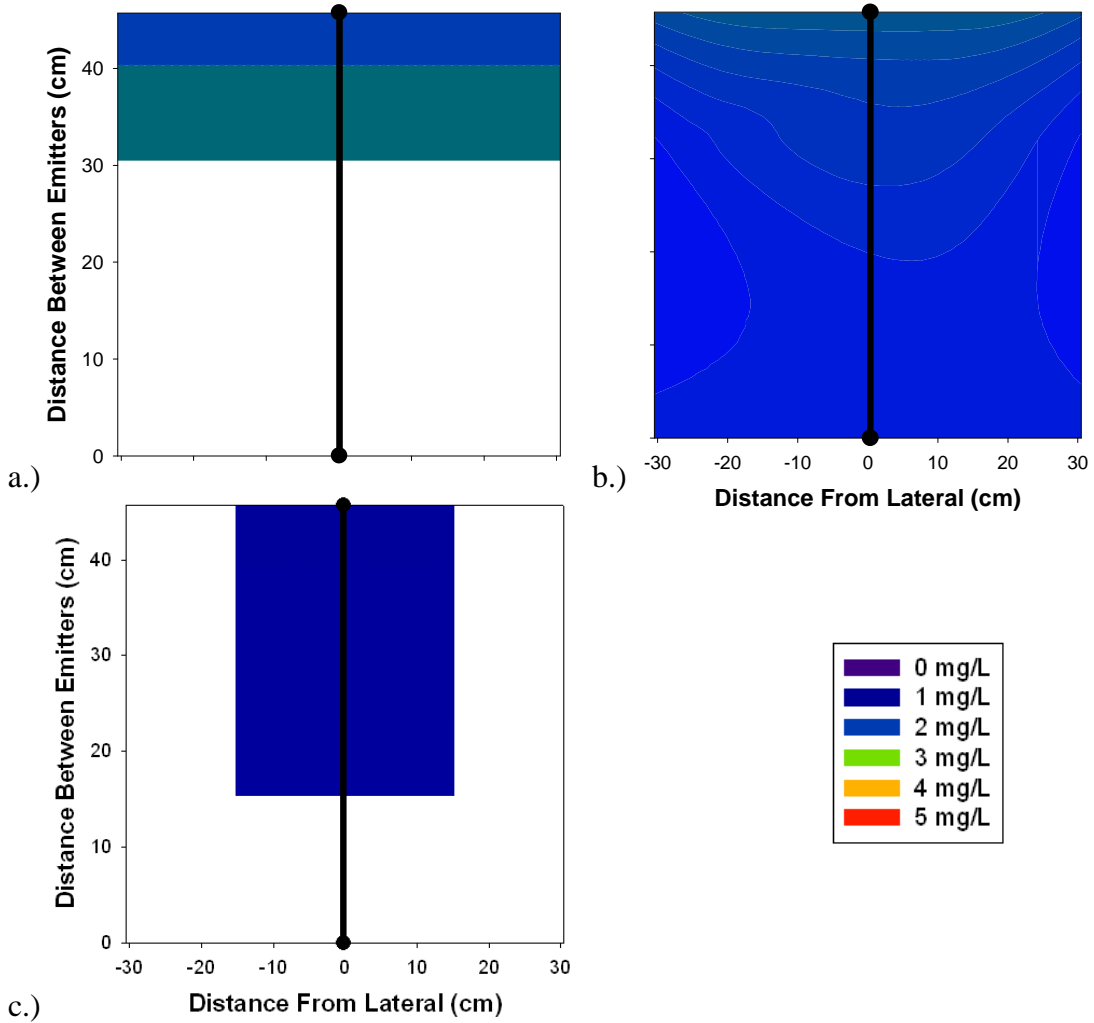

Orthophosphate concentration ( $\text{mgL}^{-1}$ ) on 9 August 2006 from  $0.72 \text{ L h}^{-1}$  emitter application rate at depths of a.) 15 cm, b.) 30 cm, and c.) 60 cm. No solution was obtained from lysimeters located at 45 cm depth. At 15 and 60 cm depth solution samples were obtained from limited lysimeters resulting in an incomplete graph. Black line located at zero distance from the lateral indicates location of lateral with respect to the x-axis.



**APPENDIX EE: ORTHOPHOSPHATE CONCENTRATION ON 9 AUGUST 2006  
AT 2.38 L H<sup>-1</sup>**

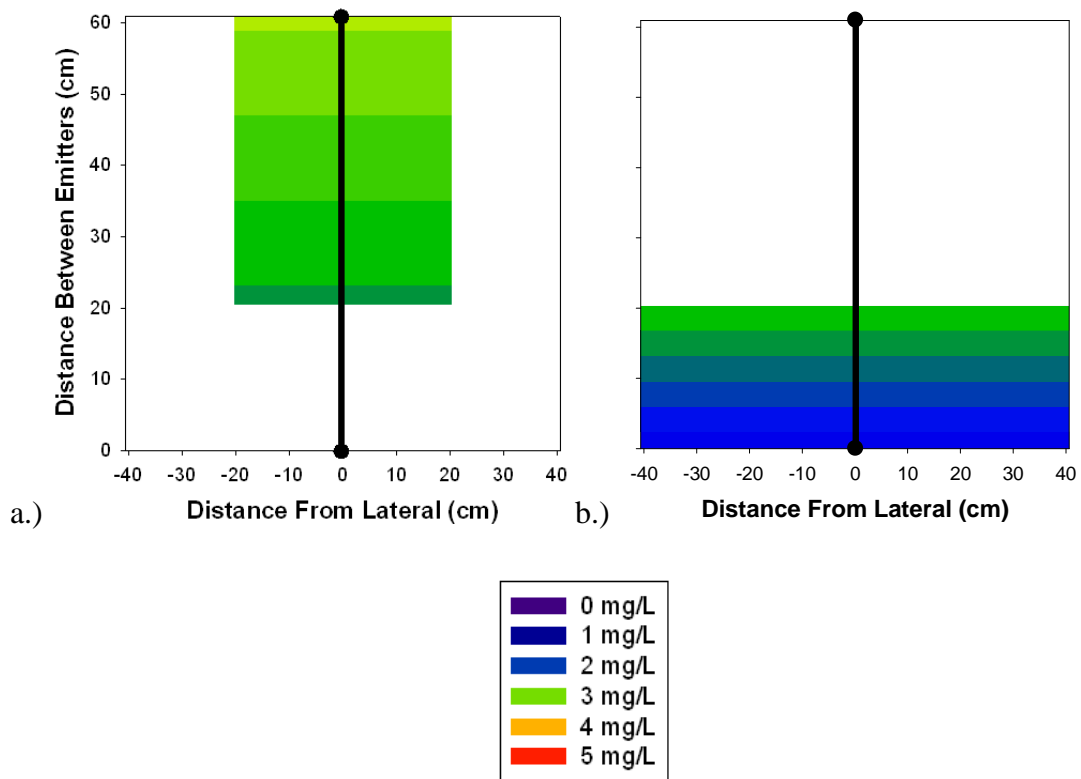

Orthophosphate concentration ( $\text{mgL}^{-1}$ ) on 9 August 2006 at  $2.38 \text{ L h}^{-1}$  emitter application rate at depths of a.) 15 cm and b.) 60 cm. No solution was obtained from lysimeters located at 30 and 45 cm depth. At 15 and 60 cm depth solution samples were obtained from limited lysimeters resulting in an incomplete graph. Black line located at zero distance from the lateral indicates location of lateral with respect to the x-axis.

**APPENDIX FF: CALCIUM CONCENTRATION ON 9 AUGUST 2006  
AT 0.72 L H<sup>-1</sup>**

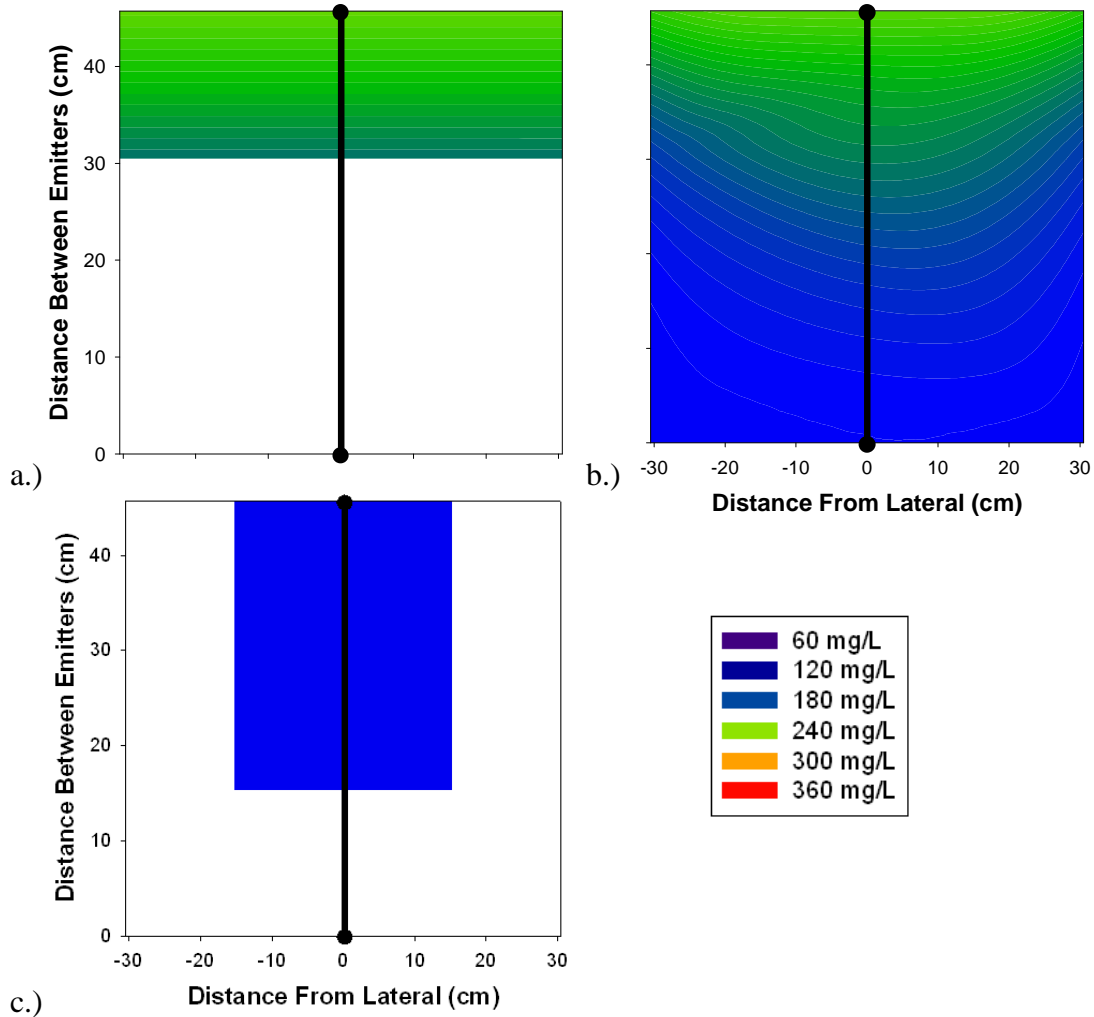

Calcium concentration ( $\text{mgL}^{-1}$ ) on 9 August 2006 from  $0.72 \text{ L h}^{-1}$  emitter application rate at depths of a.) 15 cm, b.) 30 cm, and c.) 60 cm. No solution was obtained from lysimeters located at 45 cm depth. At 15 and 60 cm depth solution samples were obtained from limited lysimeters resulting in an incomplete graph. Black line located at zero distance from the lateral indicates location of lateral with respect to the x-axis.

**APPENDIX GG: COPPER CONCENTRATION ON 9 AUGUST 2006  
AT 0.72 L H<sup>-1</sup>**

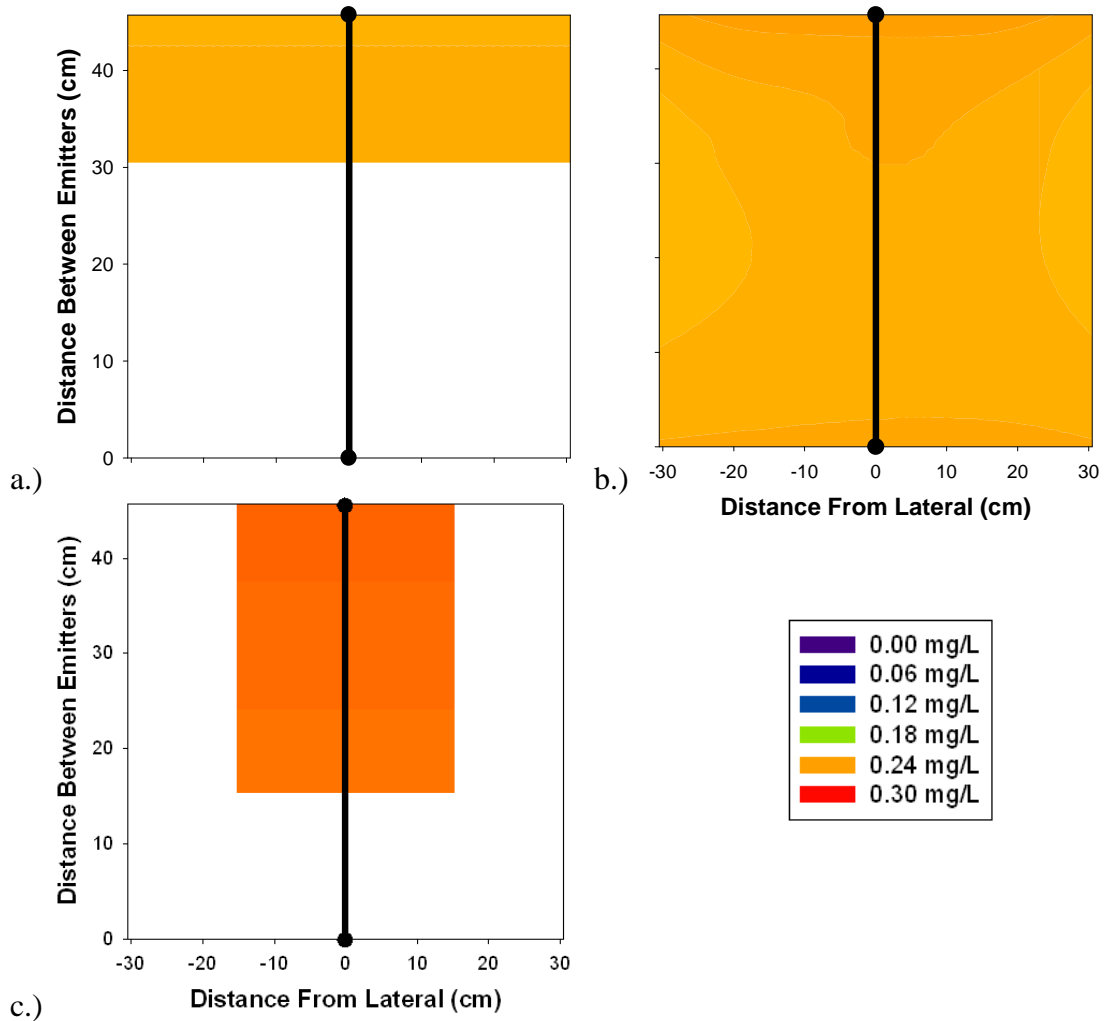

Copper concentration (mgL<sup>-1</sup>) on 9 August 2006 from 0.72 L h<sup>-1</sup> emitter application rate at depths of a.) 15 cm, b.) 30 cm, and c.) 60 cm. No solution was obtained from lysimeters located at 45 cm depth. At 15 and 60 cm depth solution samples were obtained from limited lysimeters resulting in an incomplete graph. Black line located at zero distance from the lateral indicates location of lateral with respect to the x-axis.

**APPENDIX HH: COPPER CONCENTRATION ON 9 AUGUST 2006  
AT 0.72 L H<sup>-1</sup>**

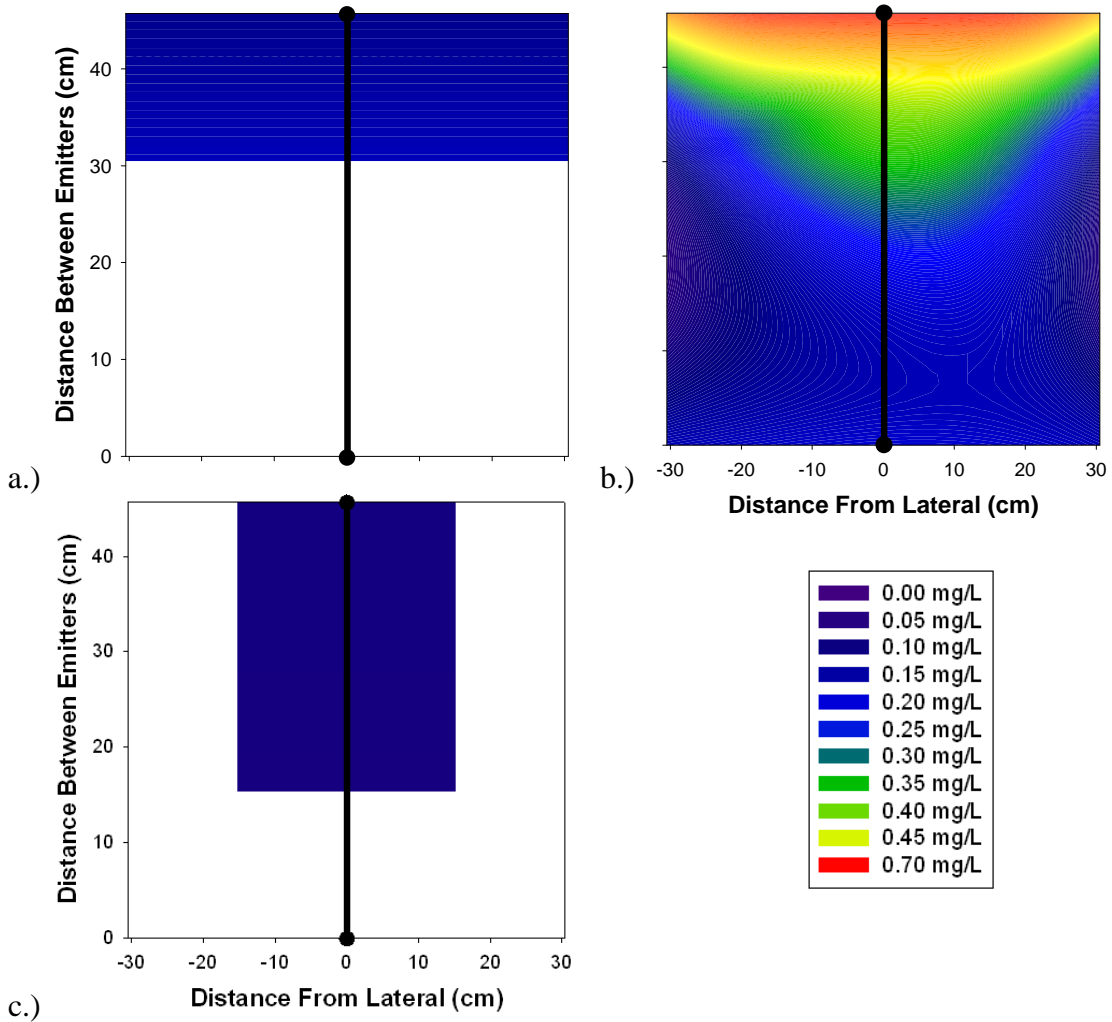

Zinc concentration ( $\text{mgL}^{-1}$ ) on 9 August 2007 from  $0.72 \text{ L h}^{-1}$  emitter application rate at depths of a.) 15 cm, b.) 30 cm, and c.) 60 cm. No solution was obtained from lysimeters located at 45 cm depth. At 15 and 60 cm depth solution samples were obtained from limited lysimeters resulting in an incomplete graph. Black line located at zero distance from the lateral indicates location of lateral with respect to the x-axis.

VITA

Lisa Michelle Fultz

Candidate for the Degree of

Master of Science

Thesis: NUTRIENT DISTRIBUTION FOLLOWING APPLICATION OF SWINE EFFLUENT THROUGH A SUBSURFACE DRIP IRRIGATION SYSTEM

Major Field: Plant and Soil Science

Biographical:

Personal Data: Born in Stillwater, Oklahoma, on October 17, 1981, daughter of Doug Fultz and Suzan Davis

Education:

Received Bachelor of Science degree in Environmental Sciences with emphasis in Natural Resources from Oklahoma State University, Stillwater, Oklahoma in December 2004.

Completed requirements for Masters of Science Degree in Plant and Soil Science from Oklahoma State University Stillwater, Oklahoma in May, 2009.

Experience:

May 2007 to Present: Research Specialist, Plant and Soil Science Department, Oklahoma State University; Responsibilities: conduct field and laboratory experiments under the direction of soil chemistry professor; supervising graduate and undergraduate students during laboratory procedures.

December 2004 to May 2007: Graduate Student, Plant and Soil Science Department, Oklahoma State University; Research focused on use of swine effluent as water and nutrient source through subsurface drip irrigation systems in semi-arid environments. Responsibilities: assisting with various projects in field and laboratory.

December 2004 to July 2005: Teaching Assistant, Fundamentals of Soil Science, Oklahoma State University; Responsibilities: lab preparation, instruction of labs and lectures, grading and developing assignments, and tutoring students.

Professional Memberships:

Soil Science Society of America; Soil and Water Conservation Society.

Name: Lisa Fultz

Date of Degree: May 2009

Institution: Oklahoma State University

Location: Stillwater, Oklahoma

Title of Study: NUTRIENT DISTRIBUTION FOLLOWING APPLICATION OF  
SWINE EFFLUENT THROUGH A SUBSURFACE DRIP  
IRRIGATION SYSTEM

Pages in Study: 105

Candidate for the Degree of Master of Science

Major Field: Plant and Soil Science

Scope and Method of Study: Concerns' regarding utilization of animal waste in agriculture has led to the use of systems such as subsurface irrigation to minimize contact between above ground biomass and the waste. However little is known about the movement and distribution of nutrients applied via subsurface irrigation systems. The purpose of this study is to determine the distribution of nutrients found in swine effluent when applied through a subsurface drip irrigation system located on the Panhandle Research Station in Goodwell, Oklahoma. Suction lysimeters were used to collect solution samples at and between emitters on the inlet and distal ends of a single irrigation tape. Solution samples were obtained from fields with application rates of  $2.38 \text{ L h}^{-1}$  (0.63 gph) and  $0.72 \text{ L h}^{-1}$  (0.19 gph) respectively. Soil solution samples taken prior to swine effluent application were used to determine background levels of measured nutrients from previous effluent applications. Solution samples drawn within one day following each effluent application were used to determine the distribution and movement of nutrients. pH values, electric conductivity, orthophosphates, nitrate-N, ammonia-N, copper, zinc, and calcium was preformed on each sample.

Findings and Conclusions: Calcium and copper concentrations increased over time regardless of application rate. Increased application rates ( $2.38 \text{ L h}^{-1}$ ) resulted in increased  $\text{NO}_3^-$ -N laterally with regards to the irrigation tape. Orthophosphate concentrations decreased with depth indicating no downward movement regardless of application rate. Emitter application rates of  $0.72 \text{ L h}^{-1}$  resulted in no significant correlation between lysimeter location and nutrient concentration, with the exception of orthophosphate. Based on the results of this study it appears that nutrients are not being lost. At the  $2.38 \text{ L h}^{-1}$  emitter application rates  $\text{NO}_3^-$ -N and OP concentrations near the surface place these nutrients directly in the rooting zone for the plants. `

ADVISER'S APPROVAL: Dr. Jeffory Hattey

---