

INVESTIGATION ON THE CHATTER VIBRATION  
AND SURFACE TEXTURE IN VIBRATION ASSISTED  
MICRO-MILLING PROCESS

By  
ANJU POUDEL

Bachelor of Science in Mechanical Engineering  
University of New Orleans  
New Orleans, Louisiana  
2013

Submitted to the Faculty of the  
Graduate College of the  
Oklahoma State University  
in partial fulfillment of  
the requirements for  
the Degree of  
MASTER OF SCIENCE  
July, 2015

INVESTIGATION ON THE CHATTER VIBRATION  
AND SURFACE TEXTURE IN VIBRATION ASSISTED  
MICRO-MILLING PROCESS

Thesis Approved:

Dr. Xiaoliang Jin

---

Thesis Adviser

Dr. Kaan A. Kalkan

---

Dr. Matthew J. Klopstein

---

## ACKNOWLEDGEMENTS

I would like to express my sincere gratitude and appreciation to my supervisor Dr. Xiaoliang Jin for his invaluable inspiration and motivation throughout my research. Dr. Jin have always been a great mentor and have inspired me through enthusiasm and welcoming nature. I truly appreciate his advice, encouragement and support without which this thesis would not have been possible.

I would like to thank Dr. Kaan Kalkan and Dr. Matthew Klopstein for serving in my thesis committee and providing valuable suggestions for improvement.

I would like to thank Dr. Sandip Harimkar and Tanaji Paul for their invaluable time and help on measuring the surface profile using the nanovea profilometer.

I greatly value my colleagues Arjun, Boyuan and Gopal in Precision Manufacturing Processes Lab for their friendship and help during my research.

I would like to express my heartfelt gratitude to my parents for their unconditional love and support throughout my studies. I would like to thank my siblings for enduring me all these years and supporting my choice to continue my studies.

I would like to thank all my friends and family here and back in Nepal for their immense love and support during my graduate studies.

Name: ANJU POUDEL

Date of Degree: JULY, 2015

Title of Study: INVESTIGATION ON THE CHATTER VIBRATION AND SURFACE TEXTURE IN VIBRATION ASSISTED MICRO-MILLING PROCESS

Major Field: MECHANICAL AND AEROSPACE ENGINEERING

Abstract:

Regenerative chatter is an unstable form of self-excited vibration in the machining process. It is one of the main obstacles which limit the productivity and the surface quality. This thesis investigates the effect of vibration assistance on high frequency regenerative chatter in the micro milling process. External vibration is applied on the Al-6061 workpiece in a range of frequencies and amplitudes using the piezoelectric actuators. The chatter vibration is monitored using the sound pressure signal measured by a microphone. The chatter with vibration assistance in 1-D (feed or normal direction) and 2-D is studied. The effect of the frequency and amplitude of the vibration assistance on chatter is analyzed. It is concluded from the experimental study that the vibration assistance is able to effectively attenuate the high frequency chatter in the micro milling process.

Surface texturing is an innovative technique to generate patterns on the surface. These surfaces can be used for friction reduction in several applications such as internal combustion engines, micro-electrical- mechanical systems (MEMS), micro-fluids etc. Electric discharge texturing, laser texturing and photolithography are some of the finishing processes applied to the machined surface to create surface textures. However, this requires a long process which makes it costly and time consuming. This thesis focuses on surface texture generation by micro side milling with vibration assistance. External vibration is applied on the workpiece at the frequency and input voltage which can generate micron level amplitude. The machined surface profile is measured using a 3-D profilometer. Surface textures created with and without vibration assistance is compared. The effect of feed rate and different types of tools on surface texture is also studied.

Keywords: Regenerative chatter, vibration assistance, micro milling, surface texturing

## TABLE OF CONTENTS

CHAPTER 1 .....	1
INTRODUCTION.....	1
1.1 Background .....	1
1.2 Objective of the Study .....	5
1.3 Organization of the Thesis .....	6
CHAPTER 2 .....	8
LITERATURE REVIEW.....	8
2.1 Vibration Assisted Machining.....	8
2.2 Self-Excited Vibration: Regenerative Chatter Mechanism in Milling.....	10
2.2.1 Chatter Prediction Techniques .....	13
2.2.2 Chatter Suppression Techniques.....	14
2.2.3 Vibration Assisted Machining for Chatter Stability .....	20
2.2.4 Surface Texturing using Vibration Assistance .....	21
2.4 Summary .....	23
CHAPTER 3 .....	25
ATTENUATION OF REGENERATIVE CHATTER IN VIBRATION ASSISTED MILLING.....	25
3.1 Overview .....	25
3.2 Experimental Setup .....	25
3.2.1 Prediction of Chatter Stability Lobe .....	26
3.2.2 Chatter stability of micro milling.....	29
3.3 Experimental Procedures.....	31
3.4 Experimental Results.....	32
3.4.1 Chatter Amplitude in 1-D Vibration Assisted Milling.....	34
3.3.1 Chatter Amplitude in 2-D Vibration Assisted Milling .....	40

3.4 Chatter Amplitude with Feed Rate .....	42
3.5 Analysis and Discussion of Vibration Assistance on Chatter Amplitude .....	44
CHAPTER 4 .....	48
GENERATION OF SURFACE TEXTURE IN VIBRATION ASSISTED MILLING...	48
4.1 Overview .....	48
4.2 Experimental Setup and Procedures .....	48
4.3 Experimental Results.....	51
4.3.1 Surface texture in conventional and vibration assisted milling .....	51
4.3.2 Surface Texture with feed rate in vibration assisted milling .....	53
4.4 Analysis and Discussion of Vibration Assistance on Surface Texturing .....	55
CHAPTER 5 .....	56
CONCLUSIONS AND RECOMMENDATIONS .....	56
5.1 Conclusion.....	56
5.2 Recommendations for future work.....	58
REFERENCES .....	59
APPENDIX A.....	65
TIME DOMAIN SIMULATION FOR THE TOOL TIP TRAJECTORIES WITH EACH ROTATION OF THE TOOL .....	65

## LIST OF TABLES

Table 3.1 Aluminum 6061 Composition .....	29
Table 3.2 Cutting Parameters in CM and VAM .....	32
Table 3.3 Cutting parameters in 1D VAM.....	34
Table 3.4 Cutting Parameters in 2D VAM .....	38
Table 3.5 Cutting parameters .....	43
Table 4.1 Cutting parameters .....	51

## LIST OF FIGURES

Figure 1.1 Surface texturing in different applications [2].....	2
Figure 1.2 Schematics of vibration assisted orthogonal cutting processes.....	4
Figure 1.3 Vibration assisted milling process.....	5
Figure 1.4 Tool tip trajectories (a) without vibration (b) with vibration [13].....	5
Figure 2.1 Regenerative of waviness in a milling model with two degrees of freedom [36] .....	11
Figure 2.2 Effect of phase of subsequent tooth passing on chip thickness.....	12
Figure 3.1 Schematic for impact hammer test .....	26
Figure 3.2 FRFs in feed and normal directions at the tool tip .....	27
Figure 3.3 Stability lobe diagram.....	28
Figure 3.4 Experimental setup .....	29
Figure 3.5 Schematic of the experimental system .....	30
Figure 3.6 2D Vibration assisted stage .....	31
Figure 3.7 Frequency domain signal for air cutting.....	33
Figure 3.8 Frequency domain signal for milling without vibration assistance.....	33
Figure 3.9 Frequency domain signal for vibration assisted milling.....	34
Figure 3.10 Chatter amplitude in feed direction .....	35
Figure 3.11 Chatter amplitude in normal direction.....	36
Figure 3.12 Chatter amplitude in feed direction (repeated) .....	37
Figure 3.13 Chatter amplitude in normal direction (repeated) .....	37
Figure 3.14 Chatter amplitude with vibration assistance at 9 kHz .....	38
Figure 3.15 Chatter amplitude with vibration assistance at 8 kHz .....	39
Figure 3.16 Chatter amplitude with vibration assistance at 7 kHz .....	39
Figure 3.17 Chatter amplitude with vibration assistance at 5 kHz .....	40
Figure 3.18 Chatter amplitude with 2-D vibration assistance at 9 kHz .....	41
Figure 3.19 Chatter amplitude with 2-D vibration assistance 8 kHz .....	41



Figure 3.20 Chatter amplitude with 2-D vibration assistance at 7 kHz .....	42
Figure 3.21 Chatter amplitude with 2-D vibration assistance at 5 kHz .....	42
Figure 3.22 Chatter amplitude in conventional and vibration assisted milling .....	43
Figure 3.23 Schematic of chip formation in (a) CM and (b) VAM.....	44
Figure 3.24 Relative cutting tool's trajectory in two consecutive tooth passing periods in VAM.....	46
Figure 4.1 Tool tip trajectory using time domain simulation for (a) conventional (b) vibration assisted milling .....	50
Figure 4.2 Schematic of the area selected for surface measurement using nanovea and contact profilometer .....	50
Figure 4.3 Surface texture in (a) conventional (b) vibration cutting with carbide tool. ...	52
Figure 4.4 Surface texture in (a) conventional (b) vibration cutting with diamond tool ..	52
Figure 4.5 Surface texture and profiles at (a)(d) 30 $\mu\text{m}/\text{flute}$ , (b)(e) 50 $\mu\text{m}/\text{flute}$ (c)(f) 100 $\mu\text{m}/\text{flute}$ using carbide tool .....	53
Figure 4.6 Surface texture and profiles at (a)(d) 30 $\mu\text{m}/\text{flute}$ , (b)(e) 50 $\mu\text{m}/\text{flute}$ (c)(f) 100 $\mu\text{m}/\text{flute}$ using diamond tool.....	54

## NOMENCLATURE

CM= Conventional machining

VAM= Vibration assisted machining

$m_x, m_y$ = Mass in X and Y directions

$k_x, k_y$ = Stiffness in X and y direction

$x_t, y_t$ = Vibration of cutting tool in X and Y directions

$x_w, y_w$ = Vibration of workpiece in X and Y directions

$F_x, F_y$ = Dynamic cutting forces in X and Y directions

$h_d$ = Overall dynamic chip thickness

$h_s$ = Static chip thickness

$h_t$ = Dynamic chip thickness due to tool's vibration

$h_w$ = Dynamic chip thickness due to vibration assistance

$\phi_j$ = Tool's immersion angle

$T$  = Tooth passing period

$X, Y$  = Vibration amplitude of workpiece in x and y directions

$\phi_x, \phi_y$ = Vibration phase of workpiece in X and Y directions

$\omega$  = Vibration frequency of workpiece

$c_s, c_p$ = Structural and process damping coefficients

$\omega_c$ = Chatter frequency

$k$ = Number of complete wave marks on the surface during each tooth period

$\varepsilon$ = Phase shift in radians

$\omega_s$ = Spindle frequency

$\omega_T$ = Tooth passing frequency

# CHAPTER 1

## INTRODUCTION

### 1.1 Background

Micro-milling is a fabrication technique used for manufacturing small components with complex geometries. These types of components are universally used in biomedical, automotive, aerospace, and shipping industries which needs an accuracy of micron level. These materials should be designed to achieve the maximum production and low cost features which can be obtained by increasing the material removal rate. However, regenerative chatter vibration limits these features in micro-milling process. Chatter not only limits the productivity of metal cutting process but also results in poor surface quality, reduced accuracy, excessive noise and machine tool damage [1]. Therefore, the need to reduce chatter has been increased for higher productivity and precision and lower production cost. Furthermore, surface texturing has been another topic of research due to the need of friction reduction in several applications such as internal combustion engines and micro-electrical-mechanical systems (MEMS) [2]. Surface texturing enhances the tribological performances which in turn increases the overall performance of a product. The major applications of surface texture in several mechanical systems especially in MEMS is shown in Figure 1.1.

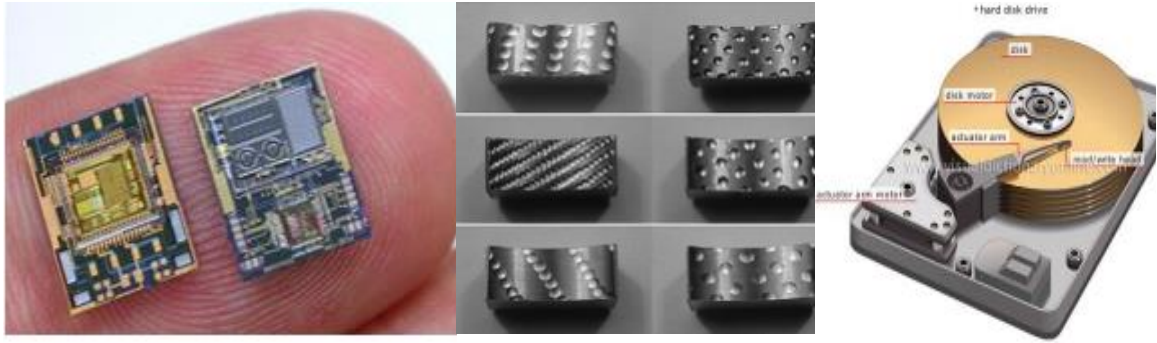

Figure 1.1 Surface texturing in different applications [2]

Regenerative chatter is a self-excited vibration which causes poor surface quality, and inaccuracy in the machining process. The presence of such vibration reduces the efficiency and overall productivity. Therefore, extensive research have been conducted to suppress or attenuate chatter in machining. Numerical and experimental solutions were developed in the past to reduce chatter in the machining process. The chatter suppression techniques are classified into two main categories: passive and active chatter suppression. The passive technique is designed to suppress chatter by using additional devices such as dampers or by improving the machine tool design [3-6]. This technique is inexpensive and easy to implement. However, it requires very accurate tuning for desired performance which is difficult due to uncertainties in the machine-tool structure and the cutting process. Active techniques continuously monitor the dynamic state of the machine tool system, diagnose chatter and make decisions to suppress chatter. Active chatter suppression was successfully applied in varying process parameters such as feed rates and spindle speeds [7], rake angle and clearance angle [8], and monitoring the force signal [9]. However, the implementation of active control is costly because the system requires more complex hardware and software. Furthermore, the chatter frequencies dealt with in the active chatter suppression in the literatures are all below 1000 Hz due to the limitation of controller

bandwidth. However, in micro-milling process, chatter occurs at higher frequency in the range of 4,000 – 10,000 Hz compared to conventional milling due to reduced size of the cutting tool [10]. At such high chatter frequency it is difficult to implement active control technique hence it generates new challenges in developing effective strategy for chatter suppression.

Surface texturing is a process of creating patterns on the surface. The proper pattern on structured surface can improve the mechanical, thermal and viscous properties. The structured surface can be utilized in friction reduction, heat exchange, superhydrophobic surfaces and optical gratings [11]. The desired surface textures have been generated in the past using vibration assisted machining by changing the vibration parameters, cutting parameters, and tool geometry in turning processes. However, surface texturing in micro-milling process have not been investigated before which is covered in this thesis.

This thesis focuses on the effect of vibration assistance on chatter vibration and surface texture generation in the micro-milling process. Vibration assisted machining (VAM) is a technique performed by applying an external vibration at high frequency and small amplitude to create relative displacement between the tool and the workpiece in addition to the original cutting motion. There are two types of vibration assistance methods in orthogonal cutting: 1D and 2D vibration assistance as shown in Figure 1.2. 1D VAM drives the tool harmonically in a linear path which is overlapped on the cutting direction of the workpiece. While 2D VAM adds a vertical motion to the horizontal motion of 1D VAM. This causes the tool tip to move in a small circle or an ellipse which is overlapped on the cutting motion of the workpiece. Application of vibration assisted cutting offers several advantages in the turning processes for a variety of materials such as aluminum,

hardened steel, Inconel and glass: tool life extension, reduced instantaneous chip load, and improved surface quality [12].

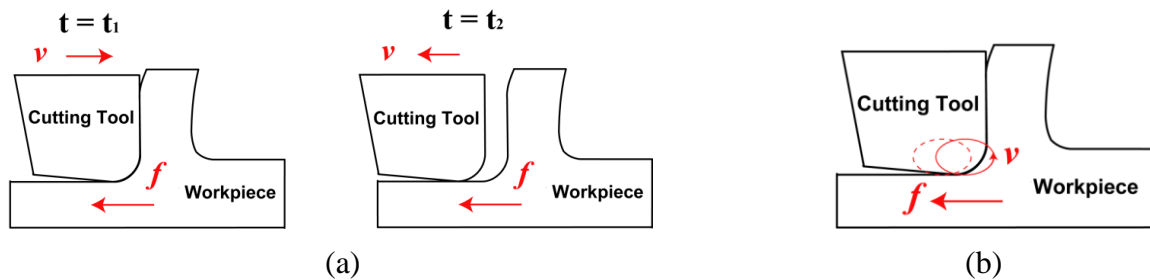

Figure 1.2 Schematics of vibration assisted orthogonal cutting processes  
vibration assisted orthogonal cutting in (a) 1D (b) 2D

Vibration assistance has been applied in micro-milling processes within the past ten years [12]. Figure 1.3 shows the schematic of vibration assisted milling process by exciting the workpiece using the piezo-actuators. In milling process, material is removed when the tool tip interacts with the workpiece. The applied vibration significantly modifies the relative trajectory between the tool and the workpiece therefore changes the material removal mechanism. Figure 1.4 shows the tool edge trajectories in two consecutive tooth passing period. In conventional milling (CM) process the closed area is formed when the cutting edge contacts with the workpiece material all the time as shown in Figure 1.4 (a). When vibration is applied, it breaks the closed area in CM and helps in chip flow as shown in Figure 1.4 (b). Adding vibration assistance modifies the dynamic chip thickness, therefore influences the cutting dynamics as well as the surface generation. Previous studies demonstrated that properly added vibration is able to reduce the cutting force, decrease tool wear rate, minimize the burr formation, and reduce surface roughness [12]. However, the effect of vibration on the chatter stability and surface texturing which significantly influence the efficiency and quality in micro-milling was not investigated.

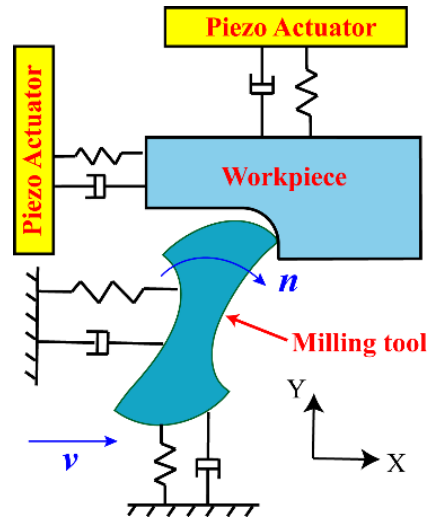

Figure 1.3 Vibration assisted milling process

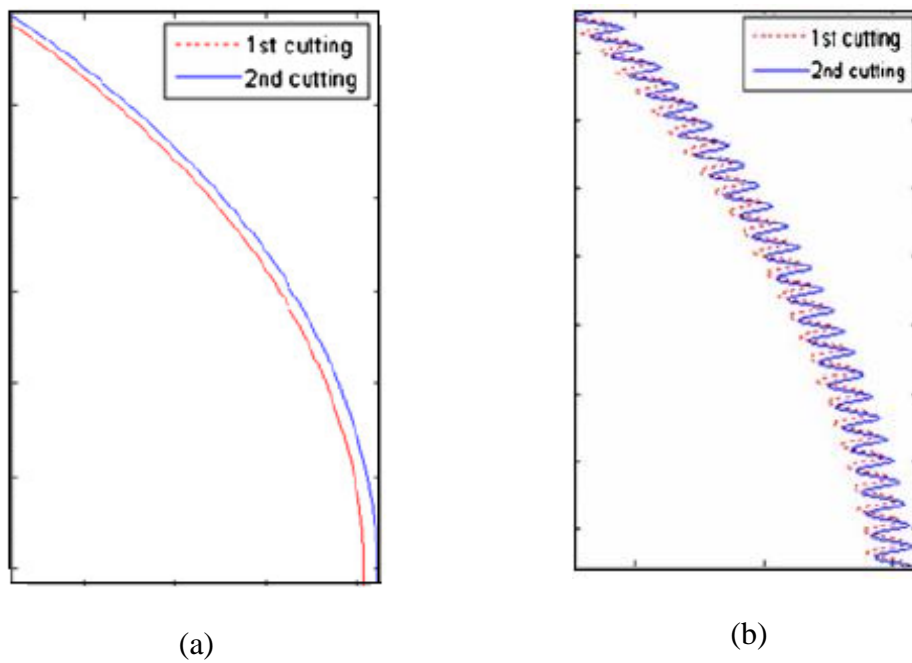

Figure 1.4 Tool tip trajectories (a) without vibration (b) with vibration [13]

## 1.2 Objective of the Study

Based on the previous research results, this thesis is formulated with the purpose of clarifying the following two hypotheses:

(1) The vibration assistance is able to reduce the chatter vibration with the frequency in the range of 3000 – 5000 Hz, which is typical in micro milling, yet is difficult to attenuate using conventional active damping strategy.

(2) Providing vibration assistance is able to generate the surface texture with various geometric characteristics, depending on the cutting and vibration parameters with vibration assistance in 2-D direction.

The objective of this study is to investigate the effects of assisted vibration parameters on the chatter vibration and surface texturing during the 2-D vibration assisted micro milling processes. The outcome of this research is to provide optimum cutting and vibration parameters in order to improve the machining efficiency and surface quality.

In this thesis, a vibration stage driven by the piezoelectric actuator is developed to provide high frequency vibration assistance on the workpiece in the feed and normal directions. The experiments are performed by applying external vibrations in 1-D and 2-D with a series of amplitudes and frequencies. The chatter amplitude between conventional micro milling (CM) and VAM are compared and analyzed for the study of chatter stability. Also, the effect of vibration assistance, change in feed rate and tool geometries in surface generation is investigated here.

### **1.3 Organization of the Thesis**

This thesis consists of five chapters which is organized as follows: Following this chapter, a detailed review of the literature with an analytical and experimental works on vibration assisted machining, chatter stability and surface texturing is presented. It includes a review on the strategies applied to predict, reduce, and suppress chatter in milling process. The techniques applied in the surface texture generation through vibration assisted



machining is also presented. Chapter 3 presents methodologies which includes experimental setup and procedures to perform the chatter tests with vibration assistance. The experimental results from the chatter test along with result analysis and discussion is also presented. Chapter 4 presents the experimental setup, procedures, results, result analysis and discussion on surface texturing using vibration assistance. Finally, chapter 5 presents the conclusion of the current work and recommendations for future research.

## **CHAPTER 2**

### **LITERATURE REVIEW**

This chapter is an overview of vibration assisted machining, regenerative chatter suppression and surface texturing. Previous studies on vibration assisted machining and the effects of vibration assistance on the cutting force, surface roughness and tool life are discussed. The regenerative mechanism in machining process is introduced, and the strategy of reducing and suppressing chatter vibration in the literature is described. The surface texture generation with the application of vibration assisted machining technology is described.

#### **2.1 Vibration Assisted Machining**

VAM is performed by applying high frequency and small amplitude to create a displacement between the tool and the workpiece. Due to the presence of simple cutting geometry and dynamics in turning as compared to milling, most of the research on VAM were focused in turning. Many researchers found that VAM has numerous advantages over conventional machining (CM). VAM was extensively used in order to machine ferrous, hard and brittle metal using diamond and carbide tools. It resulted in longer tool life [14-16], improved surface finish, burr suppression[17], and greater depth of cut for ductile regime machining of brittle materials[18] as compared to CM.

Ultrasonic elliptical vibration machining (UEVM) was first introduced in 1994 by Shamoto and Moriwaki [19]. This technique have been a promising cutting method in terms of all cutting performances and is extensively used since a decade[17]. UEVM was used in several difficult to cut materials such as hardened steel [20], glass [18], and sintered WC [21]. UEVM resulted in smaller cutting force and longer tool life as compared to CM[20]. It was shown that ultrasonic vibration assisted machining have a huge advantage over normal VAM and CM.

Numerous research works were focused on the study of the effect of cutting and vibration parameters on machining process. The cutting force was reduced in VAM due to reduced friction between the tool and the workpiece [22, 23] and the separating characteristics of the tool and workpiece [17, 24]. In the previous studies, it was shown that vibration cutting gives a better result in the low cutting speed [17, 23, 24], and at high vibration frequency and amplitude [25, 26]. It was also found that the cutting force in an ultrasonic vibration cutting method is solely dependent upon the cutting speed, vibration frequency and an amplitude [14, 27, 28].

Besides turning, VAM was also used in micro-milling process to improve the cutting performance which reduced the tool wear and improved the surface quality [29]. A two-dimensional vibration assisted micro-end milling was employed to machine the hardened steel and study the effects of vibration parameters on surface roughness and tool wear[30]. A similar work was performed in an aluminum alloy by applying an ultrasonic vibration in the micro end milling operation where vibration in feed direction resulted in reduced cutting force and uniform small chips [13]. Through the experimental results, it was concluded that the surface of the slot bottom was worse and the slot width was better

when ultrasonic vibration was applied in the feed direction. The vibration assisted milling works in the past were mainly focused to investigate the effect of vibration on the cutting force [13, 31, 32], tool wear [30, 33, 34], surface roughness [30, 32, 34, 35] and tool life. However, the study on chatter stability and surface texturing in vibration assisted milling is yet to be done. This paper presents the study of the effect of vibration assistance on chatter amplitude and surface texturing in micro-milling process.

## **2.2 Self-Excited Vibration: Regenerative Chatter Mechanism in Milling**

Chatter vibration is caused due to an interaction between the cutting tool and the workpiece. It gradually grows during machining which causes instability in the system. Chatter can be divided into primary and secondary categories [36]. Primary chatter is caused by the friction between the tool and the workpiece, thermomechanical effects on the chip formation and mode coupling while secondary chatter is caused by the regeneration of waviness of the workpiece surface [1]. Chatter can occur due to several reasons such as tool geometry, machine tool design and material properties. Chatter theory was first introduced by Tobias and Fishwick [37] and Tlustý and Poláček [38]. It was documented that the primary cause of chatter under most machining conditions is a regenerative effect.

The mechanism by which vibration occurs can distinguish frictional, mode and regenerative chatter. Frictional chatter is caused when rubbing on the clearance face excites the vibration in the tangential force direction and limits in the radial force direction. Mode coupling chatter occurs when the vibration in the radial force direction generates vibration in the tangential force direction and vice versa. This causes simultaneous vibration in the tangential and radial force directions. The source for their cause could be due to friction on

the rake and clearance surface, chip thickness variation, shear angle oscillations and the regeneration effect [1].

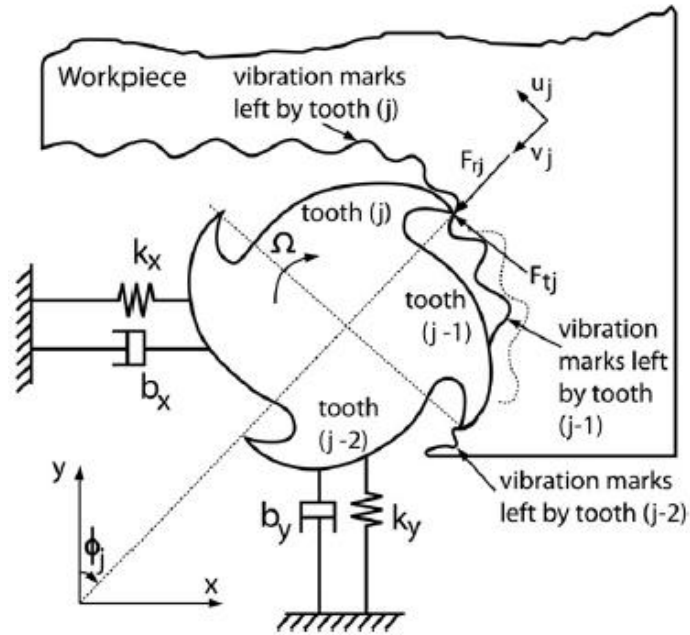

Figure 2.1 Regenerative of waviness in a milling model with two degrees of freedom [36]

Regenerative chatter is the most common form of self-excited vibration. During machining the cuts overlaps which act as a source of vibration amplification and causes regenerative chatter. In milling, the next tooth in cut attacks the wavy surface left by the cutter vibration and generates a new wavy surface as shown in Figure 2.1. The phase difference between the waves left by previous teeth and the current one causes chip thickness and cutting tool force to vary [1]. This process causes the vibration to amplify which results in instability.

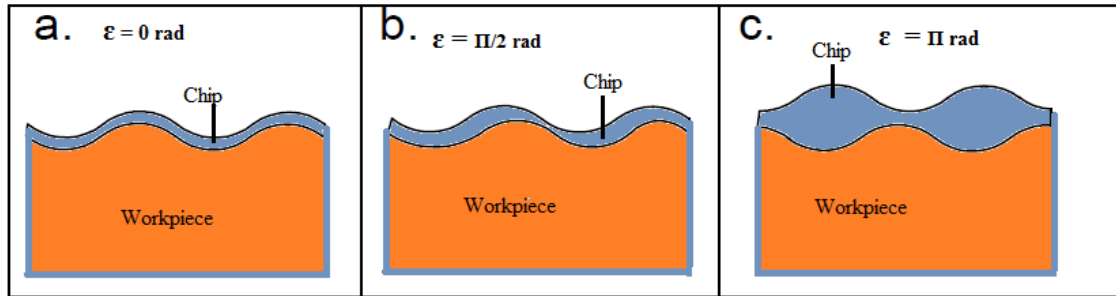

Figure 2.2 Effect of phase of subsequent tooth passing on chip thickness

The phase shift,  $\varepsilon$  in radians, can be calculated as a function of tooth period,  $T$ , and chatter frequency,  $\omega_c$

$$2\pi k + \varepsilon = T\omega_c$$

where  $k$  is the number of complete wave marks on the surface during each tooth period. In milling, the combination of waviness on the surface left by the previous tooth and vibration of the currently cutting tooth create periodically changing chip thickness. Figure 2.2 shows the variation in chip thickness depending on the phase shift between the undulations of successive tooth paths. Figure 2.2 a. shows that a constant chip thickness is produced despite any disturbance in the system when the phase shift is zero. However, Figure 2.2.b and Figure 2.2 c shows the varying chip load with a phase shift  $\pi/2$  and  $\pi$  where both of them results in an unstable conditions. The oscillating chip thickness causes varying forces which adds more vibration into the system and make the system unstable [39]. Therefore, the most stable condition, in case of regenerative effect is obtained when the phase shift is zero. Zero phase shift is obtained when the tooth passing frequency is an integer fraction of the chatter frequency.as:

$$\omega = \frac{60k \omega_c}{2\pi}, k = 1,2,3 \dots$$

where  $\omega$  represents the spindle speed (rpm).

### **2.2.1 Chatter Prediction Techniques**

During machining, instability is caused due to the development of regenerative chatter vibration [37, 40]. Mostly, the stability is predicted by using a stability lobe diagram which reflects the relation between critical limit of depth of cut and the spindle speed. In order to determine the stability lobe diagram, it is important to know the machine tool dynamics at the tip of the tool which comes in contact with the workpiece during cutting. The stability lobe diagram can be used for stable cutting by choosing the stable zone and make the most of the lobbing effect. However, choosing the stable zone only is not possible due to the need of high material removal rate. Therefore, it is important to change the system behavior and modify the stability frontier to get a stable cutting. Numerous analytical and experimental works were performed in milling process to improve the accuracy in predicting the stability. Some of the analytical models were based on the tool geometry and dynamic system of machine-tool. The analytical chatter stability prediction models are difficult to implement due to the complexity and requirement of deep knowledge in machining process. Also, it is difficult to ensure the stable cutting by predicting the status of chatter stability during machining and scheduling the correct cutting parameters. Therefore, an experimental methods are developed to detect chatter. These days, chatter during machining is detected through vibration, sound and power signal sensors. When the sensors are used, identification of chatter stability lobe diagram is not required. The experimental chatter prediction models are comparatively simpler and contains less inaccuracies than analytical models. However, experimental models are limited to the tool, spindle, tool holder and the material.

In this thesis, a microphone sensor is used to detect the chatter because of its excellent sensing capacity as compared to other sensors [40]

## **2.2.2 Chatter Suppression Techniques**

Chatter suppression is a way to control chatter and prevent the negative effects that can be caused by chatter vibrations. Mostly, stability lobe diagrams are used in chatter detection. Only stable region is machined to avoid chatter. However, machining only the stable region reduces the material removal rate and overall productivity. Therefore, better chatter suppression techniques are required to handle the pressure of high productivity and high precision in the manufacturing industries. The chatter suppression techniques are classified into two main categories: passive chatter suppression and active chatter suppression. The passive suppression techniques are designed to suppress chatter by changing the system behavior which can be done either by using an additional devices such as dampers or by improving the machine tool design. While active element is similar to the passive but can continuously monitor the dynamic state of the machine tool system, diagnose chatter and make decisions to suppress chatter.

### **2.2.2.1 Passive Chatter Suppression**

In passive chatter suppression technique, the system behavior was changed by adding additional devices such as mechanical damper[41], impact damper[42], and dynamic vibration absorber[43]. In this technique, other way for stable cutting was by improving the machine tool design [44] and using a non-standard cutting tool [45]. Passive elements used in chatter suppression are easy to implement and inexpensive as compared



to active elements. Passive devices can absorb extra energy, damp, reduce and control the regenerative chatter effect.

## **1. Change in Machine Tool Design**

Chatter can be suppressed by changing the machine tool design. Wang and Lee [44] proposed a chatter suppression technique by redesigning the spindle of the structure, which was found to be the weakest component through several cutting tests and an analysis of the process vibration. Marui et al. [46] proposed a system by inserting a friction plate within the overhang shank of the cutting tool system. This in turn increased the damping capacity of the system by improving the friction acting between the inner wall of a rectangular hole made at the overhanging shank of the cutting tool system and the surface of the plate.

Yusoff et. al [45] evaluated the performance of process damped milling considering the tool geometries experimentally. An effect of edge radius, rake and relief angles and variable helix/pitch on damping performance was studied. It was found that the damping performance is significantly increased with variable helix/pitch angles, moderately improved with increased cutting edge radius and have small effect with the change in rake and relief angles. De Lacalle and Mentxaka [47] changed the system behavior by reducing the tool shank. Also, the stable critical depth of cut was increased and suppressed chatter by using non-standard cutting tools with variable pitch and helix angle [48, 49].

## **2. Use of Passive Elements**

The additional devices such as dampers and absorbers have lower rigidity and are able to damp and reduce chatter. Xiao et. al [27] purposed a method to suppress chatter vibration in turning by applying external vibration. The vibration cutting was found to

suppress the regenerative chatter effectively irrespective to the tool geometry. Vibration cutting was found to achieve higher stability as compared to conventional cutting. Similarly, a theoretical and an experimental study was done on chatter suppression by adding an ultrasonic elliptical vibration on the cutting tool [50]. Here, vibration was applied in two directions and it was shown that the machining accuracy was improved. The regenerative chatter suppression for high chip removal was presented by considering bending mode of vibration where the result was discussed on the well-known stability lobe diagram [51]. Their theoretical model on an effect of ultrasonic vibration on chatter was also validated experimentally. A chatter control system on the basis of harmonic excitation of a workpiece for orthogonal cutting was presented by Yao et al. [52]. It was shown that the parametric excitation with an appropriate frequency and large amplitude have a chatter suppression effect disregard of waveform.

Miguélez et. al [43] modeled the improved design for chatter stability using a dynamic vibration absorber in boring operations. Semercigil and Chen [42] suggested to reduce the excessive vibration of the end-mill cutter by using an impact damper. The effectiveness of an impact damper in controlling the excessive oscillations of a long end milling cutter was presented numerically. The chatter energy was dissipated in the form of friction by using a mechanical damper in the cylindrical hole in the center of standard end mill[41].

Wang [5] proposed a non-linear tuned mass damper (TMD) equipped with an additional series of friction-spring element. The capability of this type of non-linear TMD showed that the stability increased the critical limiting depth of cut by 30% as compared to the optimally tuned linear TMD. Wang et al. [53] also proposed another non-linear TMD

with an additional element of elastic support dry friction which absorbed energy by both sliding friction and vibration of its own mass to suppress chatter in turning process. A laminated clamping device was made up of steel and a hard-rubber visco-elastic material was proposed to hold the cutting tool and suppress chatter [54].

### **2.2.2.2 Active Chatter Suppression**

Active elements are able to monitor the dynamic state of machine tool system which later can take an action to change the process and suppress chatter. Active chatter control suppression techniques have been very popular due to its precise controlling and decision making ability. The successful active chatter suppression techniques include actively varying process parameters such as feed rates and spindle speeds [7], varying the rake angle and clearance angle [8], and monitoring the force signal [9]. Also, a delayed resonator was used to eliminate chatter [55, 56].

#### **1. Spindle Speed Variation (SSV)**

The technique of using SSV was believed to distort the regenerative chatter[57]. This method was widely used for chatter suppression, mostly effective for low spindle speed[1]. Al-Regib et al. [58] purposed a method for programming spindle speed variation for machine tool chatter suppression. A procedure to select the frequency and an amplitude was also presented systematically. Most of the SSV methods were based on sinusoidal change of rotational speed[59]. Lin et al. [60] discussed about the use of variable speed cutting for vibration control in the face milling process. It was predicted that the self-excited vibration that occurs during constant speed cutting can be suppressed by continuously varying the spindle speed. Cao et al. [61] presented an approach to predict

the chatter stability lobes for high speed milling considering speed varying spindle dynamics. It was shown that the stability increases with the change in spindle speed.

Zatarain et al. [62] presented a general theory for analysis in the frequency domain and any spindle variation technique. Bediaga et al. [63] developed a strategy to obtain stability in high speed milling. The strategy tend to detect the chatter in accordance to the stability lobe diagram and suddenly suppress chatter either by taking machine to the stable spindle speed or causing SSV. A similar method was utilized with variable pitch mill to distort the regenerative chatter. Slavicek [64] investigated an effect of variable tooth pitch on stability. The rectilinear tool motion was assumed for the cutting teeth and the orthogonal stability theory was applied to irregular tooth pitch. A stability limit as a function of the variation of pitch was obtained. Budak [65] presented an analytical stability and design models for non-constant pitch cutters. The relation between stability limit and the pitch variation was obtained and claimed the improved stability, productivity and surface finish. It was demonstrated that the pitch mill variation can also suppress chatter. However, SSV is highly used because it is more flexible as compared to variable pitch mill. Despite an easy implementation of SSV, an industrial application of this chatter suppression technique is still difficult due to the high cost and the need of quick response for SSV. Therefore, research on finding other elements is in progress to actively suppress chatter.

## 2. Active Elements

The active elements such as computers, sensors and actuators can actively suppress chatter by monitoring chatter and executing the decisions to change the cutting parameters if necessary. Active damping devices are also used for chatter suppression. These devices forces energy into the system which in turn compensates the self-excited vibration of machine tool system and suppresses chatter.

Tewani et al. [66] used an active dynamic absorber to suppress machine tool chatter in a boring bar. The vibration of the system was reduced by moving an absorber mass using an active device to generate inertial force and counteract the disturbance acting on the system. A boring bar with the passive tuned dynamic absorber and active dynamic absorber were compared where the higher stability was obtained for the latter one. Mei [67] used an active vibration controller in a non-rotating boring bar to absorb chatter vibration energy in a broad frequency range.

The smart materials were extensively used to suppress chatter. Smart materials exhibited piezoelectric effects, magnetostrictive effects as well as materials such as magnetorheological (MR) and electrorheological (ER) fluids, ionic fluids and shape memory alloys [68]. Brecher et al. [69] presented a systematic approach to suppress chatter through the integration of an active workpiece holder with two high dynamic axes controlled by piezoelectric actuators onto the milling system. Mei et al. [70] developed a chatter suppression method based on MR fluid controlled boring bar where MR fluid changed the stiffness and adjusted the strength of the applied magnetic field. Choudhury et al. [71] developed an on-line vibration control on a turning lathe using a piezoelectric vibrator mounted on the tool. An optical sensor was used to sense the vibration between

the workpiece and the tool while the vibrator exciter was used to generate the opposing force to stabilize the vibration. A fuzzy logic controller was used which adaptively selected amplitudes and frequency in peripheral milling to suppress chatter [72, 73]. An adaptive control system was developed based upon the adaptive algorithm called filtered X-LMS. A piezo-actuator was employed to control the dynamic force which was experimentally proved [74]. Similar method was used to avoid the unwanted vibration by using the workpiece holder with adjustable stiffness variable stiffness holder [75]. A generalized methodology of chatter suppression was implemented in modern milling machines [6]. A strategy was developed to match the spindle speed to optimal phase shift between two subsequent passes of tool edges which could only be applied when the chatter was underdeveloped and didn't apply for the one where the chatter was already developed. Also, an active vibration control was used in milling flexible workpiece [76]. This work was completely based on 1-DOF where the workpiece exhibited only one dominant direction of vibration.

### **2.2.3 Vibration Assisted Machining for Chatter Stability**

Xiao et. al [27] developed an experimental model to study the precision machining mechanism of vibration cutting which can provide an effective control solution to the chatter problem. It was shown that chatter was suppressed in Ultrasonic Vibration Assisted Machining (UVAM) regardless of the tool geometry, which otherwise had significant effect on conventional machining. It was claimed that UVAM always achieved a higher cutting stability as compared to conventional cutting. Tabatabaei et. al [51] developed a theoretical model on the effect of ultrasonic vibration assistance on chatter. The regenerative chatter suppression for high chip removal was presented by considering

bending mode of the tool. Yao et. al [52] presented a chatter control system on the basis of harmonic excitation of a workpiece for orthogonal cutting. It was shown that the parametric excitation with an appropriate frequency and large amplitude can suppress chatter effectively. Ma et. al [50] proposed a theoretical model to suppress chatter by adding ultrasonic elliptical vibration on the cutting tool. The experimental investigations showed that the regenerative chatter occurring in ordinary turning operation was effectively suppressed by applying ultrasonic elliptical vibration. Overall, the findings from these studies have consistently shown the significant effect of vibration assistance on the chatter vibration system. However, the methods listed above are focused on the turning process, hence the results cannot be implemented to milling operations due to the difficulties to excite the rotating milling tool.

#### **2.2.4 Surface Texturing using Vibration Assistance**

Surface texturing is a surface engineering approach by improving an interaction between the tool and the workpiece to enhance the tool performance in machining and create various useful patterns. The surface textures in the past were created in orthogonal cutting by using vibration assistance in two directions by changing the tool tip trajectories in various patterns. Guo and Ehmann [11] developed a 2D tertiary motion generator (TMG) for elliptical vibration texturing. The TMG was then used for the fast generation of textured surfaces. The shape and vibration amplitudes which plays an important role in surface texturing was considered in this design which successfully created micro/meso scale features in an engineered surfaces. The same group of researchers extended their research by analyzing the surface generation mechanics on an elliptical vibration texturing process through experimentation and modeling [77]. In this study, the influence of the process

parameters on the texture pattern was characterized through the simulation model. Also, the effect of the tool geometry including the cutting edge radius on the process was analyzed.

Guo et al. [78] proposed the elliptical vibration texturing process for the generation of spiral micro-channels on cylindrical surfaces. In this study, an analytical model was established to predict channel formation with respect to overlapping ratios of the dimples. The model was then verified by the experimental results. Guo et al. [79] applied elliptical vibration cutting to the generation of hierarchical micro-structures which can be applied to create artificial super-hydrophobic surfaces. The anisotropic wetting in the surface with parallel channels was shown to be enhanced significantly by the hierarchical structures. Subbiah et al. [80] proposed a new method of micro- texture generation in precision machining by controlled self-excited chatter of diamond cutting tool. The method to generate a micro-textures of various shapes which can be utilized in micro channels and micro cavities for mass and heat transfer applications was presented. The shape of the texture was suggested to depend on the cutting tool shank, cutting speed, feed and cutting depth. Suzuki et al. [81] developed a novel technique of vibration assistance in turning using an off-the-shelf piezoelectric actuator, its control system and conventional cutting tool. Yan et al. [82] generated a mico-surface structures on oxygen-free copper and RB-SiC using a single-crystalline diamond ball end mill in a 4-axis numerical controlled ultraprecision machine tool.

In this thesis, a new experimental strategy is developed to generate the surface texture in milling with 2D vibration assistance. The effect of external vibration, different feed rates and tool geometries on surface texture generation is discussed.



## 2.4 Summary

Self-excited vibration is a major source of poor surface finish, increased tool wear, and poor dimensional accuracy. Number of research works in the past were performed to predict and suppress/reduce chatter. Both active and passive chatter reduction/suppression techniques were successfully used in the machining processes. Active chatter control is the most popular technique for chatter reduction/suppression. This technique is easy to enhance the stability in any machining processes as it doesn't require a model of the system and it is robust. However, this technique is more expensive because the system requires more complex hardware and software. It also requires second vibration source to increase the total energy of the vibration waves. This technique may lead to instability in the system due to continuous monitoring and controlling process. Moreover, the chatter frequencies dealt with in the previous works are all below 1000 Hz due to the limitation of controller bandwidth. In micro-milling process the chatter frequency ranges from 4,000 to 10000 Hz due to reduced size of the cutting tool. Therefore, a passive chatter control technique is applied in this thesis which can reduce chatter at high frequency. Surface texturing using vibration assistance is a novel technique in the field of mechanical tribology. The shape and pattern of the textures depend on the shape of the trajectory created by using different frequencies and amplitudes, cutting speed, feed rate and the tool geometry. These patterns can be used in a friction reduction, self-cleaning surfaces and heat exchangers. The surface texture generation using vibration assistance is applied in the past but they are limited to turning. Hence, surface texture generation with vibration assistance in micro milling is investigated in this thesis.

VAM offers numerous advantages over conventional machining because of its ability to reduce the cutting force, surface roughness and tool wear. Mostly piezoelectric materials are used to perform VAM. These material produce an electric charge when they are mechanically stressed. These materials are widely used in structural dynamics applications because they are light weight, powerful, inexpensive and they come in variety of forms.

This thesis investigates the effect of 2D vibration assistance on high frequency regenerative chatter and surface texture generation in micro milling process. A vibration stage driven by the piezoelectric actuator is used to provide high frequency vibration assistance on the workpiece in feed and normal directions. The effects of vibration direction, amplitude and frequency on chatter amplitude and surface texturing is investigated. The experiments are performed by applying external vibration in 1D and 2D, respectively. The chatter amplitude between CM and VAM is compared and analyzed. Besides vibration parameters, the effect of helix angle is also studied in surface texturing. Slot milling and side milling is performed to study the chatter amplitude and surface texturing respectively.

## **CHAPTER 3**

### **ATTENUATION OF REGENERATIVE CHATTER IN VIBRATION ASSISTED MICRO-MILLING**

#### **3.1 Overview**

This chapter explains the experimental setup and procedures used to obtain the dynamics at the tool tip and detect chatter. The experimental result, its analysis and discussion is also presented in this chapter. A Computer Numerical Controlled (CNC) milling machine with carbide squared end mill is used to conduct this research. The dynamics of a machine tool structure is measured by using hammer test in order to predict the maximum stable depth of cut as a function of spindle speed. The chatter during the cutting tests is recorded using microphone. A brief introduction to the identification of frequency response function (FRF) and chatter test is presented.

#### **3.2 Experimental Setup**

The dynamics of the machine tool structure is important to determine the maximum stable depth of cut as a function of spindle speed which can be determined by the hammer test. In this test, the machine tool structure is excited by hitting it with an impulse force hammer. This impact excites the structure at a certain frequency range. The energy transmitted to the structure and magnitude of the exciting force by the impact is determined. The dynamics of the structure is then determined through the response by hammer test

measured by an accelerometer. The dynamic characteristics are determined by combining the Fourier-spectrum of both the impact force and the displacement/acceleration measurement. The combination of measurement of force and displacement results in the frequency response function (FRF). FRF is a plot of the dynamic stiffness [N/m, lbf/in] of the structure as a function of frequency [Hz] [83].

### 3.2.1 Prediction of Chatter Stability Lobe

The dynamic behavior of the spindle-tool holder-tool system is the limiting factor for machining processes in the milling machine tool due to its flexibility. Therefore, it is important to model the machine tool to be flexible. In milling tests, a hammer test is performed on the tool to determine the dynamic property of the structure as shown in Figure 3.1. In this test, the frequency range that can be excited by a hammer is inversely proportional to the contact time of the impact. The frequency range which can be excited properly by the hammer is also dependent on the type of tip used. The tip influences the contact time and the contact force. In order to get a good dynamic characterization of the structure (FRF), the structure is excited with an approximate force in the frequency range of interest. Therefore, it is important to know the characteristics of the forces exciting the structure in advance.

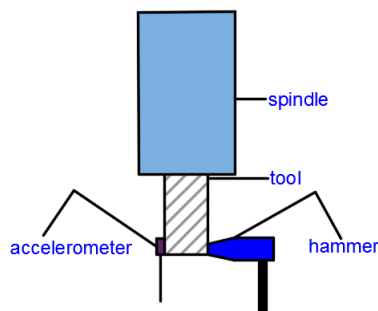

Figure 3.1 Schematic for impact hammer test

An accelerometer is used to measure the vibration and transfer function. The mass and the frequency range of an accelerometer is selected properly, because accelerometer mounted on the structure acts as an extra mass and may alter the frequency characteristics of the system. The bonding and interface materials between the structure and accelerometer is also selected carefully in order to obtain an accurate measurement. These materials have to transmit the vibration of the structure properly.

In hammer test, several measurements are taken and averaged in order to minimize errors. FRFs of the tool in both feed and normal directions are measured and plotted in Figure 3.2. In Figure 3.2 there are two large peaks at frequency 2300 Hz and 3400 Hz which represents the weakest points of the structure. Lower frequency represents the high mass while the higher frequency represent the low mass. The higher frequency 3400 Hz is the critical location in this analysis.

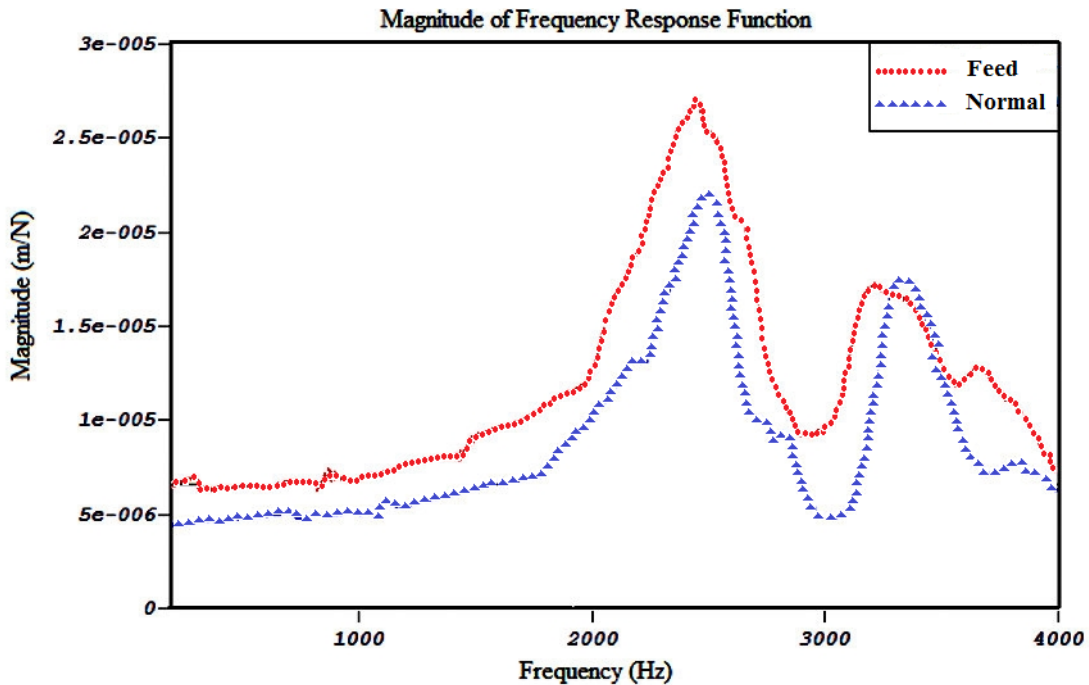

Figure 3.2 FRFs in feed and normal directions at the tool tip

Once FRF on the machine tool is measured, the chatter stability lobe for the slot milling condition is obtained using the commercial machining simulation and optimization software CutPro [84] as shown in Figure 3.3. A spindle speed dependent dividing line between the stable and unstable depth of cut for a certain width of cut is represented in the stability lobe diagram (SLD). In SLD the location above the lobe represents the unstable cutting condition and the location below represents the stable cutting condition. Using a SLD is the most efficient way to select the optimal cutting conditions instead of trial and error based test. FRFs measured at the tip of the tool in X and Y directions are used in CutPro simulation. The geometric properties of the cutter such as tool radius, helix and rake angle is also recorded. The existing cutting force coefficients of Al 6061 is used in CutPro for the stability lobe calculation.

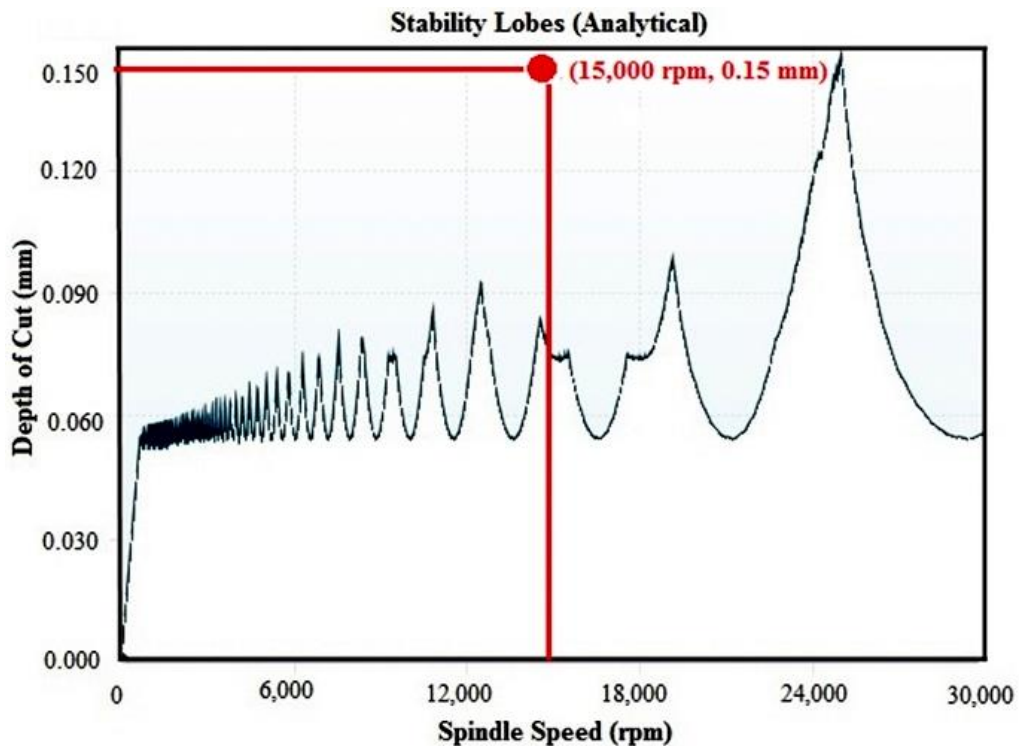

Figure 3.3 Stability lobe diagram

### 3.2.2 Chatter stability of micro milling

The vibration assisted micro-milling experiments are conducted on a MDA precision machining center with the maximum spindle of 60,000 rpm. Aluminum alloy (AL 6061) workpiece and a two flute squared end carbide tool with the diameter 3.175 mm and the helix angle of 30° is used. The experimental setup for the micro-milling test is given in Figure 3.4 and Figure 3.5. The range of material composition of an aluminum alloy used for this experiment is provided in Table 3.1.

Table 3.1 Aluminum 6061 composition

Material	Si	Fe	Cu	Mn	Mg	Cr	Zn	Ti	V	Zr
Min (wt %)	0.40	0.0	0.15	0.0	0.8	0.04	0.0	0.0	0.0	0.0
Max (wt%)	0.8	0.7	0.40	0.15	1.2	0.35	0.25	0.15	0.05	0.05

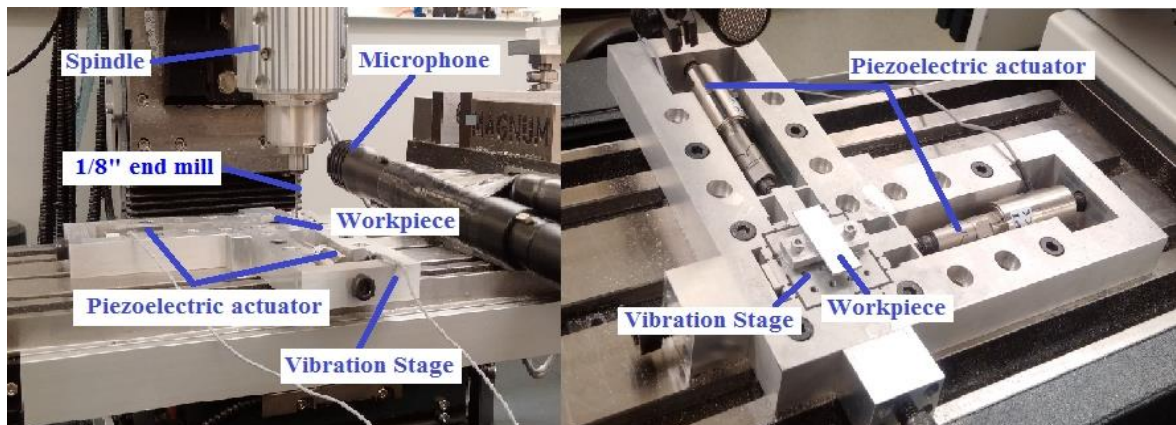

Figure 3.4 Experimental setup

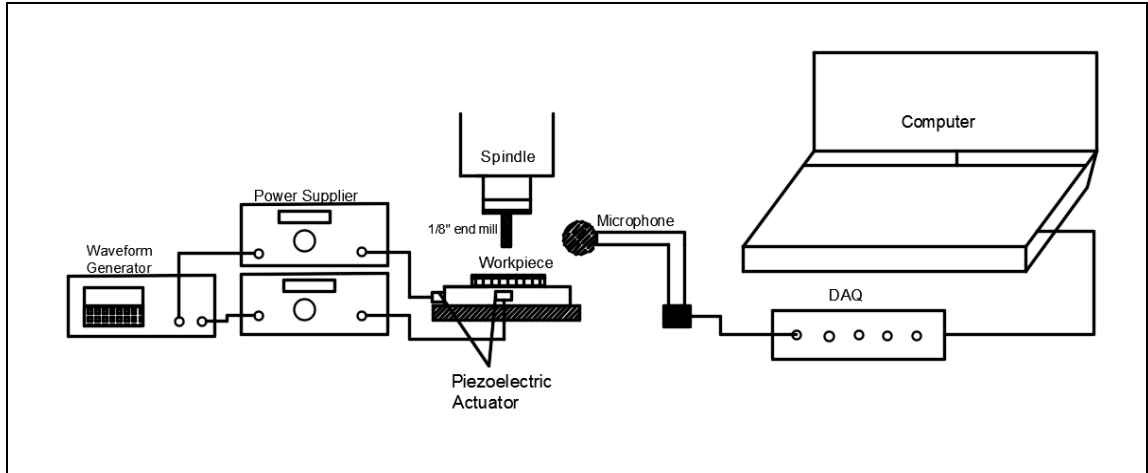

Figure 3.5 Schematic of the experimental system

A piezoelectric driven 2-D vibration stage is used as shown in Figure 3.6. The stage is made of aluminum with flexure design. The geometry of the structure is determined to ensure the displacement of the piezo-actuator tip is amplified at the center of the vibration stage where the workpiece is mounted. Physik Instrument piezoelectric actuator (model: P844.10) with maximum travel range of 15  $\mu\text{m}$  and frequency range of 18 kHz is employed. The maximum pushing force of the actuator is 3000 Newton. The piezoelectric actuator is excited by high-power amplifier which receives the high frequency voltage from a signal generator. A dynamic property of the vibration stage is first determined by measuring the displacement using Lion Precision displacement sensor (COL 290) with a bandwidth of 15 kHz and 0.25 nm resolution. It is found that the vibration stage is amplified in the frequency range of 5-11 kHz. The maximum vibration amplitude of the stage is 10  $\mu\text{m}$  at the resonance frequency.



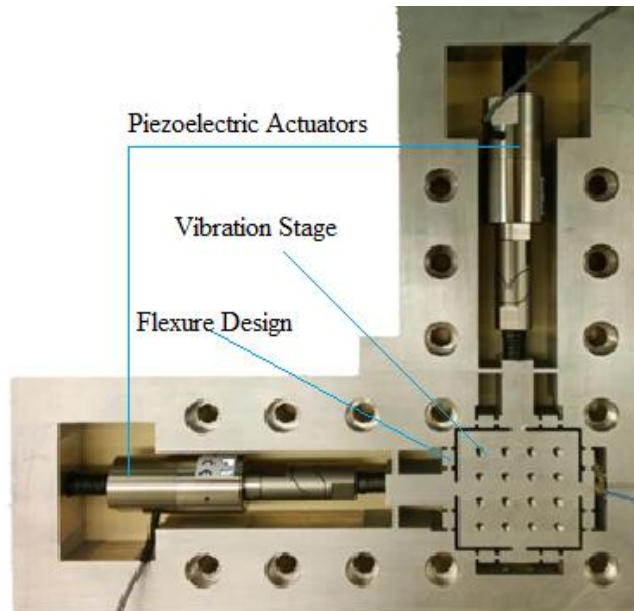

Figure 3.6 2D vibration assisted stage

### 3.3 Experimental Procedures

The workpiece is fixed on the vibration stage and the vibration stage is excited using piezoelectric actuators. During the milling test, the displacement sensor is used to monitor the real-time vibration of the workpiece. The depth of cut (0.15 mm) and spindle speed (15,000 rpm) is selected to intentionally cause obvious chatter in milling process. The chatter vibration is monitored using the sound pressure signal measured by a microphone. The sound recorded by the microphone is represented by the voltage and sent to the data acquisition card. FFT of the time-domain signal at different cutting conditions and vibration parameters is analyzed to detect the chatter vibration strength. The main purpose of this experiment is to determine the effect of applied vibration on chatter amplitude. Therefore, the cutting tests are performed with and without external vibration. In order to avoid errors due to non-homogeneous property of the workpiece material, the tests are performed without vibration assistance, with 1-D vibration in feed and normal

direction respectively, and with 2-D vibration in the same cutting path. In addition, a series of frequency and amplitude of the vibration excitation are applied to investigate the effect of assisted vibration on chatter.

### 3.4 Experimental Results

The sound signal collected from the microphone is shown in Figure 3.7- Figure 3.9 which corresponds to the cutting condition listed in Table 3.2. Figure 3.7 shows the FFT of the background sound signal before the tool is in contact with the workpiece. It is shown that all the frequency components of the sound are below 0.0002V. In Figure 3.8 microphone data gives the highest peak at  $\omega_c = 4342 \text{ Hz}$  during the micro-milling without vibration assistance. The corresponding spindle and tooth frequencies are  $\omega_s = 250 \text{ Hz}$  and  $\omega_T = 500 \text{ Hz}$  respectively. The other peaks are the tooth passing frequency harmonics and at  $\omega = \omega_c \pm \mathbf{1}\omega_T$  which demonstrates the occurrence of regenerative chatter. The chatter frequency, spindle frequency and tooth passing frequency in VAM and CM are similar as shown in Figure 3.9 and Figure 3.8 respectively. However, the chatter amplitude is 0.0032V in CM and 0.00125V in VAM which is reduced by more than 50%. The peak at 8 kHz in Figure 3.9 reflects the sound produced by the piezoelectric actuator, and is not from the tool-workpiece interaction

Table 3.2 Cutting parameters in CM and VAM

Vibration Parameters	Frequency (kHz)	8
	Amplitude ( $\mu\text{m}$ )	10.3
Feed Rate ( $\mu\text{m}/\text{flute}$ )		5
Radial Depth of Cut (mm)		3.175
Spindle Speed (rpm)		15000
Axial Depth of Cut (mm)		0.15

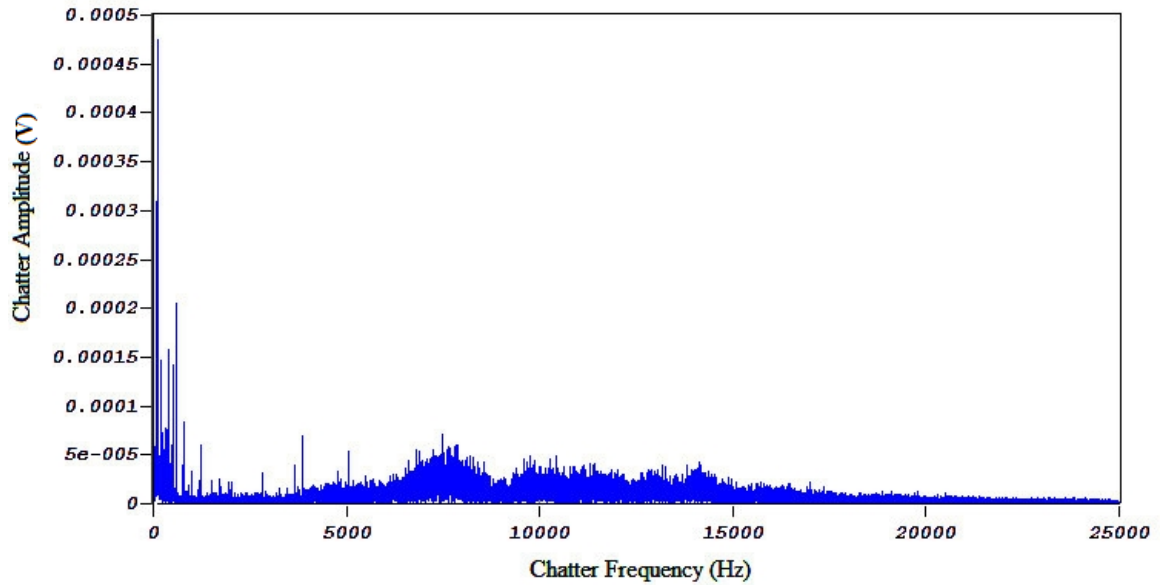

Figure 3.7 Frequency domain signal for air cutting

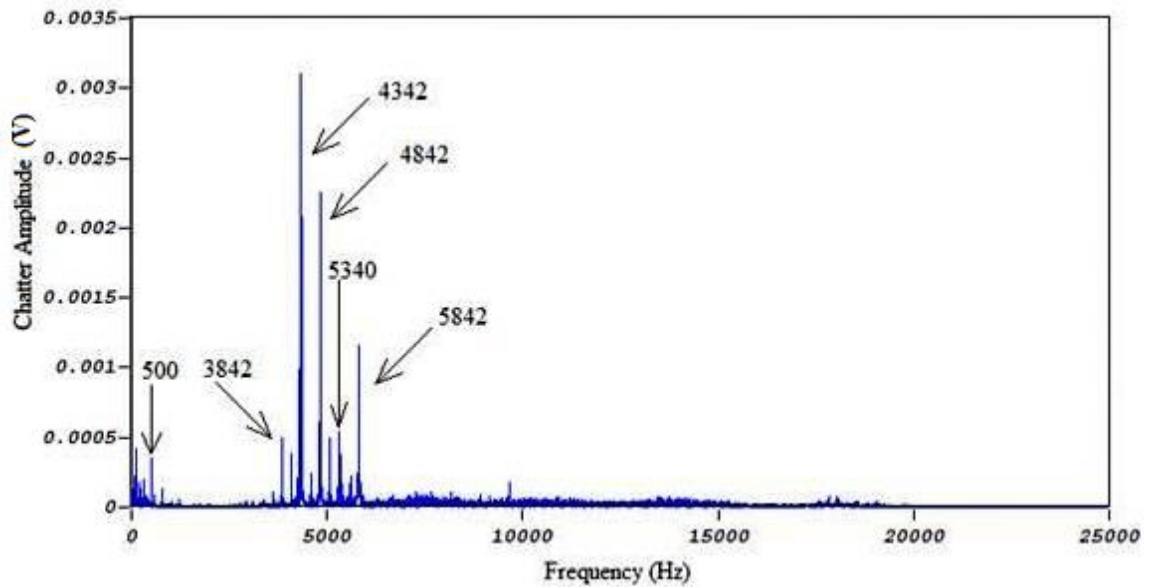

Figure 3.8 Frequency domain signal for milling without vibration assistance

A series of milling tests were conducted with different cutting conditions and assisted vibration parameters. The chatter amplitude at each condition is studied and analyzed between CM and VAM when vibration is applied in 1-D at feed and normal direction respectively as well as in 2-D. The experimental results and the analyses are presented below.

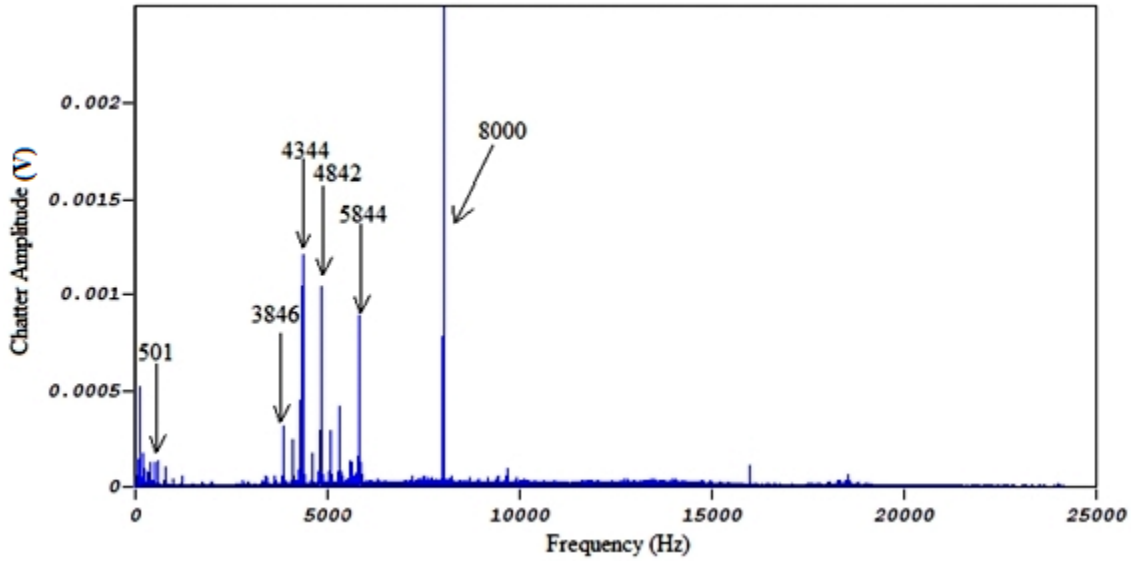

Figure 3.9 Frequency domain signal for vibration assisted milling

### 3.4.1 Chatter Amplitude in 1-D Vibration Assisted Milling

The cutting tests are performed when the vibration is applied in feed and normal directions respectively to determine the chatter amplitude between CM and VAM. All the cutting parameters are kept constant throughout the experiment except the vibration amplitude as shown in Table 3.3.

Table 3.3 Cutting parameters in 1D VAM

Vibration	Frequency (kHz)	8
Parameters	Amplitude ( $\mu\text{m}$ )	1.32, 2.4, 5, 8.82
Feed Rate ( $\mu\text{m}/\text{flute}$ )		7.5
Radial Depth of Cut (mm)		3.175
Spindle Speed (rpm)		10,000
Axial Depth of Cut (mm)		0.15

Figure 3.10 - Figure 3.11 shows the comparison of chatter amplitude between conventional milling and 1-D vibration assisted milling in feed and normal direction respectively. The frequency of the vibration assistance is 8 kHz, and the amplitude varies in the range of 1-9  $\mu\text{m}$ . In order to ensure the repeatability of the results, in each test, five

sections of the time-domain vibration signals are picked and converted into frequency domain, with the duration of each section as 1.5 seconds. The average chatter amplitude between CM and VAM in feed and normal direction is compared. It is found that the reduction of average chatter amplitude when the vibration assistance is applied in feed direction is around 36%, while in the normal direction is 29%. Therefore, it is concluded that the application of vibration assistance with the amplitude of 1-9  $\mu\text{m}$  is able to effectively reduce the chatter amplitude.

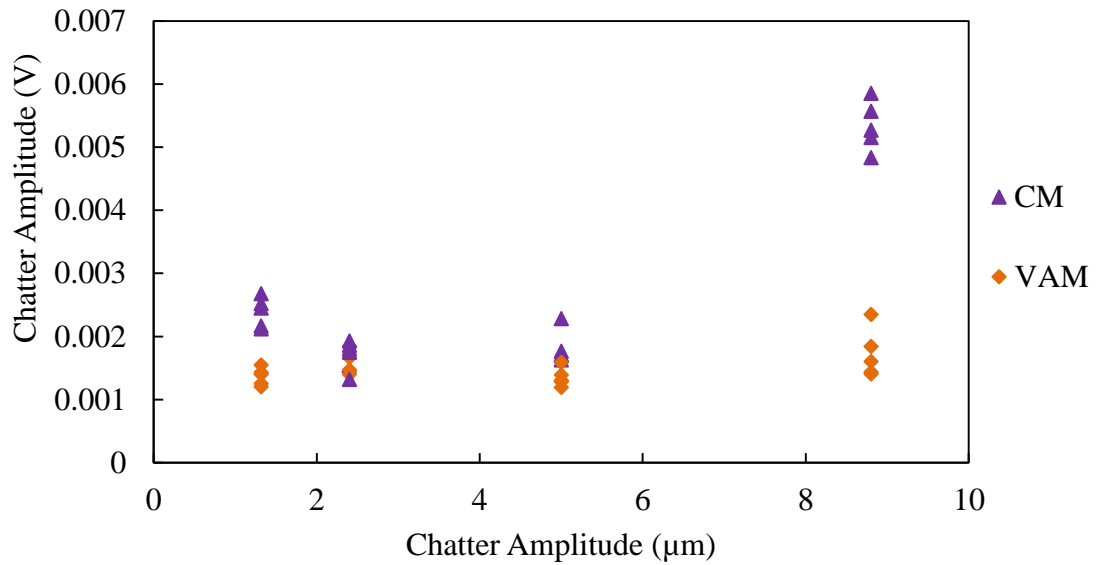

Figure 3.10 Chatter amplitude in feed direction

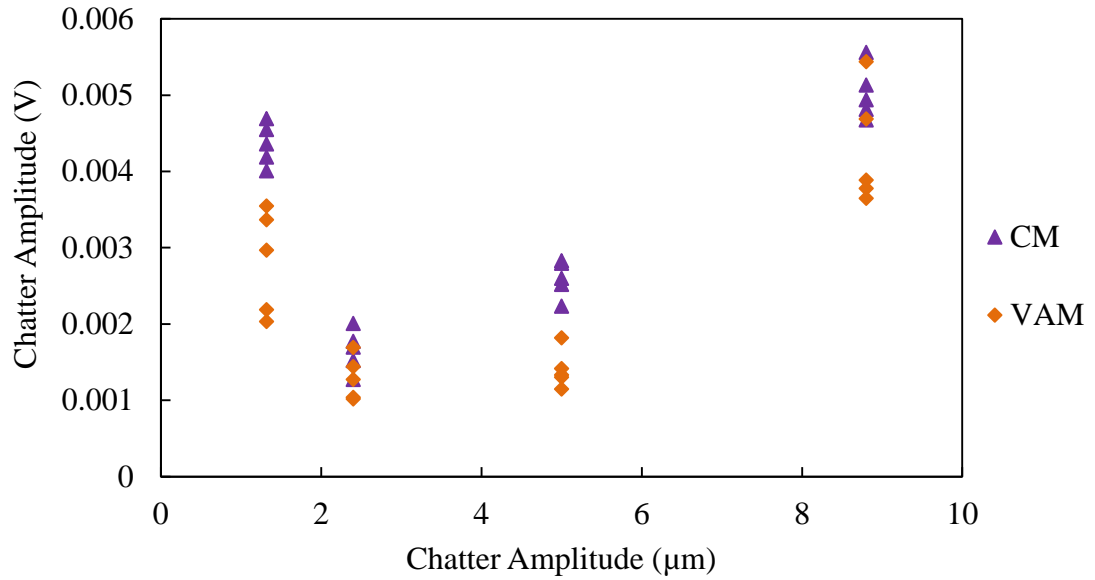

Figure 3.11 Chatter amplitude in normal direction

Experiments are repeated with the same cutting and vibration parameters as in Table 3.3 to ensure the repeatability of the results. The repeated results are given in Figure 3.12 and Figure 3.13. It is observed that the magnitude of the chatter amplitude in CM and VAM changed as compared to previous results. The inhomogeneous properties in an aluminum alloy and tool wear could be the reason for the change in chatter amplitude despite the same cutting conditions. However, it is found that the reduction of average chatter amplitude when the vibration assistance is applied in feed direction is around 33%, while in normal direction is 27% which is close to 36% and 29% respectively from previous studies. Hence, the average chatter reduction with the vibration assistance is considered in this thesis.

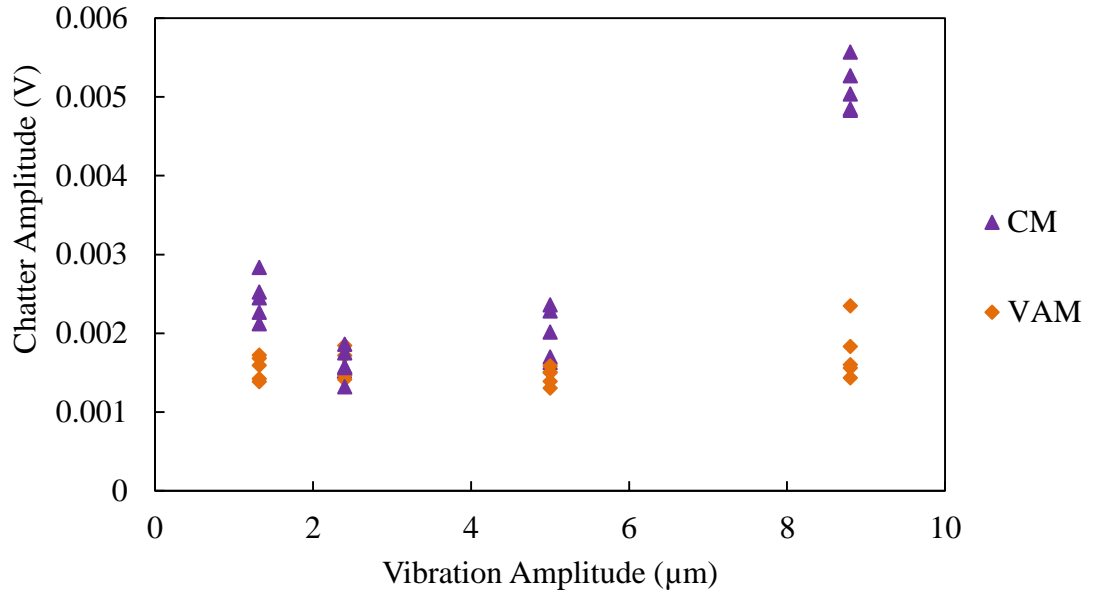

Figure 3.12 Chatter amplitude in feed direction (repeated)

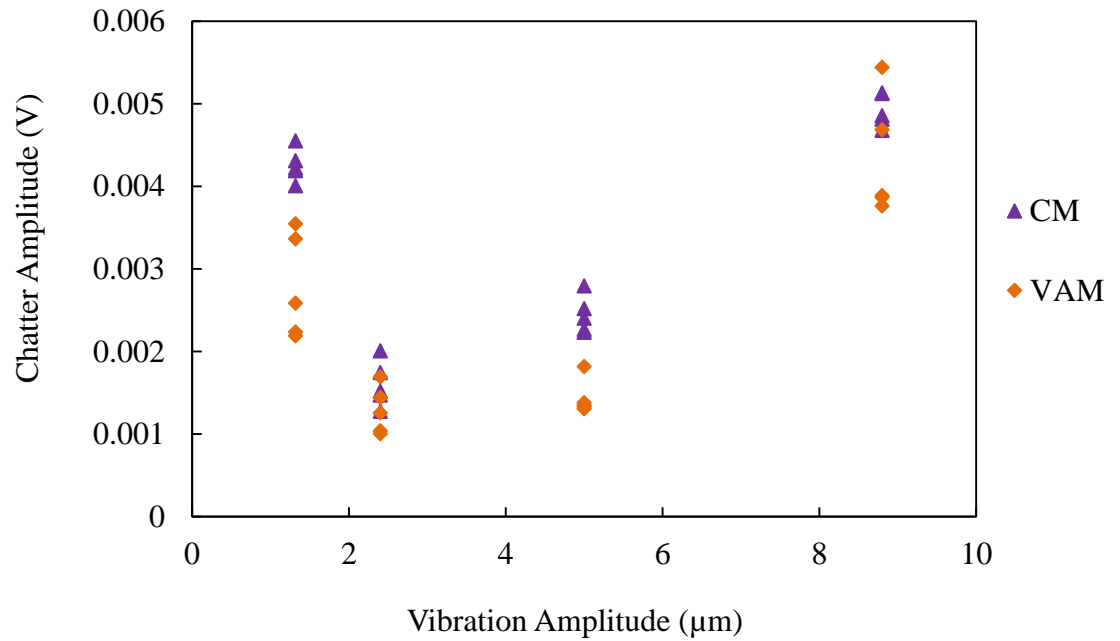

Figure 3.13 Chatter amplitude in normal direction (repeated)

Experiments are performed when the 1-D vibration assistance is applied at different excitation frequencies, with the measured chatter amplitude shown in Figure 3.14 – Figure

3.17. The cutting and vibration parameters are given in Table 3.4. At each frequency, a range of vibration amplitudes are tested depending on the capability of the vibration stage. The results also show that the chatter amplitude in VAM is reduced by 25-30% as compared to the CM. The chatter reduction rate is higher when the vibration amplitude increases. For majority of the measurements, the ratio of chatter amplitude between CM and VAM increases with the increase of vibration amplitude.

Table 3.4 Cutting Parameters in 2D VAM

Vibration Parameters	Frequency (kHz)	5, 7, 8, 9
	Amplitude ( $\mu\text{m}$ )	0.11-10.3
Feed Rate ( $\mu\text{m}/\text{flute}$ )		5
Radial Depth of Cut (mm)		3.175
Spindle Speed (rpm)		15,000
Axial Depth of Cut (mm)		0.15

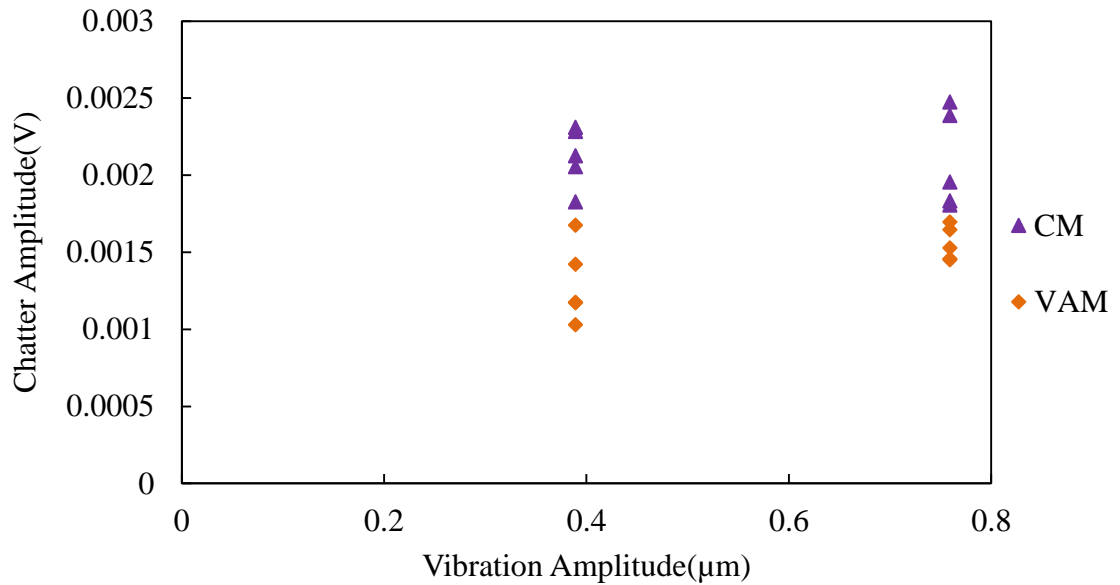

Figure 3.14 Chatter amplitude with vibration assistance at 9 kHz



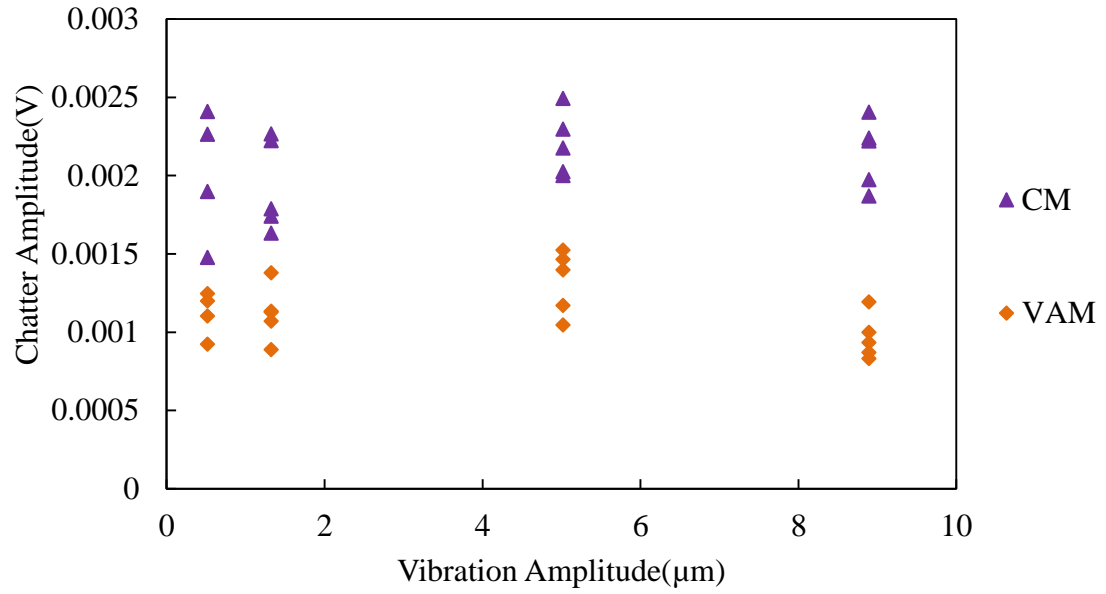

Figure 3.15 Chatter amplitude with vibration assistance at 8 kHz

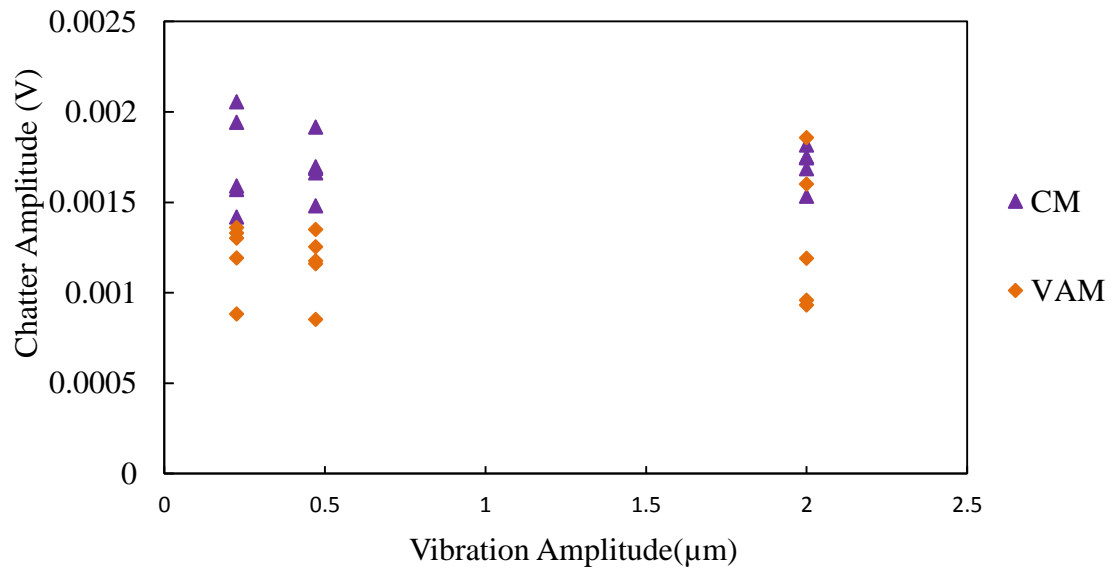

Figure 3.16 Chatter amplitude with vibration assistance at 7 kHz

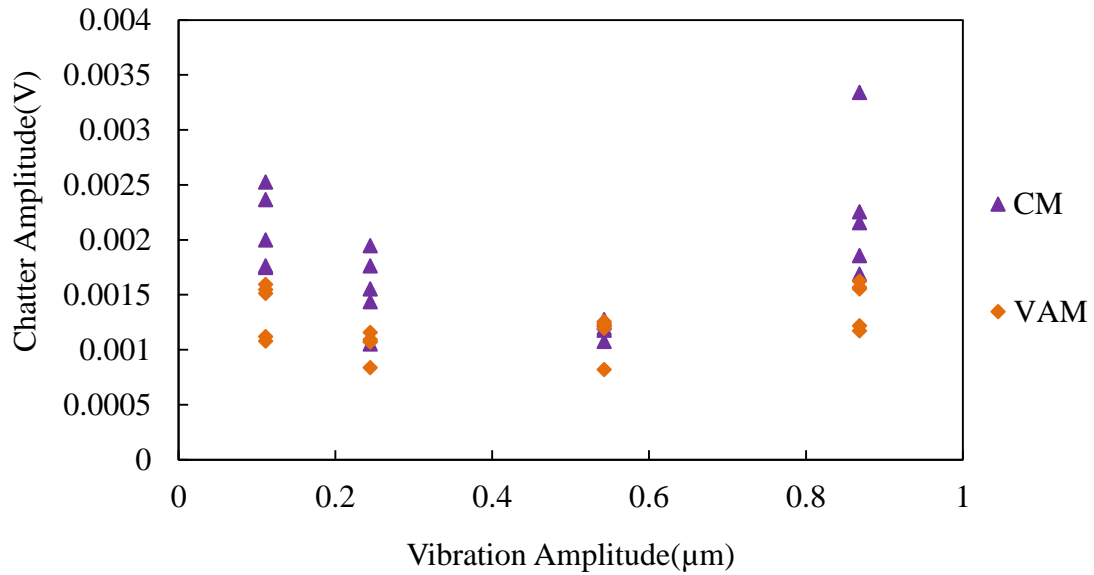

Figure 3.17 Chatter amplitude with vibration assistance at 5 kHz

### 3.3.1 Chatter Amplitude in 2-D Vibration Assisted Milling

Experiments are conducted to study the effect of vibration assistance on chatter amplitude when the vibration is applied in 2-D at the same time. The same cutting and vibration parameters are used for 2-D as in 1-D is shown in Table 3.4. The result in Figure 3.18-Figure 3.21 shows that the chatter amplitude in 2-D VAM is significantly lower as compared to CM. The percentage of average chatter reduction in 2-D vibration is 30-44% which is almost 10% higher than the results obtained from 1-D vibration. It is concluded that the application of 2-D vibration assistance is able to effectively attenuate the regenerative chatter in the frequency range of 5-9 kHz and the amplitude of 0.1 – 10 μm.

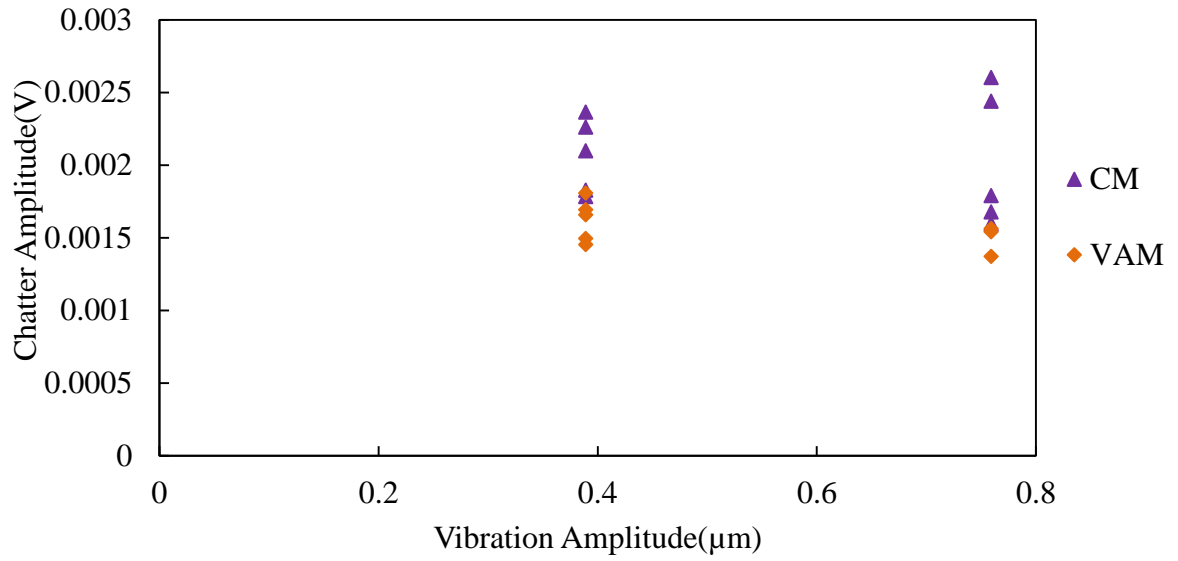

Figure 3.18 Chatter amplitude with 2-D vibration assistance at 9 kHz

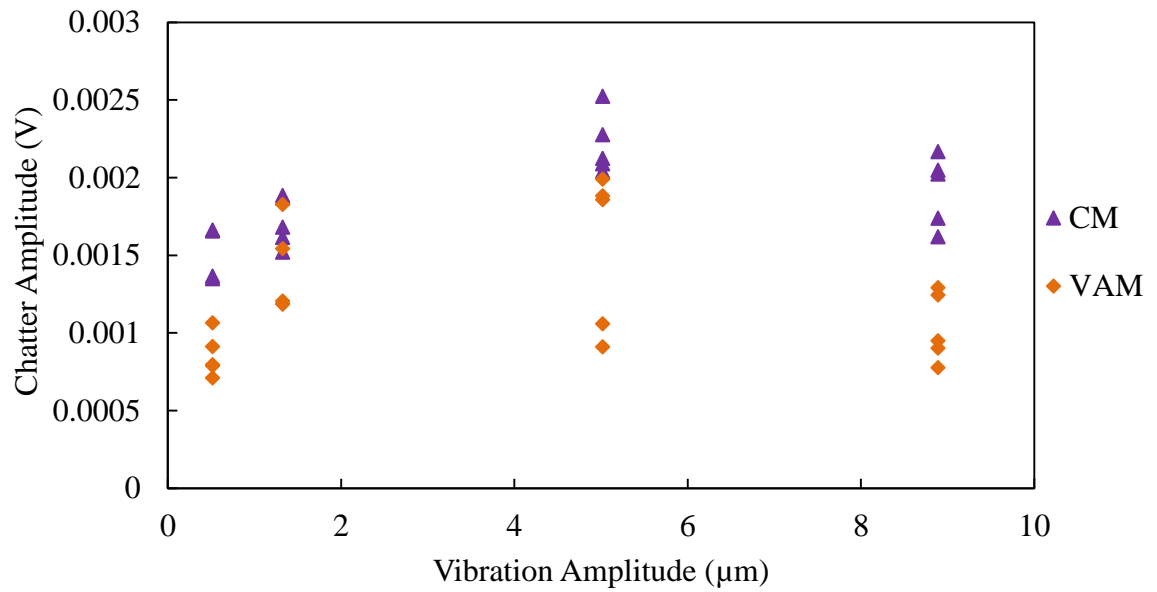

Figure 3.19 Chatter amplitude with 2-D vibration assistance 8 kHz

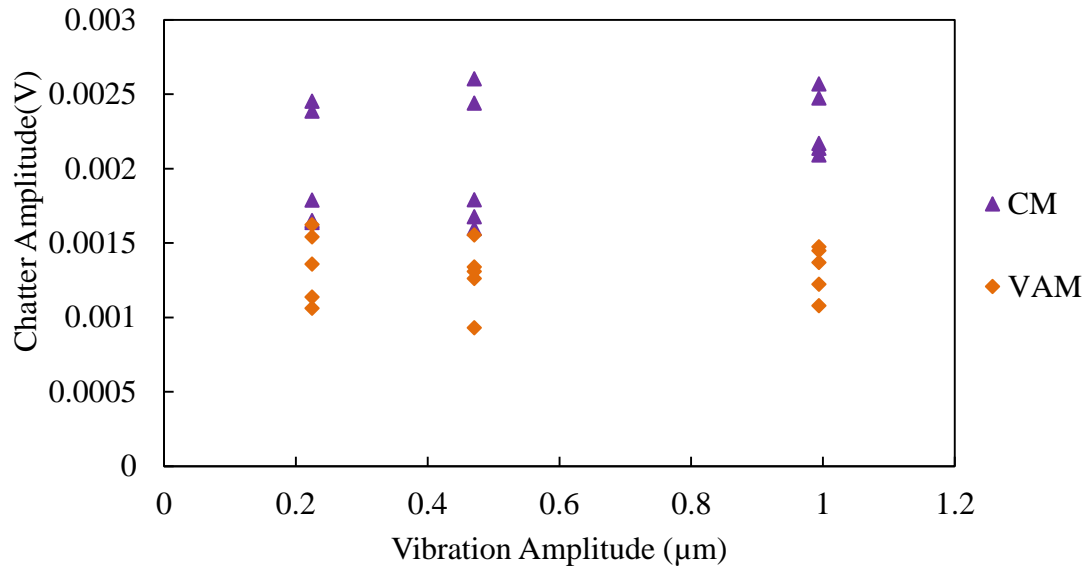

Figure 3.20 Chatter amplitude with 2-D vibration assistance at 7 kHz

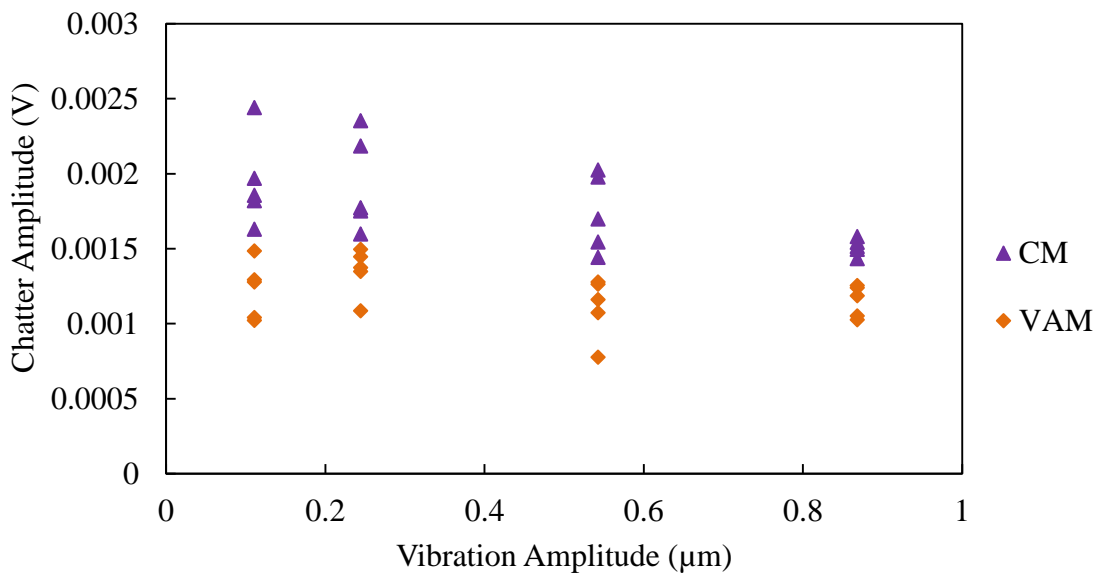

Figure 3.21 Chatter amplitude with 2-D vibration assistance at 5 kHz

### 3.4 Chatter Amplitude with Feed Rate

The cutting tests are performed to study the effect of feed rate on chatter amplitude in both CM and VAM. It is generally known that the feed rate doesn't influence the chatter stability since it only changes the static chip thickness. However, in micro milling process with the feed rate below 15 μm, the tool edge radius is in the same size order of the feed

rate, therefore, the relationship between the force and feed rate becomes nonlinear [85] which influences the chatter stability. The cutting parameters used in this test are given in Table 3.5. All the cutting parameters are constant except feed rate which ranges from 1-15  $\mu\text{m}/\text{flute}$  throughout the experiment. Figure 3.22 shows the measured chatter amplitude with respect to the feed rate with and without vibration assistance. The results demonstrates that the assisted vibration is able to attenuate the regenerative chatter in the defined range of feed rate which is typical in the micro milling applications.

Table 3.5 Cutting parameters

Vibration Parameters	Frequency (kHz)	8
	Amplitude ( $\mu\text{m}$ )	5
Feed Rate ( $\mu\text{m}/\text{flute}$ )		1-15
Radial Depth of Cut (mm)		3.175
Spindle Speed (rpm)		15,000
Axial Depth of Cut (mm)		0.15

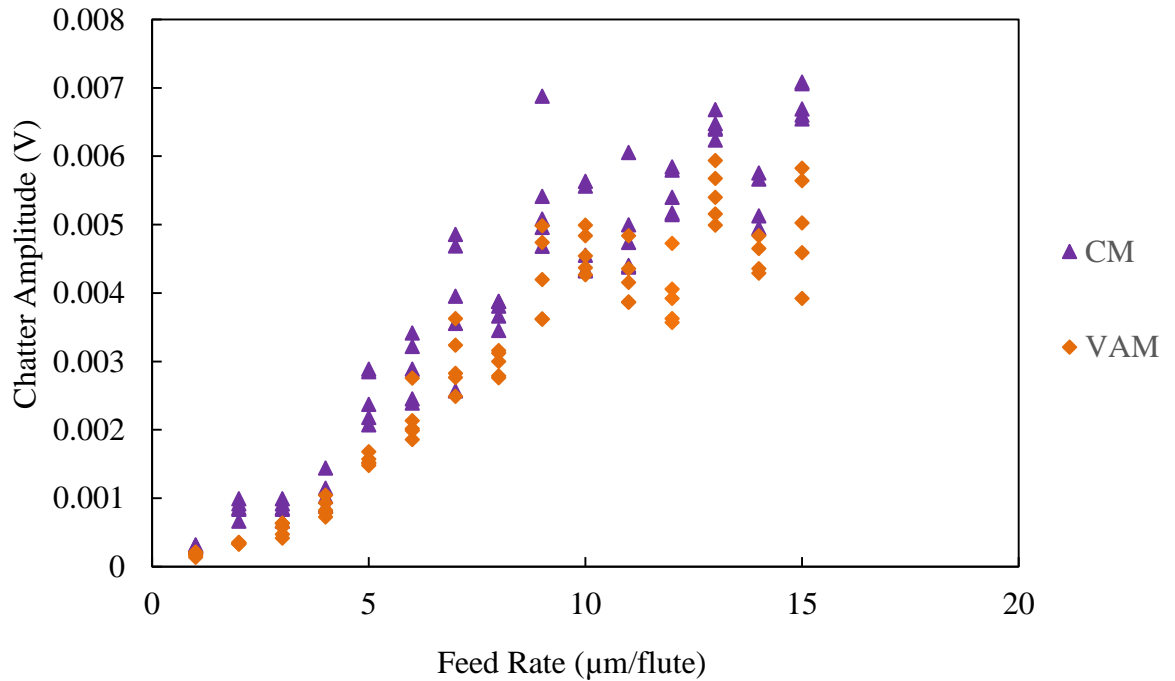

Figure 3.22 Chatter amplitude in conventional and vibration assisted milling

### 3.5 Analysis and Discussion of Vibration Assistance on Chatter Amplitude

Figure 3.23 shows the schematic of the conventional milling and vibration assisted milling processes. Regenerative chatter occurs due to the dynamic chip formation when tool tip trajectories in two consecutive passing periods are out of phase [36]. Part (a) in Figure 3.24 shows the chip formation in CM, while Part (b) shows the chip formation in VAM.

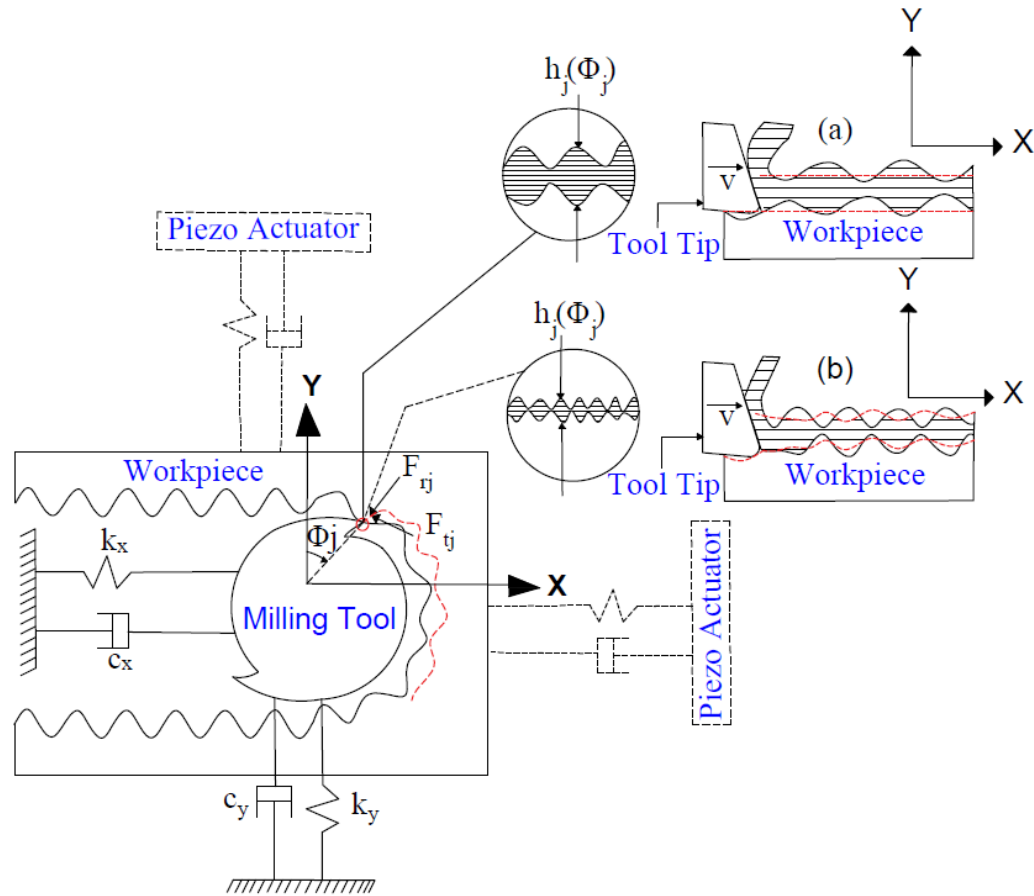

Figure 3.23 Schematic of chip formation in (a) CM and (b) VAM

The dynamics of the milling system are described by the equations of motion:

$$\begin{cases} m_x \ddot{x}_t + c_x \dot{x}_t + k_x x_t = F_x(h_d) \\ m_y \ddot{y}_t + c_y \dot{y}_t + k_y y_t = F_y(h_d) \end{cases} \quad (1)$$

where the dynamic chip thickness  $h_d$  is composed of three parts: the static value  $h_s$ , dynamic value caused by milling tool's vibration  $h_t$ , and the component influenced by assisted vibration applied on the workpiece  $h_w$ , expressed as:

$$h_d = h_s + h_t + h_w \quad (2)$$

where, each component is expressed as:

$$\begin{cases} h_s = c \cdot \sin(\phi_j) \\ h_t = [x_t(t) - x_t(t - T)] \sin \phi_j + [y_t(t) - y_t(t - T)] \cos \phi_j \\ h_w = [x_w(t - T) - x_w(t)] \sin \phi_j + [y_w(t - T) - y_w(t)] \cos \phi_j \end{cases} \quad (3)$$

The tool's vibration  $x_t, y_t$  are determined by the dynamic cutting force obtained in equation (1), while the vibration of workpiece is provided by the piezo-actuator and given as:

$$\begin{cases} x_w(t) = X \sin(\omega t + \varphi_x) \\ y_w(t) = Y \sin(\omega t + \varphi_y) \end{cases} \quad (4)$$

In this experiment, the chatter frequency in conventional milling is 4342 Hz as shown in Figure 3.8. The application of vibration assistance at higher frequency modifies the instantaneous dynamic chip thickness. Since the amplitude of the workpiece vibration is in the same level with the feed rate, the assisted vibration could result into the tool's jumping out of the cutting area, thus the dynamics becomes nonlinear and the regenerative chip formation mechanism completely changes as a result of the vibration assistance. Furthermore, Figure 3.24 shows cutting tool's trajectories relative to the workpiece in two consecutive tooth passing periods in the vibration assisted machining process. It is found that the instantaneous chip thickness could reach very small value at certain cutting

location. Therefore, modification of tool tip trajectory by adding vibration assistance reduces the dynamic cutting force by reducing the dynamic chip thickness.

Moreover, the damping coefficient in the equations of motion (1) is composed of the structural damping as well as the process damping, expressed as:

$$c_{x(y)} = c_{x(y),s} + c_{x(y),p} \quad (5)$$

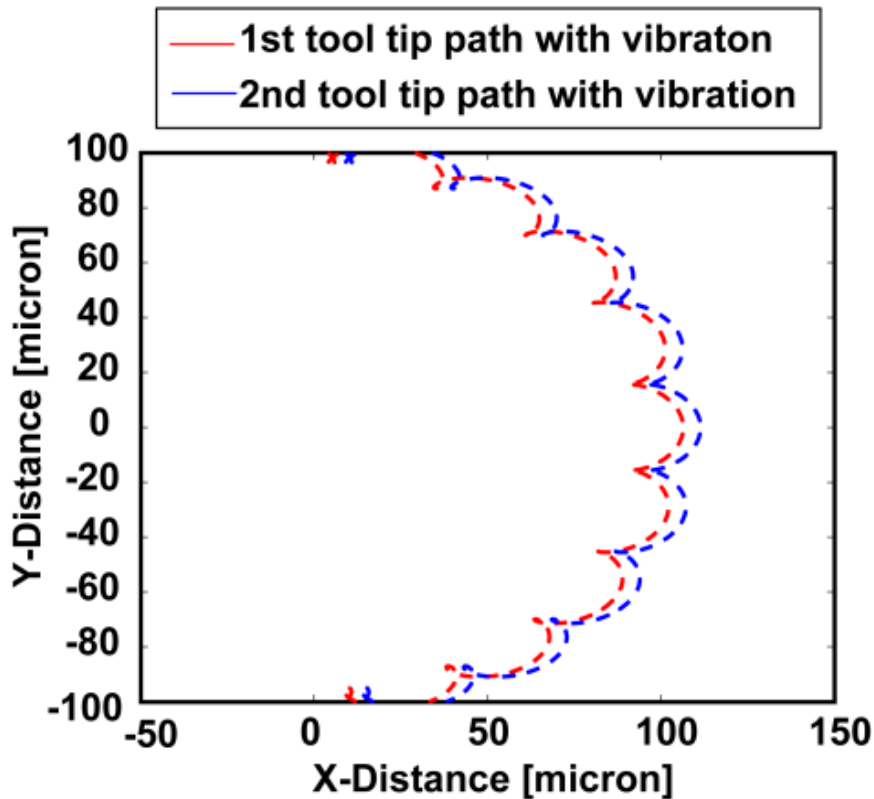

Figure 3.24 Relative cutting tool's trajectory in two consecutive tooth passing periods in

VAM

Shown in Part (b) of Figure 3.23, the contact between the tool's flank face and the work surface contributes to the process damping effect in the machining process. The application of 2-D vibration assistance at higher frequency compared to the original chatter frequency reduces the wavelength of the surface. Since the process damping force is inversely proportional to the wavelength [85], the application of high frequency vibration



assistance decreases the wavelength, therefore increases the process damping force to a certain extent. As a result, the chatter amplitude reduces. However, quantitative analysis requires the calibration of process damping coefficient for Al 6061, and is not in the scope of this experimental study.

## **CHAPTER 4**

### **GENERATION OF SURFACE TEXTURE IN VIBRATION ASSISTED MICRO-MILLING**

#### **4.1 Overview**

This chapter presents the experimental setup and procedures used for generating surface textures in vibration assisted micro milling process. The experimental result, analysis and discussion is also presented here. A 2-fluted squared end carbide tool with helix angle  $30^\circ$  and a 1-fluted diamond tool with  $0^\circ$  helix angle is used to generate the surface textures. Side milling is performed with and without vibration assistance, with different feed rates and the types of tools. The nanovea profilometer and the contact profilometer is used to obtain 3D image of a surface and surface profile respectively.

#### **4.2 Experimental Setup and Procedures**

The experimental set up for generating a surface texture in vibration assisted milling process is similar to the study on chatter vibration, shown in Figure 3.4. The cutting experiments are conducted on MDA precision machining center. Aluminum alloy (AL 6061) workpiece and the tools with 3.125 mm diameter 1-fluted diamond tool with  $0^\circ$  helix angle and 2-fluted carbide tool with  $30^\circ$  helix angle is used.

A workpiece is clamped on the fixture at the center of the vibration stage where the displacement of the piezo-actuator tip is amplified by giving the workpiece a maximum

displacement. At first, the amplitude in feed and normal directions during vibration assistance is measured by the displacement sensor and an accelerometer. The signals from these sensors are sent to MALDAQ in CUTPRO and the amplitudes are measured.

As mentioned in chapter 3, length of the overhang of the tool shank plays an important role in creating instability in the system due to tool vibration during machining. The tool vibration increases with the increase in overhang length of tool shank during machining. Therefore, the overhang length of tool shank is reduced to minimize the tool vibration. Hence, only an external vibration applied on the workpiece plays the dominant role in generating a surface texture. Also, both ends of the workpiece are machined to ensure the flatness and prevent any errors that could be caused by the surface variation during measurement.

The axial and radial depth of cut is chosen to reduce the tool vibration and protect the tool from breakage. A Matlab code as shown in APPENDIX A is developed to study the effect of cutting and vibration parameters on tool tip trajectories which results in surface generation. The spindle speed and feed rate to generate clear surface texture is found through the time domain simulation using the cutting conditions as shown in Table 4.1. The time domain simulation results obtained for conventional and vibration assisted milling is given for each rotation of milling tool as shown in Figure 4.1. The wave formed in conventional milling have a very high aspect ratio of 100 while in vibration assisted machining have only 5. The same cutting conditions as in Table 4.1 is used in an experimental study. The vibration parameters is selected to obtain the maximum displacement of the workpiece. A precut is performed on the workpiece to obtain a flat surface before the real cut. The piezoelectric actuator is tuned on before started machining.

The surface texturing process is performed with determined spindle speed, feedrate and vibration parameters. The machined surface is then scanned using nanovea profilometer. The area to be scanned is chose in such a way that several slots can be seen which clearly shows the surface texture at a particular condition. The area of 1 mm X 0.5 mm is scanned and the resolution is kept to be 1  $\mu\text{m}$  as shown in Figure 4.2. Also, the contact profilometer is also used to measure the surface profile for each samples.

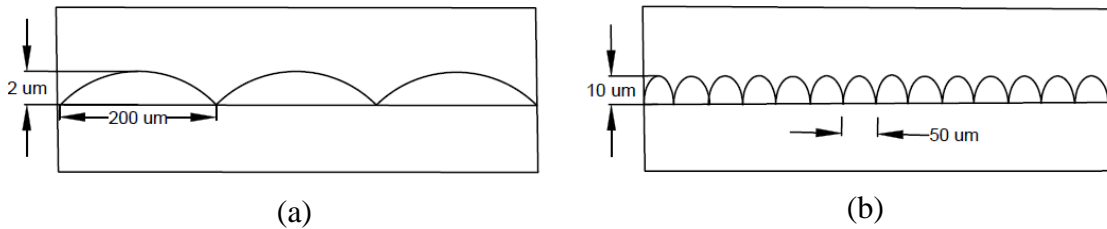

Figure 4.1 Tool tip trajectory using time domain simulation for (a) conventional (b) vibration assisted milling

The milling experiments are performed with and without vibration assistance at the same cutting parameters. Also, vibration assisted cutting is performed at different feed rates with all other cutting and vibration parameters being the same. Each set of cutting experiment is performed by using two types of tools: a 2-fluted carbide tool with  $30^\circ$  helix angle and a 1-fluted diamond tool with  $0^\circ$  helix angle.

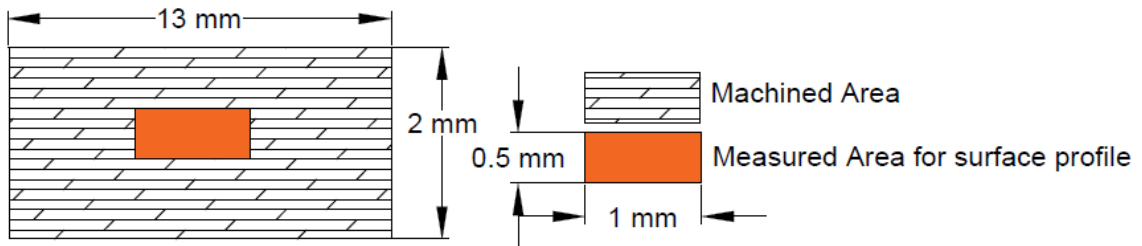

Figure 4.2 Schematic of the area selected for surface measurement using nanovea and contact profilometer

### 4.3 Experimental Results

The milling experiments are performed at AL 6061 workpiece without using any cutting fluids. The machined surface at different cutting conditions is measured by nanovea profilometer. The experimental results of surface profile through the measurement of 1X0.5 mm of machined area is presented. The cutting and vibration parameters used during an experiment is given in Table 4.1.

Table 4.1 Cutting parameters

Vibration Parameters	Frequency (kHz)	8
	Amplitude ( $\mu\text{m}$ )	8.82
Feed Rate ( $\mu\text{m}/\text{flute}$ )		30, 50, 100
Radial Depth of Cut (mm)		0.05
Spindle Speed (rpm)		3000
Axial Depth of Cut (mm)		2

#### 4.3.1 Surface texture in conventional and vibration assisted milling

At first, two different types of tests without and with vibration are performed at feed rate 30  $\mu\text{m}/\text{flute}$ . The tests are then conducted with external vibration applied on a workpiece which greatly influences the surface texture due to the modification of tool tip trajectories. 2D vibration assisted milling experiment is performed to study the effect of vibration on surface texturing. The result in these two cutting condition shows that in conventional cutting the straight lines are formed as shown in Figure 4.3(a). However, sin waves are generated when vibration is applied in 2D as shown in Figure 4.3 (b). The straight lines in Figure 4.3 (b) in some parts of the surface could be due to the inhomogeneity of the material. The aspect ratio of the wave in Figure 4.1 (a) is as high as 100 which makes the appearance of the wave to be a straight line. The vertical lines created on the surface are due to the variation of tool edge profile.

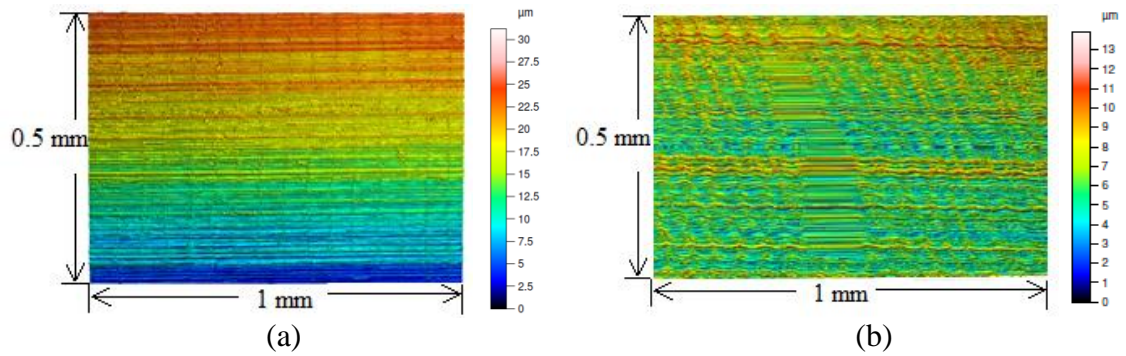

Figure 4.3 Surface texture in (a) conventional (b) vibration cutting with carbide tool.

Similarly, same set of tests for conventional and vibration assisted cutting is performed using 1-fluted diamond tool with  $0^\circ$  helix angle at the same cutting and vibration parameters as shown in Figure 4.4 (a) and (b) respectively. Also, doamond tool generated straight lines in conventional cutting as by carbide tool and wavy texture is generated with the vibration assistance. However, the texture by the diamond tool is denser than by the carbide tool. Also, the wavy structure is distinctly seen in vibration assisted cutting by carbide tool than by the diamond tool. This shows that the helix angle in the tool also may have a positive effect in enhanced wavy structure.

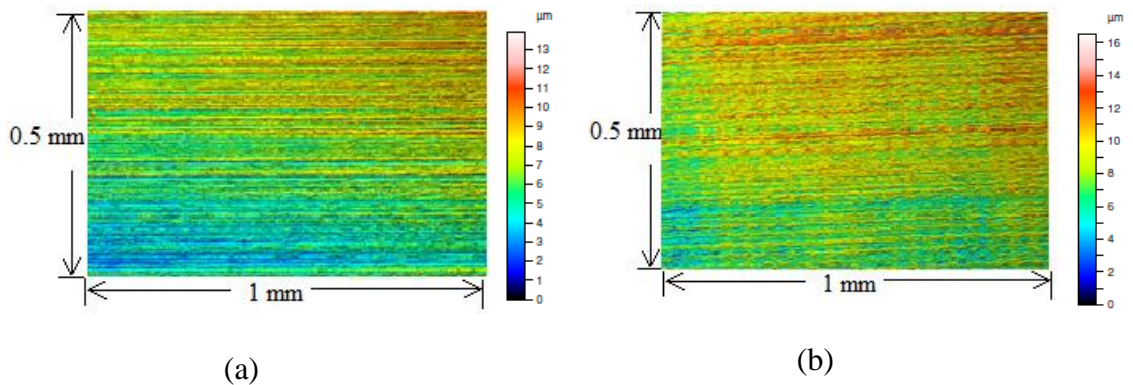

Figure 4.4 Surface texture in (a) conventional (b) vibration cutting with diamond tool

### 4.3.2 Surface Texture with feed rate in vibration assisted milling

Cutting tests are performed at varying feed rates in vibration assisted milling. The surface texture results at feed of rate 30, 50 and 100  $\mu\text{m}/\text{flute}$  is shown in Figure 4.5(a) (b) and (c) respectively. The waves are more defined and smaller in size at lower feed rate and the length of the waves increases with the increase in feed rate.. However, higher feed rate resulted in surface damage. This could be due to the increase in cutting force.

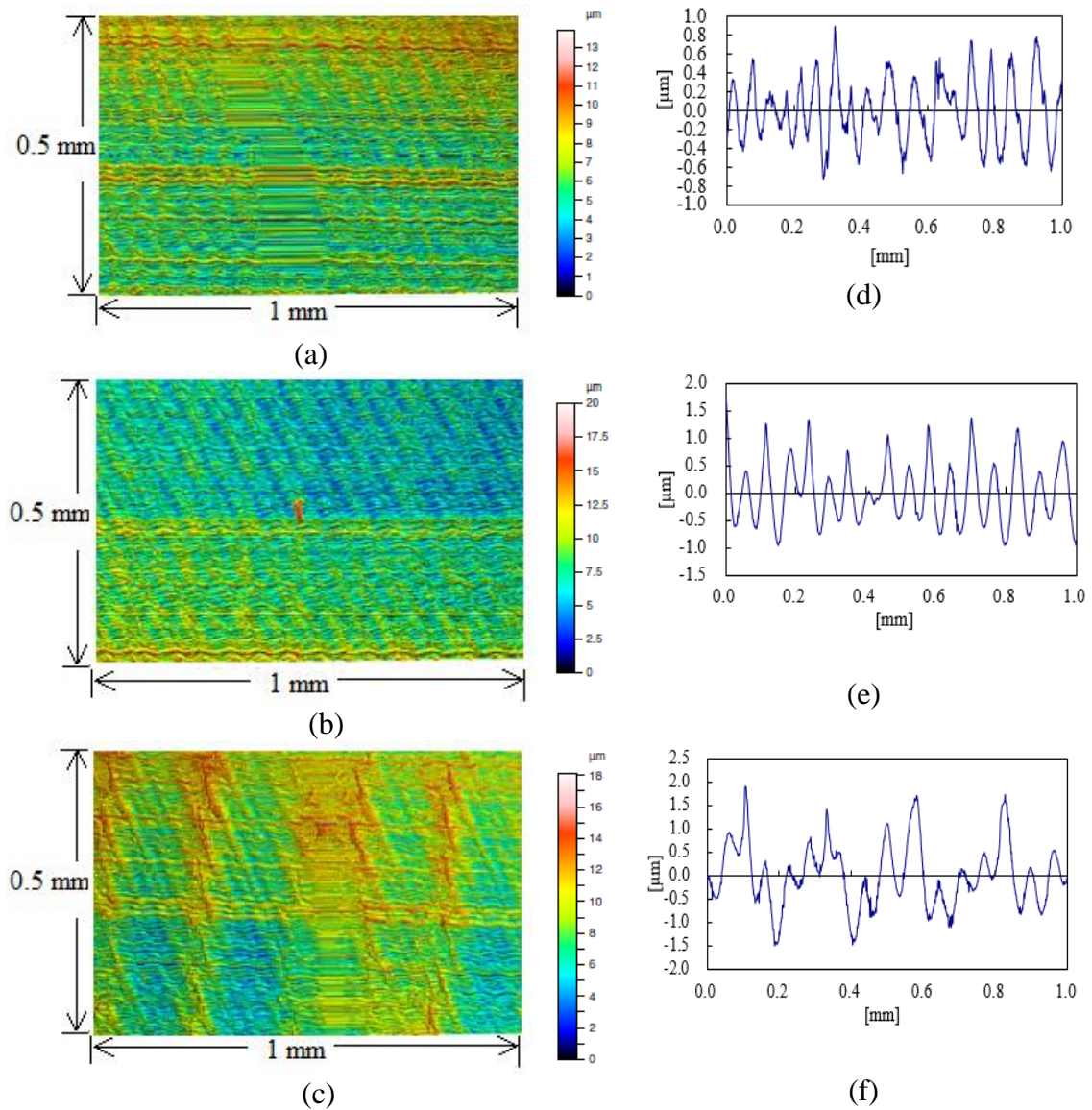

Figure 4.5 Surface texture and profiles at (a)(d) 30  $\mu\text{m}/\text{flute}$ , (b)(e) 50  $\mu\text{m}/\text{flute}$  (c)(f) 100  $\mu\text{m}/\text{flute}$  using carbide tool

Similar experiments are performed in vibration assisted cutting at varying feed rates using one-fluted diamond tool. The surface texture and profile results at feed rate 30, 50 and 100  $\mu\text{m}/\text{flute}$  is shown in Figure 4.6 (a), (b) and (c) and in Figure 4.6 (d), (e) and (f) respectively. At the same cutting conditions the surface damage by the diamond tool is lower than by carbide tool.

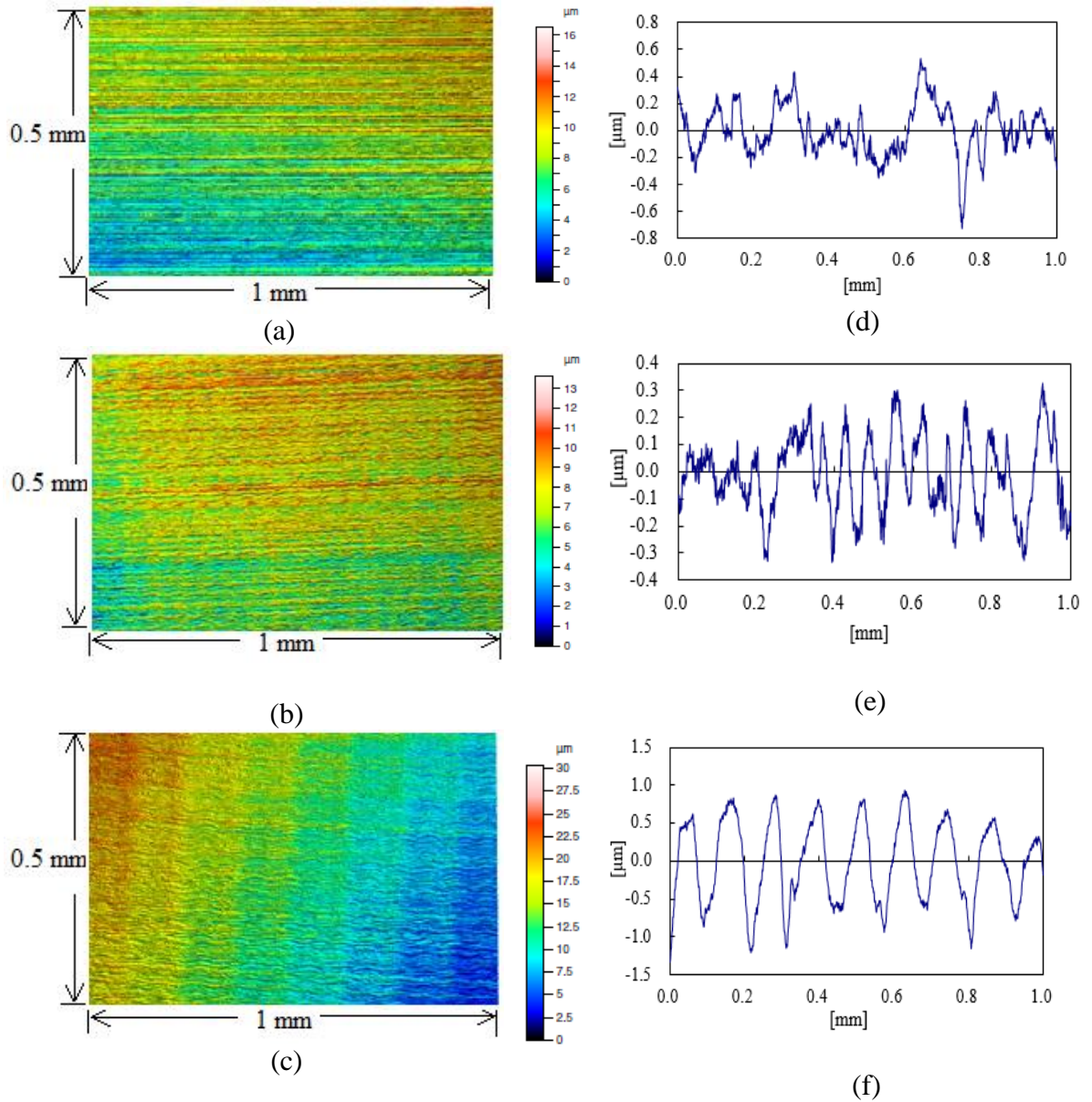

Figure 4.6 Surface texture and profiles at (a)(d) 30  $\mu\text{m}/\text{flute}$ , (b)(e) 50  $\mu\text{m}/\text{flute}$  (c)(f) 100  $\mu\text{m}/\text{flute}$  using diamond tool



#### **4.4 Analysis and Discussion of Vibration Assistance on Surface Texturing**

A wavy surface texture can be generated with the vibration assistance in two directions. In this experiment the input sinusoidal waveform was given which resulted in sin waves on the surface texture. Hence, sinusoidal, triangular, squared, saw toothed and pulse-like waves can be generated on the surface depending upon the input commands. Also, the waviness of the surface texture can be changed with the change in vibration amplitude in the normal direction where waviness increases with the increase in amplitude.

The tool material and geometry is another important factor that affects the surface texture. Due to the superior material properties of diamond, the surface texture with diamond tool gives defined and denser waves. Also, the tool edge marks left by the diamond tool is less intense than by carbide tool. Hence, diamond tool prevents from deteriorating the surface texture quality. The higher waviness in the surface texture with the carbide tool compared to the diamond tool could be the result of  $30^\circ$  and  $0^\circ$  helix angle respectively.

The feed rate during cutting determines the length of the waves in the horizontal direction. When the feed rate is small, the waves begin to overlap which makes the waves shorter. In such case the feed rate can be selected based on the shape requirement of the waves. However, the surface damage increases with the increase in feed rate and is more severe using carbide tool than the diamond tool.

The measured surfaces in every conditions show the non-periodic profiles. This could be due to the forced vibration tool-runout, tool vibration and inhomogeneity of the material.

## CHAPTER 5

### CONCLUSIONS AND RECOMMENDATIONS

#### 5.1 Conclusion

This thesis presents the experimental study on the chatter attenuation in vibration assisted micro-milling of Al 6061 and surface texture generation. A 2-D vibration stage driven by piezoelectric actuators and flexure design is used. In the study of chatter vibration, experimental modal test is conducted on the milling tool, and the cutting conditions are selected to intentionally have chatter. The chatter signal is measured by microphone, and the chatter amplitudes corresponding to with and without vibration assistance are compared and analyzed. The following conclusions are drawn based on this study:

(1) The developed vibration stage is able to generate 2-D vibration on the workpiece in the frequency range of 5-10 kHz with the amplitude of 1-10  $\mu\text{m}$ , which is comparable to the typical feed rate values in micro milling process. Therefore, the assisted vibration significantly influences the dynamic chip thickness in the milling process.

(2) The experimental results demonstrate that the average chatter amplitude is attenuated by 20% - 33% when vibration assistance is provided in 1-D in a series of frequencies and amplitudes, while the chatter amplitude reduces by up to 44% when the vibration assistance is provided in 2-D. It is because the applied vibration modifies the dynamic thickness therefore changes the regenerative mechanism in the chip formation. Furthermore, higher

frequency of applied vibration compared to the chatter vibration causes more process damping effect. The chatter amplitude decreases as a result.

(3) The experimental results show that the applied vibration assistance attenuates regenerative chatter in a range of feed rate values, with which the relationship between the force and the chip thickness becomes nonlinear in the micro milling process. This experimental study demonstrates that the 2-D vibration assistance is able to effectively attenuate the high frequency regenerative chatter in the micro milling process.

Also a novel technique is developed to create the surface texture through vibration assistance on the micro-milling process. This machining process is easy to implement using a piezo-electric actuator to create a wavy structure of varying sizes based on the vibration amplitude, tool material, tool geometry and the feed rate. From the surface texture experiments following conclusions are drawn:

(1) The wavy structure can be generated with the vibration assistance at certain vibration frequency and amplitude. The type of the wave generated can be sinusoidal, triangular or pulse-like depending upon the input signal from the signal generator.

(2) The wave generated by the diamond tool is more defined than by the carbide tool. The carbide tool tend to leave more distinct tool edge marks on the surface hence reduce the quality of the surface texture than the diamond tool.

(3) The feed rate changes the shape of the waves in the horizontal direction. The longer waves can be generated with higher feed rate and shorter with the lower feed rate. When the feed rate is lower the waves begin to overlap and hence appears shorter. From the experimental results it is also concluded that the surface damage increases with the

increase in feed rate using carbide tool. While the surface damage is lower at the same feed rate using a diamond tool.

## **5.2 Recommendations for future work**

The accuracy of an analytical solution of stability lobes depends upon the cutting force coefficients of the workpiece. Measurement of cutting force using a force sensor and calculation of cutting force coefficients would result in accurate stable depth of cut in theoretical solution for conventional milling. The theoretical solution can be verified experimentally. This also can be utilized to know the approximate stable depth of cut for vibration assisted milling.

The chatter reduction rate can be increased by applying vibration frequency in ultrasonic range. An ultrasonic frequency reduces the tool workpiece contact ratio which creates an easy chip flow. Also, the high frequency tool tip trajectory causes the chip breakage resulting in smaller chip formation and reduction in chatter amplitude.

The surface texturing technique can be extended by using ball end mills which can create dimples along the surface. Such dimpled surfaces can be used as a hydrophobic material and also can be used in micro heat exchange.

The effect of phase differences between the vibrations applied in two directions can be studied in surface texturing. The phase difference decides the vibration motion of a workpiece. Different type of surface textures can be generated with varying shapes in such case. However, the higher vibration amplitude would give a more distinct result.

## REFERENCES

- [1]. Quintana, G.J. Ciurana, Chatter in machining processes: A review. *International Journal of Machine Tools and Manufacture*, 2011. 51(5), 363-376.
- [2]. Rashwan, O., Micro surface texturing for friction control. 2013, University of Windsor.
- [3]. Moradi, H., G. Vossoughi, M. Behzad, and M.R. Movahhedy, Vibration absorber design to suppress regenerative chatter in nonlinear milling process: Application for machining of cantilever plates. *Applied Mathematical Modelling*, 2015. 39(2), 600-620.
- [4]. Madoliat, R., S. Hayati, and A.G. Ghalebahman, Investigation of chatter suppression in slender endmill via a frictional damper. *Scientia Iranica*, 2011. 18(5), 1069-1077.
- [5]. Wang, M., Feasibility study of nonlinear tuned mass damper for machining chatter suppression. *Journal of Sound and Vibration*, 2011. 330(9), 1917-1930.
- [6]. Tomasz Kucharski, K.K., An experimental detection and suppression of chatter vibration in modern milling machines. 2012.
- [7]. Lin, S.C.M.R. Hu, Low vibration control system in turning. *International Journal of Machine Tools and Manufacture*, 1992. 32(5), 629-640.
- [8]. Mei, Z., S. Yang, H. Shi, S. Chang, Active chatter suppression by on-line variation of the rake and clearance angles in turning— principles and experimental investigations. *International Journal of Machine Tools and Manufacture*, 1994. 34(7), 981-990.
- [9]. Frumusanu, G., I. Constantin, V. Marinescu, and A. Epureanu, Development of a stability intelligent control system for turning. *The International Journal of Advanced Manufacturing Technology*, 2013. 64(5-8), 643-657.
- [10]. Jin, X.L.Y. Altintas, Chatter stability model of micro-milling with process damping. *Journal of Manufacturing Science and Engineering-Transactions of the Asme*, 2013. 135(3), 031011-031011.
- [11]. Guo, P.K.F. Ehmann, Development of a tertiary motion generator for elliptical vibration texturing. *Precision Engineering*, 2013. 37(2), 364-371.
- [12]. Brehl, D.E.T.A. Dow, Review of vibration-assisted machining. *Precision Engineering*, 2008. 32(3), 153-172.
- [13]. Shen, X.-H., J.-H. Zhang, H. Li, J.-J. Wang, Ultrasonic vibration-assisted milling of aluminum alloy. *The International Journal of Advanced Manufacturing Technology*, 2012. 63(1-4), 41-49.
- [14]. Xiao, M., K. Sato, S. Karube, and T. Soutome, The effect of tool nose radius in ultrasonic vibration cutting of hard metal. *International Journal of Machine Tools and Manufacture*, 2003. 43(13), 1375-1382.

- [15]. Zhou, M., Y.T. Eow, B.K.A. Ngoi, and E.N. Lim, Vibration-assisted precision machining of steel with pcd tools. *Materials and Manufacturing Processes*, 2003. 18(5), 825-834.
- [16]. Weber, H., J. Herberger, and R. Pilz, Turning of machinable glass ceramics with an ultrasonically vibrated tool. *CIRP Annals - Manufacturing Technology*, 1984. 33(1), 85-87.
- [17]. Ma, C., E. Shamoto, T. Moriwaki, Y. Zhang, Suppression of burrs in turning with ultrasonic elliptical vibration cutting. *International Journal of Machine Tools and Manufacture*, 2005. 45(11), 1295-1300.
- [18]. Shamoto, E., C. Ma, and T. Moriwaki, Ultraprecision ductile cutting of glass by applying ultrasonic elliptical vibration cutting. *Precision engineering nanotechnology*, 1999. 1, 408-411.
- [19]. Shamoto, E.T. Moriwaki, Study on elliptical vibration cutting. *CIRP Annals - Manufacturing Technology*, 1994. 43(1), 35-38.
- [20]. Suzuki, N., A. Nakamura, E. Shamoto, K. Harada. Ultraprecision micromachining of hardened steel by applying ultrasonic elliptical vibration cutting. in *Micromechatronics and Human Science*, 2003. MHS 2003. Proceedings of 2003 International Symposium on. 2003.
- [21]. Nath, C., M. Rahman, and K.S. Neo, Machinability study of tungsten carbide using pcd tools under ultrasonic elliptical vibration cutting. *International Journal of Machine Tools and Manufacture*, 2009. 49(14), 1089-1095.
- [22]. Mitrofanov, A., N. Ahmed, V. Babitsky, and V. Silberschmidt, Effect of lubrication and cutting parameters on ultrasonically assisted turning of inconel 718. *Journal of materials processing technology*, 2005. 162, 649-654.
- [23]. Skelton, R., Effect of ultrasonic vibration on the turning process. *International Journal of Machine Tool Design and Research*, 1969. 9(4), 363-374.
- [24]. Mitrofanov, A.V., V.I. Babitsky, and V.V. Silberschmidt, Finite element simulations of ultrasonically assisted turning. *Computational Materials Science*, 2003. 28(3-4), 645-653.
- [25]. Zhang, Y.L., Z.M. Zhou, and Z.H. Zia, Diamond turning of titanium alloy by applying ultrasonic vibration. *TRANSACTIONS OF NONFERROUS METALS SOCIETY OF CHINA*, 2005. 15, 279-282.
- [26]. Nath, C.M. Rahman, Effect of machining parameters in ultrasonic vibration cutting. *International Journal of Machine Tools and Manufacture*, 2008. 48(9), 965-974.
- [27]. Xiao, M., S. Karube, T. Soutome, and K. Sato, Analysis of chatter suppression in vibration cutting. *International Journal of Machine Tools and Manufacture*, 2002. 42(15), 1677-1685.
- [28]. Xiao, M., Q.M. Wang, K. Sato, S. Karube, The effect of tool geometry on regenerative instability in ultrasonic vibration cutting. *International Journal of Machine Tools and Manufacture*, 2006. 46(5), 492-499.
- [29]. Chern, G.-L.Y.-C. Chang, Using two-dimensional vibration cutting for micro-milling. *International Journal of Machine Tools and Manufacture*, 2006. 46(6), 659-666.
- [30]. Ding, H., R. Ibrahim, K. Cheng, and S.-J. Chen, Experimental study on machinability improvement of hardened tool steel using two dimensional vibration-

- assisted micro-end-milling. *International Journal of Machine Tools and Manufacture*, 2010. 50(12), 1115-1118.
- [31]. Zarchi, M.M.A., M.R. Razfar, and A. Abdullah, Investigation of the effect of cutting speed and vibration amplitude on cutting forces in ultrasonic-assisted milling. *PROCEEDINGS OF THE INSTITUTION OF MECHANICAL ENGINEERS PART B-JOURNAL OF ENGINEERING MANUFACTURE*, 2012. 226(B7), 1185-1191.
- [32]. Abootorabi Zarchi, M.M., M.R. Razfar, and A. Abdullah, Influence of ultrasonic vibrations on side milling of aisi 420 stainless steel. *The International Journal of Advanced Manufacturing Technology*, 2013. 66(1-4), 83-89.
- [33]. Hsu, C.Y., C.K. Huang, and C.Y. Wu, Milling of mar-m247 nickel-based superalloy with high temperature and ultrasonic aiding. *The International Journal of Advanced Manufacturing Technology*, 2007. 34(9-10), 857-866.
- [34]. Li, K.-M.S.-L. Wang, Effect of tool wear in ultrasonic vibration-assisted micro-milling. *Proceedings of the Institution of Mechanical Engineers, Part B: Journal of Engineering Manufacture*, 2014. 228(6), 847-855.
- [35]. Shen, X.-H., J. Zhang, D. Xing, and Y. Zhao, A study of surface roughness variation in ultrasonic vibration-assisted milling. *The International Journal of Advanced Manufacturing Technology*, 2012. 58(5-8), 553-561.
- [36]. Altintas, Y., *Manufacturing automation: Metal cutting mechanics, machine tool vibrations, and cnc design*. 2012: Cambridge university press.
- [37]. Tobias, S.W. Fishwick, Theory of regenerative machine tool chatter. *The engineer*, 1958. 205(7), 199-203.
- [38]. Tlusty, J.M. Polacek, The stability of machine tools against self-excited vibrations in machining. *International research in production engineering*, 1963. 1(1), 465-474.
- [39]. Campomanes, M.L., *Dynamics of milling flexible structures*. 1998, University of British Columbia.
- [40]. Delio, T., J. Tlusty, and S. Smith, Use of audio signals for chatter detection and control. *JOURNAL OF ENGINEERING FOR INDUSTRY-TRANSACTIONS OF THE ASME*, 1992. 114(2), 146-157.
- [41]. Kim, N.H., D. Won, and J.C. Ziegert, Numerical analysis and parameter study of a mechanical damper for use in long slender endmills. *International Journal of Machine Tools and Manufacture*, 2006. 46(5), 500-507.
- [42]. Semercigil, S.E.L.A. Chen, Preliminary computations for chatter control in end milling. *Journal of Sound and Vibration*, 2002. 249(3), 622-633.
- [43]. Miguélez, M.H., L. Rubio, J.A. Loya, and J. Fernández-Sáez, Improvement of chatter stability in boring operations with passive vibration absorbers. *International Journal of Mechanical Sciences*, 2010. 52(10), 1376-1384.
- [44]. Wang, J.H.K.N. Lee, Suppression of chatter vibration of a cnc machine centre—an example. *Mechanical Systems and Signal Processing*, 1996. 10(5), 551-560.
- [45]. Yusoff, A., S. Turner, C. Taylor, and N. Sims, The role of tool geometry in process damped milling. *The International Journal of Advanced Manufacturing Technology*, 2010. 50(9-12), 883-895.

- [46]. Marui, E., S. Ema, M. Hashimoto, and Y. Wakasawa, Plate insertion as a means to improve the damping capacity of a cutting tool system. *International Journal of Machine Tools and Manufacture*, 1998. 38(10–11), 1209-1220.
- [47]. De Lacalle, N.L.A.L. Mentxaka, *Machine tools for high performance machining*. 2008: Springer Science & Business Media.
- [48]. Sims, N.D., B. Mann, and S. Huyanan, Analytical prediction of chatter stability for variable pitch and variable helix milling tools. *Journal of Sound and Vibration*, 2008. 317(3–5), 664-686.
- [49]. Budak, E., An analytical design method for milling cutters with nonconstant pitch to increase stability, part i: Theory. *Journal of Manufacturing Science and Engineering*, 2003. 125(1), 29-34.
- [50]. Ma, C., J. Ma, E. Shamoto, and T. Moriwaki, Analysis of regenerative chatter suppression with adding the ultrasonic elliptical vibration on the cutting tool. *Precision Engineering*, 2011. 35(2), 329-338.
- [51]. Tabatabaei, S.M.K., S. Behbahani, and S.M. Mirian, Analysis of ultrasonic assisted machining (uam) on regenerative chatter in turning. *Journal of Materials Processing Technology*, 2013. 213(3), 418-425.
- [52]. Yao, Z., D. Mei, and Z. Chen, Chatter suppression by parametric excitation: Model and experiments. *Journal of Sound and Vibration*, 2011. 330(13), 2995-3005.
- [53]. Wang, M., T. Zan, Y. Yang, and R. Fei, Design and implementation of nonlinear tmd for chatter suppression: An application in turning processes. *International Journal of Machine Tools and Manufacture*, 2010. 50(5), 474-479.
- [54]. Rivin, E.I.H. Kang, Improvement of machining conditions for slender parts by tuned dynamic stiffness of tool. *International Journal of Machine Tools and Manufacture*, 1989. 29(3), 361-376.
- [55]. Olgac, N.M. Hosek, A new perspective and analysis for regenerative machine tool chatter. *International Journal of Machine Tools and Manufacture*, 1998. 38(7), 783-798.
- [56]. Olgac, N.B.T. Holm-Hansen, A novel active vibration absorption technique: Delayed resonator. *Journal of Sound and Vibration*, 1994. 176(1), 93-104.
- [57]. Takemura, T., T. Kitamura, T. Hoshi, and K. Okushima, Active suppression of chatter by programmed variation of spindle speed. *Annals of the CIRP*, 1974. 23(1), 121-122.
- [58]. Al-Regib, E., J. Ni, and S.-H. Lee, Programming spindle speed variation for machine tool chatter suppression. *International Journal of Machine Tools and Manufacture*, 2003. 43(12), 1229-1240.
- [59]. Inamura, T.T. Sata, Stability analysis of cutting under varying spindle speed. *Journal of the Japan Society of Precision Engineering*, 1977. 43(505), 80-85.
- [60]. Lin, S.C., R.E. DeVor, and S.G. Kapoor, The effects of variable speed cutting on vibration control in face milling. *Journal of Manufacturing Science and Engineering*, 1990. 112(1), 1-11.
- [61]. Cao, H., B. Li, and Z. He, Chatter stability of milling with speed-varying dynamics of spindles. *International Journal of Machine Tools and Manufacture*, 2012. 52(1), 50-58.
- [62]. Zatarain, M., I. Bediaga, J. Muñoa, and R. Lizarralde, Stability of milling processes with continuous spindle speed variation: Analysis in the frequency and time



- domains, and experimental correlation. *CIRP Annals - Manufacturing Technology*, 2008. 57(1), 379-384.
- [63]. Bediaga, I., J. Muñoa, J. Hernández, and L.N. López de Lacalle, An automatic spindle speed selection strategy to obtain stability in high-speed milling. *International Journal of Machine Tools and Manufacture*, 2009. 49(5), 384-394.
- [64]. Slavicek, J. The effect of irregular tooth pitch on stability of milling. in *Proceedings of the 6th MTDR Conference*. 1965.
- [65]. Budak, E., An analytical design method for milling cutters with nonconstant pitch to increase stability, part i: Theory. *TRANSACTIONS-AMERICAN SOCIETY OF MECHANICAL ENGINEERS JOURNAL OF MANUFACTURING SCIENCE AND ENGINEERING*, 2003. 125(1), 29-34.
- [66]. Tewani, S.G., K.E. Rouch, and B.L. Walcott, A study of cutting process stability of a boring bar with active dynamic absorber. *International Journal of Machine Tools and Manufacture*, 1995. 35(1), 91-108.
- [67]. Mei, C., Active regenerative chatter suppression during boring manufacturing process. *Robotics and Computer-Integrated Manufacturing*, 2005. 21(2), 153-158.
- [68]. Siddhpura, M.R. Paurobally, A review of chatter vibration research in turning. *International Journal of Machine Tools and Manufacture*, 2012. 61(0), 27-47.
- [69]. Brecher, C., D. Manoharan, U. Ladra, and H.G. Köpken, Chatter suppression with an active workpiece holder. *Production Engineering*, 2010. 4(2-3), 239-245.
- [70]. Mei, D., T. Kong, A.J. Shih, and Z. Chen, Magnetorheological fluid-controlled boring bar for chatter suppression. *Journal of Materials Processing Technology*, 2009. 209(4), 1861-1870.
- [71]. Choudhury, S.K., N.N. Goudimenko, and V.A. Kudinov, On-line control of machine tool vibration in turning. *International Journal of Machine Tools and Manufacture*, 1997. 37(6), 801-811.
- [72]. Soliman, E.F. Ismail, Chatter suppression by adaptive speed modulation. *International Journal of Machine Tools and Manufacture*, 1997. 37(3), 355-369.
- [73]. Kubica, E.G.F. Ismail, Active suppression of chatter in peripheral milling. Part ii. Application of fuzzy control. *The International Journal of Advanced Manufacturing Technology*, 1996. 12(4), 236-245.
- [74]. Rashid, A.C. Mihai Nicolescu, Active vibration control in palletised workholding system for milling. *International Journal of Machine Tools and Manufacture*, 2006. 46(12-13), 1626-1636.
- [75]. Kaliński, K.J., M. Chodnicki, M.R. Mazur, and M.A. Galewski, Vibration surveillance system with variable stiffness holder for milling flexible details, in *Applied non-linear dynamical systems*. 2014, Springer. 175-184.
- [76]. Parus, A., B. Powalka, K. Marchelek, S. Domek, Active vibration control in milling flexible workpieces. *Journal of Vibration and Control*, 2012. 19(7), 1103-1120.
- [77]. Guo, P.K.F. Ehmann, An analysis of the surface generation mechanics of the elliptical vibration texturing process. *International Journal of Machine Tools and Manufacture*, 2013. 64(0), 85-95.
- [78]. Guo, P., Y. Lu, P. Pei, and K.F. Ehmann, Fast generation of micro-channels on cylindrical surfaces by elliptical vibration texturing. *Journal of Manufacturing Science and Engineering*, 2014. 136(4), 041008-041008.

- [79]. Guo, P., Y. Lu, K.F. Ehmann, and J. Cao, Generation of hierarchical micro-structures for anisotropic wetting by elliptical vibration cutting. *CIRP Annals - Manufacturing Technology*, 2014. 63(1), 553-556.
- [80]. Subbiah, S., S.H. Yeo, A.S. Adnan, and J.H. Ko, Microtexture generation using controlled chatter machining in ultraprecision diamond turning. 2014.
- [81]. Suzuki, H., M. Marshall, N. Sims, and R. Dwyer-Joyce, Surface texturing by vibration assisted machining with piezoelectric actuator. 2014.
- [82]. Yan, J., Z. Zhang, T. Kuriyagawa, and H. Gonda, Fabricating micro-structured surface by using single-crystalline diamond endmill. *The International Journal of Advanced Manufacturing Technology*, 2010. 51(9-12), 957-964.
- [83]. CUTPRO™ Fundamentals of machining, start to finish guide. 2013.
- [84]. CUTPRO™. Advanced milling process simulation system. 2013, Available from: [www.malinc.com](http://www.malinc.com).
- [85]. Altintas, Y.X. Jin, Mechanics of micro-milling with round edge tools. *CIRP Annals - Manufacturing Technology*, 2011. 60(1), 77-80.

## APPENDIX A

### TIME DOMAIN SIMULATION FOR THE TOOL TIP TRAJECTORIES WITH EACH ROTATION OF THE TOOL

```
clc; clear all; close all;
N = 3000;      % RPM
feedrate =100; % um/flute
D = 3.125*1000; % Diameter
r = D/2;      % Radius
omega = 2*pi*N/60; % rad/sec
feedspeed = feedrate*N/60; % um/second

feedspeed_mm_min = feedspeed/1000*60;

%% workpiece vibration
omega_work = 8000*2*pi; % rad
X_work_amp = 8;
Y_work_amp = 8;
phai = 90; % Relative Phase between workpiece and tool's motion

phai_difference = 90/180*pi; % rad phase difference between X and Y
axes of workpiece

%% Time domain simulation
% Trajectory in first rotation
time_rot_1 = 60/N; % [sec]
time_vec_rot_1 = 0:time_rot_1/20000:time_rot_1;
theta_rad = time_vec_rot_1*omega;

x_work_rot1 = X_work_amp * sin(omega_work*time_vec_rot_1 + phai);
y_work_rot1 = Y_work_amp * sin(omega_work*time_vec_rot_1 + phai +
phai_difference);
x_tool_rot1 = r*sin(theta_rad)+feedspeed*time_vec_rot_1;
y_tool_rot1 = r*cos(theta_rad);
x_rot1 = x_tool_rot1 - x_work_rot1;
y_rot1 = y_tool_rot1 - y_work_rot1;

% Trajectory in second rotation
time_vec_rot_2 = time_vec_rot_1 + time_rot_1;
x_work_rot2 = X_work_amp * sin(omega_work*time_vec_rot_2 + phai);
y_work_rot2 = Y_work_amp * sin(omega_work*time_vec_rot_2 + phai +
phai_difference);
```

```

x_tool_rot2 = r*sin(theta_rad)+feedspeed*time_vec_rot_2;
y_tool_rot2 = r*cos(theta_rad);
x_rot2 = x_tool_rot2 - x_work_rot2;
y_rot2 = y_tool_rot2 - y_work_rot2;

% Trajectory in second rotation
time_vec_rot_3 = time_vec_rot_2 + time_rot_1;
x_work_rot3 = X_work_amp * sin(omega_work*time_vec_rot_3 + phai);
y_work_rot3 = Y_work_amp * sin(omega_work*time_vec_rot_3 + phai +
phai_difference);
x_tool_rot3 = r*sin(theta_rad)+feedspeed*time_vec_rot_3;
y_tool_rot3 = r*cos(theta_rad);
x_rot3 = x_tool_rot3 - x_work_rot3;
y_rot3 = y_tool_rot3 - y_work_rot3;

figure(1)
plot(x_tool_rot1,y_tool_rot1,'b',x_tool_rot2,y_tool_rot2,'r',x_tool_rot
3,y_tool_rot3,'k')
xlabel('X-Cord [\mum]')
ylabel('Y-Cord [\mum]')
% xlim([0 5])
% ylim([r-0.01 r])
legend('Traj1-wo-vib','Traj2-wo-vib','Traj3-wo-vib')

figure(2)
plot(x_rot1,y_rot1,'b',x_rot2,y_rot2,'r',x_rot3,y_rot3,'k')
xlabel('X-Cord [\mum]')
ylabel('Y-Cord [\mum]')
% xlim([0 5])
% ylim([r-0.01 r])
legend('Traj1-w-vib','Traj2-w-vib','Traj3-w-vib')

```

VITA

ANJU POUDEL

Candidate for the Degree of

Master of Science

Thesis: INVESTIGATION ON THE CHATTER VIBRATION AND SURFACE  
TEXTURE IN VIBRATION ASSISTED MICRO-MILLING PROCESS

Major Field: MECHANICAL ENGINEERING

Biographical:

Education:

Completed the requirements for the Masters of Science in Mechanical Engineering at Oklahoma State University, Stillwater, Oklahoma in July, 2015

Completed the requirements for the Bachelor of Science in Mechanical Engineering at University of New Orleans, New Orleans, Louisiana in May 2013

Experience:

Graduate Research Assistant at Oklahoma State University, Stillwater, Oklahoma (Jan 2014 to Present)

Graduate Teaching Assistant at Oklahoma State University, Stillwater, Oklahoma (Aug 2013- May 2015)