

REAL TIME DATA ANALYTICS AS APPLIED TO WEB-TO-ROLLER TRACTION IN MANUFACTURING

By

**K. A. Cole¹, R. W. Hopkins², N. A. Hotto¹, J. J. Scheible³,
B. J. Schneider¹, and T. J. White¹**

¹Optimation Technology, Inc, Rochester, NY

²Eastman Kodak Co, Rochester, NY

³MVE Analytics, LLC, Fairport, NY

USA

ABSTRACT

Avoidance of web handling-related imperfections is often a challenge. As an example, the limit of web-to-roller traction is typically not detected until it is exceeded, resulting in product damage. Detection is often made through product inspection. This delay can result in a large volume of unacceptable material being produced. Inclusion of roller speed monitoring can greatly improve response time, but detection still takes place after failure has occurred.

Avoidance of traction problems is normally approached by providing robust equipment design, although this ability is often limited by other machine layout limitations. Variables that can influence web-to-roller traction include: roller wrap angle, roller surface roughness, web surface roughness, bearing frictional drag, roller venting, boundary layer air volume, track-off of foreign materials onto roller surfaces, and wear of roller surfaces.

Measurement of web-to-roller traction, often described as excess traction, requires a pre-determined amount of torque to be applied to the roller until the onset of slip. This paper describes an approach which incorporates one or more remote-actuated, machine-mounted prony brakes and a process monitoring (PM) system, which would permit rapid measurement of excess traction on a routinely-scheduled basis while running non-saleable material, enabling traction performance to be trended, and anticipating failures before they occur on saleable product.

Incorporating targeted measurement data into a PM system will permit calculations and comparative controls to alarm when there is evidence of traction deterioration. This system provides machine learning algorithms to predict process deterioration and provide input to preventative maintenance scheduling.

NOMENCLATURE

cDAQ – Compact Data Acquisition
COT – Coefficient of Traction
HMI – Human Machine Interface
FFT – Fast Fourier Transform
OPC – Open Platform Communication
PLC – Programmable Logic Controller
 T_H – High side total tension (lb)
 T_L – Low side total tension (lb)
TWR – Thin Web Rewinder
UA – Unified Architecture
 θ – Web wrap angle (rad)

INTRODUCTION

Maintaining adequate web-to-roller traction is a common challenge in web handling. Web-to-roller traction, in this context, is normally defined as excess traction, or the traction above that which is required to overcome frictional forces associated with the roller. It could be thought of as “headroom” in the process.

Appropriate equipment design for robust traction is the common approach to minimizing problems, but web handling performance is rarely the top priority when designing production equipment. A partial list of variables that can influence web-to-roller traction and may be out of the control of the production operation includes:

- Wrap angle
- Roller diameter
- Roller surface roughness
- Web surface roughness
- Web planarity
- Roller venting
- Roller surface wear
- Web-to-roller static coefficient of friction
- Contamination of roller surface (dirt, track-off from web)
- Bearing drag
- Machine speed
- Web tension
- Web tension variation
- Process temperature
- External noise/vibration

The most common means of detecting web-to-roller slip is through product inspection. Presence of scratches, whether solid or repeating broken scratches, due to a slow-turning but not stationary roller, implies product waste and loss of efficiency. The method by which the scratches are identified, such as a surface scanner or manual

examination of a product roll, determines the amount of waste generated before the problem can be corrected.

Previous work has been done to reduce the time required to identify roller slip, including speed monitoring of multiple process rollers, generally in areas where the process requirements have led to marginal traction, even under optimum conditions. An example of this was presented in 1997 by A. R. Bentz of Eastman Kodak Co [1]. While reducing response time, this still did not achieve the ultimate goal of anticipating problems before they occurred.

Following a maintenance shutdown, or on startup of particularly scratch-prone products, it is common practice to run a “scratch test”. As the name implies, this is done by running a small amount of the material in question, then shutting down for off-line inspection. This, however, is still a pass-fail determination. It does not indicate how close to slip process rollers are – in other words, how much “headroom” there is in the web/roller system. If there is enough concern, a hand-held prony brake could be used to quantify the amount of excess traction, but this test is often impractical, due to insufficient machine access, and is always undesirable from a safety perspective.

This paper describes a concept that involves one or more machine-mounted prony brakes, in locations that are highly prone to slip. During a scheduled waste period, these could be used to quickly measure the available traction. This data would then be exported to a process monitoring system. This would enable long-term statistical analysis to determine whether the system is degrading and nearing a condition that could result in waste.

TEST SETUP

Testing was conducted in the Optimization Technology Inc. Media Conveyance Facility (MCF) in Rochester NY. This machine is referred to as the Thin Web Rewinder (TWR). It has a dancer-controlled unwinder and winder, which is referenced to a nipped master drive roller. A diagram and photo of the machine is shown below in Figure 1.

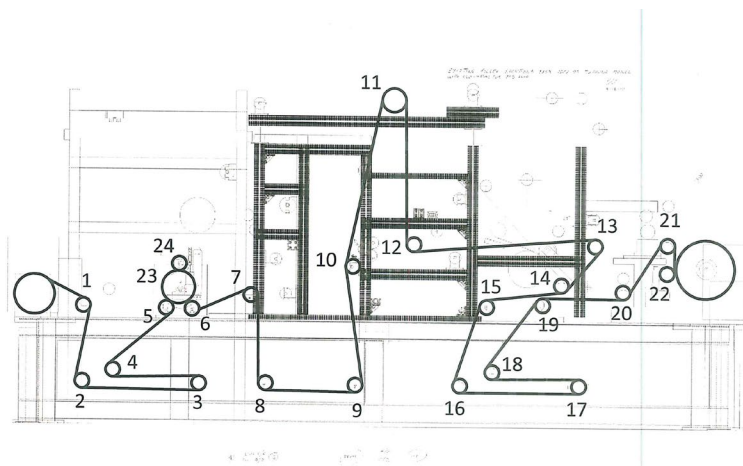

Figure 1 – TWR Thread Up



Figure 2 – TWR, Operator Side

A remotely actuated prony brake was installed on the machine, as seen in the following photo. Loading is accomplished through a pneumatic cylinder and the test roller is wrapped at 90 degrees. The applied braking force is supplied through a leather strap and is measured by a Revere Transducers, Inc. Model FT70, 100 lb. capacity strain gauge load cell.

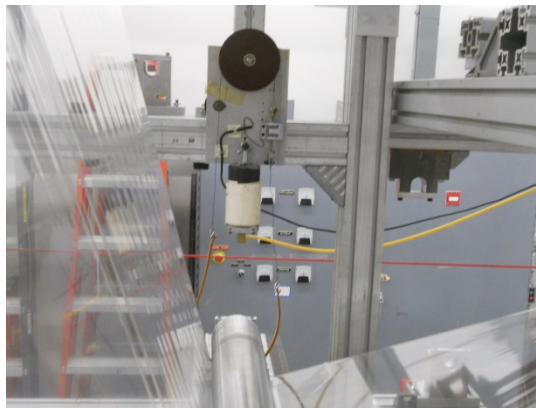

Figure 3 – Remote Actuated Prony Brake

Slip is detected by comparing the surface speed of the test roller to a high-wrap reference roller. The test roller has 90-deg. wrap and the reference roller is vented with a 24 groove/inch pattern, also with 90-deg. wrap. The speed is measured by Servo Tek Products Type SA7574-2 tachometers.

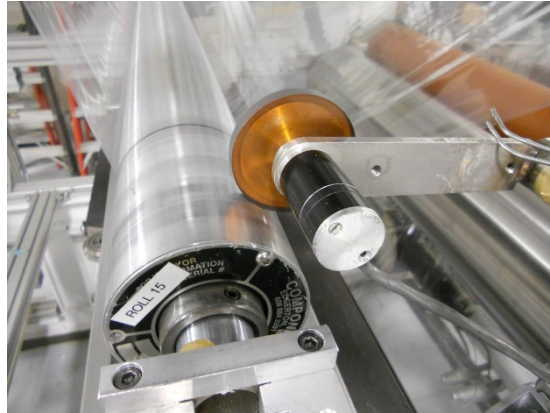

Figure 4 – Test Roller Tachometer



Figure 5 – Reference Roller Tachometer

Testing was done on an unvented roller using 0.00315-inch (8 micron) thick, 48-inch wide, polyester web. The tests were conducted with 2 levels of speed, 2 level of tension, and an external vibration source either off or on.

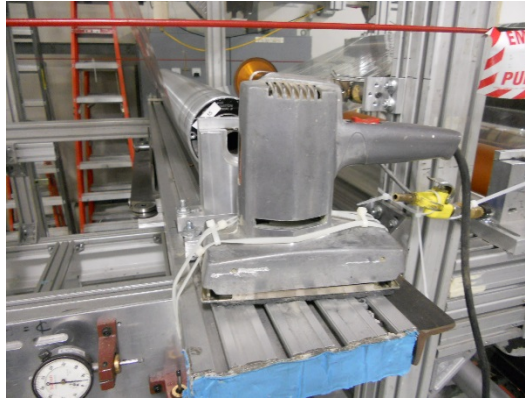

Figure 6 – External Vibration Source

To minimize the risk of measurement error, the test roller was defined as slipping when its speed had dropped by 5%, relative to the base speed of the test roller. Output of the calculations is in unitless terms of Coefficient of Traction (COT), which is obtained through manipulation of the capstan equation

$$COT = 1/\theta \ln(T_H/T_L). \quad \{1\}$$

TEST PROCEDURE

Control measurements were collected for each of the four test modes by engaging the TWR's tension controls and then engaging the DC drive motors at the desired setpoints. Upon observing a steady state from the TWR's Human Machine Interface (HMI), the LabVIEW system and the Python systems were engaged to collect data. Baseline samples were read for one minute. Following the collection of control measurements, the same procedure was used with the addition of the orbital sander to induce noise. The orbital sander simulates noise consistent with increased bearing drag / bearing failure in a web system. After thirty seconds of baseline data, the prony brake was engaged, and the system was measured for another minute. The addition of the prony brake and the sander simulates conditions where a bearing is about to fail and after failure, respectively.

Test ID	Speed, ft/min	Web Tension, lbs.	Fault Condition
Test 1	25	16	off
Test 2	50	16	off
Test 3	25	16	on
Test 4	50	16	on
Test 5	25	32	off
Test 6	50	32	off
Test 7	25	32	on
Test 8	50	32	on

Table 1 – Test Data

IMPLEMENTATION OF PYTHON AND LABVIEW FOR DATA COLLECTION

Data collection was achieved from two angles, a Python based OPC server/client pair, and a high-speed LabVIEW based cDAQ polling two tachometers and a load cell, located on the prony brake. LabVIEW systems can be preferred in environments where failure noise exceeds 1000Hz, the current limit to Allen Bradley Analog Input modules.

PYTHON AND ALLEN BRADLEY IMPLEMENTATION

Programmable Logic Controller (PLC) data was collected through an implementation of the PyLogix [2] library for Python. PyLogix is an open source, Apache 2.0 Licensed, Python implementation of the OPC protocol [3], used to communicate with PLC data. A 35Hz sample rate was achieved while polling 300 analog I/O tags. The sample rate of the data collection system has the potential to be increased, to the maximum supported by the PLC's Analog Input card, by decreasing the number of tags being polled. For this test environment, the PLC's data was used to confirm tension and speed setpoints. Future environments could be set up to integrate the tachometer or encoder modules with existing PLCs directly to detect and alert operators to potential failures, meaning many systems would require no additional DAQ hardware to implement the analysis used in this paper.

LABVIEW IMPLEMENTATION

A National Instruments (NI) cDAQ 9188 chassis with a NI-9205 voltage input card was used to measure real analog inputs from the two Servo Tek SA7574-2 tachometers and a Revere Transducers FT70 strain gauge load cell. The NI-9205 analog input module provides sixteen channels of $\pm 10V$ analog data with a maximum sample rate of 250kS/s. Other more economical DAQ devices would be sufficient for future test environments, while maintaining test integrity. Optical encoders can be used as a replacement for the tachometers and may be better suited for other applications. The simple setup of this data acquisition system enables portability of the test environment, allowing any existing web system to be analyzed.

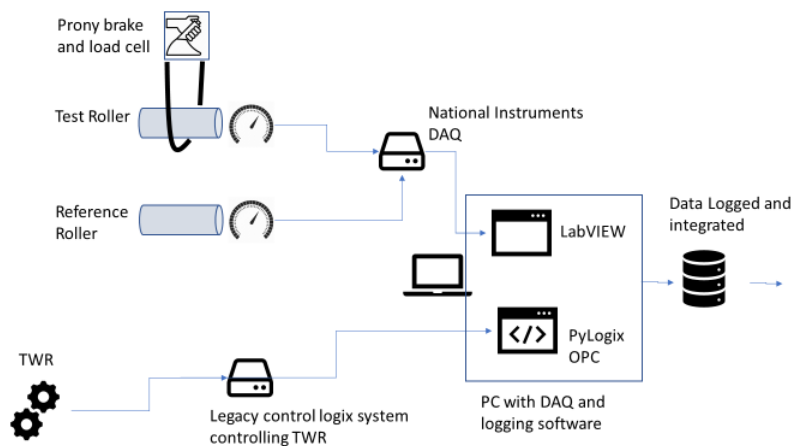

Figure 7 – Data Collection System Schematic Diagram

The software for data acquisition was written in LabVIEW 2017 with the DAQmx module. Implementing this program does not require purchasing software and can be run with a very small executable file. Samples were acquired at 1000 Hz for all three channels. Data was then streamed to a hard drive on a local PC. The files were written in a format compatible with Process Monitor software. Other options for data stores exist including server based hard disks, relational databases, and cloud storage. All of these methods allow live monitoring of the data by analytics software such as Process Monitor (see ANALYSIS & ANALYTICS section).

Originally the LabVIEW code was written for a slower data acquisition, 20Hz, and incorporated substantial filtering in the software. These software additions improved the user experience for operators with limited knowledge of the expected experiment noise, however, this limited the functionality of the analytics software. Higher data acquisition rates allow for deeper analysis of the system by Process Monitor, especially for identifying issues with FFT's.

While using transforms to analyze equipment is not a unique practice, especially with rotating equipment, the long-term application of FFTs would identify process symptoms that would otherwise not be identified, especially when quality is tied to all process variables.

ADDITIONAL FAILURE MODES OF INTEREST

Additional web system failure modes exist outside the scope of this experiment and condition-based modeling could be applied to prevent their occurrence. Variables of interest include wrap angle, roller surface roughness, web surface roughness, web planarity, roller venting, roller surface wear and contamination, machine speed, web tension variations, process temperature, and additional noise and vibration sources.

Recursive analysis could also be performed based on empirical product data; such as inconsistent coating, defects in rewinding and product marking. This allows operators to find an error after a production run and trace their steps back to where the defect occurred, using a historian or other database source. At this point, process analysis software such as Process Monitor can be implemented.

ANALYSIS & ANALYTICS

Process Monitor [4] is a powerful analytical application used for ad-hoc data exploration, on-line Statistical Process Control, Predictive Maintenance, and Machine Learning. In this paper, we will focus on presenting an ad-hoc analysis of the 2X2 experiment (Roller Speed, Web Tension) to calculate Coefficient of Traction (COT) for baseline conditions and for a simulated process fault (applied noise).

The graph in Figure 8 is for a normal 'No Noise' baseline test and shows where the analysis determines the slip point. As the applied load via the prony brake increases (green trace), the speed (blue trace) eventually drops precipitously. The red circled event mark shows where the speed has dropped 5% from its starting value. The value of the load at that point (red line) is fed into equation {1} to calculate a COT value.

The Roller 1 Speed before the Slip Point is not seen as it is almost identical to the Roller 2 speed (no offset).

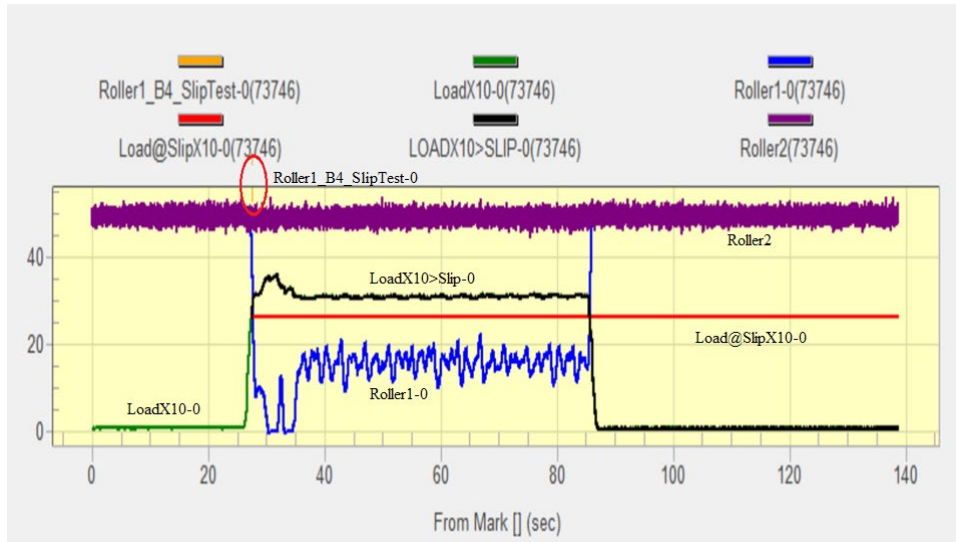

Figure 8 – Roller 1 Speed Before Slip

The graph in Figure 9 is for an Applied Noise test. Note the Roller 1 Speed before the Slip Point is now visible as it has dropped below the Roller 2 speed. As the load is applied, it falls further prior to the final precipitous drop. The circled event mark indicates where the signal has dropped below the 95% value, which is much earlier in the load test. The Load at Slip value is correspondingly lower which translates into the lower reported COT value.



Figure 9 – Roller 1 Speed with Noise Applied

Table 2 shows the calculated COT values for the test runs. The computed traction from the experiments is consistent with a first principles model, which predict a reduction of traction as speed increases. The % Diff statistic also shows lower values for all applied noise test conditions. The analysis is sensitive to signal noise and specific digital filtering parameters utilized. Future work should include repeat testing at each condition to increase confidence in the accuracy and precision of the results. The power of the method outlined in this paper is the ability of the procedure to uncover reduction in traction with noise present since first principles models don't include effects such as this.

Order	Experiment ID	Roller Speed (ft/m)	Roller Tension (lbs)	Noise (Y/N)	Wrap Angle (deg)	COT	% DIF (from No Noise Baseline)
3004191309	PET-50-32-wp6	50	32	N	90	0.43	
3004191316	PET-50-32-wp8	50	32	Y	90	0.42	-2.3
3004191304	PET-25-32-wp5	25	32	N	90	0.50	
3004191311	PET-25-32-wp7	25	32	Y	90	0.21	-58.0
3004191243	PET-50-16-wp2	50	16	N	90	0.28	
3004191254	PET-50-16-wp4	50	16	Y	90	0.24	-14.3
3004191239	PET-25-16-wp1	25	16	N	90	0.42	
3004191250	PET-25-16-wp3	25	16	Y	90	0.12	-71.2

Table 2 – Calculated COT Values

ADDITIONAL ANALYSIS

The noise level on Roller 1 speed can be analyzed by using a Fast Fourier Transform (FFT) [5]. As shown in Figure 10, the Roller 1 traces for Noise and No Noise have radically different looking time series.

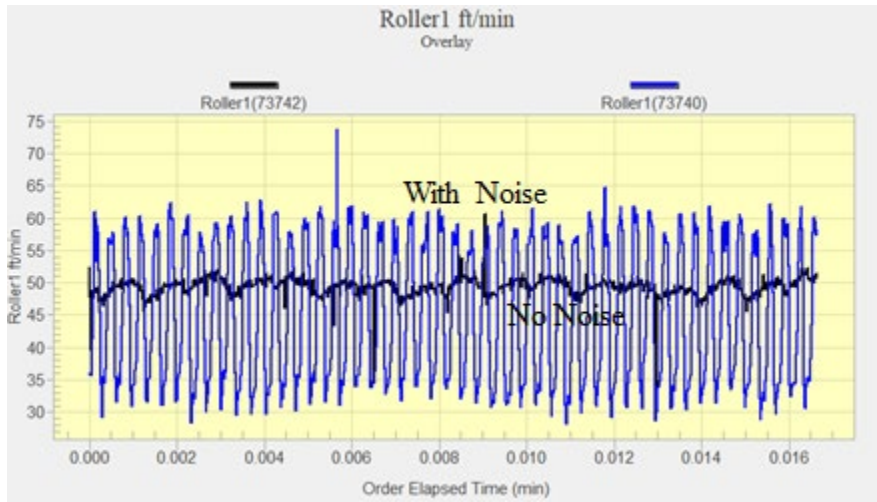

Figure 10 – Roller 1 Speed with and without Noise

The FFT can determine the frequency distribution of each. One relevant statistic is the Dominant Frequency, which we have found can be monitored at various points to determine if any process disturbances are occurring. This approach has been successfully applied across a wide variety of mechanical and chemical processes, if care is taken in setting up the data collection parameters relative to expected disturbance dynamics. We have found the analysis is useful on all classes of parameters, including PID controlled, PID manipulated, and dependent types.

Below, Figure 11 shows the respective FFT distributions for the traces. As expected, they are quite different and tracking the Dominant Frequency would allow one to identify a disturbance. This can be extended to other parameters as noted above.

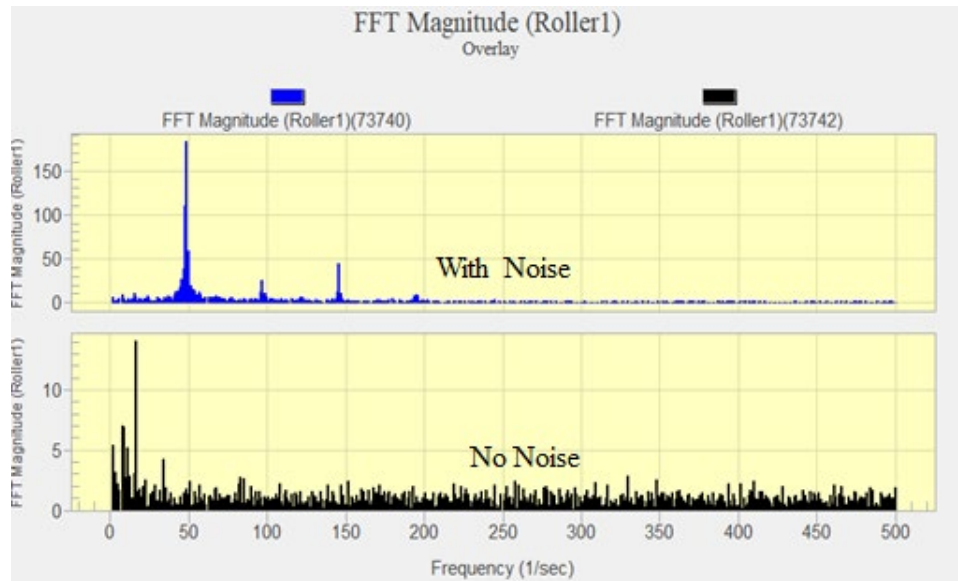

Figure 11 – Roller 1 FFT Magnitude

With sufficient process knowledge and data volume, a specific frequency distribution (or related statistic) can be identified with root causes. This analysis can be scheduled as part of a pre-startup test or during production runs. In the limit, machine learning techniques can model process behavior and identify significant changes from either a first principles model or a training set.

Optimization is an approved System Integrator for Process Monitor [6]. The PM system supports both off-line analyses and real time alarming and is available in both a traditional ‘on premise’ IT system as well as on Cloud based architectures.

CONCLUSIONS

Implementation of a Condition Based Monitoring approach to web handling preventative maintenance allows for the anticipation and avoidance of web handling-related product damage. By using a portable test development environment, as described in ‘TEST PROCEDURE’, in conjunction with analytics software such as Process Monitor, real-time process data collection can be set up and deployed in-process within hours. A setup similar to the test environment used in this experiment can effectively isolate traction related failures at below millisecond resolution, allowing production engineers to quarantine failures and apply process changes to specific timeframes, all without human inspection. This process improvement reduces the need for brute-force inspection of large quantities of product with historical methods such as surface scanners and manual inspection.

REFERENCES

1. Bentz, A.R., “Inexpensive Multipoint Roller Speed Measurement System”, Proceedings of the Fourth International Conference on Web Handling, Oklahoma State University, 1997.

2. PyLogix //github.com/dmroeter/pylogix.
3. OPC Foundation: <https://opcfoundation.org/>.
4. Process Monitor <https://www.kodak.com/us/en/science/Process-Monitor-Analytics-Software/default.htm>.
5. Fourier Transform: <http://www.jezzamon.com/forier/index.html>.
6. Optimization SI for PM: <https://blog.optimization.us/industry-4.0-what-is-the-return-on-investment>.