

## TENSION DISTURBANCES IN A TURRET WINDER

By

Clarence Klassen  
KlassENGINEERING, Inc.  
CANADA

### ABSTRACT

Turret winders are designed to produce batches of rolls from a continuously moving web. Typically, two spindles are mounted on a turret, 180 degrees apart. The winding roll remains in the inside (winding) position until it is nearly completed. Then the nearly completed winding roll is indexed to the outside (off-loading) position as a new core moves to the winding position. At the appropriate length, the web is cut and wrapped onto the fresh core at winding position.

While most of the roll winds in steady-state, indexing and transferring to the new core subjects the winding roll to numerous motions and changing traction points resulting in tension disturbances. The motions produce macro web length changes as the lay-on roller moves, and as the turret indexes. The incoming core contacts the web as the turret indexes. The web is nipped between the core and lay-on roller prior to the cut. The final insult is the cut and transfer of control to the inside spindle. We will discuss the impact of these disturbances on tension and roll quality. Controls to mitigate these disturbances will be suggested.

### NOMENCLATURE

A cartesian coordinate system will be used with the center of the turret at the origin. Rollers will be identified by subscript in the order they are contacted by the web with the exception of the outgoing winding roll (og) and the incoming core (ic).

$c$	web caliper [m]
$r_a$	radius of roller <sub>a</sub> [m]
$r_{og}$	outer radius of the outgoing roll [m]
$r_{ic}$	outer radius the incoming core [m]
$l_a$	distance from turret center to roller <sub>a</sub> center [m]
$l_{og}$	distance from turret center to spindle center [m]
$(x_a, y_a)$	coordinates of roller <sub>a</sub> center [m]
$(x_p, y_p)$	coordinates of lay-on roller pivot [m]

$l_p$	distance between lay-on pivot and lay-on roller center [m]
$\theta_{max}$	maximum pivot angle above horizontal [rad]
$l_2$	Distance c-c between idler rollers 2&3 and turret center [m]
$\alpha_t$	Turret angle measured to the center of the ic core [rad]
$l_{ab\_n}$	Span length from roller a to roller b at sequence step n [m]
$l_{ab}$	Span length from roller a to roller b for all sequence steps [m]
$\theta_{ia\_n}$	Wrap angular length for roller a at sequence step n [m]
$\theta_{ia}$	Wrap angular length for roller a for all sequence steps [m]
$(x_{ta\_n}, y_{tae\_n})$	Coords of roller a entry tangent point at sequence step n [m]
$(x_{tax\_n}, y_{tax\_n})$	Coords of roller a exit tangent point at sequence step n [m]
$\gamma_{ab\_n} \beta_{ab\_n} \theta_{ab\_n}$	Intermediate angles used to determine tangent points between rollers a and b at sequence step n [rad]

## TURRET WINDER OPERATION

Turret winders are designed to keep a continuous line running, not necessarily to keep tension variations to a minimum or to produce the best quality rolls. A turret winder consists of a turret with 2 or more spindles for winding web and handling rolls. We will discuss a winder with 2 spindles situated 180 degrees apart on a turret. The winding roll begins and proceeds in the winding position nearest the source of the web. When the roll has wound to near its specified diameter or length, the turret moves (indexes) the winding roll to the outside off-loading position and a new empty core to the winding position. The web is cut near the incoming core and winding begins for the new roll. The completed roll is off-loaded.

Note that there are a wide variety of turret winders, even winders with two spindles. The major design constraints are related to maximum roll width and roll diameter. Other constraints are related to the method of cutting the web, starting a new roll, whether a contact or gap mode of winding is required. Some differences may include:

- The web is cut at running speed or at zero speed with accumulation.
- A lay-on roller may or may not be supplied.
- Auxiliary lay-on rollers may be supplied to provide nip forces during the turret index.
- Idler rollers mounted on the turret at 90 degrees to the spindles may be supplied.
- Static pinning of the web may be supplied.
- Cores may be taped, glued, or work without adhesives.
- The winder may operate in under-wind or over-wind.

The motions involved with turret winders introduce a number of known sources of tension variations. These include changes in web path lengths, removing and adding nip forces, accelerations, and deceleration of winding rolls, and the introduction and removal of drive zones. All of these factors are worsened with stiff (non-extensible) materials and at low speeds. Turret winder motions which may affect web tension and roll quality include:

- The lay-on roller retracts and advances.
- The turret indexes.
- The diameter calculator or measurement loses accuracy.
- Undriven idler rollers contact the web at zero speed resulting in slip.
- The driven incoming core contacts the web.
- The lay-on roller creates an additional nip point at the core.
- The knife impacts or cross-cuts the web.
- Load cells or dancers may produce invalid measurements during the cycle.

- Closed loop tension regulation may be infeasible during the cycle.
- Roll taping affects the wound roll.
- The web may stop and re-start with accumulation.

These factors up to the web cut will be described and specific motions illustrated for a turret winder at speeds that show the required accelerations and decelerations. There is limited literature regarding changing web path lengths. Most related literature relates to industrial accumulators as described by Koç, Knittel, Abba, Mathelin, Gauthier, Ostertag [1] and Kuhm, Knittel [2].

## TURRET MOTIONS

The major components of a turret winder are represented with sample dimensions in Figure 1. Shown is the load cell roller, incoming roller 0, lay-on roller 1, driven outgoing winding roll (og), driven incoming core (ic) and idler rollers 2 and 3. The driven turret does not directly contact the web but affects web path geometry. The load cell roller is outside of the turret winder and has a fixed wrap angle. We consider the outgoing roll running in contact mode. The web contacts rollers 0, 1 and the og roll. Tension measured by the load cell is assumed to be nearly correct in the span  $l_{01}$  entering the lay-on roller.

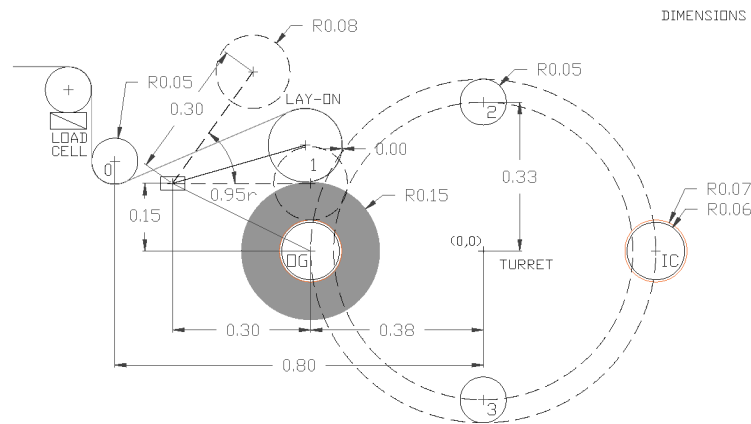

Figure 1 – Turret winder geometry showing the winding state

We are concerned with the length of the web from the entry to roller 0 and ending at the 0 radian or 3 o'clock position of the og roll. The winder length is the sum of roller and roll wrap angle lengths and span lengths. In this paper, we will provide formulas for calculating length. The formulas will consider the caliper and mid-line of the web as it wraps rollers. One alternative many will prefer is to use Computer Aided Drafting (CAD) to draw lines at *tangent* points between rollers and dimension the “*aligned span lengths*” and dimension “*arc lengths*” around the circles. A third alternative is to safely measure lengths on your actual winder. The initial (nominal) web path and sample web path length is shown in Figure 2.

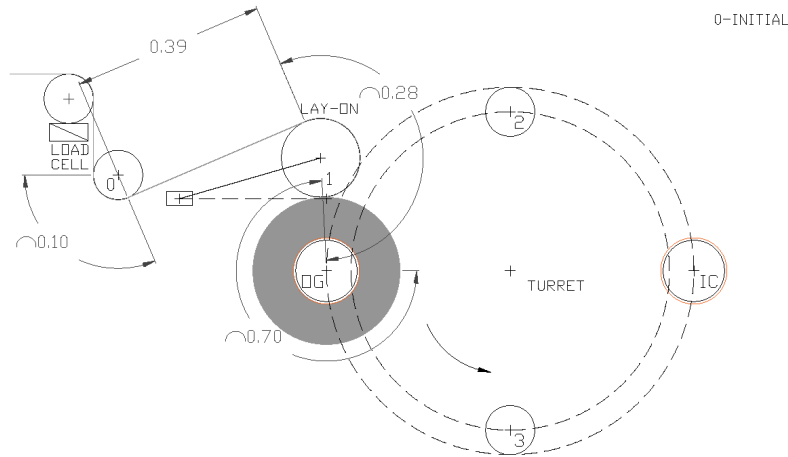

Figure 2 – Step 0 Turret winder initial web path and length

We will see that span lengths and wrap angle lengths change with each motion of the turret winder. Because the web entering roller 0 is assumed to be traveling at a constant velocity, the change in web path length implies velocity changes at each roller. For most of the cycle, the only driven traction point is the og roll. The ic core is driven but contacts the web only at the end of the cycle. The lay-on roller may also be driven on center-surface driven winders.

We also note that the layon roller adds a new nip point just prior to cutting the web. This impacts web tension measurement and control.

Many winder drive controls calculate og roll diameter using a ratio of web velocity (MPM) and og roll RPM (pulley equation). This calculation assumes that the web velocity entering the og roll is the same as the web velocity measured at an upstream roller. That assumption is incorrect during the index cycle and the diameter calculator is held (“*diameter hold*”) at the value immediately prior to initiating a cycle.

### **Lay-On Roller Retracts**

The optional lay-on roller running in contact mode is designed to provide a nip force on the surface of the winding roll directed toward the center of the roll. This nip force contributes greatly to roll stability and roll quality. The nip force is often provided with pneumatic cylinders and is a function of the pneumatic pressure.

The lay-on roller may also run in gap mode which provides no nip force, but does help with web stability and the amount of air entrained in the winding roll. Even when running in gap mode, the lay-on roller must often contact the incoming core for several wraps to ensure the winding roll starts well. The lay-on roller is supported with pneumatically loaded cylinders to provide controlled force in contact mode and to absorb impacts in normal operation.

The lay-on roller must move as the roll builds. The layout of the turret winder dictates how far the lay-on roller must be retracted in order to accommodate the largest go roll and to avoid a collision with turret idler roller #2 and the incoming core. This motion is often a simple pivot for a winder running in contact mode or a servo controlled

linear motion when gap mode is required. Either motion affects the web path length, but the mathematical calculation of the servo driven lay-on roller is simpler than for a pivot. This paper assumes a pivoting lay-on roller.

A pneumatically pivoted lay-on roller will generally move to its full stroke which is sufficient to accommodate the largest expected roll in the winding position. A servo controlled lay-on roller need only retract far enough to provide the needed clearance. In fact, depending on the diameter of the outgoing roll, the lay-on roller may not need to retract at all. The starting point for retracting the lay-on roller is determined by the diameter of the outgoing roll at the time the roll change is initiated.

In the case of a pivoted lay-on roller, a solenoid activates to direct pneumatic forces away from the og roll. Flow control valves on the cylinder can be used to control the speed of the lay-on roller pivot. The velocity of the cylinder ramps to the speed set by its flow control valve and reaches the end of stroke at this velocity. In the case of a servo-controlled lay-on roller, the lay-on roller is retracted at a speed set in the servo. The servo position trajectory is usually trapezoidal, that is it accelerates linearly to a specified velocity and then linearly decelerates to stop in the correct position. Retraction begins at the radius of the og roll. The speed of retracting the lay-on roller must balance the tension variations due to the additional length of non-standard winding produced before the cutover is completed. We often see the lay-on roller retract in 1 to 2 seconds.

Figure 3 shows the lay-on roller at its maximum retracted position. Slower transitions result in smaller disturbances, but take longer and affect more of the web. The distance traveled by the lay-on roller is dependent on the og roll diameter when the cycle is initiated. A new span  $l_{log}$  is introduced and angle lengths  $\theta_{11}$  and  $\theta_{12}$  change.

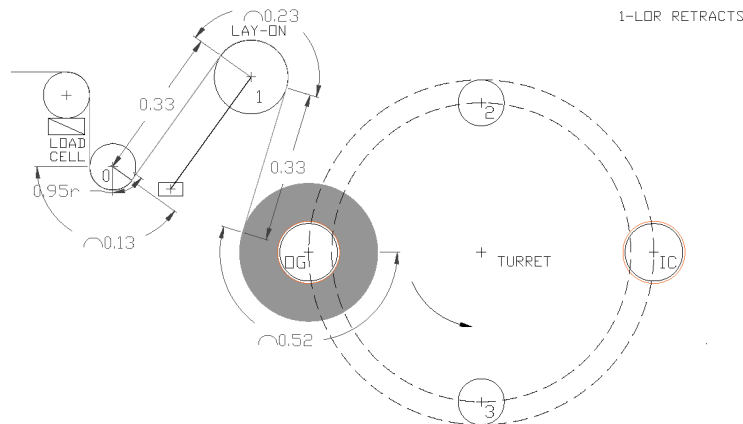

Figure 3 – Step 1 The lay-on roller retracts

Loss of the lay-on roller nip results in reduced wound-in tension in the og roll affecting roll quality. In gap mode, retracting the lay-on roller may also have more subtle effects on roll quality. Traditional drive controls have compensated for the loss of nip by applying a “*tension boost*” immediately prior to retracting the lay-on roller. Once the tension settled at its boosted level, the required og drive torque was “*memorized*” and held (“*torque hold*”) for the remainder of the cycle. The og drive operates in torque mode for the remainder of the cycle which permits speed variations as imposed by the web.

Because the torque is held at a fixed value, tension entering the og roll may vary as velocity changes.

**Turret Index**

The turret index typically moves the og roll using a fixed position or velocity trajectory. A *speed-controlled* trajectory may be a linear ramp to full speed, followed by a ramp to slow speed, and finally a ramped stop with the ic core ending at 0 radians. The acceleration, deceleration and full speed are adjustable.

A servo (position) controlled turret may follow a *position* trajectory with a trapezoidal S-Ramp for velocity. The S rounding time, acceleration and deceleration, and full speed are adjustable. A turret servo drive results in smoother and faster operation than a standard velocity-controlled drive.

Reduced acceleration and speed result in smaller disturbances, but take longer and affect more web. Slower motions affect cycle time and may reduce maximum line speed if short rolls are required.

**Idler Roller #2 Contacts Web.** The turret indexing away from the winding position increases the web path length in a complex way determined by the tangents between rollers. At a certain turret angle, roller 2 contacts the web. New spans  $l_{12}$ ,  $l_{2og}$ , and angle length  $\theta_{12}$  are introduced as shown in Figure 4.  $l_{2og}$  remains constant for the remainder of the cycle.

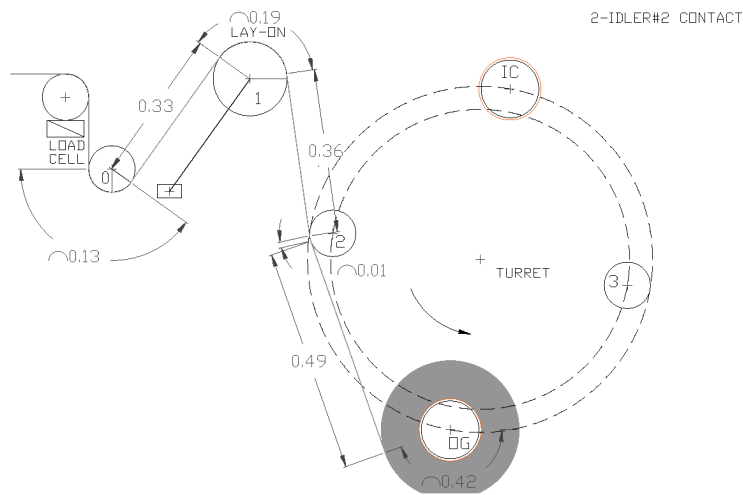

Figure 4 – Step 2 Turret indexes until idler 2 contacts the web

**Incoming Core Contacts Web.** As the index continues, the driven ic roll contacts the web as shown in Figure 5. The incoming core must be driven at the web speed of the span between roller 1 and 2. The ic diameter must be preset to the core outer diameter and held. New spans  $l_{1ic}$ ,  $l_{ic2}$ , and angle length  $\theta_{1ic}$  are introduced as shown in Figure 5.  $l_{ic2}$  remains constant for the remainder of the cycle. At this point, the ic drive begins to provide tension isolation between the load cell and the span from roller 2 to the og roll. No further web spans will be added, although their lengths will continue to change as the cycle progresses.

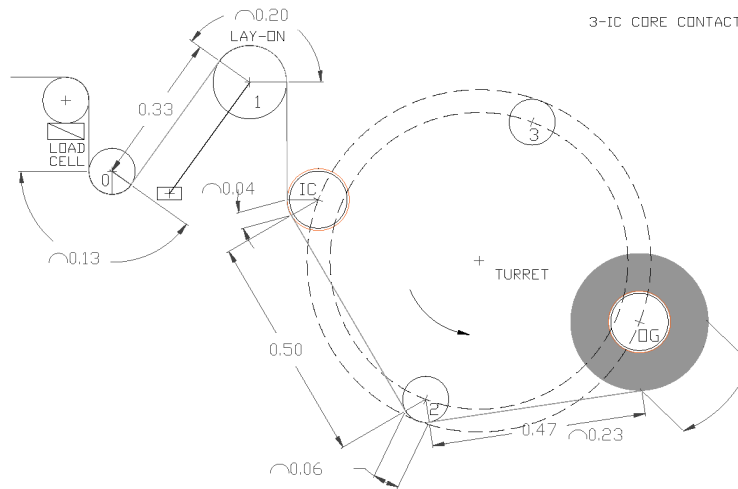

Figure 5 – Step 3 Turret indexes until the incoming core contacts the web

**Turret Stops in Position.** The index continues until the turret comes to a stop with the incoming core at turret angle of  $\pi$  radians as shown in Figure 6. At this point, the web path length is at its maximum.

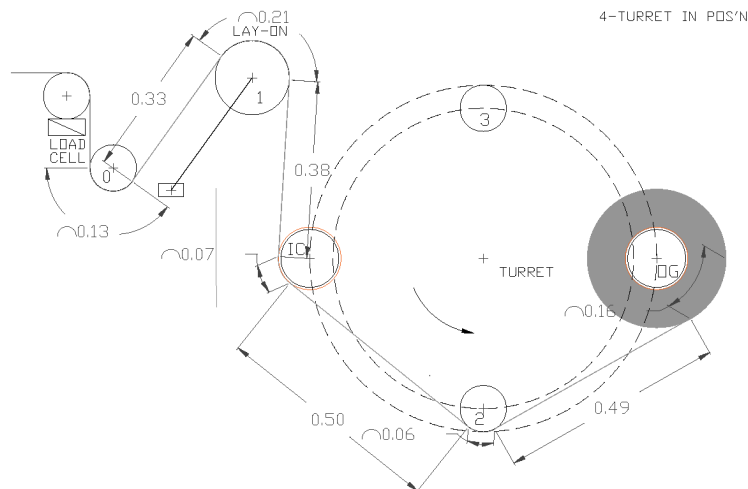

Figure 6 Step 4 Turret indexes until the core is in the winding position

**Lay-On Roller Advances to Core**

The optional lay-on roller must be brought into contact with the incoming core to ensure a good start to the new roll. The lay-on roller nip introduces a new traction point and tension zone into the winder system. We now have maximum isolation between the tension measurement and the og. The measured tension is greatly affected by the ic drive running in RPM velocity control. In this position, tension is very sensitive to RPM errors

in the ic drive. The og drive continues to operate in torque control but mainly affects the tension in the roller 2 to og span. There is no measurement of actual tension in this span.

Figure 7 shows the lay-on roller at its fully advanced position. The velocity of the lay-on roll pivot can be controlled with pneumatic flow control valves or other means. Slower transitions result in smaller disturbances, but take longer and affect more of the web. The distance traveled by the lay-on roller is constant for a fixed core outer diameter. The span  $l_{ic}$  approaches zero with this motion but wrap angle lengths increase.

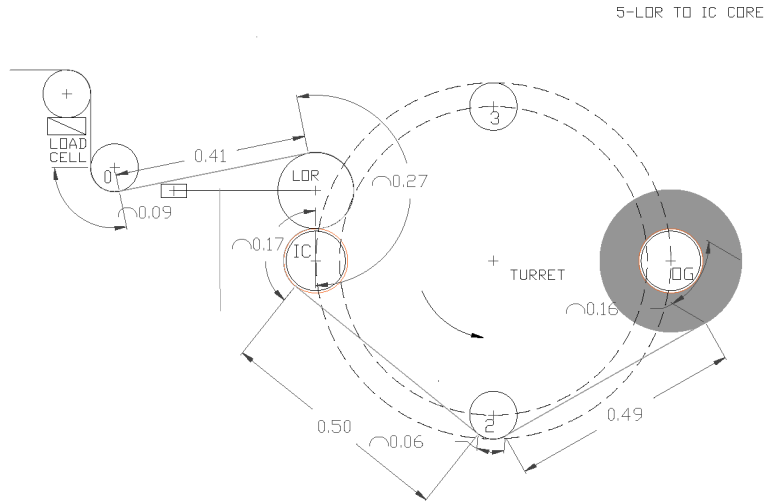

Figure 7 – Step 5 The lay-on roller advances to the core

The turret motions are now complete and ready for the knife cut at the desired length or diameter. Once the cut is complete, the cut edge is wrapped into the layon roller nip using glue, tape, static pinning or a mechanical enveloper. The ic core can no longer be considered incoming as it is now the actively winding roll. The winding drive is switched from RPM velocity control to torque control and a few wraps later is switched to tension control through the velocity regulator or the torque regulator. At this time, the diameter calculator is enabled for the new winding roll.

At the time of the cut, the og roll drive is stopped. If automatic taping is included, the tail is jogged up, tape heads lowered and the drive is jogged to complete taping. The og roll is then removed and new core loaded. Once this is complete the og roll becomes the ic core.

We will not discuss tension variations from the time of the cut onward.



**Tension or Drive Zones.** There are many and a changing number of rollers between the load cell and the og roll. In most cases, this represents a single drive or tension zone. However, after the turret index and before the cut, the lay-on roll advances to the ic core and creates a new drive pint with traction. The load cell will see tension created at the ic core and the og roll will pull tension only back to the layon roller. Fortunately, this condition lasts for only seconds.

### CHANGES IN WEB PATH LENGTH

As turret index motions occur, the distance the web path length changes as rollers approach and recede from each other. These web path length changes imply accelerations and decelerations. Unless drive points supply exactly the correct torque to provide this acceleration, energy will be extracted from the web with resulting tension variations. Many of the motions will be discussed in detail.

### Inner and Outer Tangents

Mathematics is available to find the shortest or tangent lines between rollers. Depending on the web path an outer or inner tangent may be applicable. These tangents are shown in Figure 8.

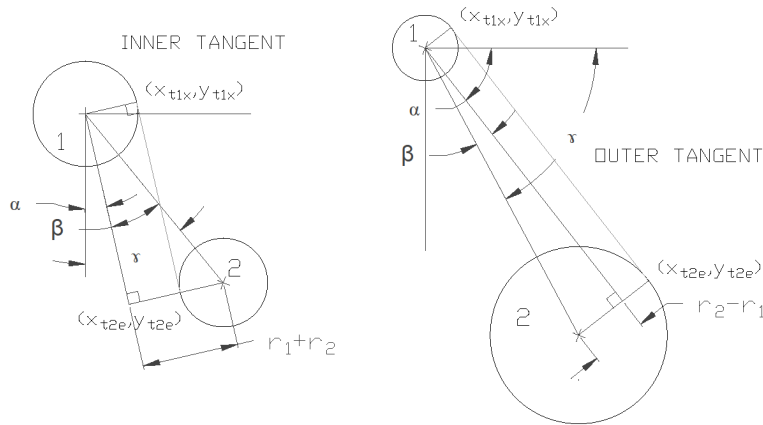

Figure 8 – Inner and outer tangents

For inner tangents the end points can be calculated as:

$$\gamma_{ab} = -\text{atan}\left(\frac{x_b - x_a}{y_b - y_a}\right) \quad \{1\}$$

$$\beta_{ab} = \frac{\pi}{2} - \text{acos}\left[\frac{r_a + r_b + \frac{2 \cdot c}{2}}{\sqrt{(x_b - x_a)^2 + (y_b - y_a)^2}}\right] \quad \{2\}$$

$$\alpha_{ab} = \frac{\pi}{2} + \gamma_{ab} - \beta_{ab} \quad \{3\}$$

$$x_{tax} = x_a + \left(r_a + \frac{c}{2}\right) \cdot \sin(\alpha_{ab}), \quad y_{tax} = y_a - \left(r_a + \frac{c}{2}\right) \cdot \cos(\alpha_{ab}) \quad \{4\}$$

$$x_{tbe} = x_b - \left(r_b + \frac{c}{2}\right) \cdot \sin(\alpha_{ab}), \quad y_{tbe} = y_b + \left(r_b + \frac{c}{2}\right) \cdot \cos(\alpha_{ab}) \quad \{5\}$$

For outer tangents the end points can be calculated as:

$$\gamma_{ab} = -\text{atan}\left(\frac{y_b - y_a}{x_b - x_a}\right) \quad \{6\}$$

$$\beta_{ab} = \text{asin}\left[\frac{r_a - r_b + \frac{2 \cdot c}{2}}{\sqrt{(x_b - x_a)^2 + (y_b - y_a)^2}}\right] \quad \{7\}$$

$$\alpha_{ab} = \gamma_{ab} - \beta_{ab} \quad \{8\}$$

$$x_{tax} = x_a - \left(r_a + \frac{c}{2}\right) \cdot \sin(\alpha_{ab}), \quad y_{tax} = y_a - \left(r_a + \frac{c}{2}\right) \cdot \cos(\alpha_{ab}) \quad \{9\}$$

$$x_{tbe} = x_b - \left(r_b + \frac{c}{2}\right) \cdot \sin(\alpha_{ab}), \quad y_{tbe} = y_b - \left(r_b + \frac{c}{2}\right) \cdot \cos(\alpha_{ab}) \quad \{10\}$$

The span length between the tangent endpoints is:

$$l_{ab} = \sqrt{(x_{tbe} - x_{tax})^2 + (y_{tbe} - y_{tax})^2} \quad \{11\}$$

Once the endpoints have been determined, the length of the span between rollers and the length of the web wrap around the roller can be calculated. The length of the wrap angle around the roller  $\theta_{la}$  uses normalized angles between  $\pm\pi$  radians resulting from an arctan2 function. A function arcdiff calculates the angle defined from  $\theta_0$  to  $\theta_1$  in the CCW direction and is shown in equation {14}. Note the web path does not always follow the surface of the roller in the CCW direction.

$$\theta_{ea} = \text{atan2}(x_{tae} - x_a, y_{tae} - y_a), \quad \theta_{xa} = \text{atan2}(x_{tax} - x_a, y_{tax} - y_a) \quad \{12\}$$

$$\theta_{la} = \left(r_a + \frac{c}{2}\right) \cdot \text{arcdiff}(\theta_{xa}, \theta_{ea}) \quad \{13\}$$

$$\text{arcdiff}(\theta_0, \theta_1) = \text{mod} \left[ \frac{\left[ \left[ (\theta_0 \geq 0) \wedge (\theta_1 \geq 0) \right] \vee \left[ (\theta_0 < 0) \wedge (\theta_1 < 0) \right] \vee \left[ (\theta_0 < 0) \wedge (\theta_1 \geq 0) \right] \right] \cdot (\theta_1 - \theta_0) \dots, 2\pi}{\left[ (\theta_0 \geq 0) \wedge (\theta_1 < 0) \right] \cdot (2\pi - \theta_0 + \theta_1) + 2\pi} \right] \quad \{14\}$$

### **Lay-On Roller Retracts and Advances**

The web length as a function of time is presented for the case of the pivoting lay-on roller. See Schuster and Oedl [3] for the mathematics of a servo-driven lay-on roller.

To derive the web path length change as the lay-on roller pivots refer to Figures 3 and 7. The length will be calculated from the infeed tangent point on idler roller #1 to the point of contact (or the tangent of the outgoing roller).

In normal contact mode running the point of contact between the lay-on roller and the og roll is solved as the point where the distance between the centers of roller 1 and the og roll equals the sum of the radii plus the web caliper. The second condition is the center of roller 1 must follow a radius determined by the lay-on pivot arm. The equation for determining the position of the lay-on roller in contact mode is too long for presentation. Many will prefer to find this point using a CAD program.

The lay-on roller position  $\theta_p(t)$  and turret angle  $\alpha_t(t)$  can be defined as a function of time. The lay-on pivots away for the 1<sup>st</sup> second and advances toward the ic core between 7 and 8 seconds. The turret indexes between 1 and 6 seconds.

$$\theta_p(t) = \begin{cases} \min \left[ \theta_{pog} + (\theta_{\max} - \theta_{pog}) \cdot \frac{t}{1s}, \theta_{\max} \right] & \text{if } t < 7s \\ \max \left[ \theta_{\max} - (\theta_{\max} - 0.034) \cdot \frac{t - 7s}{1s}, 0.034 \right] & \text{otherwise} \end{cases} \quad \{15\}$$

$$\alpha_t(t) = \max \left[ \min \left[ 0 + (\pi) \cdot \frac{(t - 1s)}{5s}, \pi \right], 0 \right] \quad \{16\}$$

The total path length for the web for is the sum of lengths shown below:

$$\text{Len}(t) = \theta_{10} + l_{01} + \theta_{11} + l_{1to} + \theta_{1ic} + l_{ict0} + \theta_{12} + l_{2to} + \theta_{1og} \quad \{17\}$$

Many of the lengths are piecewise functions of the lay-on position and the turret position depending on the sequence step. The span lengths and wrap angle lengths are shown below.

Roller 0 has a fixed entry tangent but the exit tangent is a function of the lay-on pivot angle which is a parametric function of time.

$$l_{01}(t) = \begin{cases} l_{01\_1}(t) & \text{if } \alpha_t(t) < \pi \\ l_{01\_4}(t) & \text{otherwise} \end{cases} \quad \{18\}$$

The lay-on roller 1 exit span is a function of the lay-on position and the turret position. The span may end at the entry of the og roll or roller 2 or the ic core. For the example given, roller 2 contacts the web at a turret angle of 1.3 radians and the ic core at 2.5 radians. This span length approaches zero when the lay-on roller is in contact with the og roll or the ic core.

$$l_{1to}(t) = \begin{cases} l_{1og}(t) & \text{if } \alpha_t(t) < 1.3 \\ l_{12}(t) & \text{if } (\alpha_t(t) \geq 1.3) \wedge (\alpha_t(t) < 2.5) \\ l_{1ic}(t) & \text{otherwise} \end{cases} \quad \{19\}$$

The span length from roller 2 to the og roll varies only as the tangent points change very slightly.

$$l_{2to}(t) = \begin{cases} l_{2og}(t) & \text{if } \alpha_t(t) \geq 1.3 \\ 0 & \text{otherwise} \end{cases} \quad \{20\}$$

The span length from the ic core to roller 2 varies only slightly as a function of the wrap angle.

$$l_{ic2o}(t) = \begin{cases} l_{ic2}(t) & \text{if } \alpha_t(t) \geq 2.5 \\ 0 & \text{otherwise} \end{cases} \quad \{21\}$$

In a similar way, the wrap angle lengths are calculated.

$$\theta_{10}(t) = \theta_{10\_4} \quad \{22\}$$

$$\theta_{11}(t) = \begin{cases} \theta_{11\_1}(t) & \text{if } \alpha_t(t) < 1.3 \\ \theta_{11\_2}(t) & \text{if } (\alpha_t(t) \geq 1.3) \wedge (\alpha_t(t) < 2.5) \\ \theta_{11\_4}(t) & \text{if } \alpha_t(t) \geq 2.5 \end{cases} \quad \{23\}$$

$$\theta_{12}(t) = \begin{cases} 0 & \text{if } \alpha_t(t) < 1.3 \\ \theta_{12\_2}(t) & \text{if } (\alpha_t(t) \geq 1.3) \wedge (\alpha_t(t) < 2.5) \\ \theta_{12\_3}(t) & \text{if } \alpha_t(t) \geq 2.5 \end{cases} \quad \{24\}$$

$$\theta_{lic}(t) = \begin{cases} 0 & \text{if } \alpha_t(t) < 2.5 \\ \theta_{lic\_3}(t) & \text{otherwise} \end{cases} \quad \{25\}$$

$$\theta_{log}(t) = \begin{cases} \theta_{log\_0}(t) & \text{if } \alpha_t(t) = 0 \\ \theta_{log\_1}(t) & \text{if } \alpha_t(t) < 1.3 \\ \theta_{log\_2}(t) & \text{if } (\alpha_t(t) \geq 1.3) \wedge (\alpha_t(t) < 2.5) \\ \theta_{log\_3}(t) & \text{if } \alpha_t(t) \geq 2.5 \end{cases} \quad \{26\}$$

The change in length [m] can be plotted as shown in Figure 9 when specific parameters are entered into the calculation. In general, the web length increases until the lay-on roller is lowered onto the ic core.

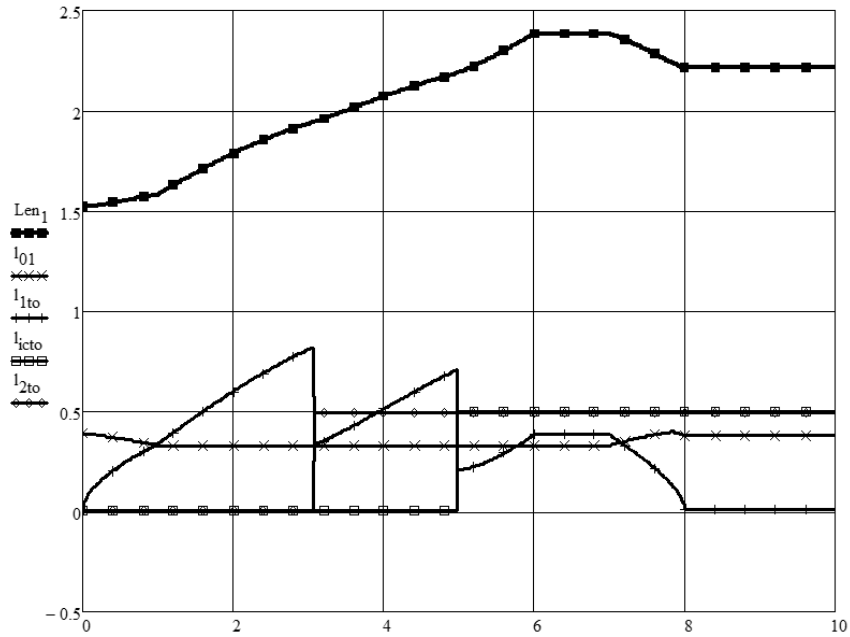

Figure 9 – Change in span length during a turret sequence

The web enters the winder at a constant velocity. To accommodate the change in length, the velocity of the og roll must change. This roll has considerable inertia which is different for different products and very different for different roll diameters. We expect the tension variations in the winder will correlate with the negative Delta Velocity [m/s]. Physical effects such as rotational inertia will smooth the velocity curve but may increase tension variations. Figure 10 shows the change in length and the derivative or velocity at the og roll. Velocity changes for this example are up to 0.22 m/s or 13 mpm. For many slow webs, the og roll may have to rotate backward and unwind during the index cycle. We note that tension variations are greater at low line speed, and are greater with stiff material.

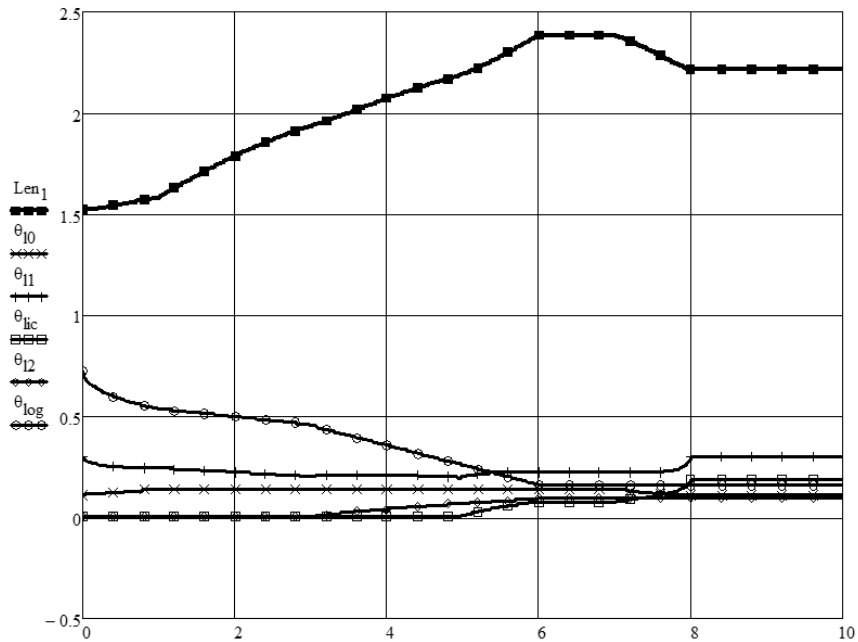

Figure 10 – Change in wrap angle length during a turret sequence

The step changes in the velocity seen at the og roll occur when the web path has drastic changes. Specifically, these changes are:

- Lay-on roller retracts from the og roll
- The turret accelerates
- Roller 2 contacts the web at zero speed. Not included in of the model is that the web will accelerate roller 2.
- The ic core contacts the web. Its speed must be set to match the web, not line speed. At the time and point of contact, the web is traveling at approximately line speed, with the og roller moving more slowly.
- The turret ramps to a stop in position
- The lay-on roller advances to the ic core. The web travels over the core faster than line speed at this time.
- The lay-on roller and the driven ic core form a nip and new tension zone. The web at the ic spindle returns to line speed.

Not discussed in this paper is the cut and transition of tension control to the ic core when it becomes the winding roll. We will not discuss taping of the roll and unloading.

We note that at each speed step, various rolls and rollers must accelerate or decelerate. The opposite speed change will be required a short time later as the winder eventually settles back to running at line speed. The undriven rollers must be accelerated or decelerated by the web, resulting in tension disturbances. Driven rollers must match the speed of the web at every instance or will introduce tension variations.

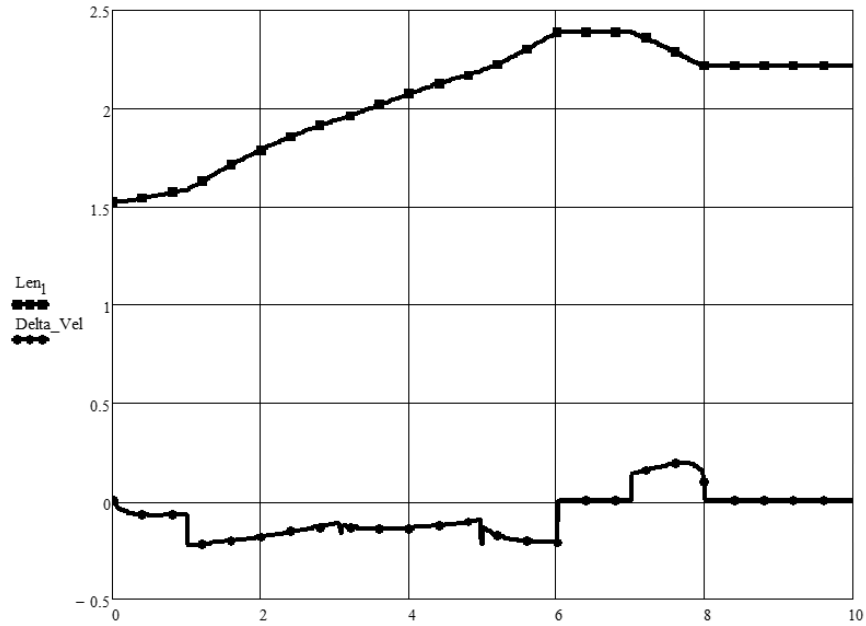

Figure 11 – Change in length and velocity during a turret sequence

Figures 12 and 13 show actual tension and RPM trends for a turret winder similar to the winder discussed in this paper. Some differences are that the optional rollers 2 and 3 are not present and the web is stopped in the winder for the cut. An accumulator allows the line to continue running. This winder runs without a lay-on roller but uses the lay-on roller for starting each new roll.

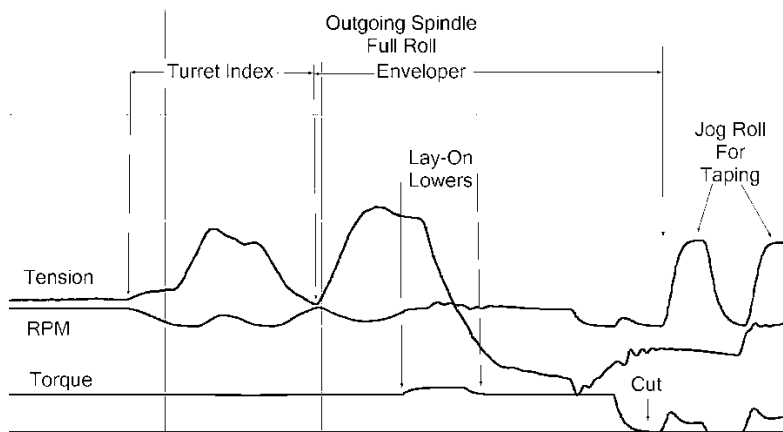

Figure 12 – Tension and og RPM for a turret sequence

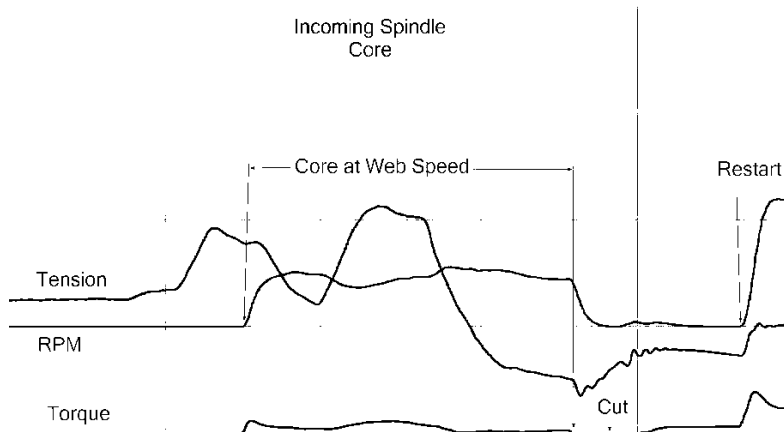

Figure 13 – Tension and ic RPM for a turret sequence

Figure 11 shows the og roll running with “torque hold”. Figure 11 shows the ic core running in RPM velocity control. Tension shows 2 substantial peaks during the turret index. And then low tension as the lay-on roller is lowered before the cut. These tension spikes are naturally reduced at higher line speeds and with an extensible web.

## DESIGN RECOMMENDATIONS

To minimize roll defects during turret winder index sequences, we make the following recommendations. These recommendations may not be adequate for your web and a different winder may be required.

The winder should be sized for the rolls being produced. Reduce excessive motion related to large diameters. Use accurately driven rolls. Schuster and Oedl [3] described how servo control for the turret and lay-on roller can allow coordinated motions that reduce web length changes.

The actual winder shown in the trends above was optimized with standard drive controls. Feed-forward controls were added to adjust the torque for the og roll to reduce tension variations. This was done empirically by monitoring the load cell feedback and observing the quality of the finished rolls. Worth repeating is that the load cell tension measurement is a great distance from the og roll and for part of the cycle is isolated by the lay-on to ic core nip.

Feedforward controls were added to the og roll drive when the lay-on roller pivoted in both directions. A turret position encoder was available to adjust torque based on turret position, assuming the velocity would be repeatable. Torque was adjusted for every 15 degrees of turret rotation. The specific feed-forward techniques applied were described by the author [4].



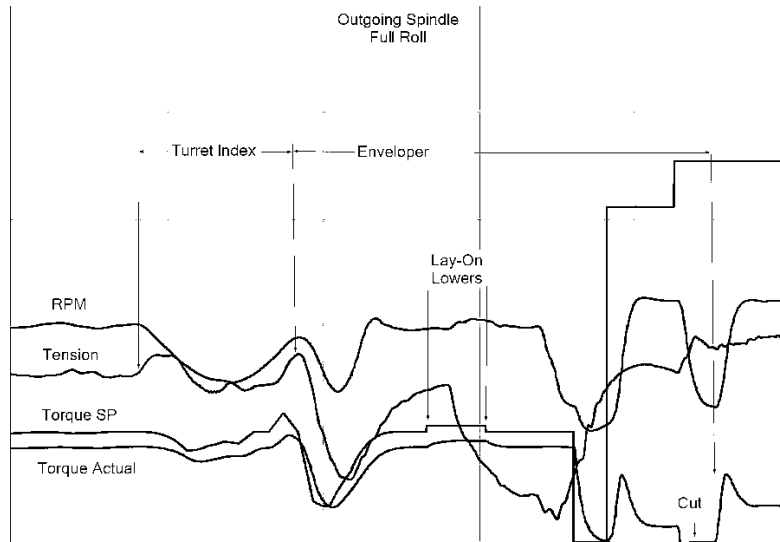

Figure 14 – Tension and og roll RPM with feed-forward control

## CONCLUSIONS

We observe that turret winders subject the web to tension disturbances during index cycles. These disturbances are more severe at lower line speeds and with stiffer (high modulus) webs. It may be necessary to use feed-forward techniques to minimize tension variations. These will compensate for turret motion, lay-on roller motion, core speed, enveloping and cutting of the web. A faster index cycle will minimize the interval over which the disturbances occur but will increase the magnitude of tension variations. It may be that a turret winder is not recommended for your particular web.

## REFERENCES

1. Koç, H., Knittel, D., Abba, G., Mathelin, M. de, Gauthier, C., and Ostertag, E., "Modeling and Control of an Industrial Accumulator in a Web Transport System," Proceedings of 1999 European Control Conference (ECC), Karlsruhe, Germany, 31 Aug.-3 Sept. 1999.
2. Kuhm, David, and Knittel, Dominique, "New Design of Robust Industrial Accumulators for Elastic Webs," IFAC Proceedings Volumes, Volume 44, Issue 1, January 2011, pp. 8645-8650.
3. Schuster, S. and Oedl, G., "Fast Winder Change with Reduced Influence on Film Tension," Proceedings of the 13th International Conference on Web Handling, Web Handling Research Center, Oklahoma State University, June 7-10, 2015.
4. Klassen, Clarence, "Tension Control in Turret Winding," Converting Quarterly, 2019 Quarter 1, pp. 70-76.