

(12) **United States Patent**
Materer et al.

(10) **Patent No.:** **US 7,675,295 B2**
(45) **Date of Patent:** **Mar. 9, 2010**

(54) **PASSIVE WIRELESS CORROSION SENSOR**

(75) Inventors: **Nicholas F. Materer**, Stillwater, OK (US); **Allen W. Apblett**, Stillwater, OK (US)

(73) Assignee: **The Board of Regents for Oklahoma State University**, Stillwater, OK (US)

(*) Notice: Subject to any disclaimer, the term of this patent is extended or adjusted under 35 U.S.C. 154(b) by 236 days.

(21) Appl. No.: **11/850,496**

(22) Filed: **Sep. 5, 2007**

(65) **Prior Publication Data**
US 2009/0058427 A1 Mar. 5, 2009

(51) **Int. Cl.**
G01R 27/00 (2006.01)
(52) **U.S. Cl.** **324/649**; 324/76.11; 343/867
(58) **Field of Classification Search** 324/700,
324/71.2, 649, 76.1; 340/601; 205/775.5;
343/866, 867
See application file for complete search history.

(56) **References Cited**
U.S. PATENT DOCUMENTS

3,716,460 A *	2/1973	Weisstuch et al.	205/775.5
4,677,373 A	6/1987	Kobayashi et al.	
5,122,330 A	6/1992	Solomon et al.	
5,338,432 A	8/1994	Agarwala et al.	
5,446,369 A	8/1995	Byrne et al.	
6,805,788 B1	10/2004	Gonzalez-Martin et al.	

6,806,808 B1	10/2004	Watters et al.	
6,894,512 B2 *	5/2005	Girshovich et al.	324/694
6,911,828 B1	6/2005	Brossia et al.	
2004/0113790 A1	6/2004	Hamel et al.	
2006/0002815 A1	1/2006	Harris et al.	
2006/0125493 A1 *	6/2006	Subramanian et al.	324/700

FOREIGN PATENT DOCUMENTS

JP	1296156	11/1989
JP	2000304684	11/2000

OTHER PUBLICATIONS

PCT International Search Report, International Application PCT/US2008/074340, mailed Feb. 25, 2009.
PCT Written Opinion of the ISA, International Application PCT/US2008/074340, mailed Feb. 25, 2009.

* cited by examiner

Primary Examiner—Vincent Q Nguyen
(74) *Attorney, Agent, or Firm*—Fellers, Snider, Blankenship, Bailey & Tippens

(57) **ABSTRACT**

A passive wireless corrosion sensor is disclosed. A circuit is configured to provide a signal response when energized. An antenna is configured to wirelessly receive energy for energizing the circuit and to receive the signal response from the circuit and transmit the signal response. A corrosion sensitive connector interposes the circuit and the antenna. The corrosion sensitive connector conducts the energy from the antenna to the circuit and conducts the signal response from the circuit to the antenna when in a substantially non-corroded state. The corrosion sensitive connector creates an effectively non conducting link between the antenna and the circuit when in a substantially corroded state.

8 Claims, 3 Drawing Sheets

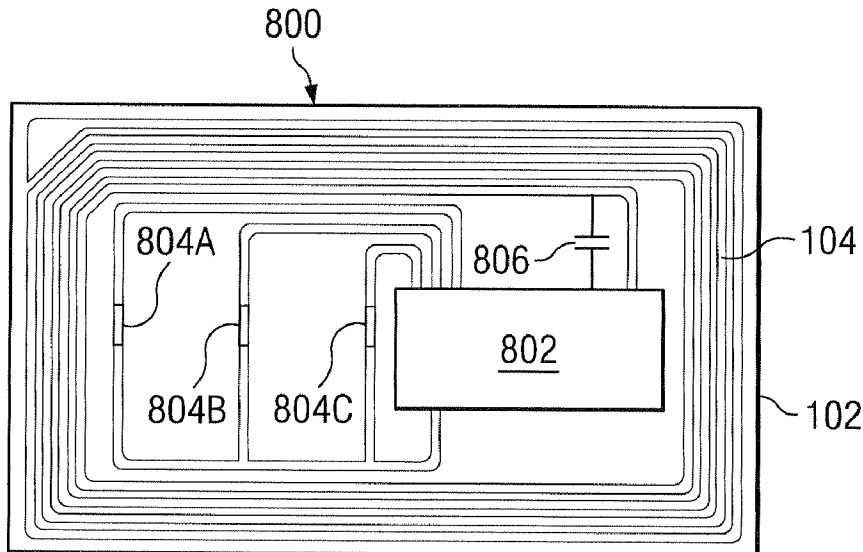

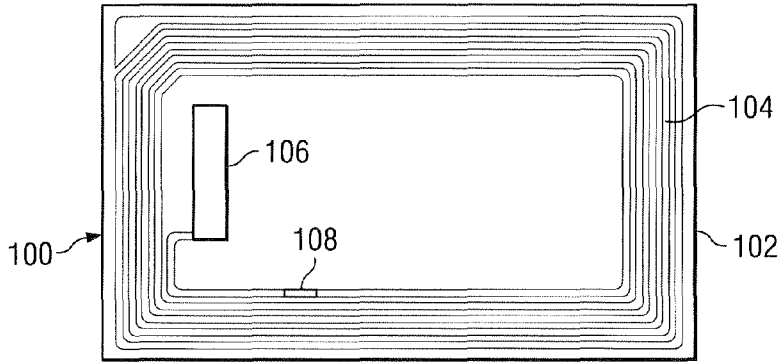

FIG. 1

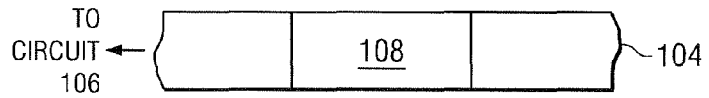

FIG. 2A

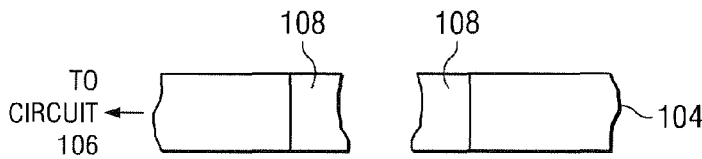

FIG. 2B

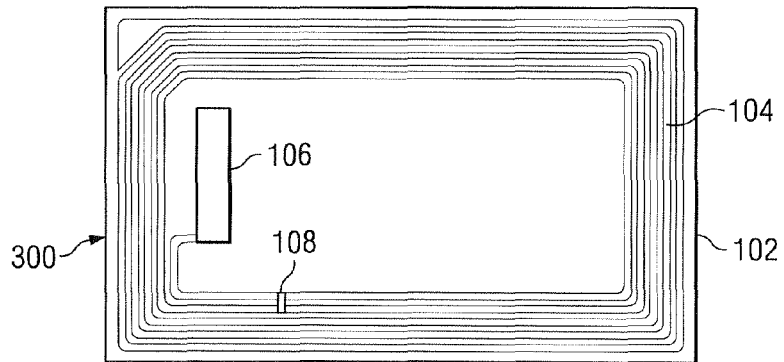

FIG. 3

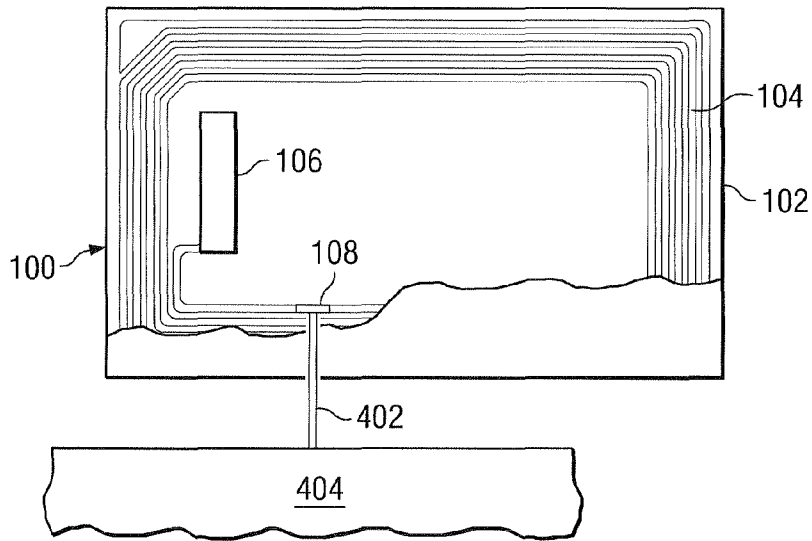

FIG. 4

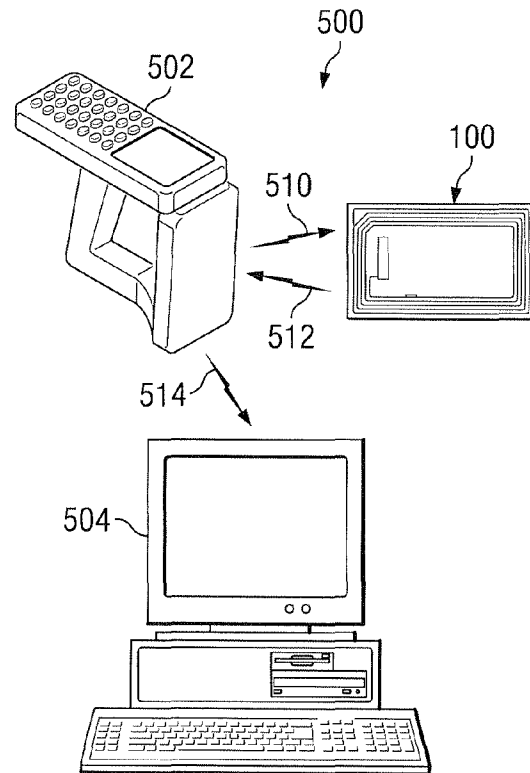

FIG. 5

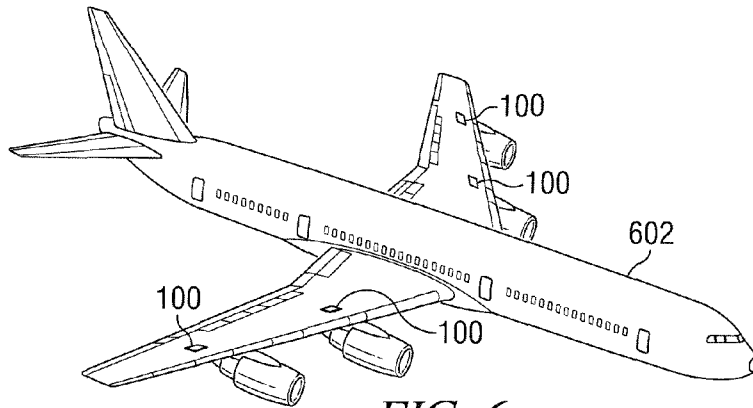

FIG. 6

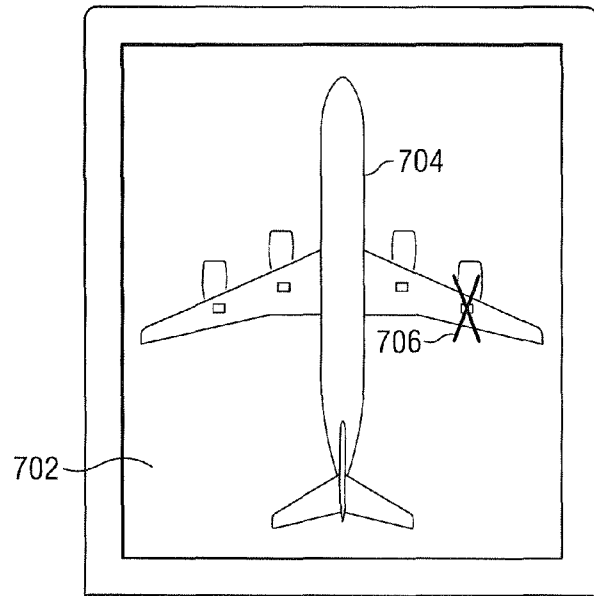

FIG. 7

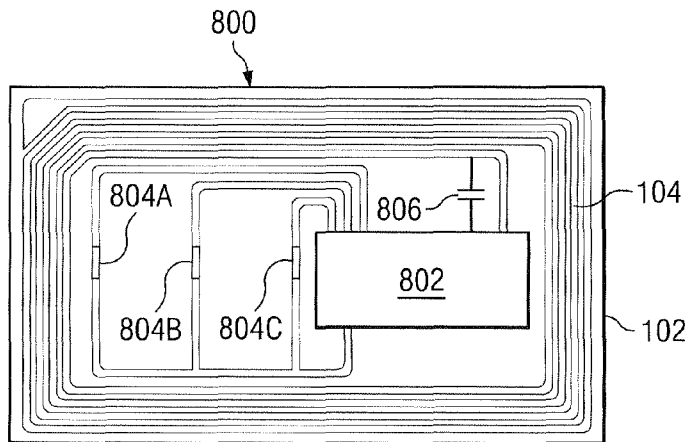

FIG. 8

PASSIVE WIRELESS CORROSION SENSOR

FIELD OF THE INVENTION

This disclosure relates generally to corrosion sensors. More particularly, but not by way of limitation, this disclosure relates to wireless corrosion sensors, systems, and methods.

BACKGROUND OF THE INVENTION

Almost every man made construction is subject to corrosive forces. Corrosion affects aircraft, trains, automobiles, pipelines, factories, and a host of other devices, buildings, structures, and apparatus. In the United States alone, costs associated with policing and repair of corrosion runs into the hundreds of billions of dollars. Industrial segments including transportation, utilities, production and manufacturing, governments, and other infrastructure have a need to detect corrosion prior to significant damage occurring to the structure of interest

In some instances, the cost to repair damages due to corrosion will be greater than half of the original costs to build the structure. These costs are exclusive of the other costs associated with the loss of use of a corroded structure such as loss production and capacity. Moreover, in some instances, environmental impacts are to be considered such as with the corrosion of an oil pipeline or another structure containing toxic or otherwise harmful materials.

What is needed is a system and method of addressing the above, and related, issues.

SUMMARY OF THE INVENTION

The present invention disclosed and claimed herein, in one aspect thereof comprises a passive wireless corrosion sensor. The sensor includes a circuit configured to provide a signal response when energized and an antenna configured to receive energy for energizing the circuit. The antenna receives the signal response from the circuit and transmits the signal response. A corrosion sensitive connector interposes the circuit and the antenna. The corrosion sensitive connector conducts the energy from the antenna to the circuit and conducts the signal response from the circuit to the antenna when in a substantially non-corroded state. The corrosion sensitive connector creates an effectively non conducting link between the antenna and the circuit when in a substantially corroded state.

In another embodiment disclosed herein the corrosion sensitive connector substantially prevents conduction of energy from the antenna to the circuit and substantially prevents conduction of the signal response from the circuit to the antenna when in a substantially non-corroded state.

In another embodiment an integrated circuit is powered by the interrogation signal from the antenna. A plurality of corrosion sensitive connectors is connected to the integrated circuit. In response to the interrogation signal the integrated circuit provides a continuity test of each of the plurality of corrosion sensitive connectors and provides a response back through the antenna indicative of the continuity test results.

The present invention disclosed and claimed herein in another aspect thereof comprises a method of modeling corrosion of a test object. The method includes applying one or more passive wireless corrosion sensors to a test object in locations where corrosion is monitored. The method includes wirelessly energizing the plurality of passive wireless corrosion sensors, and receiving a plurality of signal responses from the plurality of passive wireless corrosion sensors.

BRIEF DESCRIPTION OF THE DRAWINGS

FIG. 1 is a schematic diagram of a passive wireless corrosion sensor according to aspects of the present disclosure;

FIG. 2a is a close up cutaway view of the antenna and corrosion sensitive connector of FIG. 1 with the corrosion sensitive connector substantially intact;

FIG. 2b is a close up cutaway view of the antenna and corrosion sensitive connector of FIG. 1 with the corrosion sensitive connector substantially corroded and open;

FIG. 3 is another embodiment of a wireless corrosion sensor according to aspects of the present disclosure;

FIG. 4 is a schematic diagram of the corrosion sensor of FIG. 1 in a configuration to detect galvanic corrosion;

FIG. 5 is a diagram of one embodiment of a system for monitoring corrosion using wireless passive corrosion sensors according to the present disclosure;

FIG. 6 is an illustration of one possible placement of wireless passive corrosion sensors on a test object;

FIG. 7 is a graphical display of a test object being monitored for corrosion; and

FIG. 8 is another embodiment of a wireless corrosion sensor according to aspects of the present disclosure.

DETAILED DESCRIPTION OF THE PREFERRED EMBODIMENTS

Referring now to FIG. 1, a schematic diagram of a passive wireless corrosion sensor is shown. The sensor **100** is passive in that it does not contain a power source and is inactive until energized by radiofrequency, magnetic, or microwave energy, or other wireless energy fields. In the present embodiment, the sensor **100** is based upon radio frequency identification (RFID). The sensor **100** may be based upon a commercially available RFID tag or may be specifically made as described herein. The sensor **100** has a substrate or covering **102**. The covering **102** may be plastic, Mylar®, rubber, or another suitable material. Contained within the covering **102** is the antenna **104**. The antenna **104** is connected to a circuit **106** via a corrosion sensitive link or connector **108**. The antenna **104** will be used to receive radiofrequency energy, magnetic energy, or other wireless energy that will be used to energize or power the circuit **106**. It can be seen that the corrosion sensitive connector **108** interposes the antenna **104** and the circuit **106**. All or a portion of the corrosion sensitive connector **108** will be exposed to the ambient environment such that the corrosiveness of the environment and/or the actual corrosion of a test object can be detected.

As is known in RFID technology, the antenna **104** will be used to receive wireless energy from an outside source. The energy may be stored within the circuit **106**, possibly within a capacitor. When energized, the circuit **106** is capable of returning a signal back through the antenna **104**. In some embodiments, the circuit **106** may be capable of returning only a signal to indicate that the circuitry **106** and the corrosion sensor **100** is functioning properly. In other embodiments, the circuit **106** may return an identification number that may be unique to the sensor **100** being read. In further embodiments, the circuit **106** may contain an electrically erasable programmable read-only memory (EEPROM) that may be capable of storing data as well.

As can be seen from FIG. 1, the sensor **100** may only be capable of returning a confirmation or identification signal while the corrosion sensitive connector **108** remains substantially intact. Because the corrosion sensitive connector **108** is exposed to the environment, it will be able to detect the cumulative effects of corrosive forces within the environ-

ment. When the corrosion sensitive connector **108** becomes substantially corroded such that it is no longer conductive, the sensor **100** will fail to respond to interrogation. It can be seen that without the corrosion sensitive connector **108** being substantially intact, the sensor **100** will be unable to return a signal because the circuit **106** no longer has a means of being powered nor a way to transmit a confirmation signal or identification number back. When the corrosion sensitive connector **108** is substantially corroded, the antenna **104** is essentially insulated from the circuit **106**.

Referring now to FIG. *2a*, a close up cutaway view of the antenna **104** and corrosion sensitive connector **108** is shown. As can be seen here, the corrosion sensitive connector **108** is required for continuity between the antenna **104** and the circuit **106**. The drawing of FIG. *2a* illustrates the corrosion sensitive connector **108** in a substantially intact configuration. That is, the corrosion sensitive connector **108** is largely corrosion free. Referring now to FIG. *2b*, the corrosion sensitive connector **108** is illustrated in a substantially corroded state. It can be seen here that the corrosion sensitive connector **108**, due to its exposure to the corrosive environment, has corroded to the point that continuity no longer exists between the antenna **104** and the circuit **106**.

The material comprising the corrosion sensitive connector **108** may be chosen according to the underlying material of the test object. For example, if a sensor is employed to detect corrosion within a pipeline, the corrosion sensitive connector **108** should be made of a material substantially similar to that of the pipeline. In one embodiment, the sensor **100** could be applied to such a pipeline in between the primer and paint layers. It will be appreciated that the corrosion sensors **100** can be utilized to detect corrosion within and throughout a number of other structures.

Monitoring corrosion can help ensure structural integrity, reduce the risk of fatigue failures, and provide non destructive engineering test data, among other uses. By way of example and not by limitation, applications for the wireless passive corrosion sensors **100** include highways and bridges, pipelines, waterways and ports, hazardous materials storage, airports and aircraft, and railroads. The corrosion sensor **100** may be placed in any location where corrosion is a concern. In this way, corrosion may be detected before it becomes problematic and without substantial dismantling of the structure being monitored.

In addition to choosing a specific material for the corrosion sensitive connector **108** that is reflective of the corrosion sensitivity of the test object, the thickness of the material may also be chosen to reflect the degree of corrosion that is noteworthy with regards to the test object. The corrosion sensitive connector **108** may be varied in thickness to account for the degree of corrosion on the test object at which the sensor **100** should detect corrosion. In the present embodiment, the sensor **100** is binary. That is, the sensor **100** will be reflective only of whether or not corrosion has occurred and not necessarily the degree of corrosion. Hence, the thickness of the corrosion sensitive connector **108** may be utilized to ensure that corrosion is detected at the point desired by the end user.

In some embodiments the corrosion sensitive connector **108** will range from about 0.5 μm up to about 1 mm. Some thicknesses of the corrosion sensitive connector may be constructed from thin wire or foil comprised of the appropriate material. In other embodiments, the corrosion sensitive connector may be deposited into place using techniques such as chemical vapor deposition or other deposition techniques. Some embodiments will provide a corrosion sensitive connector **108** of the thinnest degree possible that is able to

maintain circuit continuity. In these embodiments, the slightest degree of corrosion will register using the sensor **100**.

It will be appreciated that the RFID tags of the present disclosure could be based in part on commercially available RFID tags. Many off the shelf RFID tags encase the antenna and other circuitry in a protective covering. In FIG. *1*, this corresponds to the cover **102**. The covering could be plastic, polymer or any other suitably resilient material. In one embodiment, the sensor **100** could be constructed by mechanically removing or opening a portion of the cover and a portion of the antenna link material and replacing it with the corrosion sensitive connector **108**. Acid etching of the cover to provide access to modify the internal components is also a possibility. In one embodiment, the sensor **100** will be constructed from a Tag-it™ HF Transponder Inlay Rectangle—Large, Part Number RI-I02-110A, available from Texas Instruments Incorporated of Dallas, Tex.

Referring now to FIG. *3*, another embodiment of a wireless corrosion sensor is illustrated. In the embodiment of FIG. *3*, the corrosion sensor **300** is designed to remain non-operative until corrosion has been detected. As before, a cover **102** is provided, as well as an antenna **104**, a circuit **106** and a corrosion sensitive connector **108**. In the embodiment of FIG. *3*, however, it can be seen that the corrosion sensitive connector **108** has been placed in a position to short the antenna **104**. In this way, regardless of whether or not the antenna **104** is energized from an outside source, it will not be capable of transmitting the energy into the circuit **106**. Upon corrosion of the corrosion sensitive connector **108**, the corrosion sensitive connector **108** will no longer be able to short the antenna **104**. At this time, the sensor **300** will operate as was previously described. Thus, only after corrosion of the corrosion sensitive connector **108** has occurred will the sensor **300** be active. As described, the sensor **300**, when active, may be able to transmit a confirmation signal which may include an identification number and possibly other data. The other data may include, for example, the date that the sensor **300** was installed, the precise location of the sensor, the composition of the corrosion sensitive connector **108**, and/or other pertinent information.

Referring now to FIG. *4*, a schematic diagram of the corrosion sensor **100** in a configuration to detect galvanic corrosion is illustrated. In FIG. *4*, the cover **102** is shown in partial cutaway. It can be appreciated from FIG. *4* that the cover **102** covers substantially all of sensor **100** except for the corrosion sensitive connector **108**. In the embodiment of FIG. *4*, the corrosion sensitive connector **108** is further provided with a conduction lead **402**. The conduction lead **402** may be comprised of steel, zinc, or other metals or alloys thereof. The conduction lead **402** may connect to a test object **404**. In this way, the sensor **100** may be better equipped to detect galvanic corrosion as is known to occur in certain applications. The test object **404** could be a portion of a ship, an aircraft, a tank, a pipeline, or any number of test objects for which corrosion monitoring is desired.

Referring now to FIG. *5*, one embodiment of a system for monitoring corrosion using wireless passive corrosion sensors according to the present disclosure is shown. In the present embodiment, the system **500** comprises a scanner **502**, together with a number of corrosion sensors **100**. It will be appreciated that although only a single sensor **100** is shown, a typical system would have a number of sensors **100**. Furthermore, the sensors could be in any configuration, including the sensor **100** as shown. The sensors could also be configured as in FIG. *3* or as in FIG. *4*.

The reader or scanner **502** will transmit microwave, magnetic, or radiofrequency energy **510** to the sensor **100**. The

reader **502** may be a handheld reader or could be stationary and capable of reading multiple sensors **100** simultaneously. Some embodiments of the system **500** will be based upon load modulation or reflected power/backscatter technology. One commercially available device that may be utilized as the scanner **502** in certain embodiments is the Texas Instruments RFID Systems S4100 Multi-Function Reader available from Texas Instruments Incorporated of Dallas, Tex.

There may be a separate transmission of an interrogator signal **510** from the scanner **502** and a separate response signal **512** from the sensor **100**. In some embodiments, both the scanner **502** and the corrosion sensor **100** will have a single antenna that is used for both transmission and reception. The scanner **502** and sensor **100** may operate in accordance with known standards, such as the ISO/IEC 18000 RFID Air Interface Standard. Other embodiments may operate according to other standards or according to a custom-designed interface.

Passive RFID tags or sensors of the present disclosure that operate at frequencies below 100 MHz are typically powered by magnetic induction. An alternating current in a scanner **502** coil induces a current in the sensor **100** antenna coil **104**. This allows charge to be stored in a capacitor that may then be used to power the electronics of the sensor **100**. When the sensor **100** has been powered, the information contained within the sensor **100** may be sent back to the scanner **502** by a process called load modulation. In load modulation, the loading of the sensor's coil is changed in a pattern over time that affects the current being drawn by the scanner coil. In order to recover the information or identity transmitted by the sensor **100**, the scanner **502** decodes the change in current as a varying potential developed across a series of internal resistors (not shown).

Because the sensors **100** may be located some distance from the scanner **502**, possibly buried with the pipeline or imbedded in the structure of the test object, data coupling between the scanner **502** and the sensor **100** may only occur where the magnetic field between the scanner **502** and the sensor **100** is strong enough to allow. This communication region may be known as the near field region. Beyond the near field region, the far field region is where energy from the scanner **502** begins to propagate as radio waves.

The boundary of the near field and far field is governed by the frequency of the alternating current used to energize the coils of the scanner **502**. The boundary is approximately limited to a distance of $C/2\pi f$, where C equals the speed of light and f equals the frequency. In one embodiment, 13.56 MHz sensors will be used which will limit interaction distance to approximately a maximum of 11.7 feet. The magnetic field strength between the scanner **502** and the sensor **100** falls off in proportion to $1/D^3$, where D is the distance from the scanner **502** to the sensor **100**. Depending upon the location of the sensor **100** and/or the test object, larger scanners **502** and/or sensors **100** could be utilized to increase the effective communication distance.

Higher frequency systems have a relatively short range in the near field and therefore a different capture principal may be utilized. An electromagnetic capture method may be used to read sensors **100** operating at frequencies above about 100 MHz. This technique involves the use of electromagnetic waves propagating from the scanner **502** to power the sensor **100** in the far field region. Using this technique, data cannot be sent back to the reader using load modulation because the sensor **100** is operating beyond the near field. In such an embodiment, radio frequency backscatter may be used.

The sensor **100** electronics may alter the impedance of the antenna **104** and thereby reflect back some of the incident RF

energy to the scanner **502**. In this embodiment, the scanner **502** uses a sensitive receiver to attain the identification or other information from the sensor **100** utilizing the pattern of reflections that is coded as variation in the amplitude of the received signal **512**. In this embodiment, the energy delivered to the sensor **100** from the scanner **502** will follow an inverse square law. The return signal **510** will also follow an inverse square law. Thus, the transmit power is attenuated by a $1/D^4$ law. Although this is a very rapid decline in signal strength over distance, the system **500** may work over a distance of about 3 to 4 meters, or in some cases even further.

Theoretically, the sensors **100** can operate on virtually any frequency, but in practice they may be limited by varying regulations to one of a number of specified bands. The band utilized may be selected based upon the end use of the sensor **100**. Between about 100 and 500 kHz, the signal will have good penetrative properties for buildings and may also work around conductive barriers such as liquids and other materials. However, a low reading speed may be limiting at this frequency. The frequency band between about 10 and 15 MHz has a medium reading speed, but may not be able to penetrate sufficiently to reach the desired test object. Even higher frequencies than these may be utilized and may achieve long range reading capabilities when limited only by line of sight. However, the higher frequencies are more easily thwarted by obstructions such as walls, soil, water, etc. Moreover, the higher band frequencies may be prone to problems with reflection and interference.

In light of the various limitations with regard to the frequency bands, the low and high bands may be most useful for underground monitoring. However, the higher frequency bands may be useful for galvanic type sensors placed on above ground portions of a test object. In one embodiment, a frequency of about 126 kHz may be utilized. This frequency is virtually transparent to soil, concrete, paper, water, conductive liquids and slurries. The sensors **100** and scanner **502** may also have anti-collision circuitry and/or software such that multiple sensors **100** can be scanned simultaneously with a single scanner **502**.

The sensor **100** may be visible or may be covered or hidden within the structure or test object being monitored. In any event, the sensor **100** receives the wireless energy **510** and responds with the confirmation signal **512**. The confirmation signal **512** may be received and stored by the reader **502**. It can be appreciated that data from many sensors **100** may be read and stored within the reader **502**. As described, in some embodiments each sensor **100** may be able to respond with a unique ID number and possibly other information concerning the location, placement, or state of the sensor **100**.

In some embodiments the system **500** will also have a computer **504**. This computer could be a laptop, a personal computer, a server, a workstation, or a simply a data repository. The reader **502** may communicate with the computer **504** the information **514** obtained from scanning for the sensors **100**. In this manner, data may be correlated using the computer **504**. Data **514** could be communicated between the computer **504** and scanner **502** via wire or wirelessly according to known protocols. In some embodiments, a number of scanners **502** could be used, possibly by multiple persons, when scanning a very large object. The data could be correlated and condensed by the computer **504** such that a complete picture of the state of corrosion of the test object can be constructed.

Referring now to FIG. 6, one possible application of the corrosion sensors **100** on a test object **602** is shown. In the embodiment of FIG. 6, a test object **602** is an aircraft. As described, the test object **602** could be any number of struc-

tures or locations where corrosion is being monitored. Here, four sensors **100** are shown at various locations on the test object **602**. As has been described, these corrosion sensors **100** may be scanned and their locations recorded.

Referring now to FIG. 7, a graphical display of an object being monitored for corrosion is shown. A display **702** could be located on the hand-held scanner **502**, the computer **504**, or on another suitable location. A graphical representation or model **704** may be constructed based upon the test object **602**. In some embodiments, the model **704** may be three dimensional such that a user could visually determine the state of corrosion of the entire test object **602**. In FIG. 7, a point of corrosion **706** is illustrated graphically on the model **704**. This may correspond to corrosion detected by one of the corrosion sensors **100** shown in FIG. 6. In addition to the location of the corrosion **706**, the display **702** could also provide information obtained from the relevant corrosion sensor. As described, this may include the exact location of the corrosion sensor within the test object, as well as the date of installation of the corrosion sensor and other pertinent information. It can be that the corrosion sensors and monitoring described herein provide a relatively quick way to scan a test object **602** for corrosion without dismantling the test object **602**. In some cases, the test object **602** may be immediately decommissioned based upon the readings obtained from the corrosion sensors. In other embodiments, all or a portion of the test object **602** could be flagged for further corrosion or structural testing.

Referring now to FIG. 8, another embodiment of a wireless corrosion sensor according to aspects of the present disclosure is shown. The sensor **800** is similar in some aspects to the sensors previously described, such as the sensor **100** of FIG. 1. The sensor **800** has a covering shown here with the top half removed to illustrate the internals of the sensor **800**. An antenna **104** is provided which, once again, is utilized by the sensor **800** to receive power or an interrogation signal as well as provide any return signal.

The sensor **800** provides a microchip **802** that may be connected to a number of corrosion sensitive connectors. In the present embodiment, three such connectors are illustrated: **804a**, **804b**, and **804c**. The chip **802** may be a custom made complimentary metal oxide semiconductor (CMOS) chip or another chip that is capable of performing the requisite functionality, as will be described herein. The overall design of the sensor **800** is such that varying degrees of corrosion may be detected by the sensor **800**. This may be accomplished in a number of way, such as by each of the corrosion sensitive connectors **804a**, **804b**, **804c** having a different thickness. In another embodiment, each of the connectors **804a**, **804b**, **804c** may be comprised of a slightly different material. Making the connectors **804a**, **804b**, **804c** of different material may also allow for the detection of different types of corrosion. Corrosion by the presence of multiple different chemicals of corrosive agents could be tested utilizing the sensor **800**.

When the sensor **800** is energized or activated by a scanner, the chip **802** may provide a test current into each of the corrosion sensitive connectors **804a**, **804b**, **804c**. It can be seen that the corrosion sensitive connectors **804a**, **804b**, **804c** are arranged in parallel in the present embodiment (though they may share a power lead). The chip **802** determines whether the circuit is completed through each of the corrosion sensitive connectors **804a**, **804b**, **804c** (or has a substantial degree of continuity therethrough). The chip **802** may then encode the results of the test of the corrosion sensitive connectors **804a**, **804b**, **804c** and transmit the results on the antenna **104**.

In one embodiment, the corrosion sensitive connectors **804a**, **804b**, **804c** will be connected to an input/output I/O port on the chip **802**. A positive voltage can be applied to each of the corrosion sensitive connectors **804a**, **804b**, **804c** and the voltage on the connectors read by the I/O port. In one logic mode, the port would read a '1' for each intact connector. In the present embodiment with three corrosion sensitive connectors **804a**, **804b**, **804c** if the connectors are attached to the least significant bits of a four bit port, and each is intact, the result read into the chip **802** would be '0111'. If the first sensor was substantially corroded the input would become '0110', and if the first two connectors were corroded the input would become '0100'. It can be appreciated that other schemes are possible including attaching many more connectors on the same chip **802** and sensor **800**.

In FIG. 8, the capacitor **806** that may be needed to store power to operate the CMOS chip **802** is shown in one of many possible locations. It is also understood that in other embodiments, the capacitor **806** could be an integral part of the antenna **104**, the chip **802**, or otherwise located elsewhere on the sensor **800**. It is also understood that in a production version of the sensor **800**, the cover **102** will cover substantially all of the components of the sensor **800**. The corrosion sensitive connectors **804a**, **804b**, and **804c** may be exposed to the ambient environment to detect corrosion.

Utilizing a sensor **800** as shown in FIG. 8, or possibly a plurality of sensors as previously described (each with a different corrosion sensitive connector material or thickness) degrees of corrosion may be effectively monitored. The composition and/or size of the corrosion sensitive connectors may be configured such that the sensor is activated at a number of different levels of corrosion. For example, trigger points could be set to activate when corrosion has occurred but is not serious, when corrosion is extensive, and when corrosion is severe. It may be useful to know when corrosion has occurred but is not serious for planning purposes or for testing purposes. Knowing that extensive corrosion has occurred may require scheduled repair and/or visual inspection. Severe corrosion may require immediate repairs and possibly abstaining from use of the monitored structure until inspection and/or repair can occur.

Thus, the present invention is well adapted to carry out the objectives and attain the ends and advantages mentioned above as well as those inherent therein. While presently preferred embodiments have been described for purposes of this disclosure, numerous changes and modifications will be apparent to those of ordinary skill in the art. Such changes and modifications are encompassed within the spirit of this invention as defined by the claims.

What is claimed is:

1. An apparatus for monitoring a degree of corrosion comprising:
 - an antenna that receives an interrogation signal;
 - an integrated circuit powered by the interrogation signal from the antenna; and
 - a plurality of corrosion sensitive connectors connected to the integrated circuit;
- wherein the integrated circuit in response to the interrogation signal provides a continuity test of each of the plurality of corrosion sensitive connectors and provides a response back through the antenna indicative of the continuity test results.
2. The apparatus of claim 1, wherein the plurality of corrosion sensitive connectors has corrosion sensitive connectors of at least two thicknesses.

9

3. The apparatus of claim 1, further comprising a capacitor for storing energy from the interrogation signal for use by the integrated circuit.

4. The apparatus of claim 1, wherein each of the plurality of corrosion sensitive connectors are connected to the integrated circuit in parallel.

5. An apparatus for monitoring a degree of corrosion comprising:

an antenna that receives an interrogation signal;

a digital circuit powered by the interrogation signal from the antenna; and

a plurality of corrosion sensitive connectors connected to the integrated circuit;

wherein the digital circuit in response to the interrogation signal provides a continuity test of each of the plurality of corrosion sensitive connectors and provides a digital response back through the antenna indicative of the continuity test results.

6. The apparatus of claim 5, wherein the digital circuit provides an identifier along with the continuity test results.

7. A method of modeling corrosion of a test object, the method comprising providing one or more wireless corrosion sensors, the each sensor comprising:

10

a integrated circuit (IC) chip configured to provide a signal response when energized; and

an antenna configured to wirelessly receive energy for energizing the circuit and to receive the signal response from the circuit and transmit the signal response; and

a plurality of corrosion sensitive connectors electrically connected to the IC chip to allow for continuity testing of each of the plurality of corrosion sensitive connectors;

applying the plurality of corrosion sensors to the test object in locations where corrosion is monitored;

wirelessly energizing the plurality of wireless corrosion sensors; and

receiving a plurality of signal responses from the plurality of wireless corrosion sensors, the signal responses including results of continuity tests and an identifier from each of the corrosion sensors.

8. The method of claim 7, further comprising rendering a graphical depiction of a state of corrosion of the test object based upon the plurality of signal responses received from the plurality of wireless corrosion sensors.

* * * * *